INTRODUCTION

Thank you very much for your purchase of the SHARP Electronic Cash Register, Model ER-A460/A470. Please read this Manual carefully before operating your machine in order to gain full understanding of functions and features.

Please keep this manual for future reference, it will help you, if you encounter any operational problems.

IMPORTANT

- **Install your cash register in a location that is not subject to direct radiation, unusual temperature changes, high humidity or exposed to water sources.**
Installation in such locations could cause damage to the cabinet and the electrical components.
- **The register should not be operated by an individual with wet hands.**
The water could seep into the interior of the register and cause component failure.
- **When cleaning your register, use a dry, soft cloth. Never use solvents, such as benzine and/or thinner.**
The use of such chemicals will lead to discoloration or deterioration of the cabinet.
- **The register plugs into any standard wall outlet (official (nominal) voltage).**
Other electrical devices on the same electrical circuit could cause the register to malfunction.
- If the register malfunctions, call your local dealer for service - do not try to repair the register yourself.

PRECAUTION

This Electronic Cash Register has a built-in memory protection circuit which is operated by rechargeable batteries.

As you know, all batteries will, in time, dissipate their charge even if not used. Therefore to insure an adequate initial charge in the protection circuit, and to prevent any possible loss of memory upon installation, it is recommended that each unit be allowed to recharge for a period of 24 to 48 hours prior to use by the customer. In order to charge the batteries, the machine must be plugged in and its power switch must be set to the "ON" position. This recharging precaution can prevent unnecessary initial service calls.

CONTENTS

INTRODUCTION.....	1
IMPORTANT	1
PRECAUTION.....	1
EXTERNAL VIEW OF THE ER-A460.....	6
Front view.....	6
Rear view.....	6
EXTERNAL VIEW OF THE ER-A470.....	7
Front view.....	7
Rear view.....	7
PRINTER.....	8
KEYBOARD.....	9
1 ER-A460 standard keyboard layout.....	9
2 ER-A470 standard keyboard layout.....	11
3 Standard key number layout.....	13
4 Inserting of the key sheet	13
KEYS AND SWITCHES.....	14
1 Mode switch and mode keys	14
2 Cashier keys	15
3 Receipt ON-OFF function	15
4 Drawer lock key	15
5 Printer cover lock key	15
DISPLAYS	16
1 Operator display	16
Dot matrix display	16
7-segment display	17
Machine state indicator lamps.....	17
2 Customer display (Pop-up type).....	17
<div style="border: 1px solid black; padding: 5px; margin: 10px 0;">FOR THE MANAGER</div>	
PRIOR TO PROGRAMMING.....	20
1 General instructions.....	20
2 How to program alphanumeric characters.....	23
By using character keys on the keyboard.....	23
By entering character codes.....	24
By using character keys on the programming remote keyboard	24
PROGRAMMING	26
Preparations for programming.....	26
1 Setting the date and time.....	26
Setting the date (#2610).....	26
Setting the time (#2611)	27
2 Setting the register and consecutive numbers	27
Setting the register number (#2612).....	27
Setting the consecutive number (#2613).....	28
3 Programming the tax rate	28
Programming (#2711).....	28
4 Programming for departments.....	29
Functional programming (#2110)	29
Tax status (#2111).....	31
A limit amount (HALO) of entry (#2112).....	32
Alphanumeric characters (#2114)	33
Unit price (#1110).....	34

Commission group assignment (#2115).....	34
Group number (#2116).....	35
Key number assignments for departments (#2119)	36
5 Price lookup (PLU) programming	37
Department assignment (#1200, 2230)	38
Unit prices (#1210)	40
Base quantity (#1211)	40
Sign (+/-) and tax status (#2211, 2232).....	41
Alphanumeric characters (#2214)	43
Assigning of PLUs to commission groups (#2215, 2235).....	44
Set PLU (#2221).....	45
Link PLU (#2220).....	45
Programming of PLU levels and direct PLU keys (#2219)	46
PLU/subdepartment mode (#2210, 2231)	47
Stock quantity (#1222, 1220, 1221).....	48
6 Programming for miscellaneous keys.....	50
Programming the rate ($\%$, \boxed{EX} , commission rate) and the deduction (\ominus) (#1310).....	50
A limit amount (HALO) of entry (\ominus , \boxed{RA} , \boxed{PO}) (#2312).....	51
+/- sign ($\%$, \ominus) (#2311)	52
% item or % subtotal selection ($\%$) (#2315)	53
Percent rate limitation ($\%$) (#2313).....	53
\ominus item or \ominus subtotal selection (\ominus) (#2316).....	54
7 Programming for the \boxed{TL} , $\boxed{CA2}$, \boxed{CH} through $\boxed{CH4}$, and $\boxed{CRI1}$ through $\boxed{CRA4}$ keys	55
Functional programming (#2320)	55
High amount lockout (HALO) for cheque cashing, cash in drawer and cheque change (#2321).....	57
High amount lockout (HALO) of entry for media keys (#2322).....	57
8 Programming of function text.....	58
Programming (#2314).....	58
List of function texts	59
9 Cashier programming	61
Cashier code (#1500).....	61
Cashier name (#1514).....	62
Functional programming to cashiers (#2510).....	63
10 Programming various functions	64
Programming for optional feature selection (#2616)	64
Programming alarm length of time with drawer opening (#2617).....	67
Programming the limit on the number of times of validation printing and the number of feed lines after printing of a difference subtotal (#2615).....	68
Programming of logo text (#2614).....	69
Programming of guidance messages (#2644).....	71
Programming of error messages (#2641).....	74
Selection of X1/Z1 and X2/Z2 reports to be printed in the stacked report sequence (#2620).....	76
Secret codes to control access to PGM1 mode, X1/Z1 mode and X2/Z2 mode (#2630, 2631, 2632)....	77
Setting the time range for hourly report (#2619).....	78
Programming of AUTO keys (#2900)	79
11 TRAINING mode	80
12 Reading stored programs	81
Program details and procedures for their reading	81
Sample printouts.....	82

READING (X) AND RESETTING (Z) OF SALES TOTALS.....	90
1 Summary of reading (X) and resetting (Z) reports and the key operations to obtain the reports	90
2 Daily sales totals.....	92
Full reading and resetting of sales totals	92
Cashier reading and resetting	95
Reading and resetting of hourly sales information	97

Full department reading	98
Individual group reading	98
Full group reading	98
Reading and resetting of sales information for a range of PLUs/subdepartments	99
Reading of sales information on PLUs/subdepartments associated with an individual department	100
Reading of sales information on PLUs/subdepartments whose sales amounts are zeros	100
Reading of sales information for the price amount range of PLUs/subdepartments	101
PLU stock information	101
Commission sales information	101
Transaction reading	102
Total in drawer reading	102
Reading and resetting of a stacked report	102
3 Periodic consolidation	103
General information	103
Reading and resetting of the daily net totals	104
Reading and resetting of a stacked report	104
COMPULSORY CASH/CHEQUE DECLARATION	105
OVERRIDE ENTRIES	107
CORRECTION AFTER FINALIZING A TRANSACTION (AFTER GENERATING A RECEIPT)	108
TIME DISPLAY AND AUTOMATIC UPDATING OF THE DATE	109
1 Time display	109
2 Automatic updating of the date	109

FOR THE OPERATOR

PRIOR TO ENTRIES	112
1 Preparations for entries	112
2 Error warning	112
ENTRIES	113
1 Item entries	113
Single item entries	113
Repeat entries	115
Multiplication entries	116
Successive multiplication entries	117
Split-pricing entries	118
Single item cash sale (SICS)/single item finalize (SIF) entries	119
2 Special entries for PLUs	120
PLU level shift (for direct PLU)	120
Set PLU entries	122
Link PLU entries	122
3 Displaying and printing subtotals	123
Normal subtotal	123
Difference subtotal (Differ ST)	123
4 Finalization of transaction	124
Cash or cheque tendering	124
Mixed tendering (cheque + cash)	124
Cash or cheque sale that does not need any tender entry	125
Credit sale	125
Mixed-tender sale (cash or cheque tendering + credit tendering)	126
5 Computation of VAT(Value Added Tax)/tax	127
VAT/tax system	127
VAT shift entries	128
6 Auxiliary entries	129
Percent calculations (premium or discount)	129
Deduction entries	130
Refund entries	131

Printing of non-add code numbers	131
7 Payment treatment	132
Currency exchange	132
Received on account entries	133
Paid out entries.....	133
No sale (exchange)	134
Cashing a cheque.....	134
8 Automatic sequencing key (AUTO key) entries.....	135
CORRECTION	136
1 Correction of the last entry (direct void).....	136
2 Correction of the next-to-last or earlier entries (indirect void).....	137
3 Subtotal void.....	138
4 Correction of incorrect entries not handled by the direct or indirect void function	138
SPECIAL PRINTING FUNCTIONS	139
1 Copy receipt printing.....	139
2 Guest check copy	140
3 Validation printing function	141
Validation slip setting and printing	141
Validation printing examples.....	141
Validation slip specifications.....	144
4 Printing of the employee arrival and departure times	145
OVERLAPPED CASHIER ENTRY	146
OPERATOR MAINTENANCE	147
1 In case of power failure	147
2 In case of printer's motor locking	147
3 Paper roll near-end sensing function (only for journal paper) <option>.....	148
4 Installing and removing the paper roll.....	148
Installing the paper roll	149
Removing the paper roll	150
Removing a paper jam	151
Recording paper specifications	151
5 Installing the ink ribbon cassette	152
6 Ink refill	153
7 Removing the till and the drawer	154
8 Opening the drawer by hand	154
9 Before calling for service	155
10 Resetting your cash register.....	155
LIST OF OPTIONS	156
SPECIFICATIONS	157
PROGRAMMING REMOTE KEYBOARD (OPTION) MODEL ER-01RK	158
1 External view	158
2 Precautions.....	159
3 Installing AAA batteries	159
4 Programming	160

EXTERNAL VIEW OF THE ER-A460

■ Front view

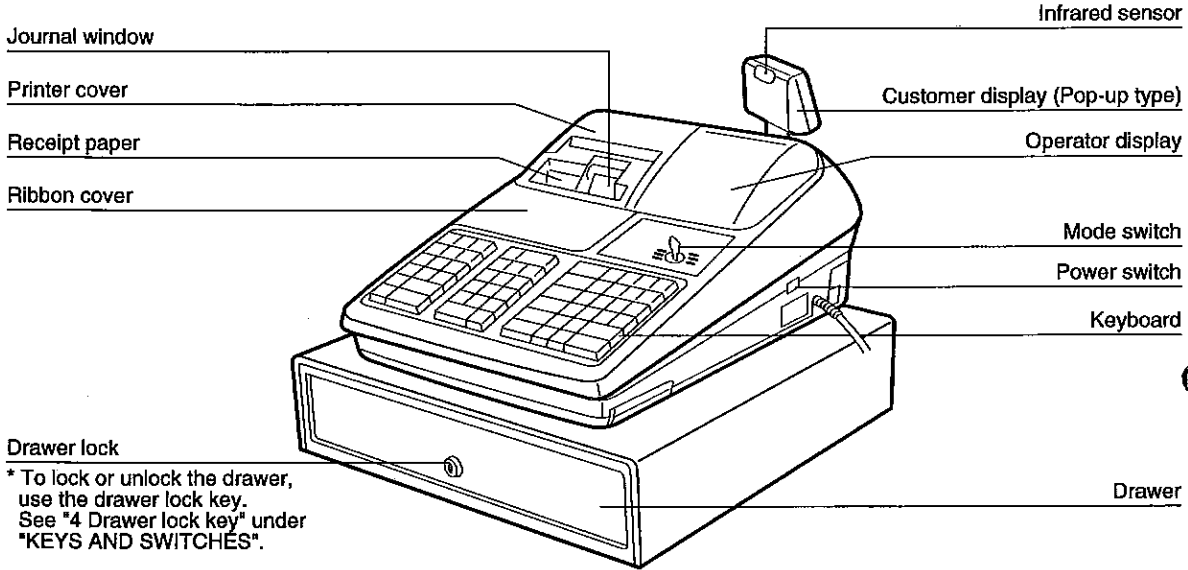

■ Rear view

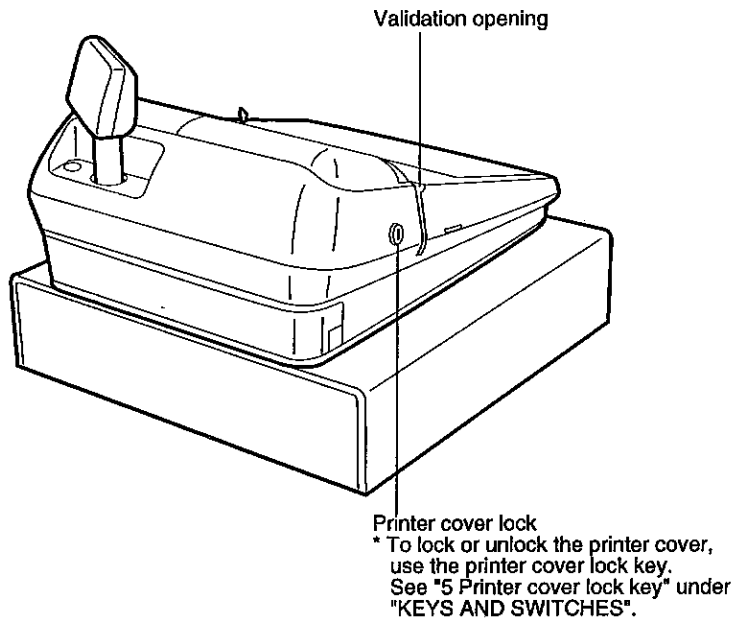

EXTERNAL VIEW OF THE ER-A470

■ Front view

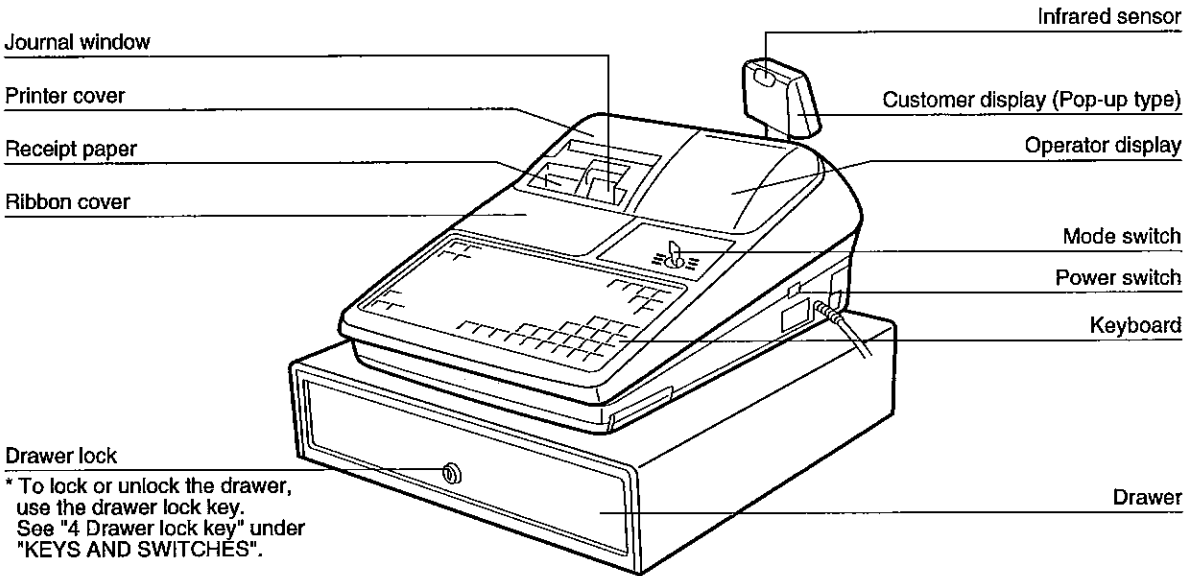

■ Rear view

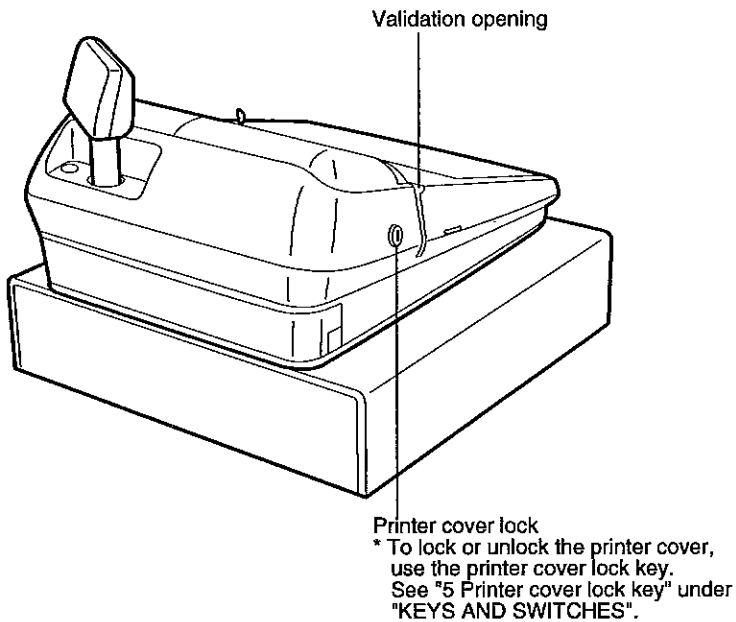

PRINTER

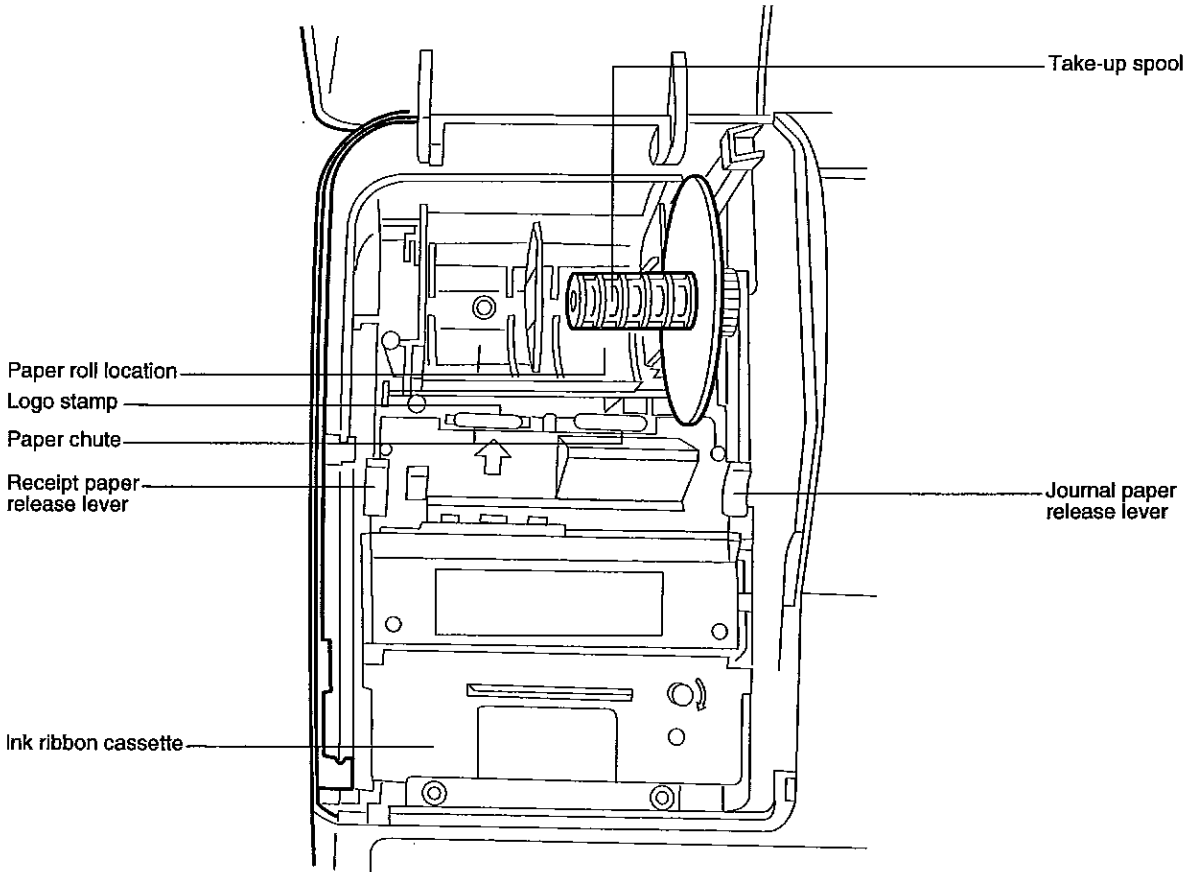

- **Paper release lever**

Used to load or unload the machine with paper roll (receipt and journal paper). Keep the lever down to take in or out the paper roll.

Note

Do not attempt to take in or out the paper roll without pressing this lever. This may result in damage to the printer.

KEYBOARD

1 ER-A460 standard keyboard layout

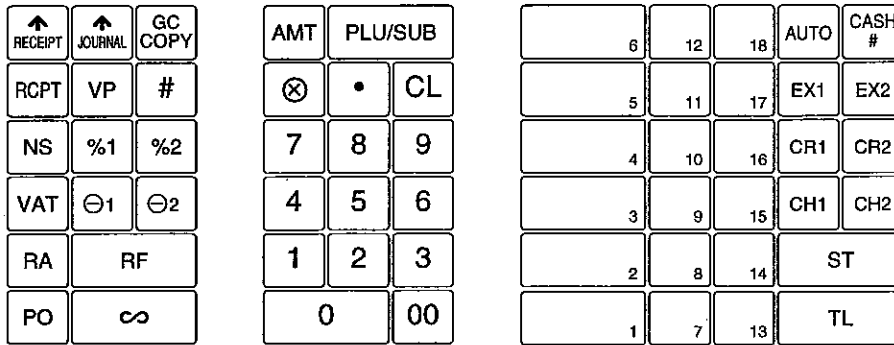

Note

All the keys except the receipt paper feed and journal paper feed keys can be re-positioned. If you want to change the layout, contact your dealer.

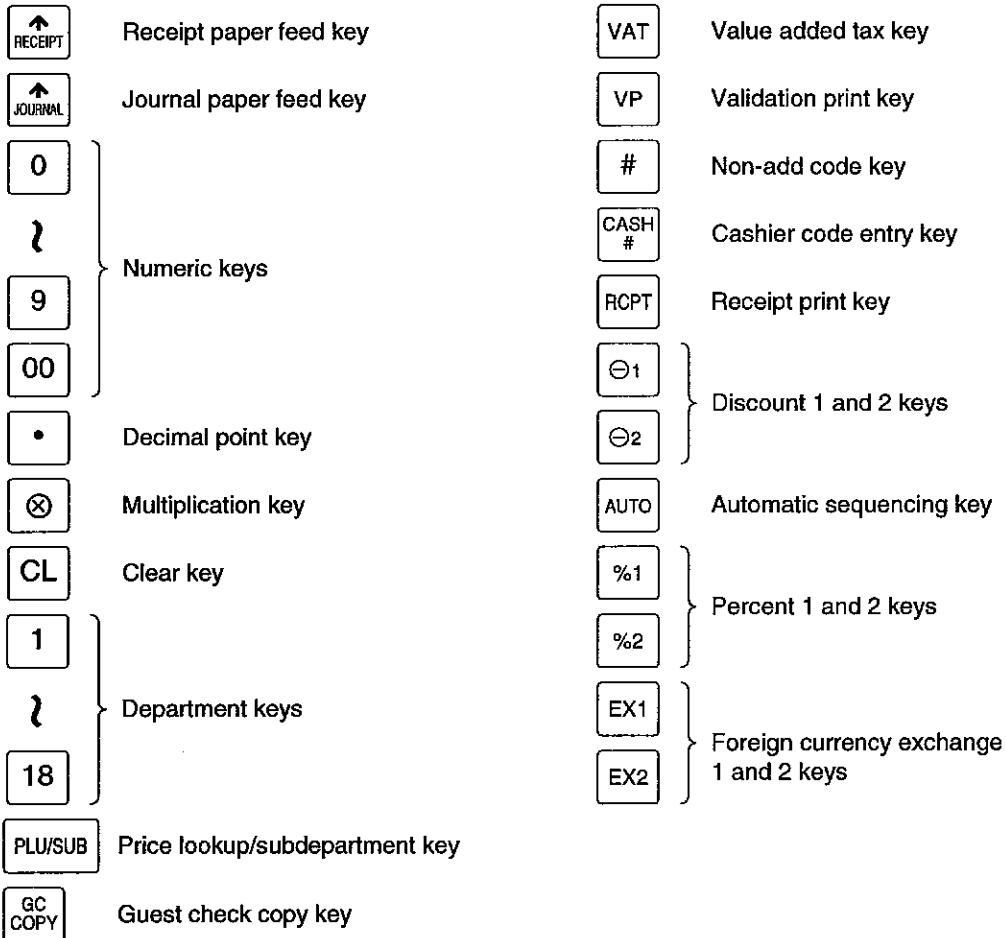

<input type="text" value="NS"/>	No-sale key	* <input type="text" value="VAT SHIFT"/>	Value added tax shift key	
<input type="text" value="RA"/>	Received-on-account key	* <input type="text" value="%3"/>	} Percent 3 and 4 keys	
<input type="text" value="PO"/>	Paid-out key	* <input type="text" value="%4"/>		
<input type="text" value="RF"/>	Refund key	* <input type="text" value="⊖3"/>	} Discount 3 and 4 keys	
<input type="text" value="∞"/>	Void key	* <input type="text" value="⊖4"/>		
<input type="text" value="CR1"/>	} Credit 1 and 2 keys	* <input type="text" value="AUTO 2"/>	} Automatic sequencing 2 through 5 keys	
<input type="text" value="CR2"/>		} <input text"="" type="text" value="CH1"/>		} Cheque 1 and 2 keys
<input type="text" value="CH2"/>				
<input type="text" value="AMT"/>	Amount key	* <input type="text" value="RA2"/>		Received-on-account 2 key
<input type="text" value="ST"/>	Subtotal key	* <input type="text" value="PO2"/>		Paid-out 2 key
<input type="text" value="TL"/>	Total (cash total) key	* <input type="text" value="CR3"/>	} Credit 3 and 4 keys	
* <input type="text" value="L1"/>	} PLU's level shift keys	* <input type="text" value="CR4"/>		
* <input type="text" value="L2"/>				
* <input type="text" value="L3"/>				
* <input type="text" value="19"/>	} Department keys	* <input type="text" value="CA2"/>	Cash total 2 key	
} <input text"="" type="text" value="50"/>				
* <input type="text" value="1"/>		} Direct price lookup/subdepartment keys	* <input type="text" value="EX3"/>	} Foreign currency exchange 3 and 4 keys
} <input text"="" type="text" value="82"/>				
		* <input type="text" value="CH3"/>	} Cheque 3 and 4 keys	
		* <input type="text" value="CH4"/>		
		* <input type="text" value="DIFFER ST"/>	Difference subtotal key	

Note































The standard keyboard is not equipped with those keys that are marked with (*).

2 ER-A470 standard keyboard layout

↑ RECEIPT	↑ JOURNAL	3	6	9	12	L3	8	16	24	32	40	48	56	64
RCPT	VP	2	5	8	11	L2	7	15	23	31	39	47	55	63
CASH #	VAT	1	4	7	10	L1	6	14	22	30	38	46	54	62
#	GC COPY	⊗	•	CL	AMT	CR2	5	13	21	29	37	45	53	61
⊖1	⊖2	7	8	9	PLU / SUB	CR1	4	12	20	28	36	44	52	60
%1	%2	4	5	6	AUTO	CH	3	11	19	27	35	43	51	59
PO	RA	1	2	3	NS	EX1	2	10	18	26	34	42	50	58
RF	∞	0	00	000	ST	TL	1	9	17	25	33	41	49	57

Note

All the keys except the receipt paper feed and journal paper feed keys can be re-positioned. If you want to change the layout, contact your dealer.

	Receipt paper feed key		Value added tax key	
	Journal paper feed key		No-sale key	
	} Numeric keys		Receipt print key	
			Validation print key	
		} Discount 1 and 2 keys		
				
			AUTOMATIC SEQUENCING KEY	
	Decimal point key	%1 key icon" data-bbox="515 643 558 670"/>	} Percent 1 and 2 keys	
	Multiplication key	%2 key icon" data-bbox="515 680 558 707"/>		
	Clear key		Received-on-account key	
	} Department keys		Paid-out key	
			Refund key	
			Void key	
	} Direct price lookup/subdepartment keys		Non-add code key	
			Guest check copy key	
			Foreign currency exchange 1 key	
	Cashier code entry key			

CR1	} Credit 1 and 2 keys	* ⊖3	} Discount 3 and 4 keys
CR2		* ⊖4	
CH	Cheque key	* AUTO 2	} Automatic sequencing 2 through 5 keys
AMT	Amount key	}	
ST	Subtotal key	* AUTO 5	
TL	Total (cash total) key	* RA2	Received-on-account 2 key
L1	} PLU's level shift keys	* PO2	Paid-out 2 key
L2		* CR3	} Credit 3 and 4 keys
L3		* CR4	
* 13	} Department keys	* CA2	Cash total 2 key
}		* EX2	} Foreign currency exchange 2 through 4 keys
* 50	}		
* CH2	} Cheque 2 through 4 keys	* EX4	
}		* DIFFER ST	Difference subtotal key
* CH4	} Price lookup/subdepartment key	* 65	} Direct price lookup/subdepartment keys
* PLU/SUB		}	
* VAT SHIFT	Value added tax shift key	* 118	
* %3	} Percent 3 and 4 keys		
* %4			

Note

The standard keyboard is not equipped with those keys that are marked with (*).

3 Standard key number layout

These key numbers are used for positioning of department keys and direct PLU keys. Refer to pages 36 and 46. This layout can be changed by your dealer.

For ER-A460

106	112	118		
105	111	117		
104	110	116		
103	109	115		
102	108	114		
101	107	113		

For ER-A470

		103	106	109	112		008	016	024	032	040	048	056	064
		102	105	108	111		007	015	023	031	039	047	055	063
		101	104	107	110		006	014	022	030	038	046	054	062
							005	013	021	029	037	045	053	061
							004	012	020	028	036	044	052	060
							003	011	019	027	035	043	051	059
							002	010	018	026	034	042	050	058
							001	009	017	025	033	041	049	057

4 Inserting of the key sheet

The ER-A470 packing carton contains three types of key sheets: the standard key sheet, the programming key sheet and the blank key sheet. Lift the key cover by holding its center and place the key sheet between the key cover and the top cabinet as illustrated below.

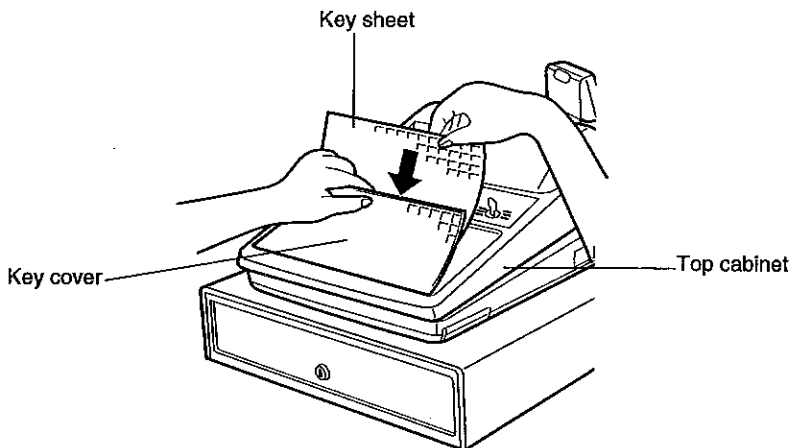

Note

- Do not spread the key cover too far as it might tear.
- Replace the key sheet with a new one if by chance it gets wet. Use of a wet key sheet may cause problems.
- Be sure to use only SHARP-supplied key sheets. Thick or hard sheets make key operation difficult.
- Smooth the key sheet evenly under the key cover, without any folds or wrinkles, to ensure easier operation.
- If you require a new key sheet, please consult your local dealer.
- Key cover will eventually wear out. If your key cover is dirty or broken, replace the cover with a new one. For details, consult your local dealer.

KEYS AND SWITCHES

1 Mode switch and mode keys

The mode switch can be operated by inserting one of the three supplied mode keys - manager (MA), submanager (SM), and operator (OP) keys. These keys can be inserted or removed only when the switch is in the "REG" or "⏻" position.

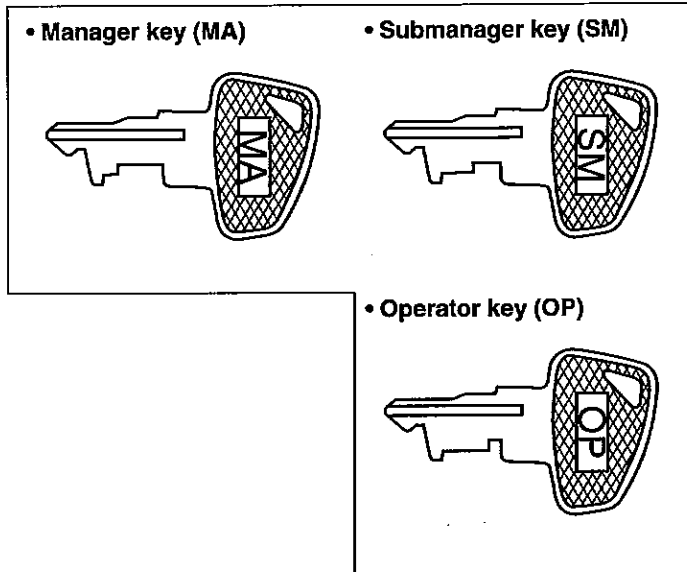
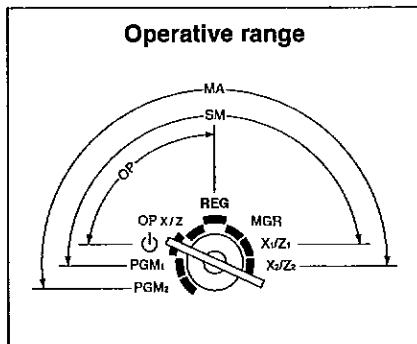

The mode switch has these settings:

- ⏻:** This mode locks all register operations. No change occurs to register data.
- OP X/Z:** This setting allows cashiers to take X or Z reports for their sales information. It can also be used for displaying the time and printing the employee arrival and departure times. And it can be used to toggle receipt state "ON" and "OFF" by pressing the **RCPT** key. (This setting may be used only when your register has been programmed for "OP X/Z mode available" in the PGM2 mode.)
- REG:** For entering sales
- PGM1:** To program those items that need to be changed often: e.g., unit prices of departments or PLUs, and percentages.
- PGM2:** To program all PGM1 programs and those items that do not require frequent changes: e.g., date, time, or a variety of register functions
- MGR:** For manager's and submanager's entries
The manager can use this mode to make entries that are not permitted to be made by cashiers - for example, after-transaction voiding and override entry.
- X1/Z1:** To take the X/Z report for various daily totals
- X2/Z2:** To take the X/Z report for various periodic (weekly or monthly) consolidation.

2 Cashier keys

This register allows the operator to use cashier keys in the following two ways:

- Cashier code entry system
- Real cashier key system

The standard machine has been shipped with the code entry system being programmed. If you want to change the cashier system, consult your dealer.

Cashier code entry system (Standard 4, max. 15)

The cashier codes are entered to identify cashiers.

Do the following procedure in advance:

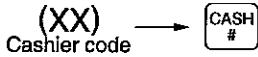

The register is ready to operate. It prints the cashier code.

Real cashier key system (max. 15)

The cashier keys serve to identify cashiers. Put one of the 1 through 15 keys in the cashier switch. The register prints the cashier code that corresponds to the inserted cashier key.

3 Receipt ON-OFF function

This function permits (when the function is in the ON status) or prohibits (when the function is in the OFF status) receipt printing in the REG mode. When the receipt ON-OFF function is in the OFF status, the "RCPT OFF" indicator lamp will light up.

Use the following procedure.

Procedure

1. Turn the mode switch to the OP X/Z position.
2. Press the  key to change the receipt printing status (ON or OFF).

Note *Your register will print reports regardless of the receipt state. This means that the receipt roll must be installed even when the receipt state is "OFF".*

4 Drawer lock key

This key locks and unlocks the drawer. To lock it, turn 90 degrees counterclockwise. To unlock it, turn 90 degrees clockwise.

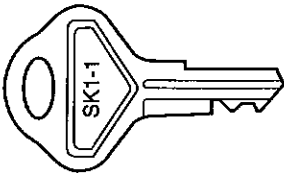

5 Printer cover lock key

This key locks and unlocks the printer cover. To lock it, turn 90 degrees counterclockwise. To unlock it, turn 90 degrees clockwise.

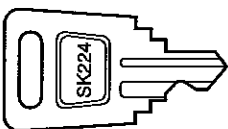

DISPLAYS

1 Operator display

The operator display consists of a 12-position dot matrix display (upper) and a 10-position 7-segment display (lower).

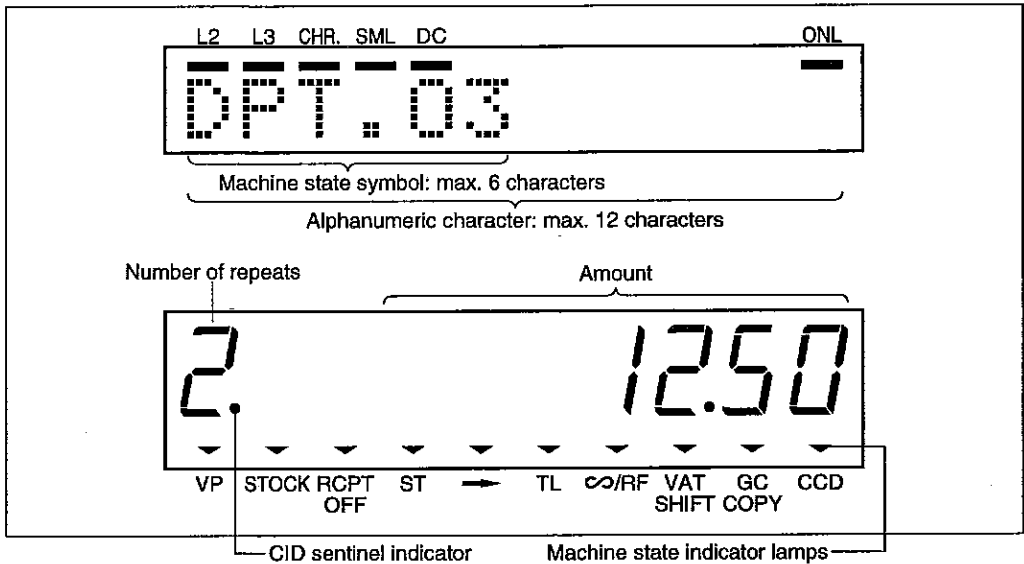

■ Dot matrix display

Alphanumeric characters: A text such as department code, PLU code, the text for each function or error message appears in the full 12 positions.

Machine mode caption: A machine mode caption appears in the left-most 6 (max.) positions.

Display	Machine mode
(No caption)	REG mode (In this mode, no caption appears.)
MGR.	Manager mode
VOID	Void mode
PGM1	PGM1 mode
PGM2	PGM2 mode
OP X/Z	OP X/Z mode
X1/Z1	X1/Z1 mode
X2/Z2	X2/Z2 mode

■ 7-segment display

Amount: An amount appears in the far right 7 (max.) positions.

Number of repeats for repetitive registrations:

The number of repeats is displayed from "2" and counted up with each repeat. When you have registered ten times, the display shows "0".

Example: (2→3→4.....9→0→1→2.....)

– **(Floating):** Appears when an entry into a minus department, minus PLU/subdept., or when a discount, refund or void entry is made.

■ Machine state indicator lamps

L2: Lights up when a second level PLU is selected.

L3: Lights up when a third level PLU is selected.

CHR.: Lights up when you are in the character entry mode.

SML: Lights up when only the lower-case letters are available for programming alphanumeric characters.

DC: Lights up when you are in the double-size character mode.

ONL: Lights up when the machine is connected to a device via an RS-232 for the online data communication.

VP: Lights up when the machine is programmed for compulsory validation printing.

STOCK: Blinks when the stock of the PLU which you entered is zero or negative.

RCPT OFF: Lights up when the receipt ON-OFF function signs OFF.

ST: Lights up when a subtotal is displayed.

→ : Lights up when the change due amount appears in the display or when the total sale amount is negative.

TL: Lights up when you finalize a transaction by pressing the **[TL]**, **[CA2]**, **[CH]** through **[CH4]** or **[CR1]** through **[CR4]** without any amount tendered entry.

∞/RF: Lights up when the **[∞]** key is pressed or when an item void entry is made. And lights up when the **[RF]** key is pressed or when a refund item entry is made.

VAT SHIFT: Lights up when the VAT status is shifted.

GC COPY: Lights up when the machine is in the GUEST CHECK COPY mode.

CCD: Lights up when the machine is programmed for compulsory cash/cheque declaration.

• : Appears right below the tenth place when the cash in drawer amount exceeds a programmed sentinel amount. The sentinel check is performed for the total cash in drawer.

(Sentinel lamp)

2 Customer display (Pop-up type)

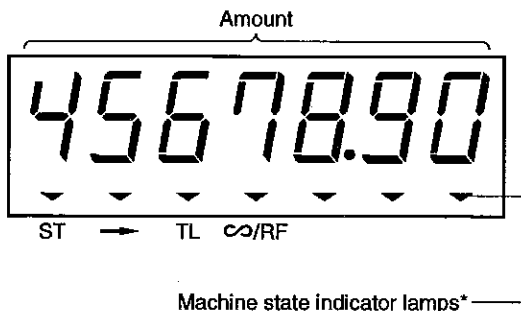

* These lamps light up in the same manner as the machine state indicator lamps in the operator display.

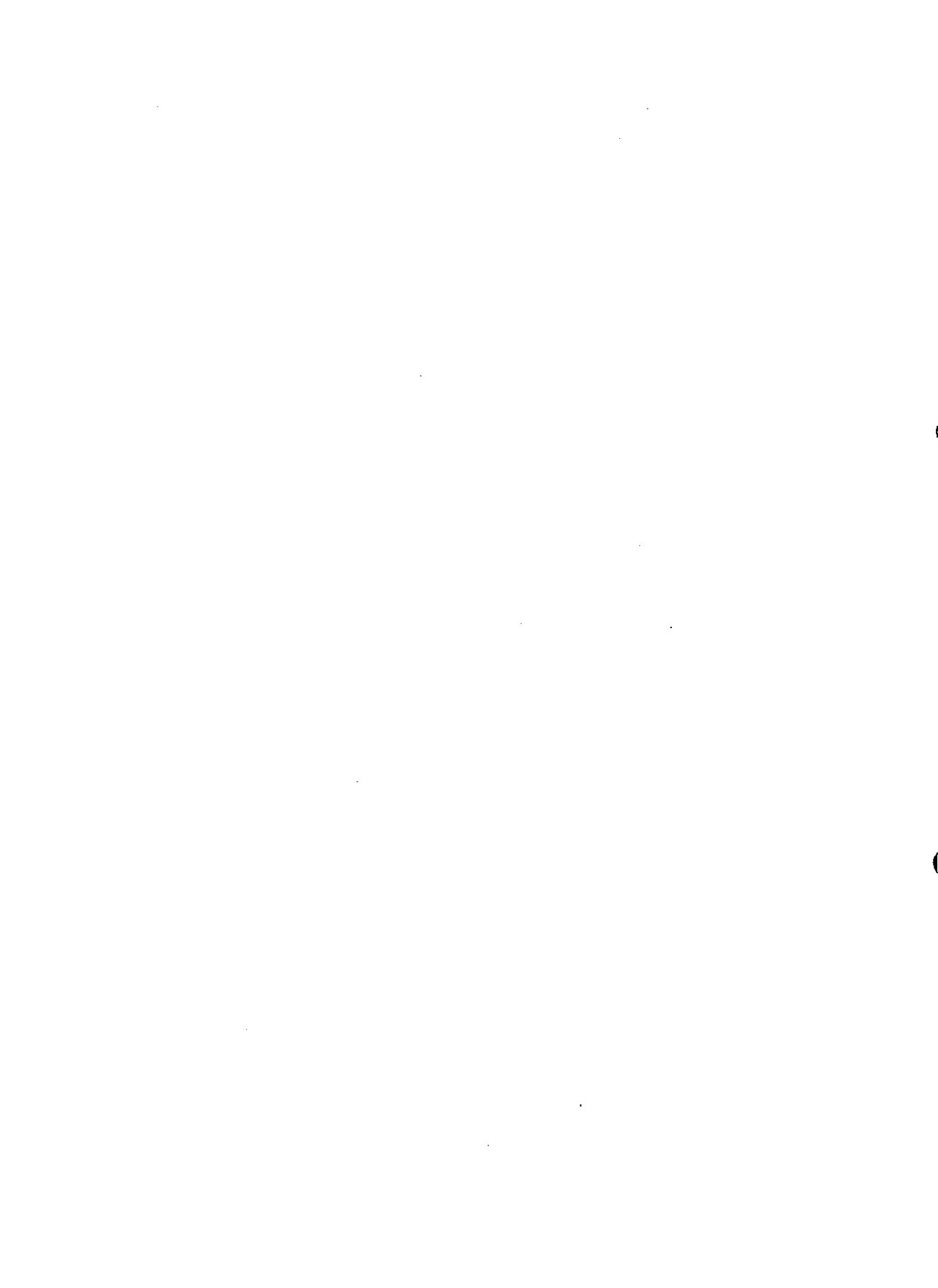

FOR THE MANAGER

PRIOR TO PROGRAMMING

1 General instructions

There are a few things you should keep in mind when programming your cash register. The following sections are considered general instructions because they apply to the majority of jobs and procedures contained in this manual. If you take a few minutes to read these, you might save yourself some time and aggravation when programming.

Note

Your machine allows you to program some items using a special "Easy programming" approach. Using "Easy programming", you can program values and parameters in each item, following the message displayed on the dot-matrix display. You need not enter job numbers and search function numbers for each key and for parameters. For the details of "Easy programming", see "Easy programming instruction manual".

Procedure

PGM1 or PGM2 mode

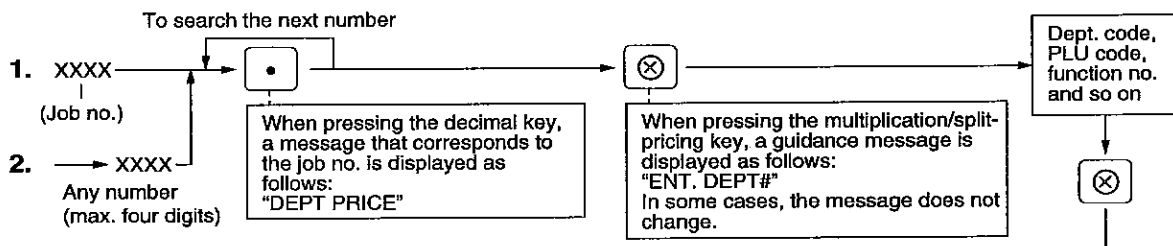

A

To change the current alphanumeric characters, do the following:

1. First press the **[00]** key to go into the character entry mode.
2. Enter alphanumeric characters. You can use character keys or character codes.

- By using character keys

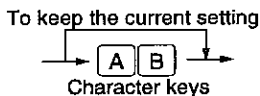

You can use also the **programming remote keyboard (ER-01RK)** for this method.

- By entering character codes

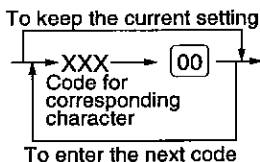

For the details of programming alphanumeric characters, see the next section, "2 How to program alphanumeric characters".

B

To change the current setting of prices, percentages, amounts and so on with numeric keys, do the following:



- * The number of digits depends on the programming item. See the appropriate section of the programming item.

When entering numerals, leading zeros are not required.

You can use also the **programming remote keyboard (ER-01RK)** for this method.

C

To change a value specified for the parameter, do the following:

A cursor will appear like this:

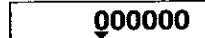

To keep the current number

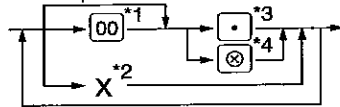

- *1 This key toggles between parameter values.
- *2 A corresponding numeric key
- *3 This key moves the cursor to the right.
- *4 This key moves the cursor to the left.
- *5 The number of parameters depends on the programming item.

If you specify unavailable numbers for any parameters, an error will occur. Pressing **[CL]** will clear the error and prompt you to enter a correct number. The cursor will show you the position you need to correct.

You can use also the **programming remote keyboard (ER-01RK)** for this method.

Entering numbers

When entering the job number or numbers as part of a procedure, use the numeric key. It contains the key and the key used in all procedure, there are two types of job number entering methods:

1. Entering a job number manually

This method is given by the procedure marked with "1." shown on the previous page. With this method, enter a job number you look up from an appropriate section in this manual, then press the key to change the current setting programmed for this job number.

2. Entering a job number automatically

This method is given by the procedure marked with "2." shown on the previous page. This method allows you to search the smallest one of job numbers, which your cash register has, by simply pressing the key. Or you can search the nearest number of a number you enter by pressing numeric keys and the key. A job number will be automatically displayed.

When you press the key, a message will appear with the job number. This message shows the purpose of the job. The displayed job number and message will be changed to the next number and message each time you press the key. For example, when the job number "1210" and the message "PLU PRICE" are displayed, press the key. The next job number "1211" and the message "PLU BASE QTY" will appear. If you want to search the previous job number, use the key. This key works in the opposite direction of using the key.

The following flow chart lists the job numbers and messages on the dot matrix display which show the type of the job number.

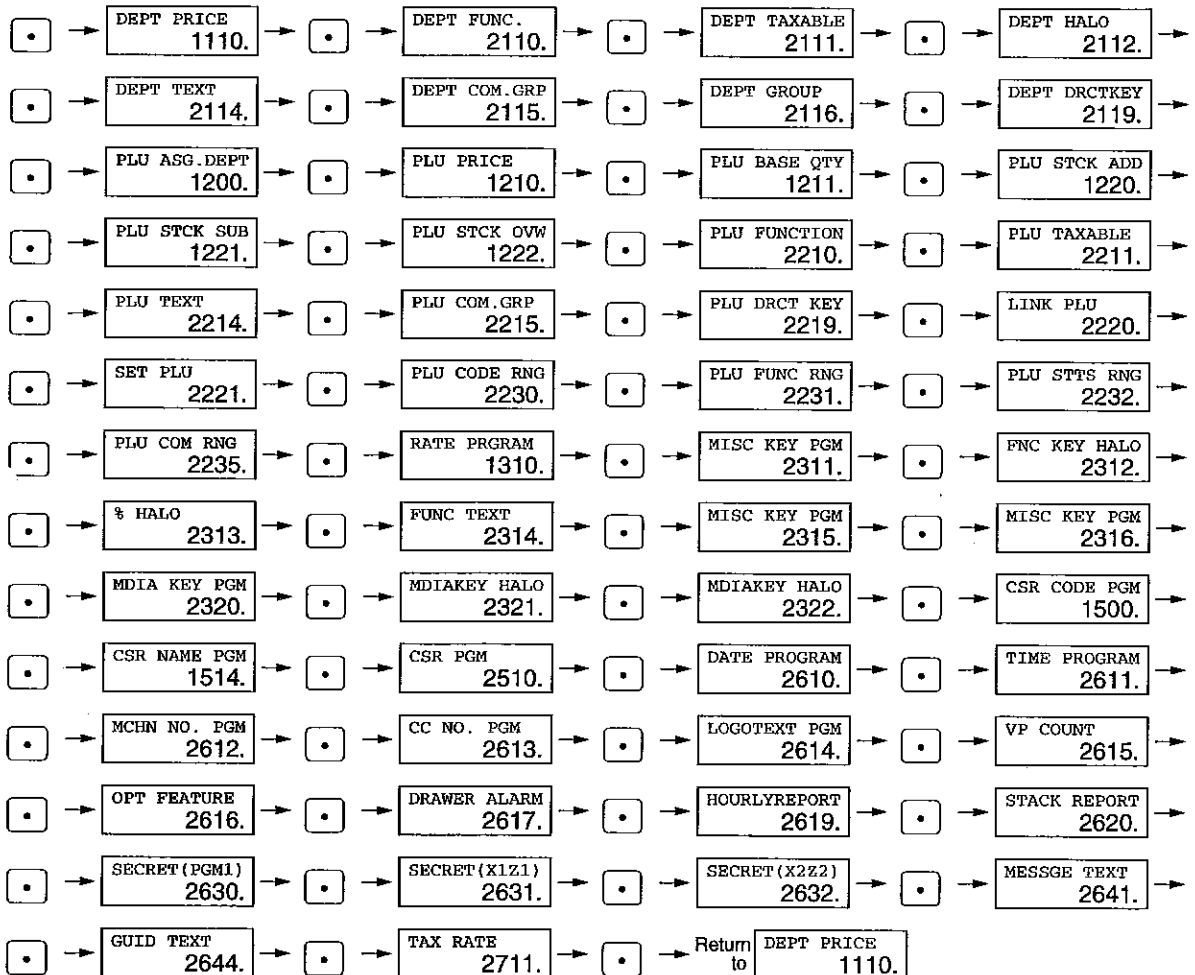

In PGM1 mode, only jobs numbered "1XXX" are available.

In this manual, programming procedures are for method "1. Entering job number manually".

To complete selecting a job number

To complete selecting a job number, press the **⊗** key. In some cases, the message changes to the new one. It prompts you to go to the next step.

To search a function number

To search a function number, press the **◻** key. This key shifts the function number each time you press the **◻** key. When you press the **◻** key with the last function number displayed, the first function number will be displayed.

If you want to search the previous function number, use the **◻◻** key. This key works in the opposite direction of using the **◻** key.

Entering options as part of a procedure

There are three types of methods for entering options.

A Entering alphanumeric characters

To enter alphanumeric characters, use character keys or character codes. See "A" in the procedure on page 20. For more information about entering alphanumeric characters, see the next section, "2 How to program alphanumeric characters".

B Entering numerals

To enter numerals, such as date, time, prices, percentages and so on, use the numeric keys. See "B" in the procedure on page 20.

C Entering parameters

To enter parameter numbers for each function, enter an appropriate number with a numeric key for each parameter. See "C" in the procedure on page 20.

Reading and entering key operations

You will notice that there is an illustration for each job entitled — Key operation. Each illustration shows how to enter the associated example into the machine, using the alphanumeric keys. The key operation for setting the register number is listed as:

2612 **◻** **⊗**(1)
123456 **◻** **TL**(2)

In "(1)" above, you would enter 2612, press the **◻** key, then press the **⊗** key. In "(2)" above, you would enter 123456 (for the example register number), then press the **TL** key. This completes the procedure.

In most cases, you end a procedure by pressing the **TL** key.

Recovering from an error message

If you happen to get an error beep and the message during programming, to recover and correct the condition, simply press the **CL** key. You will notice that the error message is cleared from the display and you can continue programming.

If you specify unavailable numbers for any parameters (described in "C Entering parameters" shown above), an error will occur. Pressing the **CL** key will clear the error and prompts you to enter the correct number. The cursor will show you the position you need to correct.

2 How to program alphanumeric characters

You can program alphanumeric characters for departments, PLUs, functions and so on in the character entry mode. If you enter a job number corresponding to an alphanumeric character programming job, your cash register automatically goes into the character entry mode. When you go into the character entry mode, the CHR. lamp lights up.

There are three ways for programming characters: by using character keys on the keyboard, by entering character codes with numeric keys on the keyboard and by using the optional programming remote keyboard. For details of the programming remote keyboard, see chapter "PROGRAMMING REMOTE KEYBOARD" on page 158.

■ By using character keys on the keyboard

For ER-A460

In the character entry mode, enter a character according to the position of the figure shown below.

		\$	(BACK SPACE)	(DC)	A	G	M	S	W
7	8	9			B	H	N	T	X
4	5	6			C	I	O	U	Y
1	2	3			D	J	P	V	Z
0					E	K	Q		
(SPACE)	(SHIFT)				F	L	R		

For ER-A470

In the character entry mode, enter a character according to the position of the figure shown below.

This is the programming key sheet that came with the ER-A470. This sheet is transparent allowing placement over the standard key sheet or the blank key sheet.

RECEIPT	JOURNAL	ç	œ	Pt	< {	> }	(v)	(^)	(**)	(\)	(/)	(//)	(a)	(~)	
T	Δ	Æ ^{EB}	∅	(DEL)	← ⁱ	→ ⁱ	◀	▶	↑	↓	"	"	'	?	
⊖	Λ	(←)	(→)	(BACK SPACE)		@	#	\$	%	^	&	* ^{!!}	([)]	
≡	π	⊗	•	CL	1	2	3	4	5	6	7	8	9	0	
Σ	Υ	7	8	9	Q	W	E	R	T	Y	U	I	O	P	
Φ	Ψ	4	5	6	A	S	D	F	G	H	J	K	L	/	
Ω	□	1	2	3	B	Z	X	C	V	B	N	M	.	'	: i
(SHIFT)	(DC)	0	00	000	ST	TL	(SPACE)	(SPACE)	(SPACE)	(SPACE)	(SPACE)	=	- ^{\$}	+ [£]	

Note The shaded keys cannot be used as character keys.

- Numerals, letters and symbols are programmable simply by pressing the keys.
- Characters are possible to be entered in single size or in double size. **By default, the single-size character mode is selected.** To enter a character in double size, press the (DC) key before you enter the character. The DC lamp lights up. To return to the single-size character mode, press the (DC) key again.

Example

To program the word "SHARP" in double size, do the following key-in.



- Letters of alphabets "A" through "Z" are possible to be entered in lower case or in upper case. **By default, the upper-case letter mode is selected.** To enter a character in lower case, press the (SHIFT) key before you enter the character. The SML lamp lights up. To return to the upper-case letter mode, press the (SHIFT) key again. The (SHIFT) key also allows you to enter the characters shown at the upper right of keys. For example, you can enter "!" of the (') key by using the (SHIFT) key.

Example

To program the word "Sharp", do the following key-in.



- "(^)", "(v)", "(~)", "(o)", "(**)", "(r)" "(s)", and "(r)" keys are used only for combination with a character key. If the combination is unavailable, only a character key is entered.

Example

To enter "Ä", do the following:

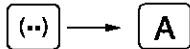

Editing the characters

You can edit the characters you entered. Pressing a character key replaces the current character with a new one. To edit the characters, use the following keys on the programming key sheet:

- (DEL): Deletes the character at the cursor position.
- (BACK SPACE): Backs up the cursor, erasing the character to the left.
- (←): Moves the cursor one space left.
- (→): Moves the cursor one space right.

■ By entering character codes

- Numerals, letters and symbols are programmable by entering the character code and (00) key. See the alphanumeric character code table on the next page. In this way, you can program characters other than the characters on the programming key sheet.

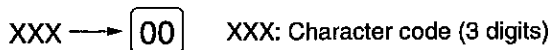

- Double-size characters can be made by entering the character code 253.

Example

To program the word "SHARP" in double size

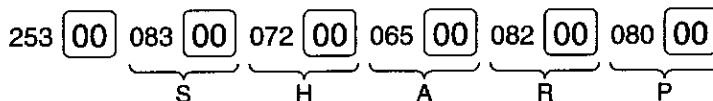

■ By using character keys on the programming remote keyboard

See chapter "PROGRAMMING REMOTE KEYBOARD" on page 158.

Alphanumeric character code table

Code	Character	Code	Character	Code	Character	Code	Character	Code	Character	Code	Character
001	á	033	!	065	A	097	a	129	1	161	°
002	â	034	”	066	B	098	b	130	2	162	⌈
003	ê	035	#	067	C	099	c	131	3	163	⌋
004	î	036	\$	068	D	100	d	132	4	164	˘
005	ì	037	%	069	E	101	e	133	1/2	165	·
006	í	038	&	070	F	102	f	134	F/T	176	☐
007	ô	039	,	071	G	103	g	135	←	177	Á
008	ó	040	(072	H	104	h	136	→	178	Í
009	û	041)	073	I	105	i	137	∞	192	Ç
010	ú	042	*	074	J	106	j	138	∞	193	ì
011	œ	043	+	075	K	107	k	139	◀	194	Ĝ
012	û	044	,	076	L	108	l	140	▶	195	Ş
013	ú	045	-	077	M	109	m	141	F	224	*
014	đ	046	.	078	N	110	n	142	T	225	Ş
015	ó	047	/	079	O	111	o	143	↓	226	∅
016	Λ	048	0	080	P	112	p	144	ç	228	↑
017	Ψ	049	1	081	Q	113	q	145	°	229]
018	Γ	050	2	082	R	114	r	146	ı	230	[
019	”	051	3	083	S	115	s	147	ù	231	“
020	Ω	052	4	084	T	116	t	148	à	232	ä
021	Δ	053	5	085	U	117	u	149	Æ	233	ö
022	Θ	054	6	086	V	118	v	150	ø	234	û
023	Ξ	055	7	087	W	119	w	151	Å	235	æ
024	π	056	8	088	X	120	x	152	□	236	â
025	Σ	057	9	089	Y	121	y	153	é	237	É
026	Υ	058	:	090	Z	122	z	154	è	238	ñ
027	Φ	059	;	091	Ä	123	{	155	Pt	253	DC*
028	Ů	060	<	092	Ö	124		156	i		
029	Ú	061	=	093	Ü	125	}	157	Ñ		
030	Ó	062	>	094	^	126	ß	158	ò		
031	Ó	063	?	095	_	127	¢	159	£		
032	(SPACE)	064	@	096	’	128	!!	160	¥		

* DC: Double-size character code

PROGRAMMING

Your machine allows you to program in two modes: PGM1 and PGM2. The PGM1 mode is for programming those items that need to be changed often: unit prices of departments/PLUs, and percentages. The PGM2 mode is used for programming all PGM1-mode programs and those items that require less frequent changes: date, time, tax rate, and the functions of each key. We describe below the programming or setting procedures of various items.

Program every item necessary for your store following the appropriate procedures.

* To set the mode switch to the PGM1 position, use the manager or submanager key; and to set to the PGM2 position, use the manager key.

■ Preparations for programming

1. Plug your machine into a standard wall outlet, and turn on the power switch.
2. Put the manager or submanager key in the mode switch and turn it to the PGM1 or PGM2 position depending upon the programming you are about to do.
3. Check to see whether both journal and receipt rolls are present in the machine. If they are missing, install journal and receipt paper rolls correctly referring to the procedure in "4. Installing and removing the paper roll" under "OPERATOR MAINTENANCE".
4. Program necessary items into your machine.

1 Setting the date and time

■ Setting the date PGM 2 2610

Enter day (one or two digits), month (two digits), and year (two digits) in this sequence.

Procedure

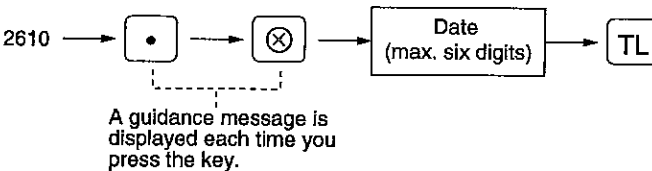

Example

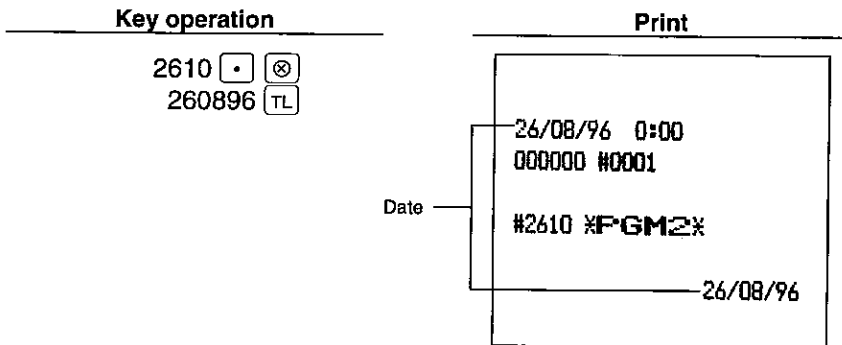

■ Setting the time PGM 2 2611

Set the time using the 24-hour format. For example, when the time is set to 2:30 AM, enter 230; and when it is set to 2:30 PM, enter 1430.

Procedure

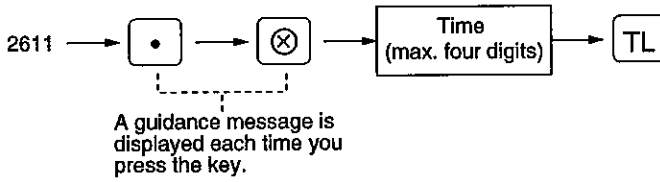

Example

Key operation

2611
1430

Print

```
26/08/96 14:30
000000 #0002
#2611 *PGM2*
14:30
```

Time

2 Setting the register and consecutive numbers

■ Setting the register number PGM 2 2612

When your store has two or more registers, it is practical to set separate register numbers for their identification. You may set them in a maximum of six digits.

Procedure

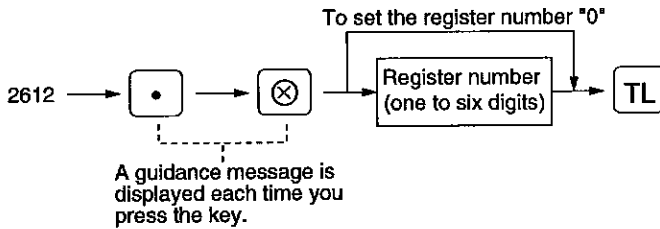

Example

Key operation

2612
123456

Print

```
26/08/96 14:30
123456 #0003
#2612 *PGM2*
123456
```

Register number

■ Setting the consecutive number PGM 2 2613

The consecutive number is increased by one each time a receipt is issued.
Enter a number (one to four digits) that is one less than the desired starting number.

Procedure

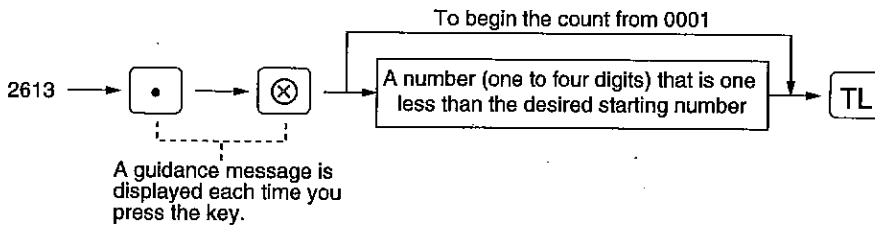

Example

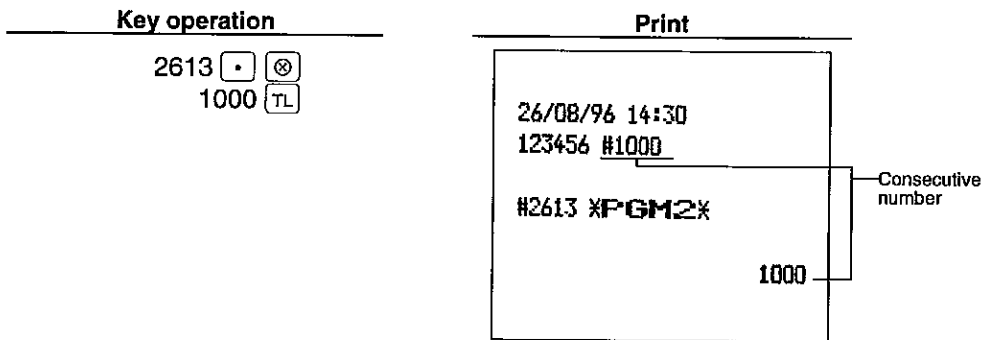

3 Programming the tax rate

■ Programming PGM 2 2711

Procedure

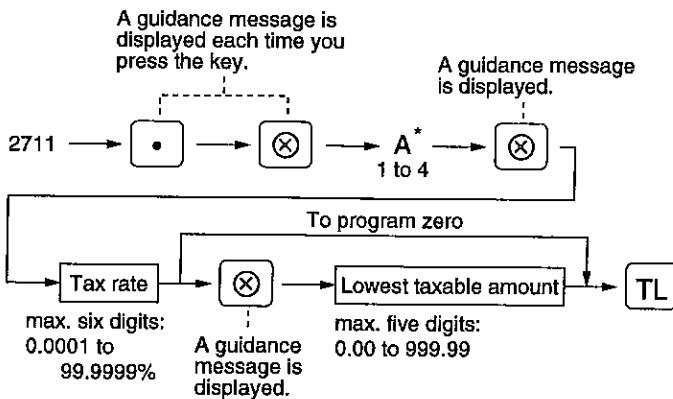

*A: Enter a corresponding tax rate number. For example, when you program a tax rate as tax rate 1, enter "1" and when you program it as tax rate 4, enter "4".

Example

Key operation

2711 [.] [⊗]
2 [⊗]
4 [⊗]
12 [TL]

Print

#2711 #FGM2#	
TAX2	4.0000%
	0.12

Note

- The lowest taxable amount is valid only when you select add on tax system. If you select VAT (Value added tax) system, it is invalid.
- If you make an incorrect entry before pressing the third [⊗] key in programming a tax rate, cancel it with the [CL] key; and if you make an error after pressing the third [⊗] key, cancel it with the [ST] key. Then program again from the beginning correctly.

4 Programming for departments

Your machine is equipped with:

- 18 standard departments and up to 50 optional departments (For ER-A460).
- 12 standard departments and up to 50 optional departments (For ER-A470).

Your machine allows you to perform the following programming for each department:

Functional programming PGM 2 2110

You can set each department for:

Printing a department on the cashier report

You can set a department so that the sales total for it is printed on the cashier report.

Compulsory item validation print

If item entries must be validated, program corresponding departments for compulsory item validation print.

SICS (Single item cash sale)

- SICS

If the first registration is to a department set for SICS, the sale is finalized as soon as the department key is pressed. If the sale is preceded by registrations to departments not set for SICS, a sale to a department set for SICS does not finalize and can be repeated until the [TL] key is pressed.

- SIF

Whenever a sale is made to a department set for SIF, the sale is finalized as soon as the department key is pressed.

Type of unit price entry

You may select one of the following four types of unit price entry for each department.

- Open and preset
- Preset only
- Open only
- Inhibit department key

Procedure

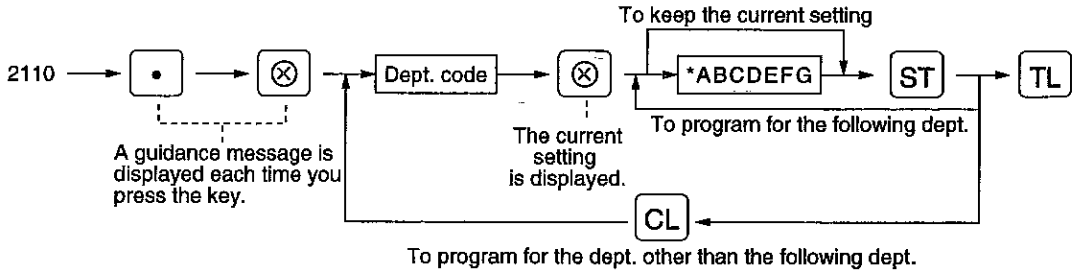

* Item:	To:	Enter:
A Printing on the cashier report	set a department to be printed on the cashier report	1
	set it not to be printed on the cashier report	0
B Item validation print compulsory/ non-compulsory	set a department for item validation print compulsory	1
	set it for item validation print non-compulsory	0
C Always enter 0.	(Fixed position)	0
D Always enter 0.	(Fixed position)	0
E SICS (Single item cash sale) /SIF/Normal	set a department for SIF	2
	set it for SICS	1
	set it for neither SIF nor SICS	0
F Always enter 0.	(Fixed position)	0
G Type of unit price entry	set a department for "Open and preset"	3
	set it for "Preset only"	2
	set it for "Open only"	1
	set it for "Inhibit department key"	0

Example

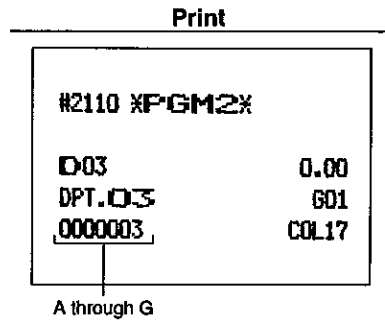
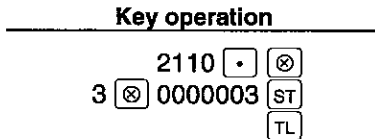

Tax status PGM 2 2111

Assign a tax status to each department.

When entries are made into taxable departments in a transaction, tax is automatically computed according to the associated tax rate as soon as the transaction is completed.

Procedure

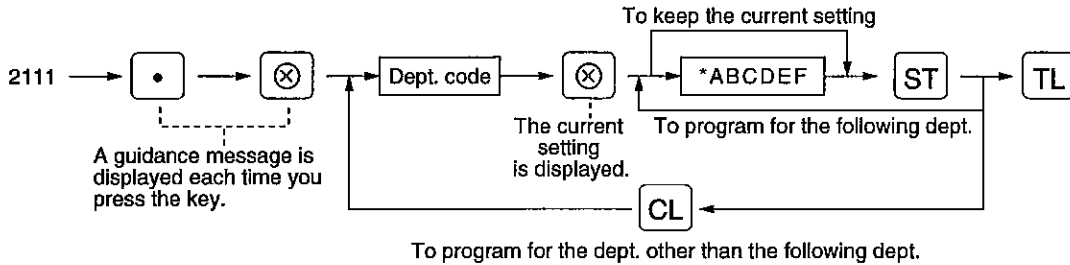

* Item:	To:	Enter:
A	Always enter 0. (Fixed position)	0
B	Always enter 0. (Fixed position)	0
C	VAT assign "non-taxable"	0
	assign "VAT "	1
D	VAT 3 or TAX 3 assign "non-taxable"	0
	assign "VAT 3 or TAX 3"	1
E	VAT 2 or TAX 2 assign "non-taxable"	0
	assign "VAT 2 or TAX 2"	1
F	VAT 1 or TAX 1 assign "non-taxable"	0
	assign "VAT 1 or TAX 1"	1

Note

- The tax system of your machine has been factory-set to automatic VAT1 - 3. If you desire to select any of automatic tax 1 - 3, manual VAT1 - 3, manual VAT1, manual tax 1 - 3, and the combination of the automatic VAT and the automatic tax 1 - 3, contact your dealer.
- When the combination of the automatic VAT and automatic tax 1 - 3 system is selected, one of the Tax 1(F), Tax 2(E) and Tax 3(D) can be selected in combination with VAT(C).
Example: CDEF = 1001, 1010, 1100

Example

Key operation

```

2111 [.] [X]
4 [X] 000101 [ST]
[CL] 10 [X] 000110 [ST]
[TL]
    
```

Print

```

#2111 XPGM2X
D04 T1 3 0.00 Tax status
DPT.04 G01
0000001 COL17
D10 T 23 0.00
DPT.10 G01
0000001 COL17
    
```

■ A limit amount (HALO) of entry PGM 2 2112

You can set upper limit amounts (HALO: High Amount Lockout) for each department. The limit is effective for the REG-mode operations and can be overridden in the MGR mode. HALO limit is represented by two figures as follows.

Procedure

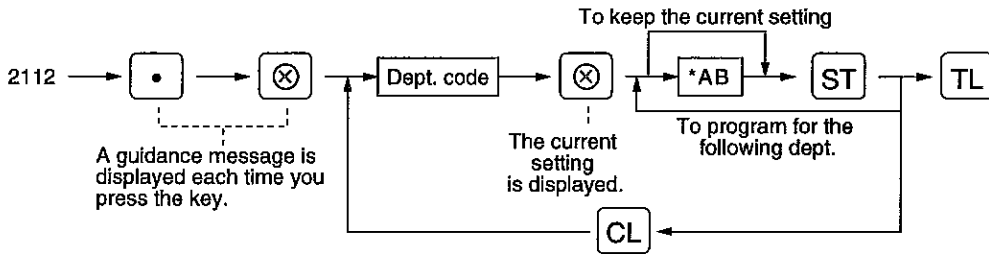

* AB is the same as $A \times 10^B$.

A: Significant digit (1 through 9)

B: Number of zeros to follow significant digit (0 through 7)

For example, presetting 14 (100.00) here means that amount entries of up to 100.00 are allowed in the REG mode. But when you preset 17, the upper limit amount is 99999.99.

Example

Key operation

```

2112 [.] [⊗]
1 [⊗] 95 [ST]
      [TL]
    
```

Print

#2112 *PGM2*	
D01	0.00
DPT.01	001
000001	COL95

HALO limit

■ Alphanumeric characters PGM 2 2114

You can program a maximum of twelve characters (item label) for each department. (However, the default setting is for an eight character label.)

Select the characters you want to program, referring to section "2 How to program alphanumeric characters" in chapter "PRIOR TO PROGRAMMING".

Procedure

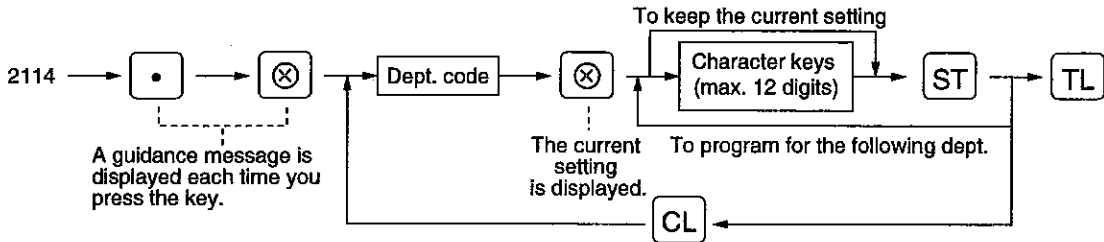

Example

Key operation

2114 . X
1 X
(DC) S (DC) TEAK SPACE ST
TL

Print

```
#2114 *PGM2*

D01          0.00
STEAK        G01
0000001     COL95
```

Text programmed for dept. 1

Unit price PGM.1 PGM.2 1110

You can program unit prices in a maximum of six digits (9999.99). Even if a department is not programmed to allow the entry of preset unit prices in functional programming (job 2110), the department is automatically changed to allow the entry of preset unit prices by this programming.

Procedure

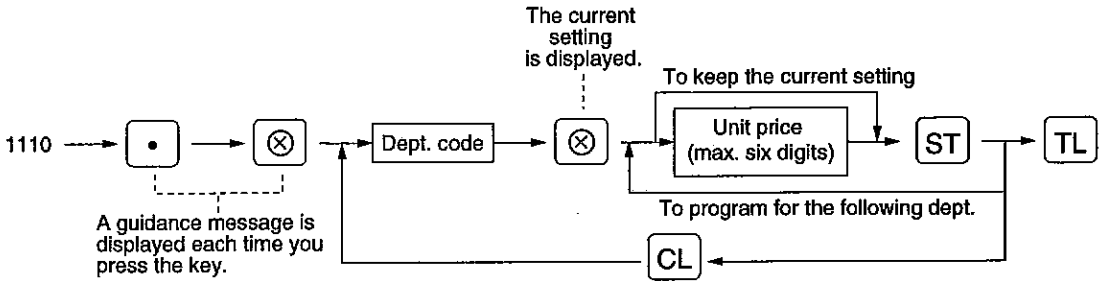

Example

Key operation

```

1110 • ⊗
1 ⊗ 1000 ST
      TL
    
```

Print

```

#1110 *PGM2*
D01          10.00 Unit price
STEAK        G01
0000003     C0L95
    
```

Commission group assignment PGM.2 2115

Your machine allows you to assign a commission group (1 - 3) to each department.

Procedure

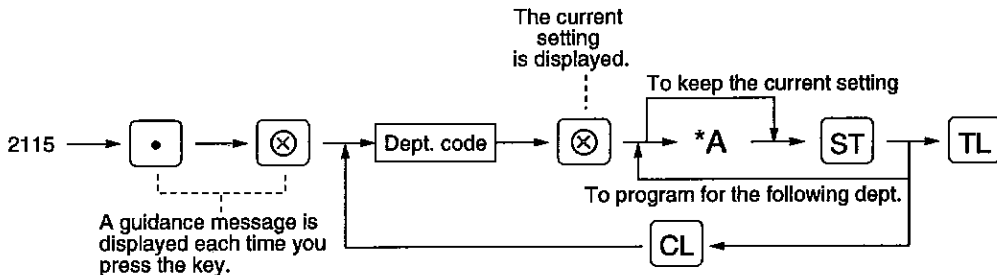

*A: Commission group 0 - 3 (0 = no commission)

Example

Key operation

```

2115 • ⊗
1 ⊗ 1 ST
CL 5 ⊗ 2 ST
      TL
    
```

Print

```

#2115 *PGM2*
D01          10.00
STEAK        G01
0000003     C1L95
D05          0.00
DPT.05      G01
0000001     C2L17
    
```

Commission group number

■ Group number PGM 2 2116

You can assign departments to a maximum of 14 groups (1 through 14).
Assign desired departments to any of the groups.
This programming enables you to take group sales reports.

Procedure

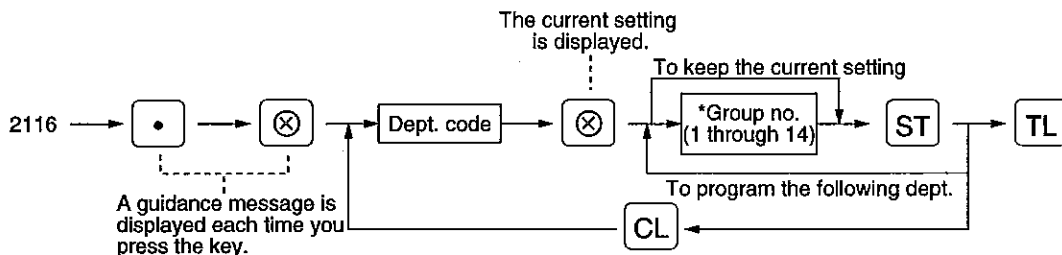

*Group number: Dept. (+) 1 through 9 (groups 1 through 9)
 Dept. (-) 10
 Hash (+) dept. 11
 Hash (-) dept. 12
 Bottle return (+) dept. 13
 Bottle return (-) dept. 14

Example

Key operation

```
2116 [.] [X]
      1 [X] 1 [ST]
           2 [ST]
           [TL]
```

Print

```
#2116 XPGM2X
```

```
D01                    10.00
STEAK                   601
0000003                C1L95
D02                    0.00
DPT.02                   602
0000001                COL17
```

Group no.

Note

The standard model provides no hash dept./bottle return dept. If you need them, please consult your dealer.

■ Key number assignments for departments PGM 2 2119

You can assign a department number to each key position. Each key position has a corresponding key number. To assign the department to a key position, select a key number of the position. You will find the desired key number in "Standard key number layout" section on page 13.

Procedure

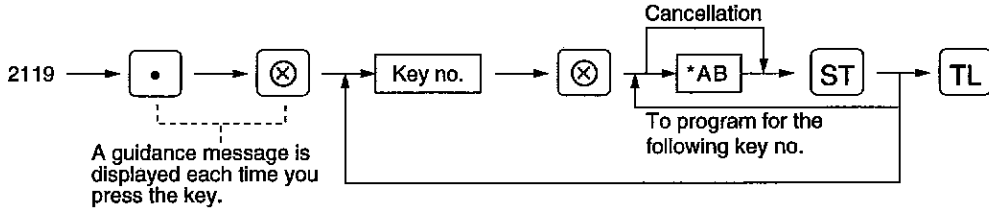

* AB is a department code.

Example

Key operation

```

2119 • ⊗
101 ⊗ 1 ST
      2 ST
      TL
  
```

Print

```

#2119 *PGM2*
101 L1   D01
102 L1   D02
  
```

Key no.
Dept. code

5 Price lookup (PLU) programming

Your machine has two kinds of PLU registration methods.

Direct PLU registration: Accomplished by depressing item key (direct PLU key) directly.

Indirect PLU registration: Accomplished by making an entry of PLU code and pressing the **PLU/SUB** key.

Each PLU requires you to program the following:

PLU code (six digits)

Associate department

When a PLU is associated with a department, the following functions of the PLU depend on the programming for the department.

- Grouping (group 1 through 14)
- Single item cash sale/Single item finalize
- HALO (only for subdepartments)
- Item validation print compulsory/non-compulsory

Unit price (max. six digits)

You will usually have unit prices programmed for individual PLUs as PLU unit prices.

If you program unit price "0" for a PLU, you can enter only the selling quantity into the PLU, i.e. the PLU can be used only as a counter.

Base quantity for split-pricing entries - two digits

Program a base quantity for each PLU/subdepartment dedicated to split-pricing entries.

Sign (+/-)

The function of every PLU/subdepartment varies according to the combination of its sign and its associate department's sign as follows.

Sign		Function of PLU/subdepartment
Dept.	PLU/subdept.	
+	+	Serves as a normal plus PLU/subdept.
-	-	Serves as a normal minus PLU/subdept.
+	-	Accepts store coupon entries, but not split-pricing entries.
-	+	Not valid; not accepted.

Tax status

Item label (8 characters) (max. 12 characters)

Commission group (1 to 3)

Set PLU

You can link a maximum of 10 PLUs to a particular PLU. Only the quantity is totalized for the linked PLUs.

Link PLU

PLU is able to link with any other PLU (e.g. bottle deposit). However, the number of links is a maximum of 5.

Even if more than 5 PLUs are linked, the sixth or higher link is not actualized.

PLU level assignment and direct PLU key positioning

PLU, subdepartment, PLU/subdepartment, delete, or prohibit mode

- If the PLU mode (i.e. automatic preset amount entry) is selected, individual PLU entries can be made by entering the assigned code and depressing the **PLU/SUB** key (or by depressing a direct PLU key without any code entry).
- If the subdepartment mode is selected, the **AMT** key must be depressed after the price entry followed by the PLU code entry. The entry is finalized by the **PLU/SUB** key depressed.
- If the PLU/subdepartment mode is selected, the entries in both the PLU and subdepartment modes are available.
- If the delete mode is selected, data programmed for each PLU is deleted.
- If the prohibit mode is selected, the assigned PLU code cannot be entered. This mode does not clear the PLU/subdepartment program data.

Stock quantity

Note

For some items, you can program in two ways: programming an individual PLU code and for a range of sequential PLU codes. The procedure marked "For each PLU" shows individual PLU programming. "For a range of PLUs" shows range PLU programming.

Department assignment **PGM 1** **PGM 2** **1200** **2230**

Procedure

For each PLU

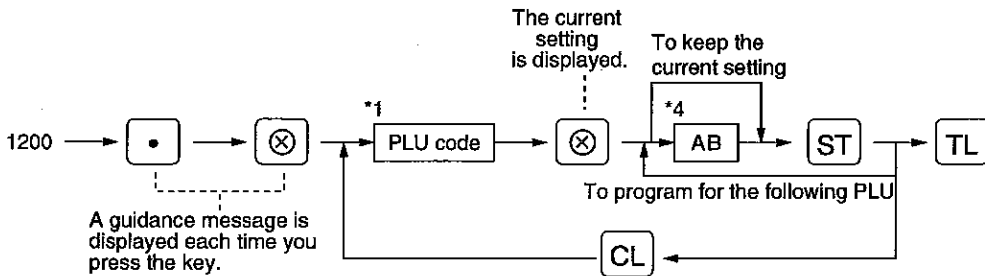

When the next PLU code does not directly follow the one just entered.

Note

As soon as the programming is completed for one PLU, the next PLU code appears in the display.

For a range of PLUs

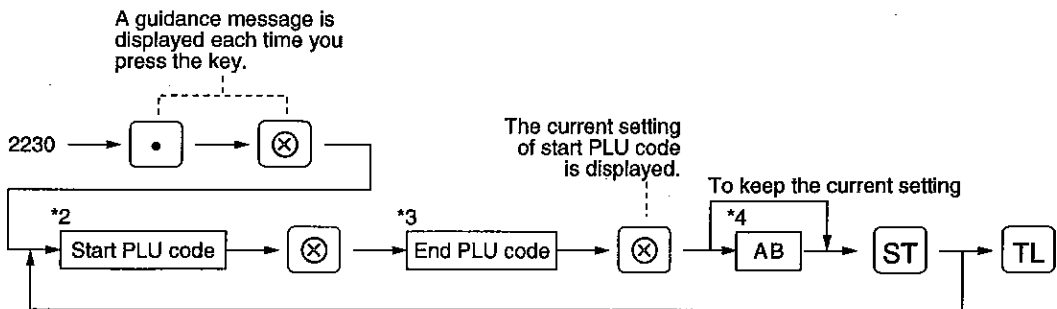

*1, 2, 3: 1 to 999999 (free code)

*4: AB: Associate department code

Example

For each PLU

Key operation

1200 . ⊗
 1 ⊗ 2 ST
 2 ST
 TL

Print

```
#1200 XPGM2%
F000001(O2) /00
          0.00
PL000001    CO
002
F000002(O2) /00
          0.00
PL000002    CO
002
```

PLU code

Associate dept.

For a range of PLUs

Key operation

2230 . ⊗
 11 ⊗ 20 ⊗
 3 ST
 TL

Print

```
#2230 XPGM2%
F000011 -P000020
      (O3)
```

PLU range

Associate dept.

Unit prices PGM 1 PGM 2 1210

Procedure

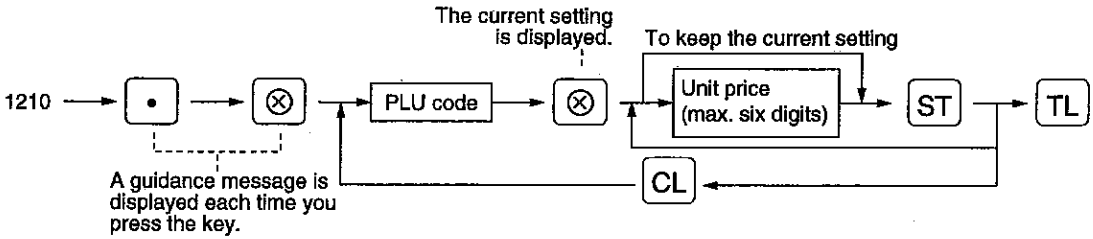

Example

Key operation

1210 . ×
 1 × 125 ST
TL

Print

#1210 *PGM2*	
F000001(O2)	/00
FL000001	1.25 — Unit price
002	CO

Base quantity PGM 1 PGM 2 1211

Procedure

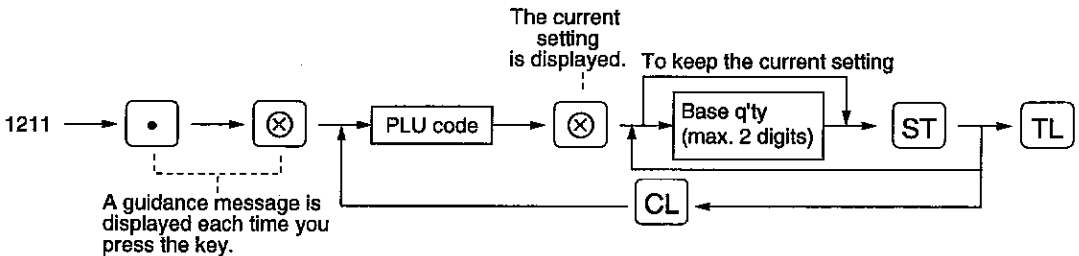

Example

Key operation

1211 . ×
 2 × 12 ST
TL

Print

#1211 *PGM2*	
F000002(O2)	/12 — Base q'ty
FL000002	0.00
002	CO

■ Sign (+/-) and tax status PGM 2 2211 2232

Procedure

For each PLU

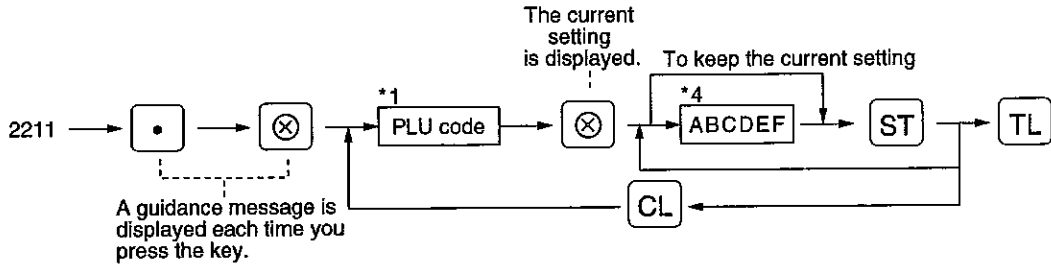

For a range of PLUs

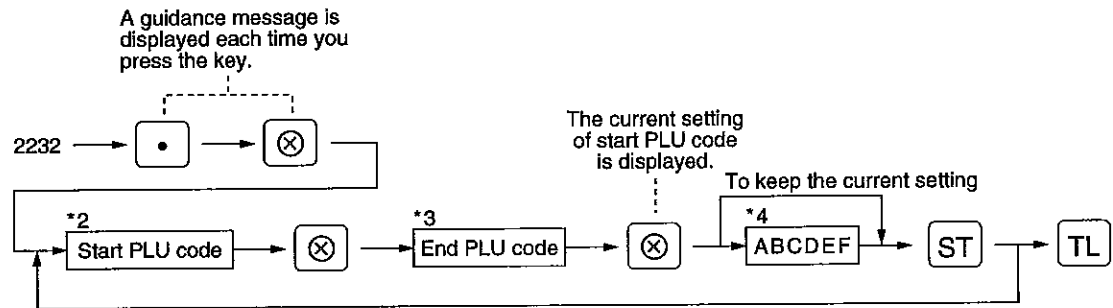

*1,2,3: 1 through 999999

*4: Item:	to:	Enter:
A	Sign (+/-) set as a plus PLU	0
	set as a minus PLU	1
B	Always enter 0. (Fixed position)	0
C	VAT assign "non-taxable"	0
	assign "VAT "	1
D	VAT 3 or TAX 3 assign "non-taxable"	0
	assign "VAT 3 or TAX 3"	1
E	VAT 2 or TAX 2 assign "non-taxable"	0
	assign "VAT 2 or TAX 2"	1
F	VAT 1 or TAX 1 assign "non-taxable"	0
	assign "VAT 1 or TAX 1"	1

Note

- The tax system of your machine has been factory-set to automatic VAT1 - 3. If you desire to select any of automatic tax 1 - 3, manual VAT1 - 3, manual VAT1, manual tax 1 - 3, and the combination of the automatic VAT and the automatic tax 1 - 3, contact your dealer.
- When the combination of the automatic VAT and automatic tax 1 - 3 system is selected, one of the Tax 1(F), Tax 2(E) and Tax 3(D) can be selected in combination with VAT(C). Example: CDEF = 1001, 1010, 1100
- A PLU not programmed for any of these tax statuses is registered depending on the tax status of the department which the PLU belongs to.

Example

For each PLU

Key operation

2211 . ⊗
 1 ⊗ 000001 ST
 000000 ST
 TL

Print

```
#2211 *PGM2*

P000001(O2)      /00
  T1 _____  1.25
PL000001         CO
002
P000002(O2)      /12
                   0.00
PL000002         CO
002
```

Taxable 1

For a range of PLUs

Key operation

2232 . ⊗
 11 ⊗ 20 ⊗
 000001 ST
 TL

Print

```
#2232 *PGM2*

P000011 _____ -P000020
  T1 _____
```

PLU range

Taxable 1

■ Alphanumeric characters PGM 2 2214

You can program a maximum of twelve characters (item label) for each PLU or subdepartment. (However, the default setting is for an eight-character label.) Refer to section "2 How to program alphanumeric characters" in chapter "PRIOR TO PROGRAMMING".

Procedure

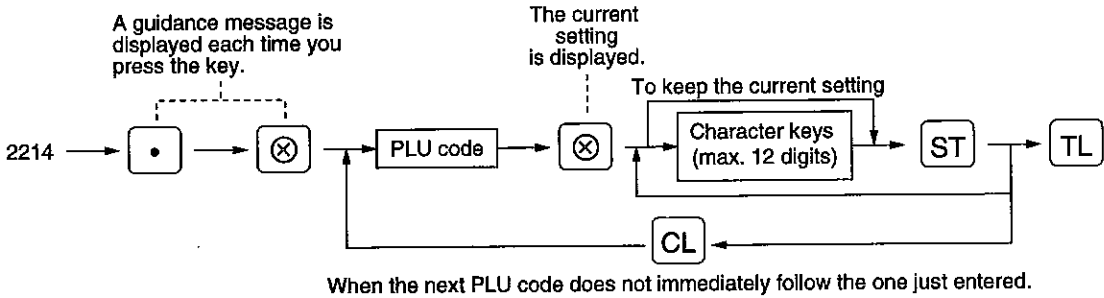

Note *PLU codes must have already been defined.*

Example

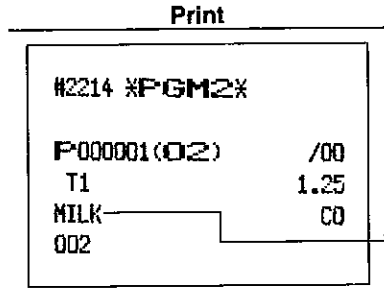
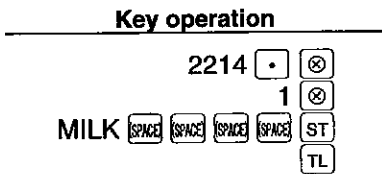

Assigning of PLUs to commission groups PGM 2 2215 2235

You can assign PLUs (or subdepartments) to commission groups.

Procedure

For each PLU

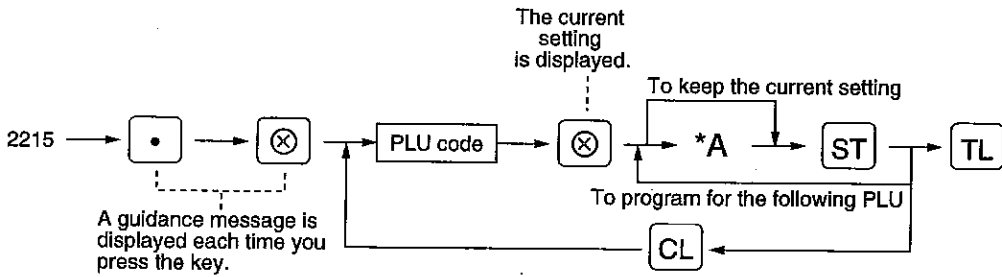

For a range of PLUs

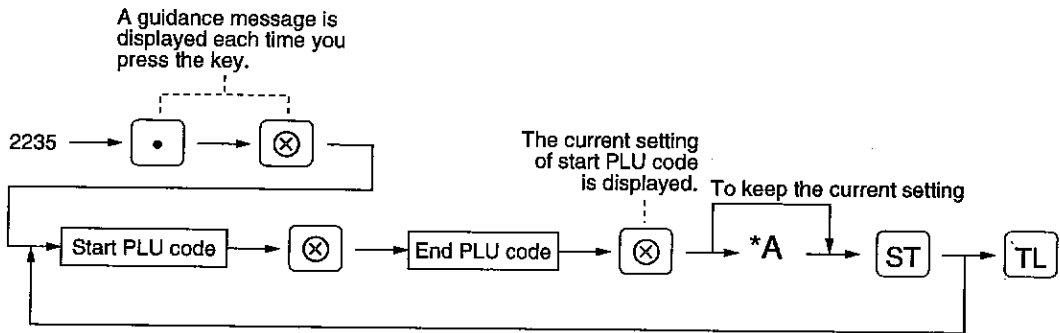

*A: Commission group 0 - 3 (0= no commission)

Note PLU codes must have already been defined.

Example

For each PLU

Key operation	Print
2215 <input type="text" value="."/> <input type="text" value="⊗"/> 1 <input type="text" value="⊗"/> 1 <input type="text" value="ST"/> <input type="text" value="TL"/>	<pre>#2215 XPGM2X P000001 (02) /00 T1 1.25 MILK C1 002</pre> <div style="text-align: right; margin-top: 10px;"> Commission group number </div>

For a range of PLUs

Key operation	Print
2235 <input type="text" value="."/> <input type="text" value="⊗"/> 12 <input type="text" value="⊗"/> 14 <input type="text" value="⊗"/> 1 <input type="text" value="ST"/> <input type="text" value="TL"/>	<pre>#2235 XPGM2X P000012 -P000014 C1</pre> <div style="text-align: right; margin-top: 10px;"> PLU range Commission group number </div>

■ Set PLU PGM 2 2221

Procedure

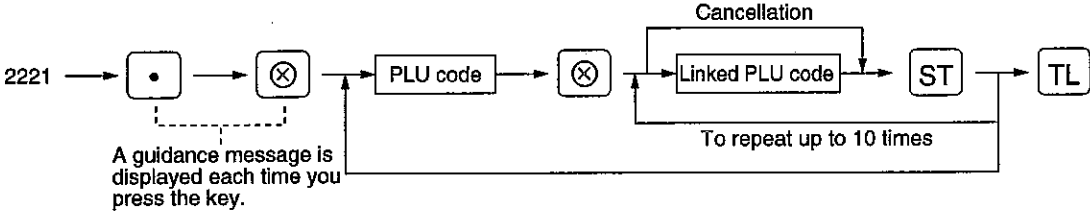

Note PLU codes must have already been defined.

Example

Key operation	Print
<pre> 2221 [.] [X] 20 [X] 201 [ST] 202 [ST] [TL] </pre>	<div style="border: 1px solid black; padding: 5px; width: fit-content;"> <pre> #2221 *PGM2* F000020 SP000201 P000202 </pre> </div> <p style="margin-left: 150px;">Set PLU</p> <p style="margin-left: 150px;">Linked PLU</p>

■ Link PLU PGM 2 2220

Procedure

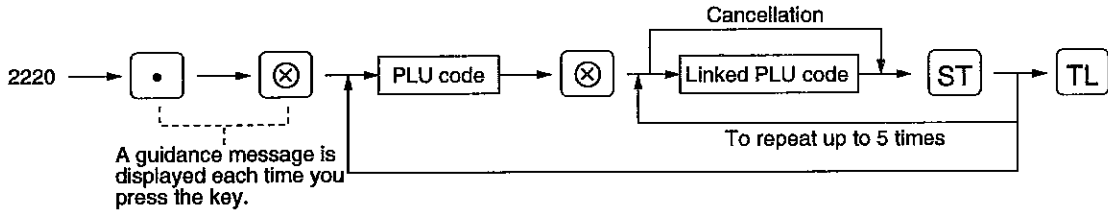

Note PLU codes must have already been defined.

Example

Key operation	Print
<pre> 2220 [.] [X] 21 [X] 25 [ST] 26 [ST] 27 [ST] [TL] </pre>	<div style="border: 1px solid black; padding: 5px; width: fit-content;"> <pre> #2220 *PGM2* F000021 LP000025 P000026 P000027 </pre> </div> <p style="margin-left: 150px;">Link PLU</p> <p style="margin-left: 150px;">Linked PLU</p>

■ Programming of PLU levels and direct PLU keys PGM.2 2219

You can assign PLU codes to fixed keys in each PLU level and use those keys as direct PLU keys. For assigning a PLU level, press the **L1**, **L2** or **L3** key. For example, if you want to assign PLU level 1 and key no.1 to a PLU code, press the **L1** key and enter 1 before entering the PLU code. For key no. position, refer to section "3 Standard key number layout" in chapter "KEYBOARD" on page 13.

Procedure

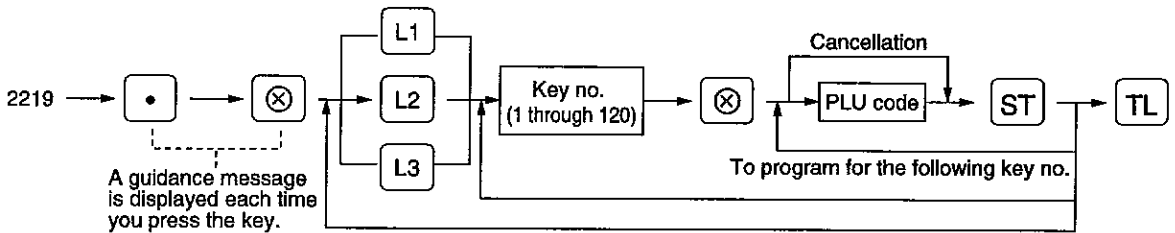

Note PLU codes must have already been defined.

Example Programming so that PLU code 1 (level 1) and 65 (level 2) are assigned to key no. 1

Key operation

```

2219 . ⊗
L1 1 ⊗
1 ST
L2 1 ⊗
65 ST
TL
    
```

Print

```

#2219 XPGM2X
001 L1 F000001
001 L2 F000065
    
```

Key no.
PLU level no.
PLU code

Procedure

For each PLU

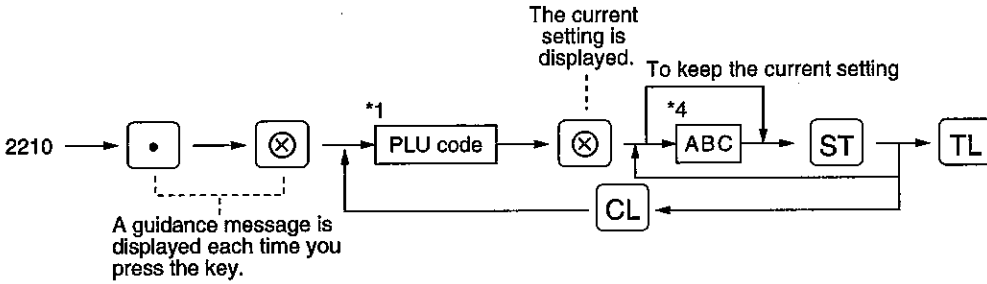

For a range of PLUs

If you use this programming, a range of PLU codes which you set will be created or deleted.

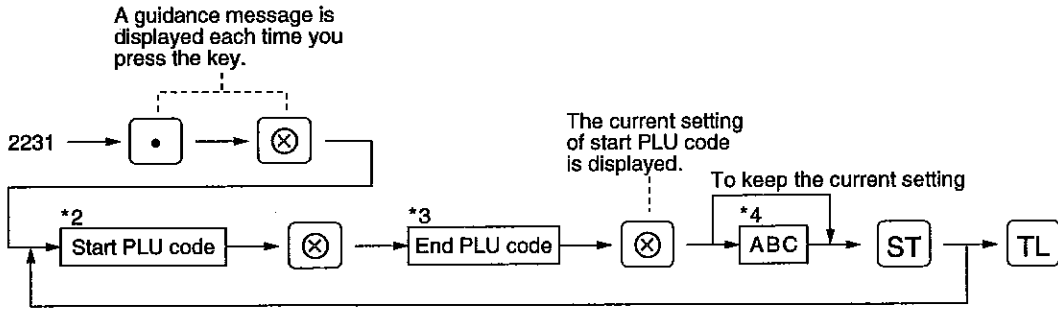

*1,2,3: 1 through 999999

*4: Item:	To:	Enter:
A	Always enter 0. (Fixed position)	0
B	Always enter 0. (Fixed position)	0
C	Mode parameter inhibit PLU/subdept.	0
	select the subdept. mode	1
	select the PLU mode	2
	select the PLU/subdept. mode	3
	select the delete mode	4

Example

For each PLU

Key operation

2210 [.] [⊗]
 1 [⊗] 003 [ST]
 [TL]

Print

```
#2210 *PGM2*

F000001 (02)      /00
  T1                1.25
  MILK              C1
  003
```

3: PLU/subdept. mode

For a range of PLUs

Key operation

2231 [.] [⊗]
 11 [⊗] 20 [⊗]
 003 [ST]
 [TL]

Print

```
#2231 *PGM2*

F000011          -F000020
  003
```

PLU range

3: PLU/subdept. mode

Stock quantity PGM.1 PGM.2 1222 1220 1221

For this programming, the optional RAM memory chip is needed.

When you use the optional RAM memory chip, contact your local dealer.

You can assign a stock quantity to each PLU code. When you assign it for the first time, do the following:

Procedure

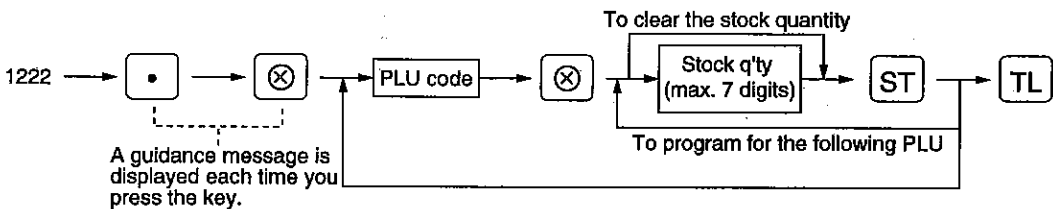

Example

Key operation

1222 [.] [⊗]
 2 [⊗] 10 [ST]
 [TL]

Print

```
#1222 *PGM2*

F000002          0.000
                  10.000
  S 10.000
```

Stock q'ty

Note

If you assign another stock quantity to the PLU code which you have assigned a stock quantity to, it will be overridden.

If you need to add or subtract a stock quantity, do the following:

Procedure

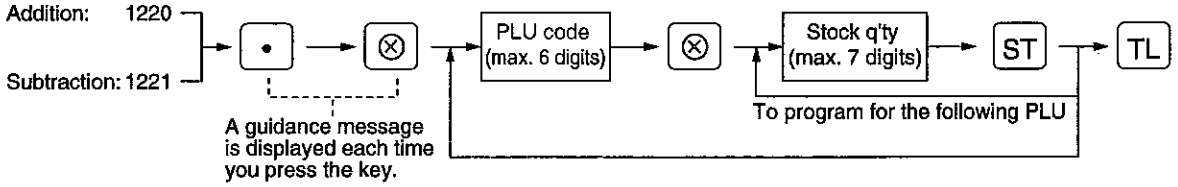

Adding the stock quantity

Example

Key operation	Print
<p>1220 [.] [⊗] 2 [⊗] 4 [ST] [TL]</p>	<div style="border: 1px solid black; padding: 5px; width: fit-content;"> <pre>#1220 *PGM2X F000002 10.000 4.000 S 14.000</pre> </div> <p style="margin-left: 200px;">← Added stock q'ty</p>

Subtracting the stock quantity

Example

Key operation	Print
<p>1221 [.] [⊗] 2 [⊗] 1 [.] 5 [ST] [TL]</p>	<div style="border: 1px solid black; padding: 5px; width: fit-content;"> <pre>#1221 *PGM2X F000002 14.000 -1.500 S 12.500</pre> </div> <p style="margin-left: 200px;">← Subtracted stock q'ty</p>

6 Programming for miscellaneous keys

Only function keys which you have programmed on the keyboard will be allowed the rate, HALO and tax status programming.

■ Programming the rate (%, EX, commission) and the deduction (⊖)

PGM 1 PGM 2 1310

You can program percent rates, currency exchange rates, discount amount and commission rates.

Procedure

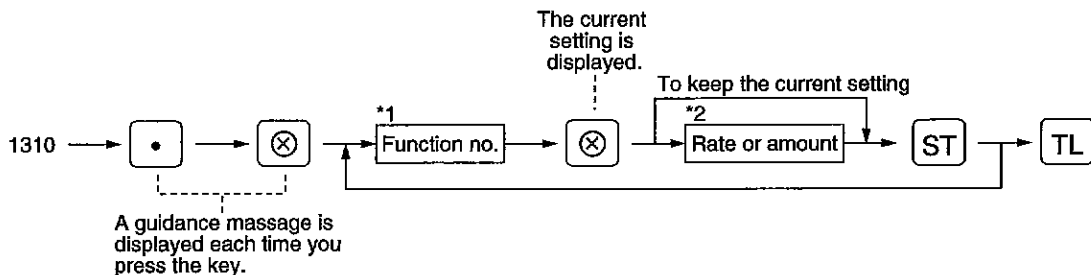

*1: Function no.

- | | |
|-------------------|-------------------------------|
| 1: For the ⊖1 key | 51: For the EX1 key |
| 2: For the ⊖2 key | 52: For the EX2 key |
| 3: For the ⊖3 key | 53: For the EX3 key |
| 4: For the ⊖4 key | 63: For the commission sale 1 |
| 5: For the %1 key | 64: For the commission sale 2 |
| 6: For the %2 key | 65: For the commission sale 3 |
| 7: For the %3 key | |
| 8: For the %4 key | |

To search a function number automatically, do the following:

- → 001 → • → 002 → • → 003 →
 • → 004 → • → 005 → • → 006 →
 • → 007 → • → 008 → • → 051 →
 • → 052 → • → 053 → • → 063 →
 • → 064 → • → 065 → • → Return to "001".

*2: Rate or amount

- 0 — 999999 (Deduction amount)
- 0.00 — 100.00 (% rate)
- 0.0000 — 9999.9999 (Currency exchange rate)
- 0.00 — 999.99 (commission rate)

Example

Key operation	
1310	• ⊗
1	⊗ 1000 ST
5	⊗ 10 • 25 ST
51	⊗ 0 • 6068 ST
	TL

Print	
#1310	*PGM2*
F001	(→) 1
S	-10.00 — Discount amount
	L17
F005	%1
S	-10.25% — Percent rate
	L100.00%
F051	EXCH1
	0.6068 — Currency exchange rate

Note You must use a decimal point to add fractional amount.

■ A limit amount (HALO) of entry (⊖, RA, PO) PGM 2 2312

The limit is in effect for the REG-mode operations but can be overridden in the MGR mode. The HALO limit is represented by two figures as follows:

Procedure

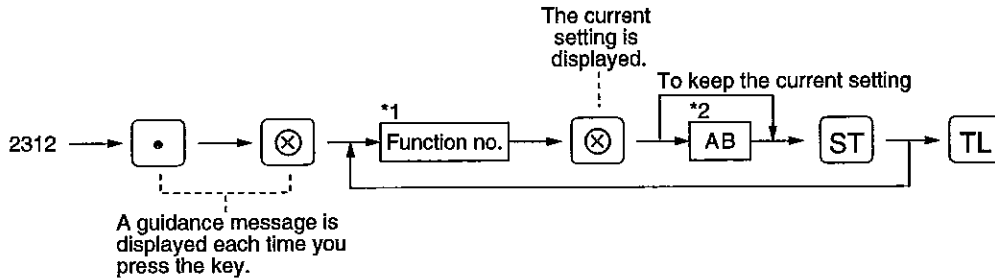

*1: Function no.

- | | |
|-------------------|---------------------|
| 1: For the ⊖1 key | 36: For the RA key |
| 2: For the ⊖2 key | 37: For the RA2 key |
| 3: For the ⊖3 key | 38: For the PO key |
| 4: For the ⊖4 key | 39: For the PO2 key |

To search a function number automatically, do the following:

- → 001 → • → 002 → • → 003 →
 • → 004 → • → 036 → • → 037 →
 • → 038 → • → 039 → • → Return to "001".

*2: AB is the same as $A \times 10^B$.

A: Significant digit (1 through 9)

B: Number of zeros to follow significant digit

0 through 7 (for the ⊖1 through ⊖4 keys)

0 through 8 (for the RA, RA2, PO, and PO2 keys)

For example, presetting 13 (10.00) here means that amount entries of up to 10.00 are allowed in the REG mode.

You can set up AB = 17 for no limitation (for the ⊖1 through ⊖4 keys).

You can set up AB = 18 for no limitation (for the RA, RA2, PO, and PO2 keys).

Example

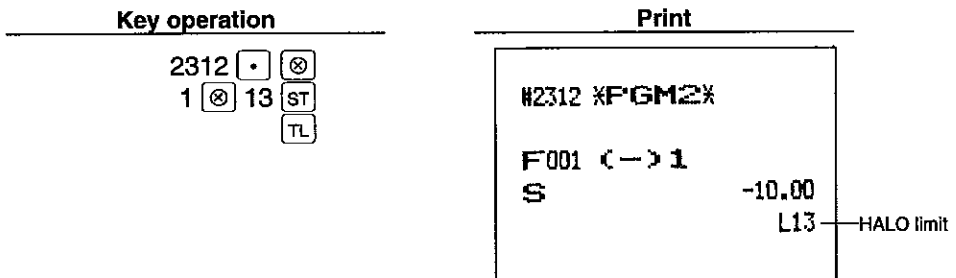

Procedure

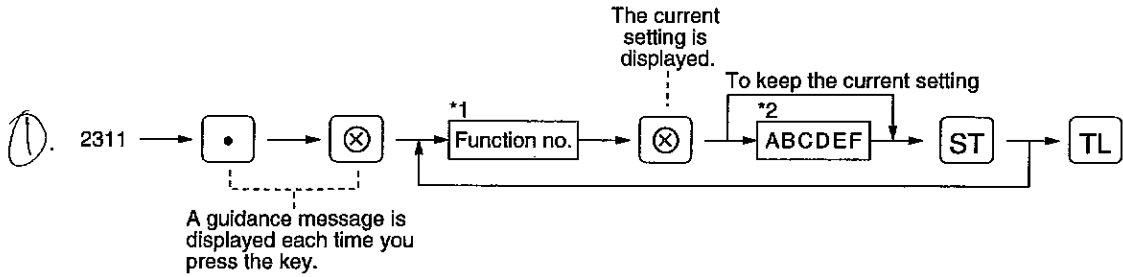

*1: Function no.

- 1: For the key
- 2: For the key
- 3: For the key
- 4: For the key
- 5: For the key
- 6: For the key
- 7: For the key
- 8: For the key

To search a function number automatically, do the following:

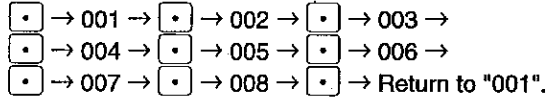

*2: As follows:

Item:	To:	Enter:
A +/- sign	select the + (premium) sign	0
	select the -(discount) sign	1
B to F	Always enter 0. (Fixed position)	0

Example

Key operation

2311 [.] [⊗]
 5 [⊖] 000000 [ST]
 6 [⊖] 100000 [ST]
 [TL]

Print

```
#2311 XPGM2X
F005 %1
S          10.25%
L100.00%
F006 %2
S          -15.00%
L100.00%
```

*-: Discount

■ % item or % subtotal selection ([%]) PGM 2 2315

% item

Select this when a percent calculation is to be made for department and PLU.

% subtotal

Select this when a percent calculation is to be made for subtotals.

Procedure

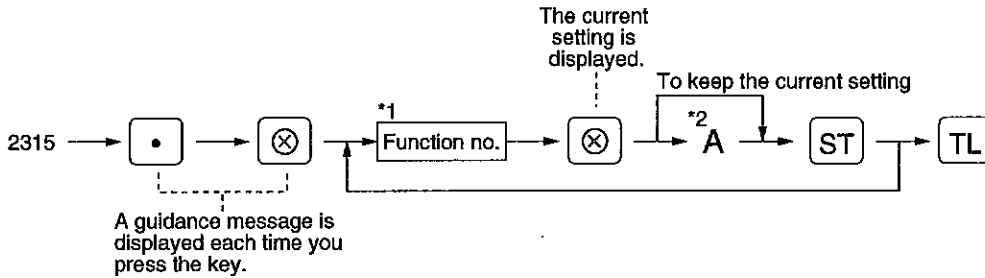

*1: Function no.

5: For the [%1] key

6: For the [%2] key

7: For the [%3] key

8: For the [%4] key

To search a function number automatically, do the following:

[.] → 005 → [.] → 006 → [.] → 007 →

[.] → 008 → [.] → Return to "005".

*2: A

0: % subtotal

1: % item

Example

Key operation

```

2315 . [X]
5 [X] 1 [ST]
6 [X] 0 [ST]
      [TL]
    
```

Print

```

#2315 %PGM2%

F005 %1
I          10.25% % item
L100.00%

F006 %2
S          -15.00% % subtotal
L100.00%
    
```

■ Percent rate limitation ([%]) PGM 2 2313

You can program the upper limit of percent rates for percent entries.

(Percent entries that use the upper limit are allowed.)

Procedure

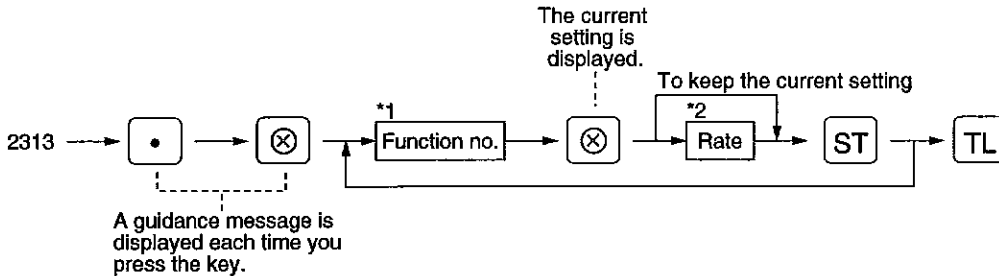

*1: Function no.

5: For the [%1] key

6: For the [%2] key

7: For the [%3] key

8: For the [%4] key

To search a function number automatically, take the same steps as in job 2315.

*2: Rate

0.00 – 100.00 (Entering 0.00 inhibits the open percent rate entry.)

Note 10.00% can be entered as $\boxed{1}\boxed{0}$ or $\boxed{1}\boxed{0}\boxed{\cdot}\boxed{0}\boxed{0}$. The $\boxed{\cdot}$ key is needed only for fractional entry.

Example

Key operation	Print
2313 $\boxed{\cdot}$ $\boxed{\otimes}$ 5 $\boxed{\otimes}$ 15 $\boxed{\cdot}$ 00 \boxed{ST} \boxed{TL}	<pre> #2313 *PGM2* F005 <-1 I 10.25% L 15.00% — Percentage limit </pre>

Item or subtotal selection ($\boxed{\ominus}$) PGM 2 2316

Procedure

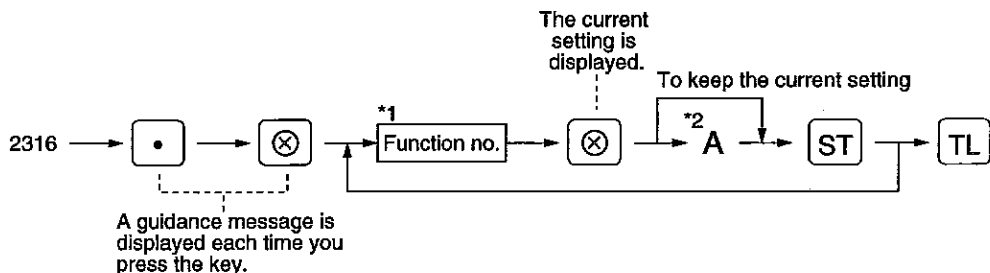

*1: Function no.

- 1: For the $\boxed{\ominus 1}$ key
- 2: For the $\boxed{\ominus 2}$ key
- 3: For the $\boxed{\ominus 3}$ key
- 4: For the $\boxed{\ominus 4}$ key

To search a function number automatically, do the following:
 $\boxed{\cdot}$ → 001 → $\boxed{\cdot}$ → 002 → $\boxed{\cdot}$ → 003 →
 $\boxed{\cdot}$ → 004 → $\boxed{\cdot}$ → Return to "001".

*2: A

- 0: \ominus subtotal
- 1: \ominus item

Example

Key operation	Print
2316 $\boxed{\cdot}$ $\boxed{\otimes}$ 1 $\boxed{\otimes}$ 1 \boxed{ST} 2 $\boxed{\otimes}$ 0 \boxed{ST} \boxed{TL}	<pre> #2316 *PGM2* F001 (-) 1 I -10.00 — Item ⊖ L13 F002 (-) 2 S -0.00 — Subtotal ⊖ L17 </pre>

7 Programming for the **TL**, **CA2**, **CH** through **CH4**, and **CR1** through **CR4** keys

■ Functional programming **PGM 2** **2320**

You can set each media for:

EFT transaction

Footer printing

This programming decides whether or not your machine should print a message at the foot of a receipt when a specified media key is used.

Non-add code compulsory

You can enforce the non-add code entry when a media entry is accepted.

Change enable (over-tender)

Either change enable or disable can be selected for a corresponding media key.

Compulsory validation print

If media entries must be validated, set the corresponding media for compulsory validation print.

Drawer open

You can program each media key to or not to open the drawer.

Amount tendered compulsory

You may select amount tendered compulsory or optional for **TL**, **CA2**, and **CH** through **CH4** keys.

You may select amount tendered compulsory or inhibited for **CR1** through **CR4** keys.

Procedure

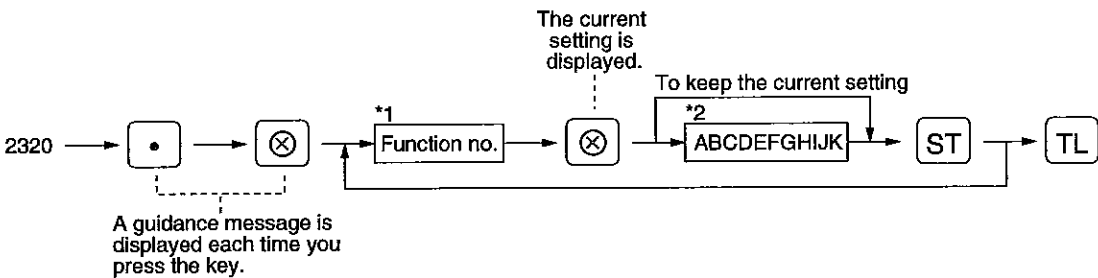

*1: Function no.

- | | |
|----------------------------|----------------------------|
| 41: For the TL key | 47: For the CR1 key |
| 42: For the CA2 key | 48: For the CR2 key |
| 43: For the CH1 key | 49: For the CR3 key |
| 44: For the CH2 key | 50: For the CR4 key |
| 45: For the CH3 key | |
| 46: For the CH4 key | |

To search a function number automatically, do the following:

- → 041 → • → 042 → • → 043 → • → 044 →
- → 045 → • → 046 → • → 047 → • → 048 →
- → 049 → • → 050 → • → Return to "041".

*2 Item:	To:	Enter:
A EFT transaction	select compulsory	1
	select non-compulsory	0
B Footer printing	select footer printing on selected media Yes	1
	select footer printing on selected media No	0
C Non-add code compulsory	select compulsory non-add code entry	1
	select optional non-add code entry	0
D Change enable (Over-tender enable)	select change disable	1
	select change enable	0
E Validation print compulsory	select compulsory validation	1
	select optional validation	0
F to I Always enter 0.	(Fixed position)	0
J Drawer open	have the drawer remain closed	1
	have the drawer open	0
K Compulsory amount tendered	select compulsory amount tendered	1
	select optional amount tendered for the TL, CA2 or CH to CH4 keys	0
	inhibit amount tendered for CR1 to CR4 keys	0

Example

Key operation

2320 [.] [⊗]
 49 [⊗] 0000000001 [ST]
 [TL]

Print

```

#2320 *FGM2X

F049 CREDIT3      L18
      0000000001
  
```

A through K

■ High amount lockout (HALO) for cheque cashing, cash in drawer and cheque change PGM 2 2321

You can program the upper limit amounts for cheque cashing, cash in drawer and cheque change.

Procedure

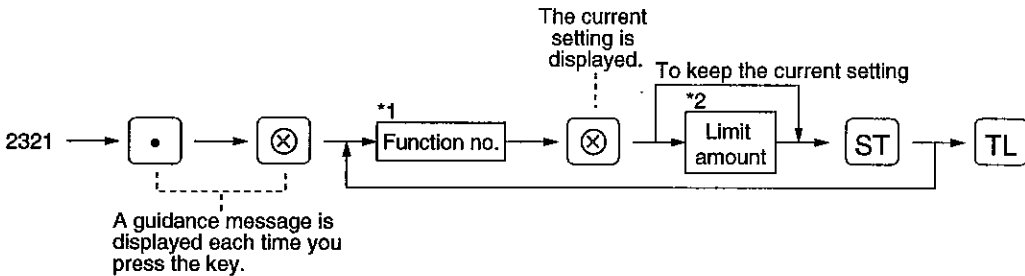

*1: Function no.

- 40: For cheque cashing
- 58: For cash in drawer
- 61: For cheque change

To search a function number automatically, do the following:

- → 040 → • → 058 →
- → 061 → • → Return to "040".

*2: Limit amount

- 0 through 999999.99 (Cheque change, cheque cashing)
- 0 through 9999999.99 (Cash in drawer)

Example

Key operation

2321 • ⊗
40 ⊗ 9999 ST
TL

Print

```
#2321 *PGM2*
F040 CA/CHK
99.99 — HALO limit
```

■ High amount lockout (HALO) of entry for media keys PGM 2 2322

The limit is in effect for the REG-mode operations but can be overridden in the MGR mode. HALO limit is represented by two figures as follows:

Procedure

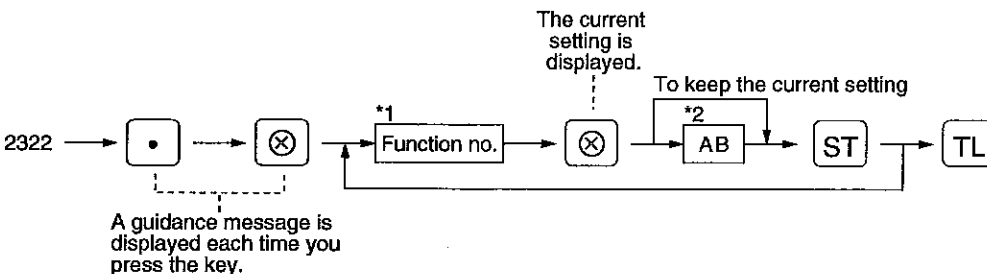

*1: Function no.

- 41: For the TL key
- 42: For the CA2 key
- 43: For the CH key
- 44: For the CH2 key
- 45: For the CH3 key
- 46: For the CH4 key
- 47: For the CR1 key

- 48: For the CR2 key
- 49: For the CR3 key
- 50: For the CR4 key

To search a function number automatically, take the same steps as in job 2320.

*2: AB is the same as $A \times 10^B$.

- A: Significant digit (1 through 9)
- B: Number of zeros to follow significant digit (0 through 8)

You can set up AB = 18 for no limitation

Example

Key operation

2322 [.] [⊗]
 49 [⊗] 15 [ST]
 [TL]

Print

```
#2322 *PGM2*
F049 CREDIT3      L15 HALO limit
                   0000000001
```

8 Programming of function text

Programming PGM 2 2314

You can program a maximum of 8 characters for each function key and other functions using the table on the next page.

Refer to section "2 How to program alphanumeric characters" in chapter "PRIOR TO PROGRAMMING".

Procedure

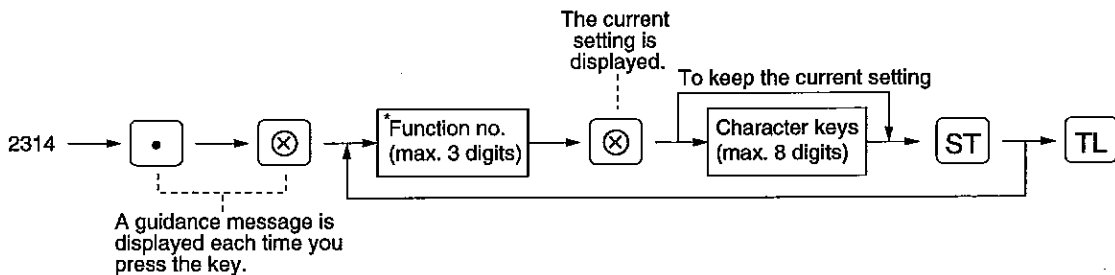

*Function no. : See "List of function texts" on the next page.

Example

Key operation

2314 [.] [⊗]
 41 [⊗] [DC] C [DC] ASH [ST]
 [TL]

Print

```
#2314 *PGM2*
F041 CASH          L18
                   0000000000
```

■ List of function texts

Function no.	Key or function	In default of programming	Function no.	Key or function	In default of programming
1	⊖ 1	(-)1	51	Exchange 1	EXCH1
2	⊖ 2	(-)2	52	Exchange 2	EXCH2
3	⊖ 3	(-)3	53	Exchange 3	EXCH3
4	⊖ 4	(-)4	54	Exchange 4	EXCH4
5	%1	%1	55	Exchange 1 is	EXCH1 IS
6	%2	%2	56	Exchange 2 is	EXCH2 IS
7	%3	%3	57	Exchange 3 is	EXCH3 IS
8	%4	%4	58	Cash in drawer	****CID
9	Set PLU discount	SET PLU-	59	Cash/cheque is	CA/CH IS
10	Differ	DIFFER	60	Cash/cheque in drawer	CA/CH ID
11	Taxable 1 subtotal	TAX1 ST	61	Change for cheque	CHK/CG
12	Taxable 2 subtotal	TAX2 ST	62	Guest	GUEST
13	Taxable 3 subtotal	TAX3 ST	63	Commission sale 1	COM.SAL1
14	Taxable subtotal	TAX ST	64	Commission sale 2	COM.SAL2
15	VAT/tax 1	VAT 1	65	Commission sale 3	COM.SAL3
16	VAT/tax 2	VAT 2	66	Non commission sale	NON COM.
17	VAT/tax 3	VAT 3	67	Order total	ORDER TL
18	VAT	VAT	68	Paid total	PAID TL
19	Net 1	NET1	69	Domestic currency 1	DOM.CUR1
20	Net 2	NET2	70	Domestic currency 2	DOM.CUR2
21	Coupon-like PLU	CP PLU	71	Domestic currency 3	DOM.CUR3
22	Refund	REFUND	72	Domestic currency 4	DOM.CUR4
23	∞	∞	73	Cheque in drawer	*CH ID
24	∞ mode total	∞MODE	74	(+) Dept total	*DEPT TL
25	MGR ∞	MGR ∞	75	(-) Dept total	DEPT (-)
26	Subtotal ∞	SBTL ∞	76	Hash (+) total	*HASH TL
27	Hash ∞	HASH ∞	77	Hash (-) total	HASH (-)
28	Hash refund	HASH RF	78	Bottle return (+) total	*BTTL TL
29	VAT shift	VAT SFT	79	Bottle return (-) total	BTTL(-)
30	VAT/tax delete	TAX DELE	80	Net 1 (Taxable 1 - VAT/tax 1)	NET 1
31	VP counter	VP CNT	81	Net 2 (Taxable 2 - VAT/tax 2)	NET 2
32	No sale	NO SALE	82	Net 3 (Taxable 3 - VAT/tax 3)	NET 3
33	Guest check counter	G.C. CNT	83	Net (Taxable - VAT)	NET
36	RA	***RA	84	Subtotal	SUBTOTAL
37	RA2	***RA2	85	Merchandise subtotal	MDSE ST
38	PO	***PO	86	Total	***TOTAL
39	PO2	***PO2	87	Change	CHANGE
40	Cheque cashing	CA/CHK	88	Due	DUE
41	Cash	CASH	89	Sales q'ty	ITEMS
42	Cash 2	CASH2	90	PLU subtotal	PLU ST
43	Cheque 1	CHECK	91	Copy receipt title	COPY
44	Cheque 2	CHECK2	92	Guest check copy title	G.C COPY
45	Cheque 3	CHECK3	93	Average	AVE.
46	Cheque 4	CHECK4	94	Group 1 for departments	GROUP01
47	Credit 1	CREDIT1	95	Group 2 for departments	GROUP02
48	Credit 2	CREDIT2	96	Group 3 for departments	GROUP03
49	Credit 3	CREDIT3	97	Group 4 for departments	GROUP04
50	Credit 4	CREDIT4	98	Group 5 for departments	GROUP05

Function no.	Key or function	In default of programming
99	Group 6 for departments	GROUP06
100	Group 7 for departments	GROUP07
101	Group 8 for departments	GROUP08
102	Group 9 for departments	GROUP09
103	CCD	CCD
104	CCD differ	CCD DIF.
105	CCD differ total	DIF. TL
106	Order total - Paid total	O - P
107	Commission amount 1	COM.AMT1
108	Commission amount 2	COM.AMT2
109	Commission amount 3	COM.AMT3
110	Commission amount total	COM.TTL
111	Department report title	DEPT
112	Group report title	GROUP
113	PLU report title	PLU
114	PLU stock report title	STOCK
115	Transaction report title	TRANS.
116	Total in drawer report title	TL-ID
117	Commission sales report title	SALES
118	Cashier report title	CASHIER
119	Hourly report title	HOURLY
120	Daily net report title	DAILY
121	Set PLU	SET PLU
122	Total tax	TTL TAX
123	Net without tax	NET
124	PLU zero sales report title	ZERO SAL
125	Price category report title	CATEGORY
126	Difference subtotal	DIFF ST

9 Cashier programming

■ Cashier code PGM 1 PGM 2 1500

You can assign a cashier code to each of 4 cashiers. (If the cashier's file is upgraded, a maximum of 15 cashiers can be programmed. Consult your local dealer.)

Procedure

A guidance message is displayed each time you press the key.

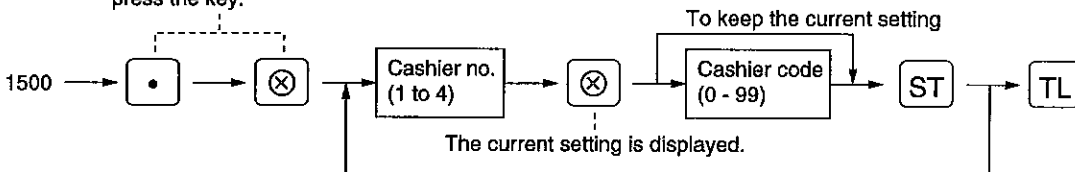

Example

Key operation

```

1500 [.] [X]
1 [X] 11 [ST]
4 [X] 14 [ST]
      [TL]
    
```

Print

```

#1500 *PGM2*
01CSR#           11
                  000001
04CSR#           14
                  000001
    
```

Cashier no. ————
Cashier code ————

■ Cashier name PGM 1 PGM 2 1514

You can program a maximum of 8 characters (cashier name) for each cashier. Refer to section "2 How to program alphanumeric characters" in chapter "PRIOR TO PROGRAMMING".

Procedure

A guidance message is displayed each time you press the key.

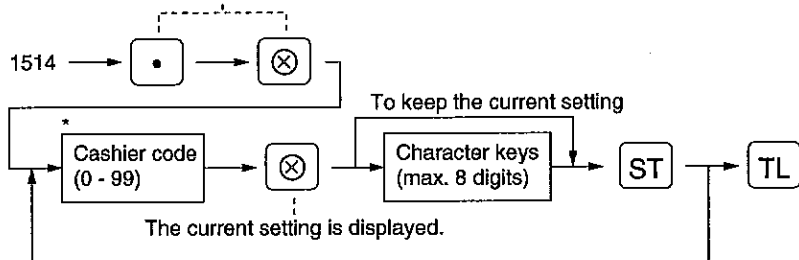

*: A code you have programmed for the cashier by job code 1500

Example

Key operation

1514 . (X)
 11 (X) MEYER (ST)
 (TL)

Print

```

#1514 *PGM2*

01CSR#          11
MEYER           000001
  
```

Procedure

A guidance message is displayed each time you press the key.

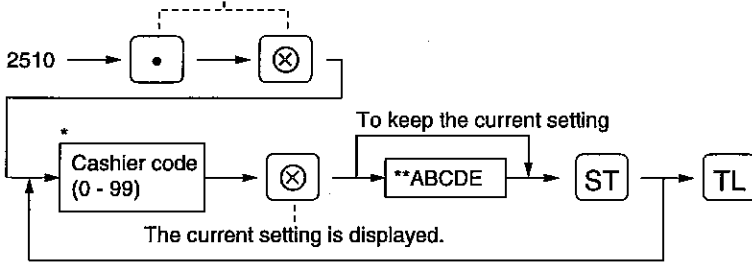

*: A code you have programmed into the cashier by job code 1500

** Item:	To:	Enter:
A	disable the guest check copy	1
	enable the guest check copy	0
B	enable VAT shift	1
	disable VAT shift	0
C	Always enter 0.	0
D	Always enter 0.	0
E	set the drawer no. 1 or 2	1 or 2
	do not use a drawer	0

Example

Key operation

2510 [.] [X]
 11 [0] 00001 [ST]
 [TL]

Print

```

#2510 *PGM2*

01CSR#           11
MEVER            000001
    
```

Drawer no.
A through D

■ Programming for optional feature selection PGM 2 2616**OP X/Z mode availability**

When a cashier needs to take the cashier X or Z report, he or she will use the OP X/Z mode. This programming determines whether he or she will be allowed to use this mode.

Note

You can take cashier X and Z reports in the X1/Z1 mode regardless of the above programming.

The availability of the REG-mode Paid-out operation

The availability of the REG-mode refund key depression

The availability of the REG-mode direct void

The availability of the REG-mode indirect void

The availability of the REG-mode subtotal void

The selection of compulsory or non-compulsory validation printing in a refund entry

The availability of the first item direct void

PLU level shift mode

This programming selects one of the two PLU level shift modes described below - "automatic return mode" and "lock shift mode".

Automatic return mode: This mode automatically shifts the PLU level back to level 1 (normal level) after a direct PLU key (item key) is depressed.

Lock shift mode: This mode holds the current PLU level until the next depression of a PLU level shift key.

The available mode switch position for PLU level shift

This programming determines whether to allow PLU level shift in both the REG and MGR modes or in the MGR mode alone.

The availability of the printing of the number of purchases**The journal print form**

You may choose either of the following forms.

- Detailed journal print that shows the details of all entries - the same information as printed on the receipt.
- Summary journal print that shows information about all entries other than normal department entries (entries into "+" departments and their associated "+" PLUs).

The availability of the item validation printing

The selection of compulsory or non-compulsory coupon validation printing

The selection of zero suppression for various reports

The selection of printing VAT/tax amount, taxable amount and net amount on the receipt/journal

The selection of PLU level shift type

The selection of VAT shift type

The selection of credit counting when Received-on-account/Paid-out is finalized with the credit key

The selection of the separator type on a report

Procedure

A guidance message is displayed each time you press the key.

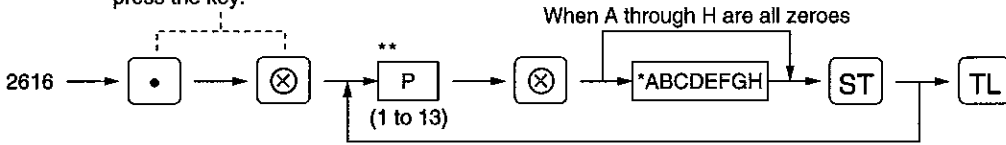

**P: 1

*

Item:	To:	Enter:
A OP X/Z mode availability	allow the use of this mode	0
	disallow it	1
B Paid-out in REG-mode availability	allow the Paid-out operation in REG-mode	0
	disallow it	1
C Always enter 0.	(Fixed position)	0
D Refund key availability	allow the REG-mode refund entry	0
	disallow it	1
E Direct void availability	allow the REG-mode direct void	0
	disallow it	1
F Indirect void availability	allow the REG-mode indirect void	0
	disallow it	1
G Subtotal void availability	allow the REG-mode subtotal void	0
	disallow it	1
H Refund validation print compulsory/non-compulsory	select non-compulsory	0
	select compulsory	1

**P: 2

*

Item:	To:	Enter:
A First item direct void availability	allow the first item direct void	0
	disallow it	1
B PLU level shift mode	select the automatic return mode	0
	select the lock shift mode	1
C Mode switch position for PLU level shift	allow PLU level shift in both the REG and MGR modes	0
	allow it in the MGR mode alone	1
D Number of purchases print availability	disallow the printing of the number of purchases	0
	allow it	1
E Always enter 0.	(Fixed position)	0
F Journal print form	select detailed journal	0
	select summary journal	1
G Item validation print availability	allow item validation printing	0
	disallow it	1
H Coupon validation print compulsory/non-compulsory	select non-compulsory	0
	select compulsory	1

**P: 3

*

Item:	To:	Enter:
A and B Always enter 0.	(Fixed position)	0
C Cashier report zero suppression selection	select zero suppression	0
	select non-skip printing	1
D Transaction report zero suppression selection	select zero suppression	0
	select non-skip printing	1
E Dept. report zero suppression selection	select zero suppression	0
	select non-skip printing	1
F PLU report zero suppression selection	select zero suppression	0
	select non-skip printing	1
G Hourly report zero suppression selection	select zero suppression	0
	select non-skip printing	1
H Daily net report zero suppression selection	select zero suppression	0
	select non-skip printing	1

**P: 4

*

Item:	To:	Enter:
A and B Always enter 0.	(Fixed position)	0
C VAT/tax amount printing on the receipt/journal	print	0
	do not print	1
D Taxable amount printing on the receipt/journal	print	0
	do not print	1
E Net amount printing on the receipt/journal	print	0
	do not print	1
F and G Always enter 0.	(Fixed position)	0
H PLU level shift type	return the PLU level to Level 1 each time a receipt is issued when the automatic return mode is selected	1
	return the PLU level to Level 1 each time an item is entered when the automatic return mode is selected	0

**P:5

*

Item:	To:	Enter:
A to C Always enter 0.	(Fixed position)	0
D VAT shift type	perform it by the operation of a cashier who has been assigned to do the VAT shift operation (Refer to job 2410)	0
	perform it by pressing the VAT shift key	1
E to H Always enter 0.	(Fixed position)	0

**P:6 to 12 (ABCDEFGH: Not used)

**P:13

*

Item:	To:	Enter:
A Credit counting when Received-on-account/Paid-out is finalized with the credit key	count	1
	do not count	0
B Separators on a report	use lines	1
	use separators	0
C to H Always enter 0.	(Fixed position)	0

Example

Key operation

2616 [•] [⊗]
 3 [⊗] 10 [ST]
 [TL]

Print

```
#2616 *P*GM2*
03
00000010
P: 1 through 13
A through H
```

■ Programming alarm length of time with drawer opening **PGM 2** **2617**

If the drawer still remains open when a specified length of time has elapsed, your machine gives the alarm.

Procedure

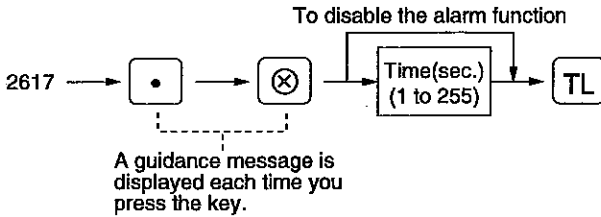

Example

Key operation

2617 [•] [⊗]
 30 [TL]

Print

```
#2617 *P*GM2*
030
```

Note

Your machine starts to monitor how long the drawer is kept open the moment the drawer is opened at the end of a transaction in the REG/VOID mode. It stops the time monitoring when a valid key (except the [VP] and [RCPT] keys) is pressed for the next transaction. It restarts the time monitoring after that transaction is ended. You can stop the buzzer alarm by closing the drawer. No key entries can be made while the buzzer is sounding.

■ Programming the limit on the number of times of validation printing and the number of feed lines after printing of a difference subtotal **PGM 2** **2615**

Procedure

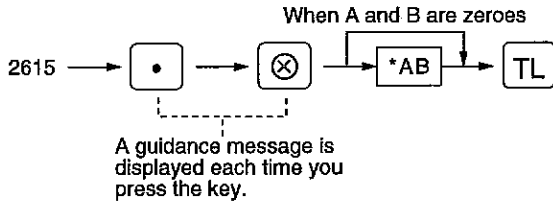

- * A: Validation printing counter (0 through 9 times)
To inhibit validation printing, enter 0.
- B: Feed lines after printing of a difference subtotal (0 through 9 lines)

Example

Key operation	Print
2615 [.] [⊗] 10 [TL]	#2615 *PGM2* 10

■ Programming of logo text PGM 2 2614

Your machine can print messages in the following five manners. The standard model provides no message line; it allows stamping only. If you need the printing of programmed messages, please consult your dealer.

- (1) No logo message printed (logo stamp only)
- (2) 3-line logo message (header) instead of logo stamp
- (3) 3-line logo message (footer) and logo stamp
- (4) 6-line logo message (header) instead of logo stamp
- (5) 3-line logo message (header) and 3-line logo message (footer)

Print positions on the receipt

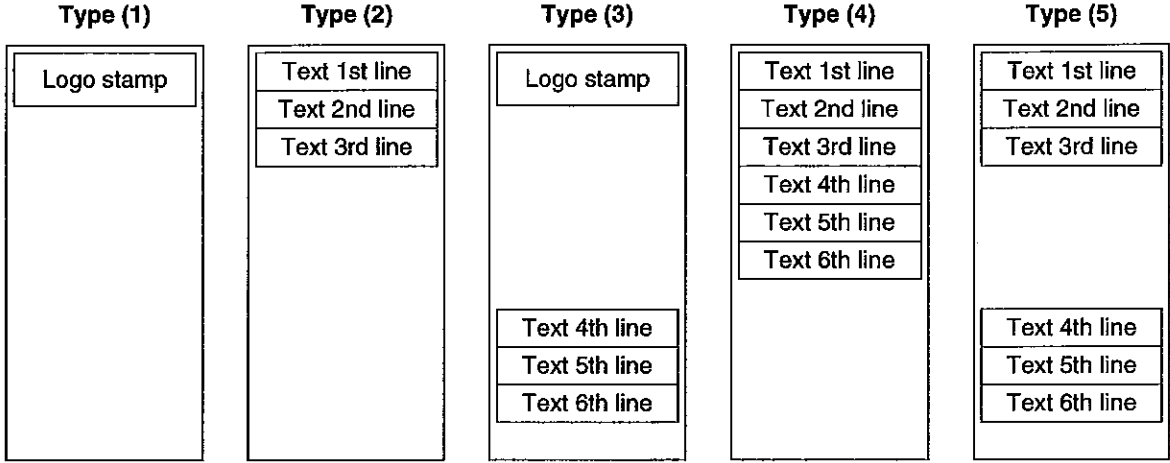

Note Up to 24 characters can be programmed per line.
Your register can print programmed messages for customers on every receipt.

Procedure

A guidance message is displayed each time you press the key.

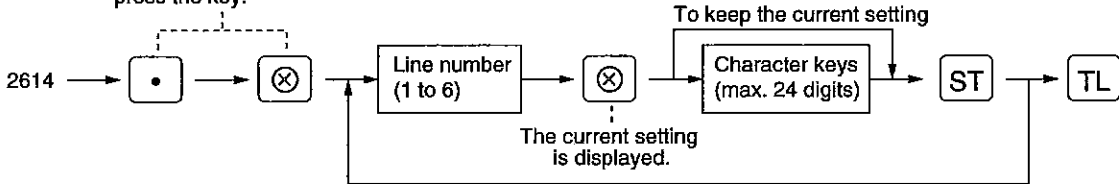

Example

Programming the logo message "****MESSAGE****" (Assuming you are in type 3)

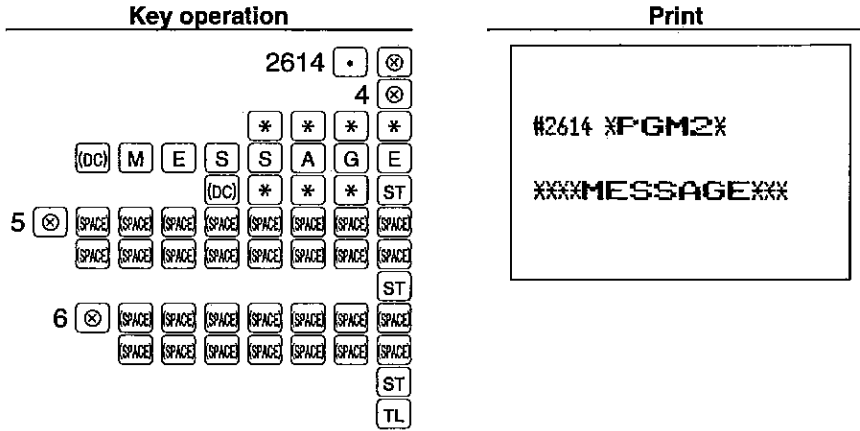

Sample printout of the logo message on the receipt

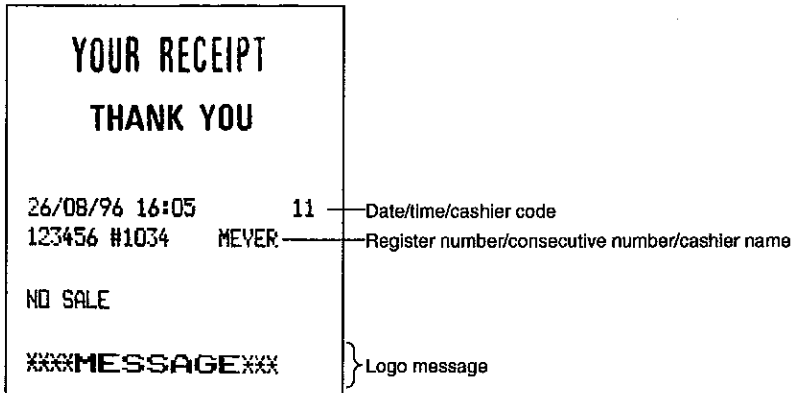

■ Programming of guidance messages PGM 2 2644

Your register has standard guidance messages as listed in the table below. If you want to change the guidance messages, the optional RAM memory chip is needed. Contact your local dealer. For more information about the alphanumeric characters programming, see section "2 How to program alphanumeric characters" under the chapter "PRIOR TO PROGRAMMING".

Procedure

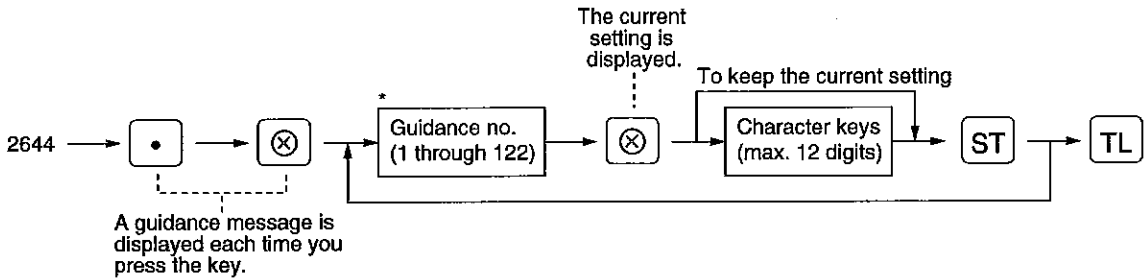

Guidance no.	Default setting	Contents of programming	Reference job no.
1	DEPT PRICE	Department unit price	#1110
2	DEPT FUNC.	Department function	#2110
3	DEPT TAXABLE	Department tax status	#2111
4	DEPT HALO	Department HALO	#2112
5	DEPT TEXT	Department text	#2114
6	DEPT COM.GRP	Department commission group	#2115
7	DEPT GROUP	Department group	#2116
8	DEPT DRCTKEY	Department direct key	#2119
9	PLU ASG.DEPT	Associate department for PLUs	#1200
10	PLU PRICE	PLU unit price	#1210
11	PLU-BASE QTY	PLU base quantity	#1211
12	PLU STCK ADD	PLU stock addition	#1220
13	PLU STCK SUB	PLU stock subtracting	#1221
14	PLU STCK OVW	PLU stock overwrite	#1222
15	PLU FUNCTION	PLU function	#2210
16	PLU TAXABLE	PLU tax status	#2211
17	PLU TEXT	PLU text	#2214
18	PLU COM.GRP	PLU commission group	#2215
19	PLU DRCT KEY	PLU direct key	#2219
20	LINK PLU	Link PLU	#2220
21	SET PLU	Set PLU	#2221
22	PLU CODE RNG	PLU code (for range of PLU)	#2230
23	PLU FUNC RNG	PLU function (for range of PLU)	#2231
24	PLU STTS RNG	PLU tax status (for range of PLU)	#2232
25	PLU COM.RNG	PLU commission group (for range of PLU)	#2235
26	RATE PRGRAM	Rate for % and EX keys and commission and discount for \ominus keys	#1310
27	MISC KEY PGM	Sign for miscellaneous keys	#2311
28	FNC KEY HALO	HALO for \ominus , RA, PO keys	#2312
29	MDIAKEY HALO	HALO for media keys	#2322
30	% HALO	HALO for % keys	#2313
31	FUNC TEXT	Alphanumeric characters for functions	#2314
32	MISC KEY PGM	% item or % subtotal	#2315
33	MISC KEY PGM	\ominus item or \ominus subtotal	#2316
34	MDIA KEY PGM	Functions for media keys	#2320
35	MDIAKEY HALO	HALO for cheque cashing, cash in drawer and cheque change	#2321
36	CSR CODE PGM	Cashier code	#1500

Guidance no.	Default setting	Contents of programming	Reference Job no.
37	CSR NAME PGM	Cashier name	#1514
38	CSR PGM	Functions to cashiers	#2510
39	DATE PROGRAM	Date	#2610
40	TIME PROGRAM	Time	#2611
41	MCHN NO. PGM	Register number	#2612
42	CC NO. PGM	Consecutive number	#2613
43	LOGOTEXT PGM	Message text	#2614
44	VP COUNT	Number of validation printing	#2615
45	OPT FEATURE	Optional feature selection	#2616
46	DRAWER ALARM	Alarm length of time with drawer opening	#2617
47	HOURLYREPORT	Hourly report	#2619
48	STACK REPORT	Stacked report	#2620
49	SECRET(PGM1)	Secret code (PGM1 mode)	#2630
50	SECRET(X1Z1)	Secret code (X1/Z1 mode)	#2631
51	SECRET(X2Z2)	Secret code (X2/Z2 mode)	#2632
52	MESSGE TEXT	Error message	#2641
53	GUID TEXT	Guidance message	#2644
54	TAX RATE	Tax rate	#2711
55	PRICE	Setting a unit price	#1110, #1210
56	ENTER DEPT#	Entering a department code	#1200, #2230
57	SIGN (-)	- sign setting	#2111-A, #2211-A, #2311-A,
58	SIGN (+)	+ sign setting	#2232-A
59	TAXABLE1:YES	Taxable 1 "Yes"	#2111-F, #2211-F, #2311-F,
60	TAXABLE1:NO	Taxable 1 "No"	#2232-F
61	TAXABLE2:YES	Taxable 2 "Yes"	#2111-E, #2211-E, #2311-E,
62	TAXABLE2:NO	Taxable 2 "No"	#2232-E
63	TAXABLE3:YES	Taxable 3 "Yes"	#2111-D, #2211-D, #2311-D,
64	TAXABLE3:NO	Taxable 3 "No"	#2232-D
65	VAT:YES	VAT "Yes"	#2111-C, #2211-C, #2311-C,
66	VAT:NO	VAT "No"	#2232-C
67	PRT CSR:YES	Printing on the cashier report "Yes"	#2110-A
68	PRT CSR:NO	Printing on the cashier report "No"	
69	VP COMPL:YES	Validation print compulsory	#2110-B, #2320-E
70	VP COMPL:NO	Validation print non-compulsory	
71	SIF	SIF for departments	#2110-E
72	SICS	SICS for departments	
73	NORMAL	Normal (neither SIF nor SICS) for departments	
74	DELETE	Delete mode for PLUs	#2210-C, #2231-C
75	OPEN&PREST	Open & preset price entry for dept./ PLU/subdept. mode for PLUs	#2110-G, #2210-C, #2231-C
76	PRESET	Preset price entry for dept./PLU mode for PLUs	
77	OPEN	Open price entry for dept./Subdepartment mode for PLUs	
78	INHIBITED	Inhibit dept./PLU/subdept.	
79	HALO(EXP.)	HALO	#2112, #2312, #2322
80	HALO(AMOUNT)	HALO (amount for cheque cashing, cash in drawer and cheque change)	#2321
81	HALO(RATE)	HALO (rate for % keys)	#2313
82	COM.GRP	Commission group	#2115, #2215, #2235
83	GROUP	Group number	#2116
84	BASE Q'TY	Base quantity	#2118
85	STOCK(ADD)	PLU stock addition	#1220
86	STOCK(SUB)	PLU stock subtracting	#1221
87	STOCK(OVER)	PLU stock overwrite	#1222
88	RATE	Rate and the discount	#1310
89	ITEM	Item	#2315, #2316
90	ST	Subtotal	
91	EFT CMPL	EFT compulsory	#2320-A
92	EFT NONCMPL	EFT noncompulsory	

Guidance no.	Default setting	Contents of programming	Reference Job no.
93	FOOTER :YES	Footer printing "Yes"	#2320-B
94	FOOTER :NO	Footer printing "No"	
95	# CMPL	Non-add code compulsory	#2320-C
96	# NONCMPL	Non-add code non-compulsory	
97	DUE DISABLE	Change disable	#2320-D
98	DUE ENABLE	Change enable	
99	DRW OPEN:YES	Opening the drawer "Yes"	#2320-J
100	DRW OPEN:NO	Opening the drawer "No"	
101	TND CMPL:YES	Compulsory amount tendered	#2320-K
102	TND CMPL:NO	Optional amount tendered	
103	TND INH.	Inhibit amount tendered	
104	ENTER PLU#	Entering a PLU code	#2220, #2221
105	ENT.CSR CODE	Entering a cashier code	#1500
106	ENT.CSR NO	Entering a cashier number	
107	ENT.DRW#	Entering a drawer number for a cashier	#2510-E
108	G.C COPY YES	Enabling guest check copy	#2510-A
109	G.C COPY NO	Disabling guest check copy	
110	VAT SFT STAT	VAT shift status	#2510-B
111	VAT SFT NOT	The state is not VAT shift status	
112	ENT.DEPT#	Entering a department code	#1110, #2110, #2111, #2112, #2114, #2116
113	ENT.KEY#	Entering a key number	#2119, #2219
114	ENT.FUNC#	Entering a function number	#1310, #2311, #2312, #2322, #2313, #2314, #2315, #2316, #2320, #2321
115	ENT.POS.CODE	Entering a line number for a logo text	#2614
116	ENTER TAX NO	Entering a tax number	#2711
117	ENT.TAX RATE	Entering a tax rate	
118	LOWER TAX	Entering a lowest taxable amount	
119	ENTER MSG NO	Entering a message number	#2641
120	ENTER GID NO	Entering a guidance number	#2644
121	(FIXED DATA)	The message for "Fixed" or "Not used" data	
122	ENTER [00] KEY	The message to go to the character entry mode at EASY PROGRAMMING mode	

Example

Key operation

2644 • ⊗
 1 ⊗
 D E P T SPACE
 P R I C E
 ST
 TL

Print

```
#2644 *PGM2*
001      DEPT PRICE
```

■ Programming of error message PGM 2 2641

Your register has standard error messages as listed on the next page. If you want to change the error messages, the optional RAM memory chip is needed. Contact your local dealer. For more information about the alphanumeric characters programming, see section "2 How to program alphanumeric characters" under the chapter "PRIOR TO PROGRAMMING".

Procedure

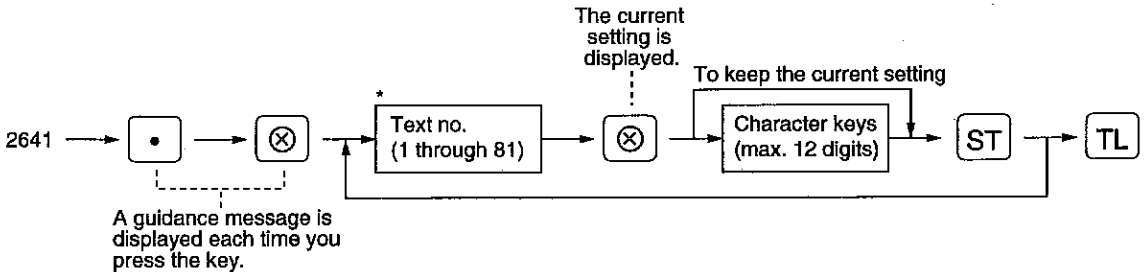

* Text no.: See "LIST OF ERROR MESSAGES" shown on the next page.

Example

Key operation

2641 • ⊗
 1 ⊗
 E N T R Y SPACE
 E R R O R
 ST
 TL

Print

```
#2641 *PGM2*
01      ENTRY ERROR
```

LIST OF ERROR MESSAGES

TEXT NO.	STATE	DEFAULT SETTINGS
1	Registration error	ENTRY ERROR
2	Misoperation error	MISOPERATION
3	Desired code is not programmed yet.	NO RECORD
4	The journal paper roll comes near the end or is not loaded.	PAPER EMPTY
5	Secret code error	SECRET CODE
6	(Reserved)	
7	Memory is full.	MEMORY FULL
8 to 9	(Reserved)	
10	The stock is zero or negative.	OUT OF STOCK
11	Compulsory pushing the subtotal key	SBTL COMPUL.
12	Compulsory tendering	TEND COMPUL.
13 to 18	(Reserved)	
19	(Reserved)	
20 to 21	(Reserved)	
22	Overlapped cashier error	CASHIER ERR.
23	Cashier entry error	ENTRY ERR. CA
24 to 30	(Reserved)	
31	Compulsory non-add code entry	# COMPULSORY
32	The cashier code is not assigned.	NOT ASSIGNED
33	The cashier code is changed in the transaction.	NOT CHANGE
34	Overflow limitation	OVER LIMIT.
35	The open price entry is inhibited.	INH. OPEN PR
36	The unit price entry is inhibited.	INH. UNIT PR
37	The direct non-tendering finalization after previous tender entry is inhibited.	NOT NON-TEND
38	(Reserved)	
39	Power off during validation printing	P_OFF IN VP
40 to 66	(Reserved)	
67	REG Buffer is full.	BUFFER FULL
68 to 71	(Reserved)	
72	EFT error	EFT ERROR
73	EFT connection is broken	EFT BREAK
74 to 75	(Reserved)	
76	Closing the drawer is compulsory.	CLOSE DRAWER
77 to 80	(Reserved)	
81	Message for prompting entry of secret code	ENTR SECRET#

■ Selection of X1/Z1 and X2/Z2 reports to be printed in the stacked report sequence

PGM 2 2620

Your register is equipped with the stacked report printing function that enables multiple X/Z reports to be printed in sequence with only a single request, up to maximum of 13 reports*. This function continuously prints a maximum of 13 kinds of reports with a single operation.

Procedure

A guidance message is displayed each time you press the key.

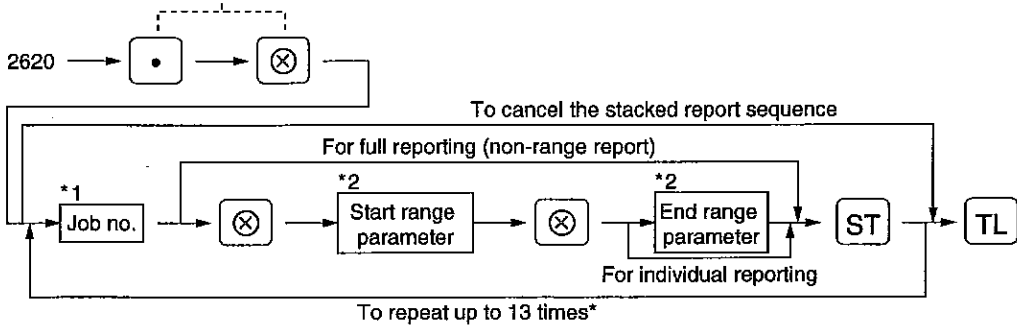

*: Maximum 70 steps are programmable. "1 step" means the memory size used for one no-range type job no. The range type job no. needs "8 steps".

Job code numbers to be used are as follows.

*1

*2

Job no.	Report	Available report	Range parameter
00	General report		
10	Full department report	X1/X2 report only	
13	Full department group report	X1/X2 report only	
20	PLU report		*3 Start PLU code/end PLU code (1 through 999999)
24	PLU stock report	X1/X2 report only	*3 Start PLU code/end PLU code (1 through 999999)
27	PLU zero sales report	X1/X2 report only	*3 Start PLU code/end PLU code (1 through 999999)
29	PLU price category report	X1/X2 report only	*3 Start price amount/end price amount
30	Transaction report	X1/X2 report only	
31	Cash in drawer report	X1/X2 report only	
32	Commission sales report	X1/X2 report only	
50	Full cashier report		
60	Hourly sales information	Range report is available only in the X1/X2 report.	*3 Start time/end time (0 through 2345)
70	Daily net report	X2/Z2 report only	

*3: Both range setting and full setting are allowed.

Note When Z of stacked report is initiated, X only reports will be skipped.

Example

Key operation

2620 [•] [⊗]
 10 [ST]
 13 [ST]
 [TL]

Print

```
#2620 XPGM2%
                                     10
                                     13
```

■ Secret codes to control access to PGM1 mode, X1/Z1 mode and X2/Z2 mode

PGM 2 2630 2631 2632

- When changing stored programs in the PGM1 mode, those operations are inhibited if no secret code is entered.
- If a secret code has not been entered yet, any X1/Z1 mode or X2/Z2 mode operation cannot be performed.
- You must enter a secret code according to the following procedure before performing any PGM1 mode, X1/Z1 mode or X2/Z2 mode operation.

Operation

Procedure

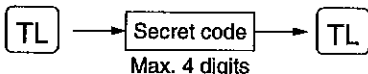

Note

Once a secret code is entered, it does not need to be entered again unless the mode switch setting is changed and any operation, such as a sales registration, reporting, or programming, is performed.

Programming

Procedure

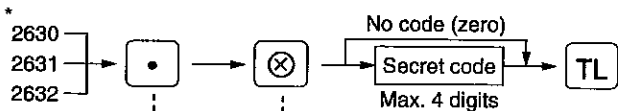

A guidance message is displayed each time you press the key.

- * 2630 for the PGM1 mode
- 2631 for the X1/Z1 mode
- 2632 for the X2/Z2 mode

Example

Key operation

2631
1234 TL

Print

#2631 XPGM2X

1234

■ Setting the time range for hourly report PGM 2 2619

You can set the time range for an hourly report.

Procedure

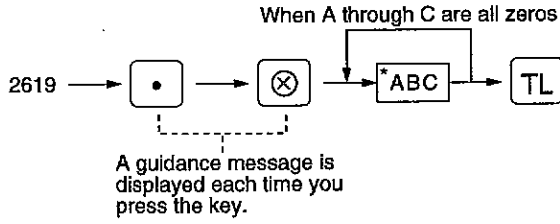

*A: Time range

To set the time range to 30 minutes (in the 24-hour system), enter 0.

To set the time range to 15 minutes (in the 12-hour system), enter 1.

BC: Starting time (hour = 00 to 23)

Example

Key operation	Print
2619 . ⊗ 107 TL	<pre>#2619 *PGM2* 1 07</pre>

Note To perform this setting, an hourly Z report (#160) must be done.

■ Programming of AUTO keys X2/Z2 2900

If you program frequently performed transactions for the AUTO keys, you can enter those transactions simply by pressing the corresponding AUTO keys in key operations. This programming can be done when your machine is in the X2/Z2 mode.

Procedure

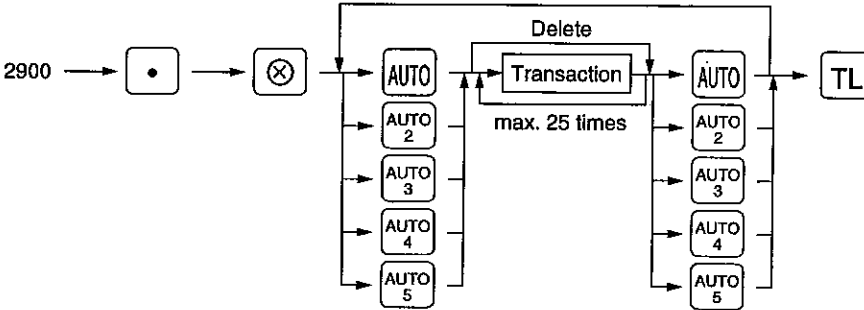

Example

Programming for AUTO key and AUTO key as follows:

AUTO: entering a PLU 2 item (unit price:1.50) and a dept. 6 item (unit price:1.00)

AUTO: selling a dept. 7 item (programmed unit price:5.00) for cash

Key operation	Print
<div style="display: flex; justify-content: space-between; align-items: flex-start;"> <div style="width: 40%;"> <p>2900 . ⊗</p> <p>AUTO1 → 2 PLU/SUB 100 6</p> <p>AUTO2 setting → 7 TL</p> </div> <div style="width: 50%; text-align: center;"> AUTO AUTO AUTO AUTO TL AUTO TL </div> </div>	<div style="border: 1px solid black; padding: 10px; min-height: 200px;"> <pre>#2900 *P*GM2* #01 2 KEY PLU 1 KEY 0 KEY 0 KEY L1 D06 #02 L1 D07 TOTAL</pre> </div>

11 TRAINING mode

The training mode is used when the operator or the manager practices register operations.

When a cashier set in training is selected, the machine automatically enters the training mode. When a cashier not set in training is selected, the machine automatically enters the ordinary REG mode. (For programming of training cashier, consult your local dealer.)

The training operations is valid only in REG, MGR, and VOID mode.

The memory in cashier is updated in the training mode. Other memories are not updated.

Key operation	Print
Selecting the cashier set in training	26/08/96 19:32 12
1000 <input type="button" value="6"/>	123456 #1187
3 <input type="button" value="⊗"/>	
<input type="button" value="7"/>	
<input type="button" value="TL"/>	
	TRAINING
	DPT.06 ¥10.00
	3x 5.00
	DPT.07 ¥15.00
	CASH ¥25.00

12 Reading stored programs

Your machine allows you to read every program stored in the PGM1 and PGM2 modes.

Program details and procedures for their reading

Program for:		Mode switch position	Job code no.	Procedure	Related job code nos.
1	Departments	PGM2 or PGM1	1100		1110, 2110, 2111, 2112, 2114, 2116
2	PLUs/ subdepartments	PGM2 or PGM1	1200		1200, 1210, 1211, 1220, 1221, 1222, 2210, 2211, 2214, 2215, 2220, 2221, 2230, 2232
3	Key nos. for departments and PLUs	PGM2	2119		2119, 2219
4	Link PLUs	PGM2	2220		2220
5	Set PLUs	PGM2	2221		2221
6	Cashiers	PGM2 or PGM1	1500		1500, 1514, 2510
7	Function preset	PGM2 or PGM1	1300		1310, 2311, 2312, 2313, 2314, 2315, 2316, 2320, 2321, 2322
8	Miscellaneous presets	PGM2	2600		2614, 2615, 2616, 2617, 2619, 2620, 2630, 2631, 2632
9	Messages	PGM2	2640		2641, 2644
10	Tax rates	PGM2	2700		2711
11	Auto keys	PGM2	2900		2900

■ Sample printouts

1 Reading of programmed items for departments (Reading in the PGM1 and PGM2 modes)

26/08/96 18:19 123456 #1117		Mode lock position*	
Job code no.	#1100 #PGM2%		
Dept. code	D01	01-12	
Item label	STEAK	10.00	Unit price
	0000003	G01	Group no.
	D02	C1L95	HALO limit.
	DPT.02	5.00	Commission group
	0000003	G02	
	D03	COL17	
	DPT.03	0.00	
	0000003	G01	
	D04 T1 3	COL17	Function programming
Tax status	DPT.04	0.00	0 0 0 0 0 3
	0000001	G01	Type of unit price entry
		COL17	SIF/SICS/Normal
	D11	0.00	Item validation print compulsory/non-compulsory
	DPT.11	G01	Printing on the cashier report
	0000001	COL17	
	D12	-1.00	Minus department
	DPT.12	G10	
	0000003	COL17	

2 Reading of programmed items for PLUs/subdepartments (Reading in the PGM1 and PGM2 modes)

26/08/96 18:21 123456 #1118		Mode lock position*	
#1200 #PGM2%			
PLU code	000001-000020	Associate dept. code	
	F000001(O2)	/00	
Item label	T1	1.25	Unit price
	MILK	C1	Commission group
	003	S 20.000	Tax status
	F000002(O2)	/12	Stock
		0.00	Base q'ty
	PL000002	C0	
	002	S 12.500	Mode param
	F000003(O1)	/00	0 0 2
		1.50	
	PL000003	C0	
	002	S 18.000	
	F000004(O1)	/00	
	T 2	0.00	
	PL000004	C1	
	002	S 0.000	
F000018(O3) L		/00	Link PLU
	T1	0.00	
	PL000018	C0	
	003	S 0.000	
	F000019(O3)	/00	
	T1	-1.50	
	PL000019	C0	
	003	S 0.000	Set PLU
	F000020(O3) S	/00	
	T1	0.00	
	PL000020	C0	
	003	S 0.000	

* When you take this report in the PGM1 mode, the PGM2 indication is replaced by a "PGM1".

**3 Reading of programmed key nos. for departments and PLUs
(Reading in the PGM2 mode)**

```

26/08/96 18:24
123456 #1119

#2119 *PGM2*

001 L1 F000001
      L2 F000065
      L3 F000129
002 L1 F000002
      L2 F000066
      L3 F000130
003 L1 F000003
      L2 F000067
      L3 F000131
004 L1 F000004
      L2 F000068
      L3 F000132
  
```

Key no.
PLU code
PLU level

```

101 L1 D01
102 L1 D02
103 L1 D03
104 L1 D04
105 L1 D05
106 L1 D06
107 L1 D07
108 L1 D08
109 L1 D09
110 L1 D10
111 L1 D11
112 L1 D12
  
```

Dept. code

```

113 L1 ---
      L2 ---
      L3 ---
119 L1 ---
      L2 ---
      L3 ---
120 L1 ---
      L2 ---
      L3 ---
  
```

**4 Reading of programmed link PLUs
(Reading in the PGM2 mode)**

```

26/08/96 18:27
123456 #1120

#2220 *PGM2*

000020-000030
F000021 LP000025
          P000026
          P000027
F000022 LP000028
          P000029
  
```

**5 Reading of programmed set PLUs
(Reading in the PGM2 mode)**

```

26/08/96 18:28
123456 #1121

#2221 *PGM2*

000001-999999
F000020 SP000201
          F000202
F000178 SP000179
          F000180
  
```

**6 Reading of programmed items for cashiers
(Reading in the PGM1 and PGM2 modes)**

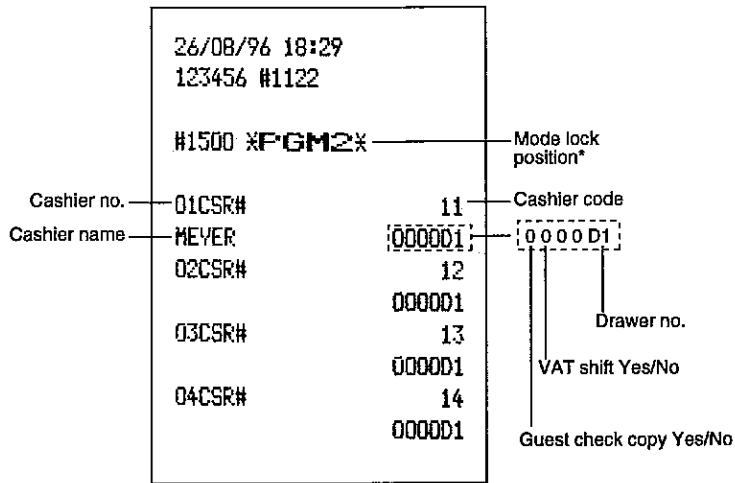

* When you take this report in the PGM1 mode, the PGM2 indication is replaced by a "PGM1".

7 Reading of programmed items for functions
(Reading in the PGM1 and PGM2 modes)

26/08/96 18:30		
123456 #1123		
#1300 *PGM2*	Mode lock position*	
F001 (-) 1		
I	-10.00	
	L13	
F002 (-) 2		
S	-0.00	
	L17	
F003 (-) 3		
S	-0.00	
	L17	
F004 (-) 4		
S	-0.00	
	L17	
F005 %1		
I	10.25%	
	L 15.00%	
F006 %2		
S	-15.00%	
	L100.00%	
F007 %3		
S	-0.00%	
	L100.00%	
F008 %4		
S	-0.00%	
	L100.00%	
F009 SET PLU-		
F010 DIFFER		
F011 TAX1 ST		
F012 TAX2 ST		
F013 TAX3 ST		
F014 TAX ST		
F015 VAT 1		
F016 VAT 2		
F017 VAT 3		
F018 VAT		
F019 NET1		
F020 NET2		
F021 CP PLU		
F022 REFUND		
F023 ↵		
F024 Ⓜ MODE		
F025 MGR Ⓜ		
F026 SBTL Ⓜ		
F027 HASH Ⓜ		
F028 HASH RF		
F029 VAT SFT		
F030 TAX DELE		
F031 VP CNT		
F032 NO SALE		
F033 G.C. CNT		
F036 XXXRA	L18	
F037 XXXRA2	L18	
F038 XXXPD	L18	
F039 XXXPD2	L18	
F040 CA/CHK		
	99.99	
F041 CASH	L18	
	0000000000	
F042 CASH2	L18	
	0000000000	
F043 CHECK	L18	
	0000000000	
F044 CHECK2	L18	
	0000000000	
F045 CHECK3	L18	
	0000000000	
F046 CHECK4	L18	
	0000000000	
F047 CREDIT1	L18	
	0000000000	
F048 CREDIT2	L18	
	0000000000	
F049 CREDIT3	L15	
	00000000001	
F050 CREDIT4	L18	
	00000000000	
F051 EXCH1		
	0.6068	
F052 EXCH2		
	0.0000	
F053 EXCH3		
	0.0000	
F054 EXCH4		
F055 EXCH1 IS		
F056 EXCH2 IS		
F057 EXCH3 IS		
F058 XXXCID		
	9999999.99	

To be continued on the next page

* When you take this report in the PGM1 mode, the PGM2 indication is replaced by a "PGM1".

F059 CA/CH IS
 F060 CA/CH ID
 F061 CHK/CG
 999999.99
 F062 GUEST
 F063 COM.SAL1
 0.00%
 F064 COM.SAL2
 0.00%
 F065 COM.SAL3
 0.00%
 F066 NON COM.
 F067 ORDER TL
 F068 PAID TL
 F069 DOM.CUR1
 F070 DOM.CUR2
 F071 DOM.CUR3
 F072 DOM.CUR4
 F073 XCH ID
 F074 XDEPT TL
 F075 DEPT(-)
 F076 XHASH TL
 F077 HASH(-)
 F078 XBTTL TL
 F079 BTTL(-)
 F080 NET 1
 F081 NET 2
 F082 NET 3
 F083 NET
 F084 SUBTOTAL
 F085 MOSE ST
 F086 XXXTOTAL
 F087 CHANGE
 F088 DUE
 F089 ITEMS
 F090 PLU ST
 F091 **COPY**
 F092 G.C COPY
 F093 AVE.
 F094 GROUP01
 F095 GROUP02
 F096 GROUP03
 F097 GROUP04
 F098 GROUP05
 F099 GROUP06
 F100 GROUP07
 F101 GROUP08
 F102 GROUP09
 F103 **CCD**
 F104 CCD DIF.
 F105 DIF. TL

F106 **D-P**
 F107 COM.AMT1
 F108 COM.AMT2
 F109 COM.AMT3
 F110 COM.TTL
 F111 **DEPT**
 F112 GROUP
 F113 **PLU**
 F114 STOCK
 F115 TRANS.
 F116 TL-ID
 F117 SALES
 F118 CASHIER
 F119 HOURLY
 F120 DAILY
 F121 SET PLU
 F122 TTL TAK
 F123 **NET**
 F124 ZERO SAL
 F125 CATEGORY
 F126 DIFF ST

**8 Reading of miscellaneous preset
(Reading in the PGM2 mode)**

```

26/08/96 18:36
123456 #1125

#2600 *PGM2*

#2614 ----- Logo message
****MESSAGE****

#2615          10 ----- Line feed for Differ ST
#2616          1 ----- Validation printing counter
01          00000000
02          00000000
03          00000010
04          00000000
05          00000000
06          00000000
07          00000000 } Optional feature selection
08          00000000
09          00000000
10          00000000
11          00000000
12          00000000
13          00000000
#2617          030 ----- Drawer open alarm time
#2619          1 07 ----- Hourly report format
#2620                                     /start hour
                                     10 } Stacked report
                                     13 }
#2630          0000 } Secret code
#2631          1234 }
#2632          0000 }
    
```

**9 Reading of programmed messages
(Reading in the PGM2 mode)**

```

26/08/96 18:37
123456 #1126

#2640 *PGM2*

#2641 ----- Error messages
01          ENTRY ERROR
02          MISOPERATION
03          NO RECORD
04          PAPER EMPTY
05          SECRET CODE
06
07          MEMORY FULL
08
09
10          OUT OF STOCK
11          SE-TL COMPUL.
12          TEND COMPUL.
13
14
15
16
17
18
19
20
21
22          CASHIER ERR.
23          ENTRY ERR CA
24
25
26
27
28
29
30
31          # COMPULSORY
32          NOT ASSIGNED
33          NOT CHANGE
34          OVER LIMIT.
35          INH. OPEN PR
36          INH. UNIT PR
37          NOT NON-TEND
38
39          P_OFF IN VP
40
    
```

To be continued on the next page

41
42
43
44
45
46
47
48
49
50
51
52
53
54
55
56
57
58
59
60
61
62
63
64
65
66
67 BUFFER FULL
68
69
70
71
72 EFT ERROR
73 EFT BREAK
74
75
76 CLOSE DRAWER
77
78
79
80
81 ENTR SECRET#
82 SEND
83 RECEIVE
84 SEND OK
85 RECEIVE OK
86 COM. ERROR
87 DATA ERROR

88 TIME OUT
89 CANCEL
#2644
001 DEPT PRICE
002 DEPT FUNC.
003 DEPT TAXABLE
004 DEPT HALD
005 DEPT TEXT
006 DEPT COM.GRP
007 DEPT GROUP
008 DEPT DRCTKEY
009 PLU ASG.DEPT
010 PLU PRICE
011 PLU BASE QTY
012 PLU STCK ADD
013 PLU STCK SUB
014 PLU STCK DIV
015 PLU FUNCTION
016 PLU TAXABLE
017 PLU TEXT
018 PLU COM.GRP
019 PLU DRCT KEY
020 LINK PLU
021 SET PLU
022 PLU CODE RNG
023 PLU FUNC RNG
024 PLU STTS RNG
025 PLU COM RNG
026 RATE PROGRAM
027 MISC KEY PGM
028 FNC KEY HALD
029 MDIAKEY HALD
030 % HALD
031 FUNC TEXT
032 MISC KEY PGM
033 MISC KEY PGM
034 MDIA KEY PGM
035 MDIAKEY HALD
036 CSR CODE PGM
037 CSR NAME PGM
038 CSR PGM
039 DATE PROGRAM
040 TIME PROGRAM
041 MCHN NO. PGM
042 CC NO. PGM
043 LOGOTEXT PGM
044 VP COUNT
045 OPT FEATURE

046 DRAWER ALARM
047 HOURLYREPORT
048 STACK REPORT
049 SECRET (PGM1)
050 SECRET (X1Z1)
051 SECRET (X2Z2)
052 MESSGE TEXT
053 GUID TEXT
054 TAX RATE
055 PRICE
056 ENTER DEPTH
057 SIGN (-)
058 SIGN (+)
059 TAXABLE1:YES
060 TAXABLE1:NO
061 TAXABLE2:YES
062 TAXABLE2:NO
063 TAXABLE3:YES
064 TAXABLE3:NO
065 VAT:YES
066 VAT:NO
067 PRT CSR:YES
068 PRT CSR:NO
069 VP COMPL:YES
070 VP COMPL:NO
071 SIF
072 SICS
073 NORMAL
074 DELETE
075 OPEN&PREST
076 PRESET
077 OPEN
078 INHIBITED
079 HALD(EXP.)
080 HALD(AMOUNT)
081 HALD(RATE)
082 COM.GRP
083 GROUP
084 BASE Q'TY
085 STOCK(ADD)
086 STOCK(SUB)
087 STOCK(OVER)
088 RATE
089 ITEM
090 ST
091 EFT CMPL
092 EFT NONCMPL

To be continued on the next page

```

093      FOOTER :YES
094      FOOTER :NO
095      # CMPL
096      # NONCMPL
097      DUE DISABLE
098      DUE ENABLE
099      DRW OPEN:YES
100      DRW OPEN:NO
101      TND CMPL:YES
102      TND CMPL:NO
103      TND INH.
104      ENTER PLU#
105      ENT.CSR CODE
106      ENT.CSR NO
107      ENT.DRW#
108      G.C COPY YES
109      G.C COPY NO
110      VAT SFT STAT
111      VAT SFT NOT
112      ENT.DEPTH#
113      ENT.KEY#
114      ENT.FUNCH
115      ENT.POS.CODE
116      ENTER TAX NO
117      ENT.TAX RATE
118      LOWER TAX
119      ENTER MSG NO
120      ENTER GID NO
121      (FIXED DATA)
122      ENTERCOOKEY
123      DATA SEND
124      DATA RCV.
125      DRG*ZER RCV.
126      DNL T.NO.
127      DNL MODEM
128      DNL BAUDRATE
129      DNL CODE
130      DNL TIMER

```

**10 Reading of programmed tax rates
(Reading in the PGM2 mode)**

```

26/08/96 18:40
123456 #1127

#2700 *PGM2*

TAX1      3.0000%
           0.10
TAX2      4.0000%
           0.12
TAX3      4.0000%
           0.15

```

— Tax rate
— Lowest taxable amount

**11 Reading of programmed items for auto keys
(Reading in the PGM2 mode)**

```

26/08/96 18:40
123456 #1128

#2900 *PGM2*

#01
           2 KEY
           PLU
           1 KEY
           0 KEY
           0 KEY
           L1      D06
#02
           L1      D07
           TOTAL
#03
           ---
#04
           ---
#05
           ---

```

READING (X) AND RESETTING (Z) OF SALES TOTALS

- Use the reading function (X) when you need to take a reading of sales information entered since the last resetting. You can take this reading any number of times. It does not affect the register's memory.
- Use the resetting function (Z) when you need to clear the register's memory. Resetting prints all sales information and clears the entire memory except for the GT1 through GT3, reset count, and consecutive number.

1 Summary of reading (X) and resetting (Z) reports and the key operations to obtain the reports

X1 and Z1 reports: Daily sales reports

X2 and Z2 reports: Periodic (monthly) consolidation reports

Flash reports:

To display the total amount without printing out the report, do the following:

To clear the display
 → *A key → **CL**

*Direct department key: To display the department total amount
⊗ key : To display the amount of total in drawer
ST key : To display the sales total

Item	Mode switch position		Job code	Key operation
	X1/Z1	X2/Z2		
Full reading and resetting	X1, Z1	X1, Z1	100	
		X2, Z2	200	
Individual cashier reading and resetting	X1, Z1	X1, Z1	151	
		X2, Z2	251	
	<OP X/Z> X, Z		51	
Full cashier reading and resetting	X1, Z1	X1, Z1	150	
		X2, Z2	250	
Reading and resetting of hourly sales information	X1		160	
	X1, Z1			

* Enter the time in the 24-hour system.

Item	Mode switch position		Job code	Key operation
	X1/Z1	X2/Z2		
Full department reading	X1	X1	110	110 → ⊗ → TL 210 → ⊗ → TL
		X2	210	
Individual group reading	X1	X1	112	112 → ⊗ → Group no. → TL 212 → ⊗ → TL
		X2	212	
Full group reading	X1	X1	113	113 → ⊗ → TL 213 → ⊗ → TL
		X2	213	
Reading and resetting of sales information for a range of PLUs/subdepartments	X1	X1	120	120 → ⊗ → TL 220 → ⊗ → TL All codes → TL Start PLU code → ⊗ → End PLU code → TL
		X2	220	
Reading of sales information of PLUs/subdepartments associated with an individual department	X1	X1	121	121 → ⊗ → Dept. code → TL 221 → ⊗ → TL
		X2	221	
Reading of information on PLUs/subdepartments whose sales amounts are zeros	X1	X1	127	127 → ⊗ → TL 227 → ⊗ → TL
		X2	227	
Reading of sales information for the price amount range of PLUs/sub department	X1	X1	129	129 → ⊗ → TL 229 → ⊗ → TL All codes → TL Start price amount → ⊗ → End price amount → TL
		X2	229	
PLU stock information	X1	X1	124	124 → ⊗ → TL 224 → ⊗ → TL All codes → TL Start PLU code → ⊗ → End PLU code → TL
		X2	224	
Commission sales report	X1	X1	132	132 → ⊗ → TL 232 → ⊗ → TL
		X2	232	
Transaction reading	X1	X1	130	130 → ⊗ → TL 230 → ⊗ → TL
		X2	230	
Total in drawer	X1	X1	131	131 → ⊗ → TL 231 → ⊗ → TL
		X2	231	
Reading and resetting of a stacked report	X1, Z1	X1, Z1	190	190 → ⊙ → TL 290 → ⊙ → TL Reading → ⊙ → TL Resetting → ⊙ → TL When Z of stacked report is initiated, X only reports will be skipped.
		X2, Z2	290	
Reading and resetting of the daily net totals		X2, Z2	270	270 → ⊙ → TL Reading → ⊙ → TL Resetting → ⊙ → TL

2 Daily sales totals

Full reading and resetting of sales totals

With this features, you can take X and Z reports for individual department and transaction sales, as well as for cash/cheque in drawer, but not for PLU sales, and hourly sales.

• Sample X report

26/08/96 18:10	11	
123456 #2235	MEVER	
#100	X<X1X	Report no. Read symbol
%DEPT%		
D01	40.000 Q	Dept. no.
DPT.01	¥493.60	Sales q'ty
	27.99%	Sales amount
D06	31.000 Q	Ratio of dept. 1 sales amount to dept. group 1 total
DPT.06	¥1270.20	
	72.01%	
GROUP01	71.000 Q	
	¥1763.80	
	44.17%	Ratio of dept. group 1 sales amount to "+ dept. total

%DEPT TL	240.000 Q	} "+ dept. counter and total
	¥3992.99	
	100.00%	
D08	12.000 Q	} "- dept. counter and total
DPT.08	-54.00	
DEPT(-)	12.000 Q	
	-54.00	
D09	1.000 Q	} "+ hash dept. counter and total
DPT.09	¥3.00	
XHASH TL	1.000 Q	
	¥3.00	
D10	5.000 Q	} "- hash dept. counter and total
DPT.10	-17.50	
HASH(-)	5.000 Q	
	-17.50	

• Sample Z report

27/08/96 20:04	11	
123456 #2374	MEVER	
#100	XZ1X	Report no. Reset symbol
	Z1 0002	Reset counter
GT1	¥00000014086.93	Net grand total (GT2 - GT3)
GT2	¥00000014498.94	Grand total of plus registration
GT3	-00000000412.01	Grand total of minus registration
TR	¥00000000137.75	Grand total of training mode registration

The subsequent printout occurs in the same format as in the X report.

To be continued on the next page

D11	3.000 Q	} "+" bottle return dept. counter and total
DPT.11	¥6.00	
XB TTL TL	3.000 Q	
	¥6.00	
D12	3.000 Q	} "-." bottle return dept. counter and total
DPT.12	-7.50	
B TTL(-)	3.000 Q	
	-7.50	
* TRANS. *		
(-) 1	3 Q	} ⊖1 counter and total
	-6.00	
(-) 2	2 Q	} ⊖2 counter and total
	-1.00	
SET PLU-	-54.00	— Set PLU discount
≈1	6 Q	} Percent 1 counter and total
	-42.63	
≈2	1 Q	} Percent 2 counter and total
	¥0.48	
NET1	¥3834.34	— Net sales total
TAX1 ST	¥955.84	— Taxable 1 total
VAT 1	¥27.84	— VAT1 total
TAX2 ST	¥565.20	
VAT 2	¥36.98	
TAX3 ST	¥532.40	
VAT 3	¥20.48	
TTL TAX	¥85.30	— Tax total
NET	¥3749.04	— Net sales total without VAT
VAT SFT	¥18.20	— VAT shift total
TAX DELE	¥30.00	— Tax delete total
(-) 3	1 Q	} ⊖ Item counter and total
	-1.00	
(-) 4	2 Q	} Item percent counter and total
	-1.60	
≈3	3 Q	
	-3.75	
≈4	2 Q	} Coupon-like PLU counter and total
	-4.36	
CP PLU	2 Q	
	-52.00	
REFUND	2 Q	} Refund counter and total
	¥17.00	
⊛	5 Q	} REG-mode item void counter and total
	¥11.50	
⊛ MODE	2 Q	} Void-mode transaction counter and total
	¥55.00	

To be continued on the next page

MGR 0	2 Q	Manager item void counter and total
	\$55.00	
SETL 0	1 Q	Subtotal void counter and total
	\$3.20	
HASH 0	2 Q	Hash item void counter and total
	\$6.50	
HASH RF	2 Q	Hash item refund counter and total
	\$6.00	
VP CNT	2 Q	Validation print counter
NO SALE	5 Q	No-sale (exchange) counter
G.C. CNT	2 Q	Guest check copy counter
GUEST	160 Q	Customer counter
ORDER TL	\$3819.84	Order total
PAID TL	\$3819.84	Paid total
AVE.	\$23.87	Paid total average per customer
O-F	\$0.00	Order total-paid total
XXXRA	1 Q	Received on account counter and total
	\$25.00	
XXXRA2	1 Q	Received on account 2 counter and total
	\$12.00	
XXXPD	2 Q	Paid out counter and total
	\$27.00	
XXXPD2	1 Q	Paid out 2 counter and total
	\$18.00	
CA/CHK	1 Q	Cheque cashing counter and total
	\$30.00	
CASH	128 Q	Cash counter and total
	\$2809.44	
CASH2	1 Q	Cash 2 counter and total
	\$43.00	
CHECK	5 Q	Cheque 1 sale counter and total
	\$142.40	
CHECK2	2 Q	
	\$58.50	
CHECK3	2 Q	
	\$98.20	
CHECK4	2 Q	
	\$94.20	
CREDIT1	3 Q	Credit 1 sales and tendering counter and total
	\$72.00	
CREDIT2	3 Q	
	\$73.00	
CREDIT3	2 Q	
	\$36.50	
CREDIT4	2 Q	
	\$57.90	

EXCH1	4 Q	Exchange 1 counter and total
	\$98.32	
DDM.CUR1	\$161.99	
EXCH2	2 Q	
	\$79.88	
DDM.CUR2	\$64.50	
EXCH3	2 Q	
	\$186.83	
DDM.CUR3	\$83.28	
EXCH4	2 Q	
	\$47.13	
DDM.CUR4	\$37.70	
XXXXCID	\$2794.67	Cash in drawer
XCH ID	\$430.30	Cheque in drawer
CA/CH ID	\$3224.97	Cash + cheque in drawer
CHK/CG	\$3.00	Change total for cheque tendering

■ Cashier reading and resetting

Using this function, you can take X and Z reports for individual cashiers or all cashiers.

Individual cashier reading and resetting

Note The OP X/Z-mode reading and resetting is allowed only when your machine has been programmed for "OP X/Z mode available" in the PGM2 mode.

• Sample X report

26/08/96 18:15	11	
123456 #2236	MEYER	
#151 *X1*		
*CASHIER *		
01CSR#1 1	MEYER	Cashier no.
ORDER TL	¥5239.84	Cashier code
COM.SAL1	¥540.00	Cashier name
COM.AMT1	¥64.80	Order total
COM.SAL2	¥2097.00	Commission sale 1 total
COM.AMT2	¥880.74	Commission amount 1
COM.SAL3	¥1598.20	
COM.AMT3	¥559.37	
COM.TTL	¥1504.91	Commission amount total
NON COM.	¥1053.79	Non commission sales amount
PAID TL	¥5239.84	
REFUND	4 0	
	¥23.00	
	7 0	
	¥18.00	
MODE	2 0	
	¥55.00	
MGR "	2 0	
	¥55.00	
SBTL "	1 0	
	¥3.20	
G.C. CNT	2 0	
GUEST	186 0	
***RA	1 0	
	¥25.00	
***RA2	1 0	
	¥12.00	
***PO	2 0	
	¥27.00	
***PO2	1 0	
	¥18.00	
CA/CHK	1 0	
	¥30.00	
CASH	154 0	
	¥4229.44	
CASH2	1 0	
	¥43.00	

• Sample Z report

26/08/96 20:16	11
123456 #2270	MEYER
#151 *Z1*	
*CASHIER *	

The subsequent printout occurs in the same format as in the sample X report.

CHECK	5 0
	¥142.40
CHECK2	2 0
	¥58.50
CHECK3	2 0
	¥98.20
CHECK4	2 0
	¥94.20
CREDIT1	3 0
	¥72.00
CREDIT2	3 0
	¥73.00
CREDIT3	2 0
	¥36.50
CREDIT4	2 0
	¥57.90
EXCH1	4 0
	98.32
DDM.CUR1	¥161.99
EXCH2	2 0
	79.88
DDM.CUR2	¥64.50
EXCH3	2 0
	186.83
DDM.CUR3	¥83.28
EXCH4	2 0
	47.13
DDM.CUR4	¥37.70

***CID	¥4214.67
*CH ID	¥430.30
CA/CH ID	¥4644.97
CHK/CG	¥3.00
D02	11.000 0
DPT.02	¥440.00
D04	7.000 0
DPT.04	¥29.00

Dept. code
Sales q'ty
Sales amount

* When you take these reports in the OP X/Z mode, the X report shows an "OP X" and the Z report shows an "OP Z".

Full cashier reading and resetting

```
26/08/96 18:20      11  
123456 #2237  MEVER  
  
#150 *Z1*  
*CASHIER *
```

```
26/08/96 20:19      11  
123456 #2271  MEVER  
  
#150 *Z1*  
*CASHIER *
```

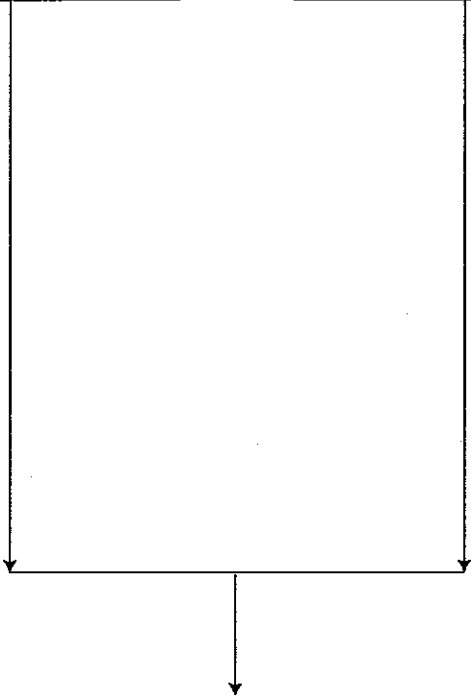

The subsequent printout occurs in the same format as in the sample report shown in previous page: and sales data for cashiers print in this sequence.

■ Reading and resetting of hourly sales information

You can take X and Z reports for sales totals and transaction (customer) counters for 48 half hours, or 48 quarter hours. If both quantity and amount are zero, their print is skipped.

• Sample X report

26/08/96 18:55	11
123456 #2238	MEVER
#160 *X*1*	
* HOURLY *	
9:00	22 Q
	¥660.00
AVE.	¥30.00
9:30	24 Q
	¥840.00
AVE.	¥35.00
SUBTOTAL	46 Q
	¥1500.00
10:00	25 Q
	¥970.00
AVE.	¥38.80
10:30	28 Q
	¥1110.00
AVE.	¥39.64
SUBTOTAL	53 Q
	¥2080.00

• Sample Z report

26/08/96 20:30	11
123456 #2275	MEVER
#160 *Z*1*	
* HOURLY *	

The subsequent printout occurs in the same format as in the sample X report.

17:00	30 Q	Customer counter
	¥1190.00	Sales total
AVE.	¥39.67	Average sales amount per customer (sales total ÷ customer counter)
17:30	27 Q	
	¥1010.00	
AVE.	¥37.41	
SUBTOTAL	57 Q	
	¥2200.00	
18:00	25 Q	
	¥820.00	
AVE.	¥32.80	
18:30	34 Q	
	¥1520.00	
AVE.	¥44.71	
SUBTOTAL	59 Q	
	¥2340.00	

■ Full department reading

26/08/96 18:24	11
123456 #2241	MEVER
#110 *X1*	
DEPT	
D01	40.000 Q
DPT.01	¥493.60
	27.99%
D06	31.000 Q
DPT.06	¥1270.20
	72.01%
GROUP01	71.000 Q
	¥1763.80
	44.17%

Sales q'ty and total

Ratio of dept. 1 sales amount to dept. group 1 total

■ Individual group reading

26/08/96 18:26	11
123456 #2242	MEVER
#112 *X1*	
*GROUP *	
D01	40.000 Q
DPT.01	¥493.60
D06	31.000 Q
DPT.06	¥1270.20
GROUP01	71.000 Q
	¥1763.80

Group 1 sales q'ty and total

■ Full group reading

*DEPT TL	240.000 Q
	¥3992.99
	100.00%
D08	12.000 Q
DPT.08	-54.00
DEPT(-)	12.000 Q
	-54.00
D09	1.000 Q
DPT.09	¥3.00
*HASH TL	1.000 Q
	¥3.00
D10	5.000 Q
DPT.10	-17.50
HASH(-)	5.000 Q
	-17.50
D11	3.000 Q
DPT.11	¥6.00
*BTTL TL	3.000 Q
	¥6.00
D12	3.000 Q
DPT.12	-7.50
BTTL(-)	3.000 Q
	-7.50
SET PLU-	-54.00

26/08/96 18:27	11
123456 #2243	MEVER
#113 *X1*	
*GROUP *	
GROUP01	71.000 Q
	¥1763.80
	44.17%
GROUP02	76.000 Q
	¥777.75
	19.48%

Group 1 sales q'ty and total

*DEPT TL	240.000 Q
	¥3992.99
	100.00%
DEPT(-)	12.000 Q
	-54.00
*HASH TL	1.000 Q
	¥3.00
HASH(-)	5.000 Q
	-17.50
*BTTL TL	3.000 Q
	¥6.00
BTTL(-)	3.000 Q
	-7.50

■ Reading and resetting of sales information for a range of PLUs/subdepartments

This function provides you with X and Z reports for sales information of a certain range of PLUs/subdepartments. You designate the start and end PLU/subdepartment code of the range. Of course, the range may represent all of the PLUs/subdepartments in your register.

• Sample X report

26/08/96 18:28		11
123456 #2244		MEVER
#120 %Z1%		
% PLU %		
	000001-000020	Range
PLU code	F000001	8.000 Q
Item label	PL000001	¥9.60
	F000002	8.000 Q
	PL000002	¥119.25
	F000003	4.000 Q
	PL000003	¥20.00
	F000005	8.000 Q
	PL000005	-82.00
	F000006	5.000 Q
	PL000006	¥99.20

Sales q'ty and total

	F000019	2.000 Q
	PL000019	¥34.00
	F000020	2.000 Q
	PL000020	¥36.00
	***TOTAL	67.000 Q
		¥618.05
	SET PLU-	-54.00
	%SET PLU %	
	F000011	6.000 Q
	PL000011	¥72.00
	***TOTAL	6.000 Q
		¥72.00

Range sum

• Sample Z report

26/08/96 20:31		11
123456 #2276		MEVER
#120 %Z1%		
% PLU %		

The subsequent printout occurs in the same format as in the sample X report.

■ Reading of sales information on PLUs/subdepartments associated with an individual department

```

26/08/96 18:30      11
123456 #2245      MEYER

#121 *X1*
* PLU *

DPT.01      001
PLU code — F000001      8.000 Q
            PL000001      *9.60
            F000018      2.000 Q
            PL000018      *30.00
            F000019      2.000 Q
            PL000019      *34.00

            ***TOTAL      12.000 Q
                                *73.60

            SET PLU-      -54.00

            *SET PLU *
            F000011      6.000 Q
            PL000011      *72.00

            ***TOTAL      6.000 Q
                                *72.00
    
```

PLU code

Associate
dept. code
Sales q'ty
and total

■ Reading of sales information on PLUs/subdepartments whose sales amounts are zeros

```

26/08/96 18:32      11
123456 #2246      MEYER

#127 *X1*
XZERO SALX

F000004
PL000004
F000007
PL000007
F000010
PL000010
    
```

PLU
code
Text

■ Reading of sales information for the price amount range of PLUs/subdepartments

```

26/08/96 18:33      11
123456 #2247  MEYER

#129 *K1*
*CATEGORY*

      1.00 -   10.00
P000001      8.000 Q
PL000001      *9.60
P000003      4.000 Q
PL000003      *20.00
P000009      3.000 Q
PL000009      *6.00
P000012      6.000 Q
PL000012      *12.00
P000013      6.000 Q
PL000013      *24.00
P000017      2.000 Q
PL000017      *20.00
    
```

Price amount range

Sales q'ty and total

■ PLU stock information

```

26/08/96 18:34      11
123456 #2248  MEYER

#124 *K1*
* STOCK *

      000001-000010
P000001
PL000001      12.000 S
P000002
PL000002      2.000 S
P000003
PL000003      11.000 S
P000004
PL000004      0.000 S
P000005
PL000005      37.000 S
P000006
PL000006      45.000 S
P000007
PL000007      0.000 S
P000008
PL000008      7.000 S
P000009
PL000009      7.000 S
P000010
PL000010      0.000 S
    
```

Range

Current stock

■ Commission sales information

```

26/08/96 18:42      11
123456 #2265  MEYER

#132 *K1*
* SALES *

COM.SAL1      *540.00
COM.AMT1      *64.80
COM.SAL2      *1637.00
COM.AMT2      *687.54
COM.SAL3      *1598.20
COM.AMT3      *559.37
COM.TTL      *1311.71
NON COM.      *1021.79

NET1          *4762.34
    
```

Commission sales 1 total

Commission amount 1

Commission amount total

Transaction reading

```

26/08/96 18:43      11
123456 #2266      MEYER

#130 *X<1*
* TRANS. *
    
```

In this report the same transaction data as those printed when full reading is taken are printed.

Total in drawer reading

```

26/08/96 18:45      11
123456 #2267      MEYER

#131 *X<1*
* TL-ID *

EXCH1                4 0
                    98.32
DOM.CUR1             *161.99
EXCH2                2 0
                    79.88
DOM.CUR2             *64.50
EXCH3                2 0
                    186.83
DOM.CUR3             *83.28
EXCH4                2 0
                    47.13
DOM.CUR4             *37.70

***XCID             *3722.67
XCH ID               *430.30
CA/CH ID             *4152.97
    
```

Exchange 1 counter
 Currency exchange 1 total
 Domestic currency for currency exchange 1 total
 Cash in drawer
 Cheque in drawer
 Cash/Cheque in drawer

Reading and resetting of a stacked report

You can print multiple X1/Z1 reports in sequence at a time.

In this case you need to program in advance what X1/Z1 reports should be printed.

Note

The following job code numbers alone can be used for stacked report printing.

Job code number: 100, 110, 113, 120, 124, 127, 129, 130, 131, 132, 150, 160, 170

Refer to "Selection of X/Z reports to be printed in the stacked report sequence" for details.

3 Periodic consolidation

Your register allows you to take consolidation X and Z reports of a chosen period (normally one week or a month).

■ General information

The periodic reading or resetting reports are the same in format as those in the X1/Z1 report for daily total except job code no. (#2xx) and mode indication ("X2" or "Z2".)

• Sample X report

```
26/08/96 20:10      11
123456 #2264      MEVER
#200 %X2%
```

Read symbol

• Sample Z report

```
28/08/96 19:34      11
123456 #2504      MEVER
#200 %Z2%
Z1 0003
Z2 0001
GT1 %00000024286.93
GT2 %00000024798.94
GT3 -00000000512.01
TR  %00000000137.75
```

Reset symbol
Reset counter of daily total
Reset counter of periodic consolidation
Grand total

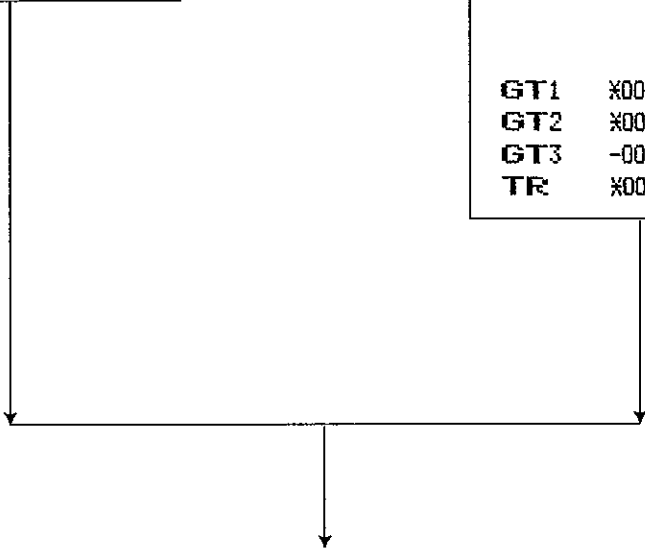

The subsequent printouts are the same in format as those in the X/Z report for daily total.

■ Reading and resetting of the daily net totals

31/08/96 19:56	11
123456 #2711	MEVER
#270 XZ2X	
X DAILY X	
01/08	62 Q
	X2561.96
02/08	59 Q
	X2658.82
03/08	56 Q
	X2855.13
04/08	69 Q
	X3768.72
05/08	64 Q
	X4063.22
28/08	71 Q
	X5070.63
29/08	64 Q
	X4163.20
30/08	57 Q
	X4156.65
31/08	54 Q
	X3653.84
***TOTAL	556 Q
	X32952.17

31/08/96 20:34	11
123456 #2721	MEVER
#270 XZ2X	
X DAILY X	



The subsequent printout occurs in the same format as in the sample X report.

■ Reading and resetting of a stacked report

You can print multiple X1/Z1 reports in sequence at a time.

In this case you need to program in advance what X1/Z1 reports should be printed.

Note

The following job code numbers alone can be used for stacked report printing.

Job code number: 200, 210, 213, 227, 229, 230, 231, 232, 250, 270

Refer to "Selection of X1/Z1 and X2/Z2 reports to be printed in the stacked report sequence" for details.

COMPULSORY CASH/CHEQUE DECLARATION

If your machine has been programmed for compulsory cash/cheque declaration, you must declare cash/cheque in drawer in advance according to the type of the declaration when you take cashier Z reports.

Use the procedure shown in "Key operation" below for this declaration.

Types of compulsory cash/cheque declaration

- Compulsive when individual cashier resetting is taken
- Compulsive when full cashier resetting is taken

Note Compulsory cash/cheque declaration is available in the above two types. You can choose either of these. Consult your local dealer for details.

Key operation

• Individual cashier Z report

OP X/Z mode

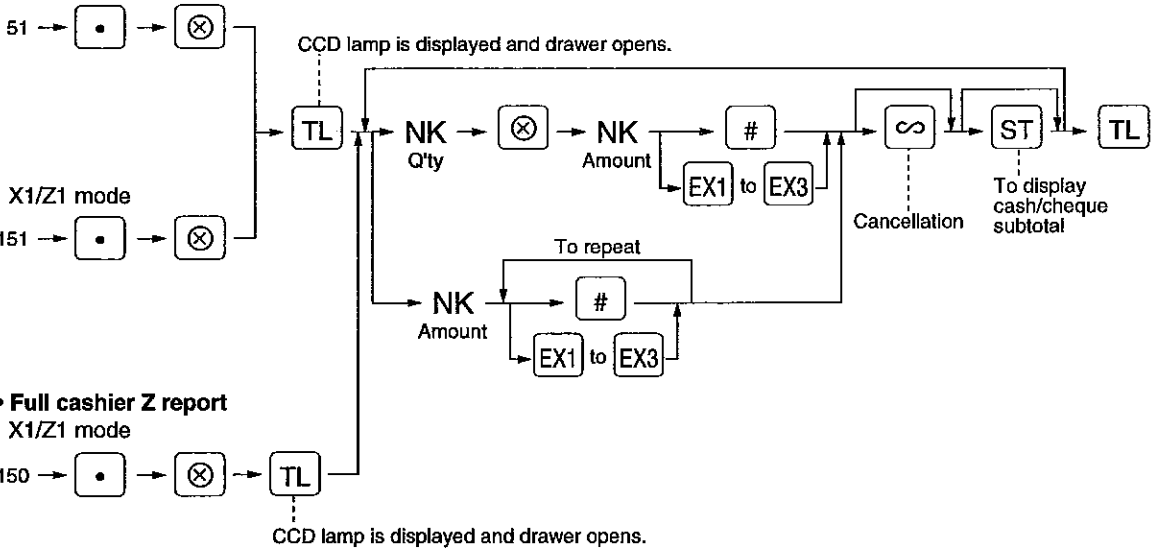

[#] : For Cash/cheque in drawer, [EX1] to [EX3] : For foreign currency in drawer

26/08/96 20:16 11
 123456 #2272 MEYER

#151 *Z1*
 * CCD *

CA/CH IS ¥4644.97
 EXCH1 IS 98.32
 EXCH2 IS 79.88
 EXCH3 IS 186.83

*CASHIER *

OICSR#1 1 MEYER
 ORDER TL ¥5239.84
 COM.SAL1 ¥540.00
 COM.AMT1 ¥64.80
 COM.SAL2 ¥2097.00
 COM.AMT2 ¥880.74

D02	11.000 Q
DPT.02	¥440.00
D04	7.000 Q
DPT.04	¥29.00

CCD entry amount

CREDIT3 2 Q
 ¥36.50

CREDIT4 2 Q
 ¥57.90

EXCH1 4 Q
 98.32

EXCH1 IS 98.32
 CCD DIF. 0.00

DDM.CUR1 ¥161.99

EXCH2 2 Q
 79.88

EXCH2 IS 79.88
 CCD DIF. 0.00

DDM.CUR2 ¥64.50

EXCH3 2 Q
 186.83

EXCH3 IS 186.83
 CCD DIF. 0.00

DDM.CUR3 ¥83.28

EXCH4 2 Q
 47.13

DDM.CUR4 ¥37.70

*** ID ¥4214.67
 XCH ID ¥430.30
 CA/CH ID ¥4644.97
 CA/CH IS ¥4644.97
 CCD DIF. ¥0.00
 DIF. TL ¥0.00
 CHK/CG ¥3.00

Currency exchange 1 in drawer to be obtained
 Total of entered (declared) exchange 1 in drawer
 Difference

Cash in drawer to be obtained
 Cheque in drawer to be obtained
 Cash/cheque in drawer to be obtained
 Total of entered (declared) cash/cheque in drawer
 Difference
 Total of difference

OVERRIDE ENTRIES

Programmed limit for functions (such as for maximum amounts) can be overridden by making an entry in the MGR mode.

Procedure

1. Turn the mode switch to the MGR position.
2. Make an override entry.

Example

Key operation

1500
REG-mode 250 ...Error
entries

Turn the mode switch
to the MGR position.
250

Return the mode switch
to the REG position.

Print

DPT.02	¥15.00
(-)1	-2.50
CASH	¥12.50

CORRECTION AFTER FINALIZING A TRANSACTION (AFTER GENERATING A RECEIPT)

When you need to void incorrect entries that cashiers cannot correct (incorrect entries that are found after finalizing a transaction or cannot be corrected by direct or indirect void), follow this procedure in the MGR mode.

1. Turn the mode switch to the MGR position.
2. Press the  key to put your register in the VOID mode.
3. Repeat the entries that are recorded on an incorrect receipt. (All data for the incorrect receipt are removed from register memory; the voided amounts are added to the void register totalizer.)

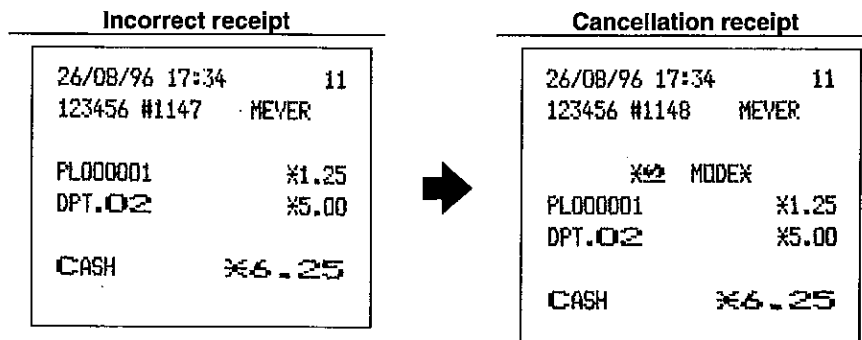

Note Your machine leaves the VOID mode whenever a transaction is canceled (i.e. finalized in the VOID mode.) To void additional transactions repeat steps 2. and 3. above.

TIME DISPLAY AND AUTOMATIC UPDATING OF THE DATE

1 Time display

When you need a time display, turn the mode switch to the OP X/Z position after the preceding transaction or operation is finalized.

You can also display the time by pressing the  key in the REG or MGR mode.

Sample display of 10:25

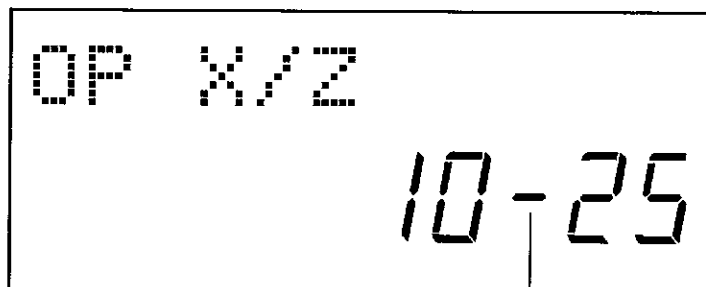

This bar flashes every 0.5 seconds

2 Automatic updating of the date

Once the internal clock unit is started at the correct time, it continues to run as long as the built-in battery is charged, and updates the date (day, month, year) properly. Normally the date is updated at 24:00.

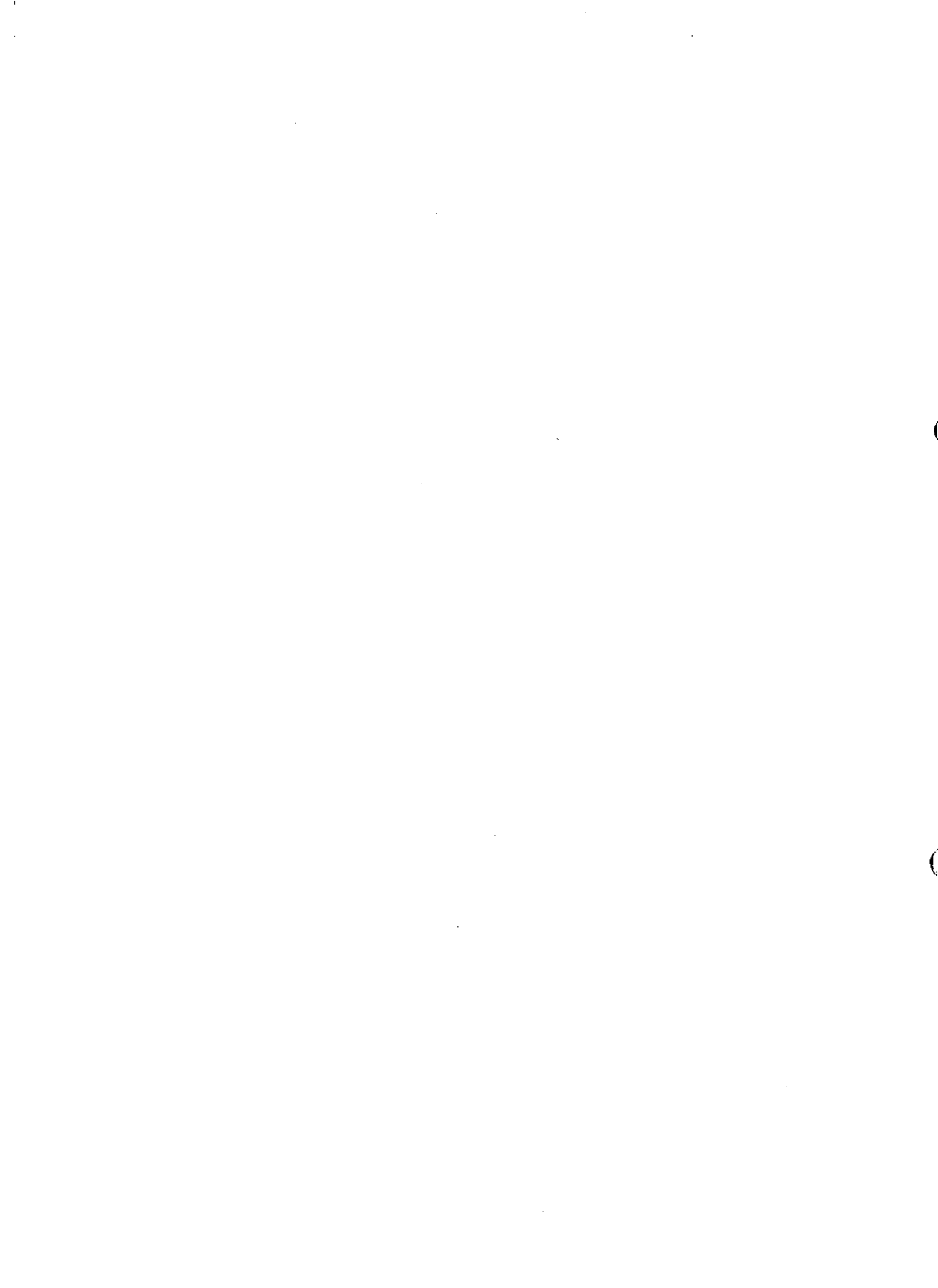

FOR THE OPERATOR

PRIOR TO ENTRIES

1 Preparations for entries

1. Insert the operator key into the mode switch and turn it to the REG position.
2. Check to see if your register has both the journal and receipt rolls. If your register lacks these rolls or has low rolls, install new paper rolls or replace the old rolls with new ones according to "4 Installing and removing the paper roll" under "OPERATOR MAINTENANCE".
3. Enter an appropriate cashier code (one or two digits) with the **CASH #** key. This may not be necessary when the same cashier code is used in the next transaction.

Procedure

To display the current cashier code

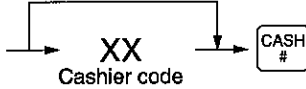

Note

The real cashier key system is also available. If you want to change the cashier system, consult your local dealer.

2 Error warning

In the following examples, your register will go into an error state accompanied with a warning beep and the error message on the display. Clear the error state by pressing the **CL** key and take a proper action.

- When you enter an over 32-digit number (entry limit overflow): Cancel the entry and re-enter a correct number.
- When you make an error in key operation: Clear the error and do correct operation.
- When you make an entry beyond a programmed amount entry limit: Check to see if the entered amount is correct. If it is correct, it can be rung up in the MGR mode. Contact your manager.
- When an including-tax subtotal exceeds eight digits: Delete the subtotal by pressing the **CL** key and press the **TL**, **CA2**, **CH** through **CH4** or **CR1** through **CR4** key to finalize the transaction.

ENTRIES

1 Item entries

■ Single item entries

Entries into departments

Enter a unit price and press a department key.

If you use a programmed unit price, press a department key only.

Procedure

When using a programmed price

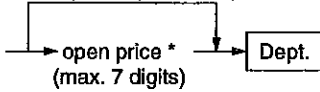

¹Less than the programmed upper limit amounts

Example

Key operation

1200

Print

```
26/08/96 10:30      11
123456 #1102  MEVER

DPT.06             ¥12.00
DPT.07             ¥5.00

CASH               ¥17.00
```

Note

When those departments for which the unit price has been programmed as zero (0) are entered with the preset unit price, only the sales quantity is added.

PLU entries (indirect PLU entries)

Enter a PLU code and press the **PLU/SUB** key.

Procedure

→ PLU code → **PLU/SUB**

Example

Key operation

2 **PLU/SUB**
TL

Print

PL000002	¥1.50
CASH	¥1.50

Note

When those PLUs for which the unit price has been programmed as zero (0) are entered, only the sales quantity is added.

Subdepartment (open PLU) entries

Follow this sequence:

Procedure

→ * open price → **AMT** → PLU code → **PLU/SUB**

*Less than the programmed upper limit of associated department

Example

Key operation

1200 **AMT**
10 **PLU/SUB**
TL

Print

PL000010	¥12.00
CASH	¥12.00

PLU entries (direct PLU entries)

Follow this sequence:

Procedure

When using a programmed price

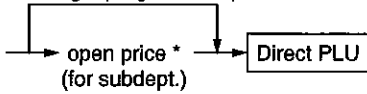

* Less than a programmed upper limit of associated department

Example

Key operation

59
TL

Print

PL000050	¥12.75
CASH	¥12.75

Repeat entries

You can use this function for entering a sale of two or more same items.

Example

Key operation

Repeated department entry	{	200	8
			8
			8
Repeated PLU entry (indirect)	{	10	PLU/SUB
			PLU/SUB
			PLU/SUB
Repeated PLU entry (direct)	{		51
			51
			51
Repeated subdepartment entry	{	600	AMT
		6	PLU/SUB
			PLU/SUB
			TL

Print

DPT.08	¥2.00
DPT.08	¥2.00
DPT.08	¥2.00
PL000010	¥12.00
PL000010	¥12.00
PL000010	¥12.00
PL000051	¥2.85
PL000051	¥2.85
PL000006	¥6.00
PL000006	¥6.00
CASH	¥59.70

■ Multiplication entries

Use this feature when you need to enter two or more same items.

This feature helps when you sell a large quantity of items or need to enter quantities that contain decimals.

Procedure

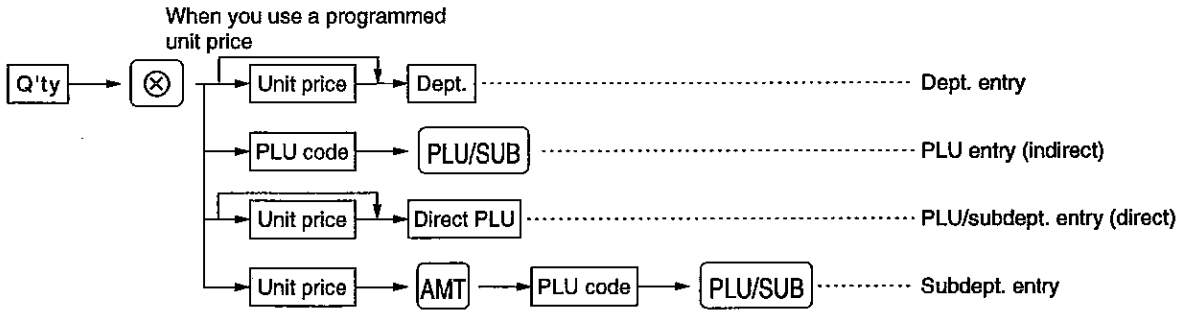

- Q'ty: Up to four digits integer + three digits decimal
- Unit price: Less than a programmed upper limit
- Q'ty x unit price: Up to seven digits

Example

Key operation	Print
Dept. entry { 7 . 5 ⊗	7.5x 1.65
165 8	DPT.08 ¥12.38
PLU entry { 15 ⊗	15x 2.10
13 PLU/SUB	PL000013 ¥31.50
Direct PLU entry { 8 . 25 ⊗	8.25x 1.00
58	PL000058 ¥8.25
Subdepartment entry { 3 ⊗	3x 1.00
100 AMT	PL000010 ¥3.00
10 PLU/SUB	
TL	
	CASH ¥55.13

■ Successive multiplication entries

This function is practical for example when you enter a sale of items sold by area (square meter).

Procedure

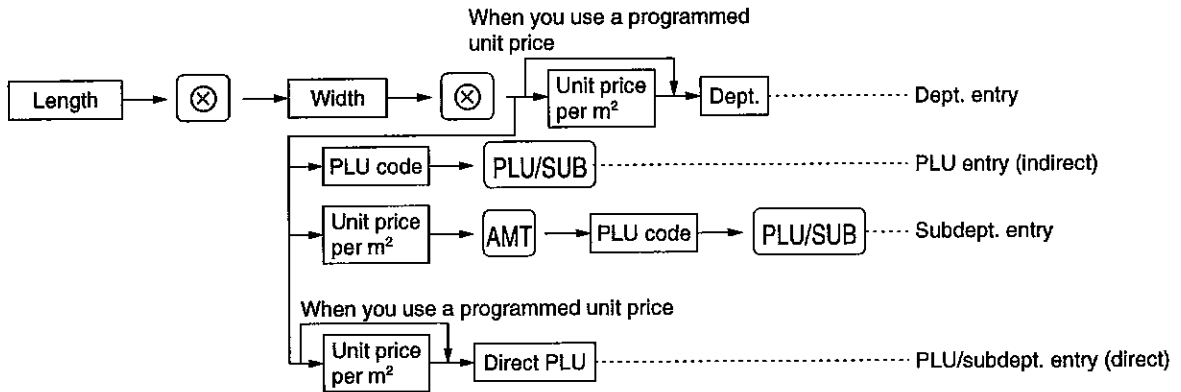

- Length or width: up to seven digits (4-digit integer + 3-digit decimal)
- Unit price: less than a programmed upper limit (max. 9999999)
- Length x Width x Unit price: up to seven digits

Example

Key operation	Print
Department entry { 3 ⊗	<pre> 3x 4x 4.00 DPT.05 ¥48.00 1.5x 2.5x 3.00 PL000008 ¥11.25 1.75x 1.75x 6.00 PL000006 ¥18.38 CASH ¥77.63 </pre>
4 ⊗	
400 5	
PLU entry { 1 . 5 ⊗	
2 . 5 ⊗	
8 PLU/SUB	
Subdepartment entry { 1 . 75 ⊗	
1 . 75 ⊗	
600 AMT	
6 PLU/SUB	
TL	

■ Split-pricing entries

You will use this function when your customer wants to purchase more or less than the base quantity of a loose item.

Procedure

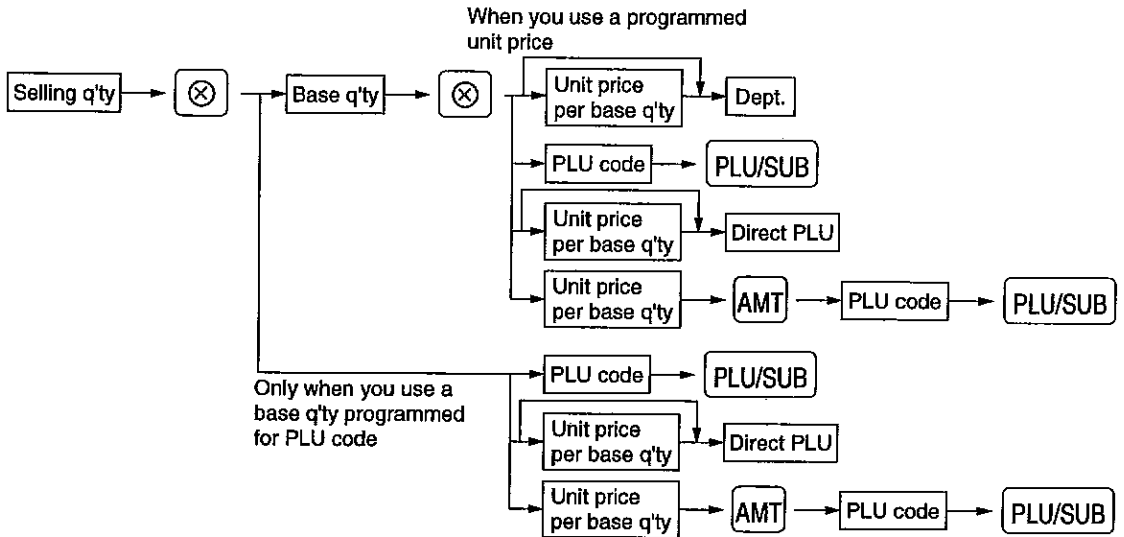

- Selling quantity: Up to four digits integer + three digits decimal
- Base quantity: Up to two digits (integer)

Example

Key operation

```

7 ⊗
10 ⊗
600 7
8 ⊗
5 ⊗
35 PLU/SUB
TL
  
```

Print

```

7x 10/ 6.00
DPT.07          ¥4.20
8x 5/ 3.00
PL00035        ¥4.80

CASH          ¥9.00
  
```

■ Single item cash sale (SICS)/single item finalize (SIF) entries

SICS entries

- This function is useful when a sale is for only one item and is for cash; such as a pack of cigarettes. This function is applicable only to those departments that have been set for SICS or to their associated PLUs or subdepartments.
- The transaction is finalized and the drawer opens as soon as you press the department key, **PLU/SUB** key or the direct PLU key.

Example

Key operation	Print				
250 For finishing → 9 the transaction	<table border="1"> <tr> <td>DPT.09</td> <td style="text-align: right;">¥2.50</td> </tr> <tr> <td>CASH</td> <td style="text-align: right;">¥2.50</td> </tr> </table>	DPT.09	¥2.50	CASH	¥2.50
DPT.09	¥2.50				
CASH	¥2.50				

Note

If a ring-up to a department or PLU/subdepartment set for SICS follows the ones to departments or PLUs/subdepartments not set for SICS, it does not finalize and results in a normal sale.

SIF entries

- If a ring-up to a department or PLU/subdepartment set for SIF follows the ones to departments or PLUs/subdepartments not set for SIF, the transaction is finalized immediately as a cash sale.
- Like the SICS function, this function is available for single-item cash settlement.

Example

Key operation	Print						
1745 8 1500 For finalizing → 9 the transaction	<table border="1"> <tr> <td>DPT.08</td> <td style="text-align: right;">¥17.45</td> </tr> <tr> <td>DPT.09</td> <td style="text-align: right;">¥15.00</td> </tr> <tr> <td>CASH</td> <td style="text-align: right;">¥32.45</td> </tr> </table>	DPT.08	¥17.45	DPT.09	¥15.00	CASH	¥32.45
DPT.08	¥17.45						
DPT.09	¥15.00						
CASH	¥32.45						

2 Special entries for PLUs

■ PLU level shift (for direct PLU)

This shift can double or triple the number of PLUs on your register without adding additional direct PLU keys. You can use direct PLUs in three levels by utilizing shift keys **L1**, **L2**, and **L3**. These keys have the following functions.

L1: Shifts the PLU level from level 2 or 3 to level 1 (normal level).

L2: Shifts the PLU level from level 1 or 3 to level 2.

L3: Shifts the PLU level from level 1 or 2 to level 3.

You must program your machine in the PGM mode to select one of the two PLU level shift modes — automatic return mode* and lock shift mode** — and decide whether to allow PLU level shift in both the REG and MGR modes or in the MGR mode alone.

* The automatic return mode automatically shifts the PLU level back to level 1 after a direct PLU key is pressed.

** The lock shift mode holds the current PLU level until depression of a PLU level shift key.

Automatic return mode

If you shift the PLU level in the automatic return mode, press a desired PLU level shift key before numeric entry.

Procedure

- each item

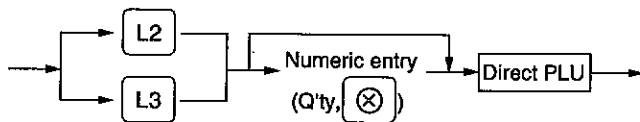

- each transaction

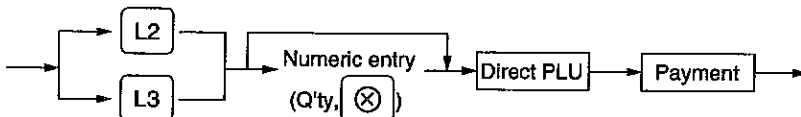

Lock shift mode

If you shift the PLU level in the lock shift mode, press a desired PLU level shift key before numeric entry.

Procedure

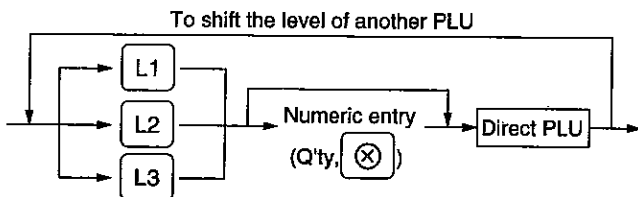

Note

If you select the automatic return mode, it is not necessary to use the **L1** key on the keyboard, but if you select the lock shift mode, it is necessary to use the key.

Example

- When your machine has been programmed for the automatic return mode:

Key operation	Print										
	<table border="1"><tr><td>PL000001</td><td>¥1.25</td></tr><tr><td>PL000065</td><td>¥12.00</td></tr><tr><td>PL000002</td><td>¥1.50</td></tr><tr><td>PL000001</td><td>¥1.25</td></tr><tr><td>CASH</td><td>¥16.00</td></tr></table>	PL000001	¥1.25	PL000065	¥12.00	PL000002	¥1.50	PL000001	¥1.25	CASH	¥16.00
PL000001	¥1.25										
PL000065	¥12.00										
PL000002	¥1.50										
PL000001	¥1.25										
CASH	¥16.00										

- When your machine has been programmed for the lock shift mode:

Key operation	Print										
	<table border="1"><tr><td>FLO00001</td><td>¥1.25</td></tr><tr><td>FLO00065</td><td>¥12.00</td></tr><tr><td>FLO00066</td><td>¥30.00</td></tr><tr><td>FLO00065</td><td>¥12.00</td></tr><tr><td>CASH</td><td>¥55.25</td></tr></table>	FLO00001	¥1.25	FLO00065	¥12.00	FLO00066	¥30.00	FLO00065	¥12.00	CASH	¥55.25
FLO00001	¥1.25										
FLO00065	¥12.00										
FLO00066	¥30.00										
FLO00065	¥12.00										
CASH	¥55.25										

■ Set PLU entries

Operation is the same as normal PLU's.

When a set PLU is entered, an entered or preset amount is printed as the unit price and then the text of those PLUs linked to the set PLU are printed automatically.

Example

Key operation

20
TL

Print

PL000020	¥2.50
PL000201	
PL000202	
CASH	¥2.50

Note

The unit price of the set PLU (ex. PLU 20) is the registered amount of the set PLU. The reduced amount of the unit price of the set PLU from the total of the unit prices of linked PLUs is registered in the set PLU discount memory.

■ Link PLU entries

Operation is the same as normal PLU's. When this PLU is entered, the linked PLU's amount is included and the linked PLU's text is printed automatically.

Example

Key operation

21
TL

Print

PL000021	¥3.50
PL000025	¥3.00
PL000026	¥2.00
PL000027	¥8.00
CASH	¥16.50

3 Displaying and printing subtotals

Your machine provides the following two types of subtotals:

■ Normal subtotal

This is a subtotal which is displayed and printed by pressing the **[ST]** key. When you press it, the subtotal of all entries which have been made is displayed and the "ST" lamp will light up in the display.

Example

Key operation	Display	Print
100 [10]	DPT.10 1.00	DPT.10 ¥1.00
200 [11]	DPT.11 2.00	DPT.11 ¥2.00
700 [12]	DPT.12 7.00	DPT.12 ¥7.00
[ST]	SUBTOTAL 10.00	SUBTOTAL ¥10.00
[TL]	CASH 10.00	TAX1 ST ¥1.00
		VAT 1 ¥0.03
		NET 1 ¥0.97
		TAX2 ST ¥7.00
		VAT 2 ¥0.27
		NET 2 ¥6.73
		 CASH ¥10.00

■ Difference subtotal (Differ ST)

This is a subtotal which is printed by pressing the **[DIFFER ST]** key. You can get two or more difference subtotals in one transaction.

When you press it first, the subtotal of all entries which have been made is displayed and printed. If you press it second, you will get the subtotal of entries which have been made after you last got it. Taxes are calculated each time you press the **[DIFFER ST]** key, and taxes and taxable subtotals are printed on the receipt according to the job# 2616.

Example

Key operation	Display	Print
100 [10]	DPT.10 1.00	DPT.10 ¥1.00
200 [11]	DPT.11 2.00	DPT.11 ¥2.00
[DIFFER ST]	DIFF ST 3.00	SUBTOTAL ¥3.00
700 [12]	DPT.12 7.00	TAX1 ST ¥1.00
[TL]	CASH 10.00	VAT 1 ¥0.03
		NET 1 ¥0.97
		DIFF ST ¥3.00
		DPT.12 ¥7.00
		SUBTOTAL ¥7.00
		TAX2 ST ¥7.00
		VAT 2 ¥0.27
		NET 2 ¥6.73
		DIFF ST ¥7.00
		 CASH ¥10.00

4 Finalization of transaction

■ Cash or cheque tendering

Press the **[ST]** key to get a subtotal, enter the amount tendered by your customer, then press the **[TL]** or **[CA2]** key if it is a cash tender or press one of the **[CH]** through **[CH4]** keys if it is a cheque tender. When the amount tendered is greater than the amount of the sale, your register will show the change due amount and the "→" lamp will light up. Otherwise your register will show a deficit and the "ST" lamp will light up. Make a correct tender entry.

Example

Cash tendering

Key operation

}
[ST]
1000 **[TL]**

Print

***TOTAL	¥7.35
CASH	¥10.00
CHANGE	¥2.65

Cheque tendering

Key operation

}
[ST]
1000 **[CH]**

Print

***TOTAL	¥7.35
CHECK	¥10.00
CHANGE	¥2.65

■ Mixed tendering (cheque + cash)

Example

Key operation

}
[ST]
1000 **[CH]**
500 **[TL]**

Print

***TOTAL	¥14.56
CHECK	¥10.00
CASH	¥5.00
CHANGE	¥0.44

■ Cash or cheque sale that does not need any tender entry

Enter items and press the **[TL]** or **[CA2]** key if it is a cash sale or press one of the **[CH]** through **[CH4]** keys if it is a cheque sale. Your register will display the total sale amount.

Example

Key operation	Print								
300 [6] 10 [PLUS/SUB] [TL]	<table style="width: 100%; border-collapse: collapse;"> <tr> <td style="width: 60%;">DPT.06</td> <td style="text-align: right;">¥3.00</td> </tr> <tr> <td>PL000010</td> <td style="text-align: right;">¥7.15</td> </tr> <tr> <td>CASH</td> <td style="text-align: right;">¥10.15</td> </tr> </table> <p style="text-align: center; margin-top: 10px;">In the case of cheque sale</p> <table style="width: 100%; border-collapse: collapse; border: 1px solid black; margin-top: 5px;"> <tr> <td style="width: 60%;">CHECK</td> <td style="text-align: right;">¥10.15</td> </tr> </table>	DPT.06	¥3.00	PL000010	¥7.15	CASH	¥10.15	CHECK	¥10.15
DPT.06	¥3.00								
PL000010	¥7.15								
CASH	¥10.15								
CHECK	¥10.15								

■ Credit sale

Enter items and press the corresponding credit key.

Example

Key operation	Print						
2500 [6] 3250 [7] [CR2]	<table style="width: 100%; border-collapse: collapse;"> <tr> <td style="width: 60%;">DPT.06</td> <td style="text-align: right;">¥25.00</td> </tr> <tr> <td>DPT.07</td> <td style="text-align: right;">¥32.50</td> </tr> <tr> <td>CREDIT2</td> <td style="text-align: right;">¥57.50</td> </tr> </table>	DPT.06	¥25.00	DPT.07	¥32.50	CREDIT2	¥57.50
DPT.06	¥25.00						
DPT.07	¥32.50						
CREDIT2	¥57.50						

Amount tendering operations (i.e., change calculations) can be achieved by the **[CR1]** through **[CR4]** key when a PGM2 programming allows them.

■ Mixed-tender sale (cash or cheque tendering + credit tendering)

Example

Key operation	Print						
950 <input type="button" value="ST"/> <input type="button" value="TL"/> <input type="button" value="CR2"/>	<table border="1"><tr><td>***TOTAL</td><td>¥49.50</td></tr><tr><td>CASH</td><td>¥9.50</td></tr><tr><td>CREDIT2</td><td>¥40.00</td></tr></table>	***TOTAL	¥49.50	CASH	¥9.50	CREDIT2	¥40.00
***TOTAL	¥49.50						
CASH	¥9.50						
CREDIT2	¥40.00						

Note

Press one of the through keys or the through keys in place of the key when your customer makes payment in cheques or by credit account.

5 Computation of VAT (Value Added Tax)/tax

■ VAT/ tax system

The machine may be programmed for the following six tax systems by your dealer.

Automatic VAT 1, 2, 3 system (Automatic operation method using programmed percentages)

This system, at settlement, calculates VAT for taxable 1, taxable 2, and taxable 3 subtotals by using the corresponding programmed percentages.

Automatic tax 1, 2, 3 system (Automatic operation method using programmed percentages)

This system, at settlement, calculates taxes for taxable 1, taxable 2, and taxable 3 subtotals by using the corresponding programmed percentages, and also adds the calculated taxes to those subtotals, respectively.

Manual VAT 1, 2, 3 system (Manual entry method using programmed percentages)

Procedure

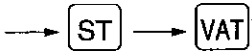

This system provides the VAT calculation for taxable 1, taxable 2, and taxable 3 subtotals. This calculation is performed using the corresponding programmed percentages when the **VAT** key is pressed just after the **ST** key.

Manual VAT 1 system (Manual entry method for subtotals that uses VAT 1 preset percentages)

Procedure

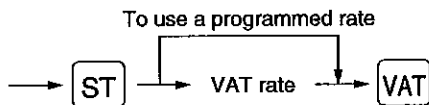

This system enables the VAT calculation for the then subtotal. This calculation is performed using the VAT 1 preset percentages when the **VAT** key is pressed just after the **ST** key. For this system, the keyed-in tax rate can be used.

Manual tax 1, 2, 3 system (Manual entry method using programmed percentages)

Procedure

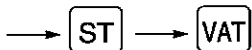

This system provides the tax calculation for taxable 1, taxable 2, and taxable 3 subtotals. This calculation is performed using the corresponding programmed percentages when the **VAT** key is pressed just after the **ST** key. After this calculation, you must finalize the transaction.

Automatic tax 1, 2, 3 and VAT system

This system enables the calculation in the combination with automatic tax 1 through 3 and VAT. This combination can be any of tax 1 through 3 and VAT. The tax amount is calculated automatically with the percentages previously programmed for these taxes.

Example**Key operation**

(When the manual
VAT 1, 2, 3 system
is selected)

550

Print

DPT.08	¥5.50
SUBTOTAL	¥5.50
TAX1 ST	¥5.50
VAT 1	¥0.16
NET 1	¥5.34
CASH	¥5.50

■ VAT shift entries

This feature is intended to shift the tax status of a particular department (or PLU) programmed for taxable 1 or taxable 1 and taxable 3.

1. When the VAT shift entry is made for a particular department or PLU programmed for taxable 1, their tax status shifts to taxable 2.
2. When this entry is made for a particular department (or PLU) programmed for taxable 1 and taxable 3, the tax status "taxable 1" remains unchanged, but the other, "taxable 3" is ignored.

Procedure

Press the key to activate the VAT shift prior to entering department(s) or PLU(s) concerned.

Example**Key operation**

550

Print

DPT.08	¥5.50
SUBTOTAL	¥5.50
TAX2 ST	¥5.50
VAT 2	¥0.21
NET 2	¥5.29
CASH	¥5.50

6 Auxiliary entries

■ Percent calculations (premium or discount)

- Your register provides the percent calculation for the subtotal or each item entry.
- Percentage: 0.01 to 99.99% (Less than the programmed upper limit amount)

Percent calculation for the subtotal

Example

Key operation	Print
(When a discount of 10% is programmed for the [%1] key)	
4 [⊗]	4x 1.40
140 [6]	DPT.06 ¥5.60
225 [7]	DPT.07 ¥2.25
[7]	DPT.07 ¥2.25
[ST]	SUBTOTAL ¥10.10
[%1]	-10.00%
[TL]	¥1 -1.01
	CASH ¥9.09

Percent calculation for item entries

Example

Key operation	Print
(When a premium of 15% is programmed for the [%2] key)	
800 [6]	DPT.06 ¥8.00
[%2]	15.00%
90 [PLU/SUB]	¥2 ¥1.20
7 [•] 5 [%2]	PL000090 ¥5.00
[TL]	7.5%
	¥2 ¥0.38
	CASH ¥14.58

■ Deduction entries

Your register allows you to deduct a certain amount less than a programmed upper limit after the entry of an item or the computation of a subtotal.

Deduction for the subtotal

Example

Key operation

575
 80

 100

Print

DPT.06	¥5.75
PL000080	¥7.50
(-)>2	-1.00
CASH	¥12.25

Deduction for item entries

Example

Key operation

675
 50
 4700
 100

Print

DPT.07	¥6.75
(-)>1	-0.50
DPT.07	¥47.00
(-)>1	-1.00
CASH	¥52.25

■ Refund entries

If a refund item is the one entered into a department, enter the amount of the refund, then press the **[RF]** key and the corresponding department key in this order; and if an item entered into a PLU is returned, enter the corresponding PLU code, then press the **[RF]** and **[PLU/SUB]** keys, or press the **[RF]** and direct PLU keys without entry of PLU code, in this order.

Example

Key operation	Print								
250 [RF] [6] 7 [⊗] 13 [RF] [PLU/SUB] [TL]	<table border="1"> <tr> <td>DPT.06</td> <td>R-2.50</td> </tr> <tr> <td>-7x 2.10</td> <td></td> </tr> <tr> <td>PL000013</td> <td>R-14.70</td> </tr> <tr> <td>CHANGE</td> <td>¥17.20</td> </tr> </table>	DPT.06	R-2.50	-7x 2.10		PL000013	R-14.70	CHANGE	¥17.20
DPT.06	R-2.50								
-7x 2.10									
PL000013	R-14.70								
CHANGE	¥17.20								

■ Printing of non-add code numbers

Enter a non-add code number such as a customer's code number and credit card number within a maximum of 16 digits and press the **[#]** key at any point during the entry of a sale. Your register will print it at once.

Example

Key operation	Print						
1230 [#] 1500 [6] [CH2]	<table border="1"> <tr> <td>#0000000000001230</td> <td></td> </tr> <tr> <td>DPT.06</td> <td>¥15.00</td> </tr> <tr> <td>CHECK2</td> <td>¥15.00</td> </tr> </table>	#0000000000001230		DPT.06	¥15.00	CHECK2	¥15.00
#0000000000001230							
DPT.06	¥15.00						
CHECK2	¥15.00						

7 Payment treatment

■ Currency exchange

Your register allows payment entries of foreign currency. Pressing the **EX1** through **EX4** key creates a subtotal in foreign currency. Cash alone can be handled after currency exchange.

Procedure

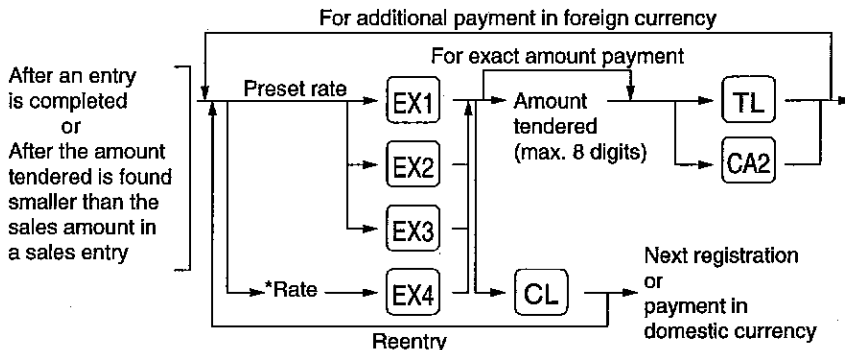

*Rate: 0.0000 to 9999.9999

Note When the amount tendered is short, the deficit is shown in domestic currency.

Example

Preset rate (0.6068) - EX1 to EX3

Key operation	
	2300 6
	4650 7
Currency exchange →	EX1
Amount tendered in foreign currency →	TL

Print

DPT.06	¥23.00	
DPT.07	¥46.50	
***TOTAL	¥69.50	Total in domestic currency
EXCH1	0.6068	Exchange rate
	42.18	Subtotal in foreign currency
CASH	100.00	Amount tendered in foreign currency
CHANGE	¥95.28	
		Change due amount in domestic currency

Manual rate - EX4 (The **EX4** key can be used only for the manual entry)

Key operation	
	2300 6
	4650 7
1 • 275	EX4
	10000 TL

Print

DPT.06	¥23.00
DPT.07	¥46.50
***TOTAL	¥69.50
EXCH4	1.275
	88.62
CASH	100.00
CHANGE	¥8.92

■ Received on account entries

Procedure

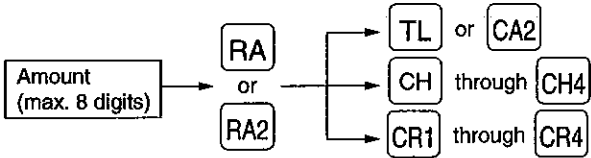

Example

Key operation

```

12345 [#]
4800 [RA]
      [CH]
  
```

Print

```

#00000000000012345
CHECK
***RA           ¥48.00
  
```

■ Paid out entries

Procedure

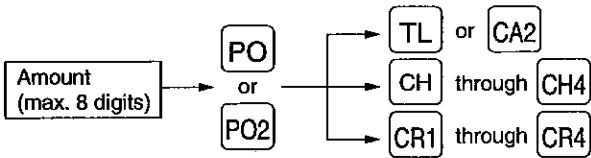

Example

Key operation

```

6789 [#]
3000 [PO]
      [CH]
  
```

Print

```

#0000000000006789
CHECK
***PD           ¥30.00
  
```

■ No sale (exchange)

Simply press the **[NS]** key without any entry. The drawer will open and the printer will print the "NO SALE" on both the journal and the receipt. If you let your machine print a non-add code number before pressing the **[NS]** key, a no sale entry is achieved with a non-add code number printed.

```
#00000000000045678  
NO SALE
```

■ Cashing a cheque

Enter the cheque amount, then press the **[CH]** through **[CH4]** keys.

Procedure

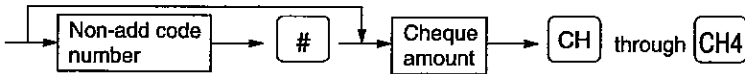

Example

Key operation

```
6789 [#]  
3000 [CH]
```

Print

```
#0000000000006789  
CA/CHK *30.00
```

8 Automatic sequencing key (AUTO key) entries

You can achieve a programmed transaction simply by pressing a corresponding automatic sequencing key.

Example

(**AUTO**₂) = 500 (7) (TL)

Key operation

AUTO₂

Print

DPT.07	¥5.00
CASH	¥5.00

CORRECTION

1 Correction of the last entry (direct void)

If you make an incorrect entry relating to a department, PLU/subdepartment, percentage ($\%1$ through $\%4$), deduction ($\ominus1$ through $\ominus4$) or refund, you can void this entry by pressing the ∞ key immediately after the incorrect entry.

Example

Key operation

1250 $\boxed{6}$
 ∞
 2 $\boxed{\text{PLU/SUB}}$
 ∞
 600 $\boxed{8}$
 $\%2$
 ∞
 328 $\boxed{9}$
 28 $\boxed{\ominus2}$
 ∞
 $\boxed{\text{TL}}$

Print

DPT.06	¥12.50
DPT.06	₩-12.50
PL000002	¥1.50
PL000002	₩-1.50
DPT.08	¥6.00
	15.00%
$\%2$	¥0.90
$\%2$	₩-0.90
DPT.09	¥3.28
$\leftarrow 2$	-0.28
$\leftarrow 2$	₩0.28
CASH	¥9.28

2 Correction of the next-to-last or earlier entries (indirect void)

With the ∞ key, you can void any incorrect positive department or PLU/subdepartment entry made during a transaction if you find it before finalizing the transaction (e.g. pressing the \square TL key). This function is applicable to plus department and PLU/subdepartment entries only.

Example

Key operation	Print
Correction of a department entry	DPT.06 ¥13.10
	DPT.07 ¥17.55
	PL000010 ¥12.00
	PL000035 ¥3.00
Correction of a PLU entry (direct PLU)	PL000058 ¥1.00
	DPT.07 ¥8.25
Correction of a PLU entry (indirect PLU) → 1310 ∞ 6	DPT.06 ¥13.10
	PL000035 ¥3.00
	PL000058 ¥1.00
	CASH ¥37.80

3 Subtotal void

With the ∞ key you can void an entire transaction. Once subtotal void is executed, the transaction is aborted and the register issues a receipt.

Example

Key operation	Print
1310 $\boxed{1}$	DPT.01 ¥13.10
1755 $\boxed{6}$	DPT.06 ¥17.55
10 $\boxed{\text{PLU/SUB}}$	PL000010 ¥12.00
35 $\boxed{\text{PLU/SUB}}$	PL000035 ¥3.00
$\boxed{\text{ST}}$	SUBTOTAL ¥45.65
$\boxed{\infty}$	SBTL 0 -45.65
$\boxed{\text{ST}}$	***TOTAL ¥0.00

4 Correction of incorrect entries not handled by the direct or indirect void function

Any errors found after the entry of a transaction has been completed or during an amount tendered entry cannot be voided. These errors must be handled by the manager.

The following steps should be taken:

1. If you are making the amount tendered entry, finalize the transaction.
2. Make correct entries from the beginning.
3. Hand the incorrect receipt to your manager for its cancellation.

SPECIAL PRINTING FUNCTIONS

1 Copy receipt printing

If your customer wants a receipt after you have finalized a transaction with the receipt ON-OFF function "OFF" status (no receipting), press the **RCPT** key. This will make a copy receipt. Your register can also print a copy receipt when the receipt ON-OFF function "ON" status.

Note Pressing the **RCPT** key in the *OP X/Z* mode before registration toggles the receipt state "ON" and "OFF".

Example Printing a copy receipt after making the entries shown below with the receipt ON-OFF function "OFF" status

Key operation

850 **2**
3 **⊗**
150 **1**
TL

Print

(Journal)

```
26/08/96 18:10      11
123456 #1174  MEYER
DPT.02              ¥8.50
3x 1.50
DPT.01              ¥4.50
CASH                ¥13.00
```

(Receipt)

```
26/08/96 18:10      11
123456 #1174  MEYER
DPT.02              ¥8.50
3x 1.50
DPT.01              ¥4.50
CASH                ¥13.00
```

For receipting → **RCPT**

When the receipt ON-OFF function is in the "ON" status and you press the **RCPT** key to make a second copy.

```
26/08/96 18:10      11
123456 #1174  MEYER
          *COPY*
DPT.02              ¥8.50
3x 1.50
DPT.01              ¥4.50
CASH                ¥13.00
```

When the receipt ON-OFF function is in the "ON" status, the ***COPY*** symbol will be printed on the receipt.

2 Guest check copy

You can use this function when you want to take a copy of guest check.
Press the  key and make a desired entry.

Procedure

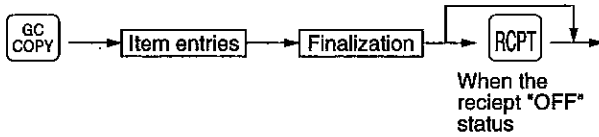

Note The guest check copy has nothing to do with the memory.

Example

Key operation

1480 



Print

G.C COPY	
DPT.01	¥14.80
CASH	¥14.80

3 Validation printing function

Your cash register can perform a validation printing.

■ Validation slip setting and printing

Insert a validation slip into the printer with its printing side downward (see the figure below), then press the **VP** key.

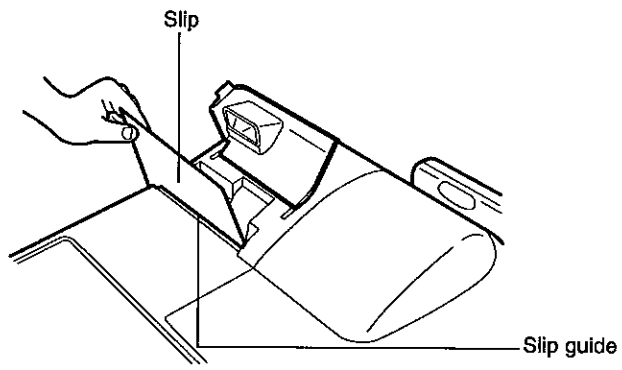

Note The validation slip may not reach the bottom of the validation slit. Insert the slip securely until it stops. A validation will correctly be printed on it.

■ Validation printing examples

Validation printing of item entries

•Department entry

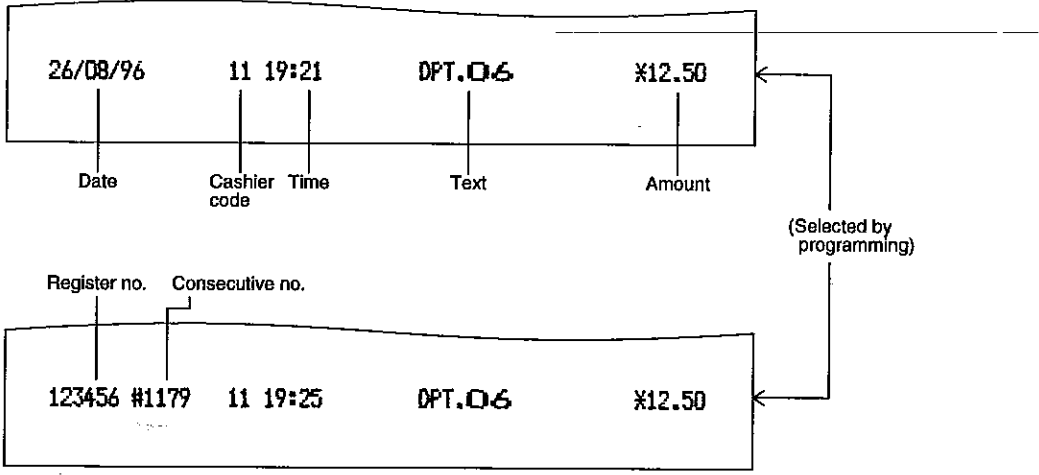

• PLU entry

26/08/96	11 19:27	PL000010	¥12.00
----------	----------	----------	--------

• Discount entry (⊖ 1 through ⊖ 4)

26/08/96	11 19:27	(-)>2	-0.65
----------	----------	-------	-------

• Refund entry

26/08/96	11 19:28	DPT.06	R-12.36
----------	----------	--------	---------

• Item percent entry (%1 through %4)

26/08/96	11 19:29	%1	-1.50
----------	----------	----	-------

• Void entry

26/08/96	11 19:30	DPT.07	#-5.00
----------	----------	--------	--------

Validation printing after the finalization of a transaction

26/08/96	11 19:23	***TOTAL	¥25.00
		Transaction symbol	Amount

TL key

- When an amount tendered entry is made
- When no amount tendered entry is made

CH through **CH4** key

- When an amount tendered entry is made
- When no amount tendered entry is made
- When a cheque cashing operation is made

CR1 through **CR4** key

RA key

RA2 key

PO key

PO2 key

Transaction symbol

***** TOTAL**
CASH or CASH2

CHECK through CHECK4

CHECK through CHECK4

CA/CHK

CREDIT through CREDIT4

***** RA**

***** RA2**

***** PO**

***** PO2**

Amount

Sales amount
Sales amount

Amount tendered

Sales amount

Amount tendered

Sales amount

Amount received on account

Amount received on account

Amount paid out

Amount paid out

Validation printing of the training mode

26/08/96	12 19:32	T	CASH	¥25.00
		Training mode symbol		

Note

- When you make an entry for which compulsory validation printing has been programmed, the "VP" lamp will light up in the display. Carry out the validation printing successively until the lamp goes off (or by the programmed number of times) while replacing validation slips. You cannot proceed to any further entry unless this printing is completed.
- Programmed compulsory validation printing can be overridden by performing the following operation. If you need this function, consult your dealer.

1. Turn the mode switch to the "MGR" position.

2. → → VP

■ Validation slip specification

Make validation slips according to the following specification. The use of any slips other than specified causes the printer to malfunction.

- Type of paper: plain paper
- Paper thickness: 0.07 to 0.14 mm thick
- Paper width: over 130 mm
- Print position

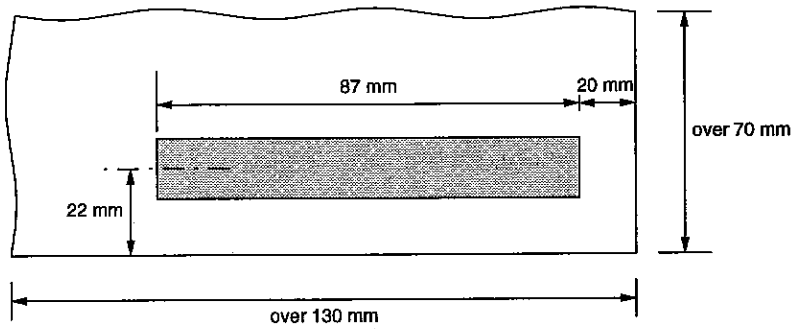

4 Printing of the employee arrival and departure times

Your cash register allows the cashier to print the employee arrival and departure times, etc. using the validation printing function.

1. Turn the mode switch to the "OP X/Z" position.
2. Put a card into the paper chute and perform the following key operation.

- Arrival time (printed on the receipt)
Numeric key 1 →
- Departure time (printed on the journal)
Numeric key 2 →

3. Sample printout

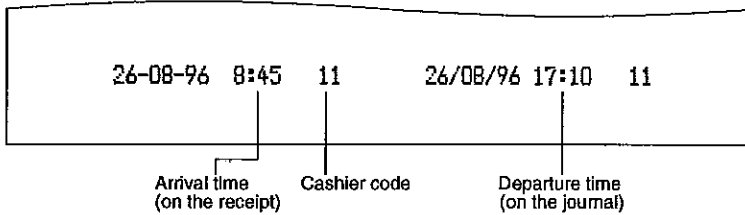

OVERLAPPED CASHIER ENTRY

This function allows you to switch from one cashier to another and to interrupt the first cashier's entry. So the second cashier can do his or her entry in this mode. For actual use of this function, contact your dealer.

Example

Cashier 1 : Entry started
 Cashier 2 : Cashier change (1 to 2), interrupt initiated
 Cashier 2 : Transaction finished (2)
 Cashier 1 : Cashier change (2 to 1), entry restarted

Note

- The overlapped cashier entry is not effective while the tendering sale is going on.
- If any cashier is still making an entry (or has not finalized the transaction yet), the machine does not run in any mode other than REG and MGR, and no X/Z reports can be printed. The message "CASHIER ERR" and the corresponding cashier number(s) is displayed at this time.

Key operation		Comments
1. Cashier 1 is assigned.	(1 <input type="button" value="CASH"/> 100 <input type="button" value="1"/> 360 <input type="button" value="3"/> <input type="button" value="3"/>	The entry by cashier 1 is started.
2. Cashier 2 is assigned.	2 <input type="button" value="CASH"/> 3 <input type="button" value="⊗"/> 150 <input type="button" value="2"/> <input type="button" value="TL"/>	The entry by cashier 2 is started. (The entry by cashier 1 is interrupted.) The transaction by cashier 2 is finalized.
3. Cashier 1 is assigned.	1 <input type="button" value="CASH"/> 100 <input type="button" value="1"/> 300 <input type="button" value="3"/> <input type="button" value="TL"/>	The entry by cashier 1 is restarted. The transaction by cashier 1 is finalized.

OPERATOR MAINTENANCE

1 In case of power failure

When power is lost, the machine retains its memory contents and all information on sales entries.

- When power failure is encountered in register idle state or during an entry, the machine returned to the normal state of operation after power recovery.
- When power failure is encountered during a printing cycle, the register prints "=====" and then carries out the correct printing procedure.
(See the sample print.)

26/08/96 19:40	11	
123456 #1189	MEVER	
DPT.01	¥10.00	Power failure symbol
DPT.02	¥5.00	
DPT.02	¥5.00	Print after power recovery
CASH	¥15.00	

2 In case of printer's motor locking

If the printer's motor happens to lock, the printing stalls, and intermittent beeping starts. You must, first of all, turn the power switch off and remove the paper jam. Then, when switched on, the following format appears in the display. "-----"

Feed the roll paper to the proper position and depress the key. The register carries out the power failure symbol and continues printing.

3 Paper roll near-end sensing function (only for journal paper) <option>

When the journal paper roll comes near the end or is not loaded, the machine senses this condition and sounds an alarm, displaying the error message "PAPER EMPTY". At this time, clear the alarm with the **CL** key and replace the paper roll as soon as possible. The following entry can be made after clearing the alarm. However, since this function works each time one transaction is completed, the alarm sound will be emitted again as the following transaction is completed unless the paper roll is replaced.

- The sensing position depends upon the size of the paper tube. Therefore, it is advisable to use paper rolls - whose paper tube is 18 mm in O.D. and 12 mm in I.D. - specified by SHARP.
- If the sensing occurs too early or late, contact your dealer.

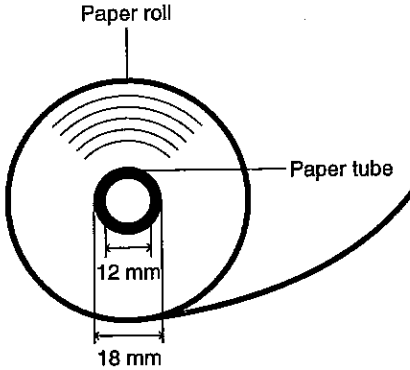

4 Installing and removing the paper roll

Install the paper roll in the printer. Be careful then to set the roll and cut the paper end correctly.

(How to set the paper roll)

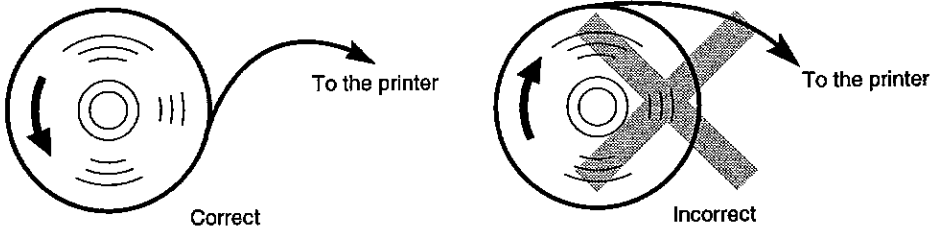

(How to cut the paper end)

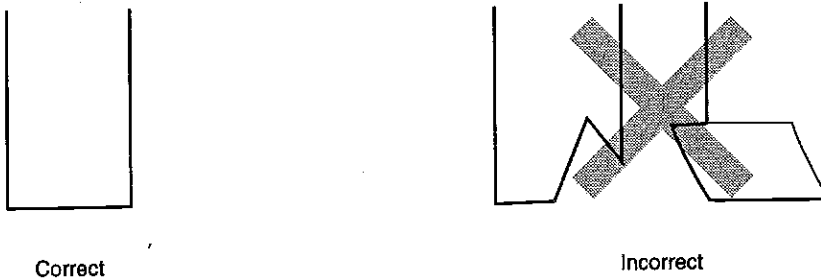

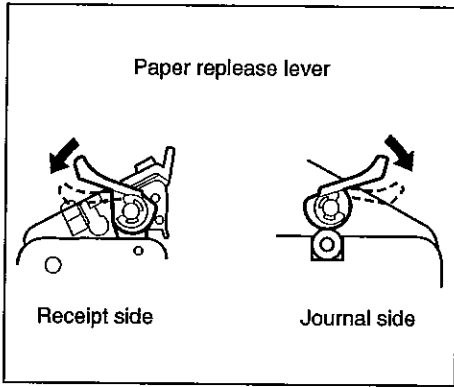

To release the paper, press the paper release lever down. It is also used for removing a paper jam. The method for removing a paper jam is described in "Removing a paper jam" later in this section.

■ Installing the paper roll

Installing the receipt paper roll

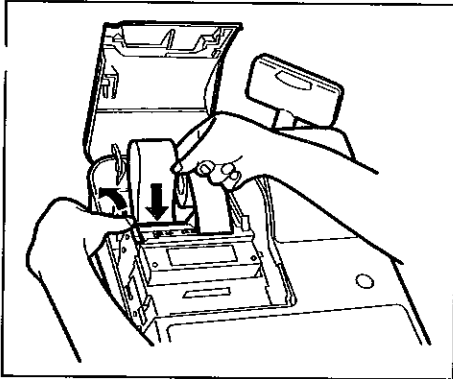

1. Open the printer cover. Set the paper roll correctly as illustrated and drop it into the printer.
2. Press the receipt paper release lever down and insert the paper end into the paper chute of the printer. Pull the paper end that has come out of the printer, holding down the lever.
3. Advance the paper by a required length by pressing the receipt paper feed key.

Installing the journal paper roll

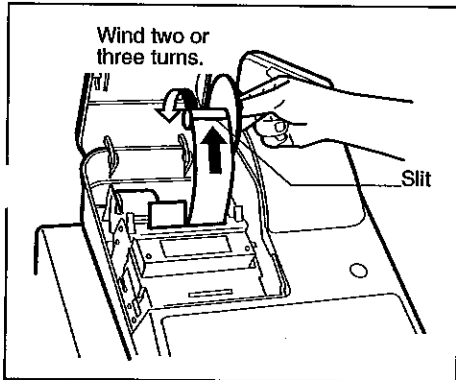

1. Open the printer cover. Set the paper roll correctly and drop it into the printer.
2. Press the journal paper release lever down, insert the paper end that has come out of the printer into the slit in the paper take-up spool, wind it two or three turns around the spool shaft, and set the spool on the bearing.

Note

Make sure the ink ribbon cassette has been mounted on the printer when installing the receipt paper roll or the journal paper roll.

■ Removing the paper roll

When a red dye appears on the paper roll, it is time to replace the existing paper roll. Replace the paper roll with a new one.

Removing the receipt paper roll

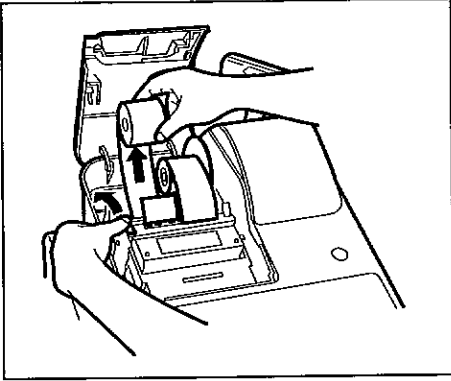

1. Open the printer cover.

2. Press and hold the receipt paper release lever down and draw out the existing paper roll from the paper roll location.

Note

Be sure to pull the roll in the direction of the arrow.

Removing the journal paper roll

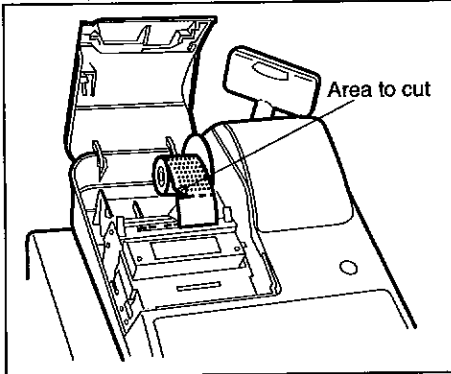

1. Press the journal paper feed key to advance the paper by several lines and then cut it.

2. Press and hold the journal paper release lever down and remove the existing paper roll from the paper roll location.

Note

Be sure to pull the roll in the direction of the arrow.

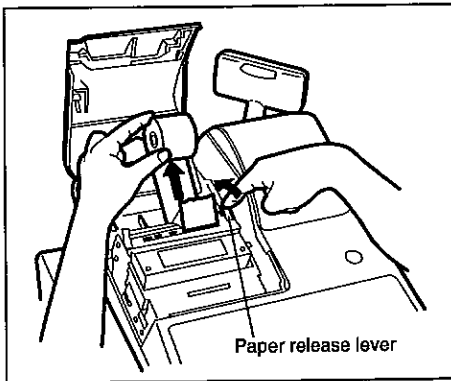

3. Remove the paper roll from the take-up spool.

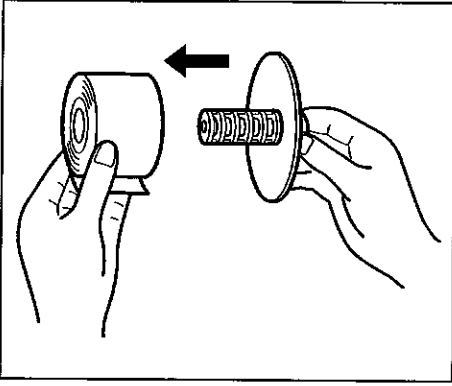

■ Removing a paper jam

1. Open the printer cover.
2. Pressing the receipt and journal paper release levers at the same time, lift part (A) up. (See the drawing below.)
3. Remove the paper jam.
4. Replace part (A) gently.
5. Reset the paper roll correctly following the steps shown in "Installing the paper roll".
6. Close the printer cover.

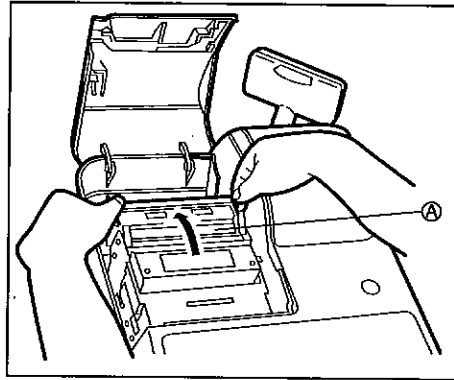
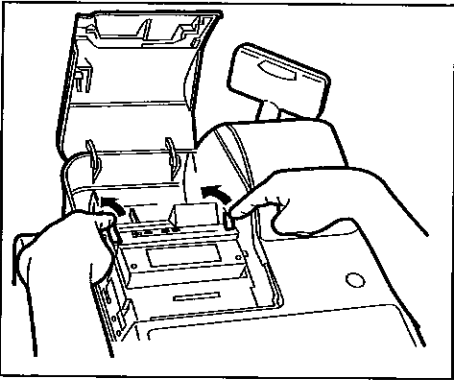

■ Recording paper specifications

Be sure to use paper rolls specified by SHARP.

The use of any other paper rolls than specified could cause paper jamming, resulting in register malfunction.

Paper specification

Paper width:	44.5 ± 0.5 mm
Max. outside diameter:	80 mm
Weight:	52.3 — 64.0 g/m ² (45 — 55 kg/1000 sheets/788 x 1091 mm ²)
Quality:	bond paper
Paper tube:	18 mm

- Be sure to set paper roll(s) prior to using your machine, otherwise it could malfunction.

5 Installing the ink ribbon cassette

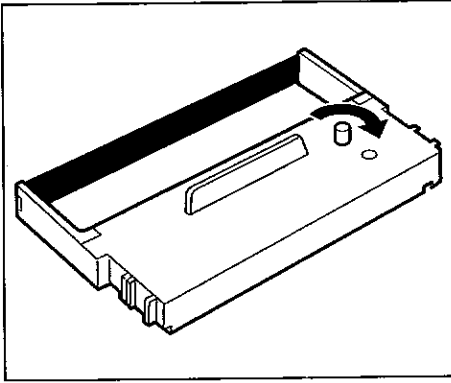

1. Open the printer cover and remove the ribbon cover.
2. Rotate the knob on the ink ribbon cassette in the direction of the arrow to stretch the ribbon tight.

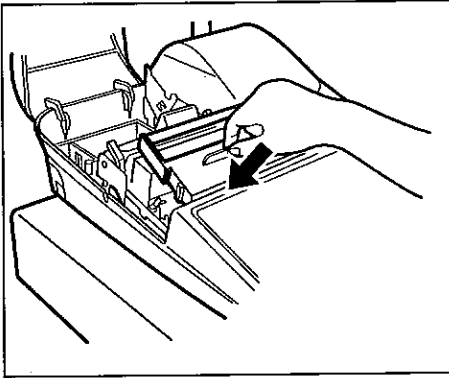

3. Put the ink ribbon cassette in the location indicated in the figure at left and fix it by using the right and left guides.
4. Rotate the knob two or three turns in the direction of the arrow to make sure it rotates smoothly. Also, make sure the ribbon is not folded.

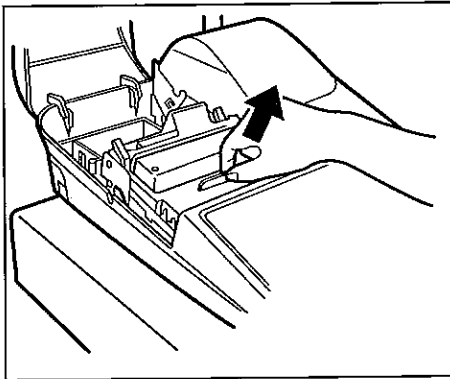

5. To remove the cassette, lift it up.

Precautions:

- Be sure to use an ink ribbon cassette specified by SHARP. The use of any ink ribbon cassettes other than specified could cause troubles in the printer.
- After opening the parcel, be careful not to make the surface of the ink ribbon dirty, and install it soon.
- Do not pour ink into the ink ribbon cassette.
- If you preserve the ink ribbon cassette for a long time, the ink will be dry and the ink ribbon cassette's life will be shortened. Please use it soon. If you do not use it soon, put it in an airtight receptacle and preserve it in a cool and dark place. Do not leave it in a location that is subject to high humidity and direct radiation.

6 Ink refill

If the logo becomes too light, refill it with the supplied logo ink following the procedure given below.

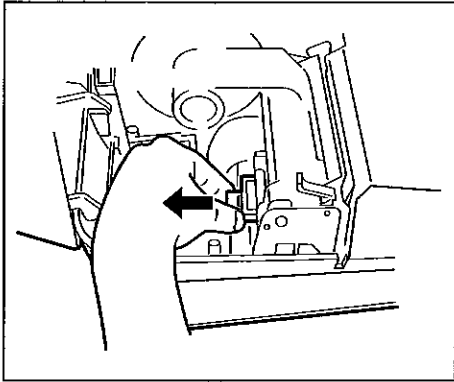

1. Open the printer cover.
2. Remove the store name logo by pulling it in the direction of the arrow.

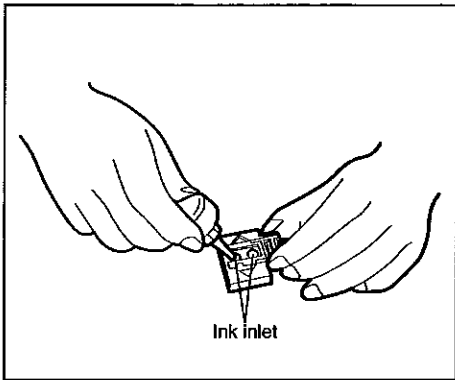

3. Pour two or three drops of logo ink through the ink inlet situated on the back of the logo.
4. Replace the logo by the reverse procedure of removing.
5. Shut the printer cover.

Precautions

- The logo ink first gives a clear print 10 to 15 hours after being poured into the logo. Therefore, refilling after the daily business is most effective.
- Overinking should be avoided. This will create a blurry print.
- The ink is exclusively used for the logo. Do not pour the ink into the ink ribbon cassette.

When the supplied ink is exhausted, purchase the logo ink specified by SHARP.

7 Removing the till and the drawer

The till in the register is detachable. After closing your business for the day remove the till from the drawer and keep the drawer open. To detach the drawer, pull it forward fully with the till removed, and remove it by lifting it up.

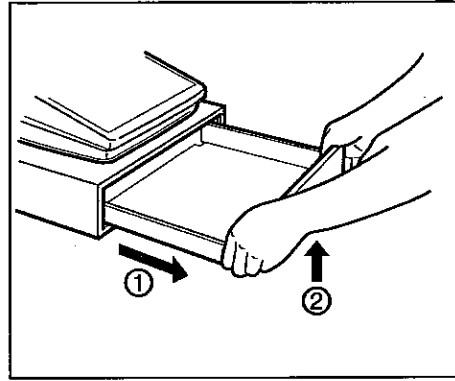
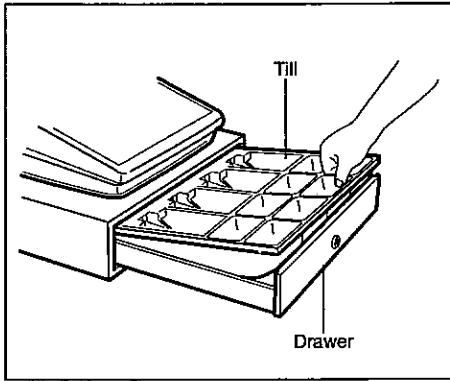

8 Opening the drawer by hand

The drawer automatically opens in the usual way, however, when power failure is encountered or the machine becomes out of order, slide the lever located on the machine bottom toward the rear. (See the figure below.) The drawer will not open, if it is locked with a drawer lock key.

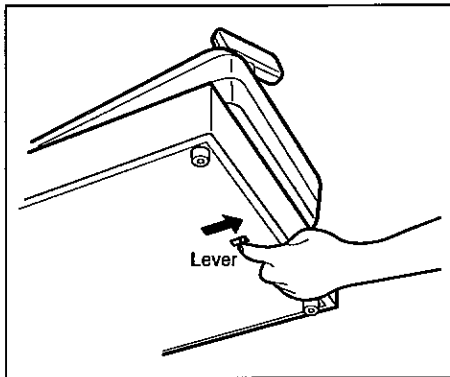

9 Before calling for service

The malfunctions shown in the left-hand column below, labeled "Fault," do not necessarily indicate functional faults of the machine. It is therefore advisable to refer to the "Checking" shown in the right-hand column before calling for service.

Fault	Checking
(1) The display won't be illuminated even when the mode switch is turned to any other position than "⏻".	<ul style="list-style-type: none">• Is power supplied to the electric outlet?• Is the power cord plug out or loosely connected to the electrical outlet?• Is the power switch in the "ON" position?
(2) The display is illuminated, but the whole machine refuses registrations.	<ul style="list-style-type: none">• Is the cashier code assigned to the register?• Is the mode switch set properly at the "REG" position?
(3) No receipt is issued.	<ul style="list-style-type: none">• Is the receipt paper roll properly installed?• Is there a paper jam?• Is the receipt ON-OFF function in the "OFF" status?
(4) No journal paper is taken up.	<ul style="list-style-type: none">• Is the take-up spool installed on the bearing properly?• Is there a paper jam?
(5) Printing is unusual.	<ul style="list-style-type: none">• Is the ink ribbon cassette installed properly?• Is the ink ribbon life completed?

10 Resetting your cash register

When the program resetting is performed, the register returns to the initial state with the memories all kept intact. If you need this function, please contact your local dealer.

Procedure

1. Set the power switch to the "OFF" position.
2. Turn the mode switch to the "PGM2" position.
3. Set the power switch to the "ON" position, keeping the receipt paper feed and journal paper feed keys depressed.

After the operation the printer prints "PRG. RESET ***" on the journal.

If the register still malfunctions even after program resetting, contact your local dealer.

LIST OF OPTIONS

For your register, the following options are available.
For details, contact your dealer.

- RAM memory chip model ER-01RA (32KB) or ER-02RA (128KB)
- RS232 interface model ER-A5RS
- RS232 control ROM model ER-A46R1
- Programming remote keyboard ER-01RK
- Real cashier key switch model ER-A5CL
- Till model ER-48CC2 and till cover model ER-01CV1/CV2/CV3/CV4/CV5
- Key kits (for ER-A460 only)

By using the following key kits, you can change the keyboard layout of your register including the expansion of the number of departments.

ER-11KT7: 30 regular size key kits

ER-12KT7: 30 1 x 2 size key kits

ER-22KT7: 10 2 x 2 size key kits

ER-11DK7: 30 regular size dummy key kits

ER-51DK7: 10 5 x 1 size dummy key kits

SPECIFICATIONS

Model:	ER-A460/A470																																																	
Dimensions:	421(W) x 448(D) x 360(H) mm 421(W) x 448(D) x 302(H) mm (Projection not included)																																																	
Weight:	13.4 kg																																																	
Power source:	Official (nominal) voltage and frequency																																																	
Power consumption:	Stand-by 14W Operating 44W (max.) (230-240V) 42W (max.) (220-230V)																																																	
Working temperature:	0 °C to 40 °C																																																	
Electronics:	LSI (CPU), etc.																																																	
Built-in battery:	Ni-Cd rechargeable battery, memory holding time about 1 month (with fully charged built-in battery, at room temperature)																																																	
Display:	Operator display (upper): Dot-matrix display (12 positions) Operator display (lower): 7-segment display (10 positions) Customer display: 7-segment display (7 positions)																																																	
Printer:	Type: 2-station serial dot-matrix (7 x 7 font) printer Printing capacity: 24 digits each for receipt and journal paper Other functions: <ul style="list-style-type: none"> • Logo message function • Receipt ON-OFF function, journal selective function • Receipt and journal independent paper feed function • Validation printing function 																																																	
Ink ribbon: (Cassette type)	Color: Purple (single color) Width: 13 mm Length: 9 meters																																																	
Logo:	Dimensions of the printing face: 30(W) X 20(H) mm																																																	
Paper roll:	Width: 44.5 ± 0.5 mm Max. diam.: 80 mm Weight: 52.3 - 64.0 g/m ² (bond paper)																																																	
Cash drawer:	4 slots for bill and 8 for coin denominations																																																	
Accessories:	<table border="0" style="width: 100%;"> <tr> <td>Manager key</td> <td style="text-align: right;">2</td> <td></td> </tr> <tr> <td>Submanager key</td> <td style="text-align: right;">2</td> <td></td> </tr> <tr> <td>Operator key</td> <td style="text-align: right;">2</td> <td></td> </tr> <tr> <td>Drawer lock key</td> <td style="text-align: right;">2</td> <td></td> </tr> <tr> <td>Printer cover lock key</td> <td style="text-align: right;">2</td> <td></td> </tr> <tr> <td>Ink ribbon cassette</td> <td style="text-align: right;">1</td> <td></td> </tr> <tr> <td>Standard logo</td> <td style="text-align: right;">1</td> <td>(mounted on the printer)</td> </tr> <tr> <td>Logo ink</td> <td style="text-align: right;">1</td> <td>(5cc)</td> </tr> <tr> <td>Paper roll</td> <td style="text-align: right;">2</td> <td></td> </tr> <tr> <td>Spool</td> <td style="text-align: right;">1</td> <td></td> </tr> <tr> <td>Bill separator</td> <td style="text-align: right;">1</td> <td></td> </tr> <tr> <td>Instruction manual</td> <td style="text-align: right;">1</td> <td>copy</td> </tr> <tr> <td>Easy programming instruction manual</td> <td style="text-align: right;">1</td> <td>copy</td> </tr> <tr> <td>Standard key sheet</td> <td style="text-align: right;">1</td> <td>(mounted on the keyboard)</td> </tr> <tr> <td>Programming key sheet</td> <td style="text-align: right;">1</td> <td>(mounted on the keyboard)</td> </tr> <tr> <td>Blank key sheet</td> <td style="text-align: right;">1</td> <td>(mounted on the keyboard)</td> </tr> </table>		Manager key	2		Submanager key	2		Operator key	2		Drawer lock key	2		Printer cover lock key	2		Ink ribbon cassette	1		Standard logo	1	(mounted on the printer)	Logo ink	1	(5cc)	Paper roll	2		Spool	1		Bill separator	1		Instruction manual	1	copy	Easy programming instruction manual	1	copy	Standard key sheet	1	(mounted on the keyboard)	Programming key sheet	1	(mounted on the keyboard)	Blank key sheet	1	(mounted on the keyboard)
Manager key	2																																																	
Submanager key	2																																																	
Operator key	2																																																	
Drawer lock key	2																																																	
Printer cover lock key	2																																																	
Ink ribbon cassette	1																																																	
Standard logo	1	(mounted on the printer)																																																
Logo ink	1	(5cc)																																																
Paper roll	2																																																	
Spool	1																																																	
Bill separator	1																																																	
Instruction manual	1	copy																																																
Easy programming instruction manual	1	copy																																																
Standard key sheet	1	(mounted on the keyboard)																																																
Programming key sheet	1	(mounted on the keyboard)																																																
Blank key sheet	1	(mounted on the keyboard)																																																

} for
ER-A470
only

* Specifications and appearance subject to change without notice for improvement.

PROGRAMMING REMOTE KEYBOARD (OPTION) MODEL ER-01RK

1 External view

Front View

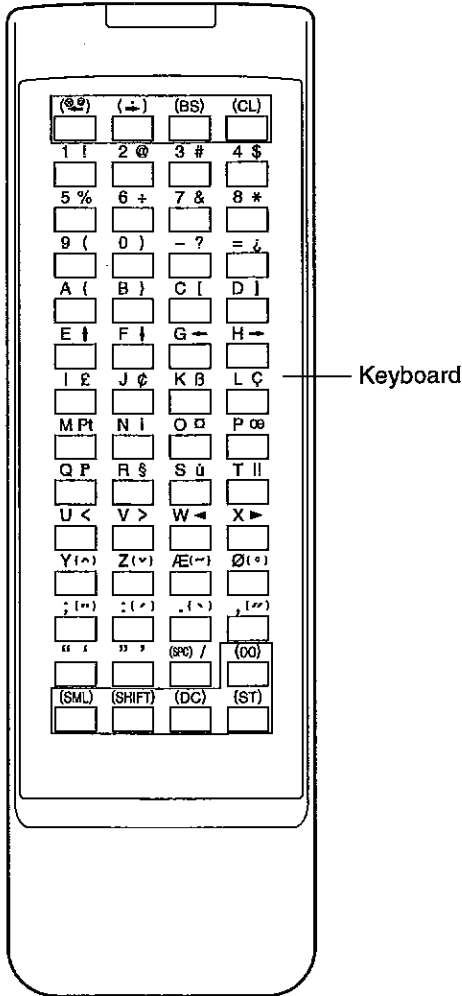

Rear View

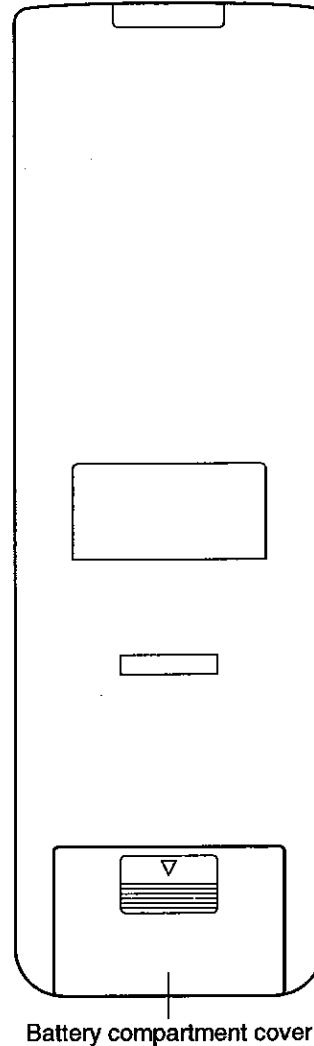

2 Precautions

Keep the following precautions when using the programming remote keyboard:

- Never let any liquid such as water and a chemical agent on the programming remote keyboard. Or it may cause malfunction.
- Never drop the programming remote keyboard nor subject it to severe impact or extreme force.

3 Installing AAA batteries

Before using the programming remote keyboard, purchase and install two AAA batteries.

Caution To protect an explosion, a failure or a leakage of the AAA battery:

- do not use batteries of different types.
- do not use a new AAA battery with an old one.
- do not short out the AAA battery.
- do not disassemble the AAA battery.
- make sure that the polarity of the AAA battery is correct.
- avoid mixing a spent AAA battery into combustible waste.
- avoid burning a spent AAA battery.

To install them, do the following:

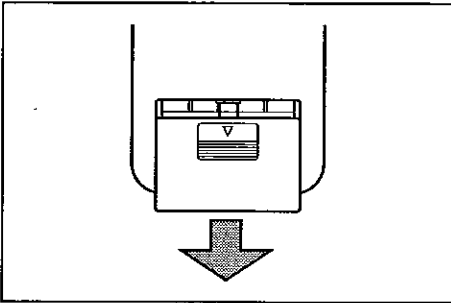

1. Open the battery compartment cover.

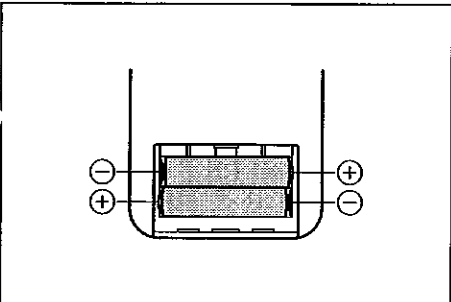

2. Install the AAA batteries. Check the polarity of them.

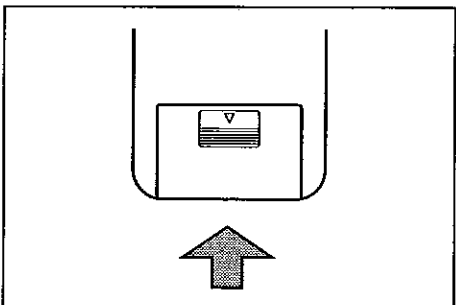

3. Close the battery compartment cover.

4 Programming

The ER-01RK is a useful part for programming by remote control. With this programming remote keyboard, you can program alphanumeric characters, unit prices for departments and PLUs, functions and so on.

This programming remote keyboard changes its function according to the current mode: the normal mode or the character entry mode. In the normal mode, it functions as a numeric keypad. The keys surrounded with dashed line boxes in the following figure are available. In the character entry mode, it functions as character keys. All the keys excepting the **[00]** key are available.

Note

When entering a character, the programming remote keyboard should be directed to the sensor on the top of the customer display. The distance should be within 80 cm.

Keyboard layout of ER-01RK

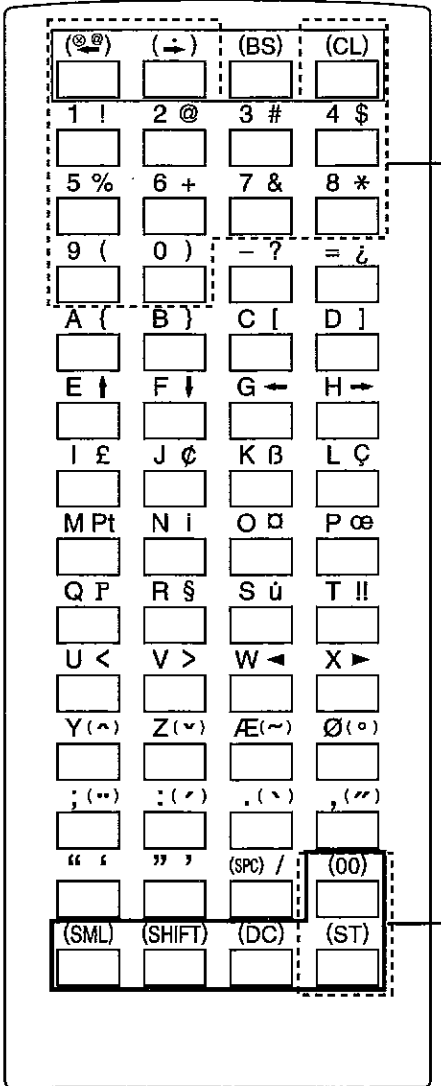

Available keys for the normal mode

Note

The following key marks show the following functions:

Keys	Used as:	
	Normal mode	Character entry mode
[⊙⊙]	⊙ key	Left cursor key
[→]	→ key	Right cursor key
[BS]	—	Back space key
[CL]	Clear key	Clear key
[1 !]	Numeric keypad	Character keys
[2 @]		
[3 #]		
[4 \$]		
[5 %]		
[6 +]		
[7 &]		
[8 *]		
[9 (]	A space key or the character key (" ")	
[0)]		
[SPC /]	—	
[00]	[00] key. It is used to go into the character entry mode.	—
[SML]	—	used for entering letters in lower case.
[SHIFT]	—	used for entering the right side letter.
[DC]	—	used for entering characters in double size.
[ST]	[ST] key	[ST] key

■ General instructions for programming alphanumeric characters using the ER-01RK

This programming remote keyboard allows you to program various items instead of using the keyboard of the cash register.

The basic instruction for programming with the remote keyboard is the same as the one with the keyboard of the register. In this part, the method for programming alphanumeric characters is described.

Note Both PGM1 and PGM2 modes are available for this programming.

Procedure

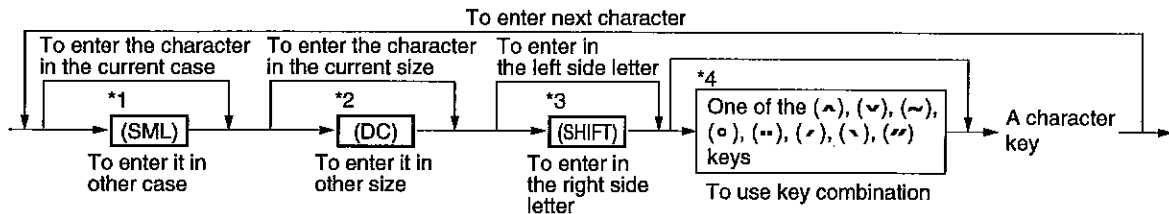

*1 Letters of alphabets "A" through "Z" are possible to be entered in lower case or in upper case. **By default, the upper-case letter mode is selected.** To enter the character in lower case, press the (SML) key before you enter the character. The SML lamp lights up. To return to the upper-case letter mode, press the (SML) key again.

Example To enter "aA", do the following:

(SML) → A { → (SML) → A {

*2 Characters are possible to be entered in single size or in double size. **By default, the single-size character mode is selected.** To enter the character in double size, press the (DC) key before you enter the character. The DC lamp lights up. To return to the single-size character mode, press the (DC) key again.

Example To enter "aAA", do the following:

(SML) → (DC) → A { → (SML) → A { → (DC) → A {

*3 Each character key has two levels. For example, with the A { key, you can enter "A" or "[". **Under the normal condition, the left side letter is selected.** To use the right side letter, press the (SHIFT) key just before you press a key.

Example To enter "Aa[" do the following:

A { → (SML) → A { → (SHIFT) → C [

*4 "(^)", "(v)", "(~)", "(o)", "(--)", "(/)", "(v)", and "(/)" are used only for combination with a character key. If the combination is unavailable, only a character key is entered.

Example

To enter "Ä", do the following:

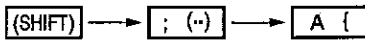

To enter "ä", do the following:

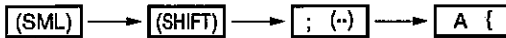

Example

Programming "Soup [A]" for department 15

Key operation			Print
2 @	1 !	1 !	<div style="border: 1px solid black; padding: 5px;"> <p>#2114 XFGM2X</p> <p>D15 1.00</p> <p>Soup [A] 600</p> <p>0000003 L17</p> </div>
4 \$	(→)	(⊗)	
1 !	5 %	(⊗)	
S ũ			
(SML) O □			
U <			
P œ			
(SPC) /			
(SHIFT) C [
(SML) A {			
(SHIFT) D]			
(ST)			
TL			

← for completing job no.

← for selecting dept. 15

← for character "S"

← for character "o"

← for character "u"

← for character "p"

← for a space

← for character "["

← for character "A"

← for character "]"

← to finalize entering character

Operation with the keyboard on the cash register

Operation with the programming remote keyboard

