

SHARP®

ELECTRONIC CASH REGISTER

MODEL

ER-A450

INSTRUCTION MANUAL



CAUTION:

The cash register and the remote drawer should be securely fitted to the supporting platforms to avoid instability when the drawers are open.

CAUTION:

The socket-outlet shall be installed near the equipment and shall be easily accessible.

VORSICHT:

Die Netzsteckdose muß nahe dem Gerät angebracht und leicht zugänglich sein.

ATTENTION:

La prise de courant murale devra être installée à proximité de l'équipement et devra être facilement accessible.

AVISO:

El tomacorriente debe estar instalado cerca del equipo y debe quedar bien accesible.

VARNING:

Det matande vägguttaget skall placeras nära apparaten och vara lätt åtkomligt.

CAUTION:

For a complete electrical disconnection pull out the mains plug.

VORSICHT:

Zur vollständigen elektrischen Trennung vom Netz den Netzstecker ziehen.

ATTENTION:

Pour obtenir une mise hors-circuit totale, débrancher la prise de courant secteur.

AVISO:

Para una desconexión eléctrica completa, desenchufar el enchufe de tomacorriente.

VARNING:

För att helt koppla från strömmen, dra ut stickproppen.

This equipment complies with the requirements of Directives 89/336/EEC and 73/23/EEC as amended by 93/68/EEC.

Dieses Gerät entspricht den Anforderungen der EG-Richtlinien 89/336/EWG und 73/23/EWG mit Änderung 93/68/EWG.

Ce matériel répond aux exigences contenues dans les directives 89/336/CEE et 73/23/CEE modifiées par la directive 93/68/CEE.

Dit apparaat voldoet aan de eisen van de richtlijnen 89/336/EEG en 73/23/EEG, gewijzigd door 93/68/EEG.

Dette udstyr overholder kravene i direktiv nr. 89/336/EEC og 73/23/EEC med tillæg nr. 93/68/EEC.

Quest' apparecchio è conforme ai requisiti delle direttive 89/336/EEC e 73/23/EEC, come emendata dalla direttiva 93/68/EEC.

Η εγκατάσταση αυτή ανταποκρίνεται στις απαιτήσεις των οδηγιών της Ευρωπαϊκής Ένωσης 89/336/ΕΟΚ και 73/23/ΕΟΚ, όπως οι κανονισμοί αυτοί συμπληρώθηκαν από την οδηγία 93/68/ΕΟΚ.

Este equipamento obedece às exigências das directivas 89/336/CEE e 73/23/CEE, na sua versão corrigida pela directiva 93/68/CEE.

Este aparato satisface las exigencias de las Directivas 89/336/CEE y 73/23/CEE, modificadas por medio de la 93/68/CEE.

Denna utrustning uppfyller kraven enligt riktlinjerna 89/336/EEC och 73/23/EEC så som kompletterade av 93/68/EEC.

Dette produktet oppfyller betingelsene i direktivene 89/336/EEC og 73/23/EEC i endringen 93/68/EEC.

Tämä laite täyttää direktiivien 89/336/EEC ja 73/23/EEC vaatimukset, joita on muutettu direktiivillä 93/68/EEC.

INTRODUCTION

Thank you very much for your purchase of the SHARP Electronic Cash Register, Model ER-A450.

Please read this Manual carefully before operating your machine in order to gain full understanding of functions and features.

Please keep this manual for future reference, it will help you, if you encounter any operational problems.

IMPORTANT

- **Install your register in a location that is not subject to direct radiation, unusual temperature changes, high humidity or exposed to water sources.**
Installation in such locations could cause damage to the cabinet and the electronic components.
- **The register should not be operated by an individual with wet hands.**
The water could seep into the interior of the register and cause component failure.
- **When cleaning your register, use a dry, soft cloth. Never use solvents, such as benzine and/or thinner.**
The use of such chemicals will lead to discoloration or deterioration of the cabinet.
- **The register plugs into any standard wall outlet (Official (nominal) voltage).**
Other electrical devices on the same electrical circuit could cause the register to malfunction.
- **If the register malfunctions, call your local dealer for service - do not try to repair the register yourself.**
- **For a complete electrical disconnection, pull out the mains plug.**

PRECAUTION

This Electronic Cash Register has a built-in memory protection circuit which is operated by rechargeable batteries.

As you know, all batteries will, in time, dissipate their charge even if not used. Therefore to insure an adequate initial charge in the protection circuit, and to prevent any possible loss of memory upon installation, it is recommended that each unit be allowed to recharge for a period of 24 to 48 hours prior to use by the customer. In order to charge the batteries, the machine must be plugged in. This recharging precaution can prevent unnecessary initial service calls.

CONTENTS

INTRODUCTION.....	1
IMPORTANT.....	1
PRECAUTION.....	1
CONTENTS.....	2
EXTERNAL VIEW	6
Front view.....	6
Rear view.....	6
PRINTER	7
KEYBOARD	8
1 Standard keyboard layout.....	8
2 Standard key number layout.....	9
KEYS AND SWITCHES	10
1 Mode switch and mode keys.....	10
2 Drawer lock key.....	10
DISPLAYS	11
Machine state symbols.....	11

FOR THE MANAGER

PRIOR TO PROGRAMMING	12
1 General instructions.....	12
2 How to program alphanumeric characters.....	12
Using character keys on the keyboard.....	12
Entering character codes.....	13
PROGRAMMING	15
Preparations for Programming.....	15
Direct Programming	15
1 Setting the date and time.....	15
Date.....	15
Time.....	16
2 Programming for departments.....	16
Unit price.....	16
Functional selection.....	17
3 Price lookup (PLU) programming.....	19
Unit price.....	19
Functional selection.....	19
PLU assignment to departments.....	21
4 Programming for discount keys.....	22
Deduction amount (⊖).....	22
High amount lockout (HALO) and +/- sign (⊖).....	23
5 Programming for percent keys.....	24
Percent rate (%).....	24
Sign (+/-) (%).....	24
6 Programming for exchange keys.....	25
Currency exchange rate (EX).....	25
7 Programming for the CA2, RA, PO, CH and CR keys.....	25
High amount lockout (HALO) (CA2, RA, PO, CH, and CR).....	25
8 Programming the tax rate.....	26
Tax rate.....	26

Job-Code-Based Programming	27
1 Setting the date and time.....	27
Setting the date (#2610).....	27
Setting the time (#2611).....	27
2 Setting the register and consecutive numbers	28
Setting the register number (#2612).....	28
Setting the consecutive number (#2613).....	28
3 Programming the tax rate	29
The tax rate (#2711).....	29
4 Programming for departments.....	30
Functional programming (#2110)	30
Tax status (#2111).....	31
A limit amount (HALO) of entry (#2112)	32
Alphanumeric characters (#2114)	33
Unit price (#1110).....	33
Commission group assignment (#2115).....	34
Group number (#2116).....	34
Department key positioning (#2119).....	35
5 Price lookup (PLU) programming	36
Department assignment (#1200, 2230)	37
Unit prices (#1210)	38
Base quantity (#1211)	38
PLU/subdepartment mode (#2210, 2231)	39
Sign (+/-) and tax status (#2211, 2232).....	40
Alphanumeric characters (#2214)	41
Assigning of PLUs to commission groups (#2215, 2235).....	42
Link PLU (#2220).....	43
Direct PLU key positioning (#2219).....	43
6 Programming for miscellaneous keys.....	44
Programming the rate (<input type="checkbox"/> , <input type="checkbox"/> EX, commission) and the deduction (<input type="checkbox"/>) (#1310).....	44
A limit amount (HALO) of entry (<input type="checkbox"/> , <input type="checkbox"/> RA, <input type="checkbox"/> PO) (#2312).....	45
+/- sign (<input type="checkbox"/> , <input type="checkbox"/>) (#2311)	46
Item % or subtotal % selection (<input type="checkbox"/>) (#2315).....	47
Percent rate limitation (<input type="checkbox"/>) (#2313).....	47
Item <input type="checkbox"/> or subtotal <input type="checkbox"/> selection (<input type="checkbox"/>) (#2316)	48
7 Programming for the (<input type="checkbox"/> TL, <input type="checkbox"/> CA2, <input type="checkbox"/> CH1) through <input type="checkbox"/> CH4, and <input type="checkbox"/> CR1) through <input type="checkbox"/> CR4) keys.....	49
Functional programming (#2320)	49
High amount lockout (HALO) for cheque change, cheque cashing, and cash in drawer (#2321).....	50
High amount lockout (HALO) of entry for media keys (#2322).....	50
8 Programming of function text.....	51
Programming (#2314).....	51
List of function texts.....	52
9 Cashier and clerk programming	53
Cashier code (#1500).....	53
Cashier name (#1514).....	54
Functional programming for cashiers (#2510).....	54
Clerk code (#1400).....	55
Clerk name (#1414).....	55
10 Programming various functions	56
Programming for optional feature selection (#2616)	56
Programming feed line after printing of a difference subtotal (#2615).....	59
Programming alarm length of time with drawer opening (#2617).....	59
Programming of logo messages (#2614)	60
Selection of X1/Z1 and X2/Z2 reports to be printed in the stacked report sequence (#2620).....	61
Setting the time range for hourly reports (#2619).....	62
RS-232C channel assignment (#2690)	62

Secret codes to control access to the PGM1 mode, X1/Z1 mode and X2/Z2 mode (#2630, 2631, 2632)	63
Currency description text programming (#2334)	63
Functional programming for the printer (#2990)	64
Assigning the drawer number to the drawer for foreign currency (#2680)	64
Setting the AUTO key - Automatic sequencing key - (#2900)	65
11 Reading stored programs	66
Program details and procedures for their reading	66
Sample printouts	67
12 Training mode	72
READING (X) AND RESETTING (Z) OF SALES TOTALS	73
1 Summary of reading (X) and resetting (Z) reports and the key operations to obtain the reports	73
2 Automatic modification of register system for introduction of EURO	75
3 Daily sales totals	76
Full reading and resetting of sales totals	76
Cashier reading and resetting	79
Clerk reading and resetting	80
Reading and resetting of hourly sales information	81
Full department reading	82
Individual group reading	83
Full group reading	83
Reading and resetting of sales information for a range of PLUs/subdepartments	84
Reading of sales information on PLUs/subdepartments associated with an individual department	85
Reading of sales information on PLUs/subdepartments whose sales amounts are zeros	85
Reading of sales information for the price amount range of PLUs/subdepartments	85
Reading of commission sales information	85
Transaction reading	86
Total in drawer reading	86
Reading and resetting of a stacked report	86
4 Periodic consolidation	87
Generality	87
Reading and resetting of daily net totals	88
Reading and resetting of a stacked report	88
COMPULSORY CASH/CHEQUE DECLARATION	89
OVERRIDE ENTRIES	91
CORRECTION AFTER FINALIZING A TRANSACTION (AFTER GENERATING A RECEIPT)	92

FOR THE OPERATOR

PRIOR TO ENTRIES	93
1 Preparations for entries	93
Receipt and journal paper rolls	93
Receipt ON/OFF function	93
Cashier and clerk assignment	93
2 Error warning	94
ENTRIES	95
1 Item entries	95
Single item entries	95
Repeat entries	96
Multiplication entries	96
Successive multiplication entries	97
Split-pricing entries	98
Single item cash sale (SICS)/single item finalize (SIF) entries	99
Link PLU entries	99
2 Displaying subtotals	100
Normal subtotal	100

Difference subtotal (Differ ST)	100
3 Finalization of transaction	101
Cash or cheque tendering	101
Mixed tendering (cheque + cash)	101
Cash or cheque sale that does not need any tender entry	101
Credit sale	102
Mixed-tender sale (cash or cheque tendering + credit tendering)	102
4 Computation of VAT (Value Added Tax)/tax	102
VAT/tax system	102
VAT shift entries	104
5 Auxiliary entries	104
Percent calculations (premium or discount)	104
Deduction entries	105
Refund entries	106
Printing of non-add code numbers	106
6 Payment treatment	106
Currency exchange	106
Received on account entries	107
Paid out entries	107
No sale (exchange)	108
Cashing a cheque	108
7 Automatic sequencing key (AUTO key) entries	108
CORRECTION	109
1 Correction of the last entry (direct void)	109
2 Correction of the next-to-last or earlier entries (indirect void)	109
3 Subtotal void	110
4 Correction of incorrect entries not handled by the direct or indirect void function	110
SPECIAL PRINTING FUNCTIONS	111
1 Copy receipt printing	111
2 Guest check copy	112
3 Printing of header and footer graphic logos	112
OVERLAPPED CASHIER ENTRY	113
OPERATOR MAINTENANCE	114
1 In case of power failure	114
2 In case of printer error	114
3 Thermal printing	114
Cautions in handling the printer	114
Cautions in handling the recording paper (thermal paper)	115
4 Paper roll near-end sensing function (only for the journal paper) <option>	115
5 Installing and removing the paper roll	116
Recording paper specifications	116
Installing the paper roll	116
Removing the paper roll	118
Removing a paper jam	119
6 Cleaning the print head	120
7 Removing the till and the drawer	121
8 Opening the drawer by hand	121
9 Installing the fixing angle bracket	122
10 Before calling for service	123
Error code table	123
LIST OF OPTIONS	124
SPECIFICATIONS	125

EXTERNAL VIEW

■ Front view

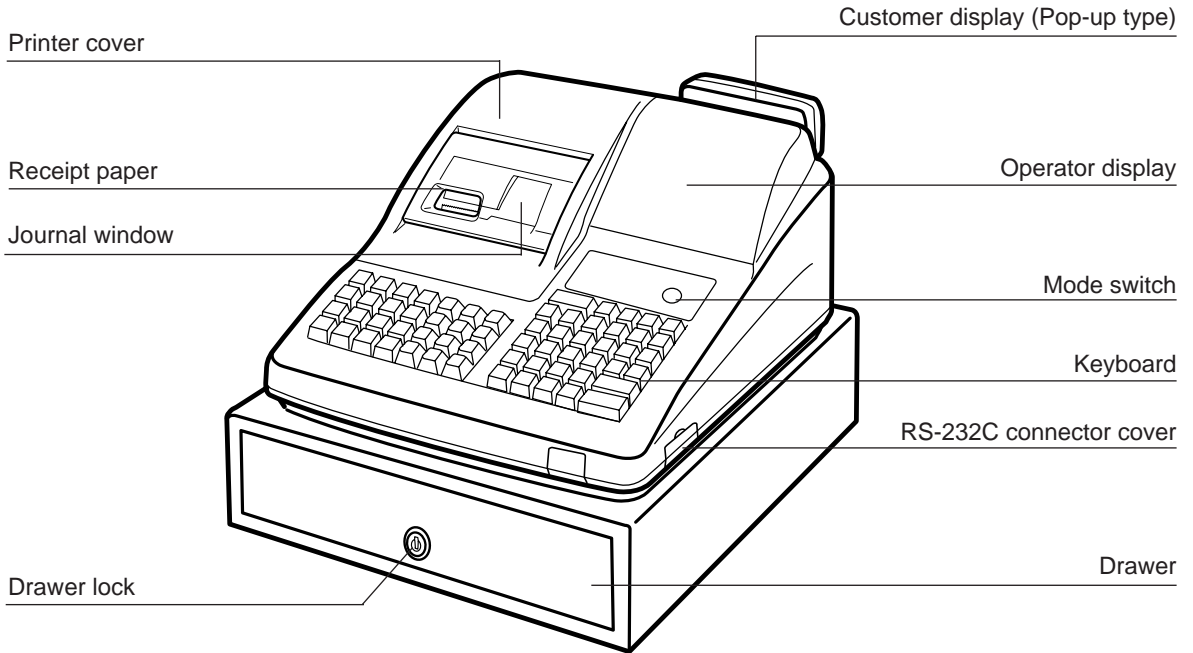

■ Rear view

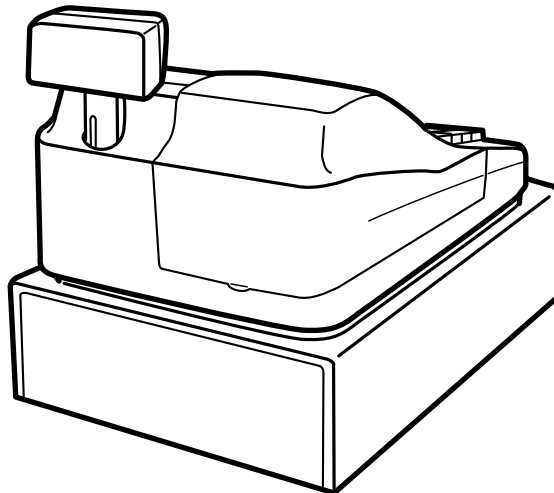

PRINTER

The printer is a receipt/journal dual station type thermal printer, and therefore it does not require any type of ink ribbon or cartridge. The average life of the printer is approximately 5 million lines.

When removing the printer cover, lift up its rear. When installing the printer cover, hook it on the pawls on the cabinet and shut it.

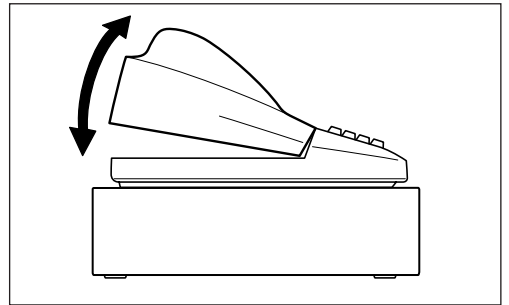

Your register is shipped with the print head release lever held by a white retainer in the lifted up position. Be sure to remove this retainer (see the figure at the right) and push down the print head release lever before you use the register.

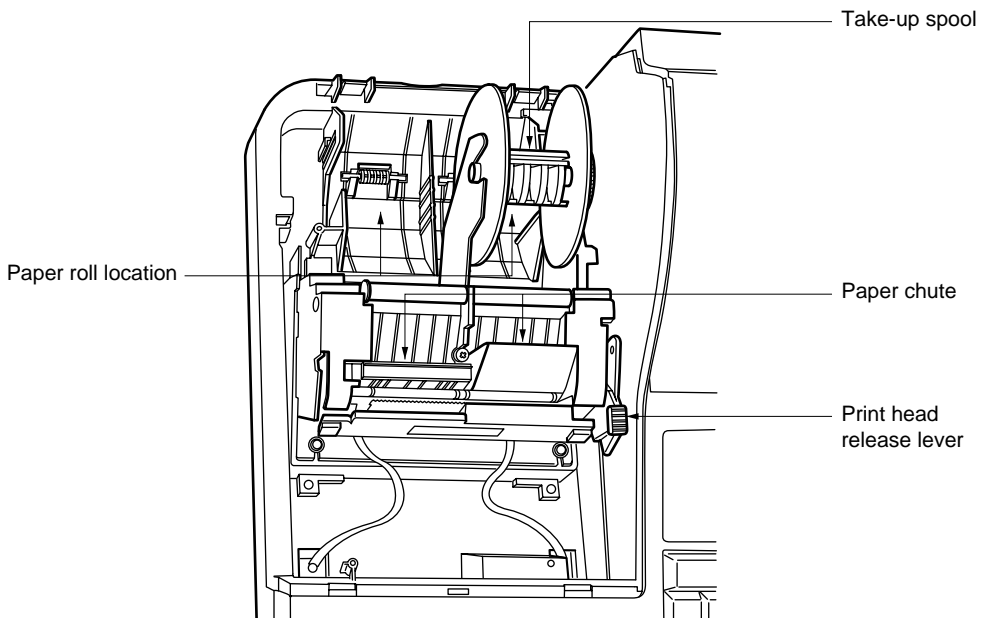
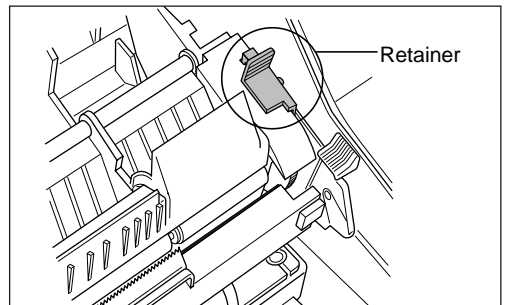

Print head release lever

The print head can be lifted by the green lever on the right side of the printer. Pulling the lever forward lifts the print head up. If the paper becomes jammed and you need to move the head farther forward, you can pull the lever even further toward you and proceed with the removal of the jammed paper.

Note

Do not attempt to remove the paper roll with the head in the down position. This may result in damage to the printer and print head.

KEYBOARD

1 Standard keyboard layout

↑ RECEIPT	↑ JOURNAL	#	CL	7	8	9
RCPT	⊖	NS	⊗	4	5	6
%1	PO	RA	AUTO 1	1	2	3
%2	RF	∞	AUTO 2	0	00	•

PLU/SUB	AMT	VAT	EX1	CASH #
5	10	15	20	EX2
4	9	14	19	CR1
3	8	13	18	CH1
2	7	12	17	ST
1	6	11	16	TL

Note

All the keys but the receipt paper feed and journal paper feed keys can be re-positioned. If you want to change the layout, consult your dealer.



Receipt paper feed key



Journal paper feed key



Numeric keys

Decimal point key

Multiplication/split-pricing key

Clear key

Department keys

Price lookup/subdepartment key

Amount entry key



Value added tax key



Non-add code key



Cashier code entry key



Receipt print key



Discount key



Automatic sequencing 1 and 2 keys



Percent 1 and 2 keys



No-sale key



Received-on-account key



Paid-out key



Refund key



Void key

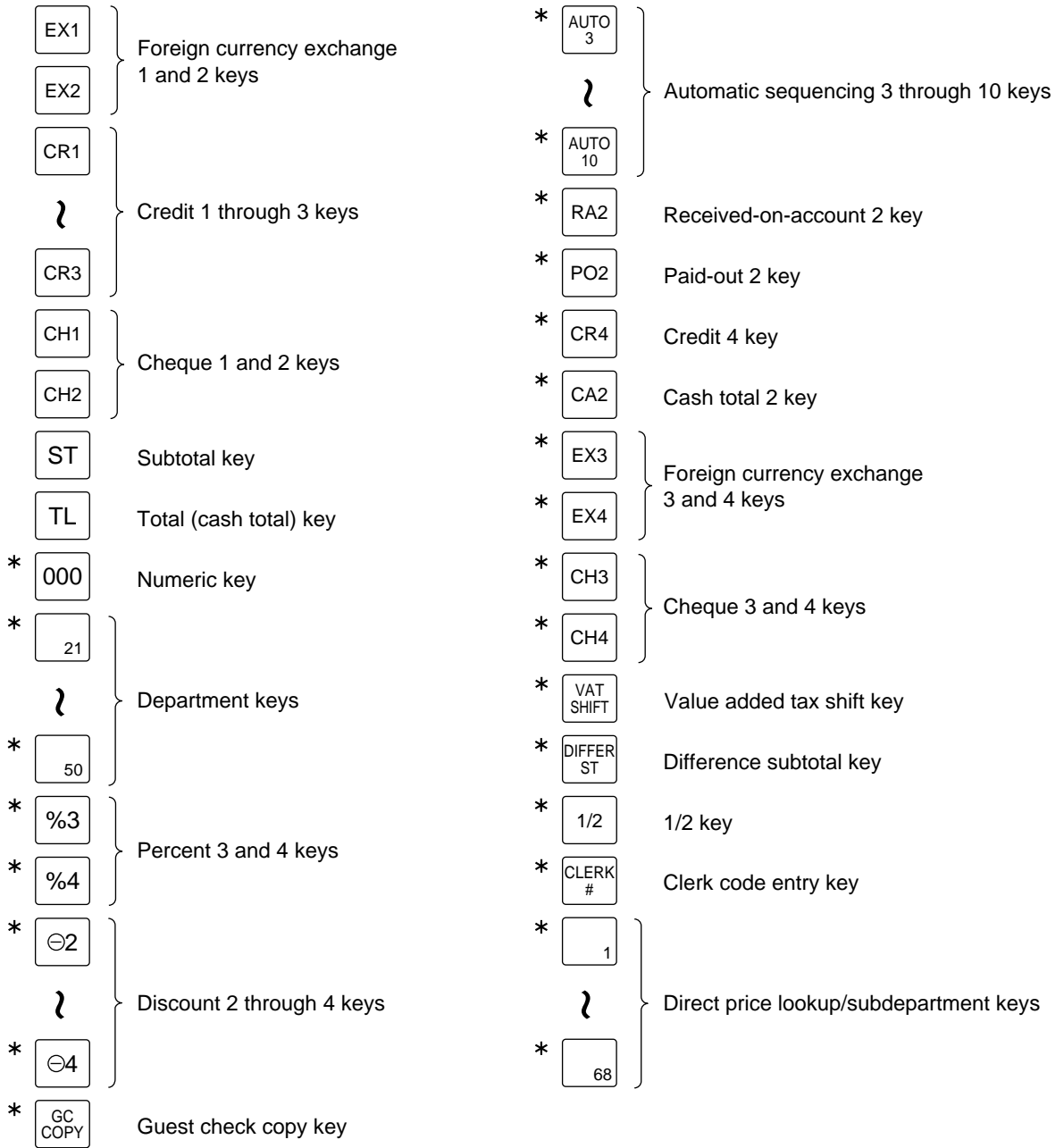

Note The standard keyboard is not equipped with those keys that are marked with (*).

2 Standard key number layout

These key numbers are used for positioning of department keys and direct PLU keys. Refer to pages 35 and 43. This layout can be changed by your dealer.

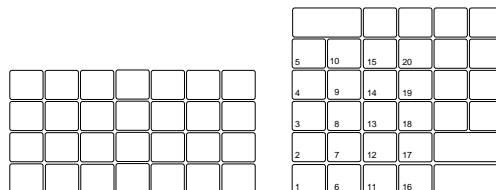

KEYS AND SWITCHES

1 Mode switch and mode keys

The mode switch can be operated by inserting one of the three supplied mode keys - manager (MA), submanager (SM), and operator (OP) keys. These keys can be inserted or removed only when the switch is in the "REG" or "⏻" position.

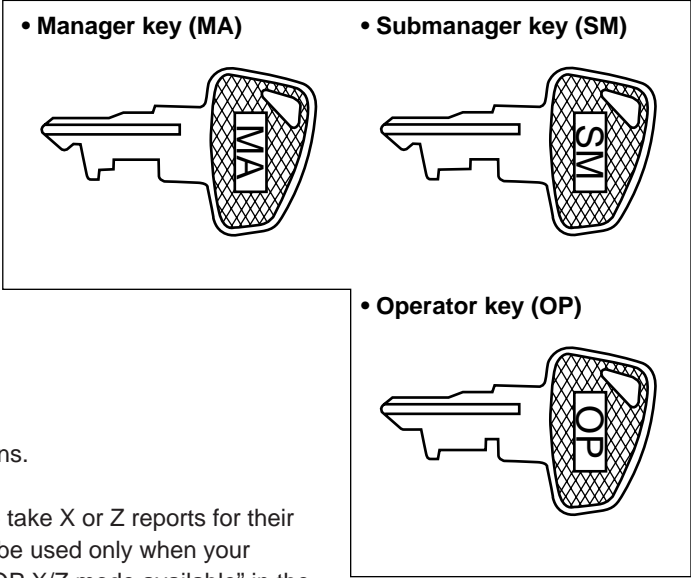
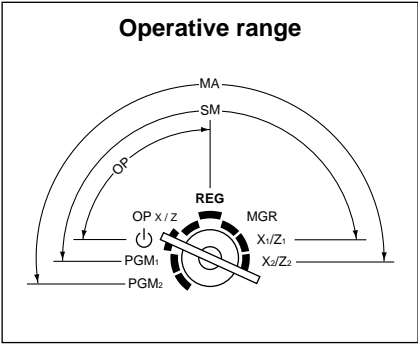

The mode switch has these settings:

- ⏻ :** This mode locks all register operations. No change occurs to register data.
- OP X/Z:** This setting allows cashiers/clerks to take X or Z reports for their sales information. (This setting may be used only when your register has been programmed for "OP X/Z mode available" in the PGM2 mode.) And it can be used to toggle receipt state "ON" and "OFF" by pressing the **RCPT** key.
- REG:** For entering sales
- PGM1:** To program those items that need to be changed often: e.g., unit prices of departments or PLUs, and percentages
- PGM2:** To program all PGM1 items and those items that do not require frequent changes: e.g., date, time, or a variety of register functions
- MGR:** For manager's and submanager's entries
The manager can use this mode to make entries that are not permitted to be made by cashiers - for example, after-transaction voiding and override entry.
- X1/Z1:** To take the X/Z report for various daily totals
- X2/Z2:** To take the X/Z report for various periodic (weekly or monthly) consolidation

2 Drawer lock key

This key locks and unlocks the drawer. To lock it, turn 90 degrees counterclockwise. To unlock it, turn 90 degrees clockwise.

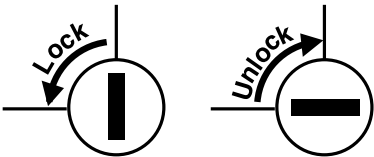
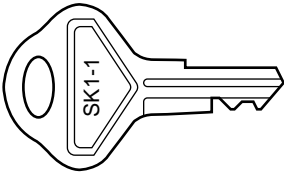

DISPLAYS

Operator display

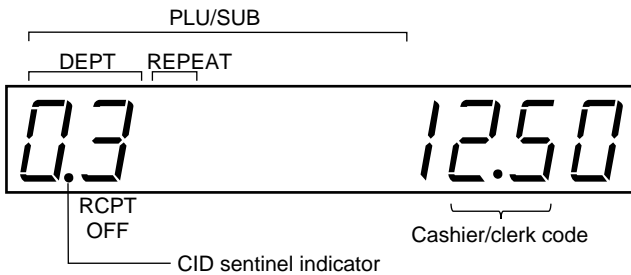

Customer display (Pop-up type)



- Amount:** Appears in the far-right eight (max.) positions.
- Cashier code:** Appears in the second and third positions (two digits).
- Clerk code:** Appears in the second and third positions (two digits) with "C" in the fifth position.
- Number of repeats for repetitive registrations:**
The number of repeats is displayed, starting at "2" and incremented with each repeat. When you have registered ten times, the display will show "0."
Example: (2 → 3 → 4 … 9 → 0 → 1 → 2 …)

Receipt function status:
The indicator "_" appears in the ninth position when the receipt function is put in the OFF status.

Time: Appears in the second to sixth positions (using 24-hour format) in the OP X/Z, REG, or MGR mode. In the REG, or MGR mode, press the key to display the time.

Machine state symbols

- \overline{P} : Appears in the tenth place during programming.
- \overline{E} : Appears in the tenth place when an error is detected.
- (Floating): Appears when a minus department or PLU/subdepartment entry is made or when a discount, refund, or void entry is made.
- \square : Appears in the tenth place when the subtotal is displayed or when the amount tendered is smaller than the sale amount.
- \mathcal{L} : Appears in the tenth place when the through key is pressed to calculate a subtotal in foreign currency.
- \mathcal{F} : Appears in the tenth place when a transaction is finalized by pressing the , , through , or through key.
- \mathcal{C} : Appears in the tenth place when the change due amount is displayed or when the cash/cheque declaration is compulsory.
- \cup : Appears in the tenth place when the key is pressed in the MGR mode, indicating the entry into the VOID mode. While your register is in the VOID mode, this symbol continues to be in the display except when department codes, PLU codes or subtotals are displayed. Also appears when a subtotal void is made.
- : Appears right below the tenth place when the cash in drawer amount exceeds a programmed sentinel amount. The sentinel check is performed for the total cash in drawer. Also appears right below the eighth place when the VAT shift is effective.

PRIOR TO PROGRAMMING

1 General instructions

This chapter illustrates how to program your cash register.
 All the programming items can be programmed by the **Job-Code-Based Programming** described later.
 However, your machine allows you to program some items using the **Direct Programming**, which does not require you to enter the job code.

Job-Code-Based Programming

Simplified procedure

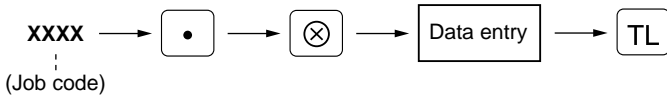

Direct Programming

Sample procedure

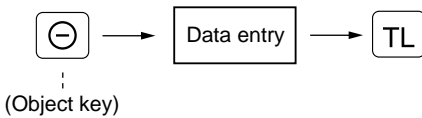

2 How to program alphanumeric characters

You can program alphanumeric characters for departments, PLUs, functions and so on in the character entry mode.

There are two ways for programming characters: using character keys on the keyboard and entering character codes with numeric keys on the keyboard.

Using character keys on the keyboard

Enter a character according to the position of the figure shown below.

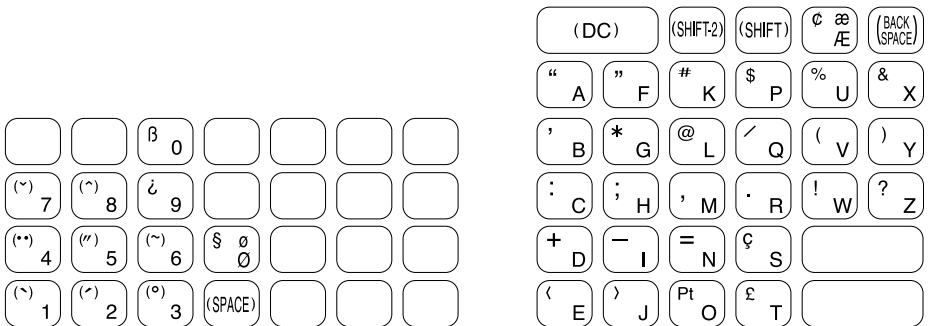

[Ex.]

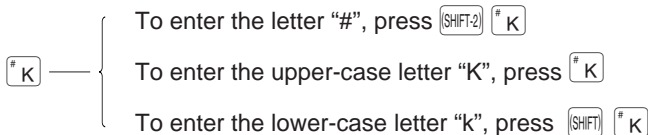

- Numerals, letters and symbols are programmable simply by pressing the corresponding keys.
- Characters may only be entered in single size or in double size. **By default, the single-size character mode is selected.** To enter a character in double size, press the (DC) key before you enter the corresponding character.

Example To program the word “SHARP” in double size, do the following key-in.

(DC) S (DC) H (DC) A (DC) R (DC) P

- Letters of alphabets “A” through “Z”, “Ø” and “Æ” are possible to be entered in lower case or in upper case. **By default, the upper-case letter mode is selected.** To enter a character in lower case, press the (SHIFT) key before you enter the character. To return to the upper-case letter mode, press the (SHIFT) key again.

Example To program the word “Sharp”, do the following key-in.

S (SHIFT) H A R P

- Symbols and special letters are programmable by using the (SHIFT-2) key. To enter a character, press the (SHIFT-2) key before you enter the corresponding character.

Example To program letters “# Å Ä” with the letter “#” being double size

(DC) (SHIFT-2) # (SHIFT-2) (°°) A (SHIFT-2) (°) A

Editing the characters

You can edit the characters you entered. Pressing a character key replaces the current character with a new one. To edit the characters, use the (BACK SPACE) key.

(BACK SPACE): Backs up the cursor, erasing the character to the left.

■ Entering character codes

- Numerals, letters and symbols are programmable by entering character codes and the (00) key. See the alphanumeric character code table on the next page. In this way, you can program characters other than the characters on the programming key sheet.

XXX → (00) XXX: Character code (3 digits)

- Double-size characters can be made by entering the character code 253.

Example To program the word “SHARP” with the letter “S” being double size

253 (00) 083 (00) 072 (00) 065 (00) 082 (00) 080 (00)
 S H A R P

Alphanumeric character code table

Code	Character	Code	Character	Code	Character	Code	Character	Code	Character
001	á	046	.	091	Ä	136	→	193	ı
002	â	047	/	092	Ö	137	ƒ	194	Ġ
003	ê	048	0	093	Ü	138	℘	195	Ş
004	î	049	1	094	^	139	◀	196	Ĝ
005	ì	050	2	095	_	140	▶	197	ġ
006	í	051	3	096	'	141	ƒ	198	Ƙ
007	ô	052	4	097	a	142	τ	199	ƙ
008	ó	053	5	098	b	143	↓	200	ƚ
009	û	054	6	099	c	144	ç	201	ƚ
010	ú	055	7	100	d	145	°	202	Ž
011	œ	056	8	101	e	146	ı	203	Đ
012	ú	057	9	102	f	147	Û	204	đ
013	ú	058	:	103	g	148	à	205	Ĉ
014	ř	059	;	104	h	149	Æ	206	ċ
015	ó	060	<	105	i	150	ø	207	€
016	Λ	061	=	106	j	151	Å	208	Ɔ
017	Ψ	062	>	107	k	152	ǻ	209	˘
018	Γ	063	?	108	l	153	é	210	ě
019	ˆ	064	@	109	m	154	è	211	š
020	Ω	065	A	110	n	155	Pt	212	č
021	Δ	066	B	111	o	156	i	213	ž
022	Θ	067	C	112	p	157	Ñ	214	ý
023	Ξ	068	D	113	q	158	ò	215	ù
024	Π	069	E	114	r	159	£	216	ň
025	Σ	070	F	115	s	160	¥	217	˘
026	Υ	071	G	116	t	161	◦	218	˘
027	Φ	072	H	117	u	162	Γ	219	ř
028	Ú	073	I	118	v	163	┘	224	*
029	Ú	074	J	119	w	164	˘	225	§
030	Ŏ	075	K	120	x	165	˘	226	∅
031	Ŏ	076	L	121	y	177	Á	227	ˆ
032	(space)	077	M	122	z	178	Í	228	↑
033	!	078	N	123	{	180	Ā	229]
034	"	079	O	124		181	ā	230	[
035	#	080	P	125	}	182	Ē	231	"
036	\$	081	Q	126	ß	183	ē	232	ä
037	%	082	R	127	¢	184	Ī	233	ö
038	&	083	S	128	!!	185	ī	234	û
039	'	084	T	129	₁	186	Ū	235	æ
040	(085	U	130	₂	187	ū	236	â
041)	086	V	131	₃	188	Ů	237	É
042	*	087	W	132	₄	189	Ũ	238	ñ
043	+	088	X	133	½	190	Č	253	*(DC)
044	,	089	Y	134	F/T	191	Š		
045	-	090	Z	135	←	192	Ç		

*(DC): Double-size character code

PROGRAMMING

Your machine allows you to program in two modes: PGM1 and PGM2. The PGM1 mode is for programming those items that need to be changed often: unit prices of departments/PLUs, and percentages. The PGM2 mode is used for programming all PGM1-mode programs and those items that require less frequent changes: date, time, tax rate, and the functions of each key. We describe below the programming or setting procedures of various items.

Program every item necessary for your store following the appropriate procedures.

* To set the mode switch to the PGM1 position, use the manager or submanager key; and to set to the PGM2 position, use the manager key.

■ Preparations for Programming

1. Plug your machine into a standard wall outlet.
2. Put the manager or submanager key in the mode switch and turn it to the PGM1 or PGM2 position depending upon the programming you are about to do.
3. Check to see whether both journal and receipt rolls are present in the machine. If they are missing, install journal and receipt paper rolls correctly referring to the procedure in "4. Installing and removing the paper roll" under "OPERATOR MAINTENANCE".
4. Program necessary items into your machine.

Direct Programming

1 Setting the date and time

■ Date PGM 2

Enter the day (one or two digits), month (two digits), and year (two digits) in this sequence.

Procedure

X X X X X X → #
Date (five or six digits)

Example 26 August, 1998

Key operation

260898 #

Print

26/08/98 1:37
000000 #0001

PGM2

26/08/98 —Date

■ Time PGM 2

Set the time using the 24-hour format. For example, when the time is set to 2:30 AM, enter 230; and when it is set to 2:30 PM, enter 1430. Once you set the time, the internal clock unit will continue to run as long as the built-in battery is alive and update the date (day, month, year) properly.

Procedure

X X X X → #
Time (max. four digits)

Example Setting the time as 2:30 PM (14:30)

Key operation

1430 #

Print

```

26/08/98 14:30
000000 #0002

*PGM2*

14:30
    
```

Time

2 Programming for departments

Your machine is equipped with 20 standard departments and up to 50 optional departments. Your machine allows you to perform the following programming for each department:

■ Unit price PGM 1 PGM 2

Procedure

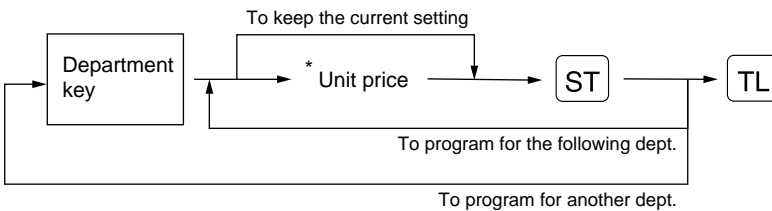

* Unit price: max. six digits (9999.99)

Example Programming the unit price 10.00 for department 1

- | | | |
|--|--|------------------|
| <p>1. Press the department 1 key.
• The current unit price will be displayed.</p> | 1 | 0 1 0 . 0 0 |
| <p>2. Enter the unit price "1000."</p> | 1000 | 0 1 1 0 0 0 |
| <p>3. Press the ST key to program this setting.</p> | ST | 0 2 0 . 0 0 |
| <p>4. Press the TL key to finalize the programming and generate a programming report.</p> | TL | 0 . 0 0 |

PGM2	
D01	10.00
DPT. 01	G01
0000003	COL17

Dept. code
Unit price

Functional selection PGM 2

Procedure

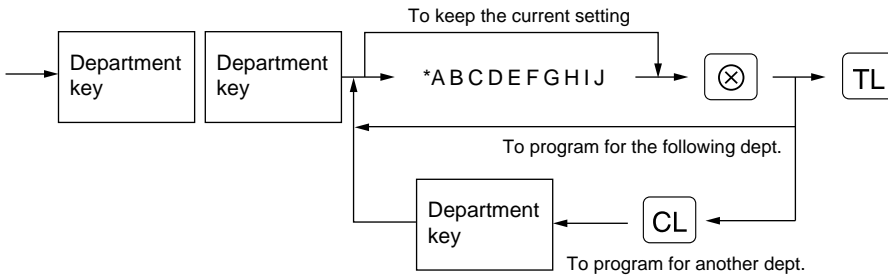

* Item:	Selection:	Entry:
A	Always enter 0.	0
B	VAT6 or TAX6	No
		Yes
C	VAT5 or TAX5	No
		Yes
D	VAT4 or TAX4	No
		Yes
E	VAT3 or TAX3	No
		Yes
F	VAT2 or TAX2	No
		Yes
G	VAT1 or TAX1	No
		Yes
H	Normal/SICS (Single Item Cash Sale)/	Normal
	SIF (Single Item Finalization)	SICS
		SIF
I	Significant digit for HALO	1 through 9
J	Number of zeros to follow the significant digit for HALO	0 through 7

Note

Tax status

- The tax system of your machine has been factory-set to automatic VAT1-6. If you desire to select any of automatic tax 1-6, manual VAT1-6, manual VAT1, manual tax 1-6, and the combination of the automatic VAT 1-3 and the automatic tax 4-6, consult your dealer.
- When the combination of the automatic VAT1-3 and automatic tax 4-6 system is selected, one of the VAT1(G), VAT2(F) and VAT3(E) can be selected in combination with tax 4-6.
Example: BCDEFG= 100100, 110100, 111010

Normal department/SICS (Single Item Cash Sale) / SIF (Single Item Finalization)

- If an entry of a department programmed for SICS is made first, the sale will be finalized as soon as the department key is pressed. If the entry is made after entering a department not programmed for SICS, the sale will not be finalized until the **[TL]** key is pressed.
- Whenever a sale is made to a department set for SIF, the sale is finalized as soon as the department key is pressed.

HALO (High Amount Lockout)

- You can set an upper limit amount (HALO) for each department. The limit is effective for the REG-mode operations and can be overridden in the MGR mode.
- IJ is the same as $I \times 10^J$.
For example, presetting 14 (100.00) here means that amount entries of up to 100.00 are allowed in the REG mode. When you preset 17, however, the upper limit amount is 99999.99.

Example

Programming for department 4 as follows: A=0, B=0, C=0, D=0, E=0, F=0, G=1, H=0, I=9 and J=5

1. Press the department 4 key twice.

[4] [4]

A B C D E F G H I J

:0:0 0 0 0 0 0 0 0 1 7

- The current parameter setting will be displayed.

2. Set the parameters as follows:

- You can change the value at the blinker.

Go to the desired position with the following keys:

[.].....Moves the blinker to the right.

:0:0 0 0 0 0 0 0 1 7



0:0:0 0 0 0 0 0 1 7

[00].....Moves the blinker to the left.

0:0:0 0 0 0 0 0 1 7



:0:0 0 0 0 0 0 0 1 7

- Enter the figure.

0000001095

0 0 0 0 0 0 1 0 9:5:

3. Press the **[⊗]** key to program this setting.

[⊗]

:0:0 0 0 0 0 0 0 1 7

4. Press the **[TL]** key to finalize the programming and generate a programming report.

[TL]

0 . 0 0

Print

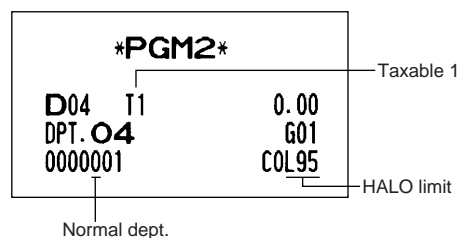

3 Price lookup (PLU) programming

A PLU code can be up to six digits (free code).

Unit price PGM 1 PGM 2

Procedure

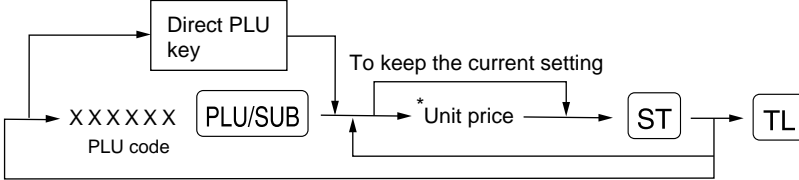

*Unit price: max. six digits (9999.99)

Example Programming the unit price 1.25 for PLU code 1

- | | | |
|---|------------------|---------------------|
| 1. Enter the PLU code "1" and press the PLU/SUB key. | 1 PLU/SUB | 0 0 0 0 0 1 0 . 0 0 |
| 2. Enter the unit price "125." | 125 | 0 0 0 0 0 1 1 2 5 |
| 3. Press the ST key to program this setting. | ST | 0 0 0 0 0 2 0 . 0 0 |
| 4. Press the TL key to finalize the programming and generate a programming report. | TL | 0 . 0 0 |

Print

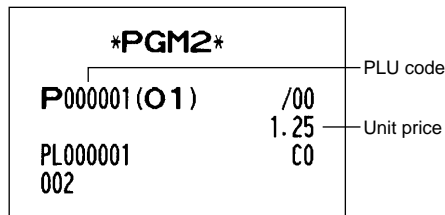

Functional selection PGM 2

Procedure

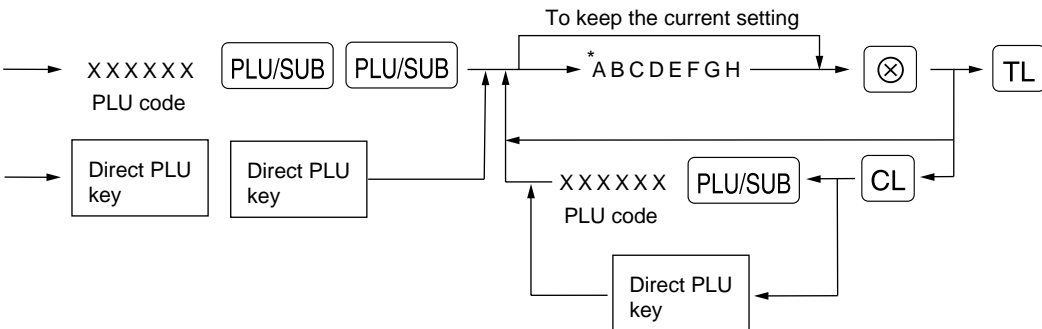

* Item:		Selection:	Entry:
A	Sign (plus/minus)	Plus	0
		Minus	1
B	VAT6 or TAX6	No	0
		Yes	1
C	VAT5 or TAX5	No	0
		Yes	1
D	VAT4 or TAX4	No	0
		Yes	1
E	VAT3 or TAX3	No	0
		Yes	1
F	VAT2 or TAX2	No	0
		Yes	1
G	VAT1 or TAX1	No	0
		Yes	1
H	Mode	Prohibit mode	0
		Subdepartment mode	1
		PLU mode	2
		PLU/subdepartment mode	3
		Delete mode	4

Note

Sign (plus/minus)

The function of every PLU/subdepartment varies according to the combination of its sign and the sign of its associated department as follows:

Sign		Function of PLU/subdepartment
Department	PLU/ subdepartment	
+	+	Serves as a normal plus PLU/subdepartment
-	-	Serves as a normal minus PLU/subdepartment
+	-	Accepts store coupon entries, but not split-pricing entries
-	+	Not valid; not accepted

Tax status

- The tax system of your machine has been factory-set to automatic VAT1-6. If you desire to select any of automatic tax 1-6, manual VAT1-6, manual VAT1, manual tax 1-6, and the combination of the automatic VAT 1-3 and the automatic tax 4-6, consult your dealer.
- When the combination of the automatic VAT1-3 and automatic tax 4-6 system is selected, one of the VAT1(G), VAT2(F) and VAT3(E) can be selected in combination with tax 4-6.
Example: BCDEFG= 100100, 110100, 111010
- A PLU not programmed for any of these tax statuses is registered depending on the tax status of the department which the PLU belongs to.

Mode parameter

- **PLU mode:** Allows a PLU entry to be made by entering an assigned PLU code and depressing the **[PLU/SUB]** key.
- **Subdepartment mode:** Allows a subdepartment entry to be made by entering a unit price, pressing the **[AMT]** key, assigned PLU code and then pressing the **[PLU/SUB]** key.
- **PLU/subdepartment mode:** Allows PLU entries to be made in both the PLU and subdepartment modes.
- **Delete mode:** Deletes program data for each PLU.
- **Prohibit mode:** Prohibits the entry of any assigned PLU code. This mode does not clear the PLU/subdepartment program data.

Example

Programming for PLU code 1 as follows: A=0, B=0, C=0, D=0, E=0, F=0, G=1, and H=2

- Enter the PLU code "1" and press the **PLU/SUB** key twice.

	A	B	C	D	E	F	G	H
P	0	0	0	0	0	0	0	2
- Set the parameters A to H.
 - You can go to the desired position with the **00** or **.** key.

P	0	0	0	0	0	0	1	2
---	---	---	---	---	---	---	---	---
- Press the **⊗** key to program this setting.

P	0	0	0	0	0	0	0	2
---	---	---	---	---	---	---	---	---
- Press the **TL** key to finalize the programming and generate a programming report.

								0 . 0 0
--	--	--	--	--	--	--	--	---------

Print

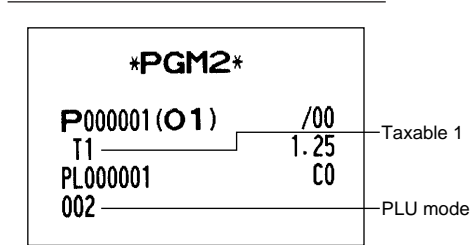

PLU assignment to departments

PGM 1

PGM 2

Procedure

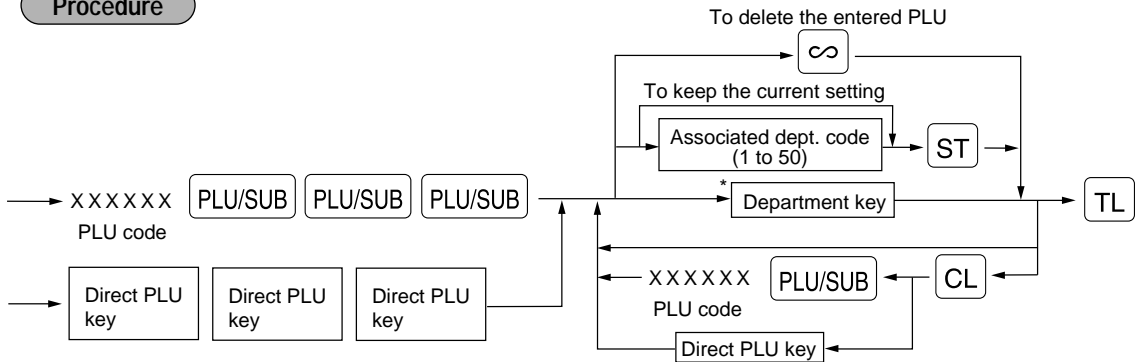

*Department key to be associated with the entered PLU

Note

- The following functions of the PLU depend on the programming for its associated department:
 - Grouping (Group 1 through 14)
 - SICS (Single Item Cash Sale)/SIF (Single Item Finalization)/Normal
 - HALO (high amount lockout)

Example

Assigning PLU codes 1 and 2 to department 2

- Enter the PLU code "1" and press the **PLU/SUB** key three times.

0	0	0	0	0	1	0	1
---	---	---	---	---	---	---	---
- Press the the department 2 key to assign PLU code 1 to department 2.

0	0	0	0	0	2	0	1
---	---	---	---	---	---	---	---

3. Press the department 2 key to assign PLU code 2 to department 2.

2

0 0 0 0 0 3 0 1

4. Press the **TL** key to finalize the programming and generate a programming report.

TL

0 . 0 0

Print

```

*PGM2*
P000001 (O2) /00
T1 1.25
PL000001 C0
002
P000002 (O2) /00
0.00
PL000002 C0
002
  
```

Associated dept.

4 Programming for discount keys

■ Deduction amount (⊖) PGM 1 PGM 2

Procedure

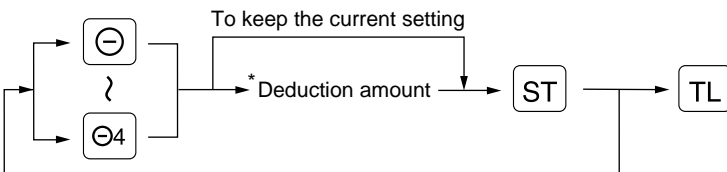

*Deduction amount: 0 - 999999

Example Assigning "10.00" to the ⊖ key

1. Press the ⊖ key.
2. Enter the deduction amount "1000."
3. Press the **ST** key to program this setting.
4. Press the **TL** key to finalize the programming and generate a programming report.

⊖

0 0 1 0 . 0 0

1000

0 0 1 1 0 0 0

ST

0 0 1 1 0 . 0 0

TL

0 . 0 0

Print

```

*PGM2*
F001 (←) 1
S -10.00
L17
  
```

Deduction amount

High amount lockout (HALO) and +/- sign (⊖) PGM 2

Procedure

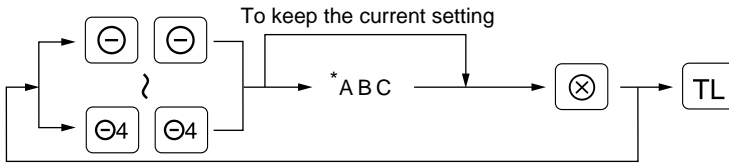

* Item:	Selection:	Entry:
A Sign (plus/minus)	Plus	0
	Minus	1
B Significant digit for HALO		1 through 9
C Number of zeros to follow the significant digit for HALO		0 through 7

Note HALO (High Amount Lockout)

BC is the same as $B \times 10^C$.

For example, presetting 14 (100.00) here means that amount entries of up to 100.00 are allowed in the REG mode. When you preset 17, however, the upper limit amount is 99999.99.

Example Programming for the ⊖ key as follows: A=1, B=1, and C=3

- | | | A B C |
|---|-----|------------------|
| 1. Press the ⊖ key twice. | ⊖ ⊖ | 0 0 1 1 1 7 |
| 2. Set the parameters A to C.
• You can go to the desired position with the 00 or . key. | 113 | 0 0 1 1 1 3 |
| 3. Press the ⊗ key to program this setting. | ⊗ | 0 0 1 1 1 3 |
| 4. Press the TL key to finalize the programming and generate a programming report. | TL | 0 . 0 0 |

Print

PGM2

F001 (→) 1

S -10.00

L13 — HALO limit

5 Programming for percent keys

■ Percent rate (%) PGM 1 PGM 2

Procedure

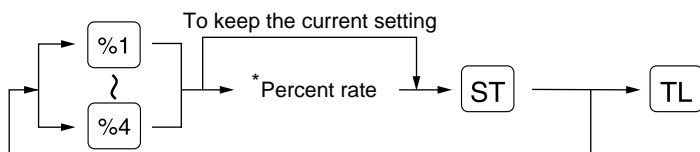

* Percent rate: 0.00 - 100.00

Note You must use a decimal point when setting percentage rates that are fractional.

Example Assigning 10.25% to the %1 key

Key operation

%1 10 . 25 ST
TL

Print

```

*PGM2*
F005 %1
S          -10.25% — Percent rate
L100.00%
    
```

■ Sign (+/-) (%) PGM 2

Procedure

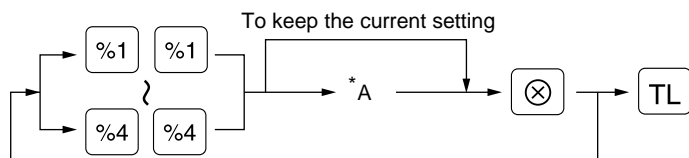

* Item:	Selection:	Entry:
A Sign (plus/minus)	Plus (premium)	0
	Minus (discount)	1

Example Programming minus sign for the %1 key

Key operation

%1 %1 1 ⊗
TL

Print

```

*PGM2*
F005 %1
S          -10.25% — Discount
L100.00%
    
```

6 Programming for exchange keys

■ Currency exchange rate (EX) PGM 1 PGM 2

Procedure

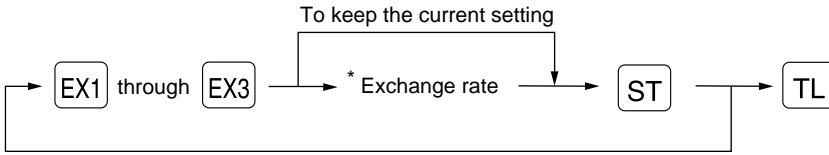

* Currency exchange rate: 0.000000 - 999.999999

Note You must use a decimal point when setting conversion rates that are fractional.

Example Assigning 0.6068 to the EX1 key

Key operation

EX1 0 . 6068 ST
TL

Print

```

*PGM2*
F052 EXCH1      0.606800 Exchange rate
  
```

7 Programming for the CA2 , RA , PO , CH and CR keys

■ High amount lockout (HALO) (CA2 , RA , PO , CH and CR) PGM 2

Procedure

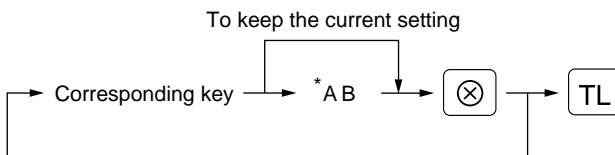

* AB is the same as $A \times 10^B$

A: Significant digit (1 through 9)

B: Number of zeros to follow the significant digit (0 through 8)

Example Programming a HALO limit of 1000.00 (15) for the CR2 key

Key operation

CR2 15 X
TL

Print

```

*PGM2*
F049 CREDIT2    L15 HALO limit
                0000000
  
```

8 Programming the tax rate

Tax rate PGM 2

Procedure

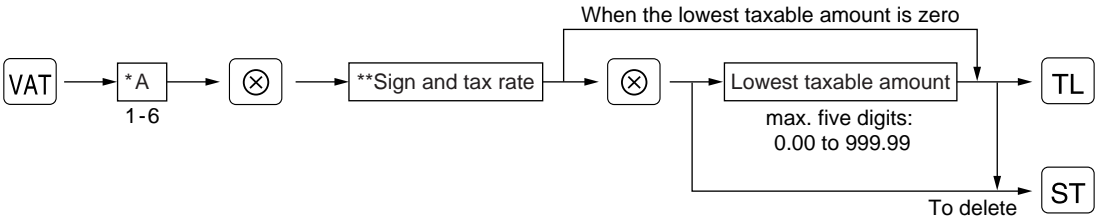

* A: Enter a corresponding tax rate number. For example, when you program a tax rate as tax rate 1, enter “1”, and when you program it as tax rate 6, enter “6”.

** Sign and tax rate: XYYY.YYYY
 Tax rate= 0.0001 to 100.0000
 Sign +/- = 1/0

- Note**
- The lowest taxable amount is valid only when you select add on tax system. If you select VAT (Value added tax) system, it is ignored.
 - If you make an incorrect entry before pressing the second (⊗) key in programming a tax rate, cancel it with the (CL) key; and if you make an error after pressing the second (⊗) key, cancel it with the (ST) key. Then program again from the beginning.
 - If you select VAT system, the sign which you program is ignored.

Example Programming the tax rate (+4%) as tax rate 2 with lowest taxable income as 0.12

1. Press the (VAT) key.	VAT	P	0 . 0 0
2. Enter the tax rate “2”.	2 (⊗)	2	0 . 0 0
3. Enter the tax rate “+4%.”	4 (⊗)	2	0 . 0 0
4. Enter the lowest taxable amount “12.”	12	2	1 2
5. Press the (TL) key to finalize the programming and generate a programming report.	TL		0 . 0 0

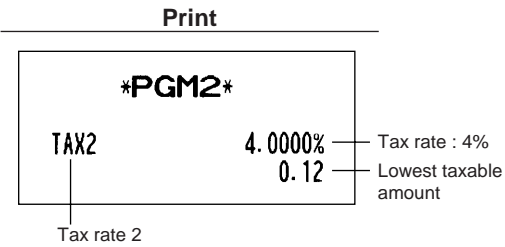

Job-Code-Based Programming

This section illustrates how to program items using job codes. Using job codes allows you to program a wide variety of items in comparison with direct programming.

Start this programming by entering a corresponding job code as shown below.

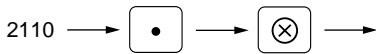

All the items which can be programmed by the job-code-based programming are listed on this page and the following, and those which can also be programmed by the direct programming are marked with the symbol “**Direct**” that follows job codes.

Note

When setting the parameters for a job code, the digit that is blinking is the one that can be changed. To go to the position of the parameter that you want to change, press either of the following keys :

- [•] Moves the blinker to the right.
- [00] Moves the blinker to the left.

1 Setting the date and time

Setting the date

PGM 2

2610

Direct

Enter day (one or two digits), month (two digits), and year (two digits) in this sequence.

Procedure

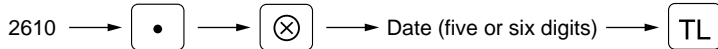

Example

Key operation

2610 [•] [⊗]
260898 [TL]

Print

```
26/08/98 14:50  
000000 #0001  
  
#2610 *PGM2*  
  
26/08/98
```

Date

Setting the time

PGM 2

2611

Direct

Set the time using the 24-hour format. For example, when the time is set to 2:30 AM, enter 230; and when it is set to 2:30 PM, enter 1430.

Procedure

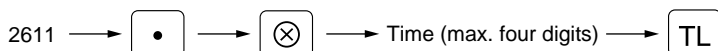

Example

Key operation

2611 [.] [⊗]
1430 [TL]

Print

```
26/08/98 14:30  
000000 #0002  
#2611 *PGM2*  
14:30
```

Time

2 Setting the register and consecutive numbers

Setting the register number PGM 2 2612

When your store has two or more registers, it is practical to set separate register numbers for their identification. You may set them in a maximum of six digits.

Procedure

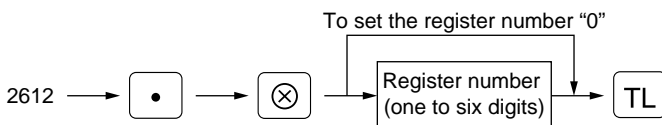

Example

Key operation

2612 [.] [⊗]
123456 [TL]

Print

```
26/08/98 14:31  
123456 #0003  
#2612 *PGM2*  
123456
```

Register number

Setting the consecutive number PGM 2 2613

The consecutive number is increased by one each time a receipt is issued. Enter a number (one to four digits) that is one less than the desired starting number.

Procedure

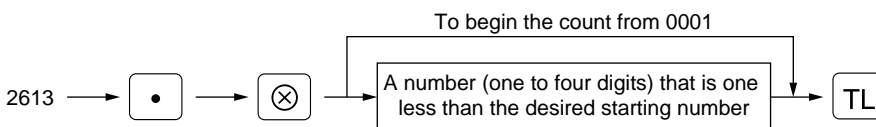

Example

Key operation

2613 [.] [⊗]
1000 [TL]

Print

```
26/08/98 14:31
123456 #1000
#2613 *PGM2*
1000
```

Consecutive number

3 Programming the tax rate

The tax rate

PGM 2

2711

Direct

Procedure

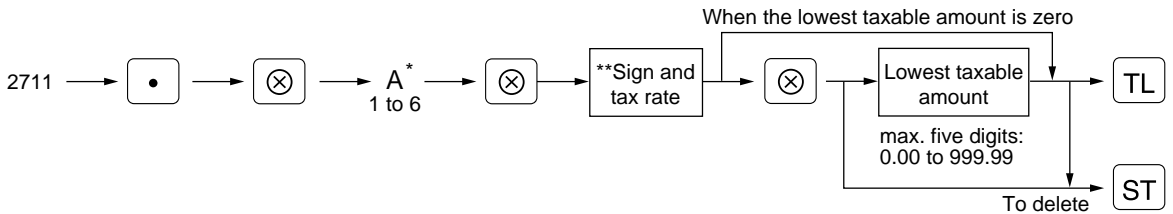

*A: Enter a corresponding tax rate number. For example, when you program a tax rate as tax rate 1, enter 1 and when you program it as tax rate 6, enter 6.

** Sign and tax rate: XXXX.YYYY

└ Tax rate= 0.0001 to 100.0000
└ Sign +/- = 1/0

Example

Key operation

2711 [.] [⊗]
2 [⊗]
4 [⊗]
12 [TL]

Print

```
#2711 *PGM2*
TAX2 4.0000%
0.12
```

Tax rate : 4%
Lowest taxable amount
Tax rate 2

Note

- The lowest taxable amount is valid only when you select add on tax system. If you select VAT (Value added system), it is ignored.
- If you make an incorrect entry before pressing the third [⊗] key in programming a tax rate, cancel it with the [CL] key; and if you make an error after pressing the third [⊗] key, cancel it with the [ST] key. Then program again from the beginning correctly.
- If you select VAT system, the sign which you program is ignored.

4 Programming for departments

Your machine is equipped with 20 standard departments and up to 50 optional departments.
Your machine allows you to perform the following programming for each department:

■ Functional programming PGM 2 2110

You can set each department for:

SICS (Single Item Cash Sale) / SIF (Single Item Finalization)

- SICS
If the first registration is to a department set for SICS, the sale is finalized as soon as the department key is pressed. If the sale is preceded by registrations to departments not set for SICS, a sale to a department set for SICS does not finalize and can be repeated until the TL key is pressed.
- SIF
Whenever a sale is made to a department set for SIF, the sale is finalized as soon as the department key is pressed.

Type of unit price entry

You may select one of the following four types of unit price entry for each department.

- Open and preset
- Preset only
- Open only
- Inhibit department key

Procedure

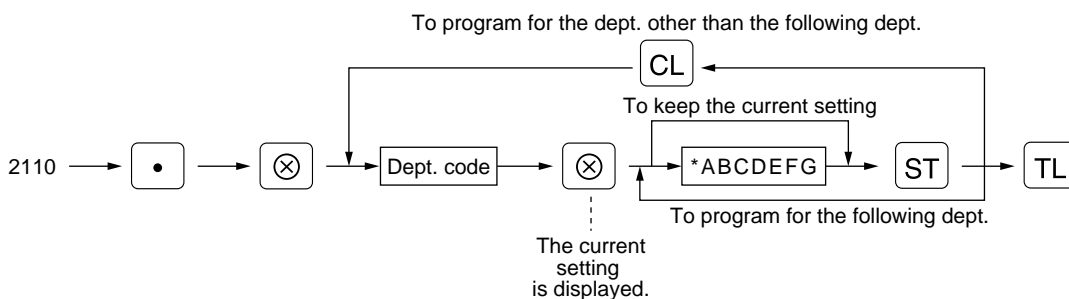

* Item:	Selection:	Entry:
A to D Always enter 0.		0
E SIF/SICS /Normal	SIF	2
	SICS	1
	Normal	0
F Always enter 0.		0
G Type of unit price entry	Open and preset	3
	Preset only	2
	Open only	1
	Inhibit department key	0

Example

Key operation

2110 [.] [⊗]
 3 [⊗] 0000003 [ST]
 [TL]

Print

```
#2110 *PGM2*
D03          0.00
DPT. 03      G01
0000003     COL17
```

A through G

Tax status PGM 2 2111 Direct

Assign a tax status to each department. When entries are made into taxable departments in a transaction, tax is automatically computed according to the associated tax rate as soon as the transaction is completed.

Procedure

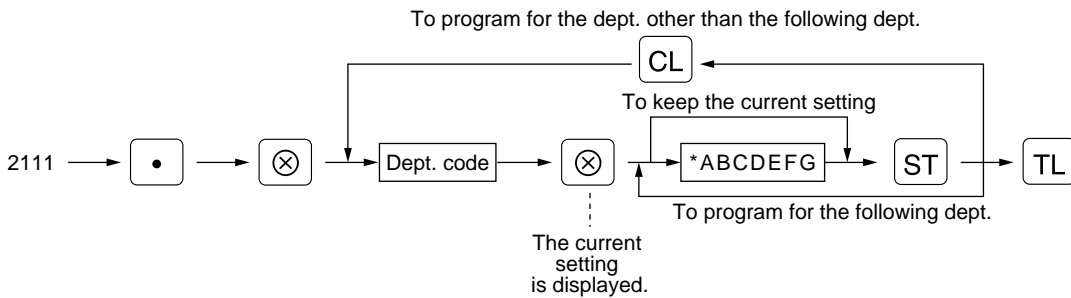

* Item:	Selection:	Entry:
A Always enter 0.		0
B VAT6 or TAX6	Yes	1
	No	0
C VAT5 or TAX5	Yes	1
	No	0
D VAT4 or TAX4	Yes	1
	No	0
E VAT3 or TAX3	Yes	1
	No	0
F VAT2 or TAX2	Yes	1
	No	0
G VAT1 or TAX1	Yes	1
	No	0

Note

- The tax system of your machine has been factory-set to automatic VAT1-6. If you desire to select any of automatic tax 1-6, manual VAT1-6, manual VAT1, manual tax 1-6, and the combination of the automatic VAT 1-3 and the automatic tax 4-6, consult your dealer.
- When the combination of the automatic VAT1-3 and automatic tax 4-6 system is selected, one of the VAT1(G), VAT2(F) and VAT3(E) can be selected in combination with tax 4-6.
 Example: BCDEFG= 100100, 110100, 111010

Example

Key operation	Print
2111 <input type="text" value="."/> <input type="text" value="⊗"/> 4 <input type="text" value="⊗"/> 0000110 <input type="text" value="ST"/> <input type="text" value="CL"/> 2 <input type="text" value="⊗"/> 0000101 <input type="text" value="ST"/> <input type="text" value="TL"/>	<pre> #2111 *PGM2* D04 T 23 0.00 DPT.04 G01 0000001 COL17 D02 T1 3 0.00 DPT.02 G01 0000001 COL17 </pre>

Tax status

A limit amount (HALO) of entry PGM 2 2112 Direct

You can set upper limit amounts (HALO: High Amount Lockout) for each department. The limit is effective for the REG-mode operations and can be overridden in the MGR mode. HALO limit is represented by two figures as follows:

Procedure

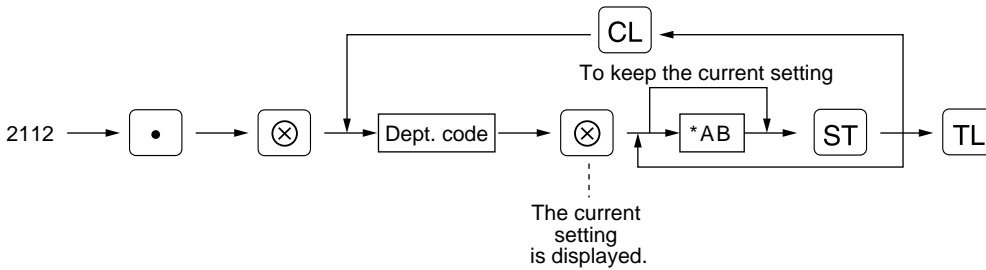

* AB is the same as $A \times 10^B$.

A: Significant digit (1 through 9)

B: Number of zeros to follow significant digit (0 through 7)

For example, presetting 14 (100.00) here means that amount entries of up to 100.00 are allowed in the REG mode. But when you preset 17, the upper limit amount is 99999.99.

Example

Key operation	Print
2112 <input type="text" value="."/> <input type="text" value="⊗"/> 1 <input type="text" value="⊗"/> 95 <input type="text" value="ST"/> <input type="text" value="TL"/>	<pre> #2112 *PGM2* D01 0.00 DPT.01 G01 0000001 COL95 </pre>

HALO limit

■ Alphanumeric characters PGM 2 2114

You can program a maximum of 16 characters (item label) for each department. (However, the default setting is for a 12-character label.)

Select the characters you want to program, referring to section “2 How to program alphanumeric characters” in chapter “PRIOR TO PROGRAMMING”.

Procedure

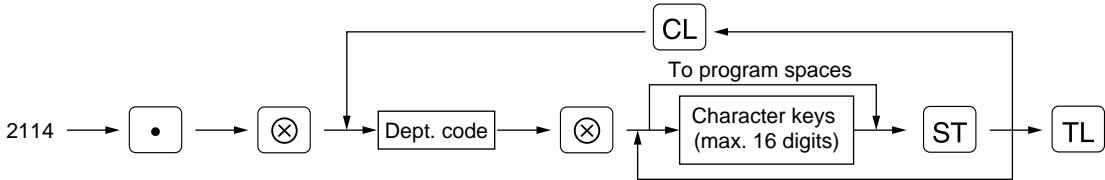

Example

Key operation

2114 . ⊗
 1 ⊗
 STEAK ST
TL

Print

```
#2114 *PGM2*
D01          0.00
STEAK      G01
0000001    COL95
```

Label programmed for dept. 1

■ Unit price PGM 1 PGM 2 1110 Direct

You can program unit prices up to a maximum of six digits (9999.99). Even if a department is not programmed to allow the entry of preset unit prices in functional programming (job 2110), the department is automatically changed to allow the entry of preset unit prices by this programming entry.

Procedure

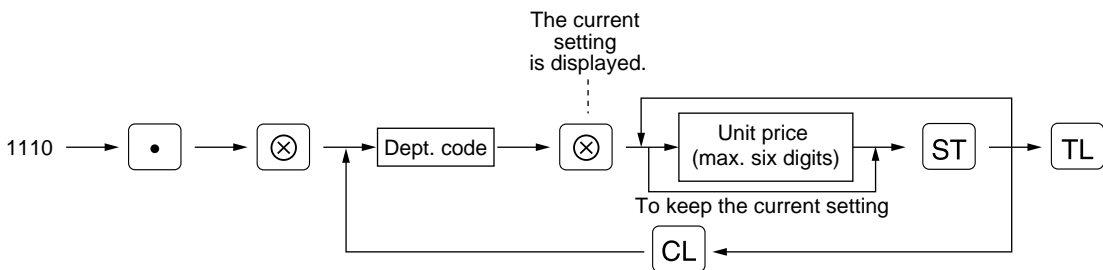

Example

Key operation

1110 . ⊗
 1 ⊗ 1000 ST
TL

Print

```
#1110 *PGM2*
D01          10.00
STEAK      G01
0000003    COL95
```

Unit price

■ Commission group assignment PGM 2 2115

Your machine allows you to assign a commission group (1-9) to each department.

Procedure

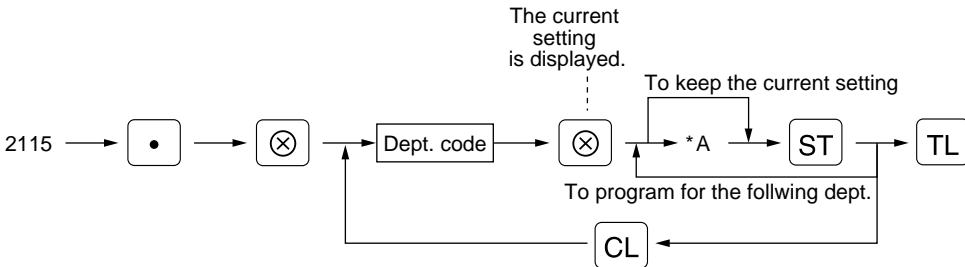

* A: Commission group 0-9 (0 = no commission)

Example

Key operation

```

2115 • ⊗
      1 ⊗ 1 ST
      CL 5 ⊗ 2 ST
           TL
    
```

Print

```

#2115 *PGM2*

D01          10.00
STEAK       G01
0000003     C1L95
D05          0.00
DPT. 05     G01
0000001     C2L17
    
```

Commission group number

■ Group number PGM 2 2116

You can assign departments to a maximum of 14 groups (1 through 14).

This programming enables you to take group department sales reports.

Procedure

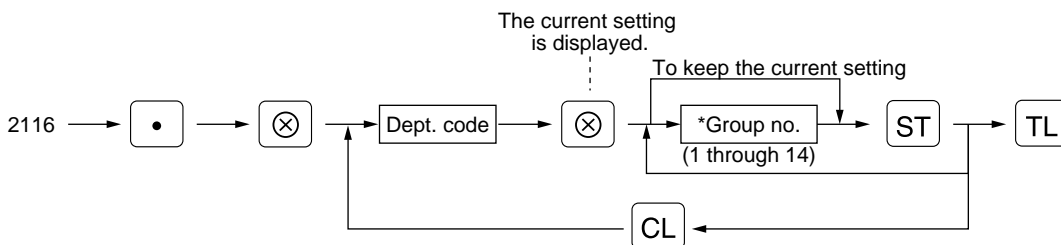

* Group number: Dept. (+) 1 through 9 (groups 1 through 9)
 Dept. (-) 10
 Hash (+) dept. 11
 Hash (-) dept. 12
 Bottle return (+) dept. 13
 Bottle return (-) dept. 14

Note

The standard model provides no hash dept./bottle return dept. If you need them, please consult your dealer.

Example

Key operation

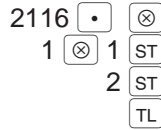

Print

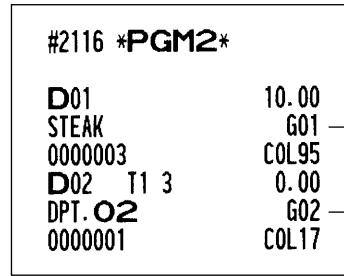

Department key positioning PGM 2 2119

You can assign a department number to each key position. Each key position has a corresponding key number. Departments may be freely selected for the number of department keys and their positions. To assign the department to a key position, select the key number of the position. For key number position, refer to section "2 Standard key number layout" in chapter "KEYBOARD".

Procedure

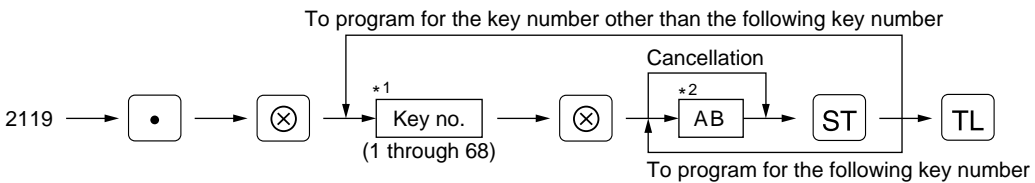

*1 The key number placement is determined by your local Authorized SHARP Dealer.

*2 AB is a department code.

Example

Key operation

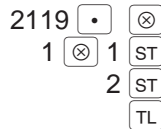

Print

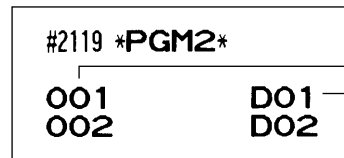

5 Price lookup (PLU) programming

Your machine has two kinds of PLU registration methods.

Direct PLU registration: Accomplished by depressing item key (direct PLU key) directly.

Indirect PLU registration: Accomplished by making an entry of PLU code and pressing the PLU/SUB key.

Each PLU requires you to program the following:

PLU code (six digits)

Associated department

When a PLU is associated with a department, the following functions of the PLU depend on the programming for the corresponding department.

- Grouping (Group 1 through 14)
- HALO (only for the subdepartment)
- Single item cash sale/Single item finalization

Unit price (max. six digits)

You will usually have unit prices programmed for individual PLUs as PLU preset unit prices. If you program unit price "0" for a PLU, you can enter only the selling quantity of the PLU, i.e. the PLU can be used only as a counter.

Base quantity for split-pricing entries - two digits

Program a base quantity for each PLU/subdepartment dedicated to split-pricing entries.

PLU, subdepartment, PLU/subdepartment, delete, or prohibit mode

- If the PLU mode (i.e. automatic preset unit price entry) is selected, individual PLU entries can be made by entering the assigned code and depressing the PLU/SUB key (or by depressing a direct PLU key without any PLU code entry).
- If the subdepartment mode is selected, the AMT key must be depressed after the price entry followed by the PLU code entry. The entry is finalized by the PLU/SUB key depressed.
- If the PLU/subdepartment mode is selected, the entries in both the PLU and subdepartment modes are available.
- If the delete mode is selected, the corresponding program data for each PLU is deleted.
- If the prohibit mode is selected, the assigned PLU code cannot be entered. This mode does not clear the PLU/subdepartment program data.

Sign (+/-)

The function of every PLU/subdepartment varies according to the combination of its sign and its associate department's sign as follows:

Sign		Function of PLU/subdepartment
Dept.	PLU/subdept.	
+	+	Serves as a normal plus PLU/subdept.
-	-	Serves as a normal minus PLU/subdept.
+	-	Accepts store coupon entries, but not split-pricing entries.
-	+	Not valid; not accepted.

Tax status

Item label (12 characters) (option: max. 16 characters)

Commission group (1 to 9)

Link PLU

Any PLU is able to link to any other PLU (e.g. bottle deposit). However, the number of links is a maximum of 5. Even if more than 5 PLUs are linked, the sixth or higher link is not actualized.

Direct PLU key positioning

Note

For some items, you can program in two ways: programming an individual PLU code and for a range of sequential PLU codes. The procedure marked "For each PLU" shows individual PLU programming. "For a range of PLUs" shows sequential range PLU programming.

Department assignment

PGM 1 PGM 2 1200 2230 Direct

Procedure

For each PLU

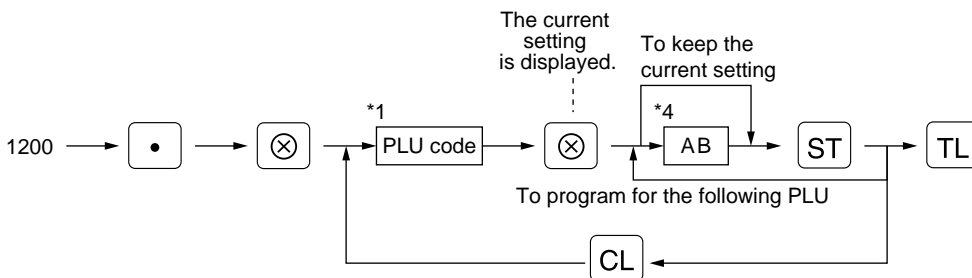

Note

As soon as the programming is completed for one PLU, the next PLU code appears in the display.

For a range of PLUs

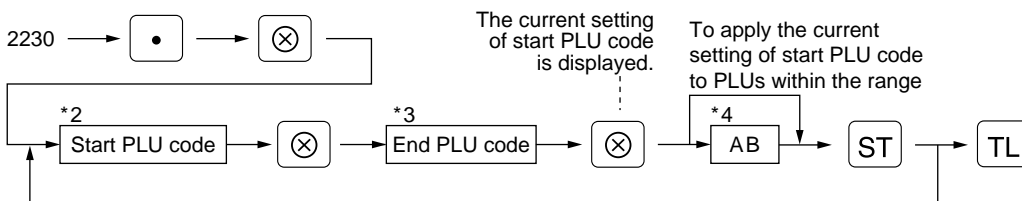

*1, 2, 3: 1 to 999999 (free code)

*4: AB: Associated department code

Example

For each PLU

Key operation

```
1200 . ⊗
      1 ⊗ 2 ST
           2 ST
           TL
```

Print

```
#1200 *PGM2*
P000001 (02) /00
              0.00
PL000001     C0
002
P000002 (02) /00
              0.00
PL000002     C0
002
```

PLU code
Associated dept.

For a range of PLUs

Key operation

```
2230 . ⊗
      11 ⊗ 20 ⊗
           3 ST
           TL
```

Print

```
#2230 *PGM2*
P000011     -P000020
              (03)
```

PLU range
Associated dept.

Unit prices PGM 1 PGM 2 1210 Direct

Procedure

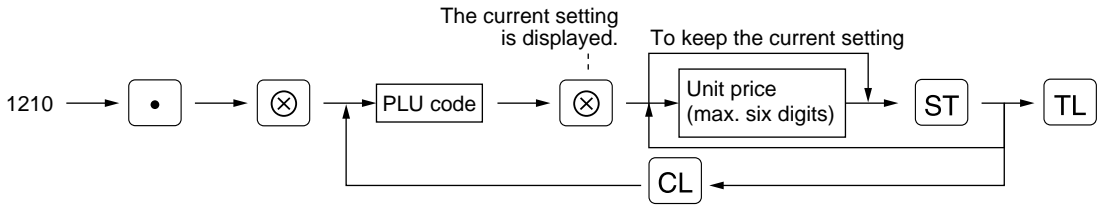

Example

Key operation

```

1210 . ⊗
1 ⊗ 125 ST
      TL
    
```

Print

```

#1210 *PGM2*

P000001(O2)      /00
                  1.25 — Unit price
PL000001
002              C0
    
```

Base quantity PGM 1 PGM 2 1211

Procedure

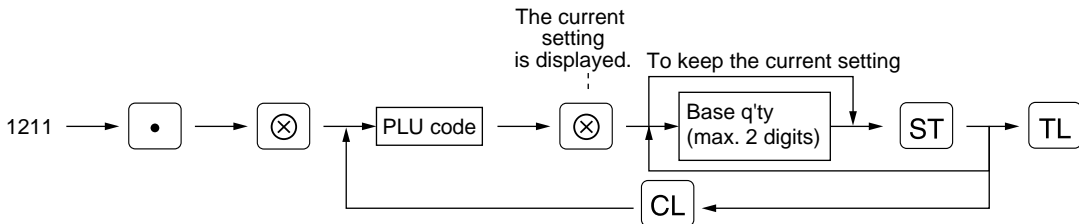

Example

Key operation

```

1211 . ⊗
2 ⊗ 12 ST
      TL
    
```

Print

```

#1211 *PGM2*

P000002(O2)      /12 — Base q'ty
                  0.00
PL000002
002              C0
    
```

Procedure

For each PLU

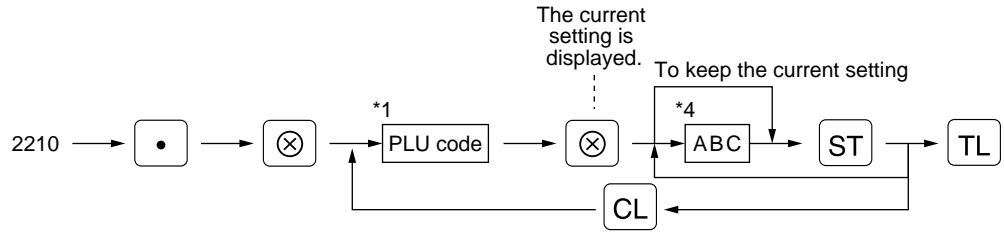

For a range of PLUs

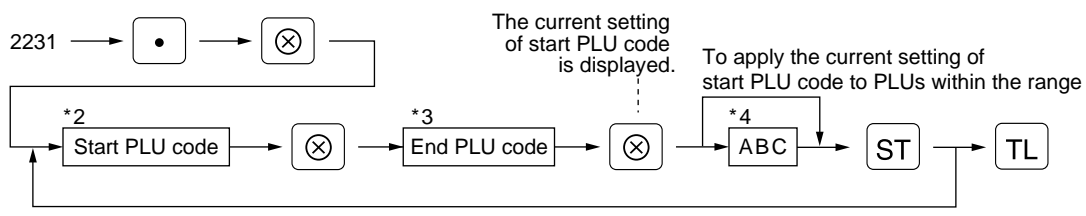

*1,2,3: 1 through 999999

*4: Item:	Selection:	Entry:
A and B Always enter 0.		0
C Mode parameter	Prohibit mode	0
	Subdept. mode	1
	PLU mode	2
	PLU/subdept. mode	3
	Delete mode	4

Example

For each PLU

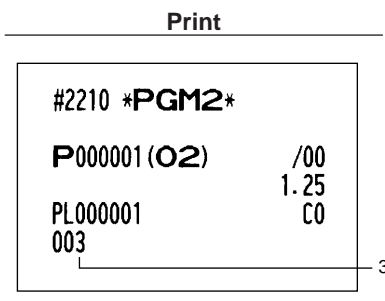
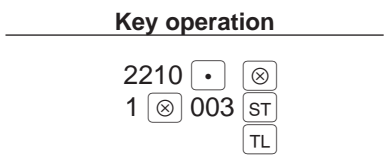

For a range of PLUs

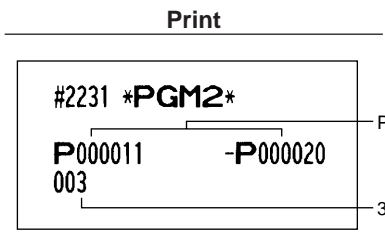
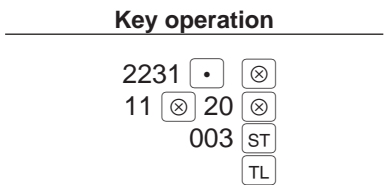

■ Sign (+/-) and tax status

PGM 2

2211

2232

Direct

Procedure

For each PLU

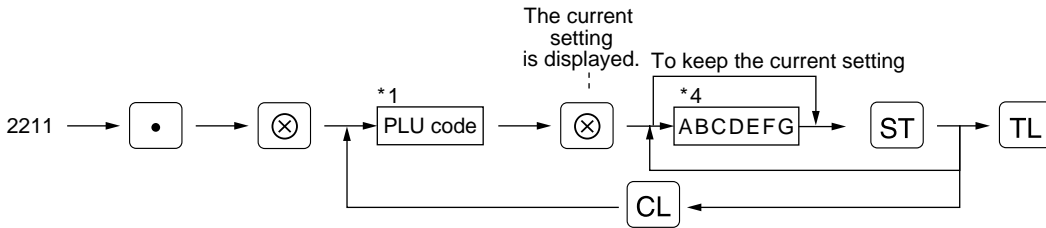

For a range of PLUs

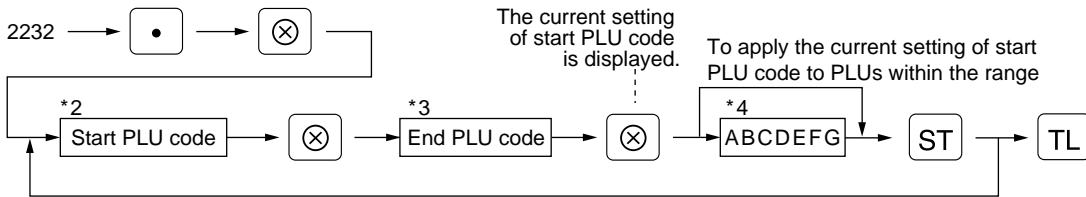

*1,2,3: 1 through 999999

*4: Item:	Selection:	Entry:
A Sign (+/-)	Minus PLU	1
	Plus PLU	0
B VAT6 or TAX6	Yes	1
	No	0
C VAT5 or TAX5	Yes	1
	No	0
D VAT4 or TAX4	Yes	1
	No	0
E VAT3 or TAX3	Yes	1
	No	0
F VAT2 or TAX2	Yes	1
	No	0
G VAT1 or TAX1	Yes	1
	No	0

Note

- The tax system of your machine has been factory-set to automatic VAT1–6. If you desire to select any of automatic tax 1–6, manual VAT1–6, manual VAT1, manual tax 1–6, and the combination of the automatic VAT 1–3 and the automatic tax 4–6, consult your dealer.
- When the combination of the automatic VAT1–3 and automatic tax 4–6 system is selected, one of the VAT1(G), VAT2(F) and VAT3(E) can be selected in combination with tax 4–6.
Example: BCDEFG= 100100, 110100, 111010
- A PLU not programmed for any of these tax statuses is registered depending on the tax status of the department which the PLU belongs to.

Example

For each PLU

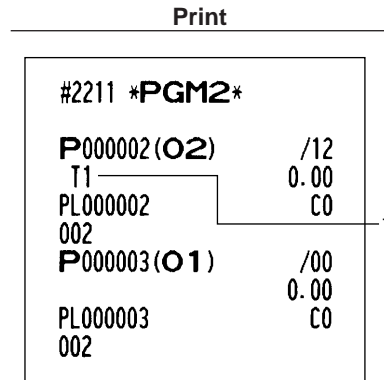
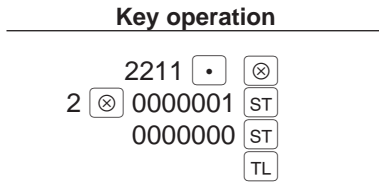

For a range of PLUs

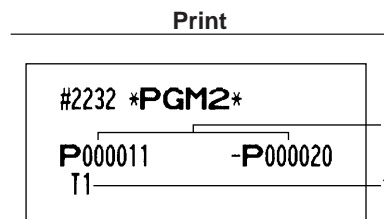
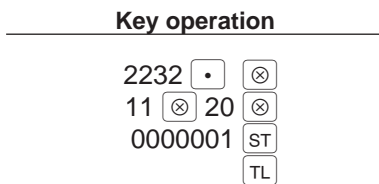

Alphanumeric characters PGM 2 2214

You can program a maximum of 16 characters (item label) for each PLU or subdepartment. (However, the default setting is for a 12-character label.) Select the characters you want to program, referring to section “2 How to program alphanumeric characters” in chapter “PRIOR TO PROGRAMMING”.

Procedure

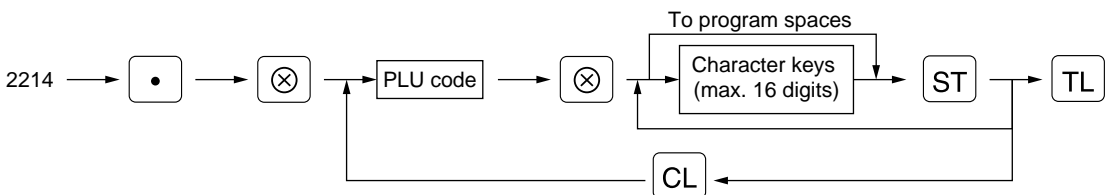

Example

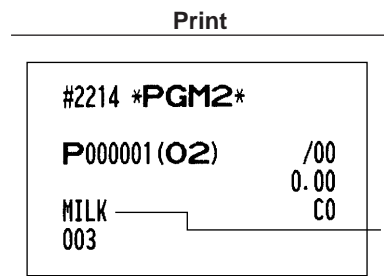
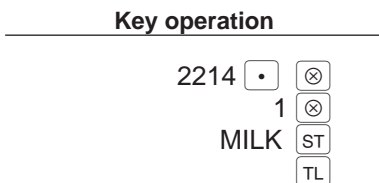

■ Assigning of PLUs to commission groups PGM 2 2215 2235

You can assign PLUs (or subdepartments) to commission groups.

Procedure

For each PLU

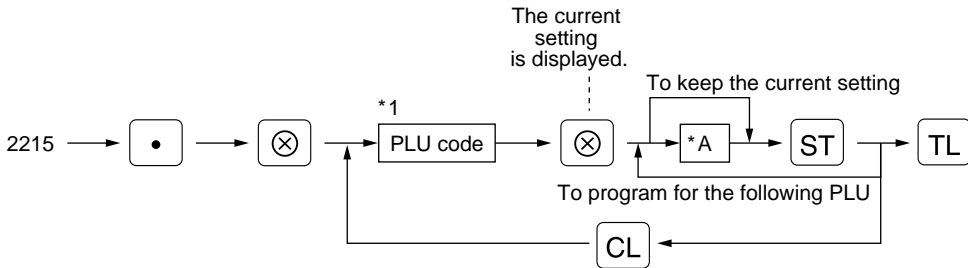

For a range of PLUs

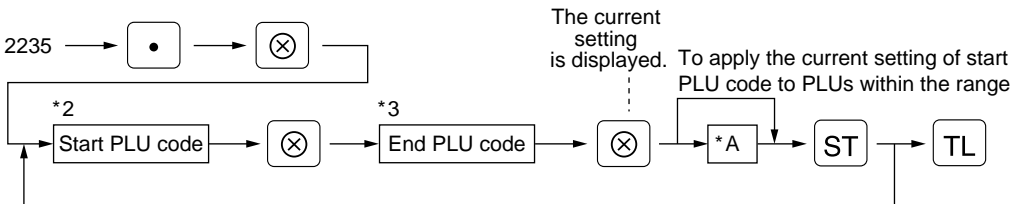

*1,2,3 : 1 through 999999

*A : Commission group 0-9 (0=no commission)

Example

For each PLU

Key operation

```
2215 . ⊗
      ⊗ 1 ⊗
           ⊗
           ⊗
           ⊗
```

Print

```
#2215 *PGM2*
P000001 (02) /00
              0.00
MILK          C1
003
```

Commission group number

For a range of PLUs

Key operation

```
2235 . ⊗
12 ⊗ 14 ⊗
      1 ⊗
           ⊗
           ⊗
```

Print

```
#2235 *PGM2*
P000012 -P000014
              C1
```

PLU range
Commission group number

■ Link PLU PGM 2 2220

Procedure

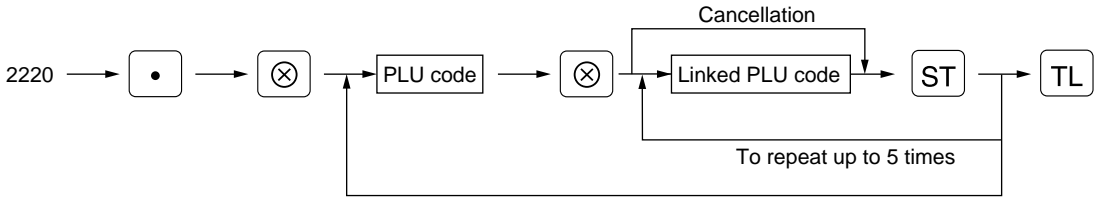

Note

- To program this function, please consult your dealer.
- PLU codes must have already been defined.

Example

Key operation

```

2220 • ⊗
21 ⊗ 25 ST
      26 ST
      27 ST
           TL
    
```

Print

```

#2220 *PGM2*

P000021      L P000025
              P000026
              P000027
    
```

Linked
PLU code

■ Direct PLU key positioning PGM 2 2219

You can assign a PLU code to each key position. PLUs may be selected for the number of direct PLU keys and their positions. For key number positions, refer to section “2 Standard key number layout” in the chapter “KEYBOARD”.

Procedure

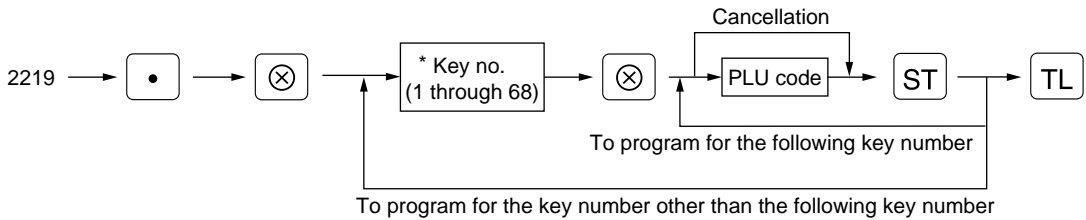

* The key number placement is determined by your local Authorized SHARP Dealer.

Example

Key operation

```

2219 • ⊗
      16 ⊗
      1  ST
           TL
    
```

Print

```

#2219 *PGM2*

016          P000001
    
```

Key no.
PLU code

6 Programming for miscellaneous keys

Only function keys which you have programmed on the keyboard will allow the programming.

■ Programming the rate (%, EX, commission) and the deduction (⊖) PGM 1

PGM 2 1310 Direct

You can program percent rates, currency exchange rates, deduction amounts and commission rates.

Procedure

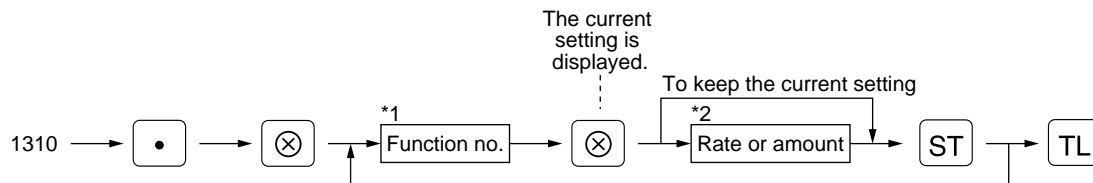

*1: Function no.

- | | | |
|-------------------|-------------------------------|-------------------------------|
| 1: For the ⊖ key | 8: For the %4 key | 74: For the commission sale 4 |
| 2: For the ⊖2 key | 52: For the EX1 key | 75: For the commission sale 5 |
| 3: For the ⊖3 key | 53: For the EX2 key | 76: For the commission sale 6 |
| 4: For the ⊖4 key | 54: For the EX3 key | 77: For the commission sale 7 |
| 5: For the %1 key | 71: For the commission sale 1 | 78: For the commission sale 8 |
| 6: For the %2 key | 72: For the commission sale 2 | 79: For the commission sale 9 |
| 7: For the %3 key | 73: For the commission sale 3 | |

*2: Rate or amount

- 0 — 999999 (Deduction amount)
- 0.00 — 100.00 (% rate)
- 0.000000 — 999.999999 (Currency exchange rate)
- 0.00 — 999.99 (Commission rate)

Example

Key operation

```

1310 • ⊗
  1 ⊗ 1000 ST
  5 ⊗ 10 • 25 ST
52 ⊗ 0 • 6068 ST
                    TL
    
```

Print

```

#1310 *PGM2*
F001 (-) 1
S          -10.00 — Deduction amount
                L17
F005 %1
S          -10.25% — Percent rate
                L100.00%
F052 EXCH1
                0.606800 — Currency exchange rate
    
```

Note

You must use a decimal point when setting percentages rates that are fractional.

■ A limit amount (HALO) of entry (⊖, RA, PO) PGM 2 2312 Direct

The HALO limit is in effect for the REG-mode operations but can be overridden in the MGR mode. The HALO limit is represented by two figures as follows:

Procedure

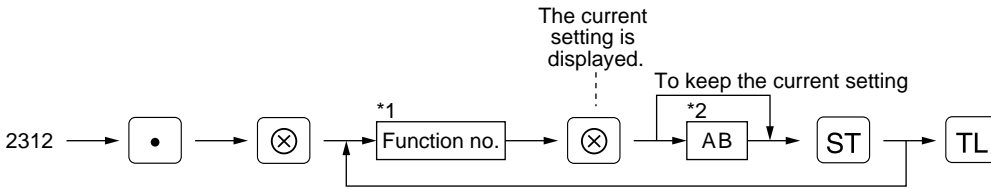

*1: Function no.

- | | |
|-------------------------------|---------------------------------|
| 1: For the ⊖ key | 37: For the RA key |
| 2: For the ⊖ ₂ key | 38: For the RA ₂ key |
| 3: For the ⊖ ₃ key | 39: For the PO key |
| 4: For the ⊖ ₄ key | 40: For the PO ₂ key |

*2: AB is the same as $A \times 10^B$.

A: Significant digit (0 through 9)

B: Number of zeros to follow significant digit

0 through 7 (for the ⊖ through ⊖₄ keys)

0 through 8 (for the RA, RA₂, PO, and PO₂ keys)

For example, presetting 13 (10.00) here means that amount entries of up to 10.00 are allowed in the REG mode.

You can set up AB = 17 for no limitation (for the ⊖ through ⊖₄ keys).

You can set up AB = 18 for no limitation (for the RA, RA₂, PO, and PO₂ keys).

Example

Key operation

```

2312 . ⊗
1 ⊗ 13 ST
      TL
    
```

Print

```

#2312 *PGM2*
F001 (→) 1
S          -10.00
           L13 — HALO limit
    
```

+/- sign (%, ⊖) PGM 2 2311 Direct

Programming of the +/- sign assigns the premium or discount function for each key.

Procedure

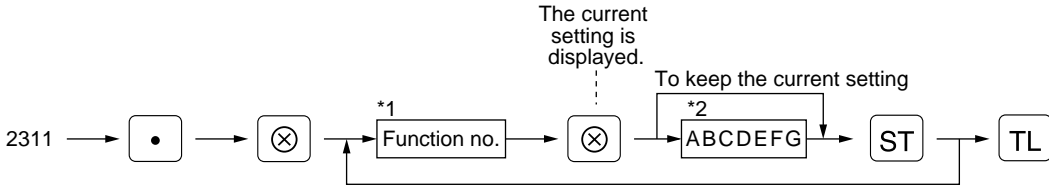

*1: Function no.

- 1: For the ⊖ key
- 2: For the ⊖2 key
- 3: For the ⊖3 key
- 4: For the ⊖4 key
- 5: For the %1 key
- 6: For the %2 key
- 7: For the %3 key
- 8: For the %4 key

*2:

Item:	Selection:	Entry:
A +/- sign	+ (premium) sign	0
	- (discount) sign	1
B to G	Always enter 0.	0

Example

Key operation

```

2311 . ⊗
5 ⊗ 000000 ST
6 ⊗ 100000 ST
TL
    
```

Print

```

#2311 *PGM2*

F005 %1
S          10.25%
L100.00%

F006 %2
S          -15.00%
L100.00%
    
```

"-": Discount

Item % or subtotal % selection (⊗) PGM 2 2315

Item %

Select this when a percent calculation is desired for the individual department and PLU.

Subtotal %

Select this when a percent calculation is desired for subtotals.

Procedure

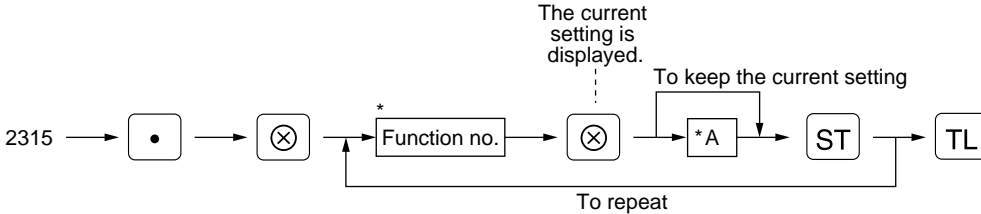

*: Function no.

- 5: For the key
- 6: For the key
- 7: For the key
- 8: For the key

*A:

- 0: Subtotal %
- 1: Item %

Example

Key operation

```
2315 • ⊗
5 ⊗ 1 ST
6 ⊗ 0 ST
TL
```

Print

```
#2315 *PGM2*
F005 %1
I      10.25%
      L100.00%
F006 %2
S      -15.00%
      L100.00%
```

Item %
Subtotal %

Percent rate limitation (⊗) PGM 2 2313

You can program the upper limit of percent rates for percent entries.

(Percent entries that exceed the upper limit may be overridden in the MGR mode.)

Procedure

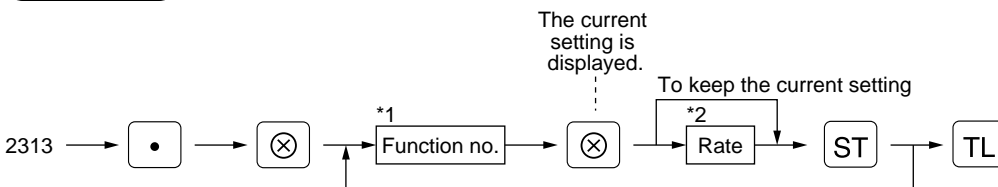

*1: Function no.

- 5: For the key
- 6: For the key
- 7: For the key
- 8: For the key

*2: Rate

0.00 – 100.00 (Entering 0.00 inhibits the open percent rate entry.)

Note 10.00% can be entered as or . The key is needed only for fractional entry.

Example

Key operation

2313
 5 15 00

Print

```
#2313 *PGM2*
F005 %1
I          10.25%
L 15.00% — Percentage limit
```

Item ⊖ or subtotal ⊖ selection (⊖) PGM 2 **2316**

Item ⊖

Select this when a deduction calculation is desired for the individual department and PLU.

Subtotal ⊖

Select this when a deduction calculation is desired for subtotals.

Procedure

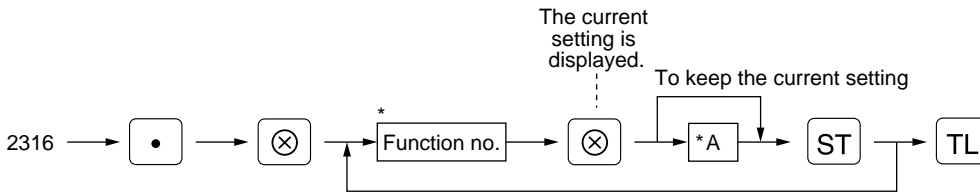

- *: Function no.
 1: For the ⊖ key
 2: For the ⊖2 key
 3: For the ⊖3 key
 4: For the ⊖4 key

- *A:
 0: Subtotal ⊖
 1: Item ⊖

Example

Key operation

2316
 1 1
 2 0

Print

```
#2316 *PGM2*
F001 (-) 1
I          -10.00
L13
F002 (-) 2
S          -15.00
L17 — Subtotal⊖
```

7 Programming for the **TL**, **CA2**, **CH1** through **CH4**, and **CR1** through **CR4** keys

■ Functional programming PGM 2 2320

You can set each media for:

EFT Transaction

For **CH1** through **CH4** keys, and **CR1** through **CR4** keys

Footer printing

This programming decides whether or not your machine should print a message at the foot of a receipt when a specified media key is used.

Non-add code compulsory

You can enforce the non-add code entry when a media entry is accepted.

Change enable (over-tender)

Either change enable or disable can be selected for a corresponding media key.

Drawer open

You can program each media key to or not to open the drawer.

Amount tendered compulsory

You may select amount tendered compulsory or optional for the **TL**, **CA2** and **CH1** through **CH4** keys.

You may select amount tendered compulsory or inhibited for the **CR1** through **CR4** keys.

Procedure

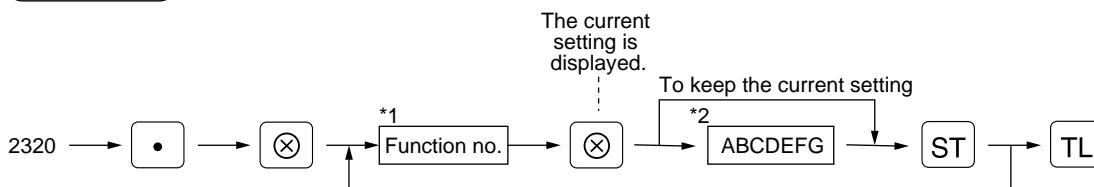

*1: Function no.

42: For the **TL** key

43: For the **CA2** key

44: For the **CH1** key

45: For the **CH2** key

46: For the **CH3** key

47: For the **CH4** key

48: For the **CR1** key

49: For the **CR2** key

50: For the **CR3** key

51: For the **CR4** key

*2 Item:

Selection:

Entry:

*2 Item:	Selection:	Entry:
A EFT transaction	Compulsory	1
	Non-compulsory	0
B Footer print	Yes	1
	No	0
C Non-add code	Compulsory	1
	Non-compulsory	0
D Change due	Disable	1
	Enable	0
E Always enter 0.		0
F Drawer open	No	1
	Yes	0
G Amount tendered entry	Compulsory	1
	Non-compulsory for TL, CA2 or CH1 through CH4 keys	0
	Inhibit for the CR1 through CR4 keys	0

Example

Key operation

2320
 50 0000001

Print

```
#2320 *PGM2*
F050 CREDIT3          L18
                        0000001
```

A through G

High amount lockout (HALO) for cheque change, cheque cashing, and cash in drawer PGM 2 2321

You can program the upper limit amounts for cheque change, cheque cashing, and cash in drawer.

Procedure

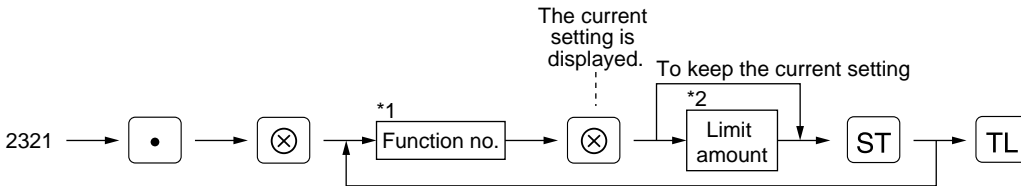

*1: Function no.
 41: For cheque cashing
 62: For cheque change
 59: For cash in drawer (Sentinel)

*2: Limit amount
 0 through 999999.99
 (Cheque change and cheque cashing)
 0 through 9999999.99 (Cash in drawer)

Example

Key operation

2321
 41 9999

Print

```
#2321 *PGM2*
F041 CA/CHK          99.99
```

HALO limit

High amount lockout (HALO) of entry for media keys PGM 2 2322 Direct

The HALO limit is in effect for REG-mode operations but can be overridden in the MGR mode. The HALO limit is represented by two figures as follows:

Procedure

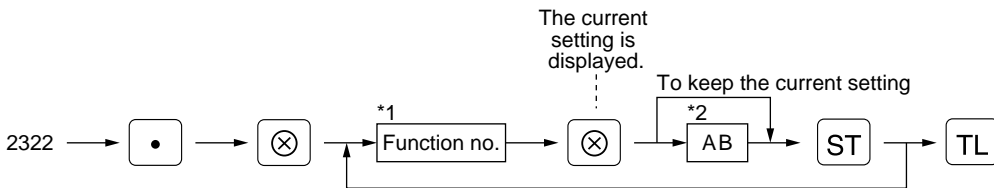

*1: Function no.
 42: For the key
 43: For the key
 44: For the key
 45: For the key
 46: For the key
 47: For the key

48: For the key
 49: For the key
 50: For the key
 51: For the key

*2: AB is the same as $A \times 10^B$.
 A: Significant digit (1 through 9)
 B: Number of zeros to follow significant digit
 (0 through 8)

You can set up AB = 18 for no limitation.

Example

Key operation

2322 [.] [⊗]
 50 [⊗] 15 [ST]
 [TL]

Print

```
#2322 *PGM2*
F050 CREDIT3      L15 HALO limit
                   0000001
```

8 Programming of function text

Programming PGM 2 2314

You can program a maximum of 8 characters for each function key and other functions using the table on the following pages. Select the characters you want to program referring to section “2 How to program alphanumeric characters” in chapter “PRIOR TO PROGRAMMING.”

Procedure

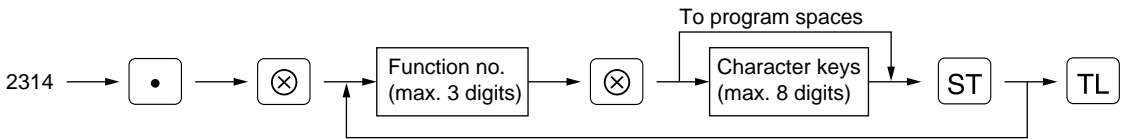

* Function no.: See “List of function texts” on the following pages.

Example

Key operation

2314 [.] [⊗]
 48 [⊗] VISA [ST]
 [TL]

Print

```
#2314 *PGM2*
F048 VISA      L18
                0000000
```

■ List of function texts

Function no.	Key or function	Default setting	Function no.	Key or function	Default setting
1	⊖ 1	(-)1	49	Credit 2	CREDIT2
2	⊖ 2	(-)2	50	Credit 3	CREDIT3
3	⊖ 3	(-)3	51	Credit 4	CREDIT4
4	⊖ 4	(-)4	52	Exchange 1	EXCH1
5	%1	%1	53	Exchange 2	EXCH2
6	%2	%2	54	Exchange 3	EXCH3
7	%3	%3	55	Exchange 4	EXCH4
8	%4	%4	56	Exchange 1 is	EXCH1 IS
9	Differ	DIFFER	57	Exchange 2 is	EXCH2 IS
10	Taxable 1 subtotal	TAX1 ST	58	Exchange 3 is	EXCH3 IS
11	Taxable 2 subtotal	TAX2 ST	59	Cash in drawer	**** CID
12	Taxable 3 subtotal	TAX3 ST	60	Cash/cheque is	CA/CH IS
13	Taxable 4 subtotal	TAX4 ST	61	Cash/cheque in drawer	CA/CH ID
14	Taxable 5 subtotal	TAX5 ST	62	Change for cheque	CHK/CG
15	Taxable 6 subtotal	TAX6 ST	63	Customer	GUEST
16	VAT/tax 1	VAT 1	64	Order total	ORDER TL
17	VAT/tax 2	VAT 2	65	Paid total	PAID TL
18	VAT/tax 3	VAT 3	66	Domestic currency 1	DOM.CUR1
19	VAT/tax 4	VAT 4	67	Domestic currency 2	DOM.CUR2
20	VAT/tax 5	VAT 5	68	Domestic currency 3	DOM.CUR3
21	VAT/tax 6	VAT 6	69	Domestic currency 4	DOM.CUR4
22	Net 1	NET1	70	Cheque in drawer	*CH ID
23	Net 2	NET2	71	Commission sale 1	COM.SAL1
24	Coupon-like PLU	CP PLU	72	Commission sale 2	COM.SAL2
25	Refund	REFUND	73	Commission sale 3	COM.SAL3
26	∞	∞	74	Commission sale 4	COM.SAL4
27	∞mode total	∞MODE	75	Commission sale 5	COM.SAL5
28	MGR ∞	MGR ∞	76	Commission sale 6	COM.SAL6
29	Subtotal ∞	SBTL ∞	77	Commission sale 7	COM.SAL7
30	Hash ∞	HASH ∞	78	Commission sale 8	COM.SAL8
31	Hash refund	HASH RF	79	Commission sale 9	COM.SAL9
32	VAT shift	VAT SFT	80	Non commission sale	NON.COM
33	VAT/tax delete	TAX DELE	81	(+) Dept total	*DEPT TL
35	No sale	NO SALE	82	(-) Dept total	DEPT (-)
36	Guest check counter	G.C. CNT	83	Hash (+) total	*HASH TL
37	RA	***RA	84	Hash (-) total	HASH (-)
38	RA2	***RA2	85	Bottle return (+) total	*BTTL TL
39	PO	***PO	86	Bottle return (-) total	BTTL (-)
40	PO2	***PO2	87	Net 1 (Taxable 1 - VAT/tax 1)	NET 1
41	Cheque cashing	CA/CHK	88	Net 2 (Taxable 2 - VAT/tax 2)	NET 2
42	Cash	CASH	89	Net 3 (Taxable 3 - VAT/tax 3)	NET 3
43	Cash 2	CASH2	90	Net 4 (Taxable 4 - VAT/tax 4)	NET 4
44	Cheque 1	CHECK	91	Net 5 (Taxable 5 - VAT/tax 5)	NET 5
45	Cheque 2	CHECK2	92	Net 6 (Taxable 6 - VAT/tax 6)	NET 6
46	Cheque 3	CHECK3	93	Subtotal	SUBTOTAL
47	Cheque 4	CHECK4	94	Merchandise subtotal	MDSE ST
48	Credit 1	CREDIT1	95	Difference subtotal	DIFF ST

Function no.	Key or function	Default setting	Function no.	Key or function	Default setting
96	Total	*** TOTAL	118	Commission amount 1	COM.AMT1
97	Change	CHANGE	119	Commission amount 2	COM.AMT2
98	Sales q'ty	ITEMS	120	Commission amount 3	COM.AMT3
99	PLU subtotal	PLU ST	121	Commission amount 4	COM.AMT4
100	Copy receipt title	COPY	122	Commission amount 5	COM.AMT5
101	Guest check copy title	G.C COPY	123	Commission amount 6	COM.AMT6
102	Average	AVE.	124	Commission amount 7	COM.AMT7
103	Group 1 for departments	GROUP01	125	Commission amount 8	COM.AMT8
104	Group 2 for departments	GROUP02	126	Commission amount 9	COM.AMT9
105	Group 3 for departments	GROUP03	127	Commission amount total	COM.TTL
106	Group 4 for departments	GROUP04	128	Department report title	DEPT
107	Group 5 for departments	GROUP05	129	Group report title	GROUP
108	Group 6 for departments	GROUP06	130	PLU report title	PLU
109	Group 7 for departments	GROUP07	131	Transaction report title	TRANS.
110	Group 8 for departments	GROUP08	132	Total in drawer report title	TL-ID
111	Group 9 for departments	GROUP09	133	Clerk report title	CLERK
112	CCD	CCD	134	Cashier report title	CASHIER
113	CCD differ	CCD DIF.	135	Hourly report title	HOURLY
114	CCD differ total	DIF. TL	136	Daily net report title	DAILY
115	Order total-Paid total	O - P	137	PLU zero sales report title	ZERO SAL
116	Total tax	TTL TAX	138	PLU price category report title	CATEGORY
117	Net without tax	NET	139	Commission sales report title	SALES

9 Cashier and clerk programming

■ Cashier code PGM 1 PGM 2 1500

You can assign a cashier code to each cashier. (If the cashier's file is upgraded, a maximum of 99 cashiers can be programmed. Consult your dealer.)

Procedure

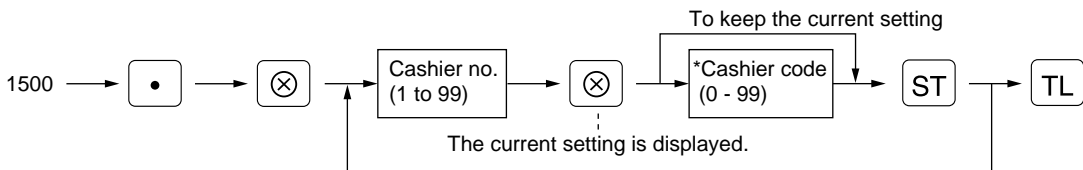

* Programming cashier code "0" inhibits entries of the cashier code.

Example

Key operation

```

1500 . ⊗
1 ⊗ 11 ST
4 ⊗ 14 ST
      TL

```

Print

```

#1500 *PGM2*
01CSR#          11
                0000D1
04CSR#          14
                0000D1

```

Cashier no.
Cashier code

■ Cashier name PGM 1 PGM 2 1514

You can program a maximum of 8 characters (cashier name) for each cashier. Select the characters you want to program referring to section "2 How to program alphanumeric characters" in chapter "PRIOR TO PROGRAMMING."

Procedure

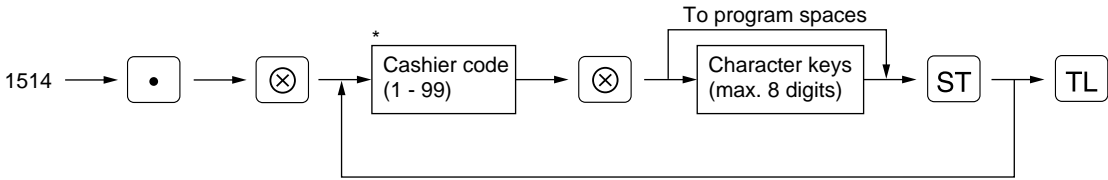

*: A cashier code you have programmed for the cashier by job code 1500

Example

Key operation	Print
1514 <input type="checkbox"/> <input type="checkbox"/> 11 <input type="checkbox"/> MAYER <input type="checkbox"/> <input type="checkbox"/> <input type="checkbox"/>	<pre>#1514 *PGM2* 01CSR# 11 MAYER 0000D1</pre>

■ Functional programming for cashiers PGM 2 2510

Procedure

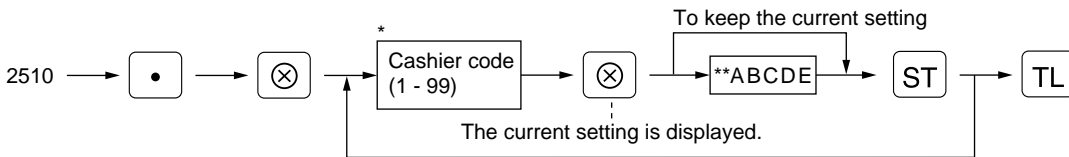

*: A cashier code you have programmed for the cashier by job code 1500

Item:	Selection:	Entry:
A Guest check copy	Disable	1
	Enable	0
B VAT shift	Yes	1
	No	0
C and D Always enter 0.		0
E Drawer	Set the drawer no. 1 or 2	1 or 2
	Use no drawer	0

Example

Key operation	Print
2510 <input type="checkbox"/> <input type="checkbox"/> 11 <input type="checkbox"/> 00001 <input type="checkbox"/> <input type="checkbox"/> <input type="checkbox"/>	<pre>#2510 *PGM2* 01CSR# 11 MAYER 0000D1</pre> <div style="margin-left: 150px;"> E(Drawer no.) A through D </div>

■ Clerk code PGM 1 PGM 2 1400

You can assign a clerk code to each of 99 clerks. The standard machine has no clerk function. If you need this function, consult your dealer.

Procedure

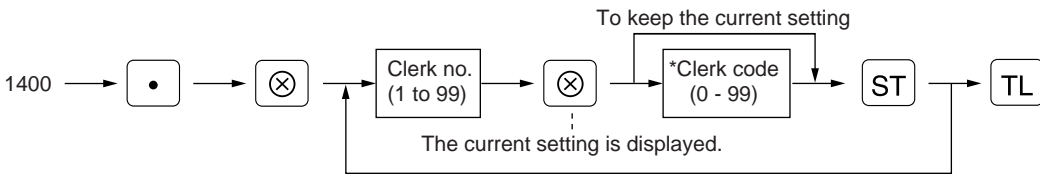

*: Programming clerk code "0" inhibits entries of the clerk code.

Example

Key operation

```

1400 . ⊗
1 ⊗ 11 ST
4 ⊗ 14 ST
      TL
    
```

Print

```

#1400 *PGM2*
01CLK#      11
04CLK#      14
    
```

Clerk no.
Clerk code

■ Clerk name PGM 1 PGM 2 1414

You can program a maximum of 8 characters (clerk name) for each clerk. Select the characters you want to program referring to section "2 How to program alphanumeric characters" in chapter "PRIOR TO PROGRAMMING."

Procedure

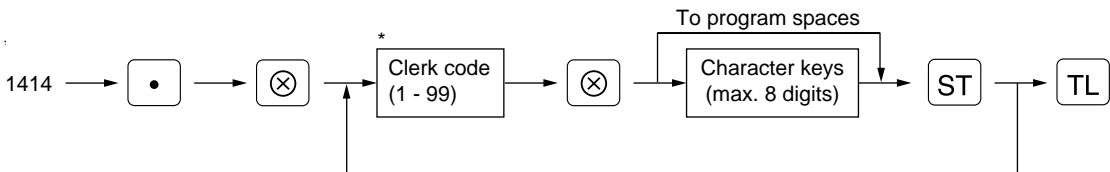

*: A clerk code you have programmed for the clerk by the job code 1400

Example

Key operation

```

1414 . ⊗
11 ⊗ NILS ST
      TL
    
```

Print

```

#1414 *PGM2*
01CLK# NILS      11
    
```

10 Programming various functions

■ Programming for optional feature selection

PGM 2

2616

OP X/Z mode availability

When a cashier needs to take the cashier/clerk X or Z report, he or she will use the OP X/Z mode. This programming determines whether he or she will be allowed to use this mode.

Note

You can take cashier/clerk X and Z reports in the X1/Z1 mode regardless of the above programming.

Paid out in the REG-mode

Refund key in the REG-mode

Direct void in the REG-mode

Indirect void in the REG-mode

Subtotal void in the REG-mode

First item direct void

Printing of the number of purchased items

Journal print form

You may choose either of the following forms.

- Detailed journal print that shows the details of all entries - the same information as printed on the receipt.
- Summary journal print that shows information about all entries other than normal department entries (entries into "+" departments and their associated "+" PLUs).

Zero skip for various reports

VAT/tax amount, taxable amount and net amount printing on the receipt/journal

VAT shift type

VAT shift by cashier: VAT shift is performed by the operation of a cashier who has been assigned to do the VAT shift operation (Refer to job# 2510).

VAT shift by shift key: VAT shift is performed by pressing the VAT shift key.

No sale in REG-mode

Finalization when the subtotal amount is zero in the REG mode

Printing of the exchange 1 total amount and change amount on the receipt/journal

Total and change amounts in exchange 1 currency are printed respectively below each of the total and exchange amounts in domestic currency.

Footer graphic logo printing

Credit counting when received-on-account/paid out finalized with the credit key

Separator line in the report

Link PLU printing on the receipt

Procedure

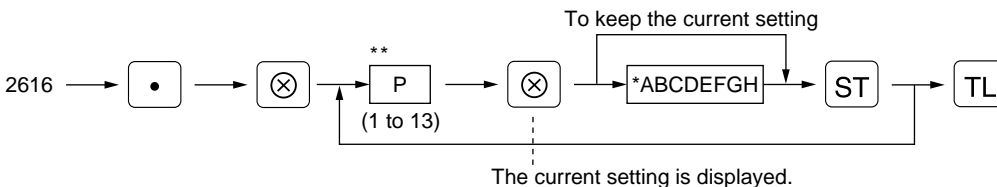

****P: 1**

* Item:	Selection:	Entry:
A OP X/Z mode	Enable	0
	Disable	1
B Paid-out in REG-mode	Enable	0
	Disable	1
C Always enter 0.		0
D Refund key entry in the REG-mode	Enable	0
	Disable	1
E Direct void in the REG-mode	Enable	0
	Disable	1
F Indirect void in the REG-mode	Enable	0
	Disable	1
G Subtotal void in the REG-mode	Enable	0
	Disable	1
H Always enter 0.		0

****P: 2**

* Item:	Selection:	Entry:
A The first item direct void	Enable	0
	Disable	1
B and C Always enter 0.		0
D Printing of the number of purchased items	No	0
	Yes	1
E Always enter 0.		0
F Journal print form	Detailed	0
	Limited	1
G and H Always enter 0.		0

****P: 3**

* Item:	Selection:	Entry:
A Always enter 0.		0
B Zero skip in clerk report	Yes	0
	No	1
C Zero skip in cashier report	Yes	0
	No	1
D Zero skip in transaction report	Yes	0
	No	1
E Zero skip in department report	Yes	0
	No	1
F Zero skip in PLU report	Yes	0
	No	1
G Zero skip in hourly report	Yes	0
	No	1
H Zero skip in daily net report	Yes	0
	No	1

**P: 4

* Item:	Selection:	Entry:
A and B Always enter 0.		0
C VAT/tax amount printing on the receipt/journal	Yes	0
	No	1
D Taxable amount printing on the receipt/journal	Yes	0
	No	1
E Net amount printing on the receipt/journal	Yes	0
	No	1
F to H Always enter 0.		0

**P: 5

* Item:	Selection:	Entry:
A to C Always enter 0.		0
D VAT shift type	By cashier	0
	By shift key	1
E to H Always enter 0.		0

**P: 6 (ABCDEFGH: Always enter 0.)

**P: 7

* Item:	Selection:	Entry:
A and B Always enter 0.		0
C No sale in REG-mode	Enable	0
	Disable	1
D Finalization in the REG-mode when the subtotal amount is zero	Enable	0
	Disable	1
E to H Always enter 0.		0

**P: 8 (ABCDEFGH: Always enter 0.)

**P: 9

* Item:	Selection:	Entry:
A to C Always enter 0.		0
D Printing exchange 1 total amount and change amount on receipt and journal	No	0
	Yes	1
E to G Always enter 0.		0
H Footer graphic logo printing	Yes	1
	No	0

**P: 10 to 12 (ABCDEFGH: Always enter 0.)

**P: 13

* Item:	Selection:	Entry:
A Credit counting when received-on-account/paid out is finalized with the credit key	Yes	1
	No	0
B Separator line in the report	Separator line	1
	1 line space	0
C Way to print the information for the link PLU on the receipt	Leading link PLU with total amount	1
	Each PLU	0
D to H Always enter 0.		0

Example

Key operation

2616
 3 00000010

Print

```
#2616 *PGM2*
03      00000010
P: 1 through 13
A through H
```

■ Programming feed line after printing of a difference subtotal PGM 2 2615

Procedure



- * A: Always enter 0.
- B: Feed lines after printing of difference subtotal (0 through 9)

Example

Key operation

2615
 01

Print

```
#2615 *PGM2*
01
```

■ Programming alarm length of time with drawer opening PGM 2 2617

If the drawer still remains open when a specified length of time has elapsed, your machine gives the alarm.

Procedure

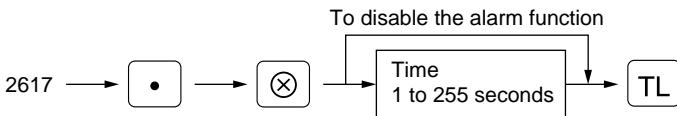

Example

Key operation

2617
 30

Print

```
#2617 *PGM2*
030
```

Note Your machine starts to monitor how long the drawer is kept open the moment the drawer is opened at the end of a transaction in the REG/VOID mode. It stops the time monitoring when a valid key (except the key) is pressed for the next transaction. It restarts the time monitoring after that transaction is ended. You can stop the buzzer alarm by closing the drawer. No key entries can be made while the buzzer is sounding.

■ Programming of logo messages PGM 2 2614

Your register can print programmed messages for customers on every receipt. On the standard model, only graphic logo is printed on the receipt. If you want to print logo message, please consult your dealer. You have five options described below.

Select the characters you want to program, referring to section “2 How to program alphanumeric characters” in chapter “PRIOR TO PROGRAMMING.”

Procedure

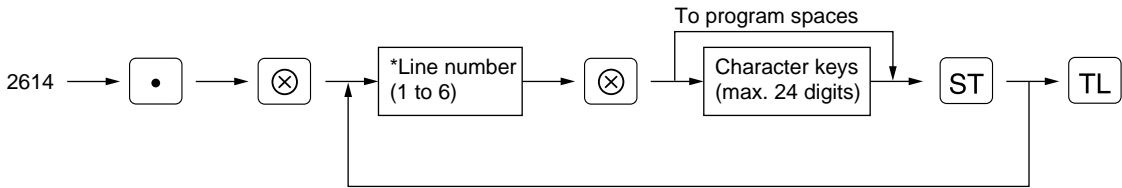

- * “Header 3-line message” type: 1 to 3
- “Footer 3-line message” type : 4 to 6
- “Header 6-line message” type: 1 to 6
- “Header 3-line and footer 3-line message” type: 1 to 6 (1 to 3 as header, 4 to 6 as footer)

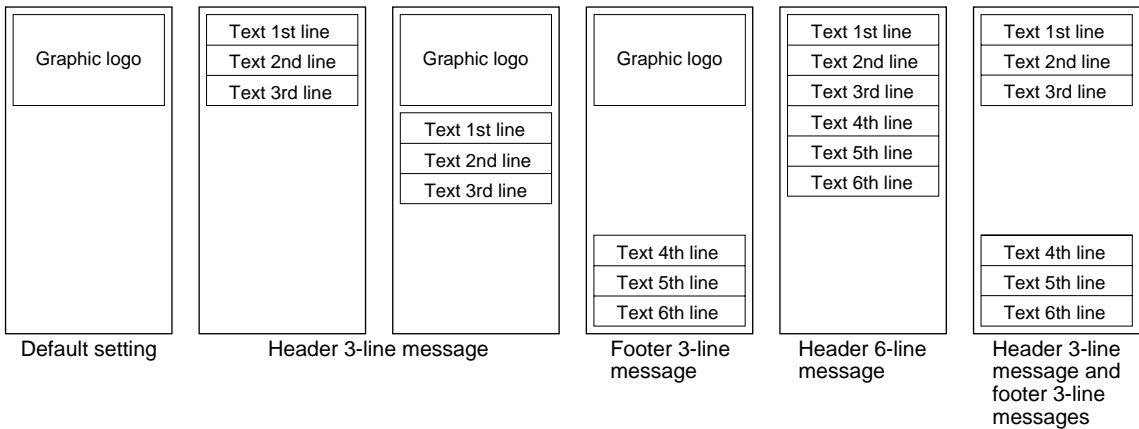

Example

To program the following logo messages by using 3 lines:

```
=== YOUR ===
== STORE ==
MESSAGE
```

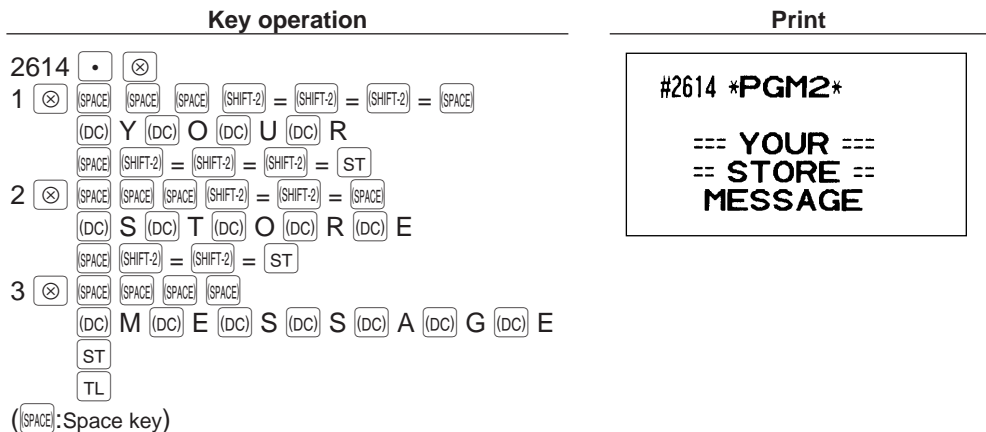

■ Selection of X1/Z1 and X2/Z2 reports to be printed in the stacked report sequence PGM 2 **2620**

Your register is equipped with the stacked report printing function that enables multiple X/Z reports to be printed in sequence with only a single request, up to maximum of 13 reports*. This function continuously prints a maximum of 13 kinds of reports with a single operation.

Procedure

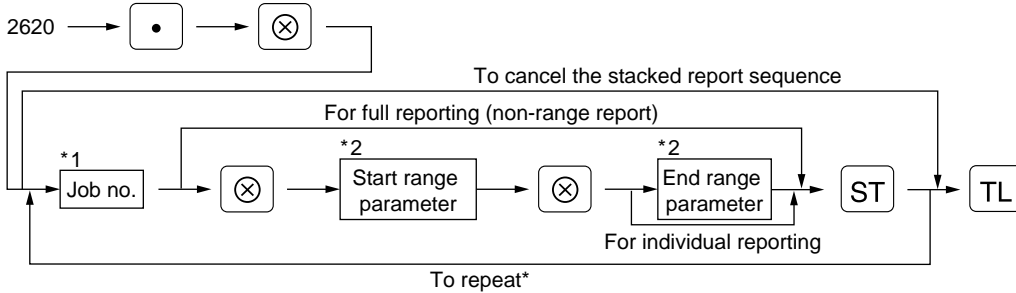

*: Maximum 70 steps are programmable. "1 step" means the memory size used for one no-range type job no. The range type job no. needs "8 steps".

Job code numbers to be used are as follows.

*1	Report	Available mode	Range parameter
00	General report		
10	Full department report	X1/X2 mode only	
13	Full department group report	X1/X2 mode only	
20	PLU report		*3 Start PLU code/end PLU code (1 through 999999)
27	PLU zero sales report	X1/X2 mode only	
29	PLU price category report	X1/X2 mode only	*3 Start price amount/end price amount
30	Transaction report	X1/X2 mode only	
31	Total in drawer report	X1/X2 mode only	
32	Commission sales report		
40	Full clerk report		
50	Full cashier report		
60	Hourly sales information	Range report is available only in the X1 mode.	*3 Start time/end time (0 through 2330)
70	Daily net report	X1/X2 mode only	

*3: Both range setting and full setting are allowed.

Note When Z of stacked report is initiated, X only reports will be skipped.

Example

Key operation

2620
 10
 13

Print

#2620 *PGM2*

10
13

■ Setting the time range for hourly reports PGM 2 **2619**

You can set the time range for an hourly report.

Procedure

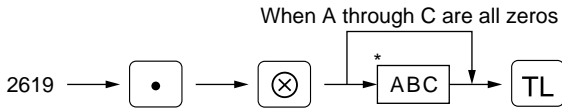

*A: Time range

To set the time range to 30 minutes (in the 24-hour system), enter 0.

To set the time range to 60 minutes (in the 24-hour system), enter 1.

BC: Starting time (hour = 00 to 23)

Example

Key operation

2619 [.] [⊗]
107 [TL]

Print

#2619 *PGM2*

1 07

Note To perform this setting, an hourly Z report (# 160) must be done.

■ RS-232C channel assignment PGM 2 **2690**

Your machine is equipped with an RS-232C interface. If you use the on-line communication function, the channel number of the RS-232C interface must be programmed by using the following procedure.

To realize the on-line communication, consult your dealer.

Procedure

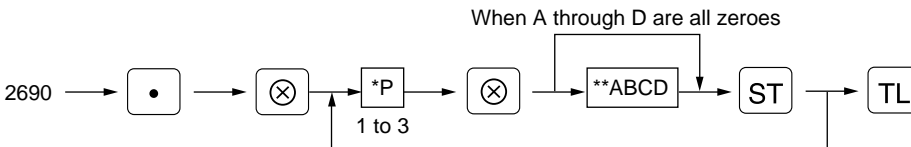

*P: 1

** Item:	Selection:	Entry:
A For the ON-LINE communication	Disable	0
	Enable (enter the channel number)	8
B to D Always enter 0.		0

*P: 2 and 3 (ABCD: Not used. Always enter 0.)

Example

Key operation

2690 [.] [⊗]
1 [⊗] [ST]
[TL]

Print

#2690 *PGM2*

1 0000
P
A through D

■ Secret codes to control access to PGM1 mode, X1/Z1 mode and X2/Z2 mode

PGM 2 **2630** **2631** **2632**

You must enter a secret code according to the following procedure before performing any PGM1-mode, X1/Z1-mode or X2/Z2-mode operation when a secret code has been set for that specific mode operation.

Operating

Procedure

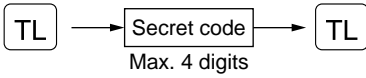

Note

Once a secret code is entered, it does not need to be entered again unless the mode switch setting is changed and any operation, such as a sales registration, reporting, or programming, is performed.

Programming

Procedure

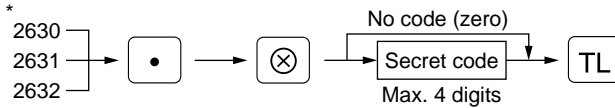

- * 2630 for the PGM1 mode
- 2631 for the X1/Z1 mode
- 2632 for the X2/Z2 mode

Example

Key operation

2631
1234

Print

#2631 *PGM2*

1234

■ Currency description text programming

PGM 2 **2334**

You can program a maximum of 4 characters for each of the through keys.

Procedure

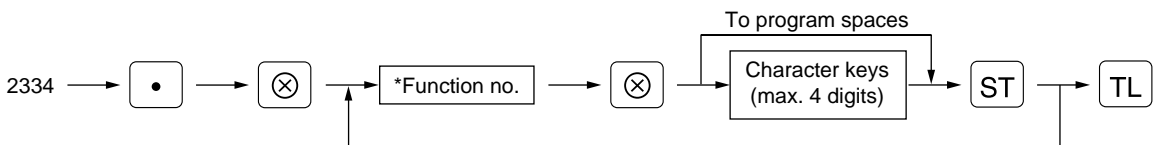

*Function no.:

- 52: For the key
- 53: For the key
- 54: For the key
- 55: For the key

Example

Key operation

2334
52
 DM

Print

#2334 *PGM2*

F052 EXCH1

DM

0.606800

■ Functional programming for the printer PGM 2 2990

You can program functions for the printer.

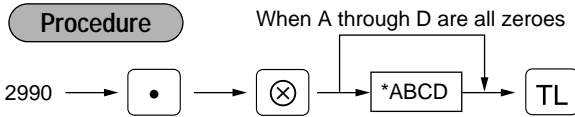

* Item:	Selection:	Entry:
A	Always enter 1.	1
B	Always enter 0.	0
C and D	Printing density (80% for standard=00 90% for standard=50 100% for standard=99)	00-99

Example

Key operation	Print
2990 [•] [⊗] 1050 [TL]	#2990 *PGM2* 1 0 50 <small>└─ Printing density</small>

■ Assigning the drawer number to the drawer for foreign currency PGM 2 2680

You can assign a number of the drawer which opens when one of the following operations is performed.

- One of [EX1] through [EX4] is pressed without any entry.
- A transaction is completed with a payment entry of foreign currency.
- An X/Z report is issued.

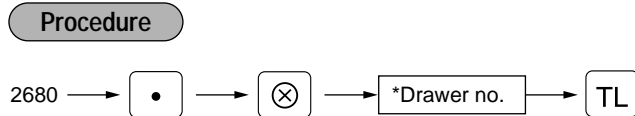

*Drawer no.:

- 0: Inhibit (No drawer opens.)
- 1: Drawer no. 1
- 2: Drawer no. 2

Example

Key operation	Print
2680 [•] [⊗] 2 [TL]	#2680 *PGM2* 2

Note To perform this programming, an optional drawer must be connected with your register.

■ Setting the AUTO key — Automatic sequencing key — X2/Z2 2900

If you program frequently performed transactions or report sequences for the AUTO keys, you can call those transactions and/or reports simply by pressing the corresponding AUTO keys in key operations. This programming can be done when your machine is in the X2/Z2 mode.

Procedure

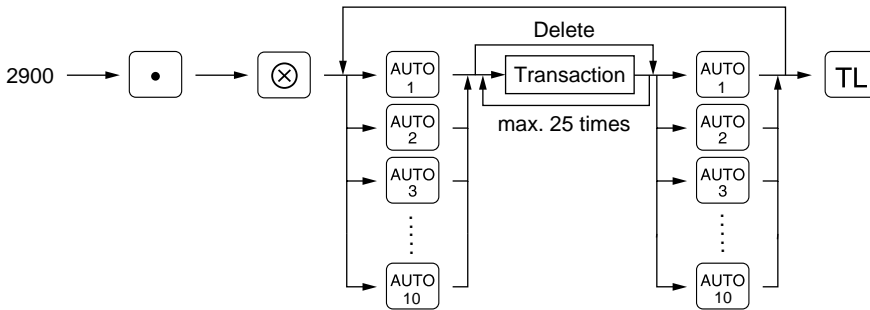

Example

Programming for **AUTO 1** key and **AUTO 2** key as follows:
AUTO 1; entering a PLU 2 item (programmed unit price: 1.50) and a dept. 6 item (unit price: 1.00)
AUTO 2; selling a dept. 7 item (programmed unit price: 5.00) for cash

Key operation	Print
2900 • ⊗	<div style="border: 1px solid black; padding: 10px;"> <p>#2900 *PGM2*</p> <p>#01</p> <p style="margin-left: 100px;">2 KEY</p> <p style="margin-left: 100px;">PLU</p> <p style="margin-left: 100px;">1 KEY</p> <p style="margin-left: 100px;">0 KEY</p> <p style="margin-left: 100px;">0 KEY</p> <p style="margin-left: 100px;">D06</p> <p>#02</p> <p style="margin-left: 100px;">D07</p> <p style="margin-left: 100px;">TOTAL</p> </div>
AUTO1 → 2 PLU/SUB 100 6	
AUTO2 setting → 7	
TL	
TL	

Note When the AUTO key has been programmed to execute a report job function etc., the mode switch must be in the appropriate position (X1/Z1 or X2/Z2).

11 Reading stored programs

Your machine allows you to read every program stored in the PGM1 and PGM2 modes.

Program details and procedures for their reading

Program for:	Mode switch position	Job code no.	Procedure	Related PGM1/ PGM2 job code nos.
1 Departments	PGM2 or PGM1	1100		1110, 2110, 2111, 2112, 2114, 2115, 2116
2 PLUs/ subdepartments	PGM2 or PGM1	1200		1200, 1210, 1211, 2210, 2211, 2214, 2215, 2230, 2231, 2232, 2235
3 Key nos. for departments and PLUs	PGM2	2119		2119, 2219
4 Link PLUs	PGM2	2220		2220
5 Cashiers	PGM2 or PGM1	1500		1500, 1514, 2510
6 Clerks	PGM2 or PGM1	1400		1400, 1414
7 Function preset 1	PGM2 or PGM1	1300		1310, 2311, 2312, 2313, 2314, 2315, 2316, 2320, 2321, 2322, 2334
8 Function preset 2	PGM2	2600		2614, 2615, 2616, 2617, 2619, 2620, 2630, 2631, 2632, 2680, 2690
9 Tax rates	PGM2	2700		2711
10 Auto keys	PGM2	2900		2900
11 Thermal printing	PGM2	2990		2990

■ Sample printouts

1 Reading of programmed items for departments (Reading in the PGM1 and PGM2 modes)

28/08/98 16:18 11		123456 #1151 MAYER		11 NILS	
Job code no.	#1100	*PGM2*		Mode switch position*	
Range		01-20			
Dept. code	D01	10.00		Unit price	
Item label	STEAK	G01		Group no.	
	0000003	C1L95		Tax status	
	D02 T1 3	0.00			
	DPT. 02	G02			
	0000001	C7L17		HALO limit.	
	D03	0.00		Commission group	
	DPT. 03	G03			
	0000003	C8L17		Function programming	
	D04 T1	0.00			
	DPT. 04	G04			
	0000001	C9L95		Type of unit price entry	0 0 0 0 0 0 3
				Type (SIF/SICS/Normal)	
	D09	0.00			
	DPT. 09	G01			
	0000001	C6L17			
	D10	-0.00		Minus department	
	DPT. 10	G10			
	0000001	C0L17			
	D20	0.00			
	DPT. 20	G01			
	0000001	C0L17			

2 Reading of programmed items for PLUs/subdepartments (Reading in the PGM1 and PGM2 modes)

28/08/98 16:24 11		123456 #1155 MAYER		11 NILS	
	#1200	*PGM2*		Mode switch position*	
		000001-000025		Range	
PLU code	P000001 (02)	/00		Unit price	
Tax status	T1	1.25			
Item label	MILK	C1		Associated dept. code	
	002			Base q'ty	
	P000002 (02)	/12			
	T1	2.00			
	PL000002	C2			
	003				0 0 3
	P000003 (01)	/00		Mode parameter	
		0.00			
	PL000003	C1		Commission group	
	003				
	P000004 (01)	/00			
		0.00			
	PL000004	C0			
	003				
	P000005 (01)	/00			
		0.00			
	P000020 (03)	/00			
	T1	0.00			
	PL000020	C0			
	003				
	P000021 (01) L	/00		Link PLU	
		3.50			
	PL000021	C0			
	003				
	P000022 (01)	/00			
		0.00			
	PL000022	C0			
	003				

* When you take this report in the PGM1 mode, the PGM2 indication is replaced by a "PGM1".

3 Reading of programmed key nos. for departments and PLUs
(Reading in the PGM2 mode)

28/08/98 17:27 11	
123456 #1176 MAYER	
11 NILS	
#2119 *PGM2*	
001	D01
002	D02
003	D03
004	D04
005	D05
006	D06
007	D07
008	D08
009	D09
010	D10
011	D11
012	D12
013	D13
014	D14
015	D15
016	P000001
017	D17
018	D18
019	D19
020	D20
021	----
022	----
023	----
024	----
025	----
026	----
027	----
028	----
029	----
030	----
031	----
032	----
033	----
034	----
035	----
036	----
037	----
038	----
039	----
040	----
041	----

066	----
067	----
068	----

4 Reading of programmed items for link PLUs
(Reading in the PGM2 mode)

28/08/98 17:29 11	
123456 #1177 MAYER	
11 NILS	
#2220 *PGM2*	
000001-999999	Range
P000021	Leading PLU code
L P000025	Linked PLU code
P000026	
P000027	

5 Reading of programmed items for cashiers
(Reading in the PGM1 and PGM2 modes)

28/08/98 17:35 11	
123456 #1181 MAYER	
11 NILS	
#1500 *PGM2*	
Cashier no.	01CSR# 11
Cashier name	MAYER 0000D1
	02CSR# 02
	03CSR# 03
	04CSR# 14
	TOM 0000D1

6 Reading of programmed items for clerks
(Reading in the PGM1 and PGM2 mode)

28/08/98 17:35 11	
123456 #1182 MAYER	
11 NILS	
#1400 *PGM2*	
Clerk no.	01CLK# NILS 11
Clerk name	02CLK# 02
	03CLK# 03
	04CLK# BETH 14

* When you take this report in the PGM1 mode, the PGM2 indication is replaced by a "PGM1".

7 Reading of programmed items for functions - 1
 (Reading in the PGM1 and PGM2 modes)

```

28/08/98 18:24      11
123456 #1196      MAYER
11 NILS

#1300 *PGM2*
F001 (-) 1
I          -10.00
          L13
F002 (-) 2
S          -15.00
          L17
F005 %1
S          -10.00%
          L 15.00%
F006 %2
I          15.00%
          L100.00%

F010 TAX1 ST
F011 TAX2 ST
F012 TAX3 ST
F013 TAX4 ST
F014 TAX5 ST
F015 TAX6 ST
F016 VAT 1
F017 VAT 2
F018 VAT 3
F019 VAT 4
F020 VAT 5
F021 VAT 6
F022 NET 1
F023 NET 2
F024 CP PLU
F025 REFUND
F026 ∞
F027 ∞ MODE
F028 MGR ∞
F029 SBTL ∞
F030 HASH ∞
F031 HASH RF
F032 VAT SFT
F033 TAX DELE
F035 NO SALE
F036 G.C. CNT
F037 ***RA          L18
F039 ***PO          L18
F041 CA/CHK
          99.99
F042 CASH          L18
          0000000
  
```

Mode switch
position*

```

F044 CHECK          L18
          0000000
F045 CHECK2         L18
          0000000
F048 CREDIT1        L18
          0000000
F049 CREDIT2        L15
          0000000
F050 CREDIT3        L15
          0000001
F052 EXCH1          DM
          0.606800
F053 EXCH2          L15
          0.000000
F055 EXCH4
F059 ****CID       9999999.99
F061 CA/CH ID
F062 CHK/CG       9999999.99
F063 GUEST
F064 ORDER TL
F065 PAID TL
F066 DOM. CUR1
F067 DOM. CUR2
F069 DOM. CUR4
F070 *CH ID
F071 COM. SAL1
          0.00%
F072 COM. SAL2
          0.00%
F073 COM. SAL3
          0.00%
F074 COM. SAL4
          0.00%
F075 COM. SAL5
          0.00%
F076 COM. SAL6
          0.00%
F077 COM. SAL7
          0.00%
F078 COM. SAL8
          0.00%
F079 COM. SAL9
          0.00%
F080 NON COM.
F081 *DEPT TL
F082 DEPT (-)
F083 *HASH TL
F084 HASH (-)
F085 *BTTL TL
F086 BTTL (-)
  
```

To be continued on the next page

* When you take this report in the PGM1 mode, the PGM2 indication is replaced by a "PGM1".

8 Reading of programmed items for functions - 2
(Reading in the PGM2 mode)

F087 NET 1
 F088 NET 2
 F089 NET 3
 F090 NET 4
 F091 NET 5
 F092 NET 6
 F093 SUBTOTAL
 F094 MDSE ST
 F095 DIFF ST
 F096 ***TOTAL
 F097 CHANGE
 F098 ITEMS
 F099 PLU ST
 F100 **COPY**
 F101 G. C COPY
 F102 AVE.
 F103 **GROUP01**
 F104 **GROUP02**
 F105 **GROUP03**
 F106 **GROUP04**
 F107 **GROUP05**
 F108 **GROUP06**
 F109 **GROUP07**
 F110 **GROUP08**
 F111 **GROUP09**
 F115 **O-P**
 F116 TTL TAX
 F117 **NET**
 F118 COM. AMT1
 F119 COM. AMT2
 F120 COM. AMT3
 F121 COM. AMT4
 F122 COM. AMT5
 F123 COM. AMT6
 F124 COM. AMT7
 F125 COM. AMT8
 F126 COM. AMT9
 F127 COM. TTL
 F128 **DEPT**
 F129 **GROUP**
 F130 **PLU**
 F131 **TRANS.**
 F132 **TL-ID**
 F133 **CLERK**
 F134 **CASHIER**
 F135 **HOURLY**
 F136 **DAILY**
 F137 **ZERO SAL**
 F138 **CATEGORY**
 F139 **SALES**

28/08/98 17:51	11	
123456 #1192	MAYER	
11 NILS		
#2600 *PGM2*		
#2614		Logo message
	=== YOUR ===	
	== STORE ==	
	MESSAGE	
#2615	01	
#2616		Line feed for differ ST
01	00000000	Optional feature selection
02	00000000	
03	00000010	
04	00000000	
05	00000000	
06	00000000	
07	00000000	
08	00000000	
09	00000000	
10	00000000	
11	00000000	
12	00000000	
13	00100000	
#2617	030	Drawer open alarm time
#2619	0 09	Hourly report format/start hour
#2620		
	10	Stacked report
	13	
#2630	0000	Secret code
#2631	1234	
#2632	0000	
#2680	2	Drawer no. for the drawer for foreign currency
#2690		
1	0000	RS-232C channel data
2	0000	
3	0000	

9 Reading of programmed tax rates
(Reading in the PGM2 mode)

28/08/98 17:53 11	
123456 #1193 MAYER	
11 NILS	
#2700 *PGM2*	
TAX1	5.0000%
	0.12
TAX2	4.0000%
	0.12
TAX3	6.0000%
	0.20
TAX4	----
TAX5	----
TAX6	----

Tax rate
Lowest taxable amount

11 Reading of programmed items for the thermal printer
(Reading in the PGM2 mode)

28/08/98 17:55 11	
123456 #1195 MAYER	
11 NILS	
#2990 *PGM2*	
	1 0 50
10 :	0123456789ABCDEF
20 :	0123456789ABCDEF
30 :	0123456789ABCDEF
40 :	0123456789ABCDEF
50 :	0123456789ABCDEF
60 :	0123456789ABCDEF
70 :	0123456789ABCDEF
80 :	0123456789ABCDEF
90 :	0123456789ABCDEF

Printing density
Entered Value
Printing density example

10 Reading of programmed items for auto keys
(Reading in the PGM2 mode)

28/08/98 17:53 11	
123456 #1194 MAYER	
11 NILS	
#2900 *PGM2*	
#01	2 KEY
	PLU
	1 KEY
	00 KEY
	D06
#02	D07
	TOTAL
#03	----
#04	----
#10	----

12 Training mode

The training mode is used when the operator or the manager practices register operations.

When a cashier set in training is selected, the machine automatically enters the training mode. When a cashier not set in training is selected, the machine automatically enters the ordinary REG mode. (For programming, consult your dealer.)

The training operations is valid only in REG, MGR and VOID mode.

The corresponding cashier memory is updated in the training mode. Other memories are not updated.

Key operation	Print
1000 <input type="button" value="5"/>	<div style="border: 1px solid black; padding: 5px;"><p>28/08/98 17:59 14 123456 #1195 TOM 14 BETH</p><p>TRAINING</p><p>DPT.05 *10.00 3x 24.00 DPT.03 *72.00</p><p>CASH *82.00</p></div>
3 <input type="button" value="⊗"/>	
<input type="button" value="3"/>	
<input type="button" value="TL"/>	

READING (X) AND RESETTING (Z) OF SALES TOTALS

- Use the reading function (X) when you need to take a reading of sales information entered since the last resetting. You can take this reading any number of times. It does not affect the register's memory.
- Use the resetting function (Z) when you need to clear the register's memory. Resetting prints all sales information and clears the entire memory except for the GT1 through GT3, reset count, and consecutive number.

1 Summary of reading (X) and resetting (Z) reports and the key operations to obtain the reports

X1 and Z1 reports: Daily sales reports

X2 and Z2 reports: Periodic (monthly) consolidation reports

Item	Mode switch position		Job code	Key operation
	X1/Z1	X2/Z2		
Flash report: (Only display) To clear the display, press the CL key or turn the mode switch to another position.	X1	—	—	Dept. key (1 to 50) : Department total amount
				⊗ key: Amount of cash in drawer
				ST key: Sales total
Full reading and resetting	X1, Z1	X1, Z1	100	100 → Reading → ⊗ → TL 200 → Resetting → ⊗ → TL
		X2, Z2	200	
Individual clerk reading and resetting	X1, Z1	X1, Z1	141	141 → Reading → ⊗ → TL 241 → Resetting → ⊗ → TL
		X2, Z2	241	
	<OP X/Z> X, Z		41	41 → Reading → ⊗ → TL → Resetting → ⊗ → TL
Individual cashier reading and resetting	X1, Z1	X1, Z1	151	151 → Reading → ⊗ → TL 251 → Resetting → ⊗ → TL
		X2, Z2	251	
	<OP X/Z> X, Z		51	51 → Reading → ⊗ → TL → Resetting → ⊗ → TL
Full clerk reading and resetting	X1, Z1	X1, Z1	140	140 → Reading → ⊗ → TL 240 → Resetting → ⊗ → TL
		X2, Z2	240	
Full cashier reading and resetting	X1, Z1	X1, Z1	150	150 → Reading → ⊗ → TL 250 → Resetting → ⊗ → TL
		X2, Z2	250	
Full department reading	X1	X1	110	110 → ⊗ → TL
		X2	210	210 → ⊗ → TL
Individual group reading	X1	X1	112	112 → ⊗ → Group no. → TL
		X2	212	212 → ⊗ → TL
Full group reading	X1	X1	113	113 → ⊗ → TL
		X2	213	213 → ⊗ → TL

Item	Mode switch position		Job code	Key operation
	X1/Z1	X2/Z2		
Commission sales report	X1	X1	132	132 → ⊗ → TL 232 → ⊗ → TL
		X2	232	
Reading and resetting of sales information for a range of PLUs/subdepartments	X1, Z1	X1, Z1	120	
		X2, Z2	220	
Reading of sales information of PLUs/subdepartments associated with an individual department	X1	X1	121	121 → ⊗ → Dept. code → TL 221 → ⊗ → TL
		X2	221	
Reading of sales information on PLUs/subdepartments whose sales amounts are zeros	X1	X1	127	127 → ⊗ → TL 227 → ⊗ → TL
		X2	227	
Reading of sales information for the price amount range of PLUs/sub department	X1	X1	129	
		X2	229	
Transaction reading	X1	X1	130	130 → ⊗ → TL 230 → ⊗ → TL
		X2	230	
Total in drawer	X1	X1	131	131 → ⊗ → TL 231 → ⊗ → TL
		X2	231	
Reading and resetting of hourly sales information	X1		160	
		X1, Z1		
Reading and resetting of a stacked report	X1, Z1	X1, Z1	190	
		X2, Z2	290	
Reading and resetting of the daily net totals		X2, Z2	270	270 → Reading → ⊗ → TL Resetting

Note Individual and full clerk reading and resetting are available only in the cashier and clerk system. In the factory setting, the register provides the "cashier only" system. So, if you want to change the system, consult your dealer.

2 Automatic modification of register system for introduction of EURO

To make your register correspond to the introduction of EURO, your register system can be automatically modified when the procedure shown below is executed in the Z2 mode.

Procedure

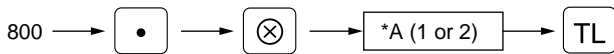

*A=1: Applicable for the period of co-existence of EURO and national currency. (During the transition period)

*A=2: Applicable for the time the national currency is withdrawn from circulation. (At the completion of transition period.)

Note

- You can perform the each operation only once with the substitution of "A=1" and "A=2". If you performed the operation with the substitution of "A=2" first, you cannot perform the operation with the substitution of "A=1".
- After the execution of the procedure above, EURO is treated as domestic currency, and National currency as foreign currency. Program the rate of national currency for EURO to the exchange 1(EX1) key.

The details of the register system modification are as follows:

When "1" is substituted to "A":

1. Issuing a general Z1 report (Job #100).
2. Issuing a general Z2 report (Job #200).
3. Resetting GT1, GT2 and GT3.
4. Setting "Yes" for a PGM function "Printing exchange 1 total amount and change amount on receipt and journal" (Job #2616)
5. Changing the domestic currency symbol to EURO symbol.

When "2" is substituted to "A":

1. Issuing a general Z1 report (Job #100).
2. Issuing a general Z2 report (Job #200).
3. Resetting GT1, GT2 and GT3.
4. Setting "No" for a PGM function "Printing exchange 1 total amount and change amount on receipt and journal" (Job #2616)
5. Changing the domestic currency symbol to EURO symbol.

Note

When the operation with the substitution of "A=1" has been performed already, only 1, 2, and 4 are executed.

3 Daily sales totals

Full reading and resetting of sales totals

You can take X and Z reports in the X1/Z1 mode. The use of the decimal key (\square) determines when the report will actually reset the sales totals.

• Sample X report

29/08/98 20:40	11		
123456 #1434	MAYER		
11 NILS			
#100 *X1*			
TR	*00000000167.29		
DEPT			
D01	615.000 Q		
DPT. 01	*1396.42		
	55.02%		
D05	30.000 Q		
DPT. 05	*43.20		
	1.70%		
D06	37.000 Q		
DPT. 06	*288.19		
	11.35%		
D07	49.000 Q		
DPT. 07	*391.75		
	15.43%		
D09	27.000 Q		
DPT. 09	*145.02		
	5.71%		
GROUP01	798.000 Q		
	*2538.20		
	65.93%		
D02	128.000 Q		
DPT. 02	*890.04		
	100.00%		
GROUP02	128.000 Q		
	*890.04		
	23.12%		
*DEPT TL	991.000 Q		
	*3849.91		
	100.00%		

• Sample Z report

30/08/98 9:15	11		
123456 #1523	MAYER		
11 NILS			
#100 *Z1*			
	Z1 0003		
GT1	*00000007832.46		
GT2	*00000061915.39		
GT3	-00000054082.93		
TR	*00000000167.29		

The subsequent printout occurs in the same format as in the X report.

To be continued on the next page

Note Not all reports provide the resetting capability. Please refer to the chart on pages 73 and 74.

D10	15.000 Q	
DPT. 10	-55.72	
DEPT (-)	15.000 Q	} "-" dept. counter and total
	-55.72	
D11	77.000 Q	
DPT. 11	*181.26	
*HASH TL	77.000 Q	} "+" hash dept. counter and total
	*181.26	
D12	2.000 Q	
DPT. 12	-27.00	
HASH (-)	2.000 Q	} "-" hash dept. counter and total
	-27.00	
D13	40.000 Q	
DPT. 13	*14.75	
*BTTL TL	40.000 Q	} "+" bottle return dept. counter and total
	*14.75	
D14	18.000 Q	
DPT. 14	-6.90	
BTTL (-)	18.000 Q	} "-" bottle return dept. counter and total
	-6.90	
* TRANS. *		
(-) 2	4 Q	
	-5.00	} Subtotal ⊖2 counter and total
%1	4 Q	
	-4.84	} Subtotal percent 1 counter and total
NET 1	*3792.20	— Net sales total
TAX1 ST	*1031.02	— Taxable 1 total
VAT 1	*49.10	— VAT 1 total
TAX2 ST	*5.50	
VAT 2	*0.21	
TAX3 ST	*824.17	
VAT 3	*46.65	
TTL TAX	*95.96	— Tax total
NET	*3696.24	— Net total without tax
VAT SFT	*5.50	— VAT shift total
(-) 1	3 Q	
	-2.50	} Item ⊖1 counter and total
%2	4 Q	
	*3.53	} Item percent 2 counter and total
REFUND	5 Q	
	*34.40	} Refund counter and total
∞	9 Q	
	*37.90	} REG-mode void counter and total
∞ MODE	3 Q	
	*53579.00	} Void-mode transaction counter and total
MGR ∞	5 Q	
	*53579.00	} Manager item void counter and total
SBTL ∞	3 Q	
	*139.28	} Subtotal void counter and total
HASH ∞	1 Q	
	*9000.00	} Hash dept. void counter and total

To be continued on the next page

NO SALE	3 Q	No-sale (exchange) counter
G. C. CNT	2 Q	Gest check copy counter
GUEST	158 Q	Customer counter
ORDER TL	*3946.46	Order total
PAID TL	*3946.46	Paid total
AVE.	*24.98	Paid total average per costomer
***RA	2 Q	} Received on account counter and total
	*63.00	
***PO	2 Q	} Paid out counter and total
	*80.00	
CA/CHK	2 Q	} Cheque cashing counter and total
	*50.00	
CASH	131 Q	} Cash counter and total
	*2569.73	
CHECK	7 Q	} Cheque 1 sales counter and total
	*131.65	
CHECK2	1 Q	} Credit 1 sale and tendering counter and total
	*100.00	
CREDIT1	7 Q	} Credit 1 sale and tendering counter and total
	*288.21	
CREDIT2	2 Q	} Exchange 1 counter and total
	*83.30	
EXCH1	3 Q	} Exchange 1 counter and total
	170.00	
DOM. CUR1	*280.12	
EXCH2	5 Q	
	240.00	
DOM. CUR2	*523.76	
EXCH3	1 Q	
	20.00	
DOM. CUR3	*32.96	
EXCH4	3 Q	
	300.00	
DOM. CUR4	*494.19	
****CID	*1912.27	Cash in drawer
*CH ID	*314.65	Cheque in drawer
CA/CH ID	*2226.92	Cash + cheque in drawer
CHK/CG	*14.50	Change total for cheque tendering

■ Cashier reading and resetting

Using this function, you can take X and Z reports for individual cashiers or all cashiers.

Individual cashier reading and resetting

Note

The OP X/Z-mode reading and resetting is allowed only when your machine has been programmed for "OP X/Z mode available" in the PGM2 mode.

• Sample X report

```

29/08/98 20:15      11
123456 #1404    MAYER
11 NILS

#151 *X1*
*CASHIER *
01CSR#11 MAYER
ORDER TL      *5668.37
PAID TL       *5667.37
AVE.          *26.48
REFUND        8 Q
              *54.10
S             19 Q
              *9087.18
S MODE        4 Q
              *50160.00
MGR S         8 Q
              *50160.00
SBTL S        5 Q
              *190.23
GUEST         214 Q

***RA         3 Q
              *111.00
***PO         3 Q
              *110.00
CA/CHK        3 Q
              *80.00

CASH          187 Q
              *4467.21
CHECK         10 Q
              *161.80
CHECK2        1 Q
              *100.00
CREDIT1       9 Q
              *360.71
CREDIT2       3 Q
              *123.30
EXCH1         5 Q
DM370.00
DOM. CUR1     *609.68
EXCH2         1 Q
              30.00
DOM. CUR2     *49.41

***CID        *3803.01
*CH ID        *392.80
CA/CH ID      *4195.81
CHK/CG        *17.15
    
```

Cashier no./cashier code
 Cashier name
 Order total
 Paid total
 Average

• Sample Z report

```

30/08/98 9:16      11
123456 #1524    MAYER
11 NILS

#151 *Z1*
*CASHIER *
01CSR#11 MAYER
    
```

The subsequent printout occurs in the same format as in the sample X report.

Full cashier reading and resetting

```

29/08/98 20:23      11
123456 #1405    MAYER
11 NILS

#150 *X1*
*CASHIER *
    
```

```

30/08/98 9:18      11
123456 #1525    MAYER
11 NILS

#150 *Z1*
*CASHIER *
    
```

The subsequent printout occurs in the same format as in the sample reports of individual cashier reading and resetting, and sales data for cashiers print in this sequence.

■ Clerk reading and resetting

Using this function, you can take X and Z reports for individual clerks or all clerks.

Individual clerk reading and resetting

Note

The OP X/Z-mode reading and resetting is allowed only when your machine has been programmed for "OP X/Z mode available" in the PGM2 mode.

• Sample X report

29/08/98 20:24	11	
123456 #1406	MAYER	
11 NILS		
#141 *X1*		
* CLERK *		
01CLK#1 1	NILS	Clerk no./clerk code
ORDER TL	*5666.97	Clerk name
COM. SAL1	*1037.05	Order total
COM. SAL2	*106.80	Commission sales
COM. SAL3	*66.72	1 total amount
COM. SAL4	*83.06	
COM. SAL5	*145.28	
COM. SAL6	*38.94	
COM. SAL7	*105.80	
COM. SAL8	*29.07	
COM. SAL9	*45.69	
NON COM.	*4020.41	Non-commission sales amount

• Sample Z report

30/08/98 9:19	11
123456 #1526	MAYER
11 NILS	
#141 *Z1*	
* CLERK *	

The subsequent printout occurs in the same format as in the sample X report.

Full clerk reading and resetting

29/08/98 20:25	11
123456 #1407	MAYER
11 NILS	
#140 *X1*	
* CLERK *	

30/08/98 9:19	11
123456 #1527	MAYER
11 NILS	
#140 *Z1*	
* CLERK *	

The subsequent printout occurs in the same format as in the reports of individual clerk reading and resetting, and sales data for clerks print in this sequence.

* When you take these reports in the OP X/Z mode, the X report shows an "OP X" and the Z report shows an "OP Z".

■ Reading and resetting of hourly sales information

You can take X and Z reports for sales totals and transaction (customer) counters for 48 half hours, or 24 hours. If both quantity and amount are zero, their print is skipped.

• Sample X report

29/08/98 19:57	11	
123456 #1518	MAYER	
11 NILS		
#160 *X1*		
* HOURLY *		
10:00	13 Q	Customer counter
	*346.05	Sales total
AVE.	*26.62	Average sales amount per customer
10:30	3 Q	(sales total ÷ customer counter)
	*52.23	
AVE.	*17.41	
SUBTOTAL	16 Q	
	*398.28	
11:00	25 Q	
	*231.72	
AVE.	*9.27	
11:30	4 Q	
	*68.45	
AVE.	*17.11	
SUBTOTAL	29 Q	
	*300.17	
12:00	46 Q	
	*1258.77	
AVE.	*27.36	
12:30	39 Q	
	*1554.41	
AVE.	*39.86	
SUBTOTAL	85 Q	
	*2813.18	

• Sample Z report

30/08/98 9:19	11
123456 #1528	MAYER
11 NILS	
#160 *Z1*	
* HOURLY *	

The subsequent printout occurs in the same format as in the sample X report.

17:30	11 Q
	*475.85
AVE.	*43.26
SUBTOTAL	22 Q
	*776.01
18:00	20 Q
	*374.21
AVE.	*18.71
18:30	30 Q
	*291.36
AVE.	*9.71
SUBTOTAL	50 Q
	*665.57

■ Full department reading

29/08/98 20:26	11	
123456 #1408	MAYER	
11 NILS		
#110 *X1*		
DEPT		
D01	600.000 Q	} Sales q'ty and total
DPT. 01	*1254.42	
	56.15%	} Ratio of dept. 1 sales amount to "+" dept. total
D05	30.000 Q	
DPT. 05	*43.20	
	1.93%	
D06	34.000 Q	
DPT. 06	*219.19	
	9.81%	
D07	46.000 Q	
DPT. 07	*313.25	
	14.02%	
D08	37.000 Q	
DPT. 08	*259.07	
	11.60%	
D09	27.000 Q	
DPT. 09	*145.02	
	6.49%	
GROUP01	774.000 Q	
	*2234.15	
	67.20%	
D02	123.000 Q	
DPT. 02	*724.02	
	100.00%	
GROUP02	123.000 Q	
	*724.02	
	21.78%	
D03	39.000 Q	
DPT. 03	*232.92	
	100.00%	
GROUP03	39.000 Q	
	*232.92	
	7.01%	
D04	24.000 Q	
DPT. 04	*133.75	
	100.00%	
GROUP04	24.000 Q	
	*133.75	
	4.02%	
*DEPT TL	960.000 Q	
	*3324.84	
	100.00%	

D10	15.000 Q
DPT. 10	-55.72
DEPT (-)	15.000 Q
	-55.72
D11	77.000 Q
DPT. 11	*181.26
*HASH TL	77.000 Q
	*181.26
D12	2.000 Q
DPT. 12	-27.00
HASH (-)	2.000 Q
	-27.00
D13	40.000 Q
DPT. 13	*14.75
*BTTL TL	40.000 Q
	*14.75
D14	18.000 Q
DPT. 14	-6.90
BTTL (-)	18.000 Q
	-6.90

■ Individual group reading

29/08/98 20:27	11	
123456 #1409	MAYER	
11 NILS		
#112 *X1*		
* GROUP *		
D01	600.000 Q	
DPT.01	*1254.42	
D05	30.000 Q	
DPT.05	*43.20	
D06	34.000 Q	
DPT.06	*219.19	
D07	46.000 Q	
DPT.07	*313.25	
D08	37.000 Q	
DPT.08	*259.07	
D09	27.000 Q	
DPT.09	*145.02	
GROUP01	774.000 Q	} Group 1 sales q'ty and total
	*2234.15	

■ Full group reading

29/08/98 20:28	11	
123456 #1410	MAYER	
11 NILS		
#113 *X1*		
* GROUP *		
GROUP01	774.000 Q	} Group 1 sales q'ty and total
	*2234.15	
	67.20%	
GROUP02	123.000 Q	
	*724.02	
	21.78%	
GROUP03	39.000 Q	
	*232.92	
	7.01%	
*DEPT TL	960.000 Q	
	*3324.84	
	100.00%	
DEPT (-)	15.000 Q	
	-55.72	
*HASH TL	77.000 Q	
	*181.26	
HASH (-)	2.000 Q	
	-27.00	
*BTTL TL	40.000 Q	
	*14.75	
BTTL (-)	18.000 Q	
	-6.90	

■ Reading and resetting of sales information for a range of PLUs/subdepartments

This function provides you with X and Z reports for sales information of a certain range of PLUs/subdepartments. You must enter the start and end PLU/subdepartment code of the range. Of course, the range may represent all of the PLUs/subdepartments in your register.

• Sample X report

29/08/98 20:29		11
123456 #1411		MAYER
11 NILS		
#120 *X1*		
* PLU *		
	000001-999999	Range
PLU code	P000001	18.000 Q
Item label	PL000001	*22.50
	P000002	20.000 Q
	PL000002	*44.50
	P000003	6.000 Q
	PL000003	*111.90
	P000004	3.000 Q
	PL000004	*10.50
	P000005	1.000 Q
	PL000005	*5.00
	P000006	9.063 Q
	PL000006	*33.68
	P000008	6.750 Q
	PL000008	*21.75
	P000010	16.000 Q
	PL000010	*107.25
	P000011	7.000 Q
	PL000011	*50.00
	P000013	10.000 Q
	PL000013	*21.00
		} Sales qty and total
	P000060	10.000 Q
	PL000060	*26.00
	P000080	10.000 Q
	PL000080	*46.60
	P000090	8.000 Q
	PL000090	*29.01
	***TOTAL	184.313 Q
		*694.87
		} Range sum

• Sample Z report

30/08/98 9:20		11
123456 #1529		MAYER
11 NILS		
#120 *Z1*		
* PLU *		

The subsequent printout occurs in the same format as in the sample X report.

■ Reading of sales information on PLUs/subdepartments associated with an individual department

29/08/98 20:30 11		
123456 #1412 MAYER		
11 NILS		
#121 *X1*		
* PLU *		
DPT. 01	DO1	Associated dept. code
P000003	6.000 Q	Sales q'ty and total
PL000003	*111.90	
P000004	3.000 Q	
PL000004	*10.50	
P000005	1.000 Q	
PL000005	*5.00	
P000006	9.063 Q	
PL000006	*33.68	

P000080	10.000 Q
PL000080	*46.60
P000090	8.000 Q
PL000090	*29.01
***TOTAL	124.313 Q
	*538.87

■ Reading of sales information for the price amount range of PLUs/subdepartments

29/08/98 20:31 11		
123456 #1413 MAYER		
11 NILS		
#129 *X1*		
CATEGORY		
0.00 -	9999.99	Price amount range
P000001	18.000 Q	Sales q'ty and total
PL000001	*22.50	
P000002	20.000 Q	
PL000002	*44.50	
P000003	6.000 Q	
PL000003	*111.90	
P000004	3.000 Q	
PL000004	*10.50	
P000005	1.000 Q	
PL000005	*5.00	

P000080	10.000 Q
PL000080	*46.60
P000090	8.000 Q
PL000090	*29.01

■ Reading of sales information on PLUs/subdepartments whose sales amounts are zeros

29/08/98 20:31 11		
123456 #1414 MAYER		
11 NILS		
#127 *X1*		
ZERO SAL		
P000007		PLU code
PL000007		Item label
P000009		
PL000009		
P000012		
PL000012		
P000014		
PL000014		
P000015		
PL000015		

■ Reading of commission sales information

29/08/98 20:32 11		
123456 #1415 MAYER		
11 NILS		
#132 *X1*		
* SALES *		
COM. SAL1	*939.19	Commission sales 1 amount total
COM. SAL2	*43.20	
COM. SAL3	*100.02	
COM. SAL4	*127.65	
COM. SAL5	*207.49	
COM. SAL6	*68.74	
COM. SAL7	*167.37	
COM. SAL8	*34.35	
COM. SAL9	*47.99	
NON COM.	*1695.23	Non-commission sales amount
NET 1	*3267.13	

Transaction reading

```

29/08/98 20:33    11
123456 #1416    MAYER
11 NILS

#130 *X1*
* TRANS. *
    
```

In this report the same transaction data as those printed when full reading is taken are printed except department sales totals.

Total in drawer reading

29/08/98 20:40	11	
123456 #1433	MAYER	
11 NILS		
#131 *X1*		
* TL-ID *		
EXCH1	3 Q	Exchange 1 counter
	170.00	Currency exchange 1 total
DOM. CUR1	*280.12	Domestic currency for currency exchange 1 total
EXCH2	5 Q	
	240.00	
DOM. CUR2	*523.76	
EXCH3	1 Q	
	20.00	
DOM. CUR3	*32.96	
EXCH4	3 Q	
	300.00	
DOM. CUR4	*494.19	
***CID	*1912.27	Cash in drawer
*CH ID	*314.65	Cheque in drawer
CA/CH ID	*2226.92	Cash/Cheque in drawer

Reading and resetting of a stacked report

You can print multiple X1/Z1 reports in sequence at a time.

In this case, you need to program in advance what X1/Z1 reports should be printed in the stacked report sequence.

Note

The following job code numbers alone can be used for stacked report printing.

Job code number: 100, 110, 113, 120, 127, 129, 130, 131, 132, 140, 150, 160

Refer to "Selection of X1/Z1 and X2/Z2 reports to be printed in the stacked report sequence" for details.

4 Periodic consolidation

Your register allows you to take consolidation X and Z reports of a chosen period (normally one week or a month).

■ Generality

The periodic reading or resetting reports are the same in format as those in the X1/Z1 report for daily total except job code no. (#2xx) and mode indication ("X2" or "Z2".)

• Sample X report

```
30/08/98 9:21      11
123456 #1530      MAYER
11 NILS
#200 *X2*          Read symbol
```

• Sample Z report

```
30/08/98 9:22      11
123456 #1531      MAYER
11 NILS
#200 *Z2*          Reset symbol
                    Z1 0003  Reset counter
                    Z2 0001  of daily total
GT1 *00000007832.46  Reset counter
GT2 *000000061915.39  of periodic
GT3 -000000054082.93  consolidation
TR  *00000000167.29  Grand total
```

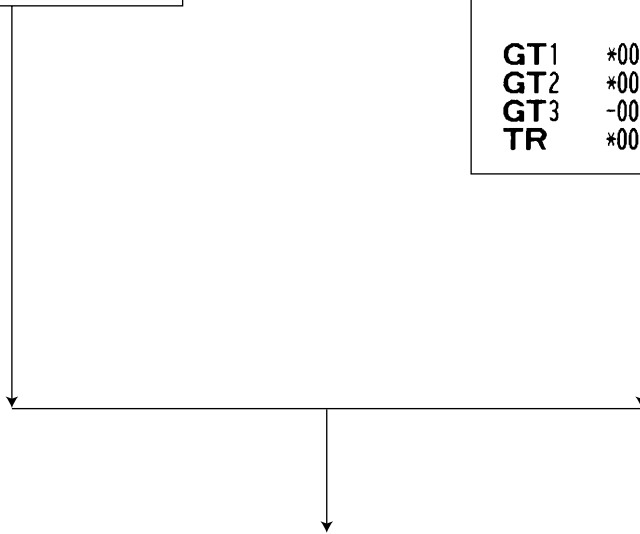

The subsequent printouts are the same in format as those in the X/Z report for daily total.

■ Reading and resetting of the daily net totals

• Sample X report

31/08/98 18:50	11
123456 #1186	MAYER
11 NILS	
#270 *X2*	
* DAILY *	
01/08	56 Q
	*5962.50
02/08	67 Q
	*7111.25
03/08	51 Q
	*6895.00
04/08	63 Q
	*6438.50
05/08	50 Q
	*4675.00
30/08	72 Q
	*6982.50
31/08	53 Q
	*5565.00
***TOTAL	
	1415 Q
	*143639.75

• Sample Z report

01/09/98 16:58	11
123456 #1246	MAYER
11 NILS	
#270 *Z2*	

↓
The subsequent printout occurs in the same format as in the sample X report.

■ Reading and resetting of a stacked report

You can print multiple X1/Z1 reports in sequence at a time.

In this case, you need to program in advance what X1/Z1 reports should be printed in the stacked report sequence.

Note

The following job code numbers alone can be used for stacked report printing.

Job code number: 200, 210, 213, 220, 227, 229, 230, 231, 232, 240, 250, 270

Refer to "Selection of X1/Z1 and X2/Z2 reports to be printed in the stacked report sequence" for details.

COMPULSORY CASH/CHEQUE DECLARATION

If you want to make mandatory the declaration of the cash and cheque amount in the drawer before outputting cashier Z reports, consult your dealer and have your register programmed for compulsory cash/cheque declaration.

If your register is programmed for compulsory cash/cheque declaration (CCD), a cashier must first count and declare the cash and cheque amounts (of domestic and foreign currency) in the drawer, before he or she can output a cashier report. The procedure for outputting a CCD report is shown below.

Types of compulsory cash/cheque declaration

- Compulsory declaration prior to individual cashier resetting
- Compulsory declaration prior to full cashier resetting

Note

- Compulsory cash/cheque declaration is available in the above two types. You can choose either of these. Consult your dealer for details.
- When cash/cheque declaration is compulsory, flash reports are not available.

Key operation

After the first **TL** key is pressed, the register prompts the cashier to input the cash and cheque accounts for both domestic and foreign currency. The cashier can simply input the total amounts of each currency unit, or the number of bills or coins of each denomination of each currency unit.

Individual cashier report

OP X/Z mode



X1/Z1 mode



Full cashier report

X1/Z1 mode



The drawer opens and the cashier is prompted to enter the cash and cheque amounts. ("⌈" is displayed.)

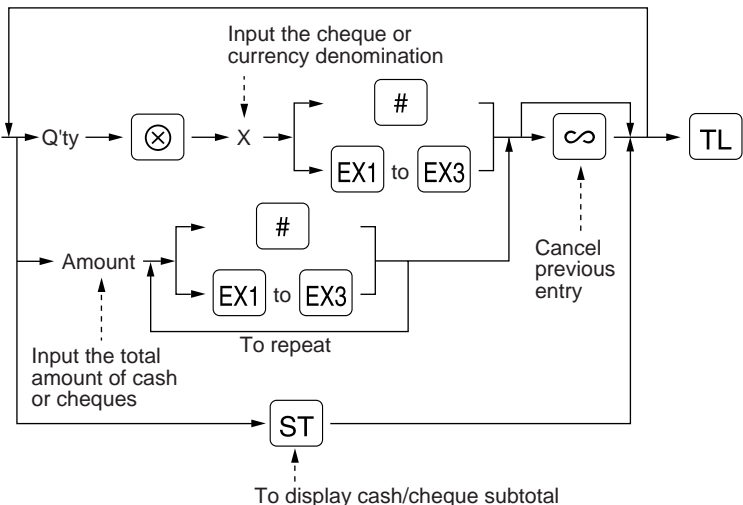

:When inputting the cash or cheque amount in the drawer

EX1 to EX3 :When inputting the amount of a foreign currency in the drawer

01/09/98 12:01 11
 123456 #0063 MAYER
 11 NILS

#151 *Z1*
 * CCD *

CA/CH IS *798.15
 EXCH1 IS 210.00
 EXCH2 IS 30.00
 EXCH3 IS 60.00

CCD entry amount

*CASHIER *

01CSR#1 1 MAYER
 ORDER TL *1357.50
 PAID TL *1357.50
 AVE. *25.14
 5 2 Q
 *2501.09

5 MODE 2 Q
 *4.18

MGR 5 2 Q
 *2.18

SBTL 5 1 Q
 *275.00

GUEST 54 Q

***RA 1 Q
 *58.00

***PO 1 Q
 *45.00

CA/CHK 1 Q
 *20.00

CASH 43 Q
 *768.50

CHECK 3 Q
 *89.00

CREDIT1 2 Q
 *78.00

EXCH1 4 Q
 210.00

EXCH1 IS 210.00

CCD DIF. 0.00

DOM. CUR1 *346.04

EXCH2 1 Q
 30.00

EXCH2 IS 30.00

CCD DIF. 0.00

DOM. CUR2 *49.43

EXCH3 1 Q
 60.00

EXCH3 IS 60.00

CCD DIF. 0.00

DOM. CUR3 *98.88

****CID *631.15

*CH ID *167.00

CA/CH ID *798.15

CA/CH IS *798.15

CCD DIF. *0.00

DIF. TL *0.00

Currency exchange 1
 in drawer to be obtained
 Total of entered (declared)
 exchange 1 in drawer
 Difference

Cash in drawer
 to be obtained
 Check in drawer
 Cash/cheque
 in drawer to be obtained
 Total of entered (declared)
 cash/cheque in drawer
 Difference
 Total of difference

OVERRIDE ENTRIES

Programmed limit for functions (such as for maximum amounts) can be overridden by making an entry in the MGR mode.

Procedure

1. Turn the mode switch to the MGR position.
2. Make an override entry.

Example

On this example, the register has been programmed not to allow deduction entries over 2.00.

Key operation

REG-mode entries 1500
 250 ...Error

Turn the mode switch
to the MGR position.

250

Return the mode switch
to the REG position.

Print

DPT. 02	*15.00
(-) 1	-2.50
CASH	*12.50

CORRECTION AFTER FINALIZING A TRANSACTION (AFTER GENERATING A RECEIPT)

When you need to void incorrect entries that cashiers cannot correct (incorrect entries that are found after finalizing a transaction or cannot be corrected by direct or indirect void), follow this procedure in the MGR mode.

1. Turn the mode switch to the MGR position.
2. Press the  key to put your register in the VOID mode.
3. Repeat the entries that are recorded on an incorrect receipt. (All data for the incorrect receipt are removed from register memory; the voided amounts are added to the void register totalizer.)

Incorrect receipt

28/08/98 14:24	11
123456 #1155	MAYER
11 NILS	
DPT. 02	*10.00
DPT. 03	*1.50
CASH	*11.50



Cancellation receipt

28/08/98 14:26	11
123456 #1156	MAYER
11 NILS	
*  MODE*	
DPT. 02	*10.00
DPT. 03	*1.50
CASH	*11.50

Note

Your machine leaves the VOID mode whenever a transaction is cancelled (i.e. finalized in the VOID mode.) To void additional transactions repeat steps 2. and 3. above.

PRIOR TO ENTRIES

1 Preparations for entries

Before registrations, insert the operator key into the mode switch and turn it to the REG position and check the following items:

■ Receipt and journal paper rolls

If the receipt and journal paper rolls are not set in the machine or there are low rolls, install new ones according to section "4. Installing and removing the paper rolls" under "OPERATOR MAINTENANCE."

■ Receipt ON/OFF function

You can disable receipt printing in the REG mode to save paper using the receipt function. To disable receipt printing, press the **RCPT** key in the OP X/Z position. This key toggles the receipt printing status ON and OFF. To check the receipt printing status, turn the mode switch to the OP X/Z position or press the **CL** key in the REG mode. When the function is in the OFF status, the receipt off indicator "_" illuminates.

Note Your register will print reports regardless of the receipt state. This means that the receipt roll must be installed even when the receipt state is "OFF".

■ Cashier and clerk assignment

Prior to any item entries, cashiers must enter their cashier codes into the register, and may also be required to enter a clerk code. However, these code entries may not be necessary when the same cashier or clerk code is used in the next transaction.

Cashier codes and clerk codes are available in two variants: Variant 1, in which they are displayed ("-00-" to "-99-"), and Variant 2, in which they are not displayed (always "-00-").

When the cashier or clerk code is assigned by the following procedure, the register prints the two-digit cashier code or clerk code (variant 2: "★★") and the cashier or clerk name both on the receipt and journal for every transaction.

Note All of these settings depend on how the register has been programmed. For the selection of these settings, consult your local dealer.

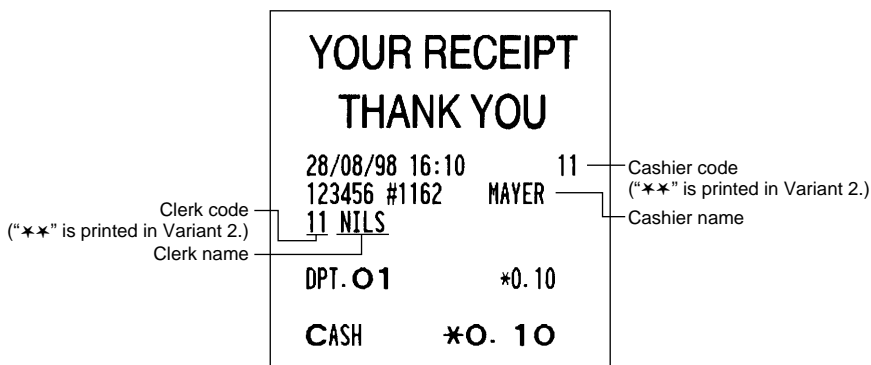

Procedure

Cashier assignment

■ Sign-on

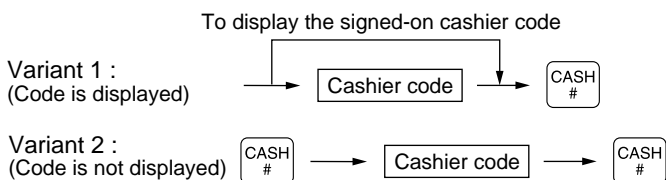

■ Sign-off

Variant 1 / Variant 2 :

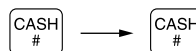

Note

The real cashier key system is also available. In this system put one of the 1 through 15 keys in the cashier switch to sign on. If you want to choose this system, consult your dealer.

Clerk assignment

■ Sign-on

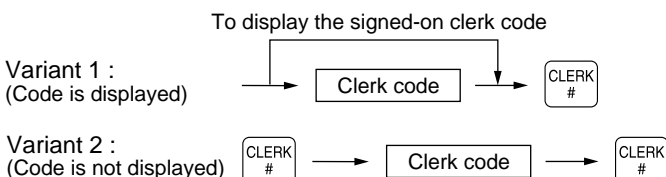

■ Sign-off

Variant 1 / Variant 2 :

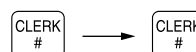

Note

- On the current factory setting, only the entry of the cashier code is required. When cashier & clerk codes entries are desirable for your register, consult your dealer.
- If you want to enter cashier and/or clerk codes before every transaction, consult your dealer.
- For the display type selection of cashier code and clerk code, "Variant 1" has been preset. For the selection of "Variant 2," consult your dealer.
- Clerk can be changed during the transaction. Consult your dealer.

2 Error warning

In the following examples, your register will go into an error state accompanied with a warning beep and the error symbol "E" on the display. Clear the error state by pressing the **CL** key and take proper action. Please refer to the error code table on page 123.

- When you enter an over 32-digit number (entry limit overflow): Cancel the entry and re-enter a correct number.
- When you make an error in key operation: Clear the error and continue operation.
- When you make an entry beyond a programmed amount entry limit: Check to see if the entered amount is correct. If it is correct, it can be rung up in the MGR mode. Contact your manager.
- When an including-tax subtotal exceeds eight digits: Delete the subtotal by pressing the **CL** key and press the **TL**, **CA2**, **CH1** through **CH4**, or **CR1** through **CR4** key to finalize the transaction.

ENTRIES

1 Item entries

Single item entries

Procedure

Department entries

Enter a unit price and press a department key. If you use a programmed unit price, press a department key only.

When using a programmed unit price

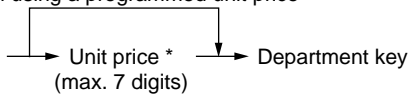

*Less than the programmed upper limit amounts

Note When those departments for which the unit price has been programmed as zero (0) are entered, only the sales quantity is added.

PLU entries (indirect PLU entries)

Enter a PLU code and press the **PLU/SUB** key.

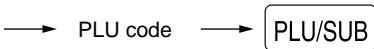

Note When those PLUs for which the unit price has been programmed as zero (0) are entered, only the sales quantity is added.

Subdepartment (open PLU) entries

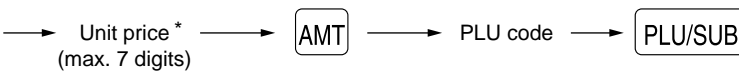

*Less than the programmed upper limit amounts

PLU entries (direct PLU entries)

When using a programmed price

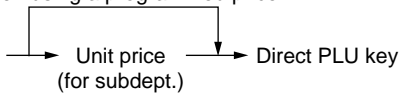

Example

Key operation

```

    1200 [3]
           [5]
    2 [PLU/SUB]
    1200 [AMT] 11 [PLU/SUB]
                [8]
                [TL]
  
```

Print

DPT. 03	*12.00
DPT. 05	*5.00
PL000002	*1.50
PL000011	*12.00
PL000008	*3.50
CASH	*34.00

Repeat entries

You can use this function for entering a sale of two or more same items.

Example

	Key operation	Print
Repeated department entry	200 <input type="text" value="8"/>	<pre> DPT. 08 *2.00 DPT. 08 *2.00 DPT. 08 *2.00 PL000010 *7.15 PL000010 *7.15 PL000010 *7.15 PL000051 *2.85 PL000051 *2.85 PL000060 *5.00 PL000060 *5.00 CASH *43.15 </pre>
	<input type="text" value="8"/>	
	<input type="text" value="8"/>	
Repeated PLU entry (indirect)	10 <input type="text" value="PLU/SUB"/>	
	<input type="text" value="PLU/SUB"/>	
	<input type="text" value="PLU/SUB"/>	
Repeated PLU entry (direct)	<input type="text" value="51"/>	
	<input type="text" value="51"/>	
Repeated subdepartment entry	500 <input type="text" value="AMT"/>	
	60 <input type="text" value="PLU/SUB"/>	
	<input type="text" value="PLU/SUB"/>	
	<input type="text" value="TL"/>	

Multiplication entries

Use this feature entry method when you need to enter two or more same items.

This feature helps when you sell a large quantity of items or need to enter quantities that contain decimals.

Procedure

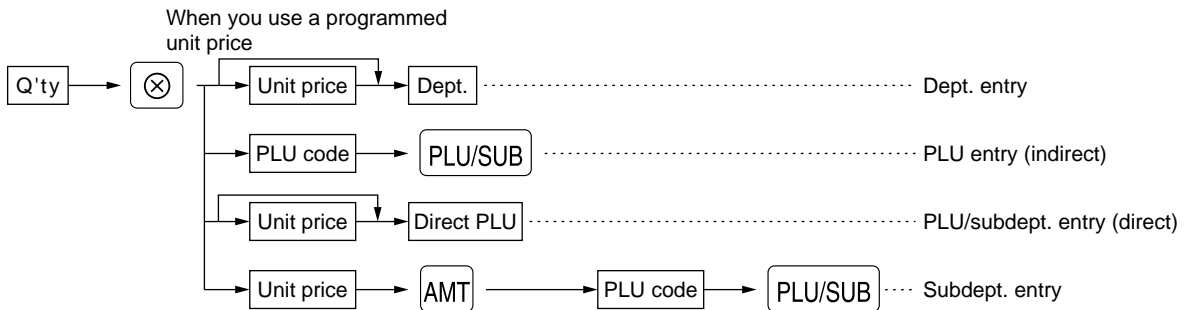

- Q'ty: Up to four digits integer + three digits decimal
- Unit price: Less than a programmed upper limit
- Q'ty x unit price: Up to seven digits

Example

	Key operation	Print
Department entry	7 . 5 <input type="text" value="x"/>	<pre> 7.5x 1.65 DPT. 08 *12.38 15x 2.10 PL000013 *31.50 8.25x 3.00 PL000058 *24.75 3x 1.00 PL000060 *3.00 CASH *71.63 </pre>
	165 <input type="text" value="8"/>	
PLU entry	15 <input type="text" value="x"/>	
	13 <input type="text" value="PLU/SUB"/>	
Direct PLU entry	8 . 25 <input type="text" value="x"/>	
	<input type="text" value="58"/>	
	3 <input type="text" value="x"/>	
Subdepartment entry	100 <input type="text" value="AMT"/>	
	60 <input type="text" value="PLU/SUB"/>	
	<input type="text" value="TL"/>	

■ Successive multiplication entries

This function is practical for example when you enter a sale of items sold by area (square meter).

Procedure

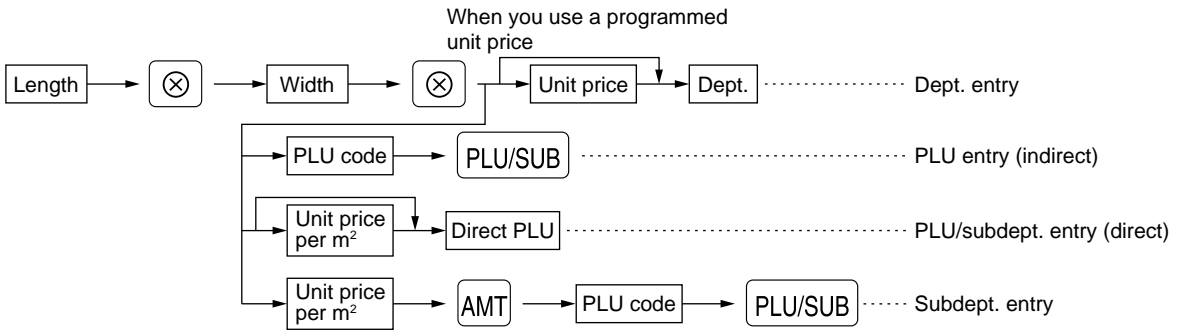

- Length or width: up to seven digits (4-digit integer + 3-digit decimal)
- Unit price: less than a programmed upper limit
- Length x Width x Unit price: up to seven digits (4-digit integer + 3-digit decimal)

Note For actual use of this function, consult your dealer.

Example

	Key operation	Print
Department entry	3	<pre> 3x 4x 4.00 DPT. 05 *48.00 1.5x 2.5x 3.00 PL000008 *11.25 1.75x 1.75x 6.00 PL000006 *18.38 CASH *77.63 </pre>
	4	
	400	
PLU entry	1	<pre> 3x 4x 4.00 DPT. 05 *48.00 1.5x 2.5x 3.00 PL000008 *11.25 1.75x 1.75x 6.00 PL000006 *18.38 CASH *77.63 </pre>
	2	
	8	
Subdepartment entry	1	<pre> 3x 4x 4.00 DPT. 05 *48.00 1.5x 2.5x 3.00 PL000008 *11.25 1.75x 1.75x 6.00 PL000006 *18.38 CASH *77.63 </pre>
	1	
	600	
	6	
	TL	

Split-pricing entries

You will use this function when your customer wants to purchase items normally sold in bulk.

Procedure

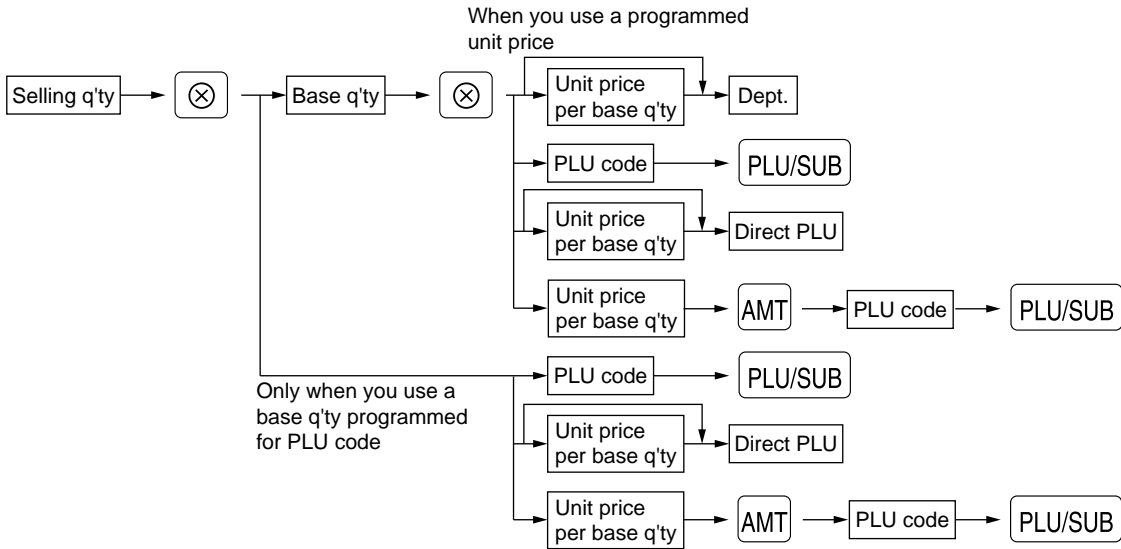

- Selling quantity: Up to four digits integer + three digits decimal
- Base quantity: Up to two digits (integer)

Note For actual use of this function, consult your dealer.

Example

	Key operation	Print
Department entry	7 ⊗	7x 10/ 6.00 DPT. 07 *4.20
	10 ⊗	
	600 7	
PLU entry	8 ⊗	8x 5/ 3.00 PL000035 *4.80
	5 ⊗	
	35 PLU/SUB	
	TL	CASH *9.00

■ Single item cash sale (SICS)/single item finalize (SIF) entries

SICS entries

- This function is useful when a sale is for only one item and is for cash; such as a pack of cigarettes. This function is applicable only to those departments that have been set for SICS or to their associated PLUs or subdepartments.
- The transaction is finalized and the drawer opens as soon as you press the department key, PLU/SUB key or the direct PLU key.

Example	Key operation	Print				
	250 For finishing → 9 the transaction	<table style="width: 100%; border-collapse: collapse;"> <tr> <td style="width: 60%;">DPT. 09</td> <td style="text-align: right;">*2.50</td> </tr> <tr> <td>CASH</td> <td style="text-align: right;">*2.50</td> </tr> </table>	DPT. 09	*2.50	CASH	*2.50
DPT. 09	*2.50					
CASH	*2.50					

Note If an entry to a department or PLU/subdepartment set for SICS follows the ones to departments or PLUs/subdepartments not set for SICS, it does not finalize and results in a normal sale.

SIF entries

- If an entry to a department or PLU/subdepartment set for SIF follows the ones to departments or PLUs/subdepartments not set for SIF, the transaction is finalized immediately as a cash sale.
- Like the SICS function, this function is available for single-item cash settlement.

Example	Key operation	Print						
	1745 8 1500 For finishing → 9 the transaction	<table style="width: 100%; border-collapse: collapse;"> <tr> <td style="width: 60%;">DPT. 08</td> <td style="text-align: right;">*17.45</td> </tr> <tr> <td>DPT. 09</td> <td style="text-align: right;">*15.00</td> </tr> <tr> <td>CASH</td> <td style="text-align: right;">*32.45</td> </tr> </table>	DPT. 08	*17.45	DPT. 09	*15.00	CASH	*32.45
DPT. 08	*17.45							
DPT. 09	*15.00							
CASH	*32.45							

■ Link PLU entries

Operation is the same as normal PLU's. The print of a link PLU entry on the receipt varies according to the PGM2 programming (#2616).

Printing detailed information

When a link PLU is entered, the linked PLUs' total amount and text and their individual amounts are printed automatically.

Example	Key operation	Print												
	21 PLU/SUB TL	<table style="width: 100%; border-collapse: collapse;"> <tr> <td style="width: 60%;">PL000021</td> <td style="text-align: right;">*3.50</td> <td rowspan="4" style="border: none; padding-left: 10px; vertical-align: middle;">} Linked PLUs</td> </tr> <tr> <td>PL000025</td> <td style="text-align: right;">*3.00</td> </tr> <tr> <td>PL000026</td> <td style="text-align: right;">*2.00</td> </tr> <tr> <td>PL000027</td> <td style="text-align: right;">*8.00</td> </tr> <tr> <td>CASH</td> <td style="text-align: right;">*16.50</td> <td></td> </tr> </table>	PL000021	*3.50	} Linked PLUs	PL000025	*3.00	PL000026	*2.00	PL000027	*8.00	CASH	*16.50	
PL000021	*3.50	} Linked PLUs												
PL000025	*3.00													
PL000026	*2.00													
PL000027	*8.00													
CASH	*16.50													

Printing leading link PLUs and total sales amount

When a link PLU is entered, only the leading link PLU's text and the total sales amount (the sum of prices for PLU's which are included in the link PLU) are printed.

Example	Key operation	Print						
	21 PLU/SUB TL	<table border="0"><tr><td>PL000021</td><td style="text-align: right;">*16.50</td><td style="border-left: 1px solid black; padding-left: 5px;">Total amount</td></tr><tr><td>CASH</td><td style="text-align: right;">*16.50</td><td></td></tr></table>	PL000021	*16.50	Total amount	CASH	*16.50	
PL000021	*16.50	Total amount						
CASH	*16.50							

Note If a discount entry is made for a link PLU, the discount amount is calculated based on the total sales amount. The discount itself is given to the leading link PLU.

2 Displaying subtotals

Your machine provides the following two types of subtotals:

■ Normal subtotal

This is a subtotal which is displayed by pressing the ST key. When you press it, the subtotal of all entries which have been made is displayed and the symbol "□" will light up in the display.

Example	Key operation	Print								
	100 9 100 2 700 3 ST TL	<table border="0"><tr><td>DPT.09</td><td style="text-align: right;">*1.00</td></tr><tr><td>DPT.02</td><td style="text-align: right;">*1.00</td></tr><tr><td>DPT.03</td><td style="text-align: right;">*7.00</td></tr><tr><td>CASH</td><td style="text-align: right;">*9.00</td></tr></table>	DPT.09	*1.00	DPT.02	*1.00	DPT.03	*7.00	CASH	*9.00
DPT.09	*1.00									
DPT.02	*1.00									
DPT.03	*7.00									
CASH	*9.00									

Note Subtotal will not be printed on a receipt on the current factory setting. If you want to print it, consult your dealer.

■ Difference subtotal (Differ ST)

This is a subtotal which is printed by pressing the DIFFER ST key. You can get two or more difference subtotals in one transaction.

When you press it first, the difference subtotal of all entries which have been made is displayed and printed. If you press it second, you will get the difference subtotal of entries which have been made after you last got it.

Taxes are calculated each time you press the DIFFER ST key, and taxes and taxable subtotals are printed on the receipt according to the programming (job #2616).

Example	Key operation	Print												
	100 9 200 2 DIFFER ST 700 3 TL	<table border="0"><tr><td>DPT.09</td><td style="text-align: right;">*1.00</td></tr><tr><td>DPT.02</td><td style="text-align: right;">*2.00</td></tr><tr><td>DIFF ST</td><td style="text-align: right;">*3.00</td></tr><tr><td>DPT.03</td><td style="text-align: right;">*7.00</td></tr><tr><td>DIFF ST</td><td style="text-align: right;">*7.00</td></tr><tr><td>CASH</td><td style="text-align: right;">*10.00</td></tr></table>	DPT.09	*1.00	DPT.02	*2.00	DIFF ST	*3.00	DPT.03	*7.00	DIFF ST	*7.00	CASH	*10.00
DPT.09	*1.00													
DPT.02	*2.00													
DIFF ST	*3.00													
DPT.03	*7.00													
DIFF ST	*7.00													
CASH	*10.00													

3 Finalization of transaction

■ Cash or cheque tendering

Press the **[ST]** key to get a subtotal, enter the amount tendered by your customer, then press the **[TL]** or **[CA2]** key if it is a cash tender or press one of the **[CH1]** through **[CH4]** key if it is a cheque tender. When the amount tendered is greater than the amount of the sale, your register will show the change due amount and the symbol "⌈" will light up. Otherwise your register will show a deficit and the symbol "⌋" will light up. Make a correct tender entry.

Example

Cash tendering

Key operation

}
[ST]
 1000 **[TL]**

Print

***TOTAL	*7.35
CASH	*10.00
CHANGE	*2.65

Cheque tendering

Key operation

}
[ST]
 1000 **[CH1]**

Print

***TOTAL	*7.35
CHECK	*10.00
CHANGE	*2.65

■ Mixed tendering (cheque + cash)

Example

Key operation

}
[ST]
 1000 **[CH1]**
 500 **[TL]**

Print

***TOTAL	*14.56
CHECK	*10.00
CASH	*5.00
CHANGE	*0.44

■ Cash or cheque sale that does not need any tender entry

Enter items and press the **[TL]** or **[CA2]** key if it is a cash sale or press one of the **[CH1]** through **[CH4]** if it is a cheque sale. Your register will display the total sale amount.

Example

Key operation

300 **[6]**
 10 **[PLU/SUB]**
[TL]

Print

DPT. 06	*3.00
PL000010	*7.15
CASH	*10.15

In the case of cheque sale

CHECK	*10.15
-------	--------

■ Credit sale

Enter items and press the corresponding credit keys (CR1) through (CR4).

Example	Key operation	Print
	2500 <input type="button" value="6"/> 3250 <input type="button" value="7"/> <input type="button" value="CR1"/>	<div style="border: 1px solid black; padding: 5px;"> DPT. 06 *25. 00 DPT. 07 *32. 50 CREDIT1 *57. 50 </div>

Amount tendering operations (i.e., change calculations) can be achieved by the (CR1) through (CR4) key when a PGM2 programming allows them.

■ Mixed-tender sale (cash or cheque tendering + credit tendering)

Example	Key operation	Print
	} <input type="button" value="ST"/> 950 <input type="button" value="TL"/> <input type="button" value="CR2"/>	<div style="border: 1px solid black; padding: 5px;"> ***TOTAL *49. 50 CASH *9. 50 CREDIT2 *40. 00 </div>

Note Press one of the (CH1) through (CH4) keys or the (CR1) through (CR4) keys in place of the (TL) key when your customer makes payment in cheques or by credit account.

4 Computation of VAT (Value Added Tax)/tax

■ VAT/ tax system

The machine may be programmed for the following six tax systems by your dealer.

Automatic VAT 1-6 system (Automatic operation method using programmed percentages)

This system, at settlement, calculates VAT for taxable 1 through 6 subtotals by using the corresponding programmed percentages.

Automatic tax 1-6 system (Automatic operation method using programmed percentages)

This system, at settlement, calculates taxes for taxable 1 through 6 subtotals by using the corresponding programmed percentages, and also adds the the calculated taxes to those subtotals, respectively.

Manual VAT 1-6 system (Manual entry method using programmed percentages)

Procedure



This system provides the VAT calculation for taxable 1 through 6 subtotals. This calculation is performed using the corresponding programmed percentages when the (VAT) key is pressed just after the (ST) key.

Manual VAT 1 system (Manual entry method for subtotals that uses VAT 1 preset percentages)

Procedure

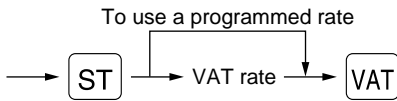

This system enables the VAT calculation for the then subtotal. This calculation is performed using the VAT 1 preset percentages when the **VAT** key is pressed just after the **ST** key. For this system, the keyed-in tax rate can be used.

Manual tax 1-6 system (Manual entry method using preset percentages)

Procedure

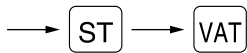

This system provides the tax calculation for taxable 1 through 6 subtotals. This calculation is performed using the corresponding programmed percentages when the **VAT** key is pressed just after the **ST** key. After this calculation, you must finalize the transaction.

Automatic VAT 1-3 and automatic tax 4-6 system

This system enables the calculation in the combination with automatic VAT 1 through 3 and automatic tax 4 through 6. The combination can be any of VAT1 through VAT3 corresponding to taxable 1 through taxable 3 and any of tax 4 through 6 corresponding to taxable 4 through taxable 6 for each item. The tax amount is calculated automatically with the percentages previously programmed for these taxes.

Note

- A PLU not programmed for any of the tax statuses is registered depending on the tax status of the department which the PLU belongs to.
- VAT/tax assignment is printed at the fixed right position near the amount on the receipt as follows:

```

    VAT1/tax1  —————> A
    VAT2/tax2  —————> B
    VAT3/tax3  —————> C
    VAT4/tax4  —————> D
    VAT5/tax5  —————> E
    VAT6/tax6  —————> F
  
```

When the multiple VAT/tax is assigned to a department or a PLU, a smaller number of the VAT/tax will be printed. For details, contact your authorized SHARP dealer.

Example

Key operation

(When the manual VAT 1-6 system is selected)

550 **4**
ST
VAT
TL

Print

DPT. 04	*5.50 A
SUBTOTAL	*5.50
TAX1 ST	*5.50
VAT 1	*0.26
NET 1	*5.24
CASH	*5.50

■ VAT shift entries





This feature is intended to shift the tax status of a particular department (or PLU) programmed for taxable 1 or taxable 1 and taxable 3.

1. When the VAT shift entry is made for a particular department or PLU programmed for taxable 1, their tax status shifts to taxable 2.
2. When this entry is made for a particular department (or PLU) programmed for taxable 1 and taxable 3, the tax status "taxable 1" remains unchanged, but the other "taxable 3" is ignored.

Procedure

Press the  to activate the VAT shift prior to entering department(s) or PLU(s) concerned.

Example

Key operation	Print												
(When the manual VAT 1-6 system is selected.)													
550													
													
													
													
													
													
	<table border="1"> <tbody> <tr> <td>DPT. 04</td> <td>*5.50 B</td> </tr> <tr> <td>SUBTOTAL</td> <td>*5.50</td> </tr> <tr> <td>TAX2 ST</td> <td>*5.50</td> </tr> <tr> <td>VAT 2</td> <td>*0.21</td> </tr> <tr> <td>NET 2</td> <td>*5.29</td> </tr> <tr> <td>CASH</td> <td>*5.50</td> </tr> </tbody> </table>	DPT. 04	*5.50 B	SUBTOTAL	*5.50	TAX2 ST	*5.50	VAT 2	*0.21	NET 2	*5.29	CASH	*5.50
DPT. 04	*5.50 B												
SUBTOTAL	*5.50												
TAX2 ST	*5.50												
VAT 2	*0.21												
NET 2	*5.29												
CASH	*5.50												









5 Auxiliary entries

■ Percent calculations (premium or discount)

- Your register provides the percent calculation for the subtotal or each item entry depending on the programming.
- Percentage: 0.01 to 99.99%

Percent calculation for the subtotal

Example

Key operation	Print																
(When a discount of 10% is programmed for the  key)																	
4																	
																	
140																	
																	
225																	
																	
																	
																	
																	
																	
	<table border="1"> <tbody> <tr> <td>4x 1.40</td> <td></td> </tr> <tr> <td>DPT. 05</td> <td>*5.60</td> </tr> <tr> <td>DPT. 07</td> <td>*2.25</td> </tr> <tr> <td>DPT. 07</td> <td>*2.25</td> </tr> <tr> <td>SUBTOTAL</td> <td>*10.10</td> </tr> <tr> <td></td> <td>-10.00%</td> </tr> <tr> <td>%1</td> <td>-1.01</td> </tr> <tr> <td>CASH</td> <td>*9.09</td> </tr> </tbody> </table>	4x 1.40		DPT. 05	*5.60	DPT. 07	*2.25	DPT. 07	*2.25	SUBTOTAL	*10.10		-10.00%	%1	-1.01	CASH	*9.09
4x 1.40																	
DPT. 05	*5.60																
DPT. 07	*2.25																
DPT. 07	*2.25																
SUBTOTAL	*10.10																
	-10.00%																
%1	-1.01																
CASH	*9.09																

Percent calculation for item entries

Example

Key operation

(When a premium of 15% is programmed for the [%2] key)

800

 90
 7 5

Print

DPT. 06	*8.00
	15.00%
%2	*1.20
PL000090	*5.00
	7.5%
%2	*0.38
CASH	*14.58

■ Deduction entries

Your register allows you to deduct a certain amount less than a programmed upper limit after the entry of an item or the computation of subtotal depending on the programming.

Deduction for the subtotal

Example

Key operation

575
 80

 100

Print

DPT. 06	*5.75
PL000080	*7.50
(-) 2	-1.00
CASH	*12.25

Deduction for item entries

Example

Key operation

675
 75

Print

DPT. 07	*6.75
(-) 1	-0.75
CASH	*6.00

■ Refund entries

If a refund item is the one entered into a department, enter the amount of the refund, then press the **[RF]** key and the corresponding department key in this order; and if an item entered into a PLU is returned, enter the corresponding PLU code, then press the **[RF]** and **[PLU/SUB]** keys, or press the **[RF]** and direct PLU keys without entry of PLU code, in this order.

Example	Key operation	Print
	250 [RF] [6] [7] [⊗] 13 [RF] [PLU/SUB] [TL]	<div style="border: 1px solid black; padding: 5px;"> <p>DPT. 06 R-2.50 -7x 2.10 PL000013 R-14.70 CHANGE *17.20</p> </div>

■ Printing of non-add code numbers

Enter a non-add code number such as a customer's code number and credit card number within a maximum of 16 digits and press the **[#]** key at any point during the entry of a sale. Your register will print it at once.

Example	Key operation	Print
	1230 [#] 1500 [6] [CR1]	<div style="border: 1px solid black; padding: 5px;"> <p>#0000000000001230 DPT. 06 *15.00 CREDIT1 *15.00</p> </div>

6 Payment treatment

■ Currency exchange

Your register allows payment entries of foreign currency. Pressing one of the **[EX1]** through **[EX4]** key creates a subtotal in foreign currency. Cash alone can be handled after currency exchange.

Procedure

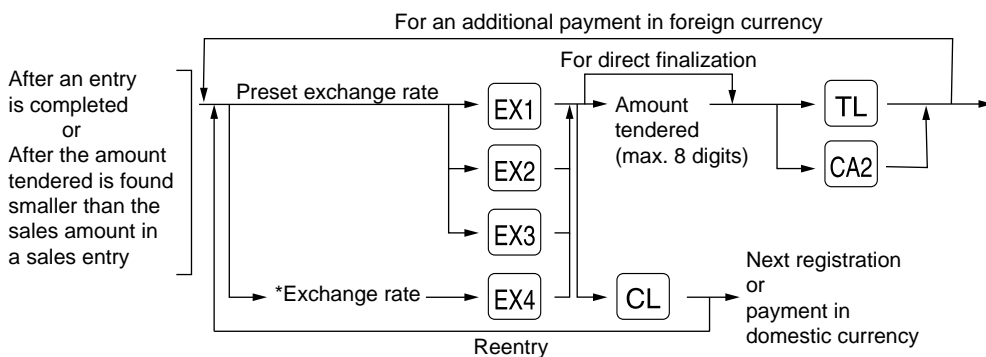

*Exchange rate: 0.000000 to 999.999999

Note When the amount tendered is short, the deficit is shown in domestic currency.

Example

Preset exchange rate (0.6068) - EX1

Key operation

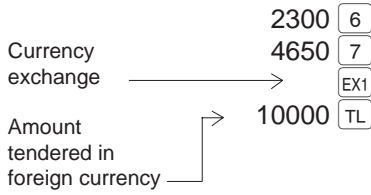

Print

DPT. 06	*23.00	
DPT. 07	*46.50	
***TOTAL	*69.50	Domestic currency
EXCH1	0.606800	Exchange rate
	42.18	Foreign currency
CASH	100.00	
CHANGE	*95.28	Domestic currency

Manual exchange rate - EX4 (The [EX4] key can be used only for the manual entry of an exchange rate.)

Key operation

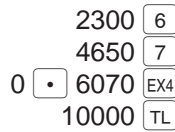

Print

DPT. 06	*23.00
DPT. 07	*46.50
***TOTAL	*69.50
EXCH4	0.6070
	42.19
CASH	100.00
CHANGE	*95.23

Received on account entries

Procedure

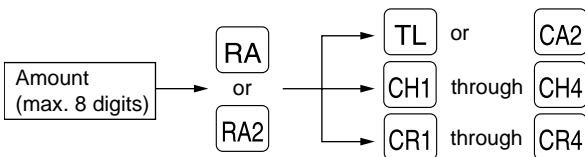

Example

Key operation



Print

#0000000000012345	
CHECK	
***RA	*48.00

Paid out entries

Procedure

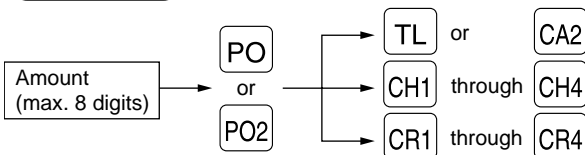

Example**Key operation****Print**

6789 [#]
 3000 [PO]
 [CH1]

```
#0000000000006789
CHECK
***PO          *30.00
```

■ No sale (exchange)

Simply press the [NS] key without any entry. The drawer will open and the printer will print "NO SALE" on both the journal and the receipt. If you let your machine print a non-add code number before pressing the [NS] key, a no sale entry is achieved with a non-add code number printed.

```
#0000000000045678
NO SALE
```

■ Cashing a cheque

Enter the cheque amount, then press one of the [CH1] through [CH4] key.

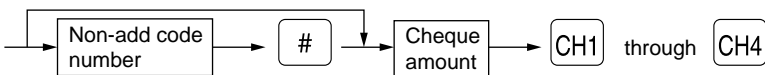
Procedure**Example****Key operation****Print**

6789 [#]
 3000 [CH1]

```
#0000000000006789
CA/CHK          *30.00
```

7 Automatic sequencing key ([AUTO] key) entries

You can achieve a programmed transaction simply by pressing a corresponding automatic sequencing key.

Example

[AUTO 2] = 500 [7] [TL]

Key operation**Print**

[AUTO 2]

```
DPT.07          *5.00
CASH            *5.00
```

CORRECTION

1 Correction of the last entry (direct void)

If you make an incorrect entry relating to a department, PLU/subdepartment, percentage (%1 through %4), deduction (⊖ through ⊖4) or refund, you can void this entry by pressing the ∞ key immediately after the incorrect entry.

Example

Key operation

1250 6
 ∞
 2 PLU/SUB
 ∞
 600 8
 %2
 ∞
 328 9
 28 ⊖
 ∞
 250 RF 6
 ∞
 TL

Print

DPT. 06	*12.50
DPT. 06	∅-12.50
PL000002	*1.50
PL000002	∅-1.50
DPT. 08	*6.00
	15.00%
%2	*0.90
%2	∅-0.90
DPT. 09	*3.28
(-) 1	-0.28
(-) 1	∅*0.28
DPT. 06	R-2.50
DPT. 06	R∅*2.50
CASH	*9.28

2 Correction of the next-to-last or earlier entries (indirect void)

With the ∞ key, you can void any incorrect positive department or PLU/subdepartment entry made during a transaction if you find it before finalizing the transaction (e.g. pressing the TL key). This function is applicable to plus department and PLU/subdepartment entries only.

Example

Key operation

Correction of a department entry → 1310 6
 1755 7
 10 PLU/SUB
 8
 Correction of a PLU entry (direct PLU) → 58 PLU/SUB
 825 7
 Correction of a PLU entry (indirect PLU) → 1310 ∞ 6
 ∞ 8
 58 ∞ PLU/SUB
 TL

Print

DPT. 06	*13.10
DPT. 07	*17.55
PL000010	*7.15
PL000008	*3.00
PL000058	*3.00
DPT. 07	*8.25
DPT. 06	∅-13.10
PL000008	∅-3.00
PL000058	∅-3.00
CASH	*32.95

3 Subtotal void

You can void an entire transaction. Once subtotal void is executed, the transaction is aborted and the register issues a receipt.

Example

Key operation	Print
1310 [2]	DPT. 02 *13.10
1755 [6]	DPT. 06 *17.55
10 [PLU/SUB]	PL000010 *7.15
35 [PLU/SUB]	PL000035 *3.00
Subtotal void {	ST
	[∞]
	ST
	SUBTOTAL *40.80
	SBTL 0 -40.80
	***TOTAL *0.00

4 Correction of incorrect entries not handled by the direct or indirect void function

Any errors found after the entry of a transaction has been completed or during an amount tendered entry cannot be voided. These errors must be corrected by the manager.

The following steps should be taken:

1. If you are making the amount tendered entry, finalize the transaction.
2. Make correct entries from the beginning.
3. Hand the incorrect receipt to your manager for its cancellation.

SPECIAL PRINTING FUNCTIONS

1 Copy receipt printing

If your customer wants a receipt after you have finalized a transaction with the receipt function being in the "OFF" status (no receipting), press the **RCPT** key. This will produce a receipt. Your register can also print a copy receipt when the receipt function is in the "ON" status. If you want to make a copy, please consult your dealer.

Note Pressing the **RCPT** key in the OP X/Z mode before registration toggles the status "ON" and "OFF".

Example Printing a copy receipt after making the entries shown below with the receipt function being in the "OFF" status

Key operation	Print
850 2 3 ⊗ 150 1 TL	<div style="border: 1px solid black; padding: 5px;"> 28/08/98 15:54 11 123456 #1161 MAYER 11 NILS DPT. 02 *8.50 3x 1.50 DPT. 01 *4.50 CASH *13.00 </div>
Print on the journal	
For receipting → RCPT	<div style="border: 1px solid black; padding: 5px;"> 28/08/98 15:54 11 123456 #1161 MAYER 11 NILS DPT. 02 *8.50 3x 1.50 DPT. 01 *4.50 CASH *13.00 </div>
Print on the receipt	

When the receipt function is in the "ON" status and you press the **RCPT** key to make a second copy

28/08/98 15:54 11
 123456 #1161 MAYER
 11 NILS

 COPY
 DPT. **02** *8.50
 3x 1.50
 DPT. **01** *4.50

CASH *13.00

When the receipt function is in the "ON" status, the "*COPY*" symbol will be printed on the receipt.

2 Guest check copy

You can use this function when you want to take a copy of guest check.
Press the  key and make a desired entry.

Procedure

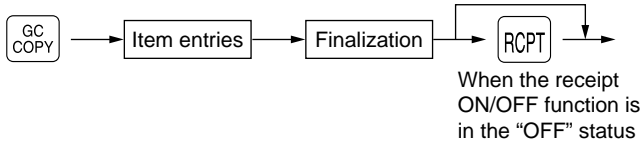

Note The guest check copy has nothing to do with the memory.

Example

Key operation

1480   

Print

```

    *G. C COPY*
    DPT. 02      *14. 80
    CASH        *14. 80
  
```

3 Printing of header and footer graphic logos

As a default setting, it is set to print a graphic logo on the top of each receipt (header graphic logo), and another graphic logo can be printed on the bottom of each receipt (footer graphic logo) with the job code #2616. You can also print the graphic logos with the combination of 3-line header logo message or 3-line footer logo message, or can print only logo message without graphic logo. Consult your dealer when you want to change the setting.

• Sample receipt with a header graphic logo and a footer graphic logo

YOUR RECEIPT

THANK YOU

02/09/98 12:21 11
123456 #0068 MAYER
11 NILS

DPT. 02 *10. 00

CASH *10. 00



} Header graphic logo

} Footer graphic logo

OVERLAPPED CASHIER ENTRY

This function allows you to switch from one cashier to another and to interrupt the first cashier's entry. So the second cashier can do his or her entry in this mode. For actual use of this function, consult your dealer.

Example

Cashier 1: Entry started

Cashier 2: Cashier change (1 to 2), interrupt initiated

Cashier 2: Transaction finished (2)

Cashier 1: Cashier change (2 to 1), entry restart

Note

- When the cashier and clerk system is applied for your register, you cannot operate the overlapped cashier entry.
- The overlapped cashier entry is not effective while the tendering sale is going on.
- If any cashier is still making an entry (or has not finalized the transaction yet), the machine does not run in any mode other than REG and MGR and can print no X/Z reports. The error code "E22" and the corresponding cashier code(s) are displayed at this time.

Key operation		Comments
1. Cashier 1 is assigned.	(1 <small>CASH #</small>) 100 1 360 3 3	The entry by cashier 1 is started.
2. Cashier 2 is assigned.	2 <small>CASH #</small> 3 <small>⊗</small> 150 2 TL	The entry by cashier 2 is started. (The entry by cashier 1 is interrupted.)
3. Cashier 1 is assigned.	1 <small>CASH #</small> 100 1 360 3 TL	The entry by cashier 1 is restarted. The transaction by cashier 1 is finalized.

OPERATOR MAINTENANCE

1 In case of power failure

When power is lost, the machine retains its memory contents and all information on sales entries.

- When power failure is encountered in register idle state or during an entry, the machine returned to the normal state of operation after power recovery.
- When power failure is encountered during a printing cycle, the register prints "======" and then carries out the correct printing procedure after power recovery. (See the sample print.)

28/08/98 16:15	11
123456 #1164	MAYER
11 NILS	
DPT. 07	*10.00
DPT. 08	*35.00
=====	
DPT. 08	*35.00
CASH	*45.00

2 In case of printer error

If the printer runs out of paper, the printer will stall, "PPPPPPPPPP" will appear on the display, and the register will start to continuously produce an intermittent beeping tone. Key entries will not be accepted. Referring to "5. Installing and removing the paper roll" in this chapter, install a new roll paper in the proper position, then press the **CL** key. The printer will print the power failure symbol and resume printing.

If the print head comes up, the printer stalls, "H" will appear on the very left of the display, and the register will start to continuously produce an intermittent beeping tone. Key entries will not be accepted. Bring back the print head to the correct position, then press the **CL** key. The printer will print the power failure symbol and resume printing.

3 Thermal printing

Your register prints by means of thermal printing. The print head applies heat to thermal paper which is chemically treated to change color when heated to a certain level. This creates the printed text.

■ Cautions in handling the printer

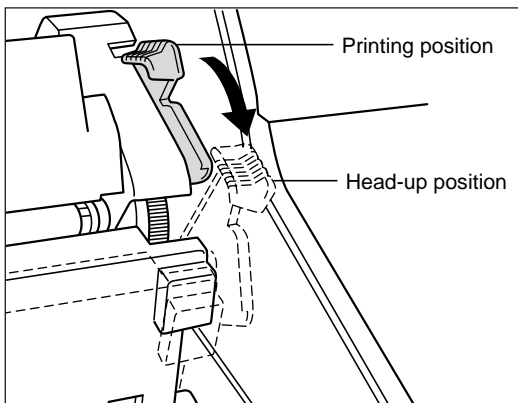

- If you are not going to use the register for an extended period of time, pull the print head release lever toward you so that the print head is set apart from the plate.

- Avoid the following environments:
 - Dusty and humid places
 - Direct sunlight
 - Iron powder (A permanent magnet and electromagnet are used in this machine.)
- Use the print head release lever only when necessary.
- Never pull the paper when it is in contact with the print head. First release the head with the print head release lever, and then remove the paper.
- Never touch the surface of the print head.
- Never touch around the print head and the motor during printing or before they have had sufficient time to cool.

■ Cautions in handling the recording paper (thermal paper)

- Use only the paper specified by SHARP.
- Do not unpack the thermal paper until you are ready to use it.
- Avoid heat. The paper will color at around 70°C.
- Avoid dusty and humid places for storage. Avoid direct sunlight.
- The printed text on the paper can discolor under the following conditions:
 - Exposure to high humidity and temperature
 - Exposure to the direct sunlight
 - Contact with glue, thinner or a freshly copied blueprint.
 - Heat caused by friction from scratching or other such means.
 - Contact with a rubber eraser or adhesive tape.
- Be very careful when handling the thermal paper. If you want to keep a permanent record, copy the printed text with a photocopier.

4 Paper roll near-end sensing function (only for the journal paper) <option>

When the journal paper roll comes near the end or is not loaded, the machine senses this condition and sounds an alarm, displaying the error code "E04". At this time, clear the alarm with the **CL** key and replace the paper roll as soon as possible. The following entry can be made after clearing the alarm. However, since this function works each time one transaction is completed, the alarm sound will be emitted again as the following transaction is completed unless the paper roll is replaced.

- The sensing position depends upon the size of the paper tube.
- Therefore, it is advisable to use paper rolls - whose paper tube is 18 mm in O.D. and 12 mm in I.D. - specified by SHARP.
- If the sensing occurs too early or late, contact your dealer.

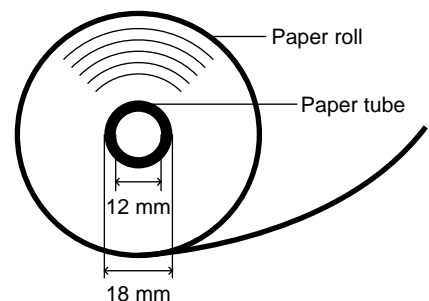

5 Installing and removing the paper roll

■ Recording paper specifications

Be sure to use paper rolls specified by SHARP.

The use of any other paper rolls than specified could cause paper jamming, resulting in register malfunction.

Paper specification

Paper width:	44.5 ± 0.5 mm
Max. outside diameter:	80 mm
Quality:	Thermal paper
Paper tube:	18 mm

- **Be sure to set paper roll(s) prior to using your machine, otherwise it may cause a malfunction.**

Install the paper roll in the printer. Be careful then to set the roll and cut the paper end correctly.

Note *If the top end of the paper roll is fixed with paste or tape, the paper may lose its color development ability in the pasted or taped area due to the deterioration of the heat-sensitive color development component of the paper surface. This may result in nothing appearing at this location when printing is performed. Therefore, when setting a new paper roll in the machine, be sure to cut off approximately one revolution (approx. 25 cm long).*

(How to set the paper roll)

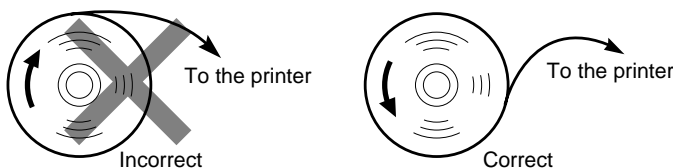

(How to cut the paper end)

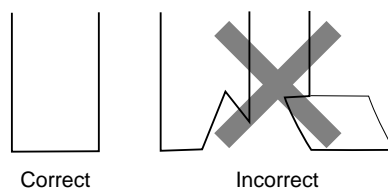

■ Installing the paper roll

Installing the receipt paper roll

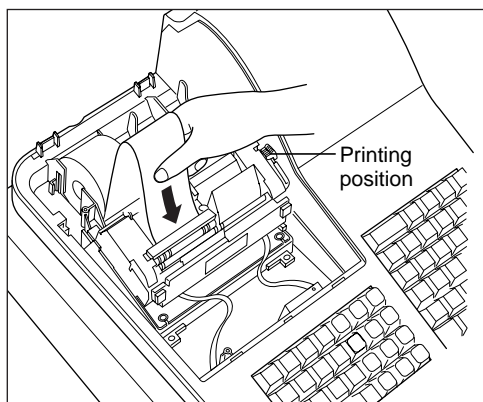

1. Turn the mode switch to the "REG" position with the AC cord connected.
2. Remove the printer cover.
3. Check that the print head release lever is in its printing position.
4. Set the paper correctly as illustrated above in the receipt side of the printer.
5. Insert the end of the paper into the paper chute as shown on the left. It will automatically be fed through the printer.
6. Cut off the excess paper that comes out of the printer with the manual cutter.
7. Replace the printer cover.

Installing the journal paper roll

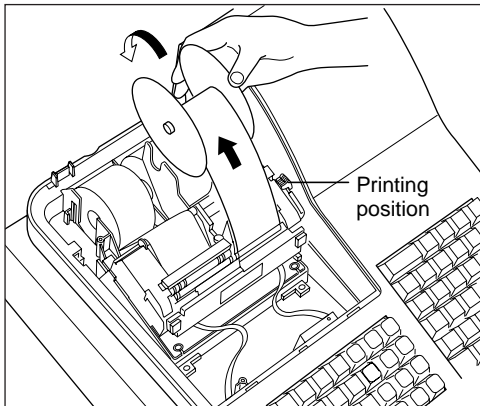



1. Turn the mode switch to the "REG" position with the AC cord connected.
2. Remove the printer cover.
3. Check that the print head release lever is in its printing position.
4. Set the paper correctly as illustrated on the previous page in the journal side of the printer.
5. Insert the end of the paper into the paper chute as shown on the left. It will automatically be fed through the printer.
6. Insert the end of the paper into the slit in the paper take-up spool. (Press the  key to feed more paper through if required.)
7. Wind the paper two or three turns around the spool shaft.
8. Set the spool on the bearing.
9. Replace the printer cover.

Note

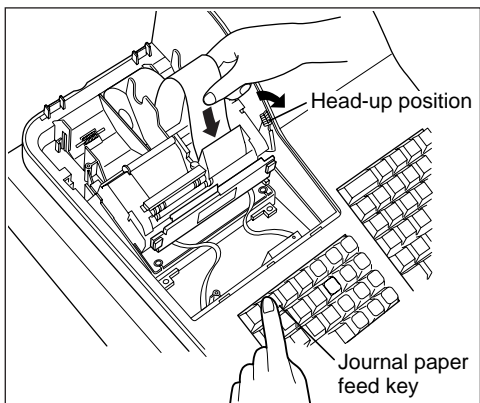
- When it is difficult to insert paper into the paper chute, try inserting it again by following the steps described below.



In case of inserting the journal paper roll

1. Cut off the end of paper in a single straight cut.
2. Pull the print head release lever toward you to lift up the print head.
3. Insert the end of paper into the paper chute, while pressing the corresponding paper feed key ( key or  key).
4. When the end of paper comes out of the printer, release the feed key and return the print head release lever to its original position.
5. Press the feed key to feed more paper.

- When you want to manually install a new roll of paper while your machine is turned off, follow the steps shown below:

1. Pull the print head release lever toward you to lift up the print head.
2. Correctly place the new paper roll into the receipt/journal paper roll location.
3. Insert the paper end into the paper chute until it comes out of the printer.
4. Cut or roll the paper onto the take-up spool as described for automatic installation.
5. Return the print head release lever to its original position.

■ Removing the paper roll

When a red dye appears on the paper roll, it is time to replace the existing paper roll. Replace the paper roll with a new one. If you plan not to use your register for an extended period of time, remove the paper roll, and store it in the appropriate place.

Removing the receipt paper roll

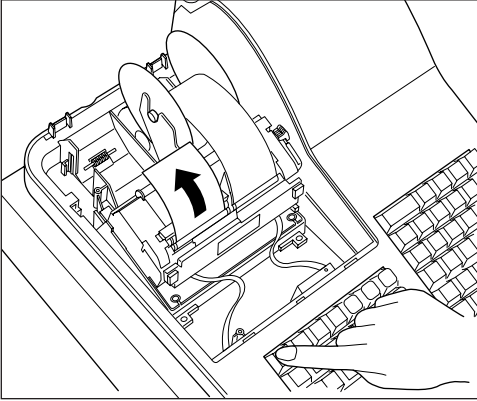



1. Remove the printer cover.
2. Cut the paper behind the printer and near the paper roll.
3. Press the  key until the paper remaining in the printer comes out completely.
4. Remove the paper roll from the back of the printer.

Note

Do not pull the paper through the printer.

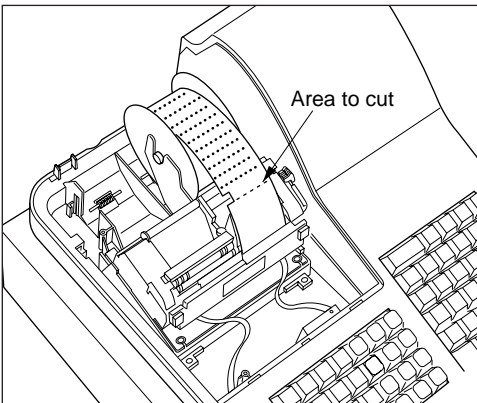
Removing the journal paper roll



1. Remove the printer cover.
2. Press the  key to advance the journal paper until its printed part is out of the way.
3. Cut the paper and remove the take-up spool.

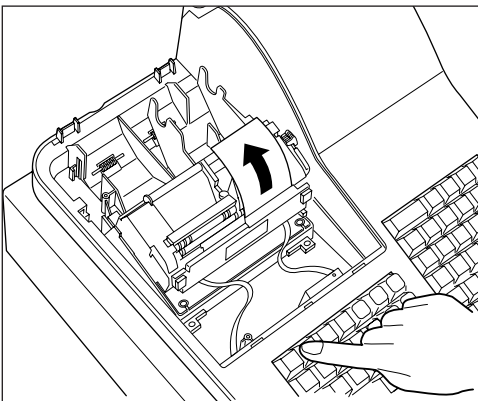

4. Cut the paper behind the printer and near the paper roll.
5. Press the  key until the paper remaining in the printer comes out completely.
6. Remove the paper roll from the back of the printer.

Note

Do not pull the paper through the printer.

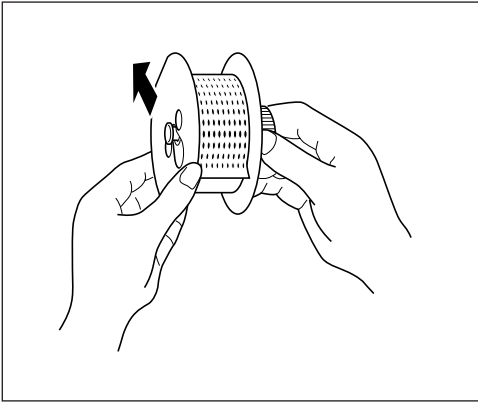

7. Remove the outer side of the take-up spool as shown on the left.

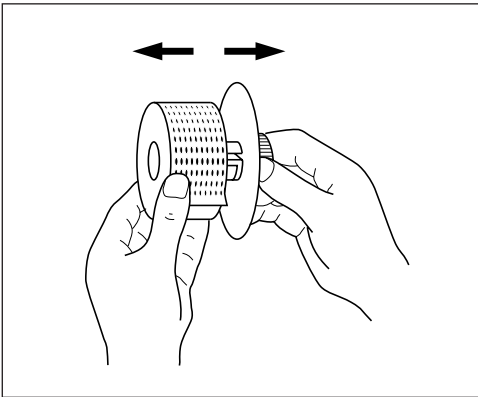

8. Remove the printed journal roll from the take-up spool.

■ Removing a paper jam

Precaution: Be very careful with the manual cutter, so as not to cut yourself. Never touch the print head immediately after printing, because the head may still be hot.

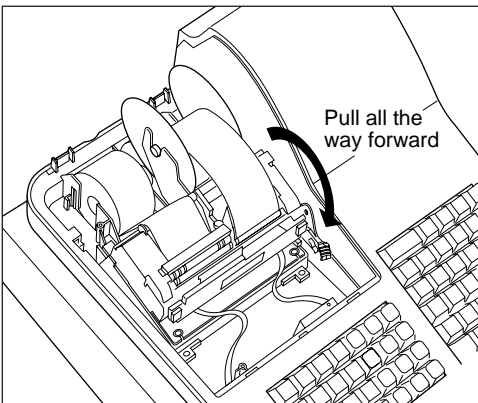

- 1.** Remove the printer cover.
- 2.** Pull the print head release lever all the way forward (after it stops at one position, continue pulling forward until it stops again and cannot be pulled forward any further).
- 3.** Remove the paper jam. Check for and remove any shreds of paper that may remain in the printer.
- 4.** Reset the paper roll correctly by following the steps in "Installing the paper roll".
- 5.** Return the print head release lever to its original position.
- 6.** Replace the printer cover.

6 Cleaning the print head

When the printed text is getting dark or faint, paper dust may be stuck to the print head. Clean the print head as follows:

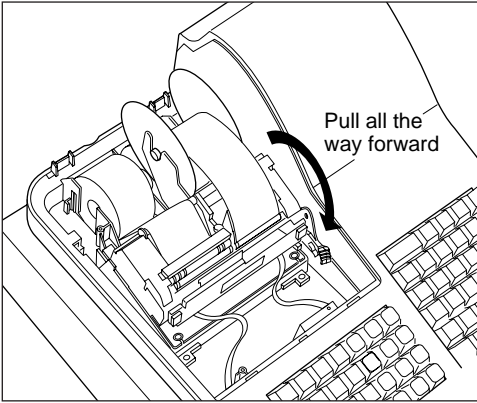

1. Turn the mode switch to the "⏻" position.
2. Remove the printer cover.
3. Pull the print head release lever all the way forward (after it stops at one position, continue pulling forward until it stops again and cannot be pulled forward any further).

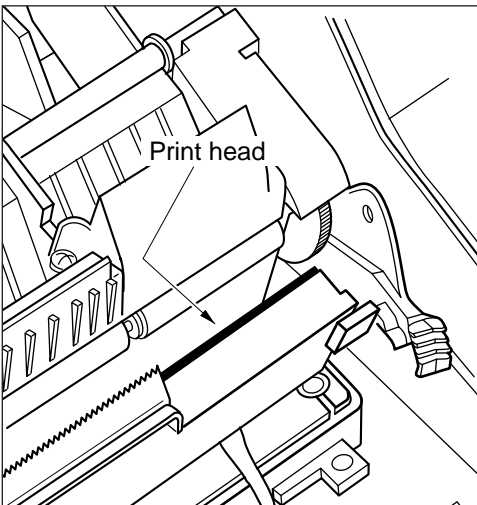

4. Clean the print head with a soft rag moistened with ethyl alcohol or isopropyl alcohol.
5. Return the print head release lever to its original position immediately after cleaning.
6. Replace the printer cover.

Precautions:

Never touch the print head with a tool or anything hard as it may damage the head.

7 Removing the till and the drawer

The till in the register is detachable. After closing your business for the day, remove the till from the drawer and keep the drawer open. The coin case is also detachable from the till. To detach the drawer, pull it forward fully with the till removed, and remove it by lifting it up.

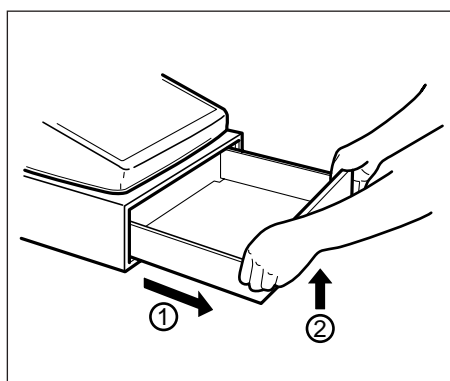
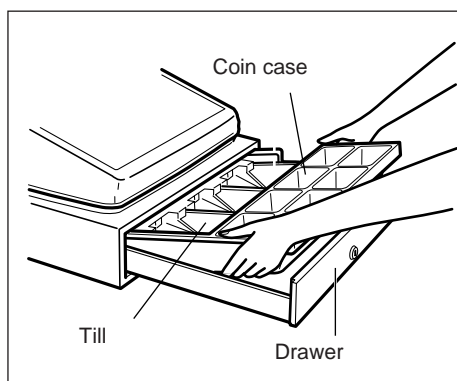

8 Opening the drawer by hand

The drawer automatically opens in the usual way. However, when power failure is encountered or the machine becomes out of order, slide the lever located on the machine bottom toward the rear. (See the figure below.) The drawer will not open, if it is locked with a drawer lock key.

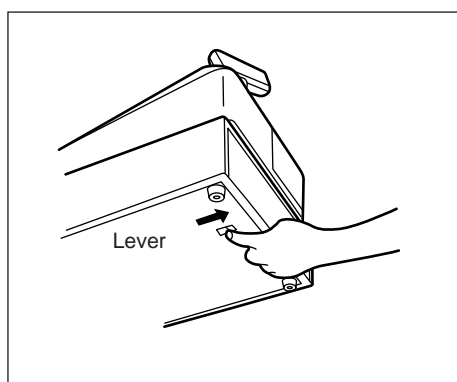

9 Installing the fixing angle bracket

To prevent the register from moving when the drawer opens, the fixing angle bracket is supplied with the register. By attaching the bracket to the table where the register is installed, you can hook the register on this bracket and secure the register to its position.

How to install the fixing angle bracket

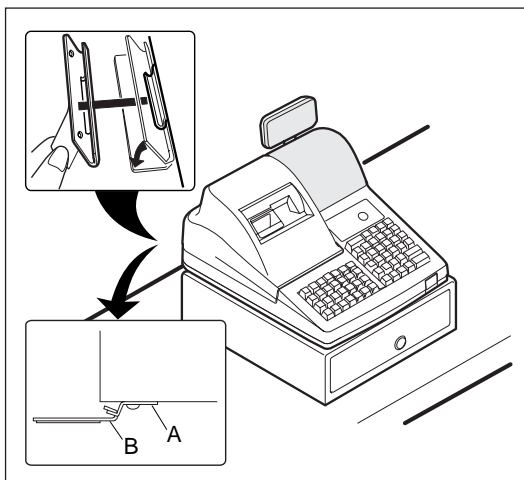

1. Thoroughly clean the location where the fixing angle bracket (B) is to be placed.
2. Peel off the adhesive tape on the fixing angle bracket.
3. Hook the angle bracket onto the hook (A) that is located at the bottom rear of the register.
4. Firmly stick the fixing angle bracket to the table surface that you cleaned above.

How to remove the register from the fixing angle bracket

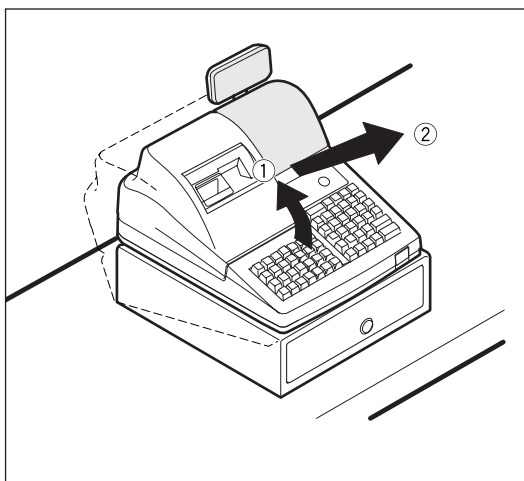

1. Lift up the front of the register and pull the register towards you.

10 Before calling for service

The malfunctions shown in the left-hand column below, labelled "Fault," do not necessarily indicate functional faults of the machine. It is therefore advisable to refer to the "Checking" shown in the right-hand column before calling for service.

Fault	Checking
(1) The display won't be illuminated even when the mode switch is turned to any other position than "ϕ".	<ul style="list-style-type: none"> • Is power supplied to the electrical outlet? • Is the power cord plug out or loosely connected to the electrical outlet?
(2) The display is illuminated, but the whole machine refuses registrations.	<ul style="list-style-type: none"> • Is a cashier code assigned to the register? • Is a clerk code assigned to the register? • Is the mode switch set properly at the "REG" position?
(3) No receipt is issued.	<ul style="list-style-type: none"> • Is the receipt paper roll properly installed? • Is there a paper jam? • Is the receipt function in the "OFF" status? • Is the print head release lever at the printing position?
(4) No journal paper is taken up.	<ul style="list-style-type: none"> • Is the take-up spool installed on the bearing properly? • Is there a paper jam?
(5) Printing is unusual.	<ul style="list-style-type: none"> • Is the print head release lever at the printing position? • Is the paper roll properly installed?

■ Error code table

When the following error codes are displayed, press the **CL** key and take a proper action according to the table below.

Error code	Error status	Action
E01	Registration error	Make a correct key entry.
E02	Misoperation error	Make a correct key entry.
E03	Undefined code is entered.	Enter a correct code, or declare it by the programming.
E04	Journal paper is nearly empty.	Replace a journal paper roll with a new one.
E05	Secret code error	Enter a correct secret code.
E07	Memory is full.	Expand the file within a capacity of memory.
E11	Compulsory depression of the ST key for direct finalization	Press the ST key and continue the operation.
E12	Compulsory tendering	Make a tendering operation.
E22	Overlapped cashier error	
E23	Cashier resetting over error	
E31	Compulsory non-add code entry	Enter a non-add code.
E32	No entry of your cashier code	Make a cashier code entry.
E33	The current cashier code should not be changed.	Change a cashier after finalizing the transaction.
E34	Overflow limitation error	Make a registration within a limit of entry.
E35	The open price entry is inhibited.	Make a preset price entry.
E36	The preset price entry is inhibited.	Make an open price entry.
E37	The direct finalization is inhibited.	Make a tendering operation.
E58	Undefined clerk code is entered.	Enter a correct clerk code.
E67	Registration buffer is full.	
E76	The drawer is still opened.	Close the drawer.

LIST OF OPTIONS

For your register, the following options are available.

For details, contact your dealer.

- RAM memory chip model ER-03RA
- Remote drawer model ER-05DW
- Till model ER-58CC and till cover model ER-03CV
- Coin case model ER-58CV
- EFT interface board model ER-01EF
- Key kit models

By using the following key kits, you can change the keyboard layout of your register including the expansion of the number of departments.

ER-11KT7: 30 regular size key kits

ER-12KT7: 30 1 x 2 size key kits

ER-22KT7: 10 2 x 2 size key kits

ER-11DK7G: 30 regular size dummy key kits

ER-51DK7G: 10 5 x 1 size dummy key kits

FOR CUSTOMERS IN U.K.

IMPORTANT

The wires in this mains lead are coloured in accordance with the following code:

BLUE:	Neutral
BROWN:	Live

As the colours of the wires in the mains lead of this apparatus may not correspond with the coloured markings identifying the terminals in your plug proceed as follows.

The wire which is coloured **BLUE** must be connected to the terminal which is marked with the letter **N** or coloured black.

The wire which is coloured **BROWN** must be connected to the terminal which is marked with the letter **L** or coloured red.

The apparatus must be protected by a 3A fuse in the mains plug or distribution board.

CAUTION: DO NOT CONNECT THE LIVE (BROWN) WIRE OR THE NEUTRAL (BLUE) WIRE TO THE EARTH TERMINAL OF YOUR 3-PIN MAINS PLUG.

Environment Protection

The device is supported by a battery. To dispose the battery safely to protect the environment, please note the following points:

- Take the used battery to your local waste depot, dealer or customer service centre for recycling.
- Do not throw the used battery into fire, into water or into the household waste!

Umweltschutz

Das Gerät wird durch eine Batterie gestützt. Um die Batterie sicher und umweltschonend zu entsorgen, beachten Sie bitte folgende Punkte:

- Bringen Sie die leere Batterie zu Ihrer örtlichen Mülldeponie, zum Händler oder zum Kundenservice-Zentrum zur Entsorgung.
- Werfen Sie die leere Batterie niemals ins Feuer, ins Wasser oder in den Hausmüll.

Protection de l'environnement

L'appareil est supporté sur pile. Afin de protéger l'environnement, nous vous recommandons de traiter la pile usagée la façon suivante:

- Apporter la pile usagée à votre centre de traitement des ordures ménagères le plus proche ou, à votre revendeur ou, au service après-vente, pour recyclement.
- Ne jamais jeter la pile usagée dans une source de chaleur, dans l'eau ou dans les vide-ordures.

Miljöskydd

Denna produkt nöddrivs av batteri.

Vid batteribyte skall följande iakttas:

- Det förbrukade batteriet skall inlämnas till er lokala handlare eller till kommunal miljöstation för återinsamling.
- Kasta ej batteriet i vattnet eller i hushållssoporna. Batteriet får ej heller utsättas för öppen eld.

SHARP®
SHARP CORPORATION