



ER-650/650R

Operation and Program Manual



All specifications are subject to change without notice

ATTENTION

The product that you have purchased contains a rechargeable Ni-MH battery. This battery is recyclable. At the end of its useful life, under various state and local laws, it may be illegal to dispose of the battery into the municipal waste system.

Check with your local solid waste officials for details concerning recycling options or proper disposal.



WARNING

This is a Class A product. In a domestic environment this product may cause radio interference in which case the user may be required to take adequate measures.

Precaution Statements

Follow these safety, servicing and ESD precautions to prevent damage and to protect against potential hazards such as electrical shock.

1-1 Safety Precautions

1. Be sure that all built-in protective devices are replaced. Restore any missing protective shields.
2. When reinstalling the chassis and its assemblies, be sure to restore all protective devices, including nonmetallic control knobs and compartment covers.
3. Make sure there are no cabinet openings through which people - particularly children - might insert fingers and contact dangerous voltages. Such openings include excessively wide cabinet ventilation slots and improperly fitted covers and drawers.
4. Design Alteration Warning:
Never alter or add to the mechanical or electrical design of the SECR. Unauthorized alterations might create a safety hazard. Also, any design changes or additions will void the manufacturer's warranty.
5. Components, parts and wiring that appear to have overheated or that are otherwise damaged should be replaced with parts that meet the original specifications. Always determine the cause of damage or over- heating, and correct any potential hazards.
6. Observe the original lead dress, especially near the following areas : sharp edges, and especially the AC and high voltage supplies. Always inspect for pinched, out-of-place, or frayed wiring. Do not change the spacing between comp-onents and the printed circuit board. Check the AC power cord for damage. Make sure that leads and components do not touch thermally hot parts.
7. Product Safety Notice:
Some electrical and mechanical parts have special safety-related characteristics which might not be obvious from visual inspection. These safety features and the protection they give might be lost if the replacement component differs from the original - even if the replacement is rated for higher voltage, wattage, etc.
Components that are critical for safety are indicated in the circuit diagram by shading, () or (). Use replacement components that have the same ratings, especially for flame resistance and dielectric strength specifications. A replacement part that does not have the same safety characteristics as the original might create shock, fire or other hazards.

CAUTION

Danger of explosion if battery is incorrectly replaced.

Replace only with the same or equivalent type recommended by the manufacturer.

Dispose used batteries according to the manufacturer's instructions.

ATTENTION

Il y a danger d'explosion s'il y a remplacement incorrect de la batterie.

Remplacer uniquement avec une batterie du même type ou d'un type équivalent recommandé par le constructeur.

Mettre au rebut les batteries usagées conformément aux instructions du fabricant.

1-2 Servicing Precautions

WARNING: First read the-Safety Precautions-section of this manual. If some unforeseen circumstance creates a conflict between the servicing and safety precautions, always follow the safety precautions.

WARNING: An electrolytic capacitor installed with the wrong polarity might explode.

1. Servicing precautions are printed on the cabinet. Follow them.
2. Always unplug the units AC power cord from the AC power source before attempting to:
 - (a) Remove or reinstall any component or assembly
 - (b) Disconnect an electrical plug or connector
 - (c) Connect a test component in parallel with an electrolytic capacitor
3. Some components are raised above the printed circuit board for safety. An insulation tube or tape is sometimes used. The internal wiring is sometimes clamped to prevent contact with thermally hot components. Reinstall all such elements to their original position.
4. After servicing, always check that the screws, components and wiring have been correctly reinstalled. Make sure that the portion around the serviced part has not been damaged.
5. Check the insulation between the blades of the AC plug and accessible conductive parts (examples : metal panels and input terminals).
6. Insulation Checking Procedure:

Disconnect the power cord from the AC source and turn the power switch ON. Connect an insulation resistance meter (500V) to the blades of AC plug.

The insulation resistance between each blade of the AC plug and accessible conductive parts (see above) should be greater than 1 megohm.
7. Never defeat any of the B+ voltage interlocks. Do not apply AC power to the unit (or any of its assemblies) unless all solid-state heat sinks are correctly installed.
8. Always connect an instrument's ground lead to the instrument chassis ground before connecting the positive lead ; always remove the instrument's ground lead last.

1-3 Precautions for Electrostatically Sensitive Devices (ESDs)

1. Some semiconductor (solid state) devices are easily damaged by static electricity. Such components are called Electrostatically Sensitive Devices (ESDs); examples include integrated circuits and some field-effect transistors. The following techniques will reduce the occurrence of component damage caused by static electricity.
2. Immediately before handling any semiconductor components or assemblies, drain the electrostatic charge from your body by touching a known earth ground. Alternatively, wear a discharging wrist-strap device. (Be sure to remove it prior to applying power - this is an electric shock precaution.)
3. After removing an ESD-equipped assembly, place it on a conductive surface such as aluminum foil to prevent accumulation of electrostatic charge.
4. Do not use freon-propelled chemicals. These can generate electrical charges that damage ESDs.
5. Use only a grounded-tip soldering iron when soldering or unsoldering ESDs.
6. Use only an anti-static solder removal device. Many solder removal devices are not rated as anti-static; these can accumulate sufficient electrical charge to damage ESDs.
7. Do not remove a replacement ESD from its protective package until you are ready to install it. Most replacement ESDs are packaged with leads that are electrically shorted together by conductive foam, aluminum foil or other conductive materials.
8. Immediately before removing the protective material from the leads of a replacement ESD, touch the protective material to the chassis or circuit assembly into which the device will be installed.
9. Minimize body motions when handling unpackaged replacement ESDs. Motions such as brushing clothes together, or lifting a foot from a carpeted floor can generate enough static electricity to damage an ESD.

Contents

Getting Started	1
About the <i>ER-650/650R</i>	1
Using this Manual.....	2
Unpacking.....	2
Installing the Paper	3
Basic Features and Functions	6
Standard Hardware	6
Optional Hardware	6
Software Features	6
ER-650 Default Keyboard.....	8
ER-650 Program Overlay	8
ER-650R Default Keyboard	9
ER-650R Program Overlay	9
Programmable Function Keys	10
Control Lock	14
Front Display.....	15
Rear Display.....	18
Initial Clear	19
Operating Instructions	21
Operator Display Screen.....	21
Operator Display Example	22
Clerk Operations.....	23
Clerk Sign On Instructions	24
Clerk Sign Off Instructions	24
Clerk Time Keeping	25
Item Registrations.....	27
Open Keyboard PLU Entry	28
Preset Price Keyboard PLU.....	28
Keyboard PLU Repeat Entry.....	29
Keyboard PLU Multiplication.....	30
Keyboard PLU Multiplication with Decimal Point	31
Split Pricing (Keyboard PLU).....	32
Single Item Keyboard PLU	33
Open Code Entry PLU	34
Preset Price Code Entry PLU	34
Code Entry PLU Multiplication	35
Code Entry PLU Multiplication with Decimal Point	36
Split Pricing Code Entry PLU	36
PLU Price Inquiry	37
Modifier Key	38
Price Level Key.....	39
Promo	40

Waste	41
Shifting or Exempting Tax	42
Shifting Tax	42
Exempting Tax	43
Percent Key Operations	45
Preset Percent Discount on an Item	45
Enter a Percent Discount on an Item	46
Percent on Sale Total	46
Coupon on Sale (Vendor Coupon)	47
Coupon on Item (Store Coupon)	48
Return Merchandise Registrations	49
Voids and Corrections	50
Error Correction (Void Last Item)	50
Void Previous Item	50
Cancel	51
Void Position Operations	51
No Sale Operations	52
Open Drawer	52
Non Add Number	52
Received On Account Operations	53
Paid Out Operations	54
Subtotaling a Sale	55
Eat In/Take Out/Drive Thru Sales	55
Totaling and Tendering	56
Totaling a Cash Sale	56
Totaling a Check Sale	56
Tendering a Cash Sale	57
Tendering a Check Sale	57
Totaling a Charge Sale	58
Tendering a Charge Sale	59
Check Cashing	60
Split Tender	61
Post Tender	62
Food Stamp Sales	63
Currency Conversion	64
Receipt On/Off and Receipt on Request	65
Check Tracking Operations	66
Overview	66
Posting Balances Manually	68
Soft Check	70
Hard Check	73
Fast Food Drive Thru	76
Scale Operations	78
Direct Scale Entry	79
Automatic Scale Entry	80
Tare Weight Entry	80
Manual Tare Weight Entry	81
Manual Weight Entry	82

X Mode

83

Manager Mode	83
Manager Operation	84
X Reports	85
Declaration	87

Register Print Format.....	88
Stop Register Printing.....	89
Training Mode.....	90
E.J. Operation.....	91

Z Mode 93

Reset Report Mode.....	93
Z Reports.....	94
Reset Electronic Journal.....	96
PC Communication.....	96
PLU Lookup Program.....	97
Age Verification.....	99
KP Starting No.....	100

Service Mode Programming 101

Overview.....	101
Clearing Memory.....	103
Memory All Clear.....	103
Hardware Test.....	105
Hardware Test Table.....	105
Clear All Totals.....	106
Clear Grand Total.....	106
Clear PLU File.....	107
EPROM Information.....	107
Memory Allocation.....	108
Function Key Assignment.....	110
Function Key Codes.....	112
IRC Options.....	113
RS232C Port 1/RS232C Port 2 Options.....	114
RS232C Settings Screen Program Notes.....	117

Program Mode Programming 119

Descriptor Programming Methods.....	119
Program Overlay Method.....	119
Descriptor Code Method.....	120
Program Mode Menu.....	121
PLU Programming.....	123
Add/Modify PLU.....	123
PLU Options - Reference Information.....	126
Delete PLU.....	128
Group Programming.....	131
Sales Tax Programming.....	134
Programming an Add-On Tax Rate Percentage.....	135
Programming a Tax Table.....	136
Programming a VAT (Value Added Tax).....	140
Programming a Canadian GST.....	141
System Option Programming.....	142
System Options - Reference Information.....	146
Print Option Programming.....	150
Clerk Programming.....	158
Clerk Programming - Reference Information.....	159
Function Key Programming.....	160
#/NS.....	161

% 1 -%5	163
ADD CHECK.....	166
CANCEL.....	168
CASH.....	169
CHARGE 1-8.....	171
CHECK CASHING.....	173
CHECK ENDORSEMENT.....	174
CHECK.....	176
CHECK #.....	178
CURRENCY CONVERSION 1-4.....	180
EAT-IN TAKE OUT DRIVE THRU.....	181
ERROR CORRECT.....	182
F/S TEND.....	183
FUNCTION LOOK UP (1-2).....	185
GUEST.....	187
LEVEL 1-5.....	188
MDSE RETURN.....	189
MODIFIER 1-5.....	190
PBAL.....	192
PAID OUT 1-3.....	193
PRINT CHECK.....	194
PROMO.....	195
RECD ON ACCT 1-3.....	196
SCALE.....	197
SERVICE.....	199
TABLE.....	201
TARE.....	202
TAX EXEMPT.....	203
TIME IN/OUT.....	204
TIP.....	205
VALIDATE.....	207
VOID ITEM.....	208
WASTE.....	209
Logo Descriptor.....	210
Preamble.....	211
Postamble.....	212
Endorsement Message.....	213
Financial Report.....	214
Clerk Report.....	215
Macro Name.....	216
NLU Code Number.....	217
Download Programs.....	218
Clerk In/Out.....	220
PLU Stock.....	221
Drawer Limit.....	222
Check Change Limit.....	223
Time & Date.....	224
Tare Weight.....	225
Macro.....	226
Programming a New Macro.....	227
Editing an Existing Macro.....	228
Machine No.	229
PC Schedule Time.....	230
Training Mode Password.....	231
Program Scans.....	232

Sample Reports	235
Financial	235
Time	239
PLU.....	240
Clerk	241
Individual Clerk	242
Groups	243
Stock	244
Clerk Time Report	245
Check File.....	246
PLU Zero Sale	247
Balancing Formulas	248
 Glossary of Terms	 249
 Index	 255

Getting Started

About the *ER-650/650R*

Congratulations! You have selected a very flexible electronic cash register designed for years of reliable service. The *ER-650/650R* will fit many shops and restaurants, providing fast transaction processing, security, and detailed sales information.

The *ER-650/650R* features a unique operator screen that allows you to view itemized transaction information, as well as providing on screen programming that is simple and easy to use. The raised-key keyboard has 78 individual key locations. All locations are programmable so that your dealer can customize the keyboard to fit your needs exactly.

Using this Manual

This manual provides the sequences and reference information required to set up and operate your *ER-650/650R*.

In this Manual you will find:

- "Getting Started" - Before you begin, please review the information in this chapter carefully, including:
 - ⇒ Unpacking and initial setup,
 - ⇒ The basic features and capabilities of your *ER-650/650R*.
- "Operating Instructions" - Step by step operating sequences for your *ER-650/650R*.
- "X Mode" - Manager procedures, including X reports are detailed here.
- "Z Mode" - Z (reset) reports are detailed.
- "Service Mode Programming" - In the service mode, you can perform hardware tests, then complete one-time set up procedures that will ready your *ER-650/650R* for use.
- "Program Mode Programming" - All routine programming procedures, including PLU, function key, system options and sales tax programming are performed in Program Mode.
- "Sample Reports" - A sample of each report is provided.

Unpacking

1. Unpack and unwrap the cash register.
2. Located in the packing are the following items:
 - 1 roll of paper and paper spindle,
 - 2 sets of control keys,
 - Operation and Program Manual,
 - 1 ferrite core for use with optional IRC cable. (See instructions included with IRC cable.)
3. Remove the cardboard protectors from the cash drawer.
4. Plug the register into a grounded outlet (three prong), insert a control key and turn the key to the **REG** control lock position.

Installing the Paper

ER-650

1. Remove the printer cover.
2. For proper feeding through the print head, cut or tear a straight even edge on the end of the paper roll. (Be sure to remove any paper with glue residue.) Place the paper roll in the paper holder so that the paper will feed from the bottom of the roll.

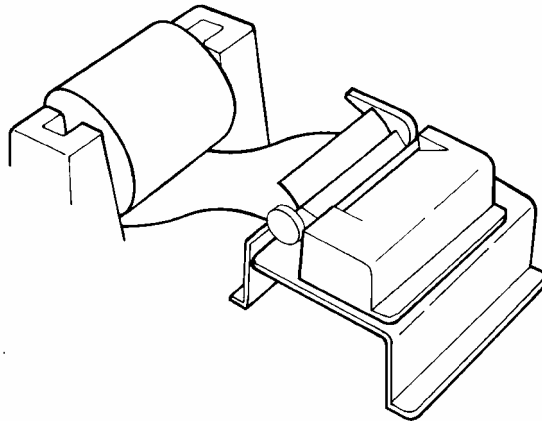

3. Insert the end of the paper into the paper slot.
4. Press the **PAPER FEED** key until the paper comes out about 8 inches.
5. Pass the paper through the window of the printer cover and replace the printer cover.

ER-650R

1. Remove the printer cover.

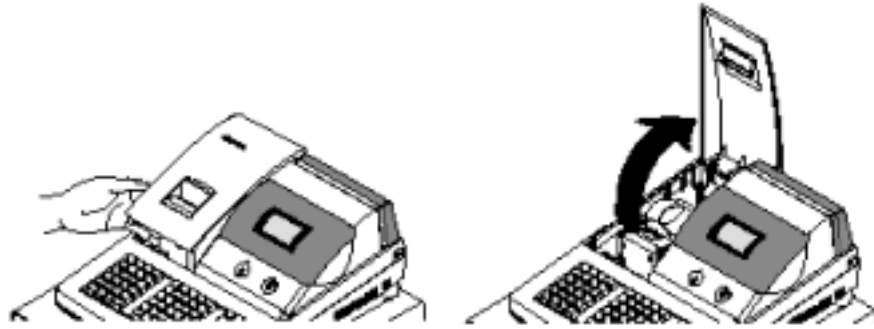

2. Push the blue cap lever and then lift up to open the paper cover.

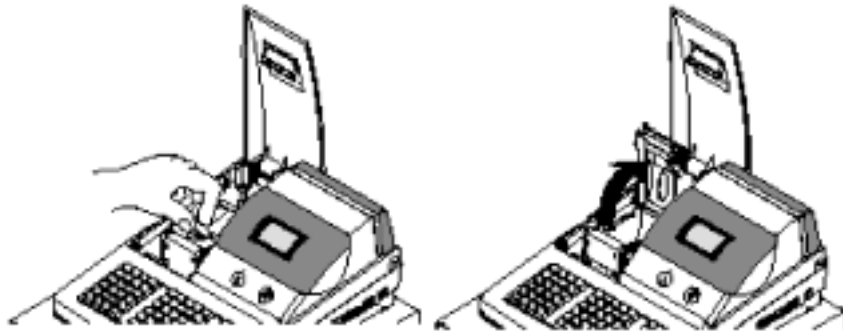

3. Ensure that the paper is being fed from the bottom of the roll.



4. Put the leading edge of the paper over the printer.
5. Close the paper cover slowly until it locks firmly



6. Passing the leading edge of the paper through the cutter slot. Tear off the excess paper. Replace the printer cover.

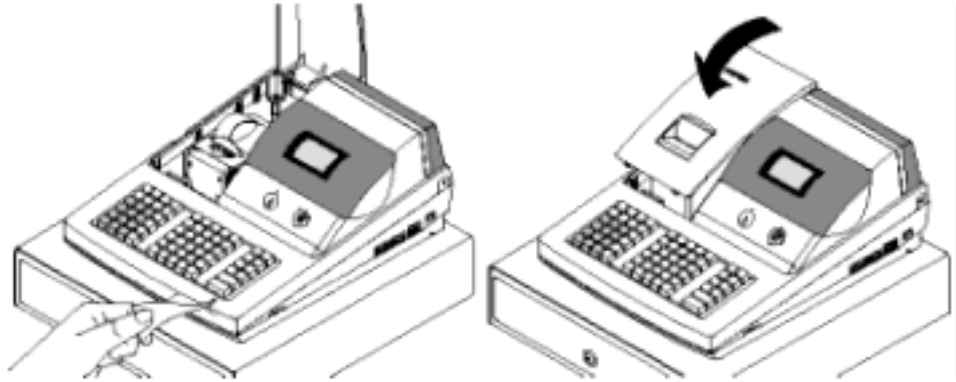

Basic Features and Functions

Standard Hardware

- Adjustable 8-line, 20-character liquid crystal display.
- Keyboard
 - ⇒ ER-650 : Flat spill resistant 98 position.
 - ⇒ ER-650R : Raised 64 position.
- Thermal 32-column printer with drop-and-print mechanism.
- Sturdy Metal Cash Drawer with removable 5 Bill/5 Coin drawer insert.
- 7-position control lock.
- Standard customer pole display.
- Communications ports: 2 RS232C & IRC.

Optional Hardware

- Load cell scale.
- Kitchen printer or video requisition system.
- Bar code scanner.
- Coin changer.
- Pole Display.
- Liquor dispensing system.
- Real clerk keys and lock assembly for 15 clerks.
- Lan Tran credit card terminal.

Software Features

- Keyboard NLU keys.
 - ⇒ ER-650 : 63 standard/80 maximum
 - ⇒ ER-650R : 30 standard/69 maximum
- Up to 5 price levels for each PLU.
- Up to 5 PLU modifier keys (i.e. small, medium, and large).
- Over 10,000 Price Look Ups (PLUs) are available. (The total number of PLUs available varies by memory allocation. Ask your dealer for more information.) To accommodate UPC scanning, each PLU can be given an identifying number up to 14 digits in length.
- 12 character programmable descriptors for PLUs and functions.

- Up to 99 PLU Group totals.
- Up to 99 clerks with separate report totals.
- Employee time keeping functions for each clerk.
- Four tax rates with value added tax (VAT) capability. Each tax rate is programmable for tax table look-ups and/or straight percentage tax programming. Tax rate 4 can be programmed to accommodate Canadian goods and services tax (GST).
- Programmable functionality for each key location.
- 24-hour real-time clock with automatic day and date change.
- Check, Cash, and up to 8 charge tender functions.
- Currency conversion capability for calculating sale totals in foreign currency (for up to 4 foreign currencies.)
- Training mode.
- Food stamp sorting and tendering.
- Programmable discount/surcharge/coupon keys.
- Insure accuracy with Error Correct, Void, Cancel and Void Transaction functions.
- Function keys for posting charges and payments to accounts or guest checks. You can choose manual previous balance posting as well as hard or soft check tracking. (Check capacity is determined by memory allocation.)
- Macro, Function Look-up, Price Inquiry, Promo and Waste functions.
- Management reports, with the capability to view most reports on the register display.
- Electronic Journal capability, where transaction information can be captured in register memory for printing at a later time. (Capacity is determined by memory allocation.)
- 6-line programmable preamble and postamble messages.
- 10-line programmable check endorsement message.
- Programmable descriptors for financial and clerk reports.
- Up to 8 PLU look-up keys, each key can display up to eight PLUs for quick registration.
- Age verification feature that requires the operator to enter the customer's date of birth before selected items can be registered.

ER-650 Default Keyboard

1	8	15	22	29	36	43	50	57	PAPER FEED	#/NS	VOID ITEM	ERROR CORR	CLERK #
2	9	16	23	30	37	44	51	58	TAX 1 SHIFT	PAGE UP	YES/NO	PAGE DOWN	ADD CHECK
3	10	17	23	31	38	45	52	59	LEVEL 1	CLEAR ESC	PLU	@/FOR PRTSCR	FUNCTION LOOK-UP1
4	11	18	24	32	39	46	53	60	LEVEL 2	7	8	9	FUNCTION LOOK-UP2
5	12	19	26	33	40	47	54	61	% 1	4	5	6	CHECK
6	13	20	27	34	41	48	55	62	% 2	1	2	3	SBTL
7	14	21	28	35	42	49	56	63	% 3	0	00	.	CASH ENTER

FUNCTION LOOK-UP 1 MENU FUNCTION LOOK-UP 2 MENU

1. CANCEL
2. MDSE RETURN
3. RA1
4. PO1
5. TIP
6. TAXEXMT
7. CONV1
8. TIME IN/OUT

1. CHARGE 1
2. CHARGE 2
3. CHARGE 3
4. CHARGE 4
5. CHARGE 5
6. CHARGE 6
7. CHARGE 7
8. CHARGE 8

ER-650 Program Overlay

									PAPER FEED				
!	@	#	\$	%	^	&	*	()	PAGE UP	YES/NO	PAGE DOWN	
Q	W	E	R	T	Y	U	I	O	P	CLEAR ESC	PLU	@/FOR PRTSCR	
A	S	D	F	G	H	J	K	L		7	8	9	
Z	X	C	V	B	N	M	,	.	/	4	5	6	
CAPS	DOUBLE	SPACE	SPACE	SPACE	SPACE	SPACE	CAPS	CAPS	BACK SPACE	1	2	3	SBTL
:	=	;	'	?	<	>	-	+	"	0	00	.	CASH ENTER

ER-650R Default Keyboard

PAPER FEED	PAGE UP	PAGE DOWN	TAX 1 SHIFT	1	7	13	19	25	FUNCTION LOOK-UP1	CLERK #
CLEAR ESC	@/FOR PRN/SCR	PLU	#/NS	2	8	14	20	26	FUNCTION LOOK-UP2	YES/NO
7	8	9	VOID ITEM	3	9	15	21	27	MACRO 1	MACRO 2
4	5	6	ERROR CORR	4	10	16	22	28	ADD CHECK	CHECK
1	2	3	% 1	5	11	17	23	29	SBTL	
0	00	.	% 2	6	12	18	24	30	CASH/ENTER	

FUNCTION LOOK-UP 1 MENU

1. CANCEL
2. MDSE RETURN
3. RA1
4. PO1
5. TIP
6. TAXEXMT
7. CONV1
8. TIME IN/OUT

FUNCTION LOOK-UP 2 MENU

1. CHARGE 1
2. CHARGE 2
3. CHARGE 3
4. CHARGE 4
5. CHARGE 5
6. CHARGE 6
7. CHARGE 7
8. CHARGE 8

ER-650R Program Overlay

Refer to "Descriptor Programming" on page 119 to use either the Program Overlay Method or the Descriptor Code Method of programming descriptors.

PAPER FEED	PAGE UP	PAGE DOWN	BACK SPACE	A	G	M	S	Y	()/-
CLEAR ESC			DOUBLE	B	H	N	T	Z	+/= YES/NO
7	8	9	SPACE	C	I	O	U	!/@	</, >./
4	5	6	SPACE	D	J	P	V	#/\$	"/' ?//
1	2	3	SPACE	E	K	Q	W	%/^	:/;
0	00	.	CAPS	F	L	R	X	&/*	ENTER

Programmable Function Keys

Functions can be assigned as necessary from the list that follows into any keyboard location.

Key Descriptions

KEY	Description
NUMERIC KEYPAD: 0-9, 00, AND DECIMAL	Use the numeric keypad to enter amounts and other numeric values. The decimal key is used for decimal multiplication, when setting or entering fractional percentage discounts, or when programming fractional tax rates. Do not use the decimal key when making amount entries into PLUs or tendering.
NLU 1 - NLU 80	Use any of the 80 NLU keys to categorize merchandise (as you would with traditional department keys.) NLUs can be programmed to access any PLU number in the register.
#/NS	Press to open the cash drawer when you have not already started a transaction. Also, can be used to print any non-adding number (up to 9 digits) on the printer paper.
%1 -%5	Up to five % keys may be placed on the keyboard. Each % key is set with a specific function, such as item discount or surcharge, or sale discount or surcharge. The percent rate may be entered or preprogrammed, or the percent keys can be programmed with a negative open or preset price, thus acting as coupon keys.
@/FOR (PRT SCREEN)	Enter a quantity, then press the @/FOR key to enter multiple items. Also use to enter "split pricing" items, such as 1 item at 3 for \$.89. When pressed directly, the @/FOR key will cause the information displayed on the screen to be printed. (The print screen function is allowed or disallowed by a system option.)
ADD CHECK	Use to combine individual trays (in a cafeteria situation) that will be paid together. Each tray subtotal can advance the consecutive number, depending on programming.
CANCEL	Press CANCEL to void (or erase) all items entered thus far in any transaction.
CASH (ENTER)	Press to total a transaction paid by cash. Also, if the cash amount tendered is over the amount purchased, enter the amount of the tender, then press the CASH key. The drawer will open and the cash change will be computed. The CASH key doubles as an ENTER key. When you are performing manager functions, or programming, use the ENTER key to advance to the next item or screen.
CHARGE 1-8	Use to finalize charge sales. Calculates the sale total including tax, finalizes the sale, and opens the cash drawer. Change computation may be allowed by entering an amount before pressing the CHARGE key. The cash drawer will open only if the amount tendered is equal to or greater than the total amount of the sale. Change issued will be subtracted from the cash-in-drawer total.
CHECK CASHING	Use to exchange a check for cash. Cash-in-drawer and check-in-drawer totals are adjusted.

KEY	Description
CHECK ENDORSEMENT	Use to print a check endorsement message on an optional slip printer. A programmable message up to 10 lines can also be printed.
CHECK	Press to total a transaction paid by check. Also if the check amount is over the amount purchased, enter the amount of the check, then press the CHECK key. The drawer will open and the cash change will be computed.
CHECK #	The CHECK # key is used to begin a new, or access an existing balance (hard check) or itemized bill (soft check.) Check track numbers that are entered manually may be set at a fixed length of one to nine digits. Check track numbers assigned automatically will begin with #1. Existing checks are accessed by entering the check track number and pressing the CHECK # key.
CLEAR (ESC)	Press to clear numeric errors made on keyboard prior to pressing the registration key. Also press to stop the error alarm when incorrect entries are made. The CLEAR key doubles as an ESC (Escape) key. When you are performing manager functions, or programming, use the ESC key to back up, or return to the previous screen.
CLERK #	Use to sign on or sign off a clerk.
CURRENCY CONVERSION 1-4	The currency conversion function, allowed after subtotal, converts and displays the new subtotal at a preprogrammed exchange rate. Tendering is allowed after using the currency conversion function. Change is calculated and issued in home currency. The amount of foreign currency tendered is stored in a separate total on the Financial report, but not added to the drawer total.
EAT-IN TAKE OUT DRIVE THRU	Eat-In, Take Out and Drive Thru are subtotal functions. In areas that have different tax rules for eat-in and take out sales, the EAT-IN , TAKE OUT and DRIVE THRU keys can be programmed to automatically charge or exempt taxes. Sales may not be split between Eat-In, Take Out and Drive Thru. The EAT-IN , TAKE OUT and DRIVE THRU keys maintain separate totals on the Financial report.
ERROR CORRECT	Press to void (or erase) the last item entered.
F/S SHIFT	When pressed before a PLU entry, the F/S SHIFT key reverses the preprogrammed food stamp status of the PLU. For example, an item not food stamp eligible can be made food stamp eligible.
F/S SUB	Displays the amount of the sale that is food stamp eligible.
F/S TEND	Use to tender food stamps for eligible sales.
FUNCTION LOOK UP (1-2)	Press a function look up key to display a list of functions that may not be located on the keyboard. Up to 8 functions can be listed on a function look up screen.
GUEST	Use to enter the count of guests served as part of a guest check. The entry of a guest count can be enforced when opening a guest check, or for all transactions.

KEY	Description
MACRO 1-10	Macro keys may be programmed to record, then later perform, up to 50 keystrokes. For example, a macro key could be set to tender (preset tender) a common currency, such as \$5 into the cash key.
MDSE RETURN	Used to return or refund merchandise. Returning an item will also return any tax which may have been applied.
MODIFIER 1-5	The MODIFIER key alters the next PLU registered, either by changing the code number of the PLU so that a different item is registered, or by adding the modifier descriptor (and not changing the code of the subsequent PLU.)
PBAL	Use to enter the amount of an outstanding balance. The PBAL key will take the recall function if the <i>drive thru</i> feature is enabled in CHECK # key programming.
PAGE DOWN	When transactions contain more items than can be displayed on the screen at one time, press the PAGE DOWN key to view items at the end of the transactions.
PAGE UP	When transactions contain more items than can be displayed on the screen at one time, press the PAGE UP key to view items at the beginning of the transactions.
PAID OUT 1-3	Use to record money taken from the register to pay invoices, etc. The paid out amount subtracts from the cash-in-drawer total. Paid outs are allowed outside of a sale only
PAPER FEED	Press to advance the printer paper.
PLU	Use to register a Price Look Up (PLU) that is not located on the keyboard.
PLU LOOK UP 1-8	Use PLU LOOK UP keys to view a list of up to 8 PLUs on the display. With the PLU list in view, a PLU can be registered by pressing the digit representing the PLU. Up to eight PLU LOOK UP keys can be placed on the keyboard.
PRICE INQUIRY	Use to display the descriptor and price of a PLU without registering the price.
PRICE LEVEL (1- 5)	Price Level keys shift the price PLU that is being registered. Levels can be <i>stay down</i> ; <i>pop-up after each item</i> to register, for example large, medium or small soft drink; <i>pop-up after each transaction</i> to register, for example, toppings of various pizza sizes.
PRINT CHECK	Use to print a guest check. The check can be printed on an optional (RS-232C) printer, or can be printed on the receipt printer. The PRINT CHECK key can be set to automatically service the check.
PROMO	The PROMO key allows you to account for promotional items, as in "buy two, get one free". Pressing this key will remove an item's cost from the sale, but will include the sale of the item in the item's sales counter.
RECD ON ACCT 1-3	The RECD ON ACCT (received on account) key is used to record media loaned to the cash drawer, or payments received outside of a sale. The cash drawer will open. The amount received adds to the cash-in-drawer total.
SBTL	Press once to display the sale subtotal.

KEY	Description
SCALE	Use to make weight entries. When a scale is attached, press the scale key to show the weight in the display, then press (or enter) a PLU to multiply the weight times the price. When a scale is not attached, you can manually enter the weight (using the decimal key for fractions). PLUs may be programmed to require an entry through the scale key.
SERVICE	Use to temporarily finalize Previous Balance or check tracking transactions.
TABLE	You can enforce the entry of a table number for guest check transactions, or for all transactions. If you are tracking guest check balances, the balance can be recalled either by entering the check number or the table number.
TARE	Tares are container weights. If you are using the scale function, you can preset up to 5 different tare weights. The tare can be subtracted automatically when a specific PLU is registered, or the tare can be subtracted by manually inputting the tare number and pressing the TARE key. Tare #5 can be programmed for entering tare weights manually.
TAX EXEMPT	Press the TAX EXEMPT key to exempt tax 1, tax 2, tax 3, and/or tax 4 from the entire sale.
TAX SHIFT 1-4	Press to reverse the programmed tax status of a PLU. For example, by pressing the appropriate TAX SHIFT key prior to registering a taxable item, the item will be sold without sales tax added.
TIME IN/OUT	Use to track hours worked by an employee, as would be done by a time clock.
TIP	The TIP key allows a gratuity to be added to a guest check before payment. The tip amount is deducted from the Cash-in-Drawer amount for the Clerk/Cashier closing the guest check. The TIP key may be programmed as either a percentage or amount. If programmed as a percentage, tax programming defines whether the percentage is calculated on the net amount, or the amount after taxes.
VOID ITEM	Use to void an item previously entered within a transaction by pressing VOID , then re-entering the item you wish to remove.
WASTE	The WASTE key allows control of inventory by accounting for items which must be removed from stock due to spoilage, breakage or mistakes. Press the WASTE key before entering wasted items, then press the WASTE key again to finalize. The WASTE key may be under manager control, requiring the control lock to be in the X position. The WASTE key is not allowed within a sale.
YES/NO	Press to toggle from Y (yes) to N (no) when selecting program options.
VALIDATION	Press to initiate a single line validation. Note that an optional printer with validation capability must be attached to the <i>ER-650/650R</i> and identified.

Control Lock

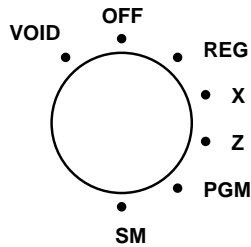

VOID	Use to void (correct) items outside of a sale.
OFF	The register is inoperable.
REG	Use for normal registrations.
X	Use to read register reports and perform other manager functions.
Z	Use to read register reports and reset totals to zero.
PGM	Use to program the register.
SM	Service Mode used for tests and special settings.

The *ER-650/650R* includes two sets of keys that can be used to access the following key lock positions.

<u>Key</u>	<u>Positions Accessible</u>
VD	VOID, OFF, REG, X
REG	OFF, REG
Z	OFF, REG, X, Z
P	VOID, OFF, REG, X, Z, PGM
C	ALL POSITIONS

Note: Keys can be removed from the key lock in the OFF or REG positions.

Front Display

The front display is a liquid crystal screen, allowing you to view up to 8 lines of information with up to 20 characters per line. The display is backlit and adjustable to provide excellent visibility, regardless of lighting conditions.

When the control lock is in the **OFF** position, the message **OFF MODE** is displayed and the register can not be operated. When the control lock is in the **REG** or **VOID** positions the appropriate message, **VOID MODE** or **REG MODE** is displayed with the message "CLOSED". You must sign on a clerk to remove the "CLOSED" message and begin operation. When the control lock is in the **X**, **Z**, **PGM** or **SM** positions, the appropriate menu is displayed.

OFF

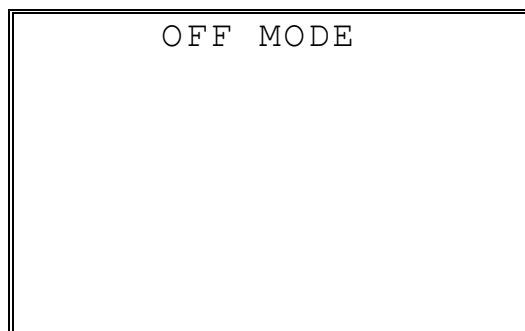

REG

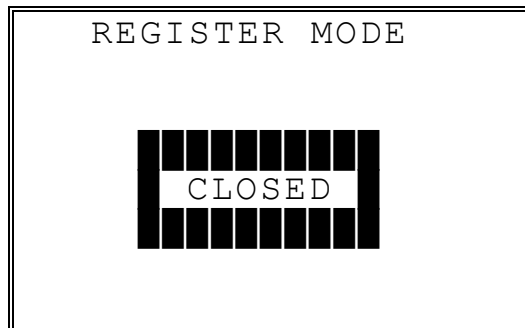

VOID

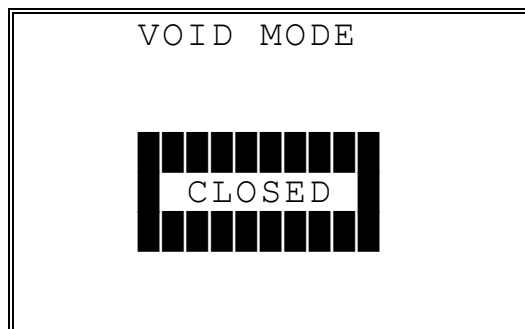

PGM

```
PROGRAM MODE ↓
0.PLU
1.GROUP
2.SALES TAX
3.SYSTEM OPTION
4.PRINT OPTION
5.FUNCTION KEYS
6.CLERK
```

- ◆ Press **PAGE DOWN** to view the remainder of the PROGRAM MODE menu:

```
PROGRAM MODE ↑
7.LOGO DESC.
8.NLU CODE# PGM.
9.DOWNLOAD PROGRAMS
00.MORE
```

- ◆ Press **00** to view the MORE PROGRAMS menu:

```
PROGRAM MODE page2 ↓
0.CLERK I/O
1.PLU STOCK
2.DRAWER LIMIT
3.CHECK CHANGE LIMIT
4.TIME & DATE
5.TARE WEIGHT
6.MACRO
```

- ◆ Press **PAGE DOWN** to view the remainder of the PROGRAM MODE page 2 menu:

```
PROGRAM MODE page2 ↑
7.MACHINE NO.
8.PC SCHEDULE TIME
9.TRAINING MODE P/W
00.SCAN
```

SM

```
SERVICE MODE  ↓
0. HW TEST
1. CLEAR ALL TOTALS
2. CLEAR GRAND TOTAL
3. CLEAR PLU FILE
4. EPROM INFO.
5. MEMORY ALLOCATION
6. KEY ASSIGNMENT
```

- ◆ Press **PAGE DOWN** to view the remainder of the SERVICE MODE menu:

```
SERVICE MODE  ↑
7. IRC OPTIONS
8. RS232C PORT 1
9. RS232C PORT 2
```

Rear Display

The rear display is a 10 digit florescent display that allows your customer to monitor the transaction and view the sale total. The rear display can be lifted and turned for easy customer viewing.

Rear Display Information

Item Count	The number of times an item has been repeated is displayed.
Amount	The amount of the item, subtotal or total, is displayed in the rightmost portion of the display.

Rear Display Messages

C	Change Due
-	Negative entry
Sub	Subtotal of the sale
=	Total of the sale

Initial Clear

CAUTION: Do not share this information with unauthorized users. Distribute the P-Mode key only to those you may want to perform this function.

The initial clear function allows you to exit any register activity and return to a beginning or cleared state. Any transaction that is in progress will be exited and totals for that transaction will not be updated.

Here are some reasons you may want to perform an initial clear:

- The register is in an unknown state, and you wish to exit the current program or transaction without following normal procedures.
- You have performed a function that includes a compulsory activity, such as validating or printing, and you wish to bypass the compulsory activity.
- An initial clear may be necessary as part of servicing, or troubleshooting a *ER-650/650R* register or system.

Perform this procedure only as necessary. Contact your dealer first if you have questions about operating or programming your *ER-650/650R*.

To Perform an Initial Clear:

1. Turn the power switch located on the right side of the register to the OFF position.
2. Turn the control lock to the **PGM** position.
3. Press and hold the key position where the **SBTL** key is located on the default keyboard layout.
4. While continuing to hold the **SBTL** key, turn the power switch to the ON position.
5. The message "INITIAL CLEAR SERV". will display momentarily when the initial clear is complete.

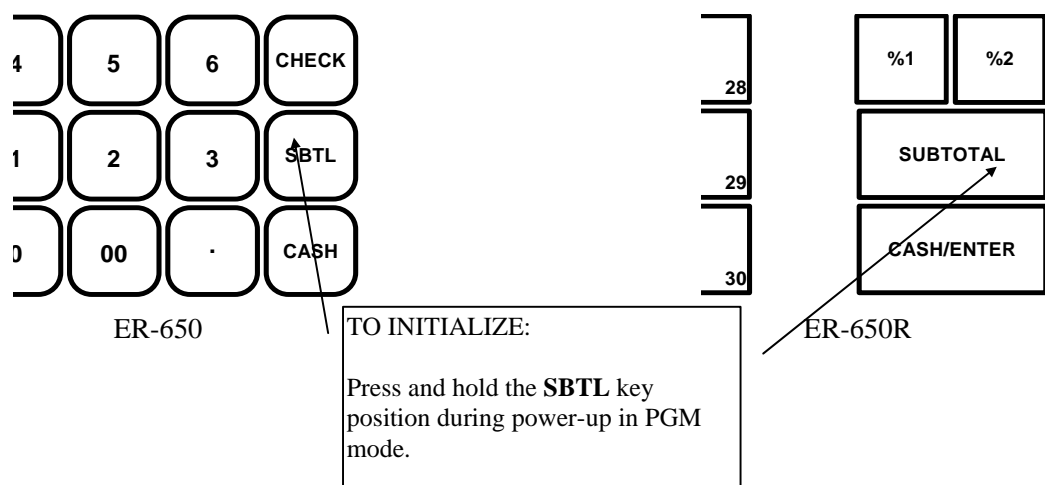

Operating Instructions

Operator Display Screen

The *ER-650/650R* Electronic Cash Register has a liquid crystal display screen, providing up to 8 lines of information with up to 20 characters per line. The display is backlit to provide excellent visibility, regardless of lighting conditions. Display screen contrast may be adjusted with the contrast adjustment, located on the right front corner of the register.

The multiple line screen lets you keep track of each item, as it is registered. For example:

- When you are operating the register (in the **REG** or **VOID** control lock positions), you can view a list of items that have been registered, as well as continuous tax and sale subtotals.
- If an item is multiplied, or repeated, the display lists the quantity of the item sold. (Note: Only quantities up to 99 are displayed in the quantity field.)
- Up to six items can be displayed simultaneously. When more than six items are registered, the display lists the last six items sold.
- You can scroll through long transactions with the **PAGE UP** and **PAGE DOWN** keys. When more than six items have been registered, you can press the **PAGE UP** key to view items registered earlier in the sale. Press the **PAGE DOWN** key to return to a view of the items registered later in the transaction.
- If you make an error, the screen specifies the type of error.

Operator Display Example

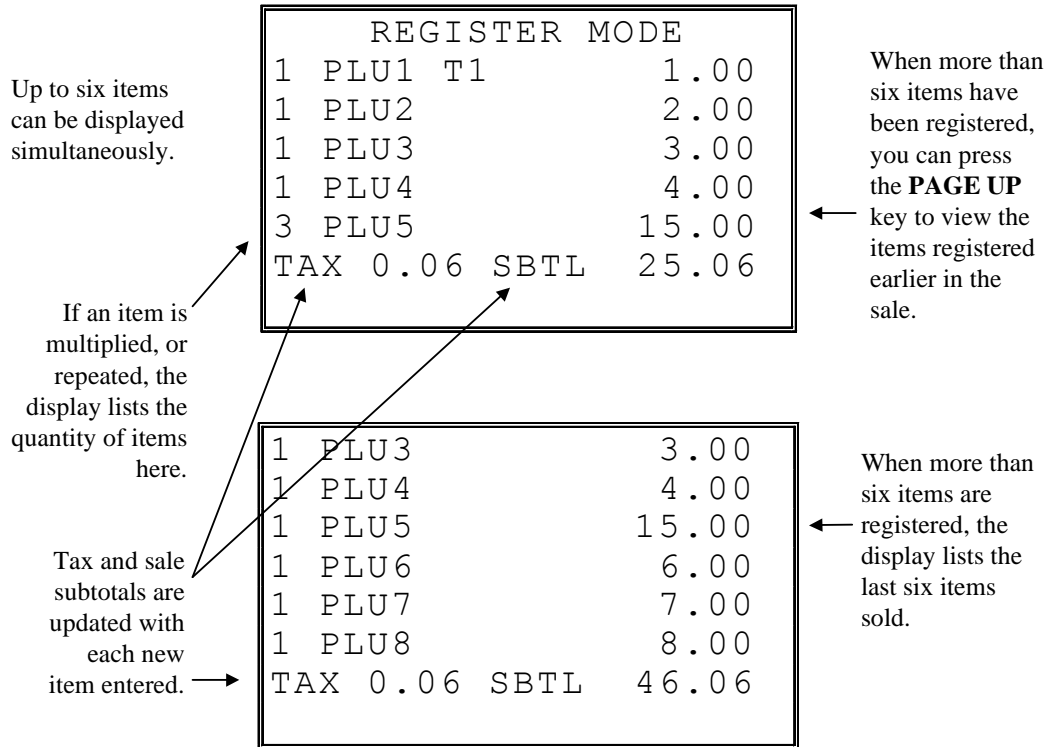

Clerk Operations

The number of clerks available is determined by memory allocation. See "Memory Allocation" in the "Service Mode Programming" chapter.

You can choose a push button or code entry clerk system:

- The simplest clerk system is the push button system. This is also the default system; the register will operate this way unless it is programmed otherwise. You simply press the **CLERK #** key to sign on or sign off the clerk. You can operate only one clerk per register when you choose this method.
- You can provide maximum security in a multiple clerk system with the code entry system. Enter the clerk secret code, then press the **CLERK #** key to sign on the register.
- You can sign off a clerk by entering **0**, then pressing the **CLERK #** key.

You can also select stay down or pop-up mode for clerk operation:

- Stay down means that once a clerk is signed on, the same clerk will remain signed on until the clerk signs off. A stay down clerk system might be used when only one operator uses the register at a time, and a different operator begins when a work shift is changed.
- Pop-up means that the clerk is automatically signed off at the end of each transaction. Therefore, to begin a transaction, you must first sign a clerk on. A pop-up clerk system might be used in a department store, where several clerks might use the register during the same shift and clerk sales information is required.

See "System Options" in the "Program Mode Programming" chapter to set clerk options.

Clerk Sign On Instructions

When a clerk is not signed on, the message "CLOSED" is shown on the display. The current clerk must be signed off before a new clerk can be signed on.

Push Button



Code Entry

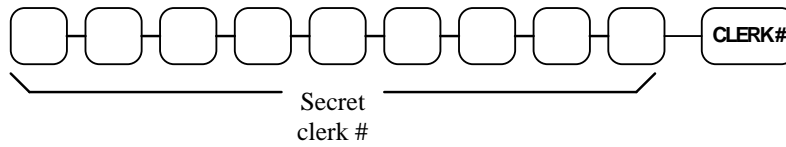

Clerk Sign Off Instructions

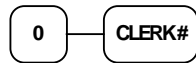

Clerk Time Keeping

Clerk time keeping is a standard feature of the *ER-650/650R*. Clerks can clock in and clock out at any time, regardless of whether they are signed on to operate the register. (Clocking in and clocking out are separate functions from signing on or signing off to operate the register.) You must assign secret clerk codes to clock in or clock out. See "System Options" in the "Program Mode Programming" chapter to set up your clerk system and see "Clerk Programming" to assign a secret code.

In addition:

- If a clerk forgets to sign in or sign out, or if sign in or out records need to be modified, these corrections can be made by the appropriate authority in the program mode. See "Clerk In/Out" in the "Program Mode Programming" chapter.
- Clerk times can be read in the **X** control lock position or reset in the **Z** control lock position. See the "X-Mode" and/or "Z-Mode" chapters.

Note: When a function is located on a function look up menu key, you access the function by pressing the appropriate function look up key, then pressing the numeric digit corresponding to the function you wish to select. On the default keyboard, the TIME IN/OUT function is function #8 on the function look up 1 menu, so to use the TIME IN/OUT function, you would first press FUNCTION LOOK#1, and then press the numeric 8 key.

To Clock In/Out:

1. Turn the control lock to the **REG** position.
2. Any current transaction must be finalized before clocking in or out.
3. Press the **TIME IN/OUT** key (or, select the TIME IN/OUT function from one of the function look up keys.)

TIME CLOCK IN/OUT
ENTER SECRET CODE
AND PRESS CASH

4. Enter the secret code of the clerk that is to clock in, press **ENTER (CASH)**. The display will show the 3 most recent in and out records for the clerk, and the total time worked.

```

TIME CLOCK IN/OUT
I 01/15/1999 08:00
O 01/15/1999 05:00
I 00/00/0000 00:00
O 00/00/0000 00:00
I 00/00/0000 00:00
O 00/00/0000 00:00
TIME WORKED: 09:00

```

5. Repeat the procedure from step 1 to clock out.
6. The printer will print Time In and Time Out records as in the examples below:

```

                THANK-YOU
                CALL AGAIN

DATE 08/15/1999 SUN   TIME 08:33

=====
CLERK TIME IN
=====

CLERK 1                01
IN :                   11/09/1999 08:33
CLERK 1                No.000011 00001

```

```

                THANK-YOU
                CALL AGAIN

DATE 08/15/1999 SUN   TIME 08:33

=====
CLERK TIME OUT
=====

CLERK 1                01
OUT :                   11/09/1999 08:33
CLERK 1                No.000011 00001

```

Item Registrations

All registrations are accumulated into PLUs. Keyboard PLUs are fixed keys on the keyboard (like traditional department keys) that access specific PLUs.

- On the default keyboard, there are 30 Keyboard PLU keys and the PLU# assigned to the key is the same, i.e. Keyboard PLU number one is PLU #1. However, through programming, you can assign any PLU number you wish to any one of the 69 possible Keyboard PLU keys.
- Traditional PLUs can also be registered by entering the PLU number and pressing the PLU key.
- If optional scanning is implemented, the PLU number corresponds to the UPC number and a PLU is registered when an item is scanned.

As you make item registrations, you can follow your entries by viewing the display. Remember that the sale and tax totals are updated automatically with each entry.

Using Function Look-Up Keys

Because the *ER-650/650R* keyboard is programmable, both the selection and location of function keys may vary from one register to another.

You must pay particular attention to the two function look-up keys, **FUNCTION LOOK-UP #1** and **FUNCTION LOOK-UP #2**. Each of these keys can contain a list of up to 8 functions that can be used as if they were located on separate keys. For example:

- If a function, such as **CHARGE1**, is located on a function look-up key, as it is on the default keyboard, then you must access it by pressing the appropriate function look-up key, then pressing the digit that represents the function, instead of pressing a key on the keyboard.
- If you need to make a numeric entry before a function that is located on a function look-up key, first press the numeric key or keys, then press the function look-up key and press the digit that represents the function you wish to select.

Open Keyboard PLU Entry

1. Enter an amount on the ten key pad. *Do not use the decimal key.* For example, for \$2.99, enter:

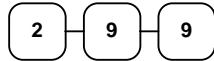

2. Press a PLU key. For example, press PLU 1:



THANK-YOU		
CALL AGAIN		
DATE	08/15/1999 SUN	TIME 08:33
PLU1 T1		\$2.99
TAX1		\$0.18
TOTAL		\$3.17
CASH		\$3.17
CLERK 1	No.000011	00001

Preset Price Keyboard PLU

A preset PLU registers the price that was previously programmed for the PLU. See "PLU Programming" in the "Program Mode Programming" chapter to program preset prices.

1. Press a preset PLU key. For example, press PLU 5:

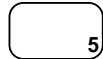

THANK-YOU		
CALL AGAIN		
DATE	08/15/1999 SUN	TIME 08:33
PLU5		\$1.29
TOTAL		\$1.29
CASH		\$1.29
CLERK 1	No.000011	00001

Keyboard PLU Repeat Entry

Open or preset price PLUs can be repeated as many times as necessary by pressing the same PLU again. The number of times the item is repeated is shown on the display.

1. Enter an amount on the ten key pad. Do not use the decimal key. For example, for \$2.99, enter:

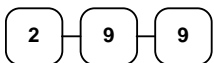

2. Press a PLU key. For example, press PLU 1:



3. To register a second item exactly as the first, press the PLU key a second time. For example, press PLU 1:

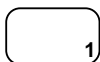

THANK-YOU		
CALL AGAIN		
DATE	08/15/1999 SUN	TIME 08:33
PLU1 T1		\$2.99
PLU1 T1		\$2.99
TAX1		\$0.36
TOTAL		\$6.34
CASH		\$6.34
CLERK 1	No.000011	00001

Keyboard PLU Multiplication

When several of the same items are to be entered into the same PLU, you can use multiplication. You can enter a quantity (1 to 999.999) using the **@/FOR** key. You can multiply open or preset PLUs.

1. Enter the quantity of items being purchased, press the **@/FOR** key. For example, enter **4** on the numeric key pad and press the **@/FOR** key:



2. Enter an amount on the ten key pad. Do not use the decimal key. For example, for \$1.99, enter:

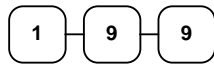

3. Press a PLU key. For example, press **PLU 1**:



THANK-YOU		
CALL AGAIN		
DATE	08/15/1999 SUN	TIME 08:33
4X	@1.99	
PLU1 T1		\$7.96
TAX1		\$0.48
TOTAL		\$8.44
CASH		\$8.44
CLERK 1	No.000011	00001

Keyboard PLU Multiplication with Decimal Point

If you are selling items by weight, or if you are selling yard goods, you can multiply a fraction of a unit.

1. Enter the amount with the decimal point, press the **@/FOR** key. For example, for 3.75 pounds of produce, enter:

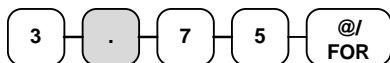

2. Enter an amount on the ten key pad. *Do not use the decimal key.* For example, if the price is \$.99 per pound, enter:



3. Press a PLU key. For example, press **PLU 1**:

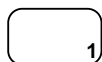

THANK-YOU CALL AGAIN		
DATE 08/15/1999 SUN	TIME 08:33	
3.75X	@0.99	
PLU1 T1		\$3.71
TAX1		\$0.22
TOTAL		\$3.93
CASH		\$3.93
CLERK 1	No.000011	00001

Split Pricing (Keyboard PLU)

When items are priced in groups, i.e. 3 for \$1.00, you can enter the quantity purchased and let the register calculate the correct price.

1. Enter the quantity purchased, press the **@/FOR** key. For example, enter:



2. Enter the quantity of the group price, press the **@/FOR** key. For example, if the items are priced 3 for \$1.00, enter:



3. Enter an amount on the ten key pad. For example, if the items are priced 3 for \$1.00, enter:

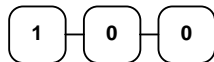

4. Press a PLU key. For example, press PLU 1:



THANK-YOU	
CALL AGAIN	
DATE 08/15/1999 SUN	TIME 08:33
2@3FOR	@1.00
PLU1 T1	\$0.67
TAX1	\$0.04
TOTAL	\$0.71
CASH	\$0.71
CLERK 1	No.000011 00001

Single Item Keyboard PLU

Single item PLUs automatically total as a cash sale immediately after registration. Use single item PLUs for speedy one item sales. For example if you are selling admission tickets, and all ticket sales are one item sales, you can use an open or preset PLU. After each registration, the drawer will immediately open, and a separate transaction receipt is printed. See "PLU Programming" in the "Program Mode Programming" chapter to program a single item PLU.

1. Press a single item preset PLU key. (or enter a price and press a single item open PLU key.) For example, press PLU **6**:



THANK-YOU		
CALL AGAIN		
DATE	08/15/1999 SUN	TIME 08:33
PLU6		\$1.29
TOTAL		\$1.29
CASH		\$1.29
CLERK 1	No.000011	00001

Open Code Entry PLU

If the PRESET status of a PLU is set to N (no), the PLU will operate as an open PLU. See "PLU Programming" in the "Program Mode Programming" chapter to program PLU descriptors and options.

1. Enter the PLU number; press the PLU key. For example, enter:



2. The display will prompt "ENTER PRICE". Enter an amount on the ten key pad. *Do not use the decimal key.* For example, for \$2.99, enter:

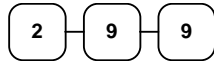

3. Press the PLU key again.



THANK-YOU		
CALL AGAIN		
DATE	08/15/1999 SUN	TIME 08:33
PLU2 T1		\$2.99
TAX1		\$0.18
TOTAL		\$3.17
CASH		\$3.17
CLERK 1	No.000011	00001

Preset Price Code Entry PLU

1. Enter the PLU number; press the PLU key. For example, enter:



THANK-YOU		
CALL AGAIN		
DATE	08/15/1999 SUN	TIME 08:33
PLU1		\$1.29
TOTAL		\$1.29
CASH		\$1.29
CLERK 1	No.000011	00001

Code Entry PLU Multiplication

When several of the same items are to be entered into the same PLU, you can use multiplication. You can enter a quantity (1 to 999.999) using the **@/FOR** key. You can multiply open or preset PLUs.

1. Enter the quantity of items being purchased, press the **@/FOR** key. For example, enter **4** on the numeric key pad and press the **@/FOR** key:



2. Enter the PLU number; press the **PLU** key. For example, enter:



THANK-YOU		
CALL AGAIN		
DATE	08/15/1999 SUN	TIME 08:33
4X	@1.99	
PLU1 T1		\$7.96
TAX1		\$0.48
TOTAL		\$8.44
CASH		\$8.44
CLERK 1	No.000011	00001

Code Entry PLU Multiplication with Decimal Point

If you are selling items by weight, or if you are selling yard goods, you can multiply a fraction of a unit.

1. Enter the quantity with the decimal point, press the **@/FOR** key. For example, for 3.75 pounds of produce, enter:

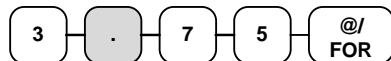

2. Enter the PLU number; press the **PLU** key. For example, enter:



THANK-YOU CALL AGAIN		
DATE 08/15/1999 SUN	TIME 08:33	
3.75X	@2.99	
PLU3 T1		\$11.21
TAX1		\$0.67
TOTAL		\$11.88
CASH		\$11.88
CLERK 1	No.000011	00001

Split Pricing Code Entry PLU

When items are priced in groups, i.e. 3 for \$1.00, you can enter the quantity purchased and let the register calculate the correct price.

1. Enter the quantity purchased, press the **@/FOR** key. For example, enter:



2. Enter the quantity of the group price, press the **@/FOR** key. For example, if the items are priced 3 for \$1.00, enter:



3. Enter the PLU number; press the **PLU** key. For example, enter:



THANK-YOU CALL AGAIN		
DATE 08/15/1999 SUN	TIME 08:33	
2@3FOR	@2.99	
PLU3 T1		\$1.99
TAX1		\$0.12
TOTAL		\$2.11
CASH		\$2.11
CLERK 1	No.000011	00001

PLU Price Inquiry

You can check the price of a PLU without registering the PLU by placing a price inquiry function key on the keyboard.

1. Press the **PRICE INQ** key. The message "PRICEINQ" displays:



2. Press a preset PLU key, or enter a PLU number and press the PLU key:

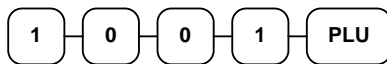

3. The PLU number and price display on the screen. If the PLU has prices at more than one price level, all prices will be shown.
4. Press **CLEAR** to remove the price information from the screen, or enter the PLU again to register the item.

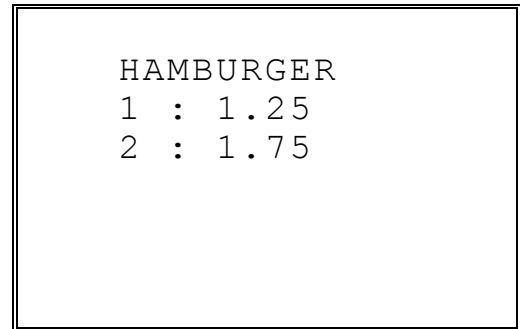

Modifier Key

Pressing a modifier key alters the next PLU registered, either by changing the code number of the PLU so that a different item is registered, or by just adding the modifier descriptor and registering the same PLU. See "Modifier 1-5" in the "Program Mode Programming" chapter in order to determine how the modifier key will affect the PLU entry.

Modifiers can be:

- *stay down* so that registrations will be modified by the same modifier until another modifier is selected,
- *pop-up after each item* to register, for example large, medium or small soft drink,
- *pop-up after each transaction* to register, for example, toppings of various pizza sizes.

See "System Options" in the "Program Mode Programming" chapter to select stay down/pop-up status.

Pop-Up Modifier Key Affecting PLU Code

1. Press a preset PLU key. For example, press PLU 1 with a price of \$1.00.

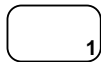

2. Press the **MOD 1** key. The message "MOD1" displays.

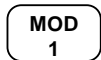

3. Press the same PLU key. In this example the modifier 1 will add the digit 1 to the fourth PLU # position, resulting in the registration of PLU #1001.



4. Press another PLU key. In this example press PLU 2 with a price of \$1.50.

THANK-YOU	
CALL AGAIN	
DATE 08/15/1999 SUN	TIME 08:33
PLU1	\$1.00
MOD1	
#1001	\$1.25
PLU2	\$1.50
TOTAL	\$3.75
CASH	\$3.75
CLERK 1	No.000011 00001

Price Level Key

If you choose to use the price level feature, you must allocate memory for each level. See "Memory Allocation" in the "Service Mode Programming" chapter. Note that the default program selects one price level. You must also place price level keys on the keyboard. See "Function Key Assignment" in the "Program Mode Programming" chapter.

If you use this feature, the same PLU can be given up to 5 different preset prices. Price Level keys shift the price that is being registered. Levels can be:

- *stay down* so that registrations will stay in the selected level until another level is selected,
- *pop-up after each item* to register, for example large, medium or small soft drink,
- *pop-up after each transaction* to register, for example, toppings of various pizza sizes.

See "System Options" in the "Program Mode Programming" chapter to set how the price level keys operate.

Pop-Up Price Level Keys

1. Press a preset PLU key. For example, press PLU 1 programmed with a price of \$1.00 for price level 1.



2. Press the **LEVEL 2** key. The message "LEVEL 2" displays.

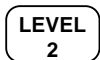

3. Press the same PLU key. In this example the PLU 1 key is programmed with a price of \$2.00 for price level 2.

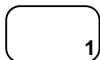

4. Press another PLU key. In this example press PLU 2 programmed to register PLU #2 with price level 1. Note that the level 1 price is registered.

THANK-YOU	
CALL AGAIN	
DATE 08/15/1999 SUN	TIME 08:33
PLU1	\$1.00
PLU1	\$2.00
PLU2	\$1.50
TOTAL	\$4.50
CASH	\$4.50
CLERK 1	No.000011 00001

Promo

The **PROMO** key allows you to account for promotional items, as in "buy two, get one free". Pressing this key will remove an item's cost from the sale, and the promo item will not be added to the PLU sales total, but it is added to the item sales counter. If stock (inventory) reporting is used, the item will be subtracted from inventory.

1. Register an item. For example, press **PLU 1** programmed with a price of \$1.00 for price level 1.

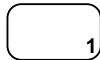

2. Press the **PROMO** key. The message "PROMO" displays.



3. Enter the item to be promo'd. You can not enter an item that has not been already registered in this transaction.



```
THANK-YOU
CALL AGAIN

DATE 08/15/1999 SUN   TIME 08:33

PLU1                $1.00
***PROMO***

PLU1
TOTAL                $0.00
CASH                 $0.00
CLERK 1             No.000011 00001
```

Waste

The **WASTE** key allows control of inventory by accounting for items that must be removed from stock due to spoilage, breakage or mistakes. Press the **WASTE** key before entering wasted items, and then press the **WASTE** key again to finalize. The **WASTE** key may be under manager control, requiring the control lock to be in the **X** position. The **WASTE** key is not allowed within a sale.

1. Press the **WASTE** key. The message "WASTE" displays at the top of the screen.

WASTE

2. Enter the item or items that are wasted.
3. Press the **WASTE** key again to total the wasted items:

WASTE

```
THANK-YOU
CALL AGAIN

DATE 08/15/1999 SUN   TIME 08:33

***WASTE***
PLU1                $1.25
PLU2                $1.50
***WASTE***
TOTAL                $2.75
CLERK 1             No.000011 00001
```

Shifting or Exempting Tax

Shifting Tax

PLUs can be programmed to automatically add the appropriate tax or taxes. Occasionally, you may need to sell a normally taxable item without tax, or a normally non-taxable item with tax. You can perform this tax shifting with one of the four tax shift keys.

1. Press the tax shift for the tax you wish to shift. For example, Press **TAX SHIFT 1**:



2. Enter an amount on the ten key pad. *Do not use the decimal key.* For example, for \$2.99, enter:

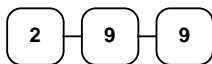

3. Press a PLU key. For example, press PLU 1. If PLU 1 is normally taxable by tax 1, the registration will be non-taxable.

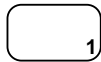

THANK-YOU	
CALL AGAIN	
DATE 08/15/1999 SUN	TIME 08:33
PLU1	\$2.99
TOTAL	\$2.99
CASH	\$2.99
CLERK 1	No.000011 00001

Exempting Tax

Occasionally, you may need to exempt tax from an entire sale. For example, you might remove all state and local taxes when you sell merchandise to a church or charitable institution.

You can exempt tax by using the tax shift keys and the **SUBTOTAL** key, or you can use the **TAX EXMT** (tax exempt) function key.

Exempting Tax with Tax Shift Keys

1. Enter an amount on the ten key pad. Do not use the decimal key. For example, for \$2.99, enter:

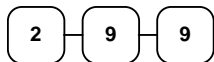

2. Press a taxable PLU key. For example, press **PLU 1**:



3. Press **SBTL**:



4. Press the tax shift key (or keys) that represents the tax you wish to shift. For example, to exempt tax 1 press **TAX SHIFT 1**, then press **SBTL**:



5. The display reflects the transaction without added taxes. Total the sale with **CASH**, **CHECK**, or a **CHARGE** function. The sale will not include tax 1.

THANK-YOU CALL AGAIN		
DATE	08/15/1999 SUN	TIME 08:33
PLU1 T1		\$2.99
TOTAL		\$2.99
CASH		\$2.99
CLERK 1	No.000011	00001

Exempting Tax with the Tax Exempt Key

You can program the **TAX EXMT** function to remove all or selected taxes.

Note: When a function is located on a function look up menu key, you access the function by pressing the appropriate function look up key, then pressing the numeric digit corresponding to the function you wish to select. On the default keyboard, the **TAX EXMT** function is function #6 on the function look up 1 menu, so to use the **TAX EXMT** function, you would first press **FUNCTION LOOK#1**, then press the numeric 6 key.

1. Enter an amount on the ten key pad. Do not use the decimal key. For example, for \$2.99, enter:

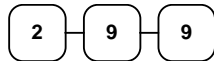

2. Press a taxable PLU key. For example, press **PLU 1**:

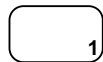

3. Press **SBTL**:



4. Press the **TAX EXMT** key (or access the **TAX EXMT** function from a function look up menu key):



5. The display reflects the transaction without added taxes. Total the sale with **CASH**, **CHECK**, or a **CHARGE** function. The sale will not include tax 1.

THANK-YOU	
CALL AGAIN	
DATE 08/15/1999 SUN	TIME 08:33
PLU1 T1	\$2.99
TOTAL	\$2.99
CASH	\$2.99
CLERK 1	No.000011 00001

Percent Key Operations

A total of five % functions are available. %1 and %2 are located on the default keyboard. Your keyboard may be different. More or less % keys may be located on the keyboard, or they may be located on one of the function look up menu keys.

Each function is individually programmable to add or subtract, from an individual item or from a sale total, amounts (coupons) or percentages. You can also program the percentage key taxable or non-taxable, so that sales taxes are calculated on the net, or the gross amount of the item or sale. You can also program preset prices or percentages.

The operation examples in this section show the percentage key in a variety of configurations. See "Function Key Programming" in the "Program Mode Programming" chapter to assign a specific function to each percentage key.

Preset Percent Discount on an Item

In this example the %1 function is preset with a rate of 10 %.

1. Register the item.
2. Press the %1 key:

% 1

3. The discount is automatically subtracted.

THANK-YOU	
CALL AGAIN	
DATE 08/15/1999 SUN	TIME 08:33
PLU2	\$10.00
% 1	-10.000%
AMOUNT	-1.00
TOTAL	\$9.00
CASH	\$9.00
CLERK 1	No.000011 00001

Enter a Percent Discount on an Item

You can also operate the percentage functions by entering the percentage of the discount or surcharge. If necessary, you can enter a fractional percentage up two 3 digits beyond the decimal (i.e. 99.999%).

1. Register the discounted item.
2. Enter the percentage. If you are entering a fraction of a percent, you must use the decimal key. For example, for one third off enter:



3. Press the %1 key:

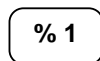

4. The discount is automatically subtracted.

THANK-YOU	
CALL AGAIN	
DATE 08/15/1999 SUN	TIME 08:33
PLU2	\$10.00
% 1	-33.333%
AMOUNT	-3.33
TOTAL	\$6.67
CASH	\$6.67
CLERK 1	No.000011 00001

Percent on Sale Total

The percent can be an open or preset amount. In this example an open percentage surcharge of 15% is applied.

1. Register the items you wish to sell.
 2. Press the **SBTL** key:
3. Enter the percentage, press the appropriate discount key. For example, for 15% enter:

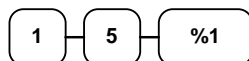

4. The surcharge is automatically added.

THANK-YOU	
CALL AGAIN	
DATE 08/15/1999 SUN	TIME 08:33
PLU2	\$10.00
% 1	15.000%
AMOUNT	\$1.50
TOTAL	\$11.50
CASH	\$11.50
CLERK 1	No.000011 00001

Coupon on Sale (Vendor Coupon)

When programmed as "amount", "sale", "open" and "negative", a % key will perform a coupon against a sale (or vendor coupon.) Also, depending upon programming:

- You may be allowed to enter only one coupon in a sale, after the **SBTL** key is pressed,
- You may be allowed to enter multiple coupons, but you must press the **SBTL** key before each coupon entry, or
- You may be allowed to enter multiple coupons, without first pressing **SBTL**.

In this example, a coupon may be entered only once, and you must first press **SBTL**.

1. Register the items you wish to sell.

2. Press the **SBTL** key:

SBTL

3. Enter the amount of the coupon, press the appropriate % key. For example:

2 0 0 % 1

4. The coupon is subtracted.

THANK-YOU CALL AGAIN		
DATE	08/15/1999 SUN	TIME 08:33
PLU2		\$10.00
%1		-2.00
TOTAL		\$8.00
CASH		\$8.00
CLERK 1	No.000011	00001

Coupon on Item (Store Coupon)

When programmed as "amount", "item", "open" and "negative", a % key will perform a coupon against an item (or store coupon.) In this case, you must press the PLU (or enter the PLU number) of the PLU you wish the coupon to be subtracted from.

1. Register the items you wish to sell.
2. Enter the amount of the coupon, press the appropriate % key. For example:

2 0 0 % 1

3. Press the PLU key you wish to subtract the coupon from (or enter the PLU number of the PLU you wish to subtract the coupon from and press **PLU**.)

1

4. The coupon is automatically subtracted.

THANK-YOU	
CALL AGAIN	
DATE 08/15/1999 SUN	TIME 08:33
PLU1	\$10.00
PLU1 C	-2.00
TOTAL	\$8.00
CASH	\$8.00
CLERK 1	No.000011 00001

Return Merchandise Registrations

If you wish to return or refund an item, press **MDSE RETURN**, then re-enter any item. You can return merchandise as part of a sale, or you can return merchandise as a separate transaction and return cash to the customer.

Note: When a function is located on a function look up menu key, you access the function by pressing the appropriate function look up key, then pressing the numeric digit corresponding to the function you wish to select. On the default keyboard, the MDSE RETURN function is function #2 on the function look up 1 menu, so to use the MDSE RETURN function, you would first press FUNCTION LOOK#1, then press the numeric 2 key.

1. Press **MDSE RETURN**:



2. Enter the price of the item you wish to return, then press the PLU key where it was registered originally.

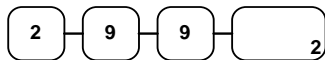

3. Total the sale with **CASH**, **CHECK**, or a **CHARGE** function.

THANK-YOU	
CALL AGAIN	
DATE 08/15/1999 SUN	TIME 08:33
RETURN *****	
PLU2 T1	-2.99
TAX1 AMT	-0.18
TOTAL	-3.17
CASH	-3.17
CLERK 1	No.000011 00001

Voids and Corrections

Error Correction (Void Last Item)

This function corrects the last item entered.

1. Register the item you wish to sell.
2. Press the **ERROR CORR** key:



THANK-YOU	
CALL AGAIN	
DATE 08/15/1999 SUN	TIME 08:33
PLU1 T1	\$2.29
PLU2	\$1.29
ERR CORR -----	
PLU2	-1.29
TAX1 AMT	\$0.14
TOTAL	\$2.43
CASH	\$2.43
CLERK 1	No.000011 00001

Void Previous Item

This function allows you to correct an item registered previously in a transaction.

1. Register an item. Then register a second item.
2. To correct the first item, press **VOID ITEM**:

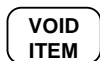

3. Enter the price of the first item, then press the PLU key where it was registered originally.

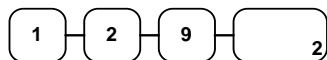

THANK-YOU	
CALL AGAIN	
DATE 08/15/1999 SUN	TIME 08:33
PLU2	\$1.29
PLU1 T1	\$2.29
VOID -----	
PLU2	-1.29
TAX1 AMT	\$0.14
TOTAL	\$2.43
CASH	\$2.43
CLERK 1	No.000011 00001

Cancel

The **CANCEL** key allows you to stop any transaction. Anything registered within the transaction before the **CANCEL** key is pressed is automatically corrected. The **CANCEL** key can be inactivated through programming, see "Function Key Programming" in the "Program Mode Programming" chapter, or the key can be programmed to require manager control.

Note: When a function is located on a function look up menu key, you access the function by pressing the appropriate function look up key, then pressing the numeric digit corresponding to the function you wish to select. On the default keyboard, the **CANCEL** function is function #1 on the function look up 1 menu, so to use the **CANCEL** function, you would first press **FUNCTION LOOK#1**, then press the numeric 1 key.

1. Register the items you wish to sell.
2. Press the **CANCEL** key (or access the **CANCEL** function from the function look up menu.)

CANCEL

```
THANK-YOU
CALL AGAIN

DATE 08/15/1999 SUN   TIME 08:33

PLU1 T1                $2.29
PLU2                   -0.50
CANCEL *****
CLERK 1                No.000011  00001
```

Void Position Operations

You can use the **VOID** control lock position to correct any complete transaction. To correct any transaction:

1. Turn the control lock to the **VOID** position.
2. Enter the transaction you wish to correct exactly as it was entered originally in the **REG** control lock position. You can enter discounts, voids, returns, tax exemptions or any other function.
3. All totals and counters are corrected as if the original transaction did not take place.

```
THANK-YOU
CALL AGAIN

DATE 08/15/1999 SUN   TIME 08:33

VOID MODE *****
PLU1 T1                -2.29
PLU2                   -1.00
TAX1 AMT               -0.14
TOTAL                  -3.43
CASH                   -3.43
CLERK 1                No.000011  00001
```

No Sale Operations

Open Drawer

The **#/NO SALE** key will open the cash drawer when you have not already started a transaction. The no sale function can be disabled or placed under manager control through programming, see "Function Key Programming" in the "Program Mode Programming" chapter.

1. Press **#/NS**:

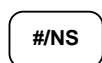

2. The drawer will open and the receipt will print as in the example on the right.

```
THANK-YOU
CALL AGAIN

DATE 08/15/1999 SUN   TIME 08:33

NO SALE -----
CLERK 1           No.000011  00001
```

Non Add Number

You can also use the **#/NO SALE** key to print any number (up to 9 digits) on the printer paper. You can enter the number any time during a transaction. For example, if you wish to record a checking account number, enter the number and press the **#/NO SALE** key before totaling the sale with the **CHECK** key.

1. Register the items you wish to sell.
2. Enter the number you wish to record, for example enter:



3. Press **#/NS**:

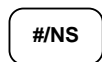

4. Press **CHECK**:



```
THANK-YOU
CALL AGAIN

DATE 08/15/1999 SUN   TIME 08:33

PLU1 T1                $2.99
NON-ADD#                1234
TAX1 AMT                $0.18
TOTAL                  $3.17
CHECK                  $3.17
CLERK 1           No.000011  00001
```

Received On Account Operations

You can use one of the received on account functions (**RA1-RA3**) to accept cash or checks into the cash drawer when you are not actually selling merchandise. For example, use received on account to accept payments for previously sold merchandise, or record loans to the cash drawer.

Note: When a function is located on a function look up menu key, you access the function by pressing the appropriate function look up key, then pressing the numeric digit corresponding to the function you wish to select. On the default keyboard, the RA1 function is function #3 on the function look up 1 menu, so to use the RA1 function, you would first press FUNCTION LOOK#1, then press the numeric 3 key.

1. Press one of the received on account keys (**RA1-RA3**) or select one of the received on account functions from a function look up menu:



2. Enter the amount of cash received, press **CASH**.

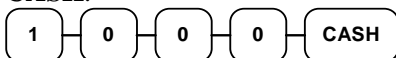

3. Enter the check amount received, press **CHECK**.

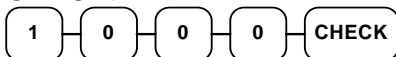

4. Enter the charge amount received, press **CHARGE1**, (or press the **FUNCTION LOOKUP** key and press the numeric key representing the appropriate charge function.)

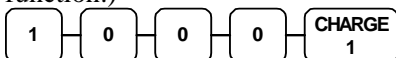

5. You can continue to itemize receipts, or you can finalize by pressing or selecting the same received on account key.



THANK-YOU CALL AGAIN		
DATE	08/15/1999 SUN	TIME 08:33
RA1		
CASH		\$10.00
CHECK		\$10.00
CHARGE1		\$10.00
RA1		\$30.00
CLERK 1	No.000011	00001

Paid Out Operations

You can use the **PAID OUT** function to track cash or checks paid out or to record loans from the cash drawer.

Note: When a function is located on a function look up menu key, you access the function by pressing the appropriate function look up key, then pressing the numeric digit corresponding to the function you wish to select. On the default keyboard, the PO1 function is function #4 on the function look up 1 menu, so to use the PO1 function, you would first press **FUNCTION LOOK#1**, then press the numeric 4 key.

1. Press one of the paid out keys (**PO1-PO3**) or select one of the paid out functions from a function look up menu:

PO1

2. Enter the amount of cash paid out, press **CASH**.

1 0 0 0 CASH

3. Enter the check amount paid out, press **CHECK**.

1 0 0 0 CHECK

4. Enter the charge amount received, press **CHARGE1**, (or press the **FUNCTION LOOKUP** key and press the numeric key representing the appropriate charge function.)

1 0 0 0 CHARGE 1

5. You can continue to itemize paid outs, or you can finalize by pressing or selecting the same paid out key.

PO1

THANK-YOU	
CALL AGAIN	
DATE 08/15/1999 SUN	TIME 08:33
PO1	
CASH	-10.00
CHECK	-10.00
CHARGE1	-10.00
PO1	-30.00
CLERK 1	No.000011 00001

Subtotaling a Sale

1. Register the items you wish to sell.
2. Press **SBTL**. The subtotal will display with the message "Sub" indicated on the rear display.



The subtotal can be printed if the system option is set. See "Print Option Programming" in the "Program Mode Programming" chapter.

Eat In/Take Out/Drive Thru Sales

Different types of sales, such as "Eat In", "Take Out" and "Drive Thru" can be categorized by placing separate keys on the keyboard. **EAT IN**, **TAKE OUT**, and **DRIVE THRU** keys function as subtotal keys. You can force the operator to press one of the keys before tendering. See "System Option Programming" in the "Program Mode Programming" chapter. Separate totals will be maintained on the financial report to detail sales counts and amounts for each key.

Totaling and Tendering

There are ten tender functions available to categorize sales. **CASH** and **CHECK** are individual keys on the keyboard. The eight charge functions **CHARGE 1 - CHARGE 8** are available on the **FUNCTION LOOK#2** key on the default keyboard.

Depending upon how your register is programmed you might find charge keys as individual function keys on the keyboard, or listed on one of the function look up keys.

Totaling a Cash Sale

1. Register the items you wish to sell.
2. To total a cash sale, press **CASH**:

CASH
ENTER

3. The display will indicate the total amount of the cash sale.

THANK-YOU	
CALL AGAIN	
DATE 08/15/1999 SUN	TIME 08:33
PLU2	\$7.96
TOTAL	\$7.96
CASH	\$7.96
CLERK 1	No.000011 00001

Totaling a Check Sale

1. Register the items you wish to sell.
2. To total a cash sale, press **CHECK**:

CHECK

3. The display will indicate the total amount of the cash sale.

THANK-YOU	
CALL AGAIN	
DATE 08/15/1999 SUN	TIME 08:33
PLU2	\$7.96
TOTAL	\$7.96
CHECK	\$7.96
CLERK 1	No.000011 00001

Tendering a Cash Sale

1. Register the items you wish to sell.
2. Enter the amount tendered by the customer. For example, for \$20.00 enter:



3. Press **CASH**:



4. The display will indicate the total amount of the cash tendered and the change due, if any.

THANK-YOU	
CALL AGAIN	
DATE 08/15/1999 SUN	TIME 08:33
PLU1 T1	\$2.99
PLU1 T1	\$2.99
4X	\$1.99
PLU2	\$7.96
TAX1	\$0.36
TOTAL	\$14.30
CASH	\$20.00
CHANGE	\$5.70
CLERK 1	No.000011 00001

Tendering a Check Sale

1. Register the items you wish to sell.
2. Enter the amount tendered by the customer. For example, for \$20.00 enter:



3. Press **CHECK**:

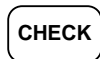

4. The display will indicate the total amount of the check tendered and the change due, if any.

THANK-YOU	
CALL AGAIN	
DATE 08/15/1999 SUN	TIME 08:33
PLU1 T1	\$2.99
PLU1 T1	\$2.99
4X	\$1.99
PLU2	\$7.96
TAX1	\$0.36
TOTAL	\$14.30
CHECK	\$20.00
CHANGE	\$5.70
CLERK 1	No.000011 00001

Totaling a Charge Sale

Use the charge keys to track charge or credit card sales. See "Function Key Programming" in the "Program Mode Programming" chapter to change the descriptors for the charge tender functions. For example, you can use CHARGE 1 to track Visa card sales. The descriptor "VISA" will display on the function look up menu and print on the printer. You can also set tendering options for the charge keys, i.e. whether to allow over tendering or to enforce tendering.

Note: When a function is located on a function look up menu key, you access the function by pressing the appropriate function look up key, then pressing the numeric digit corresponding to the function you wish to select. On the default keyboard, the **CHARGE 1** function is function #1 on the function look up 2 menu, so to use the **CHARGE 1** function, you would first press **FUNCTION LOOK#2**, then press the numeric **1** key.

1. Register the items you wish to sell.
2. Press one of the charge key if it is located on the keyboard:



or, if the charge function is located on a function look up key press **FUNCTION LOOK2**, then press the digit representing the charge function you are using:

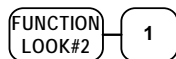

THANK-YOU CALL AGAIN		
DATE	08/15/1999 SUN	TIME 08:33
PLU1 T1		\$2.99
PLU1 T1		\$2.99
4X	\$1.99	
PLU2		\$7.96
TAX1		\$0.36
TOTAL		\$14.30
CHARGE1		\$14.30
CLERK 1	No.000011	00001

Tendering a Charge Sale

Tendering a charge sale may or may not be allowed. See "Function Key Programming" in the "Program Mode Programming" chapter to set tendering options for the charge keys, i.e. whether to allow over tendering or to enforce tendering.

1. Register the items you wish to sell.
2. Enter the amount of the charge and press one of the charge keys if it is located on the keyboard:

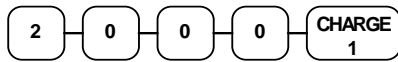

or, if the charge function is located on a function look up key, enter the amount of the charge:



Press **FUNCTION LOOK2**, then press the digit representing the charge function you are using:



THANK-YOU CALL AGAIN		
DATE	08/15/1999 SUN	TIME 08:33
PLU1 T1		\$2.99
PLU1 T1		\$2.99
4X	\$1.99	
PLU2		\$7.96
TAX1		\$0.36
TOTAL		\$14.30
CHARGE1		\$20.00
CHANGE		\$5.70
CLERK 1	No.000011	00001

Check Cashing

Check cashing means exchanging cash for a check. If you wish to cash checks, you must place a **CHKCASH** key on the keyboard. See "Function Key Assignment" in the "Program Mode Programming" chapter.

1. Enter the amount of the check tendered by the customer. For example, for \$20.00 enter:



2. Press **CHKCASH**:



3. The display will indicate the amount of the check and the cash change.

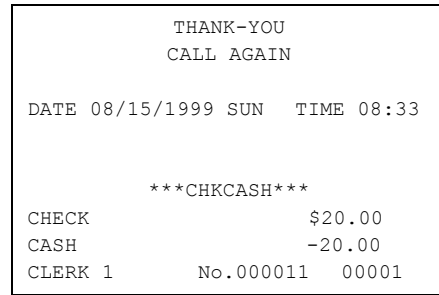

Split Tender

Split tendering is paying for one transaction by more than one payment method. For example, a \$20.00 sale could be split so \$10.00 is paid in cash, and the remaining \$10.00 is paid by a check. If necessary, you can make several different payments.

Note: The CASH and/or CHECK keys must be programmed to accept under tenders to use this feature.

1. Register the items you wish to sell.
2. Enter the amount of cash tendered by the customer. For example, enter \$10.00 and press **CASH**:

1 0 0 0 CASH
ENTER

3. The display will indicate the \$10.00 cash tender and the \$10.00 total still due.
4. Enter the amount of check tendered by the customer. For example, enter \$10.00 and press **CHECK**:

1 0 0 0 CHECK

5. When the total tendered equals or exceeds the total due, the receipt will print and the transaction is complete.

THANK-YOU	
CALL AGAIN	
DATE 08/15/1999 SUN	TIME 08:33
PLU2	\$20 00
TOTAL	\$20.00
CASH	\$10.00
TOTAL	\$10.00
CHECK	\$10.00
CLERK 1	No.000011 00001

Post Tender

Post tendering means computing change after the sale has been totaled and the drawer is open. This feature is useful when a customer changes the amount of the tender or when a "quick change artist" confuses a clerk. Normally, this function is not allowed. If you wish to allow post tendering, you must set the appropriate system option. See "System Option Programming" in the "Program Mode Programming" chapter. (A separate system option determines whether the drawer opens on the post tender.)

1. Register the items you wish to sell.
2. Press **CASH**:

CASH
ENTER

3. The display will indicate the total of the cash sale.
4. Enter the amount of the new tender,
Press **CASH**:

2 0 0 0 **CASH**
ENTER

5. The display will indicate the change due.

THANK-YOU	
CALL AGAIN	
DATE 08/15/1999 SUN	TIME 08:33
PLU1 T1	\$2.00
TAX1	\$0.12
CASH	\$2.12
CLERK 1	No.000011 00001

Food Stamp Sales

The *ER-650/650R* is capable of sorting food stamp and non-food stamp eligible items. Then if a customer chooses to pay by food stamps, the eligible total can be recalled and food stamp payments accepted.

If you choose to use this feature, you must:

- Locate the appropriate function keys on the keyboard, **F/S SHIFT**, **F/S SUB**, and **F/S TEND**, and then set the appropriate options for the **F/S TEND** key.
- Determine and set the food stamp status for each PLU item or category.

Refer to the "Service Mode Programming" and the "Program Mode Programming" chapters to make the appropriate settings.

1. Register the items you wish to sell. You do not need to sort food stamp eligible or non-eligible items. The *ER-650/650R* will maintain a subtotal of eligible items based upon the pre-programmed status for each PLU.

If you wish to register a normally food stamp eligible item into a PLU programmed as non-food stamp eligible, press the **F/S SHIFT** key before registering the item. In the same manner, you can register non-food stamp items into food stamp eligible PLUs.

THANK-YOU	
CALL AGAIN	
DATE 08/15/1999 SUN	TIME 08:33
PLU1 F	\$1.29
PLU2	\$4.29
TOTAL	\$5.58
F/S TOTAL	\$1.29
F/S TEND	\$20.00
F/S CRT AMT	\$0.71
TOTAL	\$3.58
CASH	\$5.00
CHANGE	\$1.42
F/S/ CHANGE	\$18.00
CLERK 1	No.000011 00001

2. If a customer wishes to pay with food stamps, press the **F/S SUB** key to display the food stamp eligible total:

F/S SUB

3. Enter the amount of food stamps tendered by the customer. For example, for \$20.00 enter:

2 0 0 0 **F/S TEND**

4. The remaining amount due displays. (Note, depending upon programming, change less than \$1 can be applied to the balance.)
5. Total or tender the remaining balance.

Currency Conversion

If you normally accept currency from neighboring nations, you can program the *ER-650/650R* to convert the subtotal of a sale to the equivalent cost in the foreign currency. You can set up four separate conversion functions for different foreign currencies. To do this, you need to program the conversion factor. For example, if the US dollar (home currency) is worth 1.3720 Canadian dollars (foreign currency), the conversion factor is 1.3720. See "Function Key Programming" in the "Program Mode Programming" chapter to set a conversion factor.

Note: When a function is located on a function look up menu key, you access the function by pressing the appropriate function look up key, then pressing the numeric digit corresponding to the function you wish to select. On the default keyboard, the CONV1 function is function #7 on the function look up 1 menu, so to use the CONV1 function, you would first press FUNCTION LOOK#1, then press the numeric 7 key.

1. Register the items you wish to sell.
2. Press the **CONV1** key if it is located on the keyboard:



or, if the conversion is located on a function look up key press **FUNCTION LOOK2**, then press the digit representing the **CONV1** function:

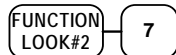

3. The amount due in foreign currency is displayed.
4. Enter the amount of the foreign currency tender, Press **CASH**:

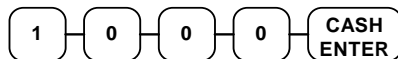

5. The display will indicate the amount of foreign currency tendered and display \$5.17 change due. **The change due is computed in home currency!**

THANK-YOU CALL AGAIN	
DATE 08/15/1999 SUN	TIME 08:33
PLU1 T1	\$2.00
TAX1	\$0.12
TOTAL	\$2.12
CONV 1	¥2.90
CHANGE RATE	@1.3720
HOME AMT.	\$10.00
CHANGE	\$5.17
CLERK 1	No.000011 00001

The currency symbol you program will display here. See "Print Option Programming" in the "Program Mode Programming" chapter.

Receipt On/Off and Receipt on Request

When a receipt is not normally issued, you can turn the receipt function off. See "Stop Register Printing" in the "X-Mode" chapter.

If the receipt is off, you can still issue a receipt after the sale has been completed.

Printing a Receipt after the Sale

- ◆ After the sale has been totaled, but before the next transaction is started, press **CASH:**



Check Tracking Operations

Important Note: Check tracking operations must take place on the same register. If an IRC register system is implemented, you cannot access the same checks from any register within the system. You must open, add to, and/or pay the check at the same register.

Overview

The *ER-650/650R* can employ a manual previous balance, hard check, or soft check system. (You must select hard or soft check posting in memory allocation programming - the default selection is soft.)

- If manual previous balance is selected, the check balance is not saved in memory and is input manually by the operator (use the **PBAL** key).
- If a hard check system is selected, only the previous balance is maintained in memory.
- If a soft check system is selected, the check detail is kept in memory until the check is paid. (The maximum size of the soft check is set in memory allocation programming.)

Options

For hard or soft check operations, the following tracking options are available:

- Tracking by manually entering the check number. (The number of digits in the check number may be set from 0-9, with zero meaning no fixed length.)
- Tracking by automatically assigning a check number. The starting check is always #1.
- Enforcing entry of a table number, where a check number is also assigned, allows the check balance to be recalled by either the check or table number. Multiple checks may be assigned at the same table. (If there are multiple checks assigned to the same table, an attempt to recall by table number will recall the check with the lowest number.)
- The check number can be scanned from a printed bar code. For example, a bar code can be printed on a customer identification badge.

For soft check operations, the following option is available:

- Consolidation of like items can be selected for guest check printing. For example, if three rounds of drinks are served, the check will print "3 TAP BEER" rather than "1 TAP BEER" three times.

Function Keys

Although none of the functions necessary for check tracking operations appear on the default keyboard, any or all of the following functions can be located on the keyboard:

CHECK #	<p>The CHECK # key is used to begin a new, or access an existing balance (hard check) or itemized bill (soft check.)</p> <p>Check track numbers that are entered manually may be set at a fixed length of one to nine digits. Check track numbers assigned automatically will begin with #1.</p> <p>Existing checks are accessed by entering the check track number and pressing the CHECK# key. In a drive thru system, simply pressing the PBAL key will recall the oldest open balance (lowest check track #).</p>
GUEST	<p>Use to enter the count of guests served as part of a guest check. The entry of a guest count can be enforced when opening a guest check, or for all transactions.</p>
P/BAL	<p>Use to enter the amount of an outstanding balance. The P/BAL key will take the recall function if the <i>drive thru</i> feature is enabled in CHECK # key programming.</p>
SERVICE	<p>Use to temporarily finalize Previous Balance or check tracking transactions. (If you are using a hard check system, you must program the SERVICE key for the port where the slip printer is connected.)</p>
TABLE	<p>You can enforce the entry of a table number for guest check transactions, or for all transactions. If you are tracking guest check balances, the balance can be recalled either by entering the check number or the table number.</p>
PRINT CHECK	<p>Use to print a guest check. The check can be printed on an optional (RS-232C) printer, or can be printed on the receipt printer. The PRINT CHECK key can be set to automatically service the check.</p>
TIP	<p>The TIP key allows a gratuity to be added to a guest check before payment. The tip amount is deducted from the Cash-in-Drawer amount for the Clerk/Cashier closing the guest check.</p> <p>The TIP key may be programmed as either a percentage or amount. If programmed as a percentage, tax programming defines whether the percentage is calculated on the net (taxable = no) amount, or the amount after taxes.</p>

See "Function Key Assignment" in the "Service Mode Programming" chapter to place the functions necessary for your application. See "Function Key Programming" in the "Program Mode Programming" chapter to set the options for each function.

Posting Balances Manually

Opening a Check

1. Enter the previous balance (if this is the first posting, enter **0**) press the **PBAL** key:



2. Register the items you wish to sell.
3. To total the posting, press **SERVICE**:



4. Place a slip in an optional slip printer, press the **PRINT CHECK** key.

THANK-YOU	
CALL AGAIN	
DATE 08/15/1999 SUN	TIME 08:33
PBAL	\$0.00
PLU2	\$1.00
SERVICE	\$1.00
BFWD	\$1.00
CLERK 1	No.000011 00001

Adding to a Check

1. Enter the previous balance, press the **PBAL** key:



2. Register the next items you wish to sell.
3. To total the posting, press **SERVICE**:



4. Place a slip in an optional slip printer, press the **PRINT CHECK** key.

THANK-YOU	
CALL AGAIN	
DATE 08/15/1999 SUN	TIME 08:33
PBAL	\$1.00
PLU3	\$2.00
SERVICE	\$2.00
BFWD	\$3.00
CLERK 1	No.000012 00001

Paying a Manual Balance

1. Enter the previous balance, press the **PBAL** key:

3 0 0 PBAL

2. If necessary, add additional items. If you wish to add a tip, press **SBTL**, then enter the tip amount and press the **TIP** key:

SBTL

5 0 TIP

3. Pay the balance as you would normally tender a transaction, with **CASH**, **CHECK**, or one of the **CHARGE** functions. If the tender is greater than the balance due, change is displayed:

1 0 0 0 CASH
ENTER

4. Place a slip in an optional slip printer, press the **PRINT CHECK** key.

THANK-YOU	
CALL AGAIN	
DATE 08/15/1999 SUN	TIME 08:33
PBAL	\$3.00
TIP	\$0.50
CHECKS PAID	\$3.50
CASH	\$10.00
CHANGE	\$6.50
CLERK 1	No.000013 00001

Soft Check

Opening a Soft Check

1. Enter the number of the guest check, press the **CHECK #** key:

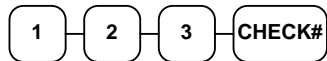

or, press the **CHECK #** key to automatically assign a check:



2. If required, enter the table number and press the **TABLE** key:



3. If required, enter the number of guests and press the **GUEST** key:



4. Register the items you wish to sell.
5. To total the posting, press **SERVICE**:



Receipt Example:

THANK-YOU CALL AGAIN	
DATE 08/15/1999 SUN	TIME 08:33
CHECK #	# 1 2 3
PBAL	\$0.00
TABLE	#3
GUEST	#2
CHICKEN	\$7.00
STEAK	\$10.00
SERVICE	\$17.00
BFWD	\$17.00
CLERK 1	No.000011 00001

Note: If a table number entry is required for all guest checks, and checks are assigned by register, the check will be assigned by the register when the table # is entered.

Adding to a Soft Check

1. Enter the number of the guest check, press the **CHECK #** key:

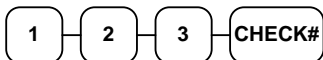

or, if you entered a table number, enter the table number and press the **TABLE** key:



2. Register the next items you wish to sell.
3. To total the posting, press **SERVICE**:



Printing a Soft Check

1. Enter the number of the guest check, press the **CHECK #** key:

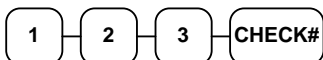

or, if you entered a table number, enter the table number and press the **TABLE** key:



2. Press **PRINT CHECK** to print the complete check. If programmed to do so, the **PRINT CHECK** key will automatically service the check:



Receipt Example:

THANK-YOU CALL AGAIN	
DATE 08/15/1999 SUN	TIME 08:33
CHECK #	#123
PBAL	\$17.00
TABLE	#3
GARLIC BREAD	\$2.00
SERVICE	\$2.00
BFWD	\$19.00
CLERK 1	No.000012 00001

Sample of soft check printed on the receipt:

THANK-YOU CALL AGAIN	
DATE 08/15/1999 SUN	TIME 08:33
CHECK #	#123
PBAL	\$19.00
TABLE	#3
CHICKEN	\$7.00
STEAK	\$10.00
GARLIC BREAD	\$2.00
SERVICE	\$0.00
BFWD	\$19.00
	CHK # : 1
CLERK 1	No.000012 00001

The number of times each check has been printed is counted and printed on the check

Paying a Soft Check

1. Enter the number of the guest check, press the **CHECK #** key:

1 — 2 — 3 — CHECK#

or, if you entered a table number, enter the table number and press the **TABLE** key:

3 — TABLE

2. If necessary, add additional items. If you wish to add a tip, press **SBTL**, then enter the tip amount and press the **TIP** key:

SBTL

3 — 0 — 0 — TIP

3. Pay the balance as you would normally tender a transaction, with **CASH**, **CHECK**, or one of the **CHARGE** functions. If the tender is greater than the balance due, change is displayed.

2 — 5 — 0 — 0 — CASH ENTER

Sample of soft check printed on the receipt:

THANK-YOU CALL AGAIN	
DATE 08/15/1999 SUN	TIME 08:33
CHECK #	# 1 2 3
PBAL	\$19.00
TABLE	#3
TIP	\$3.00
CHECKS PAID	\$22.00
CASH	\$25.00
CHANGE	\$3.00
	CHK # : 2
CLERK 1	No.000013 00001

Hard Check

Opening a Hard Check

1. Enter the number of the guest check, press the **CHECK #** key:

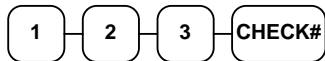

or, press the **CHECK #** key to automatically assign a check:



2. If required, enter the table number and press the **TABLE** key:



3. If required, enter the number of guests and press the **GUEST** key:

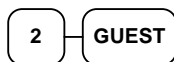

4. Register the items you wish to sell.
5. Place a slip in an optional slip printer, the check will print automatically when you press **SERVICE**:



Receipt Example:

THANK-YOU CALL AGAIN	
DATE 08/15/1999 SUN	TIME 08:33
CHECK #	#123
PBAL	\$0.00
TABLE	#3
GUEST	#2
CHICKEN	\$7.00
STEAK	\$10.00
SERVICE	\$17.00
BFWD	\$17.00
CLERK 1	No.000011 00001

Adding to a Hard Check

1. Enter the number of the guest check, press the **CHECK #** key:

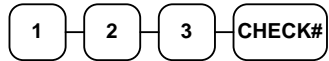

or, if you entered a table number, enter the table number and press the **TABLE** key:



2. Register the next items you wish to sell.
3. To total the posting, press **SERVICE**:



Receipt Example:

THANK-YOU CALL AGAIN	
DATE 08/15/1999 SUN	TIME 08:33
CHECK #	#123
PBAL	\$17.00
TABLE	#3
GARLIC BREAD	\$2.00
SERVICE	\$2.00
BFWD	\$19.00
CLERK 1	No.000012 00001

Paying a Hard Check

1. Enter the number of the guest check, press the **CHECK #** key:

1 2 3 CHECK#

or, if you entered a table number, enter the table number and press the **TABLE** key:

3 TABLE

2. If necessary, add additional items. If you wish to add a tip, press **SBTL**, then enter the tip amount and press the **TIP** key:

SBTL

3 0 0 TIP

3. Pay the balance as you would normally tender a transaction, with **CASH**, **CHECK**, or one of the **CHARGE** functions. If the tender is greater than the balance due, change is displayed.

2 5 0 0 CASH ENTER

Sample of Hard Check postings printed on an optional printer:

DATE	12/01/1999	WED
CHECK #		#4
PBAL		\$0.00
STEAK T1		\$15.50
LOBSTER T1		\$19.50
WINE T1		\$2.50
WINE T1		\$2.50
TAX1		\$3.60
SERVICE		\$43.60
BFWD		43.60
No.000017 REG 01 ETHAN		TIME 09:15
PBAL		\$43.60
2X	@2.50	
WINE T1		\$5.00
TAX1		\$4.05
SERVICE		\$5.45
BFWD		49.05
No.000019 REG 01 ETHAN		TIME 09:47
PBAL		\$49.05
2X	@2.50	
WINE T1		\$5.00
TAX1		\$4.50
CHECKS PAID		\$54.50
TOTAL		\$54.50
CASH		\$54.50
No.000021 REG 01 ETHAN		TIME 10:16

Fast Food Drive Thru

For fast food drive thru windows, the *ER-650/650R* has the capability of storing orders when they are taken, and then recalling the next order automatically at the payment window.

- The **PBAL** function becomes a recall function when the drive thru feature is enabled in the **CHECK #** function key program. Press the **PBAL** key to recall the lowest tracking number balance.
- Orders are stored by first pressing the **CHECK #** key to automatically assign the next tracking number, then pressing **SERVICE**. (A macro sequence key could be created to execute both functions sequentially by pressing the **MACRO** key.)

See "Function Key Programming" in the "Program Mode Programming" chapter.

Taking a Drive Thru Order

1. Register the items you wish to sell.
2. Press the **CHECK #** key to begin an automatically assigned check:

CHECK#

3. To store the posting, press **SERVICE**:

SERVICE

Receipt Example:

THANK-YOU	
CALL AGAIN	
DATE 08/15/1999 SUN	TIME 08:33
HAMBURGER	\$2.00
FRIES	\$1.00
CHECK #	# 3
PBAL	\$0.00
SERVICE	\$3.00
BFWD	\$3.00
CLERK 1	No.000011 00001

Paying a Drive Thru Order

1. Press the **PBAL** key:



2. If necessary, add additional items, register discounts or coupons.
3. Pay the balance as you would normally tender a transaction, with **CASH**, **CHECK**, or one of the **CHARGE** functions. If the tender is greater than the balance due, change is displayed.

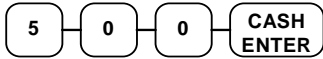

Receipt Example:

THANK-YOU CALL AGAIN	
DATE 08/15/1999 SUN	TIME 08:33
CHECK #	# 3
PBAL	\$3.00
CHECKS PAID	\$3.00
TOTAL	\$3.00
CASH	\$5.00
CHANGE	\$2.00
CLERK 1	No.000012 00001

Scale Operations

The *ER-650/650R* can be interfaced to an optional load-cell scale. The scale interface allows direct entry of an item's weight using the **SCALE** function. You can also choose "manual entry" scale operation if you are working with a standalone scale that is not interfaced to the cash register.

- PLUs must be set to "scaleable" status to allow scale multiplication. If you attempt an entry into a PLU that has been programmed "scaleable", an error tone will sound and the operator will be prompted to make a scale entry.
- PLUs can be set to "auto scale" status to speed up scale entries by automatically retrieving the weight on the scale and multiplying it times the amount entered.

A tare is the amount of weight accounted for by the container or packaging. By entering a tare weight (as required by law in some areas) the weight of the container is subtracted and only the true weight of the product is measured on the scale. By entering the tare number (1-5) the operator can automatically subtract the predetermined container weight when a product is on the scale.

- PLUs can be set to "auto tare" status to automatically subtract one of the preprogrammed tare weights when the PLU is registered.

Refer to the "Service Mode Programming" and "Program Mode Programming" chapters to set your scale options. See:

- "Function Key Assignment" to place **SCALE** and **TARE** keys on the keyboard.
- "RS232C Port 1/RS232C Port 2 Options" to attach a scale to one of the ports.
- "Function Key Programming" to set options for the **SCALE** and **TARE** keys.
- "PLU Programming" to set scaleable, auto scale, or auto tare status.

Direct Scale Entry

Place a product on the scale and access the **SCALE** function to display the weight on the cash register. Then make the appropriate entry; the PLU must have "scaleable" status.

1. Place an item on the scale.
2. Press the **SCALE** key.



3. Note that the weight is displayed on the screen. Enter the price per pound on the ten key pad. Do not use the decimal key. For example, for \$3.00, enter:

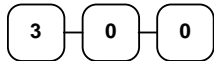

4. Press a PLU key. For example, press **PLU 1**:



THANK-YOU		
CALL AGAIN		
DATE	08/15/1999 SUN	TIME 08:33
1.50 lb	@3.00/lb	
PLU1		\$4.50
TAX1		\$0.27
TOTAL		\$4.77
CASH		\$4.77
CLERK 1	No.000011	00001

Automatic Scale Entry

Place a product on the scale and make the appropriate PLU entry. The PLU must be set with "auto scale status".

1. Place an item on the scale.
2. Press a PLU key, if the item is a preset item, or enter the price per pound on the ten key pad. Do not use the decimal key. For example, for \$3.00, enter:

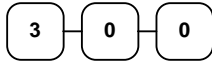

3. Press a PLU key. For example, press **PLU 1**:



THANK-YOU CALL AGAIN		
DATE	08/15/1999 SUN	TIME 08:33
1.50 lb	@3.00/lb	
PLU1		\$4.50
TAX1		\$0.27
TOTAL		\$4.77
CASH		\$4.77
CLERK 1	No.000011	00001

Tare Weight Entry

1. Place an item on the scale.
2. Enter the preprogrammed tare number. Press the **TARE** key.



3. Press the **SCALE** key.

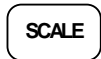

4. Note that the weight, less the tare weight, is displayed on the screen. Enter the price per pound on the ten key pad. Do not use the decimal key. For example, for \$3.00, enter:

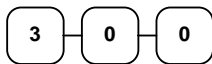

5. Press a PLU key. For example, press **PLU 1**:



THANK-YOU CALL AGAIN		
DATE	08/15/1999 SUN	TIME 08:33
1.50 lb	@3.00/lb	
PLU1		\$4.50
TAX1		\$0.27
TOTAL		\$4.77
CASH		\$4.77
CLERK 1	No.000011	00001

Manual Tare Weight Entry

1. Place an item on the scale.
2. Enter the manual tare number, **5**. Press the **TARE** key:



3. Enter the weight of the tare, for example, enter **.01**, press the tare key:



4. Press the **SCALE** key.



5. Note that the weight, less the tare weight, is displayed on the screen. Enter the price per pound on the ten key pad. Do not use the decimal key. For example, for \$3.00, enter:

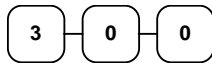

6. Press a PLU key. For example, press **PLU 1**:



THANK-YOU		
CALL AGAIN		
DATE	08/15/1999 SUN	TIME 08:33
1.50 lb	@3.00/lb	
PLU1		\$4.50
TAX1		\$0.27
TOTAL		\$4.77
CASH		\$4.77
CLERK 1	No.000011	00001

Manual Weight Entry

Operators can make manual weight entries if the item has been programmed to accept them. You must use the decimal key to enter fractional manual weights.

1. Place an item on the scale.
2. Enter the weight using the decimal key for fractional weights. Press the **SCALE** key:

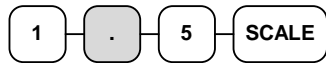

3. Enter the price per pound on the ten key pad. Do not use the decimal key. For example, for \$3.00, enter:

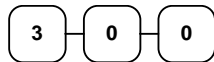

4. Press a PLU key. For example, press **PLU 1**:



THANK-YOU		
CALL AGAIN		
DATE	08/15/1999 SUN	TIME 08:33
1.50 lb	MANUAL WT. @	@3.00
PLU1		\$4.50
TAX1		\$0.27
TOTAL		\$4.77
CASH		\$4.77
CLERK 1	No.000011	00001

X Mode

Manager Mode

- ◆ Turn the control lock to the **X** position to display the **MANAGER MODE** menu:

MANAGER MODE 0.MANAGER OPERATION 1.X REPORTS 2.DECLARATION 3.REG. PRINT FORMAT 4.STOP REG PRINTING 5.TRAINING MODE 6.E.J. OPERATION
--

Manager Operation

Choose Manager Operation to access the Manager Mode screen, where operations allowed only with manager control can be performed.

1. From the **MANAGER MODE** menu press **0** to enter manager mode:

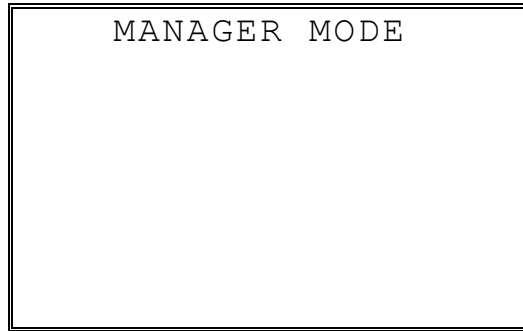

2. The **MANAGER MODE** screen displays.
3. Complete the operation requiring manager control.

X Reports

X reports read, but do not reset, totals and counters within a report.

1. From the **MANAGER MODE** menu press **1** to select X Reports:

```
MANAGER MODE
• ENTER REPORT# TO
  ISSUE X REPORT
• PRESS ENTER TO
  VIEW REPORT LIST
• PRESS ESC TO
  RETURN TO MANAGER
  MODE MENU
```

2. If you know the number of the report you wish to generate, enter the number and press **ENTER**. If you wish to look up the report number, press **ENTER** to view the X Report List, then press the number of the report you wish to generate.

```
X REPORT LIST PG 1↓
0.FINANCIAL
1.TIME
2.PLU
3.CLERK
4.GROUPS
5.DAY
6.STOCK
```

Press **PAGE DOWN** to view the second page of reports:

```
X REPORT LIST PG 2↑
7.CLERK TIME
8.OPEN CHECK
9.DRAWER TOTALS
00.PLU ZERO SALE
```

3. When a report is selected, the **X REPORT OPTIONS** screen displays:

```

X REPORT OPTIONS
RPT#: 1 FINANCIAL
1. TYPE                0 ←
   0:DAILY 1:PERIOD
2. 0:PRINT 1:DISP 0
3. IRC                 0
   0:STANDALONE
   1:ALL 2:SELECT
  
```

4. Select the **TYPE** (**DAILY** or **PERIOD**), **PRINT** or **DISPLAY**, and the **IRC** configuration. Refer to the explanations in the table below. Press **ENTER** after each selection. After the last selection, the report will start.
5. If **IRC** is **SELECT**, then the register selection displays:

```

X REPORT OPTIONS
RPT#: 1 FINANCIAL
1. TYPE                0
   0:DAILY 1:PERIOD
2. 0:PRINT 1:DISP 0
3. IRC                 2
   # 1 2 3 4 5 6 7 8
   Y←Y N N N N N N
  
```

6. Press the **YES/NO** key at each register # to select whether you wish to include each register in the consolidated report. Press **ENTER** after each selection. After the last selection, the report will start.

Field	Description
TYPE	Select X1 or X2 if available for the selected report.
IRC	Select STANDALONE , ALL , or SELECT if available for the selected report. If SELECT , the screen will prompt for selection of registers - the screen will initially show the registers available from the from/to IRC register programming, for example if the IRC range is from 1 to 3, then the selection will default to: <div style="border: 1px solid black; padding: 5px; margin: 10px auto; width: fit-content;"> <pre> 1 2 3 4 5 6 7 8 Y Y Y N N N N N </pre> </div>
OUTPUT	Select PRINT or DISPLAY output.

Declaration

Cash declaration is the process of counting and reporting media in drawer before a report is taken. "Enforce cash declaration" is an option that requires to the operator to declare amounts of media in the drawer before a financial, clerk, or cash in drawer report can be generated. The purpose of this feature is to insure accurate reporting, even in case of an overage. You can enforce declaration by setting the appropriate system option. See "System Option Programming" in the "Program Mode Programming" chapter.

1. From the **MANAGER MODE** menu press **2** to display the **DECLARATION SCREEN**:

DECLARATION SCREEN	
CASH	0.00
CHECK	0.00
F/S TEND	0.00
TOTAL	0.00

2. At the DECLARATION SCREEN, enter cash amounts, press the **CASH** key. Enter checks individually, or enter a check total, press the **CHECK** key. Enter Food Stamps, press the **F/S TEND** key. You can make as many entries as you wish, the screen will keep running totals. You may wish to use the **@/FOR** key to multiply. For example if you are declaring 37 quarters, you can enter **37**, press **@/FOR**, enter **25**, then press **CASH**. The result is added to the cash declared running total on the screen.
3. When you have completed declaration entries, press the **CASH** key again to finalize and total your declaration. The screen will display the total declared input, the drawer total and the difference (over/short).

DECLARATION SCREEN	
INPUT AMT	31.00
DRAWER TOTAL	17.00
DIFFERENCE	-14.00

Register Print Format

You can designate the *ER-650/650R* printer to print either a receipt, or a sales journal. If you select journal format, the preamble/postamble will not print. If you select receipt format, the preamble/postamble will print and the receipt will feed sufficiently for paper tear-off.

1. From the **MANAGER MODE** menu press **3** to set the receipt format:

REG. PRINTING FORMAT

REGISTER PRINTING IS
CURRENTLY RECEIPT

TO SET TO JOURNAL
PRESS YES AND ENTER

2. The **REG. PRINTING FORMAT** screen displays. Press the **YES/NO** key to toggle from receipt to journal format. The screen will display the current status. Press **ENTER** to set the new format.

Stop Register Printing

You can turn the register printer to an *on* or *off* condition. In the *off* condition transactions will not be printed, but reports will continue to print, if requested.

1. From the **MANAGER MODE** menu press **4** to set printing on or off:

REG. PRINTING ON/OFF

REGISTER PRINTING
IS CURRENTLY ON

TO TURN OFF
PRESS YES AND ENTER

2. The **REG. PRINTING ON/OFF** screen displays. Press the **YES/NO** key to toggle from receipt on to receipt off. The screen will display the current status. Press **ENTER** to set the new format.

Note: When the receipt is off, a receipt may be printed after the sale by pressing **ENTER** after the transaction is complete.

Training Mode

A training mode is available so that the register can be operated, to practice registrations, without updating totals and counters. If you choose to use training mode, you must set a training mode password (see "Training Mode Password" in the "Program Mode Programming" chapter.)

Note: If you make registrations to check tracking numbers in training mode, remember that the check tracking total **will** be updated. Remember to pay, or clear any check tracking registrations before resuming normal operations. You must close all open checks prior to entering training mode.

1. From the **MANAGER MODE** menu press **5** to enter or exit training mode:

ENTER/EXIT TRAINING

REGIST. IS CURRENTLY
NOT IN TRAINING
TO ENTER TRAINING
ENTER 4 DIGIT PASSWD
AND PRESS ENTER

2. The **ENTER/EXIT TRAINING** screen displays. The screen will display the current status. To enter training mode, type your four digit password (you must enter preceding zeros) and press **ENTER**. To exit training mode, type **0000** and press **ENTER**.

E.J. Operation

An electronic journal feature is available on the *ER-650/650R*. The electronic journal captures the sales journal in the register memory. If you intend to use the electronic journal, you must allocate sufficient memory (see "Memory Allocation" in the "Service Mode Programming" chapter) and activate the journal and set related journal capture options (see "System Option Programming" in the "Program Mode Programming" chapter.)

Use this program to print all or selected parts of the journal memory. Note, this program will not clear the electronic journal. See "Reset Electronic Journal" in the "Z-Mode" chapter to clear the E.J.

1. From the **MANAGER MODE** menu press **6** to display the electronic journal menu:

```
ELECTRONIC JOURNAL↓
0.PRT ALL EJ
1.PRT ONLY CASH
2.PRT ONLY CHECK
3.PRT ONLY MISC/T
4.PRT ONLY %
5.PRT ONLY RA/PO
6.PRT ONLY RETURN
```

2. Press **PAGE DOWN** to view the remaining electronic journal options:

```
ELECTRONIC JOURNAL↑
7.PRT ONLY EC/VOID
8.PRT ONLY NOSALE
9.PRT ONLY CANCEL
00.PRT BY CLERK
```

3. Type the digit that represents the portion of the electronic journal you wish to print. If you select **00** for print by clerk, you will be prompted to enter the appropriate clerk number.

Z Mode

Reset Report Mode

- ◆ Turn the control lock to the Clear Totals position to display the **RESET REPORT MODE** menu:

```
RESET REPORT MODE
0.Z REPORTS
1.RESET E.J.
2.PC COMMUNICATION
3.PLU LOOKUP PGM
4.AGE VERIFICATION
5.KP STARTING NO.
```

Z Reports

1. From the **RESET REPORT MODE** menu press **1** to select Z Reports:

```
RESET REPORT MODE
● ENTER REPORT# TO
  ISSUE Z REPORT
● PRESS ENTER TO
  VIEW REPORT LIST
● PRESS ESC TO
  RETURN TO RESET
  REPORT MODE MENU
```

2. If you know the number of the report you wish to generate, enter the number and press **ENTER**. If you wish to look up the number, press **ENTER** to view the Z Report List, then press the number of the report you wish to generate.

```
Z REPORT LIST PG 1↓
0.FINANCIAL
1.TIME
2.PLU
3.CLERK
4.GROUPS
5.DAY
6.STOCK
```

Press **PAGE DOWN** to view the second page of reports:

```
Z REPORT LIST PG 2↑
7.CLERK TIME
8.OPEN CHECK
```

3. When a report is selected, the **Z REPORT OPTIONS** screen displays:

```

Z REPORT OPTIONS
RPT#: 1 FINANCIAL
1. TYPE                0 ←
   0:DAILY 1:PERIOD
2. 0:PRINT             0
3. IRC                 0
   0:STANDALONE
   1:ALL 2:SELECT

```

4. Select the TYPE (DAILY or PERIOD and the IRC configuration. Refer to the explanations in the table below. Press **ENTER** after each selection. After the last selection, the report will start.
5. If IRC is SELECT, then the register selection displays:

```

Z REPORT OPTIONS
RPT#: 1 FINANCIAL
1. TYPE :              0
   0:DAILY 1:PERIOD
2. 0:PRINT             0
3. IRC                 2
   # 1 2 3 4 5 6 7 8
     Y←Y N N N N N N

```

6. Press the **YES/NO** key at each register # to select whether you wish to include each register in the consolidated report. Press **ENTER** after each selection. After the last selection, the report will start.

Field	Description
TYPE	Select Z1 or Z2 if available for the selected report.
IRC	Select STANDALONE, ALL, or SELECT if available for the selected report. If SELECT, the screen prompts for selection of registers - the screen will initially show the registers available from the from/to IRC register programming, for example if the IRC range is from 1 to 3, then the selection will default to: <div style="border: 1px solid black; padding: 5px; margin: 5px 0;"> <pre> 1 2 3 4 5 6 7 8 Y Y Y N N N N N </pre> </div>

Reset Electronic Journal

An electronic journal feature is available on the *ER-650/650R*. The electronic journal captures the sales journal in the register memory. If you intend to use the electronic journal, you must allocate sufficient memory (see "Memory Allocation" in the "Service Mode Programming" chapter) and activate the journal and set related journal capture options (see "System Option Programming" in the "Program Mode Programming" chapter.)

Use this to clear the journal memory. The journal will not be printed. To read all or selected parts of the E.J., see "E.J. Operation" in the "X-Mode" chapter.

1. From the **RESET REPORT MODE** menu press **2** to clear the electronic journal:

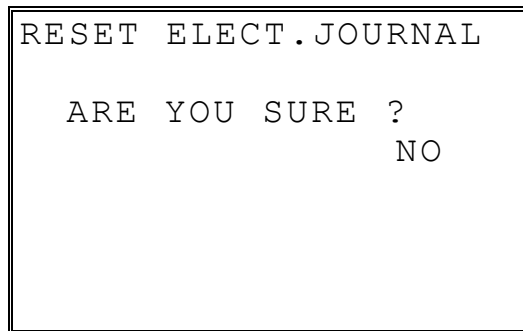

```
RESET ELECT. JOURNAL

ARE YOU SURE ?
                NO
```

2. The screen asks: **ARE YOU SURE ?** Press the **YES/NO** key to toggle to yes, then press **ENTER** to clear the report.

PC Communication

To be polled by a PC, the register must be placed in the PC ONLINE MODE.

You can place the register in ONLINE MODE manually by selecting the PC COMMUNICATION function from the RESET REPORT MODE menu. If you wish to complete unattended polling, you can program the *ER-650/650R* to automatically enter the PC ONLINE MODE at a scheduled time. See "PC Schedule Time" in the "Program Mode Programming" chapter to set a polling time.

You must also configure one of the RS232C ports for PC communications. See the "Service Mode Programming" chapter.

Note: PC polling requires optional polling software. Contact your authorized dealer for information.

PLU Lookup Program

You can assign up to five **PLU LOOK UP** keys on the keyboard. (See “Function Key Assignment” in the “Service Mode Programming” chapter.) Each of the **PLU LOOK UP** keys can be programmed here to list specific PLUs.

1. From the **RESET REPORT MODE** menu press **3** to select **PLU LOOKUP PGM**. The **PLU LOOKUP PGM** screen displays:

PLU LOOKUP PGM
PUSH LOOKUP NUMBER TO BE PROGRAMMED AND PRESS ENTER (1-8) 0 ←

2. Enter the number of the **PLU LOOKUP** key you wish to program, press **ENTER**.

1 .	0 ←
2 .	0
3 .	0
4 .	0
6 .	0
6 .	0
7 .	0
8 .	0

3. With the cursor pointed at the first position of the **PLU LOOKUP** screen, select a PLU by typing the PLU number and pressing **ENTER**. The descriptor for the PLU will display, and the cursor will advance to the next position.

1 .	PLU123
2 .	0 ←
3 .	0
4 .	0
5 .	0
6 .	0
7 .	0
8 .	0

4. Continue to select PLUs for the **PLU LOOKUP** key as necessary. If you are editing an existing **PLU LOOK UP** key, press **ENTER** to advance the cursor without changing the current line.
5. If you wish to remove an item from the **PLU LOOKUP** key, place the cursor on the line to be removed, press the **VOID** key.
6. Press **ESC** to return to the **RESET REPORT MODE** menu and save changes.

Age Verification

In most areas, the sale of tobacco and/or alcoholic beverages to minors is prohibited. The *ER-650/650R* offers an age verification feature that helps control the sale of restricted items by forcing the operator to enter a birth date before a controlled item can be registered. If the date entered shows that the customer has not yet reached the appropriate age, the item cannot be registered. This feature serves as a reminder to check the customer's identification.

Because different categories of items might require different ages (for example, alcohol might require age 21, while tobacco might require age 18) up to five different age categories can be defined.

This program allows you to set the required age for each of the five available age categories. See "Group Programming" in the "Program Mode Programming" chapter to link an age category to groups of PLU items.

Note: When age verification is implemented, an age entry is required only for the first controlled item from each age category.

1. From the **RESET REPORT MODE** menu press **4** to select **AGE VERIFICATION**. The **AGE VERIFICATION** screen displays:

AGE VERIFICATION		
1 .		0 ←
2 .		0
3 .		0
4 .		0
5 .		0

2. Enter the age required for the first group of age-restricted items, press **ENTER**. (For example, enter 21 if the sale of liquor requires an age of 21. You must also program the age verification category of "1" for all groups of liquor items.)
3. If other items are to be restricted by a different age, program additional age verification groups as necessary.
4. Press **ESC** to return to the **RESET REPORT MODE** menu and save changes

KP Starting No.

In many fast service installations multiple registers may print to the kitchen. This feature allows the user to assign the KP starting order, allowing the staff to track the register that each order originates from.

1. From the **RESET REPORT MODE** menu press **5** to select **KP STARTING ORDER No.** The **KP STARTING ORDER No.** screen displays:

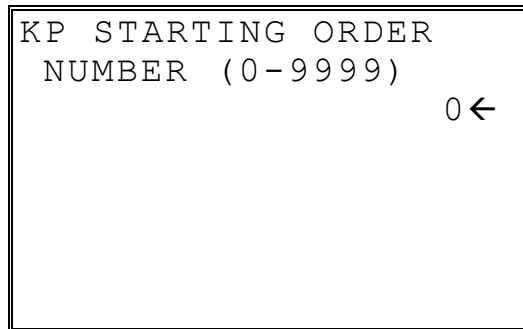

KP STARTING ORDER
NUMBER (0-9999) 0 ←

2. Enter the order number that KP orders will start with and press **ENTER**.
3. Set this number at each register.

Service Mode Programming

Overview

The following procedures are done from the Service Mode menu:

- Hardware Tests
- Clear all totals
- Clear grand total
- Clear PLU file
- EPROM Information
- Memory Allocation
- Assignment of functions to keyboard locations
- IRC Options
- RS232C Port 1 & 2 Options

- ◆ Turn the key to the **SM** position (one position clockwise from the **PGM** position) to display the **SERVICE MODE** menu:

```
SERVICE MODE    ↓
0. HW TEST
1. CLEAR ALL TOTALS
2. CLEAR GRAND TOTAL
3. CLEAR PLU FILE
4. EPROM INFO.
5. MEMORY ALLOCATION
6. KEY ASSIGNMENT
```

- ◆ Press **PAGE DOWN** to view the remainder of the SERVICE MODE menu:

```
SERVICE MODE    ↑
7. IRC OPTIONS
8. RS232C PORT 1
9. RS232C PORT 2
```

Clearing Memory

Before you use your *ER-650/650R* for the first time, you must perform a memory clear to insure that all totals and counters are cleared and that the default program is installed.

CAUTION: The procedures described in this area are security sensitive. Clearing the *ER-650/650R* memory after the register is put into service will erase all programming as well as totals and counters. Do not share this information with unauthorized users and distribute the special SERVICE-Mode key only to those you may want to perform these functions.

Memory All Clear

ER-650

1. Turn the power switch located on the right side of the register to the **OFF** position.
2. Turn the control lock to the **SM** position.
3. Press and hold the key position where the **CHECK** key is located on the default keyboard layout.
4. Continue to hold the **CHECK** key while turning the power switch to the **ON** position. The message: "RAM ALL CLEAR SERV." displays on the screen.
5. Press the upper left key of the keyboard, then the lower left key, then the upper right key, and finally press the lower right key.

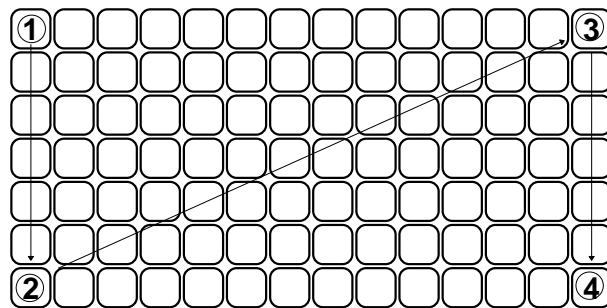

6. The display will monitor the memory clear process, which takes about 1 minute. When complete, the printer will print the message: "RAM ALL CLEAR OK !" The SERVICE MODE menu will display.

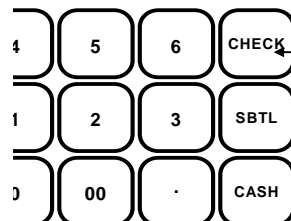

TO MEMORY ALL CLEAR:

Press and hold the **CHECK** key position during power-up in SERVICE mode.

ER-650R

1. Turn the power switch located on the right side of the register to the **OFF** position.
2. Turn the control lock to the **SM** position.
3. Press and hold the key position where the **CHECK** key is located on the default keyboard layout.
4. Continue to hold the **CHECK** key while turning the power switch to the **ON** position. The message: "RAM ALL CLEAR SERV." displays on the screen.
5. Press the upper left key of the keyboard, then the lower left key, then the upper right key, and finally press the lower right key.

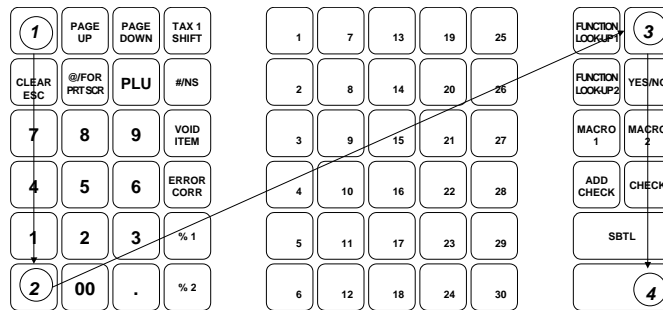

6. The display will monitor the memory clear process, which takes about 1 minute. When complete, the printer will print the message: "RAM ALL CLEAR OK !" The **SERVICE MODE** menu will display.

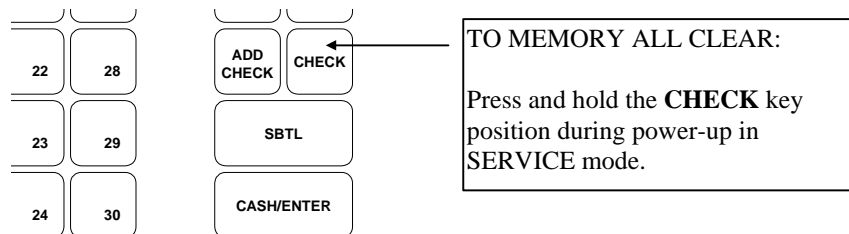

Hardware Test

Various components of the *ER-650/650R* are tested by using this program.

1. From SERVICE MODE menu press **0** to display the H/W TEST menu:

H/W TEST 0 . TEST PRINTER 1 . TEST DISPLAY 2 . TEST KEYBOARD 3 . TEST MODE & CLERK 4 . TEST RS-232 5 . PRINTING PATTERN 6 . IRC RANGE TEST

2. Press the digit representing the test you wish to perform. See the table that follows for notes about each test.

Hardware Test Table

TEST	NOTES
PRINTER	A printer test pattern is printed. The H/W TEST menu automatically returns when the test is complete.
DISPLAY	A display test is initiated. The H/W TEST menu automatically returns when the test is complete.
KEYBOARD	The display indicates: "KEYBOARD TEST". Press any key location to display its' position. Turn the key lock to end the test.
MODE	Check the mode lock and/or the optional "real" clerk key lock with this test. As you turn the key lock, the display will show the current position. The display will also indicate the "real" key that is inserted. Return the key to the SERVICE position to end the test.
RS-232	Select LOOP TEST PORT 1, LOOP TEST PORT 2, or LOOP TEST IRC. (to loop test port 1 or 2 , a loop back connector must be in place.) Then after a moment, the display indicates NG (not good) or OK.
PRINTING PATTERN	ENDLESS PRINTING and LIFE TEST PRINT are factory tests. Toggle the power switch on and off to end the test.
IRC RANGE	This test checks communication with each register programmed in IRC options. Reports pass or fail.

Clear All Totals

This selection clears all totals and counters, including the grand total.

1. From **SERVICE MODE** menu press **1** to display the **CLEAR ALL TOTALS** screen:

```
CLEAR ALL TOTALS
ARE YOU SURE ?      N
```

2. Press the **YES/NO** key to display **Y** at the "ARE YOU SURE ?" question. Press **ENTER**.
3. The display reads: "PLEASE WAIT". The message "ALL TOTAL CLEAR" is printed and the screen returns to the **SERVICE MODE** menu.

Clear Grand Total

This selection clears only the grand total.

1. From **SERVICE MODE** menu press **2** to display **CLEAR GRAND TOTALS** screen:

```
CLEAR GRAND TOTALS
ARE YOU SURE ?      N
```

2. Press the **YES/NO** key to display **Y** at the "ARE YOU SURE ?" question. Press **ENTER**.
3. The message "GRAND TOTAL CLEAR" is printed and the screen returns to the **SERVICE MODE** menu.

Clear PLU File

This selection clears the entire PLU file, including totals, counters and programming.

1. From **SERVICE MODE** menu press **3** to display the **CLEAR PLU FILE** screen:

```
CLEAR PLU FILE
ARE YOU SURE ?      N
```

2. Press the **YES/NO** key to display **Y** at the "ARE YOU SURE ?" question. Press **ENTER**.
3. The message "PLU FILE CLEAR" is printed and the screen returns to the **SERVICE MODE** menu.

EPROM Information

This selection displays the version, check sum and date of the EPROM. You may be asked to check you EPROM version if you contact your dealer for assistance. You should also verify that all registers in an IRC configuration have the same version EPROM.

1. From **SERVICE MODE** menu press **4**. The "PLEASE WAIT" message displays momentarily until the *ER-650/650R* EPROM INFO screen displays:

```
ER-650/650R EPROM
INFO.

VERSION   :   1.0 USA
CHECKSUM  :           C5FC
JUNE 24 2002

PRESS CLEAR KEY
```

2. Press **CLEAR** to return to the **SERVICE MODE** menu.

Memory Allocation

Note: You must step through every memory allocation field to implement new memory allocation. If you press **CLEAR**, at any field you will abort memory allocation processes without making changes. Changes to Memory Allocation will clear all program data.

1. At the **SM** control lock position menu, press **5** for Memory Allocation programming. The **MEMORY ALLOCATION** screen displays:

```
MEMORY ALLOCATION ↓
TTL AVAIL:      187136
TTL USED:       186980
# PLUS          1000←
# PRICE LVLS (1-5) 1
# CLERKS        10
# GROUP TOTALS  20
```

2. The total available memory is displayed on the first line of the screen (TTL AVAIL). The total memory currently allocated is displayed on the second line of the screen (TTL USED). The TTL USED field is updated when you complete a change and press **ENTER**.

Starting at the PLUs field, enter the quantity of each memory field. Press **ENTER** after each entry, and the cursor will move to the next field. Page 2 of Memory Allocation will display after the # OF GROUP TOTALS field is set:

```
MEMORY ALLOCATION ↑
TTL AVAIL:      187136
TTL USED:       186980
# EJ LINES      1500←
# CHECKS        20
Y=HARD/N=SOFT  CHK N
# LINES/SFT CH  50
```

3. Continue filling each field until complete. Press **ENTER** after setting the last field, "# LINES/SOFT CH". The screen will display "ARE YOU SURE?". N (No) will display as the default answer to the question. If you wish to implement the new allocation you have entered, press the **YES/NO** key, then press **ENTER**.
4. The message "PLEASE WAIT . . ." displays until the printer prints either: "MEMORY ALLOCATION OK !" or "MEMORY ALLOCATION SIZE OVER" if you attempt to allocate features requiring more memory than is available.
5. The **SERVICE MODE** menu screen displays when memory allocation programming is completed.

Function Key Assignment

Any key location may be reprogrammed with a function from the list of available functions on page 111 of this manual. The default program installs the functions as they are shown with the standard key legends.

To change the function on a specific key:

1. At the **SM** control lock position menu, press **6** for Key Assignment programming. The **KEY ASSIGNMENT** screen displays:

```
KEY ASSIGNMENT

PUSH KEY TO BE
PROGRAMMED

                                0 ←
```

2. Press any key location. The current key assignment is displayed:

```
KEY ASSIGNMENT

KEY NUMBER: 102
CURRENT ASSIGNMENT:
    CASH
ENTER NEW CODE,
PRESS ENTER

                                0 ←
```

3. Enter a new key code from the list of "Function Key Codes" on page 111 and press **ENTER**, or press **PAGE DOWN** to display a list of key codes on the screen.

```
FUNCTION      KEYCODE
-----
NLU#1 - NLU#80 (1-80)
ONE           81
TWO          82
THREE        83
FOUR         84
FIVE         85
```

4. With the key code list displayed, you can press **PAGE DOWN** repeatedly, or **PAGE UP** until you find the key code you wish to use. Type the key code number you wish to place and press **ENTER**. The **KEY ASSIGNMENT** screen displays again:

```
KEY ASSIGNMENT

PUSH KEY TO BE
PROGRAMMED

PRESS ENTER TO EXIT
0 ←
```

5. Continue to program function key locations as necessary. When you have completed function key programming, press the **ENTER** key to finalize. The screen displays:

```
KEY ASSIGNMENT

PRESS ENTER TO
SAVE CHANGES
OR
PRESS ESCAPE TO EXIT
WITHOUT SAVING
```

6. Press **ENTER** to save the changes you have made, or press **ESC** to exit without saving changes.
7. The printer will print out a receipt showing all the changes made to the keyboard.

Notes:

1. Numeric keys (0-9), **CLEAR/ESC**, and **CASH/ENTER** cannot be removed from the keyboard unless they have been assigned to a new keyboard location. This protects the programmer from accidentally removing keys that are required for register programming and operations.
 2. If you wish to program the **CASH/ENTER** key, select it immediately after selecting **KEY ASSIGNMENT** from the **SERVICE MODE** menu. After the initial key is programmed, the **CASH/ENTER** key is used to finalize the program.
-

Function Key Codes

Code	Function	Code	Function	Code	Function
1	NLU 1	117	CURRENCY CONV.1	156	PAID OUT 2
	<i>through</i>	118	CURRENCY CONV.2	157	PAID OUT 3
80	NLU 80	119	CURRENCY CONV.3	158	PAPER FEED
81	Numeric 1	120	CURRENCY CONV.4	159	PLU PRICE INQ
82	Numeric 2	121	DRIVE THRU	160	PRINT CHECK
83	Numeric 3	122	EAT-IN	161	PROMO
84	Numeric 4	123	ERROR CORRECT	162	RECD ON ACCT 1
85	Numeric 5	124	F/S SHIFT	163	RECD ON ACCT 2
86	Numeric 6	125	F/S SUB	164	RECD ON ACCT 3
87	Numeric 7	126	F/S TEND	165	SBTL
88	Numeric 8	127	FUNCTION LOOK UP 1	166	SCALE
89	Numeric 9	128	FUNCTION LOOK UP 2	167	SERVICE
90	Numeric 0	129	GUEST #	168	TABLE #
91	Numeric 00	130	PLU(CODEENTRY)	169	TARE
92	Decimal	131	PRICE LEVEL 1	170	TAKE OUT
93	#/NS	132	PRICE LEVEL 2	171	TAX EXEMPT
94	%1	133	PRICE LEVEL 3	172	TAX SHIFT 1
95	%2	134	PRICE LEVEL 4	173	TAX SHIFT 2
96	%3	135	PRICE LEVEL 5	174	TAX SHIFT 3
97	%4	136	MACRO 1	175	TAX SHIFT 4
98	%5	137	MACRO 2	176	TIME IN/OUT
99	@/FOR (PRT SCREEN)	138	MACRO 3	177	TIP
100	ADD CHECK	139	MACRO 4	178	VOID ITEM
101	CANCEL	140	MACRO 5	179	WASTE
102	CASH(ENTER)	141	MACRO 6	180	YES/NO
103	CHARGE 1	142	MACRO 7	181	VALIDATION
104	CHARGE 2	143	MACRO 8	182	PLU LOOKUP1
105	CHARGE 3	144	MACRO 9	183	PLU LOOKUP2
106	CHARGE 4	145	MACRO 10	184	PLU LOOKUP3
107	CHARGE 5	146	MDSE RETURN	185	PLU LOOKUP4
108	CHARGE 6	147	MODIFIER 1	186	PLU LOOKUP5
109	CHARGE 7	148	MODIFIER 2	187	PLU LOOKUP6
110	CHARGE 8	149	MODIFIER 3	188	PLU LOOKUP7
111	CHECKCASHING	150	MODIFIER 4	189	PLU LOOKUP8
112	ENDORSE	151	MODIFIER 5	190	FINALIZE
113	CHECK TEND	152	P/BAL	191	INACTIVE
114	CHECK TRACK #	153	PAGE DOWN		
115	CLEAR (ESC)	154	PAGE UP		
116	CLERK #	155	PAID OUT 1		

IRC Options

1. At the **SM** control lock position menu, press **7** for IRC Option programming. The **IRC OPTIONS** screen displays:

IRC OPTIONS		
REG# (1-8)		1 ←
STORE#	000000	
FROM REG#		1
TO REG#		1
IRC RETRIES (0-99)		3

2. Refer to the table below to fill the fields on the **IRC OPTIONS** screen.
3. Press the **CLEAR** key to finalize and return to the **SERVICE MODE** screen.

Option	Entry	Description
REG#	Numeric 1 digit	Enter the IRC number of this register (1-8).
STORE#	Numeric 6 digits	Enter the store number.
FROM REG#	Numeric 1 digit	Enter the first register number in the IRC system.
TO REG#	Numeric 1 digit	Enter the last register number in the IRC system.
IRC RETRIES	Numeric 2 digits	Each retry equals approximately 0.5 seconds.

RS232C Port 1/RS232C Port 2 Options

1. At the **SM** control lock position menu, press **8** for RS232C Port 1 programming or **9** for RS232C Port 2 programming. The appropriate **PORT PROGRAM** screen displays:

```
PORT 1 PROGRAM pg1
BAUD RATE          0←
 0: 9,600   1:1,200
 2: 2,400   3:4,800
 4:19,000
PARITY CHECK       0
0:NONE 1:ODD 2:EVEN
DATA BITS (0:8 1:7) 0
```

2. At each field, press **ENTER** to view the selections. Enter the digit representing your selection.
3. Press **PAGE DOWN** to view page 2 of the RS232C port program:

```
PORT 1 PROGRAM pg2
STOP BITS (0:1 1:2) 0←
DEVICE FUNCTION    0
-----
0:NONE 1:PC   2:SCL
3:RJ   4:RP   5:LT
6:SCAN 7:COIN 8:LIQ
9:POLE
```

4. Press **PAGE DOWN** to view page 3 of the RS232C port program:

```
PORT 1 PROGRAM pg3
INITIAL FEEDING LINE
ON KP (0-20)        0←
ENDING FEEDING LINE
ON KP (0-20)        0
INITIAL FEEDING LINE
ON SLIP (0-20)      7
```

5. Press **PAGE DOWN** to view page 4 of the RS232C port program:

```
PORT 1 PROGRAM pg4
PRINT LINE ON GUEST
CHECK(0-50)      0←
SCALE TYPE
0:NCI    1:CAS    0
PRINTER TYPE      0
0:NONE
1:SAM SRP-100
```

6. Press **PAGE DOWN** to view page 5 of the RS232C port program:

```
PORT 1 PROGRAM pg5
PRINTER TYPE      0←
2:SAM SRP-270
3:SAM SRP-300
4:SAM SRP-350
5:CITIZEN 3550/3551
6:CITIZEN 810
7:CITIZEN 230
```

7. Press **PAGE DOWN** to view page 6 of the RS232C port program:

```
PORT 1 PROGRAM pg6
PRINTER TYPE      0←
8:EPSON TM-T88-2
9:EPSON U200
10:EPSON U295
11:EPSON U300
12:EPSON U325
13:EPSON U375
```

8. Press **PAGE DOWN** to view page 7 of the RS232C port program:

```
PORT 1 PROGRAM pg7
PRINTER TYPE      0←
14:STAR SP-200
15:STAR SP-298
16:STAR SP-300
17:STAR TSP-200
```

9. Press **PAGE DOWN** to view page 8 of the RS232C port program:

```
PORT 1 PROGRAM pg8
POLE DISLAY TYPE  0←
0:EPSON      1:ICD
RS232C RETRY
TIMES (0-99)    1
```

10. Refer to "RS232C Settings Screen Program Notes" on the next page to fill the fields for each port.
11. Press the **CLEAR** key to finalize and return to the **SERVICE MODE** screen.

RS232C Settings Screen Program Notes

Option	Description
BAUD RATE	Select 1200, 2400, 4800, 9600, or 19200 from the pop-up window; 9600 is default.
PARITY	Select NONE, EVEN, or ODD from the pop-up window; NONE is default.
DATA BITS	Select 8 or 7 from the pop-up window; 8 is default.
STOP BITS	Select 1 or 2 from the pop-up window; 1 is default.
DEVICE FUNCTION	<p>Enter the code number for the device you wish to attach to this port from the code numbers displayed. The device function codes are:</p> <ul style="list-style-type: none"> 1: PC Communications 2: Scale 3: Remote Journal Printer 4: Remote Printer 5: Kitchen Video 6: Scanner 7: Coin Dispenser 8: Liquor System 9: Remote Pole Display
PRINT LINE ON GUEST CHECK (0-50)	Enter the number of lines that represent the maximum that can be printed on a single guest check.
SCALE TYPE	Select the digit that represents the scale type connected to this port.
PRINTER TYPE	Select the digit that represents the printer type connected to this port.
POLE DISPLAY TYPE	Select the digit that represents the pole display type connected to this port.
RS232C RETRY TIMES	Set the number of retries for RS232C communication (about 0.5 seconds each.)

Program Mode Programming

Descriptor Programming Methods

Descriptors are programmable for PLUs, function keys, groups, clerks and the logo/messages. There are two methods available to program descriptors, the *Program Overlay Method* and the *Descriptor Code Method*.

This chapter describes both methods. Refer to each program area for specific steps for programming PLUs, groups, function keys, etc.

Program Overlay Method

When the descriptor field is selected on the program screen, you can simply type the descriptor using the overlay below. Press enter to finalize your descriptor.

!	PAGE UP	PAGE DOWN	BACK SPACE	A	G	M	S	Y	()-
CLEAR ESC			DOUBLE	B	H	N	T	Z	+/=	YES/NO
7	8	9	SPACE	C	I	O	U	!/@	</,	>/.
4	5	6	SPACE	D	J	P	V	#\$	"/	?//
1	2	3	SPACE	E	K	Q	W	%/^	:/;	
0	00	.	CAPS	F	L	R	X	&/*	ENTER	

The program overlay method is the default method for programming descriptors.

Descriptor Code Method

If you customize your keyboard by covering key locations, or by installing double or quad size keys, you will need to program descriptors using the descriptor code method.

See “System Option Programming” on page 142. You must set the option “PGM DESC BY CODE” found on page 143 to **Y** to use the descriptor code method.

Program Sequence

1. With the cursor pointed at a descriptor field, refer to the Descriptor Code Chart below and type the code for the first character. Press the decimal [.] key.
2. For each additional character, type the code and press the decimal key. Each character will be displayed as it is entered.
3. Press **ENTER** when the descriptor is complete.

Program Example

To program the descriptor "APPLE", type:

[65] [.] [80] [.] [80] [.] [76] [.] [69] [.] [ENTER]

A P P L E

Note:

For lower case enter **98** after the descriptor code. For example:

a = [6598] [.] [ENTER]

For DOUBLE (wide) characters enter **99** after the descriptor code. For example:

▲ = [6599] [.] [ENTER]

Descriptor Code Table

Char.	Space	!	"	#	\$	%	&	'	()
Code	32	33	34	35	36	37	38	39	40	41
Char.	*	+	,	-	.	/	0	1	2	3
Code	42	43	44	45	46	47	48	49	50	51
Char.	4	5	6	7	8	9	:	;	<	=
Code	52	53	54	55	56	57	58	59	60	61
Char.	>	?	@	A	B	C	D	E	F	G
Code	62	63	64	65	66	67	68	69	70	71
Char.	H	I	J	K	L	M	N	O	P	Q
Code	72	73	74	75	76	77	78	79	80	81
Char.	R	S	T	U	V	W	X	Y	Z	[
Code	82	83	84	85	86	87	88	89	90	91
Char.]	^	_		Back-space	CAPS	Double	1line Delete	
Code	92	93	94	95	96	97	98	99	0	

Program Mode Menu

- ◆ Turn the control lock to the **PGM** position. The first page of the **PROGRAM MODE** menu displays:

```
PROGRAM MODE  ↓
0 . PLU
1 . GROUP
2 . SALES TAX
3 . SYSTEM OPTION
4 . PRINT OPTION
5 . FUNCTION KEYS
6 . CLERK
```

- ◆ Press **PAGE DOWN** to view the remainder of the PROGRAM MODE menu:

```
PROGRAM MODE  ↑
7 . LOGO DESC .
8 . NLU CODE# PGM .
9 . DOWNLOAD PROGRAMS
00 . MORE
```

- ◆ Press **00** to view the MORE PROGRAMS menu:

```
PROGRAM MODE page2↓  
0.CLERK I/O  
1.PLU STOCK  
2.DRAWER LIMIT  
3.CHECK CHANGE LIMIT  
4.TIME & DATE  
5.TARE WEIGHT  
6.MACRO
```

- ◆ Press **PAGE DOWN** to view the remainder of the PROGRAM MODE page 2 menu:

```
PROGRAM MODE page2↑  
7.MACHINE NO.  
8.PC SCHEDULE TIME  
9.TRAINING MODE P/W  
00.SCAN
```

PLU Programming

To accommodate UPC scanning, each PLU can be given an identifying number up to 14 digits in length.

1. At the **PGM** control lock position menu, press **0** for PLU Programming. The **PLU PROGRAMMING** screen displays:

```
PLU PROGRAMMING
0.ADD/MODIFY PLU
1.DELETE PLU
```

Add/Modify PLU

1. Press **0** to add or modify a PLU. The **PLU NUMBER** screen displays:

```
PLU NUMBER
* ENTER PLU NUMBER
AND PUSH PLU, OR
* PRESS A PLU KEY ON
THE KEYBOARD
0 ←
```

2. To view the **PLU # PROGRAMMING** screen, enter the number of the PLU you wish to program, or press a PLU key on the keyboard, or press a modifier key followed by a the PLU key on the keyboard, or scan the barcode on an item.
3. Refer to "PLU Options - Reference Information" on page 126 to make program entries or changes, press the **CLEAR** key to finalize and return to the **PROGRAM MODE** screen.

Descriptor

Type the descriptor using the Program Overlay, or by using the descriptor code method (see page 117.) The overlay is automatically activated when the cursor is pointing at the DESC field.

of PRICE/HALO fields displayed is determined by memory allocation.

```
PLU#                1 P1
DESC: PLU1          ←
PRESET              Y ←
PRICE/HALO1         0
PRICE/HALO2         0
PRICE/HALO3         0
PRICE/HALO4         0
PRICE/HALO5         0
```

Press **ENTER** to advance the arrow to the next option.

Press **YES/NO** to toggle from "Y" to "N" for yes or no decisions.

```
PLU#                1 P2
PRESET OVERRIDE     Y ←
TAXable BY: 1 2 3 4
                  N N N N
FOOD STMP ELIGIBLE N
GROUP #1 (1-20)    1
GROUP #2 (1-20)    0
GROUP #3 (1-20)    0
```

Press **PAGE DOWN** to view the second PLU Programming screen. Press **PAGE UP** once to return to the first option on a screen. Press **PAGE UP** again to return to the previous screen.

```
PLU#                1 P3
NEGATIVE ITEM       N ←
HASH                N
SINGLE ITEM          N
NON-ADD # COMP.    N
GALLONAGE ITEM      N
INVENTORY ITEM      N
DISABLE             N
```

Press **PAGE DOWN** to view the third PLU Programming screen.

```
PLU#                1 P4
SCALABLE            N ←
AUTO SCALE          N
AUTO TARE (1-5)    0
CONDIMENT           N
COMP. CONDIMENT     N
PRINT ON RECEIPT    Y
PRINT ON DISPLAY    Y
```

Press **PAGE DOWN** to view the fourth PLU Programming screen.

```

PLU#                1 P5
PRINT ON CHECK      Y←
PRT PRICE ON RCPT  Y
PRT PRICE ON CHK    Y
DISABLE PROMO       N
COUNTER NOT RESET  N
PRESET OVERRIDE
IN MGR CONTROL      N

```

← Press
PAGE DOWN
to view the 5th
PLU
Programming
screen.

If you wish the registration of this PLU to automatically cause the registration of another PLU, Enter the PLU # you wish to link with the 10-key pad. Enter '0' for no link.

→

```

PLU#                1 P6
LINK PLU:
                                0

```

← Press
PAGE DOWN
to view the 6th
and last PLU
Programming
screen.

PLU Options - Reference Information

Option	Entry	Description
DESC	Alpha numeric 12 character	You can program a descriptor for each PLU. Type the descriptor using the Program Overlay, or by using the descriptor code method (see page 117.) The overlay is automatically activated when the cursor is pointing at the DESC field. The default descriptors are PLU #1, PLU #2, etc.
PRESET	Y or N	Choose Y for a preset PLU. Choose N for an open PLU. Open PLUs accept amount entries. Use open PLUs to enter different priced items into the same PLU. Preset PLUs automatically register a preprogrammed price when the PLU is entered. Use preset PLUs to register an individual item quickly and accurately. For example, cigarette packs or food items can be assigned to PLUs.
PRICE/HALO1 PRICE/HALO2 PRICE/HALO3 PRICE/HALO4 PRICE/HALO5	7 digit amount	Up to five price levels are available. (Note that price level fields 2-5 will display only if you allocate memory for additional price levels.) If the PLU is open, the amount entered here is the high amount lock out (HALO). You can limit errors by setting the maximum amount that can be entered into a PLU. If the PLU is preset, the amount entered here is the amount that is registered automatically when the PLU is entered.
PRESET OVERRIDE	Y or N	If Y , you can enter a price to override the preset price.
TAXable BY TAX1 TAXable BY TAX2 TAXable BY TAX3 TAXable BY TAX4	Y or N	Select N for non taxable items. Select Y to apply the appropriate tax automatically for this PLU.
FOOD STMP ELIGIBLE	Y or N	Select Y to accumulate a total of food stamp eligible items in the current sale. The total can be viewed by pressing the F/S SUB key and food stamps can be tendered with the F/S TEND key.
GROUP #1 GROUP #2 GROUP #3	0-99	For each of three group assignments, enter a group where this PLU's sales will accumulate. The number of groups available is determined by memory allocation.
NEGATIVE ITEM	Y or N	Select Y to register items that subtract, rather than add to the sale total.
HASH	Y or N	Items designated with HASH status add to the current sale, but do not add to the registers grand total. HASH items may or may not add to the net sales total - see system option programming. Use hash for lottery sales or bottle deposits.
SINGLE ITEM	Y or N	Select Y for a single item PLU. Single item PLUs automatically total as a cash sale immediately after the PLU entry. Single item PLUs are used to speed up one item sales.
NON-ADD # COMP	Y or N	Select Y to enforce the entry of a non-add number before a registration can be made.

Option	Entry	Description
GALLONAGE ITEM	Y or N	Select Y to compute gallons sold. The gallons sold will print along with the price entry on the receipt. The total gallons sold will accumulate in the PLU counter. You must program the price per gallon (in tenths of a cent, i.e. \$1.299 for \$1.29 and 9/10) in the PRICE/HALO field.
INVENTORY ITEM	Y or N	Select Y if you wish to track the number of items remaining in inventory using the Stock report.
DISABLE	Y or N	Select Y to disable the PLU. Entries can not be made into disabled PLUs.
SCALEABLE	Y or N	If Y , the PLU will work only when you are multiplying a weight from an optional scale or when multiplying a manually entered weight. (For example, enter weight, press SCALE , then register PLU.)
AUTO SCALE	Y or N	Select Y if you wish entries into this PLU to be automatically multiplied by the weight on the optional scale
AUTO TARE (1-5)	0-5	Enter a value (1-5) to indicate the number of the preprogrammed tare weight you want to automatically subtract when the PLU is used for a scale entry (using an optional scale). Enter 0 to disable automatic tare subtraction.
CONDIMENT	Y or N	Select Y if you wish the item to act like a condiment on the kitchen printer. Items with this status will satisfy the requirements of items with compulsory condiment status.
COMPULSORY CONDMNT	Y or N	Select Y if you wish to force the entry of a condiment after this item is entered.
PRINT ON RECEIPT PRINT ON DISPLAY PRINT ON CHECK	Y or N	Select N if you wish to suppress printing (or display) of the item at the designated location.
PRT PRICE ON RCPT	Y or N	Select N if you wish to suppress printing of the item's price on the receipt.
PRT PRICE ON CHK	Y or N	Select N if you wish to suppress printing of the item's price on the check.
DISABLE PROMO	Y or N	Select Y to block the PROMO function on this PLU.
COUNTER NOT RESET	Y or N	Select Y if you do not wish to reset the PLU item counter on the Z PLU report.
PRESET OVERRIDE IN MGR CONTROL	Y or N	If preset override is Y , then you can force manager control for preset override by setting this option to Y .
LINK PLU	14 digit maximum	If you wish the registration of this PLU to automatically cause the registration of another PLU, enter the PLU # you wish to link with the 10-key pad. Enter 0 for no link.

Delete PLU

Note: To delete a PLU, all totals for the PLU must be cleared from Z reports (including Stock and PLU reports.)

1. From the **PLU PROGRAMMING** screen, press **1** to display the **DELETE PLU** screen:

```
DELETE PLU

0 . DELETE ONE PLU
1 . DELETE PLU RANGE
```

2. Press **0** to delete an individual PLU. The **PLU NUMBER** screen displays:

```
PLU NUMBER
* ENTER PLU NUMBER
AND PUSH PLU, OR
* PRESS A PLU KEY ON
THE KEYBOARD

0 ←
```

3. Enter the number of the PLU you wish to delete, or press a PLU key on the keyboard, or press modifier key followed by a the PLU key on the keyboard. The **CONFIRM DELETE** screen displays:

```
CONFIRM DELETE

ARE YOU SURE YOU
WISH TO DELETE PLU#
????????????????

ENTER=DELETE
ESC=ABORT
```

4. Press **ENTER** to delete the PLU; press **ESC** to return to the **PLU DELETE** screen without deleting the PLU.

Delete PLU Range

Note: To delete PLUs, all totals for the PLUs must be cleared from Z reports (including Stock and PLU reports.)

1. From the **PLU PROGRAMMING** screen, press **1** for to display the **DELETE PLU** screen:

```
DELETE PLU
0 . DELETE ONE PLU
1 . DELETE PLU RANGE
```

2. Press **1** to delete a range of PLUs. The **PLU NUMBER** screen displays:

```
PLU NUMBER
* ENTER NUMBER OF
  THE FIRST PLU IN
  THE RANGE AND PUSH
  PLU
0 ←
```

3. Enter the number of the first PLU in the range you wish to delete and press PLU. The screen prompts for the last PLU in the range:

```
PLU NUMBER
* ENTER NUMBER OF
  THE LAST PLU IN
  THE RANGE AND PUSH
  PLU
0 ←
```

4. Enter the number of the last PLU in the range you wish to delete and press **PLU**. The **CONFIRM DELETE** screen displays:

```
CONFIRM DELETE

ARE YOU SURE YOU
WISH TO DELETE PLU#
???????????????? TO
????????????????
ENTER=DELETE
ESC=ABORT
```

5. Press **ENTER** to delete the PLU; press **ESC** to return to the **PLU DELETE** screen without deleting the PLU.

Note: Before a PLU can be deleted, all report information must be cleared. It may be necessary to run a Z1 and Z2 PLU Report, and if the PLU is an inventory item, you must change the stock to zero.

Group Programming

Up to 99 groups (**the exact number is determined by memory allocation**) are available to summarize PLU sales. Group totals appear on reports, so that you can track sales of different types of items.

- ◆ The group descriptors programmed here will replace the default descriptors GROUP 1 through GROUP 99 that appear on reports.
- ◆ Each PLU can report totals to one, two or three different groups. If a PLU sends totals to more than one group, the group total that appears on the Group report will not represent PLU sales. Therefore, you also have the option of deciding whether each group's total will add to the group total on the Group report.

To Program Groups

1. At the **PGM** control lock position menu, press **1** for **GROUP**. The **GROUP PROGRAM** screen displays: (The maximum group number is set by memory allocation.)

```
GROUP PROGRAMMING
GROUP NO? (1-20)  0←
```

2. Enter the number of the group to be programmed, press **ENTER**. The **GROUP# PROG** screen displays:

```
GROUP #1 PROG.  ↓
DESC : GROUP 1   ←
ADD TO GROUP TTL  Y
SEND TO KP       N
KP PORT# : 1 2 R
              N N Y
PRINT RED ON KP  N
```

3. Press **PAGE DOWN** to view the second page of group programming:

GROUP #1 PROG.	↑
SEND TO KV	N←
KV GROUP# (0-8)	0
KV COLOR (0-8)	0
AGE VERIF. (0-5)	0

4. Refer to the table below to fill the fields of the **GROUP PROGRAMMING** screens.
5. Press **ENTER** to return to the **GROUP PROGRAMMING** screen. Continue to program groups as necessary. Press **ESC** to return to the **PROGRAM MODE** screen.

Group Programming - Reference Information

Option	Entry	Description
DESC	Alpha numeric 12 character	You can program a descriptor for each group. Type the descriptor using the Program Overlay or by using the descriptor code method (see page 117.). The overlay is automatically activated when the cursor is pointing at the DESC field. The default descriptors are GROUP 1, GROUP 2, etc.
ADD TO GROUP TOTAL	Y or N	Select N if you do not wish this groups total to be added to the total of all groups on the Group report.
SEND TO KP	Y or N	Select Y if you wish to send PLUs reporting to this group to a kitchen printer.
KP PORT #	Y or N	Select Y or N to direct items to a device attached to port 1 or port 2. At R , select Y or N to print a kitchen requisition at the register.
PRINT RED ON KP	Y or N	Select Y if you wish items reporting to this group to print in red on the kitchen printer. (Note, the kitchen printer must have red/black printing capability, and this option does not apply to the register receipt printer.)
SEND TO KV	Y or N	Not Used
KV GROUP#	0-8	Not Used
KV COLOR	0-8	Not Used
AGE VERIF.	0-5	When an item in this group is registered (first time in a transaction only), the register will prompt the operator to enter the customer's date of birth. The sale of the item will be registered only if the customer has reached the appropriate age. Set "0" for no age requirement. Set "1" to "5" to check the date of birth against the age requirement group set in Z Mode.

Sales Tax Programming

The *ER-650/650R* allows three calculation options for each of the four possible taxes.

- Add-On - most sales taxes can be programmed by entering an *add-on* tax percentage rate.
- Tax Table - if a tax entered as an add-on tax percentage does not follow exactly the tax chart follow that apply in your area, *tax table* programming will match tax collection exactly to the break points of your tax table. (Tax table programming allows up to 75 breakpoints.)
- VAT - if tax is included in the cost of the item, you can use value added tax (*VAT*) to calculate the tax share of each sale.
- A fourth tax programming option, for the Canadian Goods and Services tax (*GST*) can be set using tax rate 4.

Important Note: After you have entered your tax program, test for accuracy by entering several transactions of different dollar amounts. Carefully check to make sure the tax charged by the cash register matches the tax amounts on the printed tax chart for your area. As a merchant, you are responsible for accurate tax collection. If the cash register is not calculating tax accurately, or if you cannot program your tax properly from the information in this manual, contact your Dealer for assistance.

Programming an Add-On Tax Rate Percentage

When tax requirements can be met using a straight percentage rate, use the following method to program a tax as a straight percentage.

1. Turn the control lock to the **PGM** position.
2. From the **PROGRAM MODE** menu, press **2** to view the **TAX PROG.** screen:

```
TAX PROG .
TAX NUMBER (1-4)  1←
TAX TYPE (0-2)   0
0 : ADD-ON
1 : TAX TABLE
2 : VAT
```

3. When the arrow is pointed at the **TAX NUMBER** field, enter the number of the tax you wish to program. (There are four taxes available, enter **1**, **2**, **3**, or **4**.) The arrow will move to the **TAX TYPE** field.
4. Enter **0** for an **ADD-ON** tax with a straight percentage rate. The appropriate **TAX # PROGRAMMING** screen displays:

```
TAX #1 PROGRAMMING
TAX RATE          0.000←
```

5. When the arrow is pointed at the **TAX RATE** field, enter the percentage rate for the sales tax. For example if the tax is 6 percent, enter **6.000** or **6.0**. If the tax is 7.5 percent, enter **7.500** or **7.5** using the decimal key. If the tax is 10 percent, enter **10.000** or **10.0**. Press **ENTER (CASH)** to set the rate.
6. The **TAX PROG.** screen will return prompting you to enter the next tax, if necessary. Continue to program additional taxes or press **CLEAR** to return to the **PROGRAM MODE** screen.

Programming a Tax Table

In some cases, a tax that is entered as a percentage does not exactly follow the tax charts that apply in your area (even if the tax chart is based on a percentage). In these cases, we recommend that you enter your tax using tax table programming. This method will match tax collection exactly to the break points of your tax table.

Before programming, obtain a copy of the tax table you wish to program. You will need the printed tax table if you wish to determine the break point entries yourself. The "Tax Table Programming Example - Illinois 6% Tax Table" on page 139 is used as an example in the steps that follow.

Note: You can enter up to 75 break points.

1. Turn the control lock to the **PGM** position.
2. From the **PROGRAM MODE** menu, press **2** to view the **TAX PROG.** screen:

```
TAX PROG .
TAX NUMBER (1-4)  1 ←
TAX TYPE (0-2)   1
  0 : ADD-ON
  1 : TAX TABLE
  2 : VAT
```

3. When the arrow is pointed at the **TAX NUMBER** field, enter the number of the tax you wish to program. (There are four taxes available, enter **1**, **2**, **3**, or **4**.) The arrow will move to the **TAX TYPE** field.
4. Enter **1** for an **TAX TABLE** programming. The appropriate **TAX # PROGRAMMING** screen displays:

```
TAX #1 PROGRAMMING
FIRST TAX AMOUNT
                                0.01 ←
NON-TAXable AMOUNT
                                0.10
# OF NON-REPEAT
BREAK                            5
# OF REPEAT BRK                   3
```

5. Use the table below as a guide in filling the fields on this screen. After completing these entries, your screen should look like the screen that follows.

Field	Description
FIRST TAX AMOUNT	Enter the first tax amount that is charged. For this example the entry is 0.01.
NON-TAXable AMOUNT	Enter the highest amount where no tax is charged. For this example the entry is 0.10.
# OF NON-REPEAT BRK	Enter the number of Non-repeat breaks. For this example the entry is 5.
# OF REPEAT BREAK	Enter the number of repeat breaks. For this example the entry is 3.

6. After entering the **# OF REPEAT BRK** field, the next **TAX TABLE PROG.** screen will display. Using the printed copy of your tax table, enter information in the **SALE AMOUNT RANGE** fields. Enter the information as it appears on your tax table. Enter the high amount of the first range where you are prompted. The low amount of the next range will be computed automatically. After completing the tax range entries, your screen should look like the following screen. Note that this screen should look exactly like the corresponding part of the printed tax table.

TAX TABLE PROG.		
TAX	SALE AMT	RANGE
0.00	0.00	0.10
0.01	0.11	0.21
0.02	0.22	0.38
0.03	0.39	0.56
0.04	0.57	0.73
0.05	0.74	0.91 ←

7. Because this tax table has more than 5 break points (the number of break points that can be displayed on the first screen), you must continue to enter **SALE AMT RANGE** information on the additional screens until information has been entered for each break point. After completing the tax range entries, your screen should look like the following screen. Note that this screen should look exactly like the corresponding part of the printed tax table.

TAX TABLE PROG.			
TAX	SALE	AMT	RANGE
0.06	0.92	1.08	
0.07	1.09	1.24	
0.08	1.25	1.41	←

8. After you have completed entering the **SALES AMOUNT RANGE** information, the **TAX PROG.** screen will return, prompting you to enter the next tax, if necessary. Continue to program additional taxes or press **CLEAR** to return to the **PROGRAM MODE** screen.

Note: Some tax tables are very complex. Contact your Dealer for assistance should you have difficulty entering your Tax Table.

Tax Table Programming Example - Illinois 6% Tax Table

1. Examine the printed tax table for the tax you are programming.
2. Calculate the break point differences by subtracting the high side of the previous range from the high side of the sale amount range.
3. Examine the pattern of break point differences to determine when the break points begin to repeat. Mark the beginning break points that do not fit a pattern as “non-repeat breaks.” Mark the break points that are repeating in a pattern as “repeat breaks.” Count the number of repeat and non-repeat breaks.

<u>Tax Charged</u>	<u>Sale Amount Range</u>	<u>Break point Differences</u>	
\$0.00	\$0.00 - \$0.10		
\$0.01	\$0.11 - \$0.21	11	Non-Repeat
\$0.02	\$0.22 - \$0.38	17	
\$0.03	\$0.39 - \$0.56	18	
\$0.04	\$0.57 - \$0.73	17	
\$0.05	\$0.74 - \$0.91	18	
\$0.06	\$0.92 - \$1.08	17	Repeat
\$0.07	\$1.09 - \$1.24	16	
\$0.08	\$1.25 - \$1.41	17	
\$0.09	\$1.42 - \$1.58	17	
\$0.10	\$1.59 - \$1.74	16	
\$0.11	\$1.75 - \$1.91	17	
\$0.12	\$1.92 - \$2.08	17	
\$0.13	\$2.09 - \$2.24	16	
\$0.14	\$2.25 - \$2.41	17	

Programming a VAT (Value Added Tax)

When a tax is included in the cost of the item, you can use the value added tax (VAT) program to calculate the tax share of each sale.

1. Turn the control lock to the **PGM** position.
2. From the **PROGRAM MODE** menu, press **2** to view the **TAX PROG.** screen:

```
TAX PROG .
TAX NUMBER (1-4)  1 ←
TAX TYPE (0-2)    0
0 : ADD-ON
1 : TAX TABLE
2 : VAT
```

3. When the arrow is pointed at the **TAX NUMBER** field, enter the number of the tax you wish to program. (There are four taxes available, enter **1**, **2**, **3**, or **4**.) The arrow will move to the **TAX TYPE** field.
4. Enter **2** for **VAT**. The appropriate **TAX # PROGRAMMING** screen displays:

```
TAX #1 PROGRAMMING
TAX RATE          0.000 ←
```

5. When the arrow is pointed at the **TAX RATE** field, enter the VAT rate. For example if the tax is 6 percent, enter **6.000** or **6.0**. If the tax is 7.5 percent, enter **7.500** or **7.5** using the decimal key. If the tax is 10 percent, enter **10.000** or **10**. Press **ENTER (CASH)** to set the rate.
6. The **TAX PROG.** screen will return, prompting you to enter the next tax, if necessary. Continue to program additional taxes or press **CLEAR** to return to the **PROGRAM MODE** screen.

Programming a Canadian GST

Tax 4 can be programmed to accommodate the Canadian Goods and Services tax (GST).

1. Turn the control lock to the **PGM** position.
2. From the **PROGRAM MODE** menu, press **2** to view the **TAX PROG.** screen:

```
TAX PROG .
TAX NUMBER (1-4) 4←
TAX TYPE (0-2) 0
0 : ADD-ON
1 : TAX TABLE
2 : VAT
```

3. When the arrow is pointed at the **TAX NUMBER** field, enter **4**, press **ENTER (CASH)**. The arrow will move to the **TAX TYPE** field.
4. Press **ENTER (CASH)**. The **TAX #4 PROGRAMMING** screen displays:

```
TAX #4 PROGRAMMING
TAX RATE 0.000←
GST IS TAXABLE BY
RATE 1 N
RATE 2 N
RATE 3 N
```

5. When the arrow is pointed at the **TAX RATE** field, enter the GST rate. For example if the tax is 6 percent, enter **6.000** or **6.0**. If the tax is 7.5 percent, enter **7.500** or **7.5** using the decimal key. If the tax is 10 percent, enter **10.000** or **10.0**. Press **ENTER (CASH)** to set the rate.
6. At the **RATE 1** field, indicate if the GST is taxable by rate 1 (tax on tax) by pressing the **YES/NO** key, then pressing the **ENTER (CASH)** key. The arrow advances to the **RATE 2** field. Enter taxable status for **RATE 2** and **RATE 3**. The **PROGRAM MODE** screen returns.

System Option Programming

1. At the **PGM** control lock position menu, press **3** for **SYSTEM OPTION** Programming. The **SYSTEM OPTION pg 1** screen displays:
2. Refer to "System Options - Reference Information" on page 146 to make program entries or changes, press the **ENTER** key to finalize.

The 1st System Option screen. →

```

SYSTEM OPTION pg 1
BEEPER ACTIVE      Y←
REAL CLERK KEY    N
CLERK ENTRY       0
  0:PUSH 1:CODE
CLERK ASSIGNED WHEN
CLERK KEY IS
PUSHED (1-10)     1
    
```

Press **ENTER** after making a change, or press **ENTER** to advance the arrow to the next option without making a change.

Press **PAGE DOWN** to view the 2nd System Option screen. →

```

SYSTEM OPTION pg 2
CLERK IS Y:POP-UP N←
      N:STAY-DOWN
DRAWER NEEDS TO BE
SHUT TO OPERATE  Y
ACTIVATE OPEN
DRAWER ALARM     N
    
```

Press **PAGE UP** to return to the previous screen.

Press **PAGE DOWN** to view the 3rd System Option screen. →

```

SYSTEM OPTION pg 3
SECONDS TO ALLOW
DRAWER OPEN      30←
ALLOW POST TENDER N
OPEN DRAWER ON
POST TENDER      Y
ALLOW MULTIPLE
RECEIPT          N
    
```

NOTE:
Be sure to press **ENTER** after changing a selection. If you do not press **ENTER**, the change will not be accepted.

Press **PAGE DOWN** to view the 4th System Option screen. →

```

SYSTEM OPTION pg 4
CASH DECLARATION REQ
BEFORE REPORTS    N←
MGR CONTROL TO TEND.
NEGATIVE BALANCE N
ZERO BALANCE      N
RESET TRANSACTION
NO. ON Z REPORT  N
    
```

Press **YES/NO** to toggle from 'Y' to 'N' for yes or no decisions.

Press
PAGE DOWN
to view the 5th
System Option
screen.

```
SYSTEM OPTION pg 5
RESET GRAND TOTAL
AFTER Z REPORT N←
OPEN DRAWER WHEN
REPORTS ARE RUN Y
OPEN DRAWER DURING
TRAIN MODE N
DECIMAL PLACE 2
```

Press **ENTER**
after making a
change, or press
ENTER to
advance the
arrow to the
next option
without making
a change.

Press
PAGE DOWN
to view the 6th
System Option
screen.

```
SYSTEM OPTION pg 6
DATE FORMAT IS 0←
0:MDY 1:DMY 2:YMD
MODIFIER 0
0:POP UP AFTER ITEM
1:POP UP AFTER SALE
2:STAYDOWN
```

Press **PAGE UP**
to return to the
previous screen.

Press
PAGE DOWN
to view the 7th
System Option
screen.

```
SYSTEM OPTION pg 7
% AND TAX CAL. 0←
SPLIT PRICE CAL. 0

CALCULATION CHART
0:ROUND UP AT 0.50
1:ROUND UP
2:ROUND DOWN
```

NOTE:
Be sure to press
ENTER after
changing a
selection. If you
do not press
ENTER, the
change will not
be accepted.

Press
PAGE DOWN
to view the 8th
System Option
screen.

```
SYSTEM OPTION pg 8
COMPULSORY EAT-IN
T-OUT D-THRU BEFORE
TENDERING N←
HASH IS Y
Y:NORMAL N:NON-ADD
ALLOW PRINT SCREEN
ON @/FOR KEY Y
```

Press **YES/NO**
to toggle from
'Y' to 'N' for yes
or no decisions.

Press
PAGE DOWN
to view the 9th
System Option
screen.

```
SYSTEM OPTION pg 9
RESET Z COUNTER
AFTER Z1 REPORT
FINANCIAL REPORT N←
TIME REPORT N
PLU REPORT N
CLERK REPORT N
GROUP REPORT N
```

Press
PAGE DOWN
to view the 10th
System Option
screen.

```

SYSTEM OPTION pg 10
RESET Z COUNTER
  AFTER Z2 REPORT
DAILY SALES RPT  N←
PRINTER PAPER
SENSOR ACTIVE    Y
DEACTIVATE SPLIT
PRICING          N
  
```

Press **ENTER**
after making a
change, or press
ENTER to
advance the
arrow to the
next option
without making
a change.

Press
PAGE DOWN
to view the 11th
System Option
screen.

```

SYSTEM OPTION pg 11
ALLOW DIRECT MULT N←
INVENTORY CNT PGM N
Y:ADD CURR. LVL
N:COUNTER REPLACE
  CURR. LVL
GLOBAL ENTRY LIMIT
(0-14)          0
  
```

Press **PAGE UP**
to return to the
previous screen.

Press
PAGE DOWN
to view the 12th
System Option
screen.

```

SYSTEM OPTION pg 12
DISABLE PRICE LEVEL
  KEY
LEVEL 1:          N←
LEVEL 2:          N
LEVEL 3:          N
LEVEL 4:          N
LEVEL 5:          N
  
```

NOTE:
Be sure to press
ENTER after
changing a
selection. If you
do not press
ENTER, the
change will not
be accepted.

Press
PAGE DOWN
to view the 13th
System Option
screen.

```

SYSTEM OPTION pg 13
PRICE LEVEL IS    0←
0:POP UP AFTER ITEM
1:POP UP AFTER SALE
2:STAYDOWN

ELECT. JOURNAL   N
  
```

Press
PAGE DOWN
to view the 14th
System Option
screen.

```

SYSTEM OPTION pg 14
PROMPT OPERATOR WHEN
EJ BUFF. IS FULL Y
STOP OPERATIONS WHEN
EJ BUFF. IS FULL N
SEND ONLY NEGATIVE
ENTRIES TO EJ    N
  
```

Press
PAGE DOWN
to view the 15th
System Option
screen.

```
SYSTEM OPTION pg 15
SEND RESET REPORT
TO EJ N←
DIRECT MULT MORE
THAN ONE DIGIT N
TENDER VALICATION N
Y:AMT TENDERED
N:AMT OF SALE
```

Press **ENTER**
after making a
change, or press
ENTER to
advance the
arrow to the
next option
without making
a change.

Press
PAGE DOWN
to view the 16th
System Option
screen.

```
SYSTEM OPTION pg 16
ALLOW PRICE LEVEL N←
ONLY MGR MODE
EMBEDDED PRICE BAR 0
CODE TYPE 1/3/7
DISPLAY ADD PRICE N
OF LINKED ITEMS
```

Press **PAGE UP**
to return to the
previous screen.

NOTE:
Be sure to press
ENTER after
changing a
selection. If you
do not press
ENTER, the
change will not
be accepted.

Press
PAGE DOWN
to view the 17th
System Option
screen.

```
SYSTEM OPTION pg 17
ALLOW SALE Y←
WITH 0 STOCK
ALLOW SWEDISH ROUND
ON SUBT N
ON CASH N
ALLOW Z STOCK RPT Y
PRG DESC BY CODE N
```

System Options - Reference Information

Option	Entry	Description
BEEPER ACTIVE	Y or N	Select N for a silent keyboard.
REAL CLERK KEY	Y or N	Select Y if the optional bayonet clerk lock and key system is installed.
CLERK ENTRY 0:PUSH 1:CODE	0 or 1	Select PUSH for a push button clerk, select CODE for a code entry clerk system (number - clerk or clerk - number - clerk) sequence.
CLERK ASSIGNED WHEN CLERK KEY IS PUSHED (1-10)	1-10	If PUSH system is selected, you can select the clerk that is signed on when the CLERK # key is pressed. Note that the maximum clerk number you can enter here is determined by how many clerks are allocated in memory.
CLERK IS Y:POP-UP N:STAY-DOWN	Y or N	Select Y for pop-up clerks, select N for stay down clerks. With pop-up clerks, you must sign on for each transaction. With stay down clerks, the same clerk remains signed on until sign off.
DRAWER NEEDS TO BE SHUT TO OPERATE	Y or N	Select Y to enforce closed drawer for register operations.
ACTIVATE OPEN DRAWER ALARM	Y or N	Select Y if you want the error tone to automatically sound when the drawer stays open longer than the time set in the following field.
SECONDS TO ALLOW DRAWER OPEN	1-99	If you enable the open drawer alarm above, you can set the length of time (1-99 seconds) before the alarm sounds.
ALLOW POST TENDER	Y or N	Select Y to allow re-tendering should a second change calculation be necessary. Re-enter the tendered amount and press the CASH key to show the new change computation.
OPEN DRAWER ON POST TENDER	Y or N	If you enable post tendering, select N to not open the cash drawer after the second tender.
ALLOW MULTIPLE RECEIPT	Y or N	Set to Y if you wish to issue more than one copy of a transaction receipt.
CASH DECLARATION REQ BEFORE REPORTS	Y or N	Select Y to enforce a cash declaration function before a financial, clerk, or cash in drawer report can be generated.
MGR CONTROL TO TEND. NEGATIVE BALANCE ZERO BALANCE	Y or N	Select Y if you wish to control negative transactions (when cash is removed from the drawer). When selected the control lock must be in the X position to finalize the transaction.
RESET TRANSACTION # ON Z REPORT	Y or N	Select Y if you wish to reset the transaction number (often called the receipt counter) to zero after the financial report is reset.
RESET GRAND TOTAL AFTER Z REPORT	Y or N	Select Y if you wish to reset the grand total to zero after the financial report is reset.
OPEN DRAWER WHEN REPORTS ARE RUN	Y or N	Select N to stop the drawer from opening when reports are run.

Option	Entry	Description
OPEN DRAWER DURING TRAIN MODE	Y or N	Select N if you do not want the cash drawer to open during training mode operations.
DECIMAL PLACE	0, 1, 2, 3, or 4	Enter a digit to place the decimal point the selected number of positions from the right.
DATE FORMAT IS 0:MDY 1:DMY 2:YMD	0, 1, or 2	Select 0 for MMDDYY, select 1 for DDMMYY, or select 2 for YYMMDD date printing format.
MODIFIER: 0:POP UP AFTER ITEM 1:POP UP AFTER SALE 2:STAYDOWN	0, 1, or 2	A MODIFIER key alters the next PLU registered, either by changing the code number of the PLU so that a different item is registered, or by adding the modifier descriptor and not changing the code of the subsequent PLU. If you press a modifier key, you have the option of the modifier applying only to the next item (0), having the same modifier apply to any subsequent item registered in the same transaction (1), or having the same modifier apply to any subsequent item on any subsequent transaction (2).
% AND TAX CAL.	0, 1, or 2	Select the digit that represents the appropriate rounding method for tax and discount calculations: 0 for round up at 0.5 of a penny (0.005), 1 for always round up or 2 for always round down.
SPLIT PRICE CAL.	0, 1, or 2	Select the digit that represents the appropriate rounding method for split pricing (i.e. 2 at 3 for \$1.00) calculations: 0 for round up at 0.5 of a penny (0.005), 1 for always round up or 2 for always round down.
COMPULSORY EAT-IN T-OUT D-THRU BEFORE TENDERING	Y or N	Choose Y if you wish to enforce use of one of the destination keys (EAT-IN, TAKE OUT, or DRIVE THRU) before the sale is finalized.
HASH IS Y:NORMAL N:NON-ADD	Y or N	Y : Hash adds to all totals except the gross and net sales totals on the financial report. N : Hash does not add to any totals, except the HASH total on the financial report.
ALLOW PRINT SCREEN ON @/FOR KEY	Y or N	Choose N if you wish to disable the print screen function of the @/ FOR key.
RESET Z COUNTER AFTER Z1 REPORT FINANCIAL REPORT TIME REPORT PLU REPORT CLERK REPORT GROUP REPORT	Y or N	Choose Y or N to determine if you wish to reset the Z counter after a Z1 of each report listed.
RESET Z COUNTER AFTER Z2 REPORT DAILY SALES RPT	Y or N	Choose Y or N to determine if you wish to reset the Z counter after a Z2 of the daily sales report.
PRINTER PAPER SENSOR ACTIVE	Y or N	A built in paper sensor determines whether paper is currently loaded in the printer. If Y , operations are not allowed without paper loaded. If N , operations are allowed when paper is out.

Option	Entry	Description
DEACTIVATE SPLIT PRICING	Y or N	If N , both multiplication and split pricing calculations can be done with the @/FOR key. If Y , only multiplication can be done with the @/FOR key.
ALLOW DIRECT MULT	Y or N	If Y , you can multiply preset items by simply entering the quantity, then pressing the preset PLU key.
INVENTORY CNT PGM Y:ADD CURR. LVL N:COUNTER REPLACE CURR LEVEL	Y or N	Choose Y or N to determine whether the quantity of inventory you enter in the PLU stock program adds to existing inventory quantity, or whether it replaces the current inventory quantity.
GLOBAL ENTRY LIMIT (0-14)	0-14	Enter a digit to determine the number of numeric digits that can be entered for any register function. Enter 0 for no limit.
DISABLE PRICE LEVEL KEY LEVEL 1: LEVEL 2: LEVEL 3: LEVEL 4: LEVEL 5:	Y or N	You can choose to disable any of the price level keys here.
PRICE LEVEL IS 0:POP UP AFTER ITEM 1:POP UP AFTER SALE 2:STAYDOWN	0, 1, or 2	If you press a price level key, you have the option of the level key applying only to the next item (0), having the same level key apply to any subsequent item registered in the same transaction (1), or having the same level key apply to any subsequent item on any subsequent transaction(2).
ELEC. JOURNAL	Y or N	Select Y to enable the electronic journal. The electronic journal captures in memory what you would print line by line on a traditional journal. The four options that follow control the electronic journal feature. The electronic journal can be read and printed in the X control lock position or reset and printed in the Z control lock position.
PROMPT OPERATOR WHEN E.J. IS FULL	Y or N	If the electronic journal is enabled above, select Y if you wish to display a message to notify the operator when the journal memory is full.
STOP OPERATIONS WHEN E.J. IS FULL	Y or N	If the electronic journal is enabled above, select Y if you wish to stop operations when the journal memory is full.
SEND ONLY NEGATIVE ENTRIES TO E.J.	Y or N	If the electronic journal is enabled above, select Y if you wish to capture only transactions with negative entries.
SEND RESET REPORT TO E.J	Y or N	If the electronic journal is enabled above, select Y if you wish to capture reset reports.
DIRECT MULT MORE THAN ONE DIGIT	Y or N	If you allow direct multiplication of a preset PLU, you can allow only single digit multiplication or multiplication by more than one digit.
TENDER VALIDATION Y:AMT TENDERED N:AMT OF SALE	Y or N	Validation is allowed if an appropriate optional printer is connected to an RS-232C port. Here you can choose the content of single line validation
ALLOW PRICE LEVEL ONLY MGR MODE	Y or N	Choose Y to require the X Mode key to operate the Price Level keys.

Option	Entry	Description
EMBEDED PRICE BAR CODE TYPE 1/3/7	1, 3, or 7	Enables price embedded bar codes: 1 = Type 1 embedded bar codes with a price check sum. 3 = Type 3 embedded bar codes without a check sum. 7 = Choose 7 if you are embedding a weight, rather than a price. Use weight when different items are sold in bulk, such as nut/bolts in a hardware store. When a weight embedded bar code is scanned the weight is displayed and must be extended by a price at the cash register.
DISPLAY ADD PRICE OF LINKED ITEMS	Y or N	When Y, the customer display shows a total of the item and linked item. For example, if PLU is \$1.00 and is linked to PLU2 which is \$0.25, the customer display will show \$1.25.
ALLOW SALE WITH 0 STOCK	Y or N	When N, inventory PLUs cannot be sold when stock reaches "0".
ALLOW SWEDISH ROUND ON SUBT ON CASH	Y or N	Swedish rounding rounds as below: .00 - .02 = .00 .03 - .07 = .05 .08 - .09 = .10
ALLOW Z STOCK RPT	Y or N	When N, the operator is not allowed to clear (Z) stock.
PRG DESC BY CODE	Y or N	When N, program descriptors by pressing the appropriate key on the program overlay. When Y, program descriptors by typing the code for each descriptor character.

Print Option Programming

1. At the **PGM** control lock position menu, press **4** for **PRINT OPTION** Programming. The **PRINT OPTION pg 1** displays:
2. Refer to "Print Options – Reference Information" on page 153 to make program entries or changes, press the **ENTER** key to finalize.

The 1st Print Option screen.

```

PRINT OPTION pg 1
PRINT MEDIA TOTALS
ON CLERK REPORT N←
PRINT TAX SYMBOL Y
PRINT VD MODE AND
RETURN ON REPORT Y
PRINT AUDACTION
ON REPORT N
    
```

Press **ENTER** after making a change, or press **ENTER** to advance the arrow to the next option without making a change.

Press **PAGE DOWN** to view the 2nd Print Option screen.

```

PRINT OPTION pg 2
SKIP ZERO TOTALS ON
FINANCIAL REPORT Y←
SKIP ZERO TOTALS ON
CLERK REPORT Y
PRT CLERK RPT AFT
FINANCIAL RPT N
PRT SALE ITEM NO. N
    
```

Press **PAGE UP** to return to the previous screen.

Press **PAGE DOWN** to view the 3rd Print Option screen.

```

PRINT OPTION pg 3
PRINT PLU WITH ZERO
TOTALS ON REPORT N←
PRINT SUBTOTAL WHEN
PRESSED N
PRINT % OF SALES
ON PLU REPORT N
PRINT CONS. NO. Y
    
```

NOTE:
Be sure to press **ENTER** after changing a selection. If you do not press **ENTER**, the change will not be accepted.

Press **PAGE DOWN** to view the 4th Print Option screen.

```

PRINT OPTION pg 4
PRINT DATE Y←
PRINT TIME Y
PRINT MACHINE NO. Y
PRINT CLERK NAME Y
HOME CURRENCY
SYMBOL IS $
PRINT Z COUNTER Y
    
```

Press **YES/NO** to toggle from 'Y' to 'N' for yes or no decisions.

Press
PAGE DOWN
to view the 5th
Print Option
screen.

```
PRINT OPTION pg 5
PRINT RECEIPT WHEN
SIGN ON/OFF      Y ←
PRINT GRAND TOTAL
ON X REPORT      Y
ON Z REPORT      Y
```

Press **ENTER**
after making a
change, or press
ENTER to
advance the
arrow to the
next option
without making
a change.

Press
PAGE DOWN
to view the 6th
Print Option
screen.

```
PRINT OPTION pg 6
PRINT GROSS TOTAL
ON X REPORT      Y ←
ON Z REPORT      Y
PRINT SUBTOTAL W/O
TAX              N
TAX AMOUNT IS   N
Y:COMBINE N:ITEMIZE
```

Press **PAGE UP**
to return to the
previous screen.

NOTE:
Be sure to press
ENTER after
changing a
selection. If you
do not press
ENTER, the
change will not
be accepted.

Press
PAGE DOWN
to view the 7th
Print Option
screen.

```
PRINT OPTION pg 7
PRINT TAX AMOUNT Y ←
PRT TAXABLE TOTAL N
PRINT TAX % RATE  N
VAT BREAKDOWN    N
PRT TRAIN MODE TITLE
IN TRAINING MODE N
```

Press **YES/NO**
to toggle from
'Y' to 'N' for yes
or no decisions.

Press
PAGE DOWN
to view the 8th
Print Option
screen.

```
PRINT OPTION pg 8
CURRENCY SYMBOL
CONV#1           . ←
CONV#2           .
CONV#3           .
CONV#4           .
```

Press
PAGE DOWN
to view the 9th
Print Option
screen.

```
PRINT OPTION pg 9
PRT KP ORDER # ON
RECEIPT Y←
PRINT PRICE ON KP N
SEND TO KP IN
VOID MODE Y
SEND TO KP IN
TRAIN MODE N
```

Press **ENTER**
after making a
change, or press
ENTER to
advance the
arrow to the
next option
without making
a change.

Press
PAGE DOWN
to view the 10th
Print Option
screen.

```
PRINT OPTION pg 10
COMBINE LIKE ITEMS
ON KP N←
CONSOLIDATION ON
CHECK TRACK N
VOLUME UNIT 0
0:GAL 1:LTR
```

Press **PAGE UP**
to return to the
previous screen.

Press
PAGE DOWN
to view the 11th
Print Option
screen.

```
PRINT OPTION pg 11
PRINT PREAMBLE Y←
PRINT POSTAMBLE Y
MSG ON RECEIPT
PRINT PREAMBLE N
PRINT POSTAMBLE N
ON THE GUEST CHECK
```

Press
PAGE DOWN
to view the 12th
Print Option
screen.

```
PRINT OPTION pg 12
PRINT ON FIN RPT
AVG ITEM/CUST Y
AVG $/CUST Y
BUFFER RECEIPT ISSUE
WHEN REC IS ON N
PRIORITY PRINT BY
GROUP ON KP/KV N←
```

Press
PAGE DOWN
to view the 13th
Print Option
screen.

```
PRINT OPTION pg 13
PRINT PLU#
ON RECEIPT Y
E.J PORT (0/1/2) 0
REPORT PORT(0/1/2)0
PRINT E.J FROM N
Y:OLDEST N:NEWEST
```

Press
PAGE DOWN
to view the 14th
Print Option
screen.

```
PRINT OPTION pg 14
NOT PRINT WHEN  N←
POLLING REPORTS
PRINT PLU#      N
ON PLU REPORT
GRAND TOTAL IS  N
Y:NET  N:GROSS
```

Press **ENTER**
after making a
change, or press
ENTER to
advance the
arrow to the
next option
without making
a change.

Press
PAGE DOWN
to view the 15th
Print Option
screen.

```
PRINT OPTION pg 15
SEND ORDER TO KP  N←
AT SUBTOTAL
PRINT DATE ON     N
SERV ON HARD CHECK
```

Press **PAGE UP**
to return to the
previous screen.

Print Options - Reference Information

Option	Entry	Description
PRINT MEDIA TOTALS ON CLERK REPORT	Y or N	Select Y to print media totals for each clerk, thus allowing clerk cash drawer accountability.
PRINT TAX SYMBOL	Y or N	Select N to remove the tax symbol (i.e."T1") from the print and display.
PRINT VD MODE AND RETURN ON REPORT	Y or N	Select N to remove the VOID MODE and RETURN totals from the financial and clerk reports.
PRINT AUDACTION ON REPORT	Y or N	Select N to remove the AUDACTION total from the financial and clerk reports.
SKIP ZERO TOTALS ON FINANCIAL REPORT	Y or N	By default, the register prints only totals with information other than zero. Select N , if you wish to print the contents of all the financial report totals, even if the total is zero.
SKIP ZERO TOTALS ON CLERK REPORT	Y or N	By default, the register prints only totals with information other than zero. Select N , if you wish to print the contents of all the clerk report totals, even if the total is zero.
PRT CLERK REPORT AFT FINANCIAL RPT	Y or N	Select Y if you wish to include the clerk report information at the end of the financial report.
PRINT PLU WITH ZERO TOTALS ON REPORT	Y or N	By default, the register prints only totals with information other than zero. Select Y , if you wish to print the contents of all the PLUs, even if the total is zero.
PRINT SUBTOTAL WHEN PRESSED	Y or N	Select Y if you wish the subtotal to print when the SBTL key is pressed.
PRINT % OF SALES ON PLU REPORT	Y or N	The register can calculate the percentage of sales represented by each PLU. Select Y if you wish to print this percentage on the PLU report. Note: the percentage will print only on standalone register reports, not IRC report.
PRINT CONS. NO.	Y or N	The consecutive number (also referred to as the transaction counter, or receipt counter) normally prints on each receipt. Select N if you do not wish to print this counter.
PRINT DATE	Y or N	Select N if you wish to delete the printing of the date.
PRINT TIME	Y or N	Select N if you wish to delete the printing of the time.
PRINT MACHINE NO.	Y or N	If you are using more than one cash register, you can identify the specific register where a receipt was printed. Enter Y if you wish to print the register number on the receipt.
PRINT CLERK NAME	Y or N	Select N if you wish to delete the printing of the clerk name on the receipt.
HOME CURRENCY SYM	\$	Users outside of the USA can designate a different currency symbol. To select a different symbol, press the symbol you wish to use on the Alpha Keyboard overlay. When this field is selected, press 00 to display a list of optional symbols.
PRINT Z COUNTER	Y or N	Select N if you wish to delete the printing of the reset counter on Z reports.

Option	Entry	Description
PRINT RECEIPT WHEN SIGN ON/OFF	Y or N	Select N if you do not wish to print a receipt when signing on or off a clerk.
PRINT GRAND TOTAL ON X REPORT ON Z REPORT	Y or N	Select N if you wish to delete the printing of the grand total on the financial report reading (X report) or financial report resetting (Z report).
PRINT GROSS TOTAL ON X REPORT ON Z REPORT	Y or N	Select N if you wish to delete the printing of the gross sales total on the financial report reading (X report) or financial report resetting (Z report).
PRINT SUBTOTAL W/O TAX	Y or N	If you hand-write credit card slips, you may find it useful to print the merchandise subtotal. Select Y if you wish to print the subtotal without tax on the receipt.
TAX AMOUNT IS Y:COMBINE N:ITEMIZE	Y or N	Select Y if you are calculating and reporting more than one sales tax rate separately and you wish to print just the total of multiple taxes rather than itemize each tax on the receipt.
PRINT TAX AMOUNT	Y or N	Select Y if you wish to delete the printing of the tax amount on the receipt.
PRINT TAXABLE TOTAL	Y or N	Select Y if you wish to print the total of merchandise eligible for each tax on the receipt.
PRINT TAX % RATE	Y or N	If you are calculating a tax percentage (add-on or VAT), select Y if you wish to print the tax rate on each receipt.
VAT BREAKDOWN	Y or N	If Y, a breakdown of the VAT eligible sale will print, the net amount and the VAT amount.
INCLUDE VAT TAX IN TAX AMT	Y or N	Choose Y to print the VAT tax amount on the receipt, and include the VAT tax amount with other taxes, if applicable.
PRINT TRAIN MODE TITLE IN TRAIN MODE	Y or N	When in training mode, the message "TRAIN MODE" normally prints on each receipt. Select N if you wish to delete this message.
CURRENCY SYMBOL CONV.#1 CONV.#2 CONV.#3 CONV.#4	Y or N	If you are using the currency conversion feature, you can select the appropriate symbol for each foreign currency you are accepting. To select a different symbol, press the symbol you wish to use on the Alpha Keyboard overlay. When one of these fields are selected, press 00 to display a list of optional symbols.
PRINT KP ORDER # ON RECEIPT	Y or N	A system wide counter creates an order number for each kitchen requisition. Choose Y or N to print the order number on the kitchen printer requisition.
PRINT PRICE ON KP	Y or N	You can choose to print the item with or without its price on the kitchen requisition.
SEND TO KP IN VOID MODE	Y or N	You can choose whether to print or not print registrations in void mode on kitchen requisitions.
SEND TO KP IN TRAIN MODE	Y or N	You can choose whether to print or not print registrations in training mode on kitchen requisitions.

Option	Entry	Description
COMBINE LIKE ITEMS ON KP	Y or N	If two of the same items are registered in the same transaction, you can choose the format on the kitchen requisition. For example, if Y, "2 HAMBURGERS"; if N, "1 HAMBURGER" and "1 HAMBURGER".
CONSOLIDATION ON CHECK TRACK	Y or N	Consolidation of like items can be selected for soft guest check printing. For example, if three rounds of drinks are served, the check will print "3 TAP BEER" rather than "1 TAP BEER" three times.
VOLUME UNIT 0:GAL 1:LTR	0 or 1	If gallonage is selected in PLU programming, choose gallons or liters here.
PRINT PREAMBLE	Y or N	Choose whether to print the PREAMBLE on the receipt.
PRINT POSTAMBLE MESG ON RECEIPT	Y or N	Choose whether to print the POSTAMBLE on the receipt.
PRINT PREAMBLE	Y or N	Choose whether to print the PREAMBLE on the guest check.
PRINT POSTAMBLE ON THE GUEST CHECK	Y or N	Choose whether to print the POSTAMBLE on the guest check.
PRINT ON FIN RPT AVG ITEM/CUST AVG \$/CUST	Y or N	Choose whether to print the average items per customer (PLU sales counter/Net sales counter) or the average sales per customer (Net Sales/Net Sales counter).
BUFFER RECEIPT ISSUE WHEN REC IN ON	Y or N	Determine whether you can issue a second receipt for the same transaction with the CASH key
PRIORITY PRINT BY GROUP ON KP/KV	Y or N	If Y , the order in which items appear on a kitchen requisition is determined by the group to which the item is assigned, i.e. items reported to group 1 will print before items reported to group 2.
PRINT PLU # ON RECEIPT	Y or N	If Y , the PLU number and descriptor will print. If N , only the PLU number will print.
E.J. PORT	0, 1, or 2	Choose a port for a remote printer to print electronic journal reports instead of the register printer.
REPORT PORT	0, 1, or 2	Choose a port for a remote printer to print reports instead of the register printer.
PRINT E.J FROM Y:OLDEST N:NEWEST	Y or N	Y : Prints electronic journal from lowest consecutive number to highest. N : Prints electronic journal from highest consecutive number to lowest.
NOT PRINT WHEN POLLING REPORTS	Y or N	Choose Y if you would like to suppress register printing when reports are polled.
PRINT PLU # ON PLU REPORT	Y or N	Determines whether PLU# is displayed on the report.
GRAND TOTAL IS Y:NET N:GROSS	Y or N	Choose Y if you wish the grand total to accumulate daily net sales totals. Choose N if you wish the grand total to accumulate daily gross sales totals.

Option	Entry	Description
SEND ORDER TO KP AT SUBTOTAL	Y or N	Choose Y to print orders on the KP when the SUBTOTAL key is pressed. Choose N to print orders on the KP when the order is finalized.
PRINT DATE ON SERV ON HARD CHECK	Y or N	If Y , the posting date will print at every posting on the hard check.

Clerk Programming

1. At the **PGM** control lock position menu, press **6** for **CLERK**. The **CLERK NUMBER** screen displays:

```
CLERK NUMBER
CLERK NO ? (1-??) 0←
```

2. Enter the clerk number 1-99, (**the actual number of clerks is set in memory allocation**). Press the **ENTER** key to display the **CLERK #** programming screen:

Descriptor

Type the descriptor using the Program Overlay or by using the descriptor code method (see page 117.). The overlay is automatically activated when the cursor is pointing at the **DESC** field.

```
CLERK #1 PROGRAMMING
NAME                               ←
PASSWORD                           0
DRAWER ASSIGN (0-2) 1
```

← Press **ENTER** to advance the arrow to the next option.

3. Refer to "Clerk Programming - Reference Information" to make choices or changes on the screens provided.
4. After making new entries or changes for a function key, press the **CLEAR** key to finalize and return to the **PROGRAM MODE** screen.

Clerk Programming - Reference Information

Option	Entry	Description
NAME	Alpha numeric 12 character	You can program a descriptor for each clerk. The name you program will print on the receipt in place of the default CLERK #1-99. Type the descriptor using the Program Overlay or by using the descriptor code method (see page 117.) The overlay is automatically activated when the cursor is pointing at the DESC field.
PASSWORD	10 digit number	If you are using a direct or code entry clerk system. The number you set here is the number you must use to sign on or clock in/out.
DRAWER	0-2	Enter 0 to allow check track operations only. (No cash sales.) Enter 1 or 2 (with the multiple drawer option) to select which drawer the clerk will open.

Function Key Programming

1. From the **PGM** control lock position menu, press **5** for **FUNCTION KEY**.
The **FUNCTION KEY PROGRAM** screen displays:

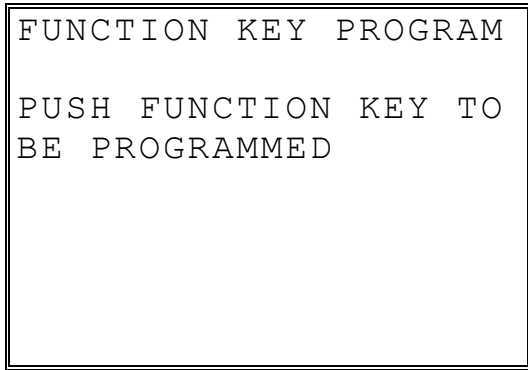
A rectangular box representing a screen display. The text inside is centered and reads: "FUNCTION KEY PROGRAM" on the first line, "PUSH FUNCTION KEY TO" on the second line, and "BE PROGRAMMED" on the third line.

```
FUNCTION KEY PROGRAM
PUSH FUNCTION KEY TO
BE PROGRAMMED
```

2. Press the function key you wish to program.

If the function you wish to program is located on a function look-up key, press the appropriate function look-up key, then press **1** to select **STATUS PROGRAM** (meaning you wish to program the status of the function not the menu assignment of the function look-up key) then press the digit corresponding to the function you wish to program

#/NS

1. Press the **#/NS** key to view the **#/NS** function key options:

```
#/NS KEY PROG.  ↓
DESC1 : NOSALE  ←
DESC2 : NON ADD #
KEY DISABLE      N
UNDER MGR CONTROL N
INHIBIT NO SALE
AFTER NON-ADD #  N
```

2. Press **ENTER** from the last field or press **PAGE DOWN** to view the second page of **#/NS** function key options:

```
#/NS KEY PROG.  ↑
ENFORCE# ENTRY AT
START OF SALE    N←
PRINT ON N/S     Y
NON-ADD# PROHIBIT N
COMP. NON-ADD# MUST
MATCH MAX DIGIT N
MAX DIGIT(0-8)  0
```

3. Press **ENTER** from the last field to return to the **FUNCTION KEY PROGRAM** screen, or press **ESC** at any time to return to the **FUNCTION KEY PROGRAM** screen without saving changes.

#/NO SALE Function Options

Option	Entry	Description
DESC1	Alpha numeric 12 character	You can program a descriptor for the no sale function. The default descriptor is NOSALE.
DESC2	Alpha numeric 12 character	You can program a descriptor for the non add # function. The default descriptor is NON ADD #.
KEY DISABLE	Y or N	Select Y to disable this function.
UNDER MGR CONTROL	Y or N	Select Y to allow operation only in manager operation mode.
INHIBIT NO SALE AFTER NON-ADD #	Y or N	Select Y if you want disable the NO SALE function after a non-add number is entered.
ENFORCE # ENTRY AT START OF SALE	Y or N	Select Y if you wish to enforce the entry of a non-add number at the beginning of each transaction. (For example, to track the number of customers in each sale, or to identify a customer number with each sale.)
PRINT ON N/S	Y or N	Select N to stop printing when a NO SALE is performed.
NON-ADD # PROHIBIT	Y or N	Select Y to disable the non-add # function.
COMP NON-ADD # MUST MATCH MAX DIGIT	Y or N	Select Y if you wish all non-add number entries to have the exact number of digits selected in the MAX DIGIT flag below.
MAX DIGIT (0-8)	0-8	Enter the maximum number of digits for non-add number entry. Zero (0) means no limit.

%1 -%5

1. Press the one of the % keys to view the appropriate % function key options:

%1 PROGRAMMING	↓
DESC : %1	←
AMOUNT:Y %:N	N
RATE	0.000
KEY DISABLE	N
UNDER MGR CONTROL	N
OPEN:Y PRESET:N	N
SALE:Y ITEM:N	N

2. Press **ENTER** from the last field or press **PAGE DOWN** to view the second page of % function key options:

%1 PROGRAMMING	↕
OVERRRIDEABLE	N←
POS.:Y NEG.:N	N
TAXable BY TAX1	N
TAXable BY TAX2	N
TAXable BY TAX3	N
TAXable BY TAX4	N
F/S ELIGIBLE	N

3. Press **ENTER** from the last field or press **PAGE DOWN** to view the next page of % function key options:

%1 PROGRAMMING	↕
ALLOW ONLY ONE TIME	
SUBTOTAL ENTRY	N←
ALLOW MULTIPLE AMT	
DISCOUNT (COUPON)	
WITHOUT SUBTOTAL	N
PRESET OVERRIDE IN	
MGR ONLY	N

4. Press **ENTER** from the last field or press **PAGE DOWN** to view the last page of % function key options:

```
  %1 PROGRAMMING  ↑  
COMPULSORY VALID N←
```

5. Press **ENTER** from the last field to return to the **FUNCTION KEY PROGRAM** screen, or press **ESC** at any time to return to the **FUNCTION KEY PROGRAM** screen without saving changes.

%1 -%5 Function Options

Option	Entry	Description
DESC	Alpha numeric 12 character	You can program a descriptor. The default descriptors are % 1-4.
AMOUNT:Y %:N	Y or N	Select Y if you wish this key to apply an amount (as in a coupon). Select N if you wish this key to apply a percentage (as in a discount or surcharge).
RATE	5 digit	If the function is an amount, enter an amount from 0 to 999.99. If not zero, the amount will be the preset coupon amount. If the function is a percentage, enter a percentage from 0 to 99.999%. If not zero, the percentage will be the preset percentage
KEY DISABLE	Y or N	Select Y to disable this function.
UNDER MGR CONTROL	Y or N	Select Y if you do not want the operator use this function in REGISTER mode. When selected, the function is allowed only in the X control lock position.
OPEN:Y PRESET:N	Y or N	Select Y if you wish the amount or percentage to be entered by the operator; select N if you wish the amount or percentage to be preset.
SALE:Y ITEM:N	Y or N	Select Y if you wish the amount or percentage to apply to the sale total. Select N if you wish the amount or percentage to apply to an item.
OVERRIDEABLE	Y or N	Select Y if you wish to enter a percentage or amount to override the preset percentage or amount set in the RATE field.
POS.:Y NEG.:N	Y or N	Select Y if you wish the amount or percentage to add to the sale total. Select N if you wish the amount or percentage to subtract from the sale.
TAXable BY TAX1 TAXable BY TAX2 TAXable BY TAX3 TAXable BY TAX4	Y or N	Select N to tax any taxable items before the discount or surcharge is applied (tax the gross amount). Select Y to tax any taxable items after the discount or surcharge is applied (tax the net amount).
F/S ELIGIBLE	Y or N	Select Y to reduce (increase) the food stamp subtotal by the amount of % entry.
ALLOW ONLY ONE TIME SUBTOTAL ENTRY	Y or N	If Y , you can enter only a single coupon and you must press the SBTL key before the coupon entry.
ALLOW MULTIPLE AMOUNT DISCOUNT (COUPON) WITHOUT SUBTOTAL ENTRY	Y or N	If you set a % key to be used for vendor coupons (i.e. amount, negative and sale status) then choose Y to allow the function to be operated multiple times, without requiring the SBTL key to be pressed prior to the coupon entry.
PRESET OVERRIDE IN MGR ONLY	Y or N	Select Y to allow preset override only in manager operation mode.
COMPULSORY VALIDATION	Y or N	Choose Y to enforce validation if an optional printer with validation capability is connected to an RS-232C port.

ADD CHECK

1. Press the **ADD CHECK** key to view the add check function key options:

ADD CHECK PROG.	↓
DESC : ADDCHK	←
KEY DISABLE	N
COMPULSORY BEFORE	
TENDERING	N
CONSECUTIVE NUMBER	
ADVANCED	Y
RCPT CONDENCING	N

2. Press **ENTER** from the last field or press **PAGE DOWN** to view the second page of add check function key options:

ADD CHECK PROG.	↑
EXEMPT TAX 1	N←
EXEMPT TAX 2	N
EXEMPT TAX 3	N
EXEMPT TAX 4	N
COMPULSORY VALID	N

3. Press **ENTER** from the last field to return to the **FUNCTION KEY PROGRAM** screen, or press **ESC** at any time to return to the **FUNCTION KEY PROGRAM** screen without saving changes.

ADD CHECK Key Program Notes

Option	Entry	Description
DESC	Alpha numeric 12 character	You can program a descriptor. The default descriptor is ADD CHECK.
KEY DISABLE	Y or N	Select Y to disable this function.
COMPULSORY BEFORE TENDERING	Y or N	Select Y if you want to force the operator to use the ADD CHECK function before tendering.
CONSECUTIVE NUMBER ADVANCED	Y or N	Select Y if you want to advance the consecutive number each time the ADD CHECK key is used.
RCPT CONDENCING	Y or N	Select Y if you want to delete the preamble and postamble each time the ADD CHECK key is used.
EXEMPT TAX 1 EXEMPT TAX 2 EXEMPT TAX 3 EXEMPT TAX 4	Y or N	Select Y to exempt the appropriate tax automatically when finalized with this key.
COMPULSORY VALIDATION	Y or N	Choose Y to enforce validation if an optional printer with validation capability is connected to an RS-232C port.

CANCEL

1. Press the **CANCEL** key to view the cancel function key options:

CANCEL KEY PROG.		
DESC :	CANCEL	←
KEY HALO	0.00	
(0 : NO LIMIT)		
KEY DISABLE		N
UNDER MGR CONTROL		N

2. Press **ENTER** from the last field to return to the **FUNCTION KEY PROGRAM** screen, or press **ESC** at any time to return to the **FUNCTION KEY PROGRAM** screen without saving changes.

CANCEL Key Program Notes

Option	Entry	Description
DESC	Alpha numeric 12 character	You can program a descriptor. The default descriptor is CANCEL.
HALO	7 digit amount	You can limit errors by setting the maximum amount that can be used with this function. "0" means that there is no entry limit.
KEY DISABLE	Y or N	Select Y to disable this function.
UNDER MGR CONTROL	Y or N	Select Y if you do not want the operator use this function in REGISTER mode. When selected, the function is allowed only in the X control lock position.

CASH

1. Press the **CASH** key to view the cash function key options:

```
CASH KEY PROG.  ↓
DESC : CASH      ←
HALO              0.00
(0 : NO LIMIT)
AMT TEND COMP.   N
OVER/UNDER TENDER
IN MGR CONTROL   N
DISABLE UNDER TND.N
```

2. Press **ENTER** from the last field or press **PAGE DOWN** to view the second page of cash function key options:

```
CASH KEY PROG.  ↑
DOES DRAWER OPEN Y←
EXEMPT TAX 1    N
EXEMPT TAX 2    N
EXEMPT TAX 3    N
EXEMPT TAX 4    N
COMPULSORY VALID N
```

3. Press **ENTER** from the last field to return to the **FUNCTION KEY PROGRAM** screen, or press **ESC** at any time to return to the **FUNCTION KEY PROGRAM** screen without saving changes.

CASH Key Program Notes

Option	Entry	Description
DESC	Alpha numeric 12 character	You can program a descriptor. The default descriptor is CASH.
HALO	7 digit amount	You can limit errors by setting the maximum amount that can be tendered. "0" means that there is no entry limit.
AMOUNT TEND COMP.	Y or N	Select Y if you want to force the operator to enter the tendered amount and let the register calculate the change.
OVER/UNDER TENDER IN MGR CONTROL	Y or N	Select Y if you do not want the operator to tender more than the amount of the sale and issue change. When selected, over and under tendering is allowed only in the X control lock position.
DISABLE UNDER TEND.	Y or N	Select Y if you do not want the operator to tender less than the amount of the sale.
DOES DRAWER OPEN	Y or N	Select N if you do not want the drawer to opened with this key.
EXEMPT TAX 1 EXEMPT TAX 2 EXEMPT TAX 3 EXEMPT TAX 4	Y or N	Select Y to exempt the appropriate tax automatically when finalized with this key.
COMPULSORY VALIDATION	Y or N	Choose Y to enforce validation if an optional printer with validation capability is connected to an RS-232C port.

CHARGE 1-8

1. Press one of the CHARGE key to view the appropriate charge function key options:

```
CHARGE 1 PROG.  ↓
DESC : CHARGE1   ←
KEY HALO          0.00
(0 : NO LIMIT)
AMOUNT TEND COMP. N
OVER/UNDER TENDER
IN MGR CONTROL   N
DISABLE UNDER TND.N
```

2. Press **ENTER** from the last field or press **PAGE DOWN** to view the second page of charge function key options:

```
CHARGE 1 PROG.  ↑↓
DOES DRAWER OPEN N←
ALLOW OVER TEND  N
NON-ADD # COMP.  N
EXEMPT TAX 1     N
EXEMPT TAX 2     N
EXEMPT TAX 3     N
EXEMPT TAX 4     N
```

3. Press **ENTER** from the last field or press **PAGE DOWN** to view the last page of charge function key options:

```
CHARGE 1 PROG.  ↑
COMPULSORY VALID N←
LAN TRAN         N
LAN TRAN ACTION
CODE (0-8)       0
```

4. Press **ENTER** from the last field to return to the **FUNCTION KEY PROGRAM** screen, or press **ESC** at any time to return to the **FUNCTION KEY PROGRAM** screen without saving changes.

CHARGE 1-8 Key Program Notes

Option	Entry	Description
DESC	Alpha numeric 12 character	You can program a descriptor. The default descriptors are CHARGE 1-8.
HALO	7 digit amount	You can limit errors by setting the maximum amount that can be tendered. "0" means that there is no entry limit.
AMOUNT TEND COMP.	Y or N	Select Y if you want to force the operator to enter the tendered amount and let the register calculate the change.
OVER/UNDER TENDER IN MGR CONTROL	Y or N	Select Y if you do not want the operator to tender more than the amount of the sale and issue change. When selected, over tendering is allowed only in the X control lock position.
DISABLE UNDER TEND.	Y or N	Select Y if you do not want the operator to tender less than the amount of the sale.
DOES DRAWER OPEN	Y or N	Select N if you do not want the drawer to opened with this key.
ALLOW OVER TEND.	Y or N	Select Y if you wish to allow tender greater than the amount of the sale.
NON-ADD # COMP.	Y or N	Select Y if you wish to enforce the entry of a non-add number prior to tendering.
EXEMPT TAX 1 EXEMPT TAX 2 EXEMPT TAX 3 EXEMPT TAX 4	Y or N	Select Y to exempt the appropriate tax automatically when finalized with this key.
COMPULSORY VALIDATION	Y or N	Choose Y to enforce validation if an optional printer with validation capability is connected to an RS-232C port.
LAN TRAN	Y or N	Set to Y if connected to a Lan Tran credit authorization terminal.
LAT TRAN ACTION CODE	0-8	

CHECK CASHING

1. Press the **CHECK CASHING** key to view the check cashing function key options:

<pre> CHECK CASH PROG. DESC : CHKCASH ← KEY HALO 0.00 (0 : NO LIMIT) KEY DISABLE N UNDER MGR CONTROL N COMPULSORY VALID N </pre>
--

2. Press **ENTER** from the last field to return to the **FUNCTION KEY PROGRAM** screen, or press **ESC** at any time to return to the **FUNCTION KEY PROGRAM** screen without saving changes.

CHECK CASHING Key Program Notes

Option	Entry	Description
DESC	Alpha numeric 12 character	You can program a descriptor. The default descriptor is CHKCASH.
HALO	7 digit amount	You can limit errors by setting the maximum amount that can be used with this function. "0" means that there is no entry limit.
KEY DISABLE	Y or N	Select Y to disable this function.
UNDER MGR CONTROL	Y or N	Select Y if you do not want the operator use this function in REGISTER mode. When selected, the function is allowed only in the X control lock position.
COMPULSORY VALIDATION	Y or N	Choose Y to enforce validation if an optional printer with validation capability is connected to an RS-232C port.

CHECK ENDORSEMENT

1. Press the **CHECK ENDORSEMENT** key to view the check endorsement function key options:

CHECK ENDORSEMENT	↓
DESC : CHKENDOR	←
KEY DISABLE	N
PRINT CHECK AMT IN THE ENDORSEMENT	N
PRINT OPTION	
PRINT DATE	N
PRINT TIME	N

2. Press **ENTER** from the last field or press **PAGE DOWN** to view the second page of check endorsement function key options:

CHECK ENDORSEMENT	↑
PRINT CLERK	N←
CONSECUTIVE No.	N

3. Press **ENTER** from the last field to return to the **FUNCTION KEY PROGRAM** screen, or press **ESC** at any time to return to the **FUNCTION KEY PROGRAM** screen without saving changes.

CHECK ENDORSEMENT Key Program Notes

Option	Entry	Description
DESC	Alpha numeric 12 character	You can program a descriptor. The default descriptor is CHKENDOR.
KEY DISABLE	Y or N	Select Y to disable this function.
PRINT CHECK AMT IN THE ENDORSEMENT	Y or N	Choose Y to print the amount of the check as well as the endorsement message. Choose N to print only the endorsement message. Note: A 10 line check endorsement message may be programmed. See "Endorsement Message" on page 213 for more information.
PRINT OPTION PRINT DATE PRINT TIME PRINT CLERK CONSECUTIVE No.	Y or N	Choose Y or N to determine whether each option prints on the check endorsement.

CHECK

1. Press the **CHECK** key to view the check function key options:

```
CHECK KEY PROG.  ↓
DESC : CHECK    ←
HALO              0.00
(0 : NO LIMIT)
AMOUNT TEND COMP. N
OVER/UNDER TENDER
IN MGR CONTROL   N
DISABLE UNDER TND.N
```

2. Press **ENTER** from the last field or press **PAGE DOWN** to view the second page of check function key options:

```
CHECK KEY PROG.  ↕
DOES DRAWER OPEN  N
EXEMPT TAX 1      N
EXEMPT TAX 2      N
EXEMPT TAX 3      N
EXEMPT TAX 4      N
COMPULSORY CHECK
ENDORSEMENT       N
```

3. Press **ENTER** from the last field or press **PAGE DOWN** to view the third page of check function key options:

```
CHECK KEY PROG.  ↑
COMPULSORY VALID  N
```

4. Press **ENTER** from the last field to return to the **FUNCTION KEY PROGRAM** screen, or press **ESC** at any time to return to the **FUNCTION KEY PROGRAM** screen without saving changes.

CHECK Key Program Notes

Option	Entry	Description
DESC	Alpha numeric 12 character	You can program a descriptor. The default descriptor is CHECK.
HALO	7 digit amount	You can limit errors by setting the maximum amount that can be tendered. "0" means that there is no entry limit.
AMOUNT TEND COMP.	Y or N	Select Y if you want to force the operator to enter the tendered amount and let the register calculate the change.
OVER/UNDER TENDER IN MGR CONTROL	Y or N	Select Y if you do not want the operator to tender more than the amount of the sale and issue change. When selected, over tendering is allowed only in the X control lock position.
DISABLE UNDER TEND.	Y or N	Select Y if you do not want the operator to tender less than the amount of the sale.
DOES DRAWER OPEN	Y or N	Select N if you do not want the drawer to open with this key.
EXEMPT TAX 1 EXEMPT TAX 2 EXEMPT TAX 3 EXEMPT TAX 4	Y or N	Select Y to exempt the appropriate tax automatically when finalized with this key.
COMPULSORY CHECK ENDORSEMENT	Y or N	Choose Y to enforce check endorsement if an optional printer with endorsement capability is connected to an RS-232C port.
COMPULSORY VALIDATION	Y or N	Choose Y to enforce validation if an optional printer with validation capability is connected to an RS-232C port.

CHECK

1. Press the **CHECK TRACK #** key to view the check track function key options:

```
CHECK TRACK PROG. ↓
DESC : CHECK #      ←
KEY DISABLE          N
COMPULSORY FOR ALL
SALES                N
OPENING CLERK HAS
EXCLUSIVE ACCESS    N
PRINT ON RECEIPT    Y
```

2. Press **ENTER** from the last field or press **PAGE DOWN** to view the second page of check track function key options:

```
CHECK TRACK PROG. ↕
PRINT CHKS ON RP    Y ←
ALLOW ONLY ONE CHK
PER TABLE          N
CHECK # ASSIGNED
BY REGISTER         N
DRIVE THRU FEATURE
ENABLED             N
```

3. Press **ENTER** from the last field or press **PAGE DOWN** to view the second page of check track function key options:

```
CHECK TRACK PROG. ↑
LENGTH OF CHECK
(0-9)                0
SCAN CHECK #        N
```

4. Press **ENTER** from the last field to return to the **FUNCTION KEY PROGRAM** screen, or press **ESC** at any time to return to the **FUNCTION KEY PROGRAM** screen without saving changes.

CHECK # Key Program Notes

Option	Entry	Description
DESC	Alpha numeric 12 character	You can program a descriptor. The default descriptor is CHKTRACK.
KEY DISABLE	Y or N	Select Y to disable this function.
COMPULSORY FOR ALL SALES	Y or N	Select Y you must begin a new, or recall an existing tracking number before registering items.
OPENING CLERK HAS EXCLUSIVE ACCESS	Y or N	If Y , the clerk that begins a tracking number is the only clerk who can recall a check. If N , any clerk can recall any check.
PRINT ON RECEIPT	Y or N	If N , the check track number and balance will not print on the receipt.
PRINT ON REMOTE	Y or N	If N , the check track number and balance will not print on the remote.
ALLOW ONLY ONE CHK PER TABLE	Y or N	If Y , you can begin only one check with the same table #.
CHECK # ASSIGNED BY REGISTER	Y or N	If Y , press the CHECK.# key to automatically assign the next sequential check. Check numbers will begin with #1 and continue until the open check report is reset, at which point the check number will be reset and start at #1 again.
DRIVE THRU FEATURE ENABLED	Y or N	If you wish to implement a drive thru recall key, this setting changes the function of the PBAL key to that of a recall key. Press the PBAL key directly to automatically recall the open check with the lowest tracking number
LENGTH OF CHECK (0-9)	Y or N	Set the length of check in number of digits. For example, if 4, then checks must be used in the range from 1000, to 9999. This setting applies only to check numbers input by the operator, not to check numbers assigned by the register.
SCAN CHECK #	Y or N	Choose Y to allow the check number to be input by a scanner (must be nine digits or less).

CURRENCY CONVERSION 1-4

1. Press one of the **CURRENCY CONVERSION** keys to view the appropriate currency conversion function key options:

CONVERSION #1 PROG.	
DESC : CONV1	←
RATE	0
NUMBER OF DEC.	0

2. Press **ENTER** from the last field to return to the **FUNCTION KEY PROGRAM** screen, or press **ESC** at any time to return to the **FUNCTION KEY PROGRAM** screen without saving changes.

CURRENCY CONVERSION 1-4 Program Notes

DESC	Alpha numeric 12 character	You can program a descriptor for each foreign currency. The default descriptors are CONV 1-4.
RATE	5 digits	Enter the exchange rate of up to 5 digits (do not enter the decimal point). See the examples on the next page.
NUMBER OF DEC.	1 - 6	Enter a number from 0 to 6 to indicate the decimal position of the exchange rate. Count the decimal position from the right. See the examples below.

Currency Exchange Rate Programming Examples

Note: Foreign currency exchange rates can be stated as “foreign currency in dollars”, or “dollars in foreign currency”. Use the rate stated in “dollars in foreign currency” when you are programming this section.

The US dollar (home currency) is worth 1.3720 Canadian dollars (foreign currency).

RATE: 13720

NUMBER OF DEC.: 5

The US dollar (home currency) is worth 110.24 Japanese Yen (foreign currency).

RATE: 11024

NUMBER OF DEC.: 2

EAT-IN TAKE OUT DRIVE THRU

1. Press the **EAT-IN**, **TAKE OUT**, or **DRIVE THRU** key to view the appropriate function key options:

EAT-IN PROG .		
DESC :	EATIN	←
EXEMPT TAX 1		N
EXEMPT TAX 2		N
EXEMPT TAX 3		N
EXEMPT TAX 4		N
COMPULSORY VALID		N

2. Press **ENTER** from the last field to return to the **FUNCTION KEY PROGRAM** screen, or press **ESC** at any time to return to the **FUNCTION KEY PROGRAM** screen without saving changes.

EAT-IN/TAKE OUT/DRIVE THRU Key Program Notes

Option	Entry	Description
DESC	Alpha numeric 12 character	You can program a descriptor. The default descriptors are EATIN, TAKE OUT and DRIVE THRU.
EXEMPT TAX 1 EXEMPT TAX 2 EXEMPT TAX 3 EXEMPT TAX 4	Y or N	If you wish to automatically exempt a tax for a particular type of sale, select Y for the appropriate tax. For example, if items are non-taxable for take out, but taxable for eat-in, set this program to exempt tax on take out sales.
COMPULSORY VALIDATION		Choose Y to enforce validation if an optional printer with validation capability is connected to an RS-232C port.

ERROR CORRECT

1. Press the **ERROR CORRECT** key to view the error correct function key options:

```

ERR CORRECT PROG.
DESC : ERRCORR      ←
KEY HALO           0.00
(0 : NO LIMIT)
KEY DISABLE                N
UNDER MGR CONTROL  N
  
```

2. Press **ENTER** from the last field to return to the **FUNCTION KEY PROGRAM** screen, or press **ESC** at any time to return to the **FUNCTION KEY PROGRAM** screen without saving changes.

ERROR CORRECT Key Program Notes

Option	Entry	Description
DESC	Alpha numeric 12 character	You can program a descriptor. The default descriptor is ERRCORR.
HALO	7 digit amount	You can limit errors by setting the maximum amount that can be used with this function. "0" means that there is no entry limit.
KEY DISABLE	Y or N	Select Y to disable this function.
UNDER MGR CONTROL	Y or N	Select Y if you do not want the operator use this function in REGISTER mode. When selected, the function is allowed only in the X control lock position.

F/S TEND

1. Press the **F/S TEND** key to view the food stamp tender function key options:

FOOD STAMP PROG.	↓
DESC : F/S TEND	←
HALO	0.00
EXEMPT TAX 1	N
EXEMPT TAX 2	N
EXEMPT TAX 3	N
EXEMPT TAX 4	N
ALLOW DECIMAL	N

2. Press **ENTER** from the last field or press **PAGE DOWN** to view the second page of food stamp tender function key options:

FOOD STAMP PROG.	↑
CHANGE IS ISSUED	
IN CASH	N←
DOES DRAWER OPEN	N
COMPULSORY VALID	N

3. Press **ENTER** from the last field to return to the **FUNCTION KEY PROGRAM** screen, or press **ESC** at any time to return to the **FUNCTION KEY PROGRAM** screen without saving changes.

F/S TEND Key Program Notes

Option	Entry	Description
DESC	Alpha numeric 12 character	You can program a descriptor. The default descriptor is F/S TEND.
HALO	7 digit amount	You can limit errors by setting the maximum amount that can be used with this function. "0" means that there is no entry limit.
EXEMPT TAX 1 EXEMPT TAX 2 EXEMPT TAX 3 EXEMPT TAX 4	Y or N	If taxes are exempted automatically on food stamp sales (as is most often the case) select Y for each tax that is actively used and needs to be exempted.
ALLOW DECIMAL	Y or N	If N , food stamp tender must be in whole dollar amounts, i.e. \$1, \$5, or \$10. If Y , the tender is allowed in any amount.
CHANGE IS ISSUED IN CASH	Y or N	If Y , food stamp change less than \$1 will be issued in cash.
DOES DRAWER OPEN	Y or N	Select N if you do not want the drawer to opened with this key.
COMPULSORY VALIDATION	Y or N	Choose Y to enforce validation if an optional printer with validation capability is connected to an RS-232C port.

FUNCTION LOOK UP (1-2)

Two function keys (**FUNCTION LOOK 1** and **FUNCTION LOOK 2**) are available to access up to eight functions each. You can use function look up keys to locate functions that are necessary for your application, but may not fit on the keyboard layout, or to locate functions that are used only occasionally.

With this program, you can determine which functions are located on each function look up key, and you can also access these functions for option programming.

1. Press the **FUNCTION LOOK UP 1** or **FUNCTION LOOK UP 2** key to view the appropriate function program menu screen:

```
FUNC #1 PROGRAM
0. MENU ASSIGNMENT
1. STATUS PROGRAM
```

2. Press **0** to select the menu assignment on the function look-up key or press **1** to program the options for a function on the function look-up key. If you are programming function key options, refer to each function separately in this chapter to set function options. If you chose **0** to program menu assignment, the **FUNC. # MENU ASSIGN** screen displays:

```
FUNC #1 MENU ASSIGN.
PUSH MENU NUMBER TO
BE PROGRAMMED (1-8)
0 ←
```

3. Enter the number of the menu position (there are eight functions listed on each function look up menu) that you wish to edit, press **ENTER**.

```
FUNC #1 MENU ASSIGN.  
  
MENU NUMBER :      1  
CURRENT ASSIGNMENT  
    CHARGE1  
ENTER NEW FUNC CODE,  
PRESS ENTER  
  
0 ←
```

4. Type the code for the function you wish to place on the function look up key menu, press **ENTER**. See "Function Key Codes" in the "Service Mode Programming" chapter, or press **PAGE DOWN** to view a list of functions and codes.
5. Go to step 2 above and continue to program menu numbers for the function look up key, or press **ESC** to return to the **PROGRAM MODE** menu.

GUEST

1. Press the **GUEST** key to view the guest function key options:

GUEST # PROG .	
DESC : GUEST	←
COMPULSORY FOR	
GUEST CHECK	N
COMPULSORY FOR ALL	
SALES	N
PRINT AT REMOTE	
PRINTER	N

2. Press **ENTER** from the last field to return to the **FUNCTION KEY PROGRAM** screen, or press **ESC** at any time to return to the **FUNCTION KEY PROGRAM** screen without saving changes.

GUEST Key Program Notes

Option	Entry	Description
DESC	Alpha numeric 12 character	You can program a descriptor. The default descriptor is GUEST.
COMPULSORY FOR GUEST CHECK	Y or N	Select Y to enforce an entry into the GUEST # key before a tracking number can be accessed for the first time.
COMPULSORY FOR ALL SALES	Y or N	Select Y to enforce an entry into the GUEST # key before an item can be registered on any sale.
PRINT AT REMOTE PRINTER	Y or N	Select N if you do not want GUEST # entry to print at the kitchen printer if items from the same transaction are sent to the KP.

LEVEL 1-5

1. Press one of the **LEVEL** keys to view the level function key options:

```
LEVEL 1 PROG .
DESC : LEVEL1      ←
SEND DESCRIPTION  N
TO KP
```

2. Press **ENTER** from the last field to return to the **FUNCTION KEY PROGRAM** screen, or press **ESC** at any time to return to the **FUNCTION KEY PROGRAM** screen without saving changes.

LEVEL 1-5 Key Program Notes

Option	Entry	Description
DESC	Alpha numeric 12 character	You can program a descriptor. The default descriptors are LEVEL1, LEVEL2, etc. .
SEND DESCRIPTION TO KP	Y or N	Determines whether the level descriptor prints with the item at the KP.

MDSE RETURN

1. Press the **MDSE RETURN** key to view the merchandise return function key options:

```

RETURN KEY PROG.
DESC : MDSE RETURN ←
KEY HALO          0.00
(0 : NO LIMIT)
KEY DISABLE              N
UNDER MGR CONTROL      N
    
```

2. Press **ENTER** from the last field to return to the **FUNCTION KEY PROGRAM** screen, or press **ESC** at any time to return to the **FUNCTION KEY PROGRAM** screen without saving changes.

MDSE RETURN Key Program Notes

Option	Entry	Description
DESC	Alpha numeric 12 character	You can program a descriptor. The default descriptor is MDSE RETURN.
HALO	7 digit amount	You can limit errors by setting the maximum amount that can be used with this function. "0" means that there is no entry limit.
KEY DISABLE	Y or N	Select Y to disable this function.
UNDER MGR CONTROL	Y or N	Select Y if you do not want the operator use this function in REGISTER mode. When selected, the function is allowed only in the X control lock position.

MODIFIER 1-5

1. Press one of the **MODIFIER** keys to view the appropriate modifier function key options:

```
MOD 1 PROG.      ↓
DESC : MOD1      ←
UNDER MGR CONTROL N
AFFECT PLU #      N
PRINT ON CHECK    N
PRINT ON RECEIPT  N
AFFECT DIGIT 1-14
OF PLU#           0
```

2. Press **ENTER** from the last field or press **PAGE DOWN** to view the second page of modifier function key options:

```
MOD 1 PROG.      ↑
VALUE OF AFFECTED
DIGIT(0-9)       0 ←
SEND DESCRIPTION
TO KP            N
```

3. Press **ENTER** from the last field to return to the **FUNCTION KEY PROGRAM** screen, or press **ESC** at any time to return to the **FUNCTION KEY PROGRAM** screen without saving changes.

MODIFIER 1-5 Key Program Notes

Option	Entry	Description
DESC	Alpha numeric 12 character	You can program a descriptor. The default descriptors are MOD1 - MOD5.
UNDER MGR CONTROL	Y or N	Select Y if you do not want the operator use this function in REGISTER mode. When selected, the function is allowed only in the X control lock position.
AFFECT PLU #	Y or N	Select Y , if you wish the modifier entry to modify the PLU and cause a different item/price to be registered. Select N to only add the modifier descriptor.
PRINT ON CHECK	Y or N	Select N to suppress printing of the modifier descriptor on the guest check.
PRINT ON RECEIPT	Y or N	Select N to suppress printing of the modifier descriptor on the receipt.
AFFECT DIGIT 1-14	1-14	Preceding a PLU with a Size and/or Modifier key manipulates the PLU code assigned to the PLU key, causing a different PLU to be registered when the PLU key is pressed. Enter the digit of the PLU number you wish to be changed when using this key. (Digit #1 is the rightmost digit; digit #14 is the leftmost digit.)
VALUE OF AFFECTED DIGIT (0-9)	0-9	Enter the value you wish to be added in the digit position selected. For example, if you wish to affect PLU digit #4 with a value of 1, then pressing this modifier key prior to the registration of PLU #17 will result in the registration of PLU #1017.
SEND DESCRIPTION TO KP	Y or N	Determines whether the modifier descriptor prints with the item at the KP. (The modifier descriptor will print immediately above the item.)

PBAL

1. Press the **PBAL** key to view the previous balance function key options:

```
PREVIOUS BAL. PROG.  
DESC : PBAL          ←  
ENTER ANY TIME      N  
REQUIRE AT START OF  
SALE                N
```

2. Press **ENTER** from the last field to return to the **FUNCTION KEY PROGRAM** screen, or press **ESC** at any time to return to the **FUNCTION KEY PROGRAM** screen without saving changes.

PBAL Key Program Notes

Option	Entry	Description
DESC	Alpha numeric 12 character	You can program a descriptor. The default descriptor is PBAL.
ENTER ANY TIME	Y or N	Select Y to allow the PBAL entry at any time. Select N to allow a PBAL entry only at the start of a sale.
REQUIRE AT START OF SALE	Y or N	Select Y to require an entry into the PBAL key at the start of every transaction.

PAID OUT 1-3

1. Press one of the **PAID OUT** keys to view the paid out function key options:

<pre> PO #1 KEY PROG . DESC : PO1 ← KEY HALO 0.00 (0 : NO LIMIT) KEY DISABLE N UNDER MGR CONTROL N COMPULSORY VALID N </pre>
--

2. Press **ENTER** from the last field to return to the **FUNCTION KEY PROGRAM** screen, or press **ESC** at any time to return to the **FUNCTION KEY PROGRAM** screen without saving changes.

PAID OUT 1-3 Key Program Notes

Option	Entry	Description
DESC	Alpha numeric 12 character	You can program a descriptor. The default descriptors are PO 1-3.
HALO	7 digit amount	You can limit errors by setting the maximum amount that can be used with this function. "0" means that there is no entry limit.
KEY DISABLE	Y or N	Select Y to disable this function.
UNDER MGR CONTROL	Y or N	Select Y if you do not want the operator use this function in REGISTER mode. When selected, the function is allowed only in the X control lock position.
COMPULSORY VALIDATION	Y or N	Choose Y to enforce validation if an optional printer with validation capability is connected to an RS-232C port.

PRINT CHECK

1. Press the **PRINT CHECK** key to view the print check function key options:

```

PRINT CHECK PROG.
DESC : PRINT CHECK ←
CHECK PRINT
  COM PORT # (0-2)  0
AUTO SERVICE CHK  N
PRT CHECK ON RECP N
SKIP PRT OF CONSEC#
ON CHECK           N
    
```

2. Press **ENTER** from the last field to return to the **FUNCTION KEY PROGRAM** screen, or press **ESC** at any time to return to the **FUNCTION KEY PROGRAM** screen without saving changes.

PRINT CHECK Key Program Notes

Option	Entry	Description
DESC	Alpha numeric 12 character	You can program a descriptor. The default descriptor is PRINT CHECK.
CHECK PRINT COMM PORT # (0-2)	0-2	Select the port (1 or 2) where the check print printer is attached. If 0 is selected, the check will print on the receipt printer.
AUTO SERVICE CHK	Y or N	Select Y if you want the Check Print function to automatically service the check.
PRT CHECK ON RECP	Y or N	Select Y if you want the Check Print function to print on the receipt printer.
SKIP PRT OF CONSEC# ON CHECK	Y or N	Select Y if you wish to delete the printing of the consecutive # on the guest check.

PROMO

1. Press the **PROMO** key to view the promotion function key options:

PROMO PROG .		
DESC :	PROMO	←
KEY DISABLE		N
UNDER MGR CONTROL		N
TAXABLE BY TAX1		N
TAXABLE BY TAX2		N
TAXABLE BY TAX3		N
TAXABLE BY TAX4		N

2. Press **ENTER** from the last field to return to the **FUNCTION KEY PROGRAM** screen, or press **ESC** at any time to return to the **FUNCTION KEY PROGRAM** screen without saving changes.

PROMO Key Program Notes

Option	Entry	Description
DESC	Alpha numeric 12 character	You can program a descriptor. The default descriptor is PROMO.
KEY DISABLE	Y or N	Select Y to disable this function.
UNDER MGR CONTROL	Y or N	Select Y if you do not want the operator use this function in REGISTER mode. When selected, the function is allowed only in the X control lock position.
TAXABLE BY TAX1 TAXABLE BY TAX2 TAXABLE BY TAX3 TAXABLE BY TAX4	Y or N	If an item is taxable, and you wish to remove taxes and an item's cost when using the PROMO key, set the taxable status for the appropriate tax to Y .

RECD ON ACCT 1-3

1. Press one of the **RECD ON ACCT** keys to view the received on account function key options:

<pre> RA #1 KEY PROG. DESC : RA1 ← KEY HALO 0.00 (0 : NO LIMIT) KEY DISABLE N UNDER MGR CONTROL N COMPULSORY VALID N </pre>
--

2. Press **ENTER** from the last field to return to the **FUNCTION KEY PROGRAM** screen, or press **ESC** at any time to return to the **FUNCTION KEY PROGRAM** screen without saving changes.

RECD ON ACCT 1-3 Key Program Notes

Option	Entry	Description
DESC	Alpha numeric 12 character	You can program a descriptor. The default descriptors are RA 1-3.
HALO	7 digit amount	You can limit errors by setting the maximum amount that can be used with this function. "0" means that there is no entry limit.
KEY DISABLE	Y or N	Select Y to disable this function.
UNDER MGR CONTROL	Y or N	Select Y if you do not want the operator use this function in REGISTER mode. When selected, the function is allowed only in the X control lock position.
COMPULSORY VALIDATION	Y or N	Choose Y to enforce validation if an optional printer with validation capability is connected to an RS-232C port.

SCALE

1. Press the **SCALE** key to view the scale function key options:

```
SCALE KEY PROG. ↓
DESC : SCALE ←
KEY DISABLE N
UNDER MGR CONTROL N
KEY IS MAN. ENTRY N
TARE-WEIGHT COMP. N
WEIGHT SYMBOL FOR
MAN (N:lb Y:kg) N
```

2. Press **ENTER** from the last field or press **PAGE DOWN** to view the second page of scale function key options:

```
SCALE KEY PROG. ↑
ALLOW DOLLAR ENTRY N ←
W/O SCALE ON
SCALEABLE ITEM
```

3. Press **ENTER** from the last field to return to the **FUNCTION KEY PROGRAM** screen, or press **ESC** at any time to return to the **FUNCTION KEY PROGRAM** screen without saving changes.

SCALE Key Program Notes

Option	Entry	Description
DESC	Alpha numeric 12 character	You can program a descriptor. The default descriptor is SCALE.
KEY DISABLE	Y or N	Select Y to disable this function.
UNDER MGR CONTROL	Y or N	Select Y if you do not want the operator use this function in REGISTER mode. When selected, the function is allowed only in the X control lock position.
KEY IS MAN. ENTRY	Y or N	Select Y if you wish to scale key to enter a manual weight. Select N if you wish to automatically recall the weight from the attached scale.
TARE-WEIGHT COMP.	Y or N	Select Y if you wish to enforce the subtraction of a tare weight on the scale entry.
WEIGHT SYMBOL FOR MAN (N:LB Y:KG)	Y or N	Select Y if you wish to use the weight symbol Kg (kilogram) for weights entered manually.
ALLOW DOLLAR ENTRY W/O SCALE ON SCALEABLE ITEM	Y or N	If N , you must use the scale to register scaleable PLU items. If Y , you can either register scaleable items by weight extension, or by price entry.

SERVICE

1. Press the **SERVICE** key to view the service function key options:

```
SERVICE KEY PROG.↓
DESC : SERVICE    ←
NON-ADD # COMP    N
PRINT ON RECEIPT  Y
NEGATIVE BALANCE
  IN MGR CONTROL  N
CALCULATE TAX1    Y
CALCULATE TAX2    Y
```

2. Press **ENTER** from the last field or press **PAGE DOWN** to view the second page of service function key options:

```
SERVICE KEY PROG.↑
CALCULATE TAX3    Y←
CALCULATE TAX4    Y
COMPULSORY VALID  N
HARD CHECK PRINTER
  PORT (0-2)      0
```

3. Press **ENTER** from the last field to return to the **FUNCTION KEY PROGRAM** screen, or press **ESC** at any time to return to the **FUNCTION KEY PROGRAM** screen without saving changes.

SERVICE Key Program Notes

Option	Entry	Description
DESC	Alpha numeric 12 character	You can program a descriptor. The default descriptor is SERVICE.
NON-ADD # COMP	Y or N	Select Y if you wish to force the entry of a non-add number (i.e. a tax exempt #) before the key is used
PRINT ON RECEIPT	Y or N	Select N to not print on the receipt.
NEGATIVE BALANCE IN MGR CONTROL	Y or N	Select Y if you do not want the operator use this function in REGISTER mode. When selected, the function is allowed only in the X control lock position.
CALCULATE TAX1 CALCULATE TAX2 CALCULATE TAX3 CALCULATE TAX4	Y or N	Select Y to calculate and add the appropriate tax automatically when finalized with this key.
COMPULSORY VALIDATION	Y or N	Choose Y to enforce validation if an optional printer with validation capability is connected to an RS-232C port.
HARD CHECK PRINTER PORT (0-2)	0-2	If you are using a hard check system, enter the RS232C port number (1 or 2) where the optional guest check printer is attached.

TABLE

1. Press the **TABLE** key to view the table # function key options:

TABLE # PROG .	
DESC : TABLE	←
ENFORCE ON CHECK TRACK	N
ENFORCE ON ALL SALES	N
PRINT AT REMOTE PRINTER	N

2. Press **ENTER** from the last field to return to the **FUNCTION KEY PROGRAM** screen, or press **ESC** at any time to return to the **FUNCTION KEY PROGRAM** screen without saving changes.

TABLE Key Program Notes

Option	Entry	Description
DESC	Alpha numeric 12 character	You can program a descriptor. The default descriptor is TABLE.
ENFORCE ON CHECK TRACK	Y or N	If Y , you must enter the table number before opening a new check track #.
ENFORCE ON ALL SALES	Y or N	If Y , you must enter the table number before beginning any transaction.
PRINT AT REMOTE PRINTER	Y or N	Choose Y to print the table number at the remote printer.

TARE

1. Press the **TARE** key to view the Tare function key options:

```

TARE KEY PROG .
DESC : TARE          ←
KEY DISABLE          N
UNDER MGR CONTROL N
#5 IS MANUAL TARE N
  
```

2. Press **ENTER** from the last field to return to the **FUNCTION KEY PROGRAM** screen, or press **ESC** at any time to return to the **FUNCTION KEY PROGRAM** screen without saving changes.

TARE Key Program Notes

Option	Entry	Description
DESC	Alpha numeric 12 character	You can program a descriptor. The default descriptor is TARE.
KEY DISABLE	Y or N	Select Y to disable this function.
UNDER MGR CONTROL	Y or N	Select Y if you do not want the operator use this function in REGISTER mode. When selected, the function is allowed only in the X control lock position.
#5 IS MANUAL TARE	Y or N	Choose Y to use tare number five to manually enter a tare weight.

TAX EXEMPT

1. Press the **TAX EXEMPT** key to view the tax exempt function key options:

TAX EXEMPT PROG .		
DESC :	TAXEXMT	←
EXEMPT TAX 1		N
EXEMPT TAX 2		N
EXEMPT TAX 3		N
EXEMPT TAX 4		N
NON-ADD# COMP		N
COMPULSORY VALID		N

2. Press **ENTER** from the last field to return to the **FUNCTION KEY PROGRAM** screen, or press **ESC** at any time to return to the **FUNCTION KEY PROGRAM** screen without saving changes.

TAX EXEMPT Key Program Notes

Option	Entry	Description
DESC	Alpha numeric 12 character	You can program a descriptor. The default descriptor is TAXEXMT.
EXEMPT TAX 1 EXEMPT TAX 2 EXEMPT TAX 3 EXEMPT TAX 4	Y or N	Select Y or N for each tax to determine which tax or taxes are exempted when this key is used.
NON-ADD # COMP	Y or N	Select Y if you wish to force the entry of a non-add number (i.e. a tax exempt #) before the key is used.
COMPULSORY VALIDATION	Y or N	Choose Y to enforce validation if an optional printer with validation capability is connected to an RS-232C port.

TIME IN/OUT

1. Press the **TIME IN/OUT** key to view the time in/out function key options:

```

TIME IN/OUT PROG.
DESC : TIME IN/OUT ←
KEY DISABLE          N
UNDER MGR CONTROL  N
COMPULSORY VALID   N
    
```

2. Press **ENTER** from the last field to return to the **FUNCTION KEY PROGRAM** screen, or press **ESC** at any time to return to the **FUNCTION KEY PROGRAM** screen without saving changes.

TIME IN/OUT Key Program Notes

Option	Entry	Description
DESC	Alpha numeric 12 character	You can program a descriptor. The default descriptor is TIME IN/OUT .
KEY DISABLE	Y or N	Select Y to disable this function.
UNDER MGR CONTROL	Y or N	Select Y if you do not want the operator use this function in REGISTER mode. When selected, the function is allowed only in the X control lock position.
COMPULSORY VALIDATION	Y or N	Choose Y to enforce validation if an optional printer with validation capability is connected to an RS-232C port.

TIP

1. Press the **TIP** key to view the tip function key options:

TIP KEY PROG.	↓
DESC : TIP	←
KEY DISABLE	N
UNDER MGR CONTROL	N
TYPE IS	0
%:1 AMOUNT:0	
ADD TAX RATE 1	N
ADD TAX RATE 2	N

2. Press **ENTER** from the last field or press **PAGE DOWN** to view the second page of tip function key options:

TIP KEY PROG.	↑
ADD TAX RATE 3	N←
ADD TAX RATE 4	N
AMT ADDED TO	
NET & GROSS TOT	N

3. Press **ENTER** from the last field to return to the **FUNCTION KEY PROGRAM** screen, or press **ESC** at any time to return to the **FUNCTION KEY PROGRAM** screen without saving changes.

TIP Key Program Notes

Option	Entry	Description
DESC	Alpha numeric 12 character	You can program a descriptor. The default descriptor is TIP.
KEY DISABLE	Y or N	Select Y to disable this function.
TYPE IS %:1 AMOUNT:0	0 or 1	Select 0 if the tip is to be a calculated percentage based on a percentage entry. Select 1 if the TIP is to be an amount entry.
ADD TAX RATE 1 ADD TAX RATE 2 ADD TAX RATE 3 ADD TAX RATE 4	Y or N	Choose Y to if tax is to calculated and added on the tip amount.
AMT ADDED TO NET AND GROSS TOT	Y or N	Choose Y if you wish to add the TIP total to the NET and GROSS sales totals on the financial report.

VALIDATE

1. Press the **VALIDATE** key to view the validate function key options:

VALID KEY PROG.		
DESC :	VALIDATION	←
SLIP OUTPUT		
COM PORT # (0-2)		0
KEY DISABLE		N
ALLOW MULTIPLE		
VALID?		N

2. Press **ENTER** from the last field to return to the **FUNCTION KEY PROGRAM** screen, or press **ESC** at any time to return to the **FUNCTION KEY PROGRAM** screen without saving changes.

VALIDATE Key Program Notes

Option	Entry	Description
DESC	Alpha numeric 12 character	You can program a descriptor. The default descriptor is VALIDATION.
SLIP OUTPUT COMM PORT # (0-2)	0, 1, or 2	If validation is used, identify the communications port (1 or 2) where the validating printer is attached. Enter 0 if validation is not used.
KEY DISABLE	Y or N	Select Y to disable this function.
ALLOW MULTIPLE VALID?	Y or N	Select Y to allow multiple validations of the same transaction.

VOID ITEM

1. Press the **VOID ITEM** key to view the void item function key options:

```

VOID KEY PROG .
DESC : VOID      ←
KEY HALO          0.00
(0 : NO LIMIT)
KEY DISABLE      N
UNDER MGR CONTROL N
```

2. Press **ENTER** from the last field to return to the **FUNCTION KEY PROGRAM** screen, or press **ESC** at any time to return to the **FUNCTION KEY PROGRAM** screen without saving changes.

VOID ITEM Key Program Notes

Option	Entry	Description
DESC	Alpha numeric 12 character	You can program a descriptor. The default descriptor is VOID.
HALO	7 digit amount	You can limit errors by setting the maximum amount that can be used with this function. "0" means that there is no entry limit.
KEY DISABLE	Y or N	Select Y to disable this function.
UNDER MGR CONTROL	Y or N	Select Y if you do not want the operator use this function in REGISTER mode. When selected, the function is allowed only in the X control lock position.

WASTE

1. Press the **WASTE** key to view the waste function key options:

WASTE PROG.		
DESC :	WASTE	←
KEY HALO	0.00	
(0 : NO LIMIT)		
KEY DISABLE		N
UNDER MGR CONTROL		N
COMPULSORY VALID		N

2. Press **ENTER** from the last field to return to the **FUNCTION KEY PROGRAM** screen, or press **ESC** at any time to return to the **FUNCTION KEY PROGRAM** screen without saving changes.

WASTE Key Program Notes

Option	Entry	Description
DESC	Alpha numeric 12 character	You can program a descriptor. The default descriptor is WASTE.
HALO	7 digit amount	You can limit errors by setting the maximum amount that can be used with this function. "0" means that there is no entry limit.
KEY DISABLE	Y or N	Select Y to disable this function.
UNDER MGR CONTROL	Y or N	Select Y if you do not want the operator use this function in REGISTER mode. When selected, the function is allowed only in the X control lock position.
COMPULSORY VALIDATION	Y or N	Choose Y to enforce validation if an optional printer with validation capability is connected to an RS-232C port.

Logo Descriptor

- ◆ From the **PGM** control lock position menu, press **7** for **LOGO DESC.** The **LOGO DESC. PROGRAM** screen displays:

```
LOGO DESC. PROGRAM
0. PREAMBLE
1. POSTAMBLE
2. ENDORSEMENT MMSG.
3. FINANCIAL REPORT
4. CLERK REPORT
5. MACRO NAME
```

Preamble

The preamble is a programming message of up to six lines of 32 characters that appears at the top of each receipt and/or guest check.

1. From the **LOGO DESC. PROGRAM** screen, press **0** to display the **PREAMBLE** screen:

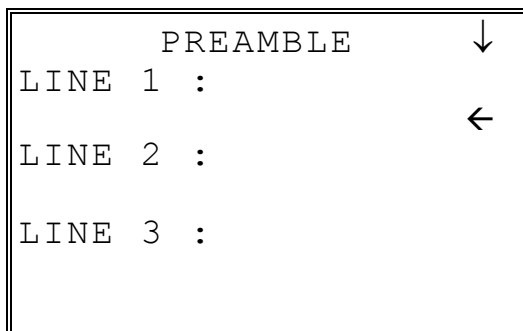

```
      P R E A M B L E      ↓
L I N E  1  :
                               ←
L I N E  2  :
L I N E  3  :
```

2. Using the alpha numeric keyboard overlay, type the first line of the message. You can also program by using the descriptor code method (see page 117.) Each line can be up to 32 characters, although only the last 19 characters you have entered will display. If you make a mistake, press the **BACKSPACE** key to erase the previous character. After you have completed typing the first line, press **ENTER** to accept the new line and advance to the second line, or press **ESC** to return to the **LOGO DESC. PROGRAM** screen without making any changes.
3. Using the same procedure, continue programming each line as necessary. Press **ESC** at any time to exit. After programming the third line, the fourth, fifth, and sixth lines display:

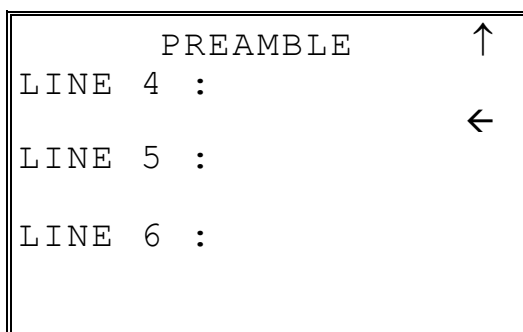

```
      P R E A M B L E      ↑
L I N E  4  :
                               ←
L I N E  5  :
L I N E  6  :
```

4. When the last line has been entered, press **ENTER** to accept the line and return to the **LOGO DESC. PROGRAM** screen.

Postamble

The postamble is a programming message of up to six lines of 32 characters that appears at the bottom of each receipt and/or guest check.

1. From the **LOGO DESC. PROGRAM** screen, press **0** to display the **POSTAMBLE** screen:

```
          POSTAMBLE      ↓
LINE 1  :
                               ←
LINE 2  :
LINE 3  :
```

2. Using the alpha numeric keyboard overlay, type the first line of the message. You can also program by using the descriptor code method (see page 117.) Each line can be up to 32 characters, although only the last 19 characters you have entered will display. If you make a mistake, press the **BACKSPACE** key to erase the previous character. After you have completed typing the first line, press **ENTER** to accept the new line and advance to the second line, or press **ESC** to return to the **LOGO DESC. PROGRAM** screen without making any changes.
3. Using the same procedure, continue programming each line as necessary. Press **ESC** at any time to exit. After programming the third line, the fourth, fifth and sixth lines display:

```
          POSTAMBLE      ↑
LINE 4  :
                               ←
LINE 5  :
LINE 6  :
```

4. When the last line has been entered, press **ENTER** to accept the line and return to the **LOGO DESC. PROGRAM** screen.

Endorsement Message

The Endorsement Message is a programming message of up to ten lines of 32 characters that prints when a check is endorsed on an optional slip printer.

1. From the **LOGO DESC. PROGRAM** screen, press **2** to display the **ENDORSEMENT MESG.** Screen:

```
ENDORSEMENT MESG. ↓
LINE 1  :
                                           ←
LINE 2  :
LINE 3  :
```

2. Using the alpha numeric keyboard overlay, type the first line of the message. You can also program by using the descriptor code method (see page 117.) Each line can be up to 32 characters, although only the last 19 characters you have entered will display. If you make a mistake, press the **BACKSPACE** key to erase the previous character. After you have completed typing the first line, press **ENTER** to accept the new message and advance to the second line, or press **ESC** to return to the **LOGO DESC. PROGRAM** screen without making any changes.
3. Using the same procedure, continue programming each line as necessary. Press **ESC** at any time to exit. After programming the third line, the next three lines display:

```
ENDORSEMENT MESG. ↑
LINE 4  :
                                           ←
LINE 5  :
LINE 6  :
```

4. Continue programming all ten lines if necessary. When the last line has been entered, press **ENTER** to accept the message and return to the **LOGO DESC. PROGRAM** screen.

Financial Report

The Financial Report selection allows you to reprogram the descriptors that appear with the Financial Report totals and counters. For example, the first total on the financial report "+PLU TTL" represents the total of all positive PLU entries. You might wish to re-label this total to say "FOOD SALES". You can reprogram any of the Financial Report totals listed here with any 12-character descriptor.

1. From the **LOGO DESC. PROGRAM** screen, press **3** to display the **FINANCIAL REP MESSG.** Screen:

```
FINANCIAL REP MESSG. ↓
TTL 1 :
+PLU TTL ←
TTL 2 :
-PLU TTL
TTL 3 :
ADJST TTL
```

2. The first 3 report descriptors (TTLs 1-3) display with the cursor arrow pointing at the first descriptor. Using the alpha numeric keyboard overlay, type the descriptor. You can also program by using the descriptor code method (see page 117.) Each descriptor can be up to 12 characters. If you make a mistake, press the **BACKSPACE** key to erase the previous character. After you have completed typing the first descriptor, press **ENTER** to accept the new message and advance to the TTL, or press **ESC** to return to the **LOGO DESC. PROGRAM** screen without making any changes.
3. Press **ENTER** repeatedly, or press **PAGE UP** and/or **PAGE DOWN** to locate the next descriptor you wish to program. After the last item on each screen, the screen shifts to display the next 3 descriptors. (There are 73 Financial Report descriptors that you may program.) Using the same procedure, continue programming each line as necessary. Press **ESC** at any time to exit and return to the **LOGO DESC. PROGRAM** screen.

Clerk Report

The Clerk Report selection allows you to reprogram the descriptors that appear with the Clerk Report totals and counters. For example, the first total on the clerk report "NET SALES" might be re-labeled to say "GROSS SALES". You can reprogram any of the Financial Report totals listed here with any 12-character descriptor.

1. From the **LOGO DESC. PROGRAM** screen, press **4** to display the **CLERK REP MSG.** Screen:

```
CLERK REP MSG. ↓
TTL 1 :
NET SALE ←
TTL 2 :
NONTAX
TTL 3 :
TAX1 SALES
```

2. The first 3 report descriptors (TTLs 1-3) display with the cursor arrow pointing at the first message. Using the alpha numeric keyboard overlay, type the descriptor. You can also program by using the descriptor code method (see page 117.) Each descriptor can be up to 12 characters. If you make a mistake, press the **BACKSPACE** key to erase the previous character. After you have completed typing the first descriptor, press **ENTER** to accept the new message and advance to the TTL, or press **ESC** to return to the **LOGO DESC. PROGRAM** screen without making any changes.
3. Press **ENTER** repeatedly, or press **PAGE UP** and/or **PAGE DOWN** to locate the next descriptor you wish to program. After the last item on each screen, the screen shifts to display the next 3 descriptors. (There are 52 Clerk Report descriptors that you can program.) Using the same procedure, continue programming each line as necessary. Press **ESC** at any time to exit and return to the **LOGO DESC. PROGRAM** screen.

Macro Name

Up to ten function locations may be designated as Macro keys. You may wish to program a name for a macro if the macro function appears on a function look-up key. For example if a macro executes a series of commands to produce daily reports, you can program the descriptor "DAILY", so the macro can easily be identified when it appears on the function look up key. Macro names can also be helpful when looking at keyboard layout information with the PC communication utility, *SAM 65*.

1. From the **LOGO DESC. PROGRAM** screen, press **5** to display the **MACRO NAME** Screen:

```
MACRO NAME DESC. ↓
MACRO 1 :
MACRO1 ←
MACRO 2 :
MACRO2
MACRO 3 :
MACRO3
```

2. Using the alpha numeric keyboard overlay, type the descriptor. You can also program by using the descriptor code method (see page 117.) Each descriptor can be up to 12 characters. If you make a mistake, press the **BACKSPACE** key to erase the previous character. After you have completed typing the first descriptor, press **ENTER** to accept the new message and advance to the TTL, or press **ESC** to return to the **LOGO DESC. PROGRAM** screen without making any changes.
3. Press **ENTER** repeatedly, or press **PAGE UP** and/or **PAGE DOWN** to locate the next macro descriptor you wish to program. After the last item on each screen, the screen shifts to display the next 3 macro descriptors. Using the same procedure, continue programming each line as necessary. Press **ESC** at any time to exit and return to the **LOGO DESC. PROGRAM** screen.

NLU Code Number

NLUs are fixed keys on the keyboard (like traditional department keys) that access specific PLUs.

On the default keyboard, there are 30 NLU keys and the PLU# assigned to the NLU key is the same, i.e. NLU key number one is PLU #1. However, with this program, you can assign any PLU number you wish to any one of the 80 possible NLU keys.

1. From the **PGM** control lock position menu, press **8** for **NLU CODE# PGM**. The **NLU CODE PROGRAM** screen displays:

```
NLU CODE PROGRAM

PRESS THE NLU KEY ON
THE KEYBOARD YOU
WISH TO PROGRAM

PRESS ESC TO EXIT
```

2. Press the NLU key on the keyboard you wish to program, or press **ESC** to exit.

```
NLU CODE PROGRAM

CURRENT PLU CODE#
                               1
ENTER
NEW PLU CODE#
                               0←
```

3. The current PLU code number displays. Type the new PLU code number you wish to use for this NLU key, press **ENTER**.
4. The **NLU CODE PROGRAM** screen returns. Continue from step 2 to program additional NLU keys, or press **ESC** to exit.

Download Programs

When multiple registers are connected in an IRC network, you can download programs from one register to any or all of the remaining registers.

1. From the **PGM** control lock position menu, press **9** for **DOWNLOAD PROGRAMS**. The **PROGRAM DOWN** screen displays:

```
PROGRAM DOWN
0 . IRC ALL
1 . IRC SELECT
```

2. From the **PROGRAM DOWN** screen, press **0** if you wish to download programs to all of the registers, then go to step 4. If you wish to download only to selected registers, press **1**:

```
PROGRAM DOWN
0 . IRC ALL
1 . IRC SELECT

#  1  2  3  4  5  6  7  8
  Y←Y  Y  N  N  N  N  N
```

3. If you pressed **1** to download to selected registers, the **PROGRAM DOWN** screen now displays **Y** or **N** for each of the eight possible registers in an IRC system. For example, if your IRC system consists of 3 registers, the default **Y** will display for register 1, 2, and 3. The cursor arrow points at the first register. Press the **YES/NO** key to toggle the selection for register #1 to **Y** or **N**. Press **ENTER**. The cursor arrow moves to #2. Select **Y** or **N** for second register. In this manner you can determine which registers you wish to download programs to. When you have selected **Y** or **N** for the last register, the **PROGRAM DOWN** screen appears.

```
PROGRAM DOWN ↓
0 . PLU
1 . GROUP
2 . SALES TAX
3 . SYSTEM OPTION
4 . PRINT OPTION
5 . FUNCTION KEYS
6 . CLERK
```

4. From the **PROGRAM DOWN** screen, find the digit that represents the program you wish to download. Press **PAGE DOWN** to view the second page of the **PROGRAM DOWN** options. Note that **00** downloads all programs.

```
PROGRAM DOWN ↑
7 . LOGO DESC .
8 . NLU CODE# PGM .
9 . TIME & DATE/MISC
00 . ALL
```

5. Press the digit that represents your selection. This display will indicate the number of the machine that the program is downloading to. The printer at the receiving register will indicate "PROGRAM DOWN" and "PASS" or "FAIL" to indicate if the download is successful.

Note: If there is a failure in IRC communication, the register that programs are being sent from will display "TIME OVER" indicating that the IRC retries have been completed and no communication was possible.

Clerk In/Out

The Clerk In/Out program allows you to edit actual punch in/out times for the day.

1. From the **PGM** control lock position menu, press **00** for **MORE**. The **PROGRAM MODE page 2** screen displays.
2. From the **PROGRAM MODE page 2** screen, press **0** for **CLERK I/O**. The **CLERK NUMBER** screen displays:

```
CLERK NUMBER
CLERK NO? (1-??) 0←
```

3. Type the number of the clerk you wish to edit and press **ENTER** to display the **CLERK I/O PROG.** screen:

```
CLERK I/O PROG.
IN 00.00.00← 00:00
OUT 00.00.00 00:00
IN 00.00.00 00:00
OUT 00.00.00 00:00
IN 00.00.00 00:00
OUT 00.00.00 00:00
TIME WORKED: 00:00
```

4. The cursor will point at the date for the first time punch. Press **ENTER** until the cursor points at the field you wish to edit. Note that you can edit the last 20 time punches, although only 6 dates/times display on the screen at one time. When you leave the last field displayed on the current screen, your view will shift to the next 6 dates/times
 - If you wish to edit a date, type a new date and press **ENTER**. Be sure to enter the date in a six digit format, i.e. enter July 8th, 1999 as **070899**.
 - If you wish to edit a time field, type the new time in a 24 hour (military) format, i.e. enter 7:00 PM as **1900**.
5. Note that when you edit time information, the **TIME WORKED** field is updated with a new total. When you have completed editing, press **ESC** to return to the **CLERK NUMBER** selection screen.

PLU Stock

If you designate a PLU as an inventory item (see PLU programming) then a special PLU stock counter keeps a running inventory count. This program is where you can set the current inventory level.

- Refer to "System Option Programming" on page 142 to determine whether the quantity of inventory you enter in this program adds to existing inventory quantity, or whether it replaces the current inventory quantity.
- Inventory is kept in decimal units two digits beyond the decimal. For example, if 1.75 pounds are multiplied times the PLU with the preset price per pound of apples, 1.75 is subtracted from the PLU representing apples.

To Program Inventory

1. From the **PGM** control lock position menu, press **00** for **MORE**. The **PROGRAM MODE page 2** screen displays.
2. From the **PROGRAM MODE page 2** screen, press **1** for **PLU STOCK**. The **PLU NUMBER** screen displays:

```
PLU NUMBER
* ENTER PLU NUMBER
AND PUSH PLU, OR
* PRESS A PLU KEY ON
THE KEYBOARD

0 ←
```

3. Enter the PLU number and press the PLU key, or press an PLU key on the keyboard. The stock quantity for the selected PLU displays:

```
PLU#           1 P1
STOCK QUANTITY
                0.00 ←
```

4. Type the new or additional stock quantity and press **ENTER**. Note that stock is kept in decimal units and you must enter new or additional stock to two digits beyond the decimal. For example, type **1 0 0 0** to enter ten units of inventory.
5. Return to step 2 to continue recording inventory, or press **ESC** to return to the **PROGRAM MODE** menu.

Drawer Limit

You can set a limit for cash in drawer. When cash in drawer exceeds the limit you program here, a warning will display on the screen. You must press **CLEAR** to remove the warning and continue operations. The warning will continue to appear at the completion of every transaction with the limit exceeded, until you use the **PAID OUT** function to remove cash from the drawer.

Set the drawer limit to **0** to disable the drawer limit warning.

1. From the **PGM** control lock position menu, press **00** for **MORE**. The **PROGRAM MODE page 2** screen displays.
2. From the **PROGRAM MODE page 2** screen, press **2** for **DRAWER LIMIT**. The **LIMIT PROGRAM** screen displays:

LIMIT PROGRAM	
DRAWER LIMIT	0.00←

3. Type the amount you wish to use for a limit (or type 0 for no limit.) Press **ENTER**.

Check Change Limit

Use this program to set the maximum amount of cash that can be returned when a check is tendered for an amount greater than the amount of the sale. For example, if the check change limit is \$10.00 the maximum amount that can be tendered into the check key on a \$5.00 sale is \$15.00.

1. From the **PGM** control lock position menu, press **00** for **MORE**. The **PROGRAM MODE page 2** screen displays.
2. From the **PROGRAM MODE page 2** screen, press **3** for **CHECK CHANGE LIMIT**. The **CHECK LIMIT PGM.** screen displays:

CHECK LIMIT PGM.

CHECK CHANGE LIMIT
0.00←

3. Type the amount for the check change limit. Press **ENTER**.

Time & Date

Use this program to set the clock and calendar on your *ER-650/650R*. The date changes automatically. After initial setting, time changing will probably be required only for beginning and ending daylight savings time.

1. From the **PGM** control lock position menu, press **00** for **MORE**. The **PROGRAM MODE page 2** screen displays.
2. From the **PROGRAM MODE page 2** screen, press **4** for **TIME & DATE**. The **SET DATE & TIME** screen displays:

```
SET DATE & TIME

SET TIME :      HH:MM
(MILITARY)    09:01←

SET DATE : MM.DD.YY
              09.21.99
```

3. Type the current time in 24-hour format (i.e. military time, where 13:00 is 1:00 PM.) Press **ENTER**.
4. Type the current date in MM (month) DD (day) and YY (year) format. Press **ENTER**.

Tare Weight

A tare is the amount of weight representing the container, or package when items are sold by weight. You can pre-program five tare weights, representing the weight of different containers. When you place an item and a container on an optional scale, you can enter the tare number to automatically subtract the pre-programmed tare weight.

If you choose to use tare #5 for manual tare weight entry, do not enter a weight for tare #5. (See TARE on page 202.)

1. From the **PGM** control lock position menu, press **00** for **MORE**. The **PROGRAM MODE page 2** screen displays.
2. From the **PROGRAM MODE page 2** screen, press **5** for **TARE WEIGHT**. The **TARE WEIGHT PROG.** screen displays with the cursor arrow pointed at the weight for tare #1:

TARE WEIGHT PROG.		
TARE 1 :	0.000	←
TARE 2 :	0.000	
TARE 3 :	0.000	
TARE 4 :	0.000	
TARE 5 :	0.000	

3. Type the weight for the first tare, press **ENTER**. The cursor advances to TARE 2. Type the weight for the second tare and press **ENTER**. Continue until all 5 tares are programmed, or press **ESC** to exit.

Macro

Macro keys may be programmed to record, and then later perform, up to 50 keystrokes. For example, a macro key could be set to tender (preset tender) a common currency, such as \$5 into the cash key. Use this program to record keystrokes for each of the 10 possible macro keys.

Note: You can also program macros in function key programming.

1. From the **PGM** control lock position menu, press **00** for **MORE**. The **PROGRAM MODE page 2** screen displays.
2. From the **PROGRAM MODE page 2** screen, press **6** for **MACRO**. The **MACRO PROGRAM** screen displays:

	MACRO	PROGRAM	
0 .	MACRO	# 1	
1 .	MACRO	# 2	
2 .	MACRO	# 3	
3 .	MACRO	# 4	
4 .	MACRO	# 5	
5 .	MACRO	# 6	
6 .	MACRO	# 7	↓

3. Press the digit that represents the macro you wish to program. Press **PAGE DOWN** to view the remainder of the list:

	MACRO	PROGRAM	↑
7 .	MACRO	# 8	
8 .	MACRO	# 9	
9 .	MACRO	# 10	

Programming a New Macro

1. After selecting a new macro to program, the screen displays with the arrow pointing at the first macro line:

```
1 . ←  
2 .  
3 .  
4 .  
5 .  
6 .  
7 .  
8 .
```

2. Press the first key of the macro sequence, for example, press **1** (numeric one):

```
1 . ONE ←  
2 .  
3 .  
4 .  
5 .  
6 .  
7 .  
8 .
```

3. The keystroke is recorded on the screen and the cursor moves to the next keystroke.

- Continue to enter keystrokes until the macro is complete. Press **ESC** to end the macro recording and return to the **MACRO PROGRAM** screen. If you wish to add a function to a macro that is not located on the keyboard, or if you wish to include the **CLEAR/ESC**, **Y/N**, **PAGE UP**, or **PAGE DOWN** function to a macro string (these keys are used for editing purposes inside this program), press **PAGE DOWN** to display a keycode list:

FUNCTION	KEYCODE

NLU#1 - NLU#80 (1-80)	
ONE	81
TWO	82
THREE	83
FOUR	84
FIVE	85

- With the keycode list displayed, press **PAGE DOWN** and **PAGE UP** to find the function you wish to add to the macro. Type the numeric code number press **ENTER**. The function is added to the macro.

Editing an Existing Macro

- After selecting a macro to program the screen displays the keystrokes currently programmed.

1 . ONE	←
2 . TWO	
3 . THREE	
4 . FOUR	
5 .	
6 .	
7 .	
8 .	

- Press the **YES/NO** key to advance the cursor to the line you wish to edit.
- With the cursor pointing at a line, press (or select) the new function you wish to place in the macro sequence.
- If you wish to remove a key stroke from a macro, replace the current function with the **INACTIVE** function by pressing the **PAGE DOWN** to display a keycode list, then enter **1 8 7**.

Machine No.

The machine number is printed on the register receipt. Program a machine number so that any receipt can be identified with the store or register where the transaction took place. The machine number may be a different number than the IRC register number programmed in IRC programming (see "IRC Options" in the "Service Mode Programming" chapter.)

1. From the **PGM** control lock position menu, press **00** for **MORE**. The **PROGRAM MODE page 2** screen displays. Press **PAGE DOWN** to view the remainder of the page 2 program options.
2. From the **PROGRAM MODE page 2** screen, press **7** for **MACHINE NO**. The **MACHINE # PROG.** screen displays:

MACHINE # PROG.		
MACHINE #		0 ←

3. Type the machine number, up to 5 digits, press **ENTER**.

PC Schedule Time

To be polled by a PC, the register must be placed in the PC ONLINE MODE.

You can place the PC in ONLINE MODE manually by selecting the PC COMMUNICATION function from the RESET REPORT MODE menu. If you wish to do unattended polling, you can program the *ER-650/650R* to automatically enter the PC ONLINE MODE at a scheduled time.

You must also configure one of the RS232C ports for PC communications. See the "Service Mode Programming" chapter in this manual.

1. From the **PGM** control lock position menu, press **00** for **MORE**. The **PROGRAM MODE page 2** screen displays. Press **PAGE DOWN** to view the remainder of the page 2 program options.
2. From the **PROGRAM MODE page 2** screen, press **8** for **PC SCHEDULE TIME**. The **PC SCHEDULE PROG.** screen displays:

```
PC SCHEDULE PROG.  
  
SET TIME :      HH:MM  
(MILITARY)    00:00←
```

3. Type the time you wish to enter PC Communication mode, press **ENTER**.

Note: PC polling cannot be performed without optional polling software. Please contact your authorized dealer for information.

Training Mode Password

If you wish to use training mode, you must program a password that you will use to enter training mode. The password may be up to 4 digits long, however, if you choose to use a password less than 4 digits, you must enter preceding zeros to complete a 4 digit entry. For example, if you program the password to be "77", you must type "0077" when entering training.

1. From the **PGM** control lock position menu, press **00** for **MORE**. The **PROGRAM MODE page 2** screen displays. Press **PAGE DOWN** to view the remainder of the page 2 program options.
2. From the **PROGRAM MODE page 2** screen, press **9** for **TRAINING MODE P/W**. The **TRAINING MODE P/W** screen displays:

TRAINING MODE P/W

PASSWORD : 0 ←

3. Type the password, up to 4 digits, press **ENTER**.

Program Scans

You can make a printed record of your *ER-650/650R* program.

1. From the **PGM** control lock position menu, press **00** for **MORE**. The **PROGRAM MODE page 2** screen displays. Press **PAGE DOWN** to view the remainder of the page 2 program options.
2. From the **PROGRAM MODE page 2** screen, press **00** for **SCAN**. The **PROGRAM SCAN** screen displays:

```
PROGRAM SCAN
0 . PROGRAM SCAN
1 . ALL PGM SCAN
```

3. Press **1** to initiate a printout of all programs. Press **0** to select the program you wish to print from the **PROGRAM SCAN** screen.

```
PROGRAM SCAN ↓
0 . PLU
1 . GROUP
2 . SALES TAX
3 . SYSTEM OPTION
4 . PRINT OPTION
5 . FUNCTION KEYS
6 . CLERK
```

4. Press **PAGE DOWN** to view the remainder of the program scan selections. If you see the program you wish to print, press the digit representing that program.

```
PROGRAM SCAN ↑
7 . LOGO DESC .
8 . NLU CODE# PGM .

00 . MORE SCAN
```

5. Press **00** to view the **PROGRAM SCAN page 2** screen:

```
PROGRAM SCAN page2↓
0.CLERK I/O
1.PLU STOCK
2.DRAWER LIMIT
3.CHECK CHANGE LIMIT
4.TIME & DATE
5.TARE WEIGHT
6.MACRO
```

6. Press **PAGE DOWN** to view the remainder of the program scan selections. When you see the program you wish to print, press the digit representing that program.

```
PROGRAM MODE page2↑
7.MACHINE NO.
8.PC SCHEDULE
9.TRAINING MODE P/W
```

Sample Reports

Financial

Total and count of all positive PLUs	→	DATE 11/10/1999 WED TIME 13:32
Total and count of all Negative PLUs	→	X 1 REPORT 00001
Total of +PLU and -PLU sales	→	-----
Total of Non-taxable sales	→	FINANCIAL
Total of tax eligible sales for each sale tax	→	+PLU TTL 179.56
Total of tax collected for each tax	→	\$288.60
Total exempted sales for each tax	→	-PLU TTL 10
Total sales for each type of destination	→	-20.00
Total and count for each % function key (i.e. discounts & coupons)	→	ADJST TTL 189.56
		\$268.60

		NONTAX \$30.47
		TAX1 SALES \$153.60
		TAX2 SALES \$11.92
		TAX3 SALES \$16.77
		TAX4 SALES \$31.89
		TAX1 \$10.00
		TAX2 \$1.21
		TAX3 \$1.18
		TAX4 \$2.18
		XMPT1 SALES \$7.00
		XMPT2 SALES \$1.50
		XMPT3 SALES \$7.95
		XMPT4 SALES \$7.50
		EATIN TTL 1
		\$10.12
		TAKEOUT TTL 2
		\$40.77
		DRTHRU TTL 1
		\$3.04
		ITEM DISC. 3
		-0.48
		continued . . .

continued from previous page

Total and count for each % function key (i.e. discounts & coupons)

Net Sales

Credited tax for each tax. (Tax is credited for negative taxable sales, i.e. mdse return transactions.)

Food stamp change credited to sales

Total and count for each type of transaction correction.

Gross Sales

Totals and counters for CASH and CHECK sales

Total and count for each type R/A (received on account) and P/O (paid out) key.

SALE DISC.	2
	-5.22
SALE SURCH.	3
	\$3.23
% 4	0
	\$0.00
% 5	0
	\$0.00
NET SALE	26
	\$281.18
CREDIT TAX1	4
	-1.11
CREDIT TAX2	1
	-0.23
CREDIT TAX3	2
	-0.89
CREDIT TAX4	1
	-0.39
FD/S CREDIT	0
	\$0.23
RETURN	33
	-59.73
ERROR CORR	2
	-4.00
PREVIOUS VD	1
	-1.50
MODE VOID	-2
	-6.40
CANCEL	2
	\$16.00
GROSS SALES	\$375.63
CASH SALES	13
	\$133.49
CHECK SALES	1
	\$23.05
R/A 1	1
	\$145.00
R/A 2	0
	\$0.00
R/A 3	0
	\$0.00
P/O 1	1
	-140.00
P/O 2	0
	\$0.00
P/O 3	0
	\$0.00

continued . . .

Total and count of items sold with HASH status.

Count of No Sales.

Total of numbers entered into the non-add key

Total and count of expected CASH, CHECK in drawer

Total and count of expected in drawer for each charge function. (Charge in drawer will differ from charge sales if the charge is over-tendered

Total and count for each CHARGE key.

Total for each Foreign currency in drawer.

continued from previous page

HASH TTL	0
	\$0.00
NOSALE	4
NON ADD #	547
CASH-IN-D	14
	\$269.99
CHECK-IN-D	3
	-108.45
FD/S-IN-D	2
	\$21.00
CHG1-IN-D	0
	\$0.00
CHG2-IN-D	1
	\$8.43
CHG3-IN-D	1
	\$8.52
CHG4-IN-D	2
	-1.60
CHG5-IN-D	1
	\$2.67
CHG6-IN-D	2
	\$13.09
CHG7-IN-D	0
	\$0.00
CHG8-IN-D	1
	\$3.04
CHG1 SALES	0
	\$0.00
CHG2 SALES	1
	\$8.43
CHG3 SALES	1
	\$8.52
CHG4 SALES	2
	-1.60
CHG5 SALES	1
	\$2.67
CHG6 SALES	2
	\$13.09
CHG7 SALES	0
	\$0.00
CHG8 SALES	1
	\$3.04
FOREIGN 1	0.00
FOREIGN 2	0.00
FOREIGN 3	0.00
FOREIGN 4	0.00

continued . . .

Total of CASH, CHECKS and CHARGES in drawer.

Total and count for PROMO and WASTE.

Number of transactions and total activity in Training Mode

Total and count of balances entered into PBAL key

Total and count of balances paid

Total and count of items serviced

Average number if items per customer, and average dollar sales per customer

Grand total

continued from previous page

DRWR TTL	\$216.69
PROMO	1
	\$1.50
WASTE	8
	\$12.50
TRAIN TTL	5
	\$62.59
BAL FORWARD	4
	\$88.13
GUESTS	5
P/BAL	4
	\$0.00
CHECKS PAID	2
	\$18.64
SERVICE	4
	\$88.13
AVG ITEM/CUST	7.29
AVG \$/CUST	\$10.81

GRAND	\$375.63
ETHAN	No.000209 00000

Total number of guests served

Total and count of all balances serviced

Time

Time Period

Number of Transactions

Net sales in this period.

Percentage of total sales

Number of Transactions all periods

Net sales in all periods.

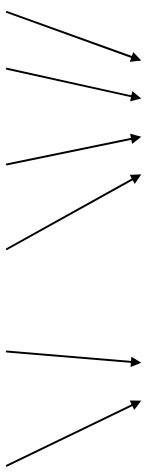

```
DATE 11/10/1999 WED    TIME 15:48
X 1  REPORT              00001
-----
TIME
13:00-13:59
CNT                      17
SALES AMT                $183.85
SALES RATE                65.39%
14:00-14:59
CNT                      9
SALES AMT                $97.33
SALES RATE                34.61%
*****
TOTAL CNT                 26
TOTAL AMT                $281.18
ETHAN                    No.000236  00000
```

PLU

PLU number

PLU Descriptor

Count and sales total.

Percentage of total sales

```

DATE 11/10/1999 WED   TIME 15:33
X 1  REPORT              00001
-----
ALL PLU
PLU#1
HAMBURGER
  CNT 28                $42.00
  SALES RATE            15.64%
PLU#2
DBL BURGER
  CNT 40                $99.75
  SALES RATE            37.14%
PLU#4
COKE
  CNT 26                $38.85
  SALES RATE            14.46%
PLU#5
SPRITE
  CNT 18                $13.42
  SALES RATE             5.00%
PLU#7
ROAST
  CNT 19.16             $30.47
  SALES RATE            11.34%
PLU#28
UNLEADED
  CNT 32.85             $39.39
  SALES RATE            14.66%
PLU#29
RETURNS
  CNT 10                -20.00
  SALES RATE            -7.44%
PLU#33
NAILS
  CNT 15.55             $24.72
  SALES RATE             9.20%
*****
TOTAL CNT                189.56
TOTAL AMT                $268.60
ETHAN                    No.000213  00000
  
```

Total activity for all PLUs

Total sales for all PLUs.

Clerk

Note: Media totals can be printed for each clerk, if selected in System Option Programming.

Clerk Name

Number of Transactions

Net sales for this clerk

Drawer total for this clerk

DATE 11/10/1999 WED	TIME 15:36
X 1 REPORT	00001

ALL CLERK	
ETHAN	
NET SALE	10
	\$155.23
DRWR TTL	\$109.81

ZACH	
NET SALE	5
	\$45.14
DRWR TTL	\$43.22

ANNA	
NET SALE	4
	\$78.75
DRWR TTL	\$67.03

LAURA	
NET SALE	2
	\$0.00
DRWR TTL	\$18.64

PEGGY	

MOLLY	
NET SALE	5
	\$2.06
DRWR TTL	-22.01

ETHAN	No.000218 00000

Individual Clerk

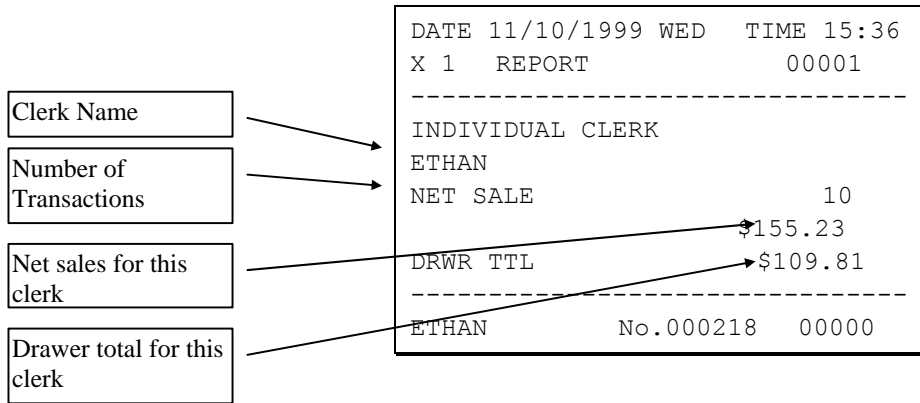

Groups

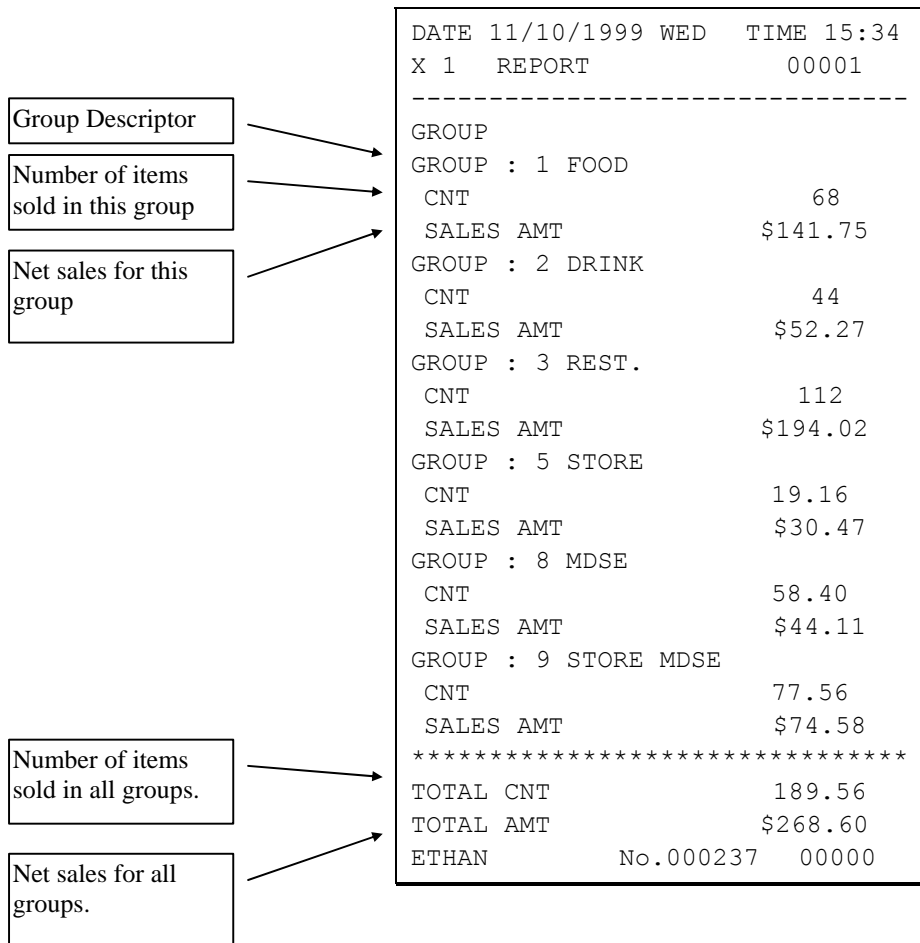

Stock

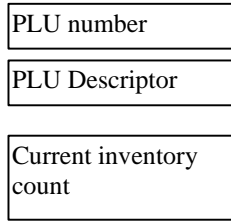

```
DATE 11/10/1999 WED   TIME 15:47
X 1  REPORT              00001
-----
ALL PLU STOCK
PLU#1
HAMBURGER
  CNT                26
PLU#2
DBL BURGER
  CNT                15
PLU#7
ROAST
  CNT                25.96
PLU#28
UNLEADED
  CNT               1488.47
PLU#33
NAILS
  CNT                161.25
ETHAN      No.000228  00000
DATE 11/10/1999 WED   TIME 15:47
```

Clerk Time Report

Clerk Name

Date and time for the last ten time clock punches (in & out)

Total time for clerk

Total time for all clerks

```

DATE 11/10/1999 WED    TIME 15:36
X 1  REPORT              00001
-----
INDIVI. CLERK TIME
ETHAN
TIME IN :    11/09/1999  07:52
TIME OUT:    11/09/1999  15:44
TIME IN :    11/10/1999  07:52
TIME OUT:    11/10/1999  13:50
TIME WORKED :                0013:50
ZACH
TIME IN :    11/09/1999  07:26
TIME OUT:    11/09/1999  14:55
TIME IN :    11/10/1999  07:26
TIME OUT:    11/10/1999  14:22
TIME IN :    11/11/1999  06:58
TIME WORKED :                0014:25
ANNA
TIME IN :    11/09/1999  12:52
TIME OUT:    11/09/1999  15:42
TIME IN :    11/10/1999  06:44
TIME OUT:    11/10/1999  14:55
TIME WORKED :                0011:01
LAURA
TIME IN :    11/09/1999  02:33
TIME OUT:    11/09/1999  07:55
TIME IN :    11/09/1999  12:44
TIME OUT:    11/09/1999  18:44
TIME IN :    11/10/1999  09:55
TIME WORKED :                0011:22
PEGGY
TIME IN :    11/10/1999  13:52
TIME WORKED :                0000:00
MOLLY
TIME IN :    11/09/1999  01:05
TIME OUT:    11/09/1999  09:55
TIME IN :    11/10/1999  07:44
TIME WORKED :                0008:50
-----
TOTAL WORKED :                0059:28
ETHAN          No.000217  00000
    
```

Check File

Open check number
and balance.

Clerk responsible
for the check.

```
DATE 11/10/1999 WED   TIME 15:59
X 1  REPORT           00001
-----
OPEN CHECK
CHECK : 3              $24.07
MOLLY
CHECK : 4              $45.42
ETHAN
CHECK : 5              $24.50
ETHAN
CHECK : 6              $28.33
ETHAN
ETHAN                   No.000243  00000
```

PLU Zero Sale

DATE 11/10/1999 WED TIME 15:59		
X 1 REPORT 00001		

PLU ZERO SALE		

ITEM		PLU#

PLU11		#11
PLU14		#14
PLU15		#15
PLU16		#16
PLU19		#19
PLU20		#20
CLERK 1 No.000243 00000		

Diagram labels and arrows:

- A box labeled "PLU Descriptor" has an arrow pointing to the "ITEM" column header.
- A box labeled "PLU Number" has an arrow pointing to the "PLU#" column header.

Balancing Formulas

+/-	Net Sales	\$ Example
=	PLU Sales Total	\$
+	Tax 1	\$
+	Tax 2	\$
+	Tax 3	\$
+	Tax 4	\$
+	Sale Coupon Amounts	\$
+	Sale Percent Discounts	\$
+	Sale Surcharge Amounts	\$
=	Net Sales	\$

+/-	Gross Sales	\$ Example
=	Net Sales	\$
+	Negative PLU Total	\$
+	Item Coupon Total	\$
+	Item Percent Discount	\$
+	Sale Coupon Amounts	\$
+	Sale Percent Discounts	\$
+	Credit Tax 1	\$
+	Credit Tax 2	\$
+	Credit Tax 3	\$
+	Credit Tax 4	\$
+	Merchandise Return	\$
+	Void Position Total	\$
=	Gross Sales	\$

Glossary of Terms

Activity Count

The activity counter keeps track of the number of times an entry is made on a PLU, or function key.

Alpha Keyboard Overlay

The alpha keyboard overlay represents a new set of functions and characters for each key on the keyboard. When you are programming a field that requires alpha numeric entries, the keyboard automatically shifts into the alpha keyboard so that you can simply type the message or descriptor you wish to program. An overlay legend sheet is provided to place on the keyboard while you are programming.

Audaction

Refers to the total of all sales ending in a negative balance.

Auto Scale

Registrations of PLUs with auto scale status will automatically multiply by the weight placed upon a scale connected to the register. Use for items such as produce, that are always sold by weight.

Auto Tare

With auto tare status assigned, a preprogrammed tare weight will automatically subtract from the weight from the scale.

Cancel

Press the CANCEL function to abort a transaction in progress. All current items are removed (voided).

Check Cash

Use the CHECK CASH function to exchange a check for cash outside of a sale.

Check Endorse

If compulsory check endorsement is set with the CHECK key, use the CHECK ENDORSE function to print the endorsement message after a check is inserted into the appropriate printer.

Clerks

Sales *clerks* are individuals who are responsible for selling the merchandise to the customer. Typically, management wants to know merchandise sales levels for each clerk, in order to monitor productivity, account for cash and other media, and/or pay commissions.

Compulsory

When an operation is programmed compulsory, a function (i.e. Non-add number entry) must be performed in order to complete the operation.

Consecutive Number

A count appears at the bottom of each receipt and after each transaction on the journal tape. This count increases by one with each transaction, report, or scan.

Currency Conversion

Use one of the 4 available currency conversion functions to convert and display the value of the transaction in foreign currency. Only cash tender is allowed after pressing a CONV key. Change is calculated and issued in home currency.

Default Program

The original program installed in the *ER-650/650R*. The register has a default program which makes it operational after a RAM clear. Nearly all option, rate, and status programs are set to zero as the default condition.

Destination

Refers to the destination for the sale i.e. eat-in, take out, drive thru.

Discount (Item)

An item discount (coupon or %) subtracts an amount or percentage from the price of an item. This subtraction nets the PLU total.

Discount (Sale)

A sale discount (coupon or %) subtracts an amount or percentage from the entire sale.

Electronic Journal

The electronic journal is an area of memory designated to keep a sales journal. The electronic journal can be printed, if necessary, to provide a traditional record of all register activity.

Error Condition

An error condition signals that mis-operation has occurred. It is identified by an audible tone and an error descriptor appearing on the display.

Error Correct

An error correct operation voids the last item entered, it must be used within a sale.

Food Stamps

In the United States, Food Stamps may be used to purchase eligible food items at food stores that participate in the program. The *ER-650/650R* can assist a retailer in handling food stamp transactions by sorting food stamp and non-food stamp eligible items within each sale and tracking food stamp payments for eligible items.

Gallonage

Gallonage is a status that can be assigned to a department or PLU. Gallonage departments or PLUs accept a price, but print both the price and the quantity of gallons sold. The quantity of gallons is computed from the price per gallon, which is set as the preset price.

Groups

Groups are totals that collect information from designated PLUs. For example all PLU dessert items could collect in a group total called "desserts".

HALO

The high amount lock-out (HALO) limits the amount allowed to be entered in a PLU, or function key.

IRC

Inter Register Communications (IRC) is the term used to describe communications within a network of registers. IRC allows consolidated reporting and down-line programming.

Link PLU

If you wish the registration a PLU to automatically cause the registration of another PLU, enter the number of the PLU you wish to register automatically in the LINK PLU of the PLU.

Macro

Macros record key sequences for later execution. Up to 10 macros may be recorded and executed by pressing a function.

Memory Allocation

Memory allocation is a program that determines how the system memory is divided to provide the correct features for your application. For example, you may require more or less employee memory or PLUs. Memory allocation allows you to maximize the features you need while minimizing the features you do not need.

Modifier

Preceding a PLU entry, a modifier key changes a digit of the PLU number, causing a different PLU to be registered. Modifier keys can be set to change any of the 14 PLU digit positions to any specified digit (0-9).

NLU

Use any of the Number Look Up (NLU) keys to categorize merchandise (as you would with traditional department keys.) NLUs can be programmed to access any PLU number in the register.

No Sale

No sale is an operation to simply open the cash drawer.

Override

Override is an operation used to bypass a programmed price or HALO.

PLUs

Price look-ups (PLUs) are accessed by indexing a code number and pressing the PLU key, or by pressing a PLU key. PLUs can be programmed with a preset or open price. PLUs record their own activity count and dollar total on the PLU report.

Post Tendering

The Post Tendering feature allows the operator to use the register to compute change on cash transactions after the sale has been finalized.

To calculate change due after finalizing the sale, enter the cash amount presented by the customer and then press **CASH**. The amount of change due to the customer is then displayed, and the cash drawer may open.

This is a calculation function only, and no totals or counters are updated by the use of this feature.

Price Level

If memory is allocated for price levels, prices may be assigned at up to five different price levels for each PLU item. Price level keys can then be used to shift the price of a PLU.

Promo

The **PROMO** operation allows items to be sold without cost, i.e. buy two, get one free. **PROMO** activity will remove the item cost from the sale, but the sales count will include the promo item.

Receipt

A receipt is a printed tape given to a customer as a record of the sale transaction.

Register Number

The register number is a programmable number which prints on the receipt and journal tapes. It identifies the electronic cash register the sale or report was performed on.

Stay-Down

When a function is programmed as a Stay-down function, it is valid until changed. For example, a Stay-down clerk remains signed on until either signed off, or another clerk is signed on

Stock PLU

Stock PLUs track the quantity of the PLU item in stock. Each time the PLU is registered, a whole unit subtracts from the stock counter. (Note that if multiplication or decimal multiplication is used when the PLU is registered, the resulting quantity of activity will subtract from the stock counter. Stock is maintained increments to the second decimal position, i.e. "X.XX".)

Surcharge (Item)

An item percent surcharge adds a percentage to the price of an item. This addition nets the PLU total.

Surcharge (Sale)

A sale percent surcharge adds a percentage to the entire sale.

Tare Weight

A tare is the amount of weight accounted for by the container or packaging. By entering a tare weight (as required by law in some areas) the weight of the container is subtracted and only the true weight of the product is measured on the scale.

Tax Exempt

Tax exempt is used to exclude the tax from an entire sale.

Tax Shift

Tax shift keys are used to reverse the tax status of a PLU entry.

Tender

The method of register operation in which payment is made and the transaction is finalized.

Transaction Number

A count appears at the bottom of each receipt and or journal tape. This count increases by one with each transaction, report, or scan.

Void

A void operation will erase a previous item entry. It must be used inside of a sale only.

Waste

The Waste function is used to start and end entries of items that are wasted. Inventory is adjusted.

Index

#

#/NS key 10, 112, 161
programming 162

%

% key 10, 112
operations 45
% Key
programming 163

@

@/For (Prt Screen) key 112
@/For (PRT SCREEN) key 10

A

ADD CHECK key 10
Programming 166
Add-On Tax Rate 135
Age Verification 99, 100, 133
Audaction Total
Print on reports 154
AUTO SCALE PLU 127
AUTO TARE PLU 127

B

baud rate 114

C

Cancel
Operation 51
Cancel key 112
CANCEL key 10
programming 168
Cash

Drawer Limit
CASH (ENTER) key 10
Cash Declaration 87
programming 146
CASH key
programming 169
Cash Sale
Tendering 57
Totaling 56
Cash/Tend (Enter) key 112
Change Limit 223
CHARGE 1-8 key
programming 171
CHARGE 1-8 keys 10
Charge Sale
Tendering 59
Totaling 58
CHECK # key 11
programming 178
Check Cashing 60
CHECK CASHING key 10
programming 173
Check Change Limit 223
CHECK ENDORSEMENT key 11
programming 174
Check File Report 246, 247
CHECK key 11
programming 176
Check Sale
Tendering 57
Totaling 56
Check Tend key 112
Check Tracking Operations 66
Clear All Totals 106
Clear Grand Total 106
Clear PLU File 107
Clear/Esc key 112
CLEAR/ESC key 11
Clearing Memory 103
Clerk # key 112
CLERK # key 11
Clerk In/Out 220
CLERK KEYS 133, 146
Clerk Report 241
Clerk Report descriptors 215, 216
Clerk Time Report 245
Clerks
code entry 23
pop-up 23
printing names 154
programming 158
programming entry method 146
programming staydown/pop up 146
push button 23
sign off instructions 24

- sign on instructions 24
- stay down 23
- time keeping 25
- Clock In/Out 25
- COMPULSORY CONDIMENT PLU 127
- CONDIMENT PLU 127
- Control Lock 14
- Coupon
 - Item/Store 48
 - Sale/Vendor 47
- Credit Card Sale
 - Tendering 59
 - Totaling 58
- Currency Conversion 64
- CURRENCY CONVERSION. 1-4 keys 11
- Currency Symbol
 - setting 155

D

- Date
 - printing 154
- Date Format 147
- Decimal key 10, 112
- Decimal Place 147
- Declaration 87
- Delete PLU 128, 129
- Delete PLU Range 129
- Direct Multiplication
 - Allow? 148
 - more than 1 digit? 148
- DISABLE PROMO 127
- Discount
 - Enter a Percent 46
 - Percent On Sale Total 46
 - Preset Percent 45
- Download Programs 218
- Drawer
 - open drawer alarm 146
 - open during training mode 147
 - setting enforced closed drawer 146
- Drawer Limit 222
- Drive Thru
 - operation 55
- DRIVE THRU
 - operations 76
- DRIVE THRU key 11

E

- Eat In
 - operation 55
- EAT-IN key 11
- electronic journal 156
- Electronic Journal

- activate? 148
- only negative entries 148
- reset 96
- sending reports 148
- stop when full 148
- warning when full 148
- Electronic Journal Operation 91
- Endorsement Message 213
- ENTER key 10
- EPROM Information 107
- ERROR CORRECT key 11
- Error Correction 50
- ESCAPE key 11
- Exempting Tax 43

F

- F/S SHIFT key 11
- F/S SUB key 11
- F/S TEND key 11
- Fast Food Drive Thru
 - operations 76
- Financial Report 235
- Financial Report descriptors 214
- Food Stamp Sales 63
- Foreign Currency Conversion 64
- Front Display screen 15, 21, 22
- Function Key Assignment 110
- Function Key Codes 112
- Function Key Programming 160
- FUNCTION LOOK UP (1-2) key 11
- Function Look-Up Keys
 - Using 27

G

- GALLONAGE ITEM 127
- Grand Total
 - printing on reports 154
 - resetting on reports 146
- Gross Total
 - printing on reports 154
- Group Descriptor Programming 131
- GUEST key 11

H

- Hard Check
 - operations 73
- Hardware Test 105
- Home Currency Symbol
 - setting 154

I

Initial Clear 19
Inventory
 PLU Stock 221
INVENTORY ITEM 127
IRC
 Download Programs 218
IRC Options 113, 229

K

Keyboard Layout 8, 9
keys, register 14
Kitchen Printer
 consolidate items? 156
 print in training? 155
 print in VOID? 155
 priority printing? 156

L

LINK PLU 127
Logo Descriptor 210

M

Machine No. 229
MACRO 1-10 keys 12
Macro setting 226
Manager Control
 negative balances 146
Manager Mode 83
Manager Operation 84
MDSE RETURN key 12
Memory
 Clearing 103
Memory All Clear 103
Memory Allocation 108
Merchandise Return
 operations 49
Miscellaneous Tender Sale
 Tendering 59
 Totaling 58
Modifier
 staydown or pop-up 147
MODIFIER 1-5 keys 12
MODIFIER Key
 operation 38
Modifier/Size 191
Multiplication
 operation 30
Multiplication With Decimal Point 31

N

NLU 10
NLU Code Number 217
No Sale
 Operations 52
Non Add Number
 Operation 52
NON-ADD # COMP 126
Numeric Keypad 10

O

Open Drawer 52
Open PLU
 operation 28
 Operation 34
Programming 126

P

Page Down key 112
PAGE DOWN key 12
Page Up key 112
PAGE UP key 12
Paid Out
 Operations 54
PAID OUT 1-3 key
 programming 193
PAID OUT 1-3 keys 12
Paper
 installing 3
Paper Feed Key 112
PAPER FEED Key 12
Paper Sensor
 active? 147
parity 114
PBAL key 12
 programming 192
PC Communication 96
PC Schedule Time 230
PLU
 DISABLE 127
PLU key 12
PLU Lookup keys 97
PLU Multiplication 35
PLU Multiplication With Decimal Point 36
PLU Options - Reference Information 126
PLU Price Inquiry 37
PLU Repeat Entry
 Operation 29
PLU Report 240
PLU Stock 221
Post Tender 62
Programming 146

- Postamble 212
- Posting Balances Manually 68
- Preamble 211
- Preset Price PLU
 - Operation 28, 34
 - Programming 126
- preset tender keys 12, 226
- price embedded bar codes 149
- PRICE INQUIRY key 12
- Price Level
 - staydown or pop-up? 148
- PRICE LEVEL Key
 - operation 39
- Price Level Keys
 - disable 148
- PRICE LEVEL keys 12
- Print
 - % Sales on PLU report? 154
 - consecutive number? 154
 - grand total? 155
 - gross total? 155
 - KP order on receipt? 155
 - Machine No.? 154
 - media on clerk report? 154
 - Preamble/postamble? 156
 - price on KP? 155
 - SBTL w/o tax? 155
 - sign on/off? 155
 - tax symbol? 154
 - VAT options 155
 - Void & Return on report? 154
 - Z counter? 154
- PRINT CHECK key
 - programming 194
- PRINT CHECK keys 12
- Print Format 88
- Print Option Programming 150
- Print Screen
 - disable 147
- PRINT SCREEN key 10
- Priority printing on KP? 156
- Program Mode Menu 121
- Program Overlay 8, 9
- Program Scans 232
- PROMO key 12
 - operation 40
 - programming 195

R

- Rear Display 18
 - Messages 18
- RECD ON ACCT 1-3 key
 - programming 196
- RECD ON ACCT keys 12

- Receipt
 - allow multiple receipts 146
 - on Request 65
 - On/Off 65
- Received On Account
 - Operations 53
- Register Print Format 88
- Register Printing
 - stop 89
- Report Sample
 - Financial Report 235
- Report Samples
 - All Clerk Report 241
 - Check File Report 246, 247
 - Clerk Time Report 245
 - Individual Clerk 242
 - PLU Report 240
 - Stock Report 244
 - Time Report 239
- Reset Electronic Journal 96
- Reset Report Mode 93
- RESET Z COUNTER 147
- Return Merchandise
 - Operation 49
- Rounding Up/Down 147
- RS232C Port 1/RS232C Port 2 Options 114

S

- SBTL key 12
- SCALE key 13
- Scale Operations 78
 - Manual Weight Entry 82
 - Tare Entry 80, 81
- SCALEABLE PLU 127
- SERVICE key 13
 - programming 199
- Shifting Tax 42
- Single Item PLU
 - Operation 33
 - programming 126
- Size/Modifier 191
- Soft Check
 - operations 70
- Split Pricing
 - Operation 32
- Split Pricing PLU
 - Operation 36
- Split Tender 61
- Stock Report 244
- Stop Register Printing 89
- Subtotal
 - print when pressed 154
- Subtotaling a Sale 55
- System Option Programming 142

T

TABLE key 13
 programming 201
Take Out
 operation 55
TAKE OUT key 11
TARE key 13
Tare Weight 225
Tare Weight Entry 80, 81
Tax
 printing tax amount 155
 printing taxable totals 155
 programming a tax table 136
 programming a VAT 140, 141
TAX EXEMPT key 13
 programming 202, 203
Tax Programming 134
Tax Shift key 112
TAX SHIFT key 13
Tender
 Post 62
 Split 61
Test
 Display 105
 Hardware 105
 Keyboard 105
 Mode 105
 Printer 105
 Printing Pattern 105
 RS232 105
Time
 printing 154
Time & Date setting 224
Time In/Out 25
TIME IN/OUT key 13
 programming 204
Time Report 239
TIP key 13
 programming 205
Training Mode 90
 printing "TRAIN MODE" 155
Training Mode Password 231
Transaction #
 resetting on reports 146

U

Unpacking 2
UPC number 27

V

VALIDATE key
 programming 207

VALIDATION key 13
VAT printing options 155
Void
 Last Item 50
 Previous Item 50
Void Item key 112
VOID ITEM key 13
 programming 208
Void Position
 operations 51

W

WASTE key 13
 operation 41
 programming 209
weight embedded bar codes 149

X

X Reports 85

Y

Yes/No key 112
YES/NO key 13

Z

Z Reports 94
Zero Skip on reports 154

JK68-60947E