

QTP/QSP PRICE COMPUTING SCALES

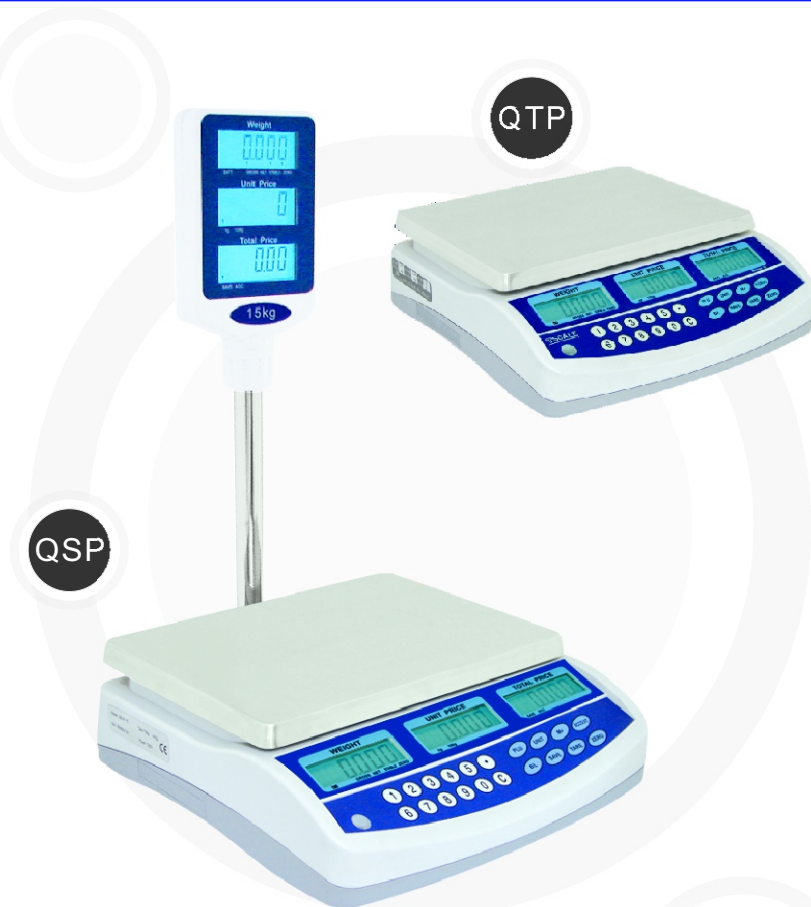

FEATURES

- Capacities from 6kg to 30 kg
- 20 key embossed membrane keyboard
Function include units conversion,
- 10 sets PLU, accumulation, give change
- Standard stainless steel pan and dust cover
- OIML approve/ EC type approve / model selectable(T7305)
- External resolution 1/3000(approved) /1/6000 or dual range(max)

OPTIONS

RS-232 can connect to a printer or ECR

DIMENSION (mm)

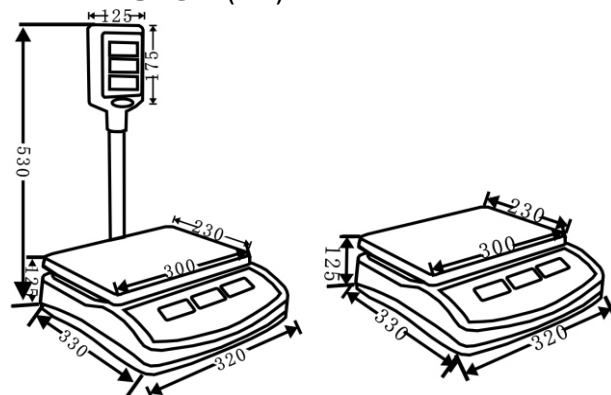

SPECIFICATIONS

Model	QTP	QSP
Display	Front and rear: 20mm LCD display, with backlight	Front and pole: 20mm LCD display, with backlight
Capacity	6kg / 15kg / 30kg	
Housing	ABS	
Max. Divisions	3,000e (OIML/EC type approval) or 6,000e or dual range	
Keypad	20 keys	
Pan size	230×300mm SST pan	
Operate temp	0°C~+40°C	
ADC	sigma delta	
ADC update	≤1/10 second	
Power	AC adapter (9V/800mA) / Built in rechargeable battery (6V/4Ah)	
Gross weight	5.1kg	6kg
Packing	Master carton (4 in 1) Gross weight 22.85kg, dimension 0.185m ³ , 40' container can load 1200 units, 20' container can load 600 units	Master carton (4 in 1) Gross weight 26.5kg, dimension 0.26m ³ , 40' container can load 860 units, 20' container can load 430 units