

# SHARP SERVICE MANUAL

CODE: 00ZMX3610/S5E

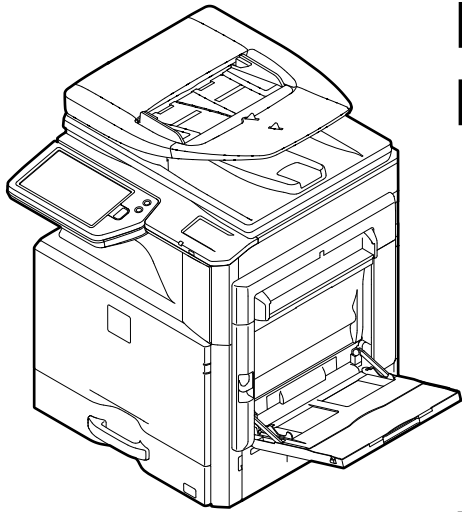

## DIGITAL FULL COLOR MULTIFUNCTIONAL SYSTEM

**MX-1810U/2010U**

**MX-2310U/3111U**

**MX-2610N/3110N**

**MODEL MX-3610N**

### CONTENTS

#### NOTE FOR SERVICING

[1] PRODUCT OUTLINE .....	1-1
[2] CONSUMABLE PARTS .....	2-1
[3] EXTERNAL VIEW AND INTERNAL STRUCTURE .....	3-1
[4] ADJUSTMENTS AND SETTINGS .....	4-1
[5] SIMULATION .....	5-1
[6] TROUBLESHOOTING .....	6-1
[7] FIRMWARE UPDATE .....	7-1
[8] MAINTENANCE .....	8-1
[9] DISASSEMBLY AND ASSEMBLY .....	9-1
[10] VARIOUS STORAGE DATA HANDLING .....	10-1
[11] SERVICE WEB PAGE .....	11-1
[12] OPERATIONAL DESCRIPTIONS .....	12-1
[13] ELECTRICAL SECTION .....	13-1
[14] SPECIFICATIONS .....	14-1
[15] TOOL LIST .....	15-1

Parts marked with "▲" are important for maintaining the safety of the set. Be sure to replace these parts with specified ones for maintaining the safety and performance of the set.

# CONTENTS

## NOTE FOR SERVICING

1. Precautions for servicing . . . . . i
2. Warning for servicing . . . . . i
3. Note for installing site . . . . . i
4. Note for handling PWB and electronic parts . . . . . ii
5. Note for repairing/replacing the LSU . . . . . iii
6. Note for handling the drum unit, the transfer unit, the developing unit . . . . . iii
7. Screw tightening torque . . . . . iii

## [1] PRODUCT OUTLINE

1. System diagram . . . . . 1-1
2. Option list . . . . . 1-5

## [2] CONSUMABLE PARTS

1. Supply system table . . . . . 2-1
2. Maintenance parts list . . . . . 2-7
3. Definition of developer/drum life end . . . . . 2-19
4. Production number identification . . . . . 2-21
5. Environmental conditions . . . . . 2-21

## [3] EXTERNAL VIEW AND INTERNAL STRUCTURE

1. External view . . . . . 3-1
2. Internal structure . . . . . 3-4
3. I/F connectors . . . . . 3-5
4. Operation panel . . . . . 3-6
5. Sensors and detectors . . . . . 3-8
6. Switches . . . . . 3-13
7. Clutches and solenoids . . . . . 3-15
8. Motors . . . . . 3-18
9. Rollers . . . . . 3-21
10. Lamps . . . . . 3-26
11. Fans and filter . . . . . 3-29
12. Gates . . . . . 3-31
13. Heater . . . . . 3-33
14. PWB/Memory device . . . . . 3-34
15. Fuses and Thermostats . . . . . 3-40
16. Lock . . . . . 3-43

## [4] ADJUSTMENTS AND SETTINGS

1. General . . . . . 4-1
2. Adjustment item list . . . . . 4-1
3. Details of adjustment . . . . . 4-3

## [5] SIMULATION

1. General and purpose . . . . . 5-1
2. Starting the simulation . . . . . 5-1
3. List of simulation codes . . . . . 5-4
4. Details of simulation . . . . . 5-10

## [6] TROUBLESHOOTING

1. Error code and troubleshooting . . . . . 6-1
2. JAM and troubleshooting . . . . . 6-38
3. Image send communication report code . . . . . 6-49
4. Dial tone . . . . . 6-53

## [7] FIRMWARE UPDATE

1. Outline . . . . . 7-1
2. Update procedure . . . . . 7-1

## [8] MAINTENANCE

1. Works necessary when executing the maintenance . . . . . 8-1
2. Display of maintenance execution timing . . . . . 8-2
3. Maintenance list . . . . . 8-4

## [9] DISASSEMBLY AND ASSEMBLY

1. Disassembly of Units . . . . . 9-1
2. Disassembly and assembly of each unit . . . . . 9-24

## [10] VARIOUS STORAGE DATA HANDLING

1. HDD/SD card memory map . . . . . 10-1
2. Necessary steps when replacing the PWB, HDD and the SD Card . . . . . 10-6
3. HDD/SD card SIM format operation . . . . . 10-12
4. Necessary works and notes for replacement of the mirroring kit HDD . . . . . 10-14
5. Note for installing and repairing the mirroring kit . . . . . 10-17

## [11] SERVICE WEB PAGE

1. General . . . . . 11-1
2. Details and operation procedures . . . . . 11-1

## [12] OPERATIONAL DESCRIPTIONS

1. Operation panel section . . . . . 12-1
2. Scanner section . . . . . 12-6
3. Manual paper feed section . . . . . 12-8
4. Tray paper feed section . . . . . 12-13
5. Paper registration section (Paper transport section) . . . . . 12-19
6. Paper exit section . . . . . 12-23
7. ADU section . . . . . 12-29
8. LSU section . . . . . 12-34
9. Process section . . . . . 12-41
10. Fusing section . . . . . 12-79
11. RSPF section . . . . . 12-90
12. Fan and filter . . . . . 12-96
13. Operations and specifications of counters . . . . . 12-97

## [13] ELECTRICAL SECTION

1. Block diagram . . . . . 13-1
2. Power line diagram . . . . . 13-26
3. Actual wiring chart . . . . . 13-32
4. Signal list . . . . . 13-68

## [14] SPECIFICATIONS

1. 18cpm/20cpm machine . . . . . 14-1
2. 23cpm/31cpm(G) machine . . . . . 14-10
3. 26cpm/36cpm/31cpm(A) machine . . . . . 14-19
4. List of parts included in the package of developer . . . . . 14-30













## [15] TOOL LIST . . . . . 15-1







# Symbols in this manual

The lists of symbols used in this manual are shown below.









The meaning of each symbol described in the table must be understood for proper servicing.

















## 1. Symbols used for notes and cautions





Symbol	Meaning	
 CAUTION	CAUTION	Indicates a general caution item.
 CAUTION HIGH TEMPERATURE	HIGH TEMP	Be careful of a high temperature in the fusing section.
 CAUTION HIGH VOLTAGE	HIGH VOLTAGE	Be careful of an electric shock where a high voltage is applied such as the high voltage PWB, the main charger, and the process section.
 DANGER	DANGER	Indicates danger.
	HANDLE WITH CARE	Indicates a part which requires special care for handling such as the HDD, and the LSU.
	INHIBIT	Indicates inhibit.
	NO ELECTROSTATIC CHARGE	Be careful to keep away from static electricity. (PWB's and electric parts)
	NO DUST, FINGER PRINT, DIRT, SCRATCH	Be careful not to touch directly, such as the optical section, the photoconductor, and the DV roller. Also be careful not to scratch.
	NO SCRATCH	
	NO LIGHT	Be careful not to expose to light, such as the photoconductor, and the test chart.
	NO SOLVENT	Be careful not to use a solvent in cleaning, etc.
	NO DISASSEMBLE	Do not disassemble. Not serviceable. Example CCD unit.

Symbol	Meaning	
	OK/GOOD	Indicates a correct procedure or result in an adjustment, etc.
	NO GOOD	Indicates a wrong procedure or result in an adjustment, etc.
	NOTE	Indicates a note.
	IMPORTANT	Indicates an important item.
	REFER	Indicates a reference page, etc.
	NEW	Indicates a new technology, a new method, or a new item.
	EXAMPLE	Indicates a description using an example.





## 2. Symbols used in the work contents

Symbol	Meaning (Work content)	
	Adhesion	Indicates that a seal, etc. is attached.
	Adjustment	Indicates an adjustment.
	Measure a dimension or a size.	Indicates that a dimension or a length is measured.
	Apply grease	Indicates that grease is to be applied.
	Apply conductive grease	Indicates conductive grease is applied
	Cleaning (Dry)	Indicates clean with a dry cloth.
	Cleaning (Wet)	Indicates clean with a cloth dampened with water.
	Cleaning (Alcohol)	Indicates clean with alcohol.
	Cleaning (Blower)	Indicates cleaning is done with a blower/brush.





Symbol	Meaning (Work content)	
	Cleaning (Vacuum)	Indicates that cleaning is performed with a vacuum cleaner.
	Cleaning (Brush)	Indicates that cleaning is performed with a brush.
	Oil	Indicates that oil is applied to lubricate.
	Apply powder.	Indicates that setting power is applied to the photoconductor drum, the transfer belt, etc.
	Replace	Indicates that a part is replaced.
	Check	Indicates that a check (replacement, adjustment, cleaning) is performed.
	Cut	Indicates that cutting is performed.
	Loosen	Indicates that a screw is loosened.
	Connect	Indicates that a connector is connected.
	Disconnect	Indicates that a connector is disconnected.
	Remove a harness.	Indicates that a harness is unsecured.
	Attach a harness.	Indicates that a harness is secured.
	Remove a clamp.	
	Attach a clamp.	
	Release a hook.	Indicates that a hook is released.
	Fix a hook.	Indicates that a hook is fixed.
	Disengage the pawl.	

Symbol	Meaning (Work content)	
	Engage the pawl.	
	Screw lock	Indicates that a screw is secured with adhesive.
	Unlock	
	Turn OFF the power.	
	Disconnect the power plug.	

### 3. Symbols used for kinds of parts

Symbol	Meaning (Kinds of parts)	
	Maintenance part	Indicates a part which is replaced in a maintenance procedure.
	Consumable part	Indicates a consumable part such as a photoconductor, developer, a transfer belt, etc.
	Waste part	Indicates a waste part which is consumed but excluded from the above consumable parts. (A roller, a seal, etc.)
	Unit part	Indicates a part which is designated as a unit.
	Included part	Indicates a part which is included in the package

### 4. Symbols used for additional descriptions

Symbol	Meaning	
	View from the top	Indicates from which angle the drawing is viewed.
	View from the bottom	
	View from the front	
	View from the back	

# NOTE FOR SERVICING

## 1. Precautions for servicing

- When servicing, disconnect the power plug, the printer cable, the network cable, and the telephone line from the machine, except when performing the communication test, etc.  
It may cause an injury or an electric shock.
- There is a high temperature area inside the machine. Use extreme care when servicing.  
It may cause a burn.
- There is a high voltage section inside the machine which may cause an electric shock. Be careful when servicing.
- Do not disassemble the laser unit. Do not insert a reflective material such as a screwdriver in the laser beam path.  
It may damage eyes by reflection of laser beams.
- When servicing with the machine operating, be careful not to squeeze your hands by the chain, the belt, the gear, and other driving sections.
- Do not leave the machine with the cabinet disassembled.  
Do not allow any person other than a serviceman to touch inside the machine. It may cause an electric shock, a burn, or an injury.
- When servicing, do not breathe toner, developer, and ink excessively. Do not get them in the eyes.  
If toner, developer, or ink enters your eyes, wash it away with water immediately, and consult a doctor if necessary.
- The machine has got sharp edges inside. Be careful not to damage fingers when servicing.
- Do not throw toner or a toner cartridge in a fire. Otherwise, toner may ignite and burn you.
- When replacing a lithium battery on a PWB, only use the specified replacement battery.  
If a battery of different specification is used, it may cause a machine malfunction or breakdown.
- When carrying a unit with PWB or electronic parts installed to it, be sure to put it in an anti-static-electricity bag.  
It may otherwise cause a machine breakdown or malfunction.

CAUTION  
DOUBLE POLE/NEUTRAL FUSING  
(200V series only)

## 2. Warning for servicing

- Be sure to connect the power cord only to a power outlet that meets the specified voltage and current requirements.  
Avoid complex wiring, which may lead to a fire or an electric shock.  
It may cause a fire or an electric shock.
- If there is any abnormality such as a smoke or an abnormal smell, interrupt the job and disconnect the power plug.  
It may cause a fire or an electric shock.
- Be sure to connect the grounding wire. If an electric leakage occurs without grounding, a fire or an electric shock may result.  
To protect the machine and the power unit from lightning, grounding must be made.
- When connecting the grounding wire, never connect it to the following points.
  - Gas tube
  - Lightning conductor
  - A water pipe or a water faucet, which is not recognized as a grounding object by the authorities.
  - Grounding wire for telephone lineIt may cause an explosion, a fire or an electric shock.

- Do not damage, break, or stress the power cord.  
Do not put heavy objects on the power cable. Do not stress, forcibly bend, or pull the power cord.  
It may cause a fire or an electric shock.
- Keep the power cable away from a heat source.  
Do not insert the power plug with dust on it into a power outlet.  
It may cause a fire or an electric shock.
- Do not place liquids or foreign metallic objects inside the machine.  
It may cause a fire or an electric shock.
- Do not touch the power cord, insert the phone jack, operate the machine, or perform service on the machine with wet or oily hands.  
It may cause an electric shock.

## 3. Note for installing site

Do not install the machine at the following sites.

- **Place of high temperature, high humidity, low temperature, low humidity, place under an extreme change in temperature and humidity.**  
Paper may get damp and form condensation inside the machine, causing paper jam or copy dirt.  
For operating and storing conditions, refer to the specifications described later.

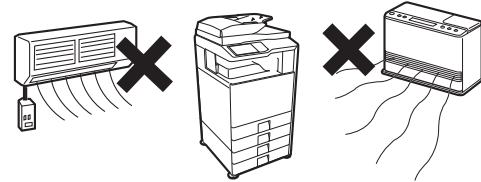

- **Place of extreme vibrations**  
It may cause a breakdown.

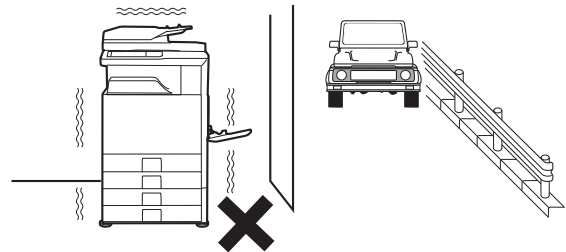

- **Poorly ventilated place**  
An electrostatic type copier will produce ozone.  
The quantity of ozone produced is designed to a low level so as not to affect human bodies. However, continuous use of such a machine may produce an ozone smell. Install the machine in a well ventilated place.

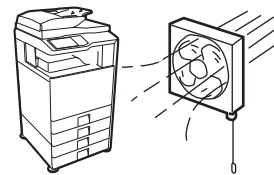

- **Place of direct sunlight.**

Plastic parts and ink may be deformed, discolored, or may undergo qualitative change.

It may cause a breakdown or output quality problems.

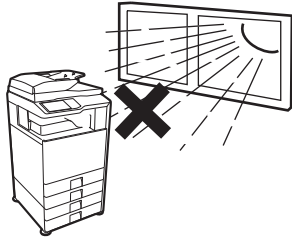

- **Place which is full of organic gases such as ammonium**

The organic photo-conductor (OPC) drum used in the machine may undergo qualitative change due to organic gases such as ammonium.

Installation of this machine near a diazo-type copier and blue print machine may result in poor quality output.



- **Place of much dust**

When dust or contaminants enters the machine, it may cause a breakdown or poor quality output.



- **Place near a wall**

The machine will require ventilation.

If ventilation is not proper, poor output or machine failure may result.

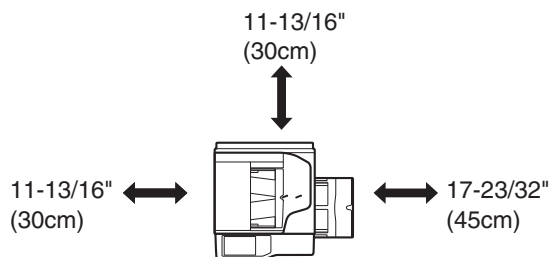

- **Unstable or irregular surface**

If the machine is dropped or tips over, it may cause injury or machine malfunction.

Use an optional desk or an exclusive-use desk.

When using the optional desk, be sure to fix the adjuster and lock the casters.

#### 4. Note for handling PWB and electronic parts

When handling the PWB and the electronic parts, be sure to observe the following precautions in order to prevent against damage by static electricity.

- When in transit or storing, put the parts in an anti-static bag or an anti-static case and do not touch them with bare hands.

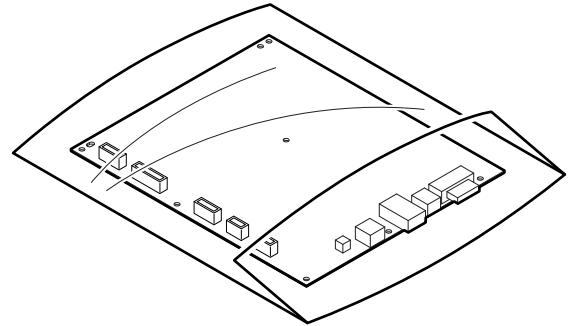

- When and after removing the parts from an anti-static bag (case), use an earth band as shown below:
- Put an earth band to your arm, and connect it to the machine.



- When repairing or replacing an electronic part, perform the procedure on an anti-static mat.

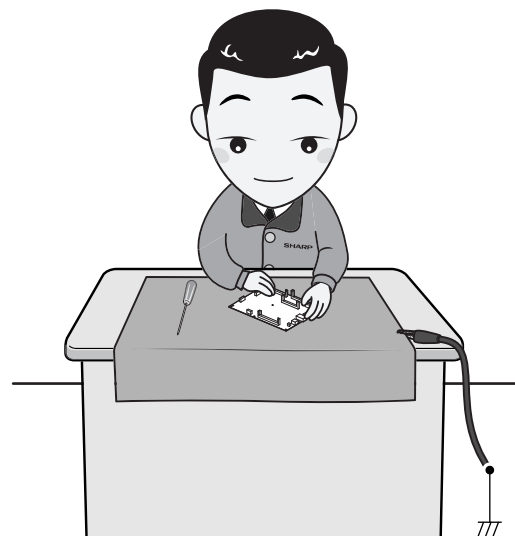

## 5. Note for repairing/replacing the LSU

When repairing or replacing, be sure to observe the following items.

- When repairing or replacing the LSU, be sure to disconnect the power plug from the power outlet.
- When repairing or replacing the LSU, follow the procedures described in this Service Manual.
- When checking the operations after repairing the LSU, keep all the parts including the cover installed and perform the operation check.
- Do not modify the LSU.
- When visually checking the inside of the machine for the operation check, be careful not to allow laser beams to enter the eyes.

If the above precaution is neglected or the LSU is modified, ones safety may be at risk.

## 6. Note for handling the drum unit, the transfer unit, the developing unit

When handling the OPC drum unit, the transfer unit, and the developing unit, strictly observe the following items.

If these items are neglected, a trouble may be generated in the copy and print image quality.

### Drum unit

- Avoid working at a place with strong lights.
- Do not expose the OPC drum to lights including interior lights for a long time.
- When the OPC drum is removed from the machine, cover it with light blocking material. (When using paper, use about 10 sheets of paper to cover it.)
- Be careful not to attach fingerprints, oil, grease, or other foreign material on the OPC drum surface.

### Transfer unit

- Be careful not to leave fingerprints, oil, grease, or other foreign material on the transfer roller, primary transfer belt, and the secondary transfer belt.

### Developing unit

- Be careful not to leave fingerprints, oil, grease, or other foreign material on the developing unit.

## 7. Screw tightening torque

The screws used in this machine are largely classified into three types.

These types are classified according to the shape of the screw grooves and use positions.

The table below shows the types of the screws and the tightening torques depending on the use position.

When tightening the screws for repair or maintenance, refer to the table.

However, for the other conditions of tightening screws than specified on this table, or under special circumstances, the details are described on the separate page. Refer to the descriptions on such an exception.

**Important**

Especially for the screw fixing positions where there is an electrode or a current flows, use enough care to tighten securely to avoid loosening.

## Screw kinds and tightening torques

Normal screws, set screws (including step screws)

Screw diameter	Material to be fixed	Tightening torque (N·m)	Tightening torque (kgf·cm)	Tightening torque (lbft)
M2.6	Steel plate	0.8 - 1.0	8 - 10	0.6 - 0.7
M3	Steel plate	1.0 - 1.2	10 - 12	0.7 - 0.9
M4	Steel plate	1.6 - 1.8	16 - 18	1.2 - 1.3

Tapping screws (for iron)

Screw diameter	Material to be fixed	Tightening torque (N·m)	Tightening torque (kgf·cm)	Tightening torque (lbft)
M3	Steel plate (Plate thickness 0.8mm or above)	1.0 - 1.2	10 - 12	0.7 - 0.9
M4	Steel plate (Plate thickness 0.8mm or above)	1.6 - 1.8	16 - 18	1.2 - 1.3
M3	Steel plate (Plate thickness less than 0.8mm)	0.6 - 0.8	6 - 8	0.4 - 0.6
M4	Steel plate (Plate thickness less than 0.8mm)	1.2 - 1.4	12 - 14	0.9 - 1.0

Tapping screw (for plastic)

Screw diameter	Material to be fixed	Tightening torque (N·m)	Tightening torque (kgf·cm)	Tightening torque (lbft)
M3	Plastic resin	0.6 - 0.8	6 - 8	0.4 - 0.6
M4	Plastic resin	1.0 - 1.2	10 - 12	0.7 - 0.9









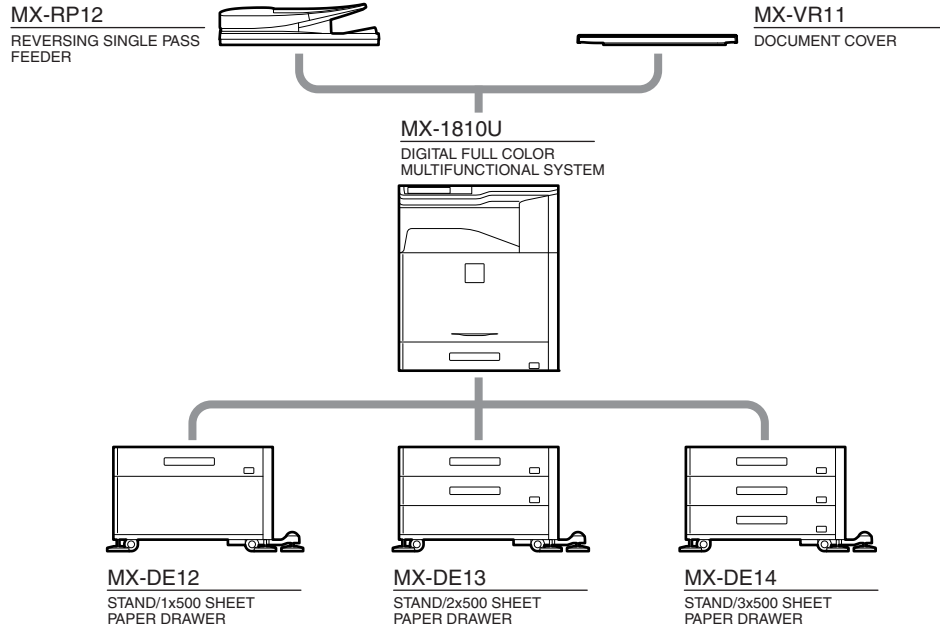

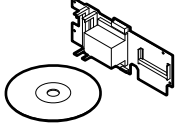

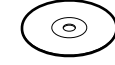

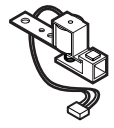
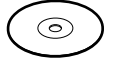
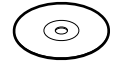
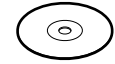
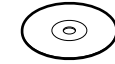
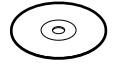
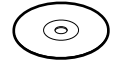
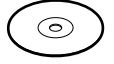
Name in the manual	Model name
18cpm machine	MX-1810U
20cpm machine	MX-2010U
23cpm machine	MX-2310U
26cpm machine	MX-2610N
31cpm(G) machine	MX-3111U
31cpm(A) machine	MX-3110N
31cpm machine	MX-3111U/MX-3110N
36cpm machine	MX-3610N

# [1] PRODUCT OUTLINE

## 1. System diagram

### A. 18cpm machine

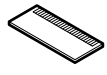

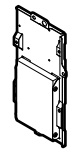
<p>MX-PB14 PRINTER EXPANSION KIT</p> 	<p>MX-PK11 PS3 EXPANSION KIT</p> 	<p>MX-PUX1 XPS EXPANSION KIT</p> 	<p>MX-PF10 BARCODE FONT KIT</p> 	<p>MX-FX11 FACSIMILE EXPANSION KIT</p> 	<p>AR-SU1 STAMP UNIT</p> 
<p>MX-FWX1 INTERNET FAX EXPANSION KIT</p> 	<p>MX-USX1 SHARPPDESK 1 LICENSE KIT</p> 	<p>MX-USX5 SHARPPDESK 5 LICENSE KIT</p> 	<p>MX-US10 SHARPPDESK 10 LICENSE KIT</p> 	<p>MX-US50 SHARPPDESK 50 LICENSE KIT</p> 	<p>MX-USA0 SHARPPDESK 100 LICENSE KIT</p> 
<p>MX-AMX1 APPLICATION INTEGRATION MODULE</p> 	<p>MX-AMX2 APPLICATION COMMUNICATION MODULE</p> 	<p>MX-AMX3 EXTERNAL ACCOUNT MODULE</p> 	<p>MX-UN01A Sharp OSA Network Scanner Tool 1 License Kit</p> 	<p>MX-UN05A Sharp OSA Network Scanner Tool 5 License Kit</p> 	<p>MX-UN10A Sharp OSA Network Scanner Tool 10 License Kit</p> 
<p>MX-UN50A Sharp OSA Network Scanner Tool 50 License Kit</p> 	<p>MX-UN1HA Sharp OSA Network Scanner Tool 100 License Kit</p> 	<p>MX-SM10 EXPANSION MEMORY BOARD</p> 	<p>AR-SV1 STAMP CARTRIDGE</p> 	<p>MX-HD11 HARD DISK EXPANSION KIT</p> 	



## B. 20cpm machine

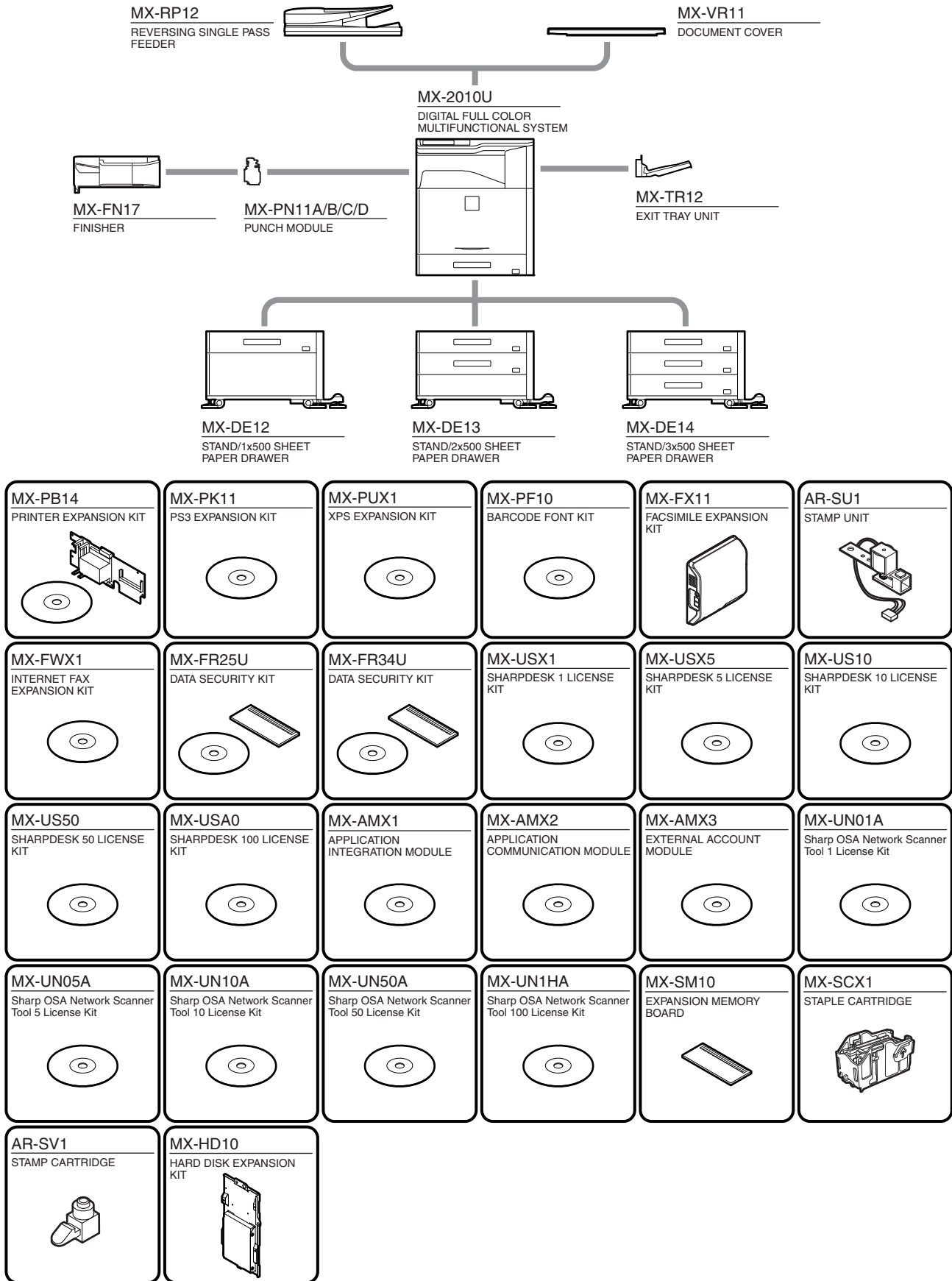

**C. 23cpm/31cpm(G) machine**

MX-2310U  
MX-3111U  
DIGITAL FULL COLOR  
MULTIFUNCTIONAL SYSTEM

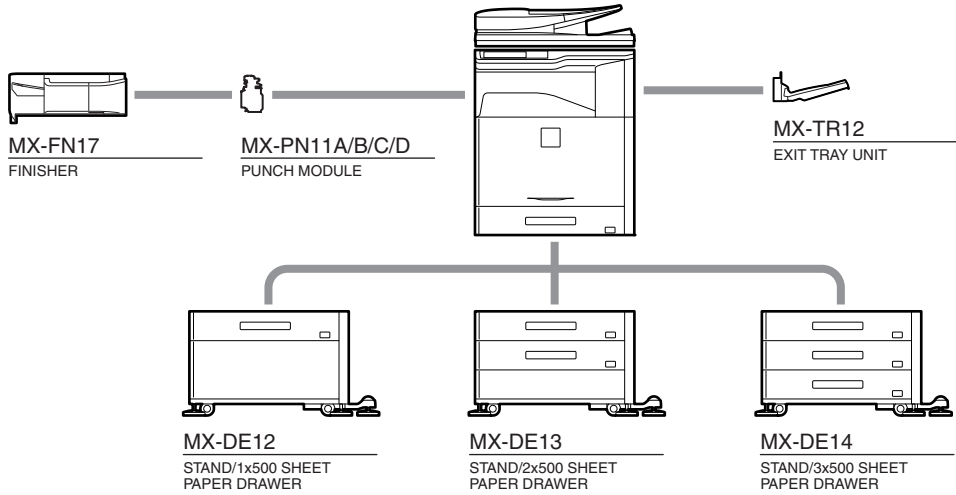

<p>MX-PB14 PRINTER EXPANSION KIT</p>	<p>MX-PK11 PS3 EXPANSION KIT</p>	<p>MX-PUX1 XPS EXPANSION KIT</p>	<p>MX-PF10 BARCODE FONT KIT</p>	<p>MX-FX11 FACSIMILE EXPANSION KIT</p>	<p>AR-SU1 STAMP UNIT</p>
<p>MX-FWX1 INTERNET FAX EXPANSION KIT</p>	<p>MX-FR25U DATA SECURITY KIT</p>	<p>MX-FR34U DATA SECURITY KIT</p>	<p>MX-USX1 SHARPDESK 1 LICENSE KIT</p>	<p>MX-USX5 SHARPDESK 5 LICENSE KIT</p>	<p>MX-US10 SHARPDESK 10 LICENSE KIT</p>
<p>MX-US50 SHARPDESK 50 LICENSE KIT</p>	<p>MX-USA0 SHARPDESK 100 LICENSE KIT</p>	<p>MX-AMX1 APPLICATION INTEGRATION MODULE</p>	<p>MX-AMX2 APPLICATION COMMUNICATION MODULE</p>	<p>MX-AMX3 EXTERNAL ACCOUNT MODULE</p>	<p>MX-UN01A Sharp OSA Network Scanner Tool 1 License Kit</p>
<p>MX-UN05A Sharp OSA Network Scanner Tool 5 License Kit</p>	<p>MX-UN10A Sharp OSA Network Scanner Tool 10 License Kit</p>	<p>MX-UN50A Sharp OSA Network Scanner Tool 50 License Kit</p>	<p>MX-UN1HA Sharp OSA Network Scanner Tool 100 License Kit</p>	<p>MX-SM10 EXPANSION MEMORY BOARD</p>	<p>MX-SCX1 STAPLE CARTRIDGE</p>
<p>AR-SV1 STAMP CARTRIDGE</p>					

## D. 26cpm/36cpm/31cpm(A) machine

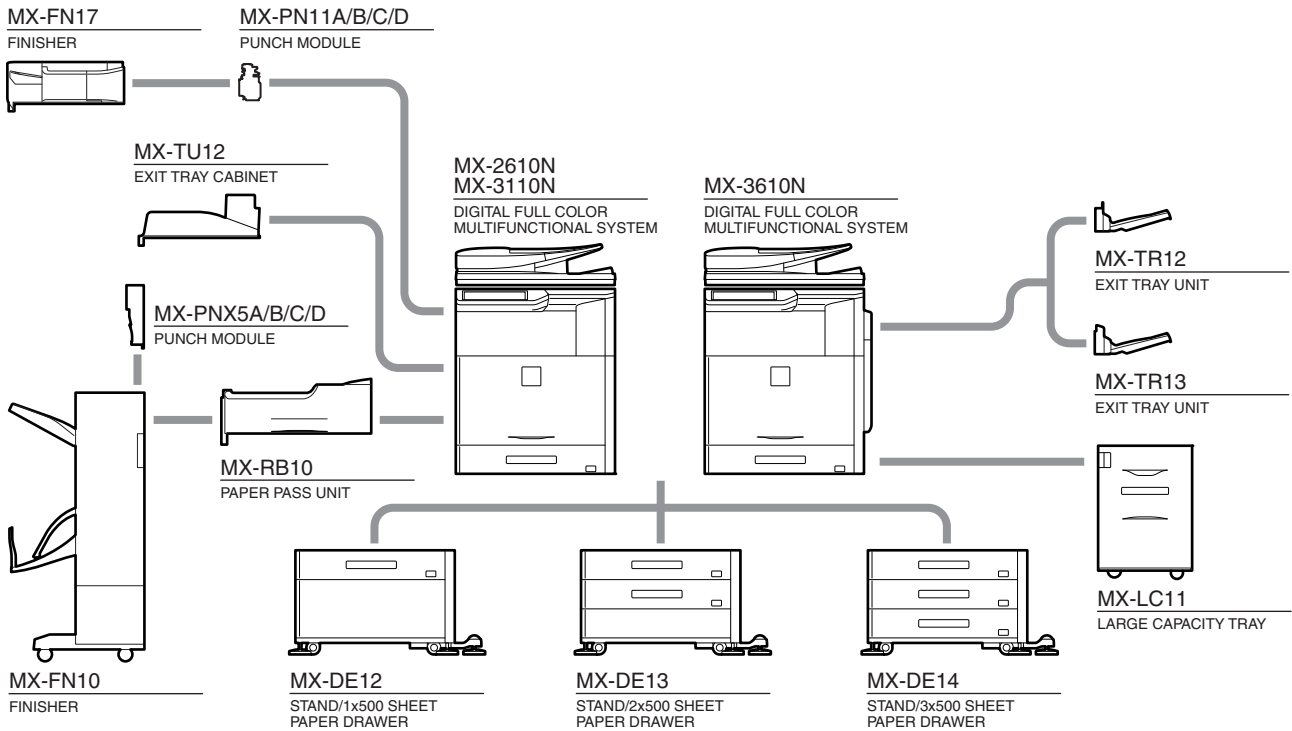

<b>MX-PK11</b> PS3 EXPANSION KIT 	<b>MX-PUX1</b> XPS EXPANSION KIT 	<b>MX-PF10</b> BARCODE FONT KIT 	<b>MX-FX11</b> FACSIMILE EXPANSION KIT 	<b>AR-SU1</b> STAMP UNIT 	<b>MX-FWX1</b> INTERNET FAX EXPANSION KIT 
<b>MX-EB11</b> ENHANCED COMPRESSION KIT 	<b>MX-FR30U</b> DATA SECURITY KIT 	<b>MX-EB12</b> MIRRORING KIT 	<b>MX-USX1</b> SHARPDESK 1 LICENSE KIT 	<b>MX-USX5</b> SHARPDESK 5 LICENSE KIT 	<b>MX-US10</b> SHARPDESK 10 LICENSE KIT 
<b>MX-US50</b> SHARPDESK 50 LICENSE KIT 	<b>MX-USA0</b> SHARPDESK 100 LICENSE KIT 	<b>MX-AMX1</b> APPLICATION INTEGRATION MODULE 	<b>MX-AMX2</b> APPLICATION COMMUNICATION MODULE 	<b>MX-AMX3</b> EXTERNAL ACCOUNT MODULE 	<b>MX-UN01A</b> Sharp OSA Network Scanner Tool 1 License Kit 
<b>MX-UN05A</b> Sharp OSA Network Scanner Tool 5 License Kit 	<b>MX-UN10A</b> Sharp OSA Network Scanner Tool 10 License Kit 	<b>MX-UN50A</b> Sharp OSA Network Scanner Tool 50 License Kit 	<b>MX-UN1HA</b> Sharp OSA Network Scanner Tool 100 License Kit 	<b>MX-KB11</b> KEYBOARD 	<b>MX-AM10</b> WEB BROWSING EXPANSION KIT 
<b>MX-SM10</b> EXPANSION MEMORY BOARD 	<b>MX-SCX1</b> STAPLE CARTRIDGE 	<b>AR-SC3</b> STAPLE CARTRIDGE 	<b>AR-SV1</b> STAMP CARTRIDGE 		

## 2. Option list

	Model name	Name	MX-1810U	MX-2010U	MX-2310U	MX-3111U	MX-2610N	MX-3110N	MX-3610N	Remarks
Document feed system	MX-RP12	REVERSING SINGLE PASS FEEDER	OPT	OPT	STD	STD	STD	STD	STD	
	MX-VR11	DOCUMENT COVER	OPT	OPT	---	---	---	---	---	
Paper feed system	MX-DE12	STAND/1x500 SHEET PAPER DRAWER	OPT	OPT	OPT	OPT	OPT	OPT	OPT	
	MX-DE13	STAND/2x500 SHEET PAPER DRAWER	OPT	OPT	OPT	OPT	OPT	OPT	OPT	
	MX-DE14	STAND/3x500 SHEET PAPER DRAWER	OPT	OPT	OPT	OPT	OPT	OPT	OPT	
	MX-LC11	LARGE CAPACITY TRAY	---	---	---	---	OPT	OPT	OPT	
Paper exit system	MX-TR12	EXIT TRAY UNIT	---	OPT	OPT	OPT	OPT	OPT	---	
	MX-TR13	EXIT TRAY UNIT	---	---	---	---	---	---	OPT	
	MX-TU12	EXIT TRAY CABINET	---	STD	STD	STD	STD/ OPT	STD/ OPT	STD/ OPT	*6
	MX-FN17	FINISHER	---	OPT	OPT	OPT	OPT	OPT	OPT	
	MX-PN11A	PUNCH MODULE	---	OPT	OPT	OPT	OPT	OPT	OPT	
	MX-PN11B		---	OPT	OPT	OPT	OPT	OPT	OPT	
	MX-PN11C		---	OPT	OPT	OPT	OPT	OPT	OPT	
	MX-PN11D		---	OPT	OPT	OPT	OPT	OPT	OPT	
	MX-RB10	PAPER PASS UNIT	---	---	---	---	OPT	OPT	OPT	
	MX-FN10	FINISHER	---	---	---	---	OPT	OPT	OPT	
	MX-PNX5A	PUNCH MODULE	---	---	---	---	OPT	OPT	OPT	
	MX-PNX5B		---	---	---	---	OPT	OPT	OPT	
	MX-PNX5C		---	---	---	---	OPT	OPT	OPT	
	MX-PNX5D		---	---	---	---	OPT	OPT	OPT	
Printer expansion	MX-PB14	PRINTER EXPANSION KIT	OPT	OPT	OPT	OPT	STD	STD	STD	
	MX-PK11	PS3 EXPANSION KIT	OPT	OPT	OPT	OPT	OPT	OPT	OPT	*1
	MX-PUX1	XPS EXPANSION KIT	OPT	OPT	OPT	OPT	OPT	OPT	OPT	*1 *2
	MX-PF10	BARCODE FONT KIT	OPT	OPT	OPT	OPT	OPT	OPT	OPT	*1
Image send expansion	MX-FX11	FACSIMILE EXPANSION KIT	OPT	OPT	OPT	OPT	OPT	OPT	OPT	*3
	AR-SU1	STAMP UNIT	OPT	OPT	OPT	OPT	OPT	OPT	OPT	
	MX-FWX1	INTERNET FAX EXPANSION KIT	OPT	OPT	OPT	OPT	OPT	OPT	OPT	
	MX-EB11	ENHANCED COMPRESSION KIT	---	---	---	---	OPT	OPT	OPT	
Authentication/ Security	MX-FR25U	DATA SECURITY KIT	---	OPT	OPT	---	---	---	---	
	MX-FR34U	DATA SECURITY KIT	---	OPT	OPT	OPT	---	---	---	
	MX-FR30U	DATA SECURITY KIT	---	---	---	---	OPT	OPT	OPT	
	MX-EB12	MIRRORING KIT	---	---	---	---	OPT	OPT	OPT	
Application/ Solution	MX-USX1	SHARPDESK 1 LICENSE KIT	OPT	OPT	OPT	OPT	OPT	OPT	OPT	
	MX-USX5	Sharpdesk 5 license kit	OPT	OPT	OPT	OPT	OPT	OPT	OPT	
	MX-US10	SHARPDESK 10 LICENSE KIT	OPT	OPT	OPT	OPT	OPT	OPT	OPT	
	MX-US50	SHARPDESK 50 LICENSE KIT	OPT	OPT	OPT	OPT	OPT	OPT	OPT	
	MX-USA0	SHARPDESK 100 LICENSE KIT	OPT	OPT	OPT	OPT	OPT	OPT	OPT	
	MX-AMX1	APPLICATION INTEGRATION MODULE	OPT	OPT	OPT	OPT	OPT	OPT	OPT	
	MX-AMX2	APPLICATION COMMUNICATION MODULE	OPT	OPT	OPT	OPT	OPT	OPT	OPT	
	MX-AMX3	EXTERNAL ACCOUNT MODULE	OPT	OPT	OPT	OPT	OPT	OPT	OPT	
	MX-UN01A	Sharp OSA Network Scanner Tool 1 License Kit	OPT	OPT	OPT	OPT	OPT	OPT	OPT	
	MX-UN05A	Sharp OSA Network Scanner Tool 5 License Kit	OPT	OPT	OPT	OPT	OPT	OPT	OPT	
	MX-UN10A	Sharp OSA Network Scanner Tool 10 License Kit	OPT	OPT	OPT	OPT	OPT	OPT	OPT	
	MX-UN50A	Sharp OSA Network Scanner Tool 50 License Kit	OPT	OPT	OPT	OPT	OPT	OPT	OPT	
	MX-UN1HA	Sharp OSA Network Scanner Tool 100 License Kit	OPT	OPT	OPT	OPT	OPT	OPT	OPT	
	MX-KB11	KEYBOARD	---	---	---	---	OPT	STD/ OPT	STD/ OPT	*7
	MX-AM10	WEB BROWSING EXPANSION KIT	---	---	---	---	OPT	OPT	STD/ OPT	*7
Memory	MX-SM10	EXPANSION MEMORY BOARD	OPT	OPT	OPT	OPT	OPT	OPT	OPT	*5
Service	MX-SCX1	STAPLE CARTRIDGE	---	OPT	OPT	OPT	OPT	OPT	OPT	*4
	AR-SC3	STAPLE CARTRIDGE	---	---	---	---	OPT	OPT	OPT	*4
	AR-SV1	STAMP CARTRIDGE	OPT	OPT	OPT	OPT	OPT	OPT	OPT	
Other	MX-HD10	HARD DISK EXPANSION KIT	---	OPT	STD	STD	STD	STD	STD	
	MX-HD11	HARD DISK EXPANSION KIT	OPT	---	---	---	---	---	---	

STD: Standard equipment

OPT: Installable option

\*1: The printer expansion kit is required.

\*2: Memory expansion is required.

\*3: No support for some destinations.

\*4: Supply parts

\*5: Required when the XPS printer is used.

\*6: Option set for North America and Europe only.

\*7: Standard for North America only.

## [2] CONSUMABLE PARTS

### 1. Supply system table

#### A. 18cpm machine

##### (1) Europe

Item	Content	Life	Model name	Quantity in collective package	Remarks
Toner cartridge (Black)	Toner cartridge (Black toner) x 1	18K	MX-23GT-BA	10	* Life: A4/Letter size at area coverage 5% (Reference: 15K for A4/Letter 6%)
Toner cartridge (Cyan)	Toner cartridge (Cyan toner) x 1	10K	MX-23GT-CA	10	* Life: A4/Letter size at area coverage 5%
Toner cartridge (Magenta)	Toner cartridge (Magenta toner) x 1	10K	MX-23GT-MA	10	* Life: A4/Letter size at area coverage 5%
Toner cartridge (Yellow)	Toner cartridge (Yellow toner) x 1	10K	MX-23GT-YA	10	* Life: A4/Letter size at area coverage 5%
Developer (Black)	Developer (Black developer) x 1	80K	MX-36GV-BA	10	
Developer (Cyan/Magenta/Yellow: 3 colors/set)	Developer (Cyan/Magenta/Yellow: 3 colors/set) (Developer (each colors)) x 1	50K	MX-36GV-SA	10	
Drum	OPC drum x 1	80K (Black) 50K (Color)	MX-36GR-SA	10	
Drum unit	OPC drum unit (Process unit + OPC drum) x 1 Color identification seal (B/C/M/Y) x 1 each x 1 Charger cleaner x 1	80K (Black) 50K (Color)	MX-36GU-SA	10	

##### (2) Asia, Hong Kong

Item	Content	Life	Model name	Quantity in collective package	Remarks
Toner cartridge (Black)	Toner cartridge (Black toner) x 1	18K	MX-23AT-BA	10	* Life: A4/Letter size at area coverage 5% (Reference: 15K for A4/Letter 6%)
Toner cartridge (Cyan)	Toner cartridge (Cyan toner) x 1	10K	MX-23AT-CA	10	* Life: A4/Letter size at area coverage 5%
Toner cartridge (Magenta)	Toner cartridge (Magenta toner) x 1	10K	MX-23AT-MA	10	* Life: A4/Letter size at area coverage 5%
Toner cartridge (Yellow)	Toner cartridge (Yellow toner) x 1	10K	MX-23AT-YA	10	* Life: A4/Letter size at area coverage 5%
Developer (Black)	Developer (Black developer) x 1	80K	MX-36AV-BA	10	
Developer (Cyan/Magenta/Yellow: 3 colors/set)	Developer (Cyan/Magenta/Yellow: 3 colors/set) (Developer (each colors)) x 1	50K	MX-36AV-SA	10	
Drum	OPC drum x 1	80K (Black) 50K (Color)	MX-36AR-SA	10	
Drum unit	OPC drum unit (Process unit + OPC drum) x 1 Color identification seal (B/C/M/Y) x 1 each x 1 Charger cleaner x 1	80K (Black) 50K (Color)	MX-36AU-SA	10	

##### (3) Middle East, Africa

Item	Content	Life	Model name	Quantity in collective package	Remarks
Toner cartridge (Black)	Toner cartridge (Black toner) x 1	18K	MX-23FT-BA	10	* Life: A4/Letter size at area coverage 5% (Reference: 15K for A4/Letter 6%)
Toner cartridge (Cyan)	Toner cartridge (Cyan toner) x 1	10K	MX-23FT-CA	10	* Life: A4/Letter size at area coverage 5%
Toner cartridge (Magenta)	Toner cartridge (Magenta toner) x 1	10K	MX-23FT-MA	10	* Life: A4/Letter size at area coverage 5%
Toner cartridge (Yellow)	Toner cartridge (Yellow toner) x 1	10K	MX-23FT-YA	10	* Life: A4/Letter size at area coverage 5%
Developer (Black)	Developer (Black developer) x 1	80K	MX-36FV-BA	10	
Developer (Cyan/Magenta/Yellow: 3 colors/set)	Developer (Cyan/Magenta/Yellow: 3 colors/set) (Developer (each colors)) x 1	50K	MX-36FV-SA	10	

Item	Content	Life	Model name	Quantity in collective package	Remarks
Drum	OPC drum x 1	80K (Black) 50K (Color)	MX-36FR-SA	10	
Drum unit	OPC drum unit (Process unit + OPC drum) x 1 Color identification seal (B/C/M/Y) x 1 each x 1 Charger cleaner x 1	80K (Black) 50K (Color)	MX-36FU-SA	10	

#### (4) Taiwan

Item	Content	Life	Model name	Quantity in collective package	Remarks
Toner cartridge (Black)	Toner cartridge (Black toner) x 1	18K	MX-23FT-BA	10	* Life: A4/Letter size at area coverage 5% (Reference: 15K for A4/Letter 6%)
Toner cartridge (Cyan)	Toner cartridge (Cyan toner) x 1	10K	MX-23FT-CA	10	* Life: A4/Letter size at area coverage 5%
Toner cartridge (Magenta)	Toner cartridge (Magenta toner) x 1	10K	MX-23FT-MA	10	* Life: A4/Letter size at area coverage 5%
Toner cartridge (Yellow)	Toner cartridge (Yellow toner) x 1	10K	MX-23FT-YA	10	* Life: A4/Letter size at area coverage 5%
Toner Cartridge (Special Magenta)	Toner Cartridge (Special Magenta) x 1	10K	MX-23FT-MP	10	* Life: A4/Letter size at area coverage 5%
Developer (Black)	Developer (Black developer) x 1	80K	MX-36FV-BA	10	
Developer (Cyan/Magenta/Yellow: 3 colors/set)	Developer (Cyan/Magenta/Yellow: 3 colors/set) (Developer (each colors)) x 1	50K	MX-36FV-SA	10	
Developer (Cyan/Special Magenta/Yellow: 3 colors/set)	Developer (Cyan/Special Magenta/Yellow: 3 colors/set) (Developer (each colors)) x 1	80K (Black) 50K (Color)	MX-23FV-SP	10	
Drum	OPC drum x 1	80K (Black) 50K (Color)	MX-36FR-SA	10	
Drum unit	OPC drum unit (Process unit + OPC drum) x 1 Color identification seal (B/C/M/Y) x 1 each x 1 Charger cleaner x 1	100K (Black) 60K (Color)	MX-36FU-SA	10	

## B. 23cpm machine

### (1) North America, Middle America, South America (Except Brazil)

Item	Content	Life	Model name	Quantity in collective package	Remarks
Toner cartridge (Black)	Toner cartridge (Black toner) x 1	18K	MX-23NT-BA	10	* Life: A4/Letter size at area coverage 5% (Reference: 15K for A4/Letter 6%)
Toner cartridge (Cyan)	Toner cartridge (Cyan toner) x 1	10K	MX-23NT-CA	10	* Life: A4/Letter size at area coverage 5%
Toner cartridge (Magenta)	Toner cartridge (Magenta toner) x 1	10K	MX-23NT-MA	10	* Life: A4/Letter size at area coverage 5%
Toner cartridge (Yellow)	Toner cartridge (Yellow toner) x 1	10K	MX-23NT-YA	10	* Life: A4/Letter size at area coverage 5%
Developer (Black)	Developer (Black developer) x 1	100K	MX-36NV-BA	10	
Developer (Cyan/Magenta/Yellow: 3 colors/set)	Developer (Cyan/Magenta/Yellow: 3 colors/set) (Developer (each colors)) x 1	60K	MX-36NV-SA	10	
Drum	OPC drum x 1	100K (Black) 60K (Color)	MX-36NR-SA	10	
Drum unit	OPC drum unit (Process unit + OPC drum) x 1 Color identification seal (B/C/M/Y) x 1 each x 1 Charger cleaner x 1	100K (Black) 60K (Color)	MX-36NU-SA	10	

## C. 31cpm(G) machine

### (1) North America, Middle America, South America (Except Brazil)

Item	Content	Life	Model name	Quantity in collective package	Remarks
Toner cartridge (Black)	Toner cartridge (Black toner) x 1	18K	MX-23NT-BA	10	* Life: A4/Letter size at area coverage 5% (Reference: 15K for A4/Letter 6%)

Item	Content	Life	Model name	Quantity in collective package	Remarks	
Toner cartridge (Cyan)	Toner cartridge (Cyan toner)	x 1	10K	MX-23NT-CA	10	* Life: A4/Letter size at area coverage 5%
Toner cartridge (Magenta)	Toner cartridge (Magenta toner)	x 1	10K	MX-23NT-MA	10	* Life: A4/Letter size at area coverage 5%
Toner cartridge (Yellow)	Toner cartridge (Yellow toner)	x 1	10K	MX-23NT-YA	10	* Life: A4/Letter size at area coverage 5%
Developer (Black)	Developer (Black developer)	x 1	100K	MX-36NV-BA	10	
Developer (Cyan/Magenta/Yellow: 3 colors/set)	Developer (Cyan/Magenta/Yellow: 3 colors/set) (Developer (each colors))	x 1	60K	MX-36NV-SA	10	
Drum	OPC drum	x 1	100K (Black) 60K (Color)	MX-36NR-SA	10	
Drum unit	OPC drum unit (Process unit + OPC drum) Color identification seal (B/C/M/Y) x 1 each Charger cleaner	x 1 x 1 x 1	100K (Black) 60K (Color)	MX-36NU-SB	10	

## D. 20cpm/23cpm/31cpm(G) machine

### (1) Europe, Eastern Europe, Russia, Australia, New Zealand

Item	Content	Life	Model name	Quantity in collective package	Remarks	
Toner cartridge (Black)	Toner cartridge (Black toner)	x 1	18K	MX-23GT-BA	10	* Life: A4/Letter size at area coverage 5% (Reference: 15K for A4/Letter 6%)
Toner cartridge (Cyan)	Toner cartridge (Cyan toner)	x 1	10K	MX-23GT-CA	10	* Life: A4/Letter size at area coverage 5%
Toner cartridge (Magenta)	Toner cartridge (Magenta toner)	x 1	10K	MX-23GT-MA	10	* Life: A4/Letter size at area coverage 5%
Toner cartridge (Yellow)	Toner cartridge (Yellow toner)	x 1	10K	MX-23GT-YA	10	* Life: A4/Letter size at area coverage 5%
Developer (Black)	Developer (Black developer)	x 1	100K	MX-36GV-BA	10	
Developer (Cyan/Magenta/Yellow: 3 colors/set)	Developer (Cyan/Magenta/Yellow: 3 colors/set) (Developer (each colors))	x 1	60K	MX-36GV-SA	10	
Drum	OPC drum	x 1	100K (Black) 60K (Color)	MX-36GR-SA	10	
Drum unit	OPC drum unit (Process unit + OPC drum) Color identification seal (B/C/M/Y) x 1 each Charger cleaner	x 1 x 1 x 1	100K (Black) 60K (Color)	MX-36GU-SA	10	

### (2) Asia, Hong Kong

Item	Content	Life	Model name	Quantity in collective package	Remarks	
Toner cartridge (Black)	Toner cartridge (Black toner)	x 1	18K	MX-23AT-BA	10	* Life: A4/Letter size at area coverage 5% (Reference: 15K for A4/Letter 6%)
Toner cartridge (Cyan)	Toner cartridge (Cyan toner)	x 1	10K	MX-23AT-CA	10	* Life: A4/Letter size at area coverage 5%
Toner cartridge (Magenta)	Toner cartridge (Magenta toner)	x 1	10K	MX-23AT-MA	10	* Life: A4/Letter size at area coverage 5%
Toner cartridge (Yellow)	Toner cartridge (Yellow toner)	x 1	10K	MX-23AT-YA	10	* Life: A4/Letter size at area coverage 5%
Developer (Black)	Developer (Black developer)	x 1	100K	MX-36AV-BA	10	
Developer (Cyan/Magenta/Yellow: 3 colors/set)	Developer (Cyan/Magenta/Yellow: 3 colors/set) (Developer (each colors))	x 1	60K	MX-36AV-SA	10	
Drum	OPC drum	x 1	100K (Black) 60K (Color)	MX-36AR-SA	10	
Drum unit	OPC drum unit (Process unit + OPC drum) Color identification seal (B/C/M/Y) x 1 each Charger cleaner	x 1 x 1 x 1	100K (Black) 60K (Color)	MX-36AU-SA	10	

### (3) Middle East, Africa

Item	Content	Life	Model name	Quantity in collective package	Remarks
Toner cartridge (Black)	Toner cartridge (Black toner) x 1	18K	MX-23FT-BA	10	* Life: A4/Letter size at area coverage 5% (Reference: 15K for A4/Letter 6%)
Toner cartridge (Cyan)	Toner cartridge (Cyan toner) x 1	10K	MX-23FT-CA	10	* Life: A4/Letter size at area coverage 5%
Toner cartridge (Magenta)	Toner cartridge (Magenta toner) x 1	10K	MX-23FT-MA	10	* Life: A4/Letter size at area coverage 5%
Toner cartridge (Yellow)	Toner cartridge (Yellow toner) x 1	10K	MX-23FT-YA	10	* Life: A4/Letter size at area coverage 5%
Developer (Black)	Developer (Black developer) x 1	100K	MX-36FV-BA	10	
Developer (Cyan/Magenta/Yellow: 3 colors/set)	Developer (Cyan/Magenta/Yellow: 3 colors/set) (Developer (each colors)) x 1	60K	MX-36FV-SA	10	
Drum	OPC drum x 1	100K (Black) 60K (Color)	MX-36FR-SA	10	
Drum unit	OPC drum unit (Process unit + OPC drum) x 1 Color identification seal (B/C/M/Y) x 1 each x 1 Charger cleaner x 1	100K (Black) 60K (Color)	MX-36FU-SA	10	

### (4) Taiwan

Item	Content	Life	Model name	Quantity in collective package	Remarks
Toner cartridge (Black)	Toner cartridge (Black toner) x 1	18K	MX-23FT-BA	10	* Life: A4/Letter size at area coverage 5% (Reference: 15K for A4/Letter 6%)
Toner cartridge (Cyan)	Toner cartridge (Cyan toner) x 1	10K	MX-23FT-CA	10	* Life: A4/Letter size at area coverage 5%
Toner cartridge (Magenta)	Toner cartridge (Magenta toner) x 1	10K	MX-23FT-MA	10	* Life: A4/Letter size at area coverage 5%
Toner cartridge (Yellow)	Toner cartridge (Yellow toner) x 1	10K	MX-23FT-YA	10	* Life: A4/Letter size at area coverage 5%
Toner Cartridge (Special Magenta)	Toner Cartridge (Special Magenta) x 1	10K	MX-23FT-MP	10	* Life: A4/Letter size at area coverage 5%
Developer (Black)	Developer (Black developer) x 1	100K	MX-36FV-BA	10	
Developer (Cyan/Magenta/Yellow: 3 colors/set)	Developer (Cyan/Magenta/Yellow: 3 colors/set) (Developer (each colors)) x 1	60K	MX-36FV-SA	10	
Developer (Cyan/Special Magenta/Yellow: 3 colors/set)	Developer (Cyan/Special Magenta/Yellow: 3 colors/set) (Developer (each colors)) x 1	60K	MX-23FV-SP	10	
Drum	OPC drum x 1	100K (Black) 60K (Color)	MX-36FR-SA	10	
Drum unit	OPC drum unit (Process unit + OPC drum) x 1 Color identification seal (B/C/M/Y) x 1 each x 1 Charger cleaner x 1	100K (Black) 60K (Color)	MX-36FU-SA	10	

## E. 26cpm/31cpm(A) machine

### (1) North America, Middle America, South America (Except Brazil)

Item	Content	Life	Model name	Quantity in collective package	Remarks
Toner cartridge (Black)	Toner cartridge (Black toner) x 1	24K	MX-36NT-BA	10	* Life: A4/Letter size at area coverage 5% (Reference: 20K for A4/Letter 6%)
Toner cartridge (Cyan)	Toner cartridge (Cyan toner) x 1	15K	MX-36NT-CA	10	* Life: A4/Letter size at area coverage 5%
Toner cartridge (Magenta)	Toner cartridge (Magenta toner) x 1	15K	MX-36NT-MA	10	* Life: A4/Letter size at area coverage 5%
Toner cartridge (Yellow)	Toner cartridge (Yellow toner) x 1	15K	MX-36NT-YA	10	* Life: A4/Letter size at area coverage 5%
Developer (Black)	Developer (Black developer) x 1	100K	MX-36NV-BA	10	
Developer (Cyan/Magenta/Yellow: 3 colors/set)	Developer (Cyan/Magenta/Yellow: 3 colors/set) (Developer (each colors)) x 1	60K	MX-36NV-SA	10	



Item	Content	Life	Model name	Quantity in collective package	Remarks
Drum	OPC drum x 1	100K (Black) 60K (Color)	MX-36NR-SA	10	
Drum unit	OPC drum unit (Process unit + OPC drum) x 1 Color identification seal (B/C/M/Y) x 1 each x 1 Charger cleaner x 1	100K (Black) 60K (Color)	MX-36NU-SB	10	

## (2) Europe, Eastern Europe, Russia, Australia, New Zealand

Item	Content	Life	Model name	Quantity in collective package	Remarks
Toner cartridge (Black)	Toner cartridge (Black toner) x 1	24K	MX-36GT-BA	10	* Life: A4/Letter size at area coverage 5% (Reference: 20K for A4/Letter 6%)
Toner cartridge (Cyan)	Toner cartridge (Cyan toner) x 1	15K	MX-36GT-CA	10	* Life: A4/Letter size at area coverage 5%
Toner cartridge (Magenta)	Toner cartridge (Magenta toner) x 1	15K	MX-36GT-MA	10	* Life: A4/Letter size at area coverage 5%
Toner cartridge (Yellow)	Toner cartridge (Yellow toner) x 1	15K	MX-36GT-YA	10	* Life: A4/Letter size at area coverage 5%
Developer (Black)	Developer (Black developer) x 1	100K	MX-36GV-BA	10	
Developer (Cyan/Magenta/Yellow: 3 colors/set)	Developer (Cyan/Magenta/Yellow: 3 colors/set) (Developer (each colors)) x 1	60K	MX-36GV-SA	10	
Drum	OPC drum x 1	100K (Black) 60K (Color)	MX-36GR-SA	10	
Drum unit	OPC drum unit (Process unit + OPC drum) x 1 Color identification seal (B/C/M/Y) x 1 each x 1 Charger cleaner x 1	100K (Black) 60K (Color)	MX-36GU-SA	10	

## (3) Asia, Hong Kong

Item	Content	Life	Model name	Quantity in collective package	Remarks
Toner cartridge (Black)	Toner cartridge (Black toner) x 1	24K	MX-36AT-BA	10	* Life: A4/Letter size at area coverage 5% (Reference: 20K for A4/Letter 6%)
Toner cartridge (Cyan)	Toner cartridge (Cyan toner) x 1	15K	MX-36AT-CA	10	* Life: A4/Letter size at area coverage 5%
Toner cartridge (Magenta)	Toner cartridge (Magenta toner) x 1	15K	MX-36AT-MA	10	* Life: A4/Letter size at area coverage 5%
Toner cartridge (Yellow)	Toner cartridge (Yellow toner) x 1	15K	MX-36AT-YA	10	* Life: A4/Letter size at area coverage 5%
Developer (Black)	Developer (Black developer) x 1	100K	MX-36AV-BA	10	
Developer (Cyan/Magenta/Yellow: 3 colors/set)	Developer (Cyan/Magenta/Yellow: 3 colors/set) (Developer (each colors)) x 1	60K	MX-36AV-SA	10	
Drum	OPC drum x 1	100K (Black) 60K (Color)	MX-36AR-SA	10	
Drum unit	OPC drum unit (Process unit + OPC drum) x 1 Color identification seal (B/C/M/Y) x 1 each x 1 Charger cleaner x 1	100K (Black) 60K (Color)	MX-36AU-SA	10	

## (4) Middle East, Taiwan, Africa

Item	Content	Life	Model name	Quantity in collective package	Remarks
Toner cartridge (Black)	Toner cartridge (Black toner) x 1	24K	MX-36FT-BA	10	* Life: A4/Letter size at area coverage 5% (Reference: 20K for A4/Letter 6%)
Toner cartridge (Cyan)	Toner cartridge (Cyan toner) x 1	15K	MX-36FT-CA	10	* Life: A4/Letter size at area coverage 5%
Toner cartridge (Magenta)	Toner cartridge (Magenta toner) x 1	15K	MX-36FT-MA	10	* Life: A4/Letter size at area coverage 5%
Toner cartridge (Yellow)	Toner cartridge (Yellow toner) x 1	15K	MX-36FT-YA	10	* Life: A4/Letter size at area coverage 5%
Developer (Black)	Developer (Black developer) x 1	100K	MX-36FV-BA	10	

Item	Content	Life	Model name	Quantity in collective package	Remarks	
Developer (Cyan/Magenta/Yellow: 3 colors/set)	Developer (Cyan/Magenta/Yellow: 3 colors/set) (Developer (each colors))	x 1	60K	MX-36FV-SA	10	
Drum	OPC drum	x 1	100K (Black) 60K (Color)	MX-36FR-SA	10	
Drum unit	OPC drum unit (Process unit + OPC drum) Color identification seal (B/C/M/Y) x 1 each Charger cleaner	x 1 x 1 x 1	100K (Black) 60K (Color)	MX-36FU-SA	10	

## F. 36cpm machine

### (1) North America, Middle America, South America (Except Brazil)

Item	Content	Life	Model name	Quantity in collective package	Remarks	
Toner cartridge (Black)	Toner cartridge (Black toner)	x 1	24K	MX-36NT-BA	10	* Life: A4/Letter size at area coverage 5% (Reference: 20K for A4/Letter 6%)
Toner cartridge (Cyan)	Toner cartridge (Cyan toner)	x 1	15K	MX-36NT-CA	10	* Life: A4/Letter size at area coverage 5%
Toner cartridge (Magenta)	Toner cartridge (Magenta toner)	x 1	15K	MX-36NT-MA	10	* Life: A4/Letter size at area coverage 5%
Toner cartridge (Yellow)	Toner cartridge (Yellow toner)	x 1	15K	MX-36NT-YA	10	* Life: A4/Letter size at area coverage 5%
Developer (Black)	Developer (Black developer)	x 1	120K	MX-36NV-BA	10	
Developer (Cyan/Magenta/Yellow: 3 colors/set)	Developer (Cyan/Magenta/Yellow: 3 colors/set) (Developer (each colors))	x 1	70K	MX-36NV-SA	10	
Drum	OPC drum	x 1	120K (Black) 70K (Color)	MX-36NR-SA	10	
Drum unit	OPC drum unit (Process unit + OPC drum) Color identification seal (B/C/M/Y) x 1 each Charger cleaner	x 1 x 1 x 1	120K (Black) 70K (Color)	MX-36NU-SB	10	

### (2) Europe, Eastern Europe, Russia, Australia, New Zealand

Item	Content	Life	Model name	Quantity in collective package	Remarks	
Toner cartridge (Black)	Toner cartridge (Black toner)	x 1	24K	MX-36GT-BA	10	* Life: A4/Letter size at area coverage 5% (Reference: 20K for A4/Letter 6%)
Toner cartridge (Cyan)	Toner cartridge (Cyan toner)	x 1	15K	MX-36GT-CA	10	* Life: A4/Letter size at area coverage 5%
Toner cartridge (Magenta)	Toner cartridge (Magenta toner)	x 1	15K	MX-36GT-MA	10	* Life: A4/Letter size at area coverage 5%
Toner cartridge (Yellow)	Toner cartridge (Yellow toner)	x 1	15K	MX-36GT-YA	10	* Life: A4/Letter size at area coverage 5%
Developer (Black)	Developer (Black developer)	x 1	120K	MX-36GV-BA	10	
Developer (Cyan/Magenta/Yellow: 3 colors/set)	Developer (Cyan/Magenta/Yellow: 3 colors/set) (Developer (each colors))	x 1	70K	MX-36GV-SA	10	
Drum	OPC drum	x 1	120K (Black) 70K (Color)	MX-36GR-SA	10	
Drum unit	OPC drum unit (Process unit + OPC drum) Color identification seal (B/C/M/Y) x 1 each Charger cleaner	x 1 x 1 x 1	120K (Black) 70K (Color)	MX-36GU-SA	10	

### (3) Asia, Hong Kong

Item	Content	Life	Model name	Quantity in collective package	Remarks	
Toner cartridge (Black)	Toner cartridge (Black toner)	x 1	24K	MX-36AT-BA	10	* Life: A4/Letter size at area coverage 5% (Reference: 20K for A4/Letter 6%)
Toner cartridge (Cyan)	Toner cartridge (Cyan toner)	x 1	15K	MX-36AT-CA	10	* Life: A4/Letter size at area coverage 5%
Toner cartridge (Magenta)	Toner cartridge (Magenta toner)	x 1	15K	MX-36AT-MA	10	* Life: A4/Letter size at area coverage 5%

Item	Content	Life	Model name	Quantity in collective package	Remarks
Toner cartridge (Yellow)	Toner cartridge (Yellow toner) x 1	15K	MX-36AT-YA	10	* Life: A4/Letter size at area coverage 5%
Developer (Black)	Developer (Black developer) x 1	120K	MX-36AV-BA	10	
Developer (Cyan/Magenta/Yellow: 3 colors/set)	Developer (Cyan/Magenta/Yellow: 3 colors/set) (Developer (each colors)) x 1	70K	MX-36AV-SA	10	
Drum	OPC drum x 1	120K (Black) 70K (Color)	MX-36AR-SA	10	
Drum unit	OPC drum unit (Process unit + OPC drum) x 1 Color identification seal (B/C/M/Y) x 1 each x 1 Charger cleaner x 1	120K (Black) 70K (Color)	MX-36AU-SA	10	

#### (4) Middle East, Taiwan, Africa

Item	Content	Life	Model name	Quantity in collective package	Remarks
Toner cartridge (Black)	Toner cartridge (Black toner) x 1	24K	MX-36FT-BA	10	* Life: A4/Letter size at area coverage 5% (Reference: 20K for A4/Letter 6%)
Toner cartridge (Cyan)	Toner cartridge (Cyan toner) x 1	15K	MX-36FT-CA	10	* Life: A4/Letter size at area coverage 5%
Toner cartridge (Magenta)	Toner cartridge (Magenta toner) x 1	15K	MX-36FT-MA	10	* Life: A4/Letter size at area coverage 5%
Toner cartridge (Yellow)	Toner cartridge (Yellow toner) x 1	15K	MX-36FT-YA	10	* Life: A4/Letter size at area coverage 5%
Developer (Black)	Developer (Black developer) x 1	120K	MX-36FV-BA	10	
Developer (Cyan/Magenta/Yellow: 3 colors/set)	Developer (Cyan/Magenta/Yellow: 3 colors/set) (Developer (each colors)) x 1	70K	MX-36FV-SA	10	
Drum	OPC drum x 1	120K (Black) 70K (Color)	MX-36FR-SA	10	
Drum unit	OPC drum unit (Process unit + OPC drum) x 1 Color identification seal (B/C/M/Y) x 1 each x 1 Charger cleaner x 1	120K (Black) 70K (Color)	MX-36FU-SA	10	

## 2. Maintenance parts list

### A. 18cpm machine

#### (1) Europe, Taiwan

Item	Model name	Content	Life	Quantity in collective package	Remarks
Upper heat roller kit	MX-200UH	Upper heat roller x 1	80K	10	
Lower heat roller kit	MX-200LH	Lower heat roller x 1	80K	10	
Fusing cleaning kit	MX-230CR	Lower oil roller x 1 Lower CL roller x 1 Lower CL roller bearing x 2 Lower CL scraper x 1	80K	10	
Primary transfer belt kit	MX-230B1	Primary transfer belt AR x 1	80K	10	
Primary transfer blade kit	MX-230TL	Primary transfer blade AR x 1	80K	10	
PTC kit	MX-230CU	PTC unit x 1	80K	10	
Secondary transfer belt kit	MX-230B2	Secondary transfer belt D3 x 1	240K	10	
PS paper dust removing unit	MX-230PD	PS paper dust removing unit x 1	80K	10	
Filter kit	MX-C31FL	Ozone filter x 1	80K	10	
Toner collection container	MX-230HB	Toner collection container (with LSU cleaner x 2) x 1	50K	5	5% coverage for each color; 25% color ratio
Main charger kit	MX-230MK	Main charger unit x 1 Cleaning gum AS AR x 1 Cleaning blade AR x 1	Black: 80K Color: 50K	10	
Staple cartridge	MX-SCX1	Staple cartridge x 3	5000 times x 3	20	For MX-FN17
Finish stamp cartridge	AR-SV1	Finish stamp cartridge x 2	—	20	
Primary transfer belt unit	MX-230U1	Primary transfer belt unit (For servicing rotation) x 1	—	1	
Secondary transfer belt unit	MX-230U2	Secondary transfer belt unit (For servicing rotation) x 1	—	1	
Fusing unit	MX-200FU	Fusing unit (For servicing rotation: Heater lamp 230V) x 1	—	1	
Fusing unit	MX-200FU2	Fusing unit (For servicing rotation: Heater lamp 110V) x 1	—	1	

**Note**

When shipping, the parts are packed in the unit of 10 sets. In the market, however, they are treated in the unit of 1 set.

Model name: Composed of the parts of 1 set

**(2) Singapore, Thailand, Malaysia, India, Middle east, Other countries**

Item	Model name	Content	Life	Quantity in collective package	Remarks
Upper heat roller kit	MX-200UH	Upper heat roller x 1	80K	10	
Lower heat roller kit	MX-200LH	Lower heat roller x 1	80K	10	
Fusing cleaning kit	MX-230CR	Lower oil roller x 1 Lower CL roller x 1 Lower CL roller bearing x 2 Lower CL scraper x 1	80K	10	
Primary transfer belt kit	MX-230B1	Primary transfer belt AR x 1	80K	10	
Primary transfer blade kit	MX-230TL	Primary transfer blade AR x 1	80K	10	
PTC kit	MX-230CU	PTC unit x 1	80K	10	
Secondary transfer belt kit	MX-230B2	Secondary transfer belt D3 x 1	240K	10	
PS paper dust removing unit	MX-230PD	PS paper dust removing unit x 1	80K	10	
Filter kit	MX-C31FL	Ozone filter x 1	80K	10	
Toner collection container	MX-230HB	Toner collection container (with LSU cleaner x 2) x 1	50K	5	5% coverage for each color; 25% color ratio
Main charger kit	MX-230MK	Main charger unit x 1 Cleaning gum AS AR x 1 Cleaning blade AR x 1	Black: 80K Color: 50K	10	
Staple cartridge	MX-SCX1	Staple cartridge x 3	5000 times x 3	20	For MX-FN17
Finish stamp cartridge	AR-SV1	Finish stamp cartridge x 2	—	20	
Primary transfer belt unit	MX-230U1	Primary transfer belt unit (For servicing rotation) x 1	—	1	
Secondary transfer belt unit	MX-230U2	Secondary transfer belt unit (For servicing rotation) x 1	—	1	
Fusing unit	MX-200FU	Fusing unit (For servicing rotation: Heater lamp 230V) x 1	—	1	

**Note**

When shipping, the parts are packed in the unit of 10 sets. In the market, however, they are treated in the unit of 1 set.

Model name: Composed of the parts of 1 set

**B. 20cpm machine****(1) Europe, UK, Australia, New Zealand, Taiwan**

Item	Model name	Content	Life	Quantity in collective package	Remarks
Upper heat roller kit	MX-200UH	Upper heat roller x 1	100K	10	
Lower heat roller kit	MX-200LH	Lower heat roller x 1	100K	10	
Fusing cleaning kit	MX-230CR	Lower oil roller x 1 Lower CL roller x 1 Lower CL roller bearing x 2 Lower CL scraper x 1	100K	10	
Primary transfer belt kit	MX-230B1	Primary transfer belt AR x 1	100K	10	
Primary transfer blade kit	MX-230TL	Primary transfer blade AR x 1	100K	10	
PTC kit	MX-230CU	PTC unit x 1	100K	10	
Secondary transfer belt kit	MX-230B2	Secondary transfer belt D3 x 1	300K	10	
PS paper dust removing unit	MX-230PD	PS paper dust removing unit x 1	100K	10	
Filter kit	MX-C31FL	Ozone filter x 1	100K	10	
Toner collection container	MX-230HB	Toner collection container (with LSU cleaner x 2) x 1	50K	5	5% coverage for each color; 25% color ratio
Main charger kit	MX-230MK	Main charger unit x 1 Cleaning gum AS AR x 1 Cleaning blade AR x 1	Black: 100K Color: 60K	10	
Staple cartridge	MX-SCX1	Staple cartridge x 3	5000 times x 3	20	For MX-FN17
Finish stamp cartridge	AR-SV1	Finish stamp cartridge x 2	—	20	
Primary transfer belt unit	MX-230U1	Primary transfer belt unit (For servicing rotation) x 1	—	1	
Secondary transfer belt unit	MX-230U2	Secondary transfer belt unit (For servicing rotation) x 1	—	1	
Fusing unit	MX-200FU	Fusing unit (For servicing rotation: Heater lamp 230V) x 1	—	1	
Fusing unit	MX-200FU2	Fusing unit (For servicing rotation: Heater lamp 110V) x 1	—	1	

**Note**

When shipping, the parts are packed in the unit of 10 sets. In the market, however, they are treated in the unit of 1 set.

Model name: Composed of the parts of 1 set

**(2) Singapore, Thailand, Malaysia, India, Middle east, Other countries**

Item	Model name	Content	Life	Quantity in collective package	Remarks
Upper heat roller kit	MX-200UH	Upper heat roller x 1	100K	10	
Lower heat roller kit	MX-200LH	Lower heat roller x 1	100K	10	
Fusing cleaning kit	MX-230CR	Lower oil roller x 1 Lower CL roller x 1 Lower CL roller bearing x 2 Lower CL scraper x 1	100K	10	
Primary transfer belt kit	MX-230B1	Primary transfer belt AR x 1	100K	10	
Primary transfer blade kit	MX-230TL	Primary transfer blade AR x 1	100K	10	
PTC kit	MX-230CU	PTC unit x 1	100K	10	
Secondary transfer belt kit	MX-230B2	Secondary transfer belt D3 x 1	300K	10	
PS paper dust removing unit	MX-230PD	PS paper dust removing unit x 1	100K	10	
Filter kit	MX-C31FL	Ozone filter x 1	100K	10	
Toner collection container	MX-230HB	Toner collection container (with LSU cleaner x 2) x 1	50K	5	5% coverage for each color; 25% color ratio
Main charger kit	MX-230MK	Main charger unit x 1 Cleaning gum AS AR x 1 Cleaning blade AR x 1	Black: 100K Color: 60K	10	
Staple cartridge	MX-SCX1	Staple cartridge x 3	5000 times x 3	20	For MX-FN17
Finish stamp cartridge	AR-SV1	Finish stamp cartridge x 2	—	20	
Primary transfer belt unit	MX-230U1	Primary transfer belt unit (For servicing rotation) x 1	—	1	
Secondary transfer belt unit	MX-230U2	Secondary transfer belt unit (For servicing rotation) x 1	—	1	
Fusing unit	MX-200FU1	Fusing unit (For servicing rotation: Heater lamp 120V) x 1	—	1	
Fusing unit	MX-200FU	Fusing unit (For servicing rotation: Heater lamp 230V) x 1	—	1	

**Note**

When shipping, the parts are packed in the unit of 10 sets. In the market, however, they are treated in the unit of 1 set.

Model name: Composed of the parts of 1 set

**(3) Hong Kong**

Item	Model name	Content	Life	Quantity in collective package	Remarks
Upper heat roller kit	MX-200UH	Upper heat roller x 1	100K	10	
Lower heat roller kit	MX-200LH	Lower heat roller x 1	100K	10	
Fusing cleaning kit	MX-230CR	Lower oil roller x 1 Lower CL roller x 1 Lower CL roller bearing x 2 Lower CL scraper x 1	100K	10	
Primary transfer belt kit	MX-230B1	Primary transfer belt AR x 1	100K	10	
Primary transfer blade kit	MX-230TL	Primary transfer blade AR x 1	100K	10	
PTC kit	MX-230CU	PTC unit x 1	100K	10	
Secondary transfer belt kit	MX-230B2	Secondary transfer belt D3 x 1	300K	10	
PS paper dust removing unit	MX-230PD	PS paper dust removing unit x 1	100K	10	
Filter kit	MX-C31FL	Ozone filter x 1	100K	10	
Toner collection container	MX-230HB	Toner collection container (with LSU cleaner x 2) x 1	50K	5	5% coverage for each color; 25% color ratio
Main charger kit	MX-230MK	Main charger unit x 1 Cleaning gum AS AR x 1 Cleaning blade AR x 1	Black: 100K Color: 60K	10	
Staple cartridge	MX-SCX1	Staple cartridge x 3	5000 times x 3	20	For MX-FN17
Finish stamp cartridge	AR-SV1	Finish stamp cartridge x 2	—	20	
Primary transfer belt unit	MX-230U1	Primary transfer belt unit (For servicing rotation) x 1	—	1	
Secondary transfer belt unit	MX-230U2	Secondary transfer belt unit (For servicing rotation) x 1	—	1	
Fusing unit	MX-200FU	Fusing unit (For servicing rotation: Heater lamp 230V) x 1	—	1	

**Note**

When shipping, the parts are packed in the unit of 10 sets. In the market, however, they are treated in the unit of 1 set.

Model name: Composed of the parts of 1 set

**Note**

The numbers in the column of "Quantity in collective package" in the above list indicate the quantities for one package shipped from the factory. Since, however, the products are treated as one piece or one set, their model names and necessary quantities must be specified when ordering. Pay attention to that.

**C. 23cpm machine****(1) North America, Middle America, South America**

Item	Model name	Content	Life	Quantity in collective package	Remarks
Fusing belt kit	MX-230FB	Fusing belt x 1 Fuser belt guide collar x 2	100K	10	
Pressure roller kit	MX-230LH	Fusing roller x 1 Pressure roller x 1	200K	10	
Fusing cleaning kit	MX-230CR	Lower oil roller x 1 Lower CL roller x 1 Lower CL roller bearing x 2 Lower CL scraper x 1	100K	10	
Primary transfer belt kit	MX-230B1	Primary transfer belt AR x 1	100K	10	
Primary transfer blade kit	MX-230TL	Primary transfer blade AR x 1	100K	10	
PTC kit	MX-230CU	PTC unit x 1	100K	10	
Secondary transfer belt kit	MX-230B2	Secondary transfer belt D3 x 1	300K	10	
PS paper dust removing unit	MX-230PD	PS paper dust removing unit x 1	100K	10	
Filter kit	MX-C31FL	Ozone filter x 1	100K	10	
Toner collection container	MX-230HB	Toner collection container (with LSU cleaner x 2) x 1	50K	5	5% coverage for each color; 25% color ratio
Main charger kit	MX-230MK	Main charger unit x 1 Cleaning gum AS AR x 1 Cleaning blade AR x 1	Black: 100K Color: 60K	10	
Staple cartridge	MX-SCX1	Staple cartridge x 3	5000 times x 3	20	For inner finisher (MX-FN17)
Finish stamp cartridge	AR-SV1	Finish stamp cartridge x 2	—	20	
Primary transfer belt unit	MX-230U1	Primary transfer belt unit (For servicing rotation) x 1	—	1	
Secondary transfer belt unit	MX-230U2	Secondary transfer belt unit (For servicing rotation) x 1	—	1	
Fusing unit	MX-230FU1	Fusing unit (For servicing rotation: Heater lamp 120V) x 1	—	1	
Fusing unit	MX-230FU	Fusing unit (For servicing rotation: Heater lamp 230V) x 1	—	1	

**Note**

When shipping, the parts are packed in the unit of 10 sets. In the market, however, they are treated in the unit of 1 set. Model name: Composed of the parts of 1 set

**(2) Europe, Eastern Europe, Russia, Australia, New Zealand**

Item	Model name	Content	Life	Quantity in collective package	Remarks
Fusing belt kit	MX-230FB	Fusing belt x 1 Fuser belt guide collar x 2	100K	10	
Pressure roller kit	MX-230LH	Fusing roller x 1 Pressure roller x 1	200K	10	
Fusing cleaning kit	MX-230CR	Lower oil roller x 1 Lower CL roller x 1 Lower CL roller bearing x 2 Lower CL scraper x 1	100K	10	
Primary transfer belt kit	MX-230B1	Primary transfer belt AR x 1	100K	10	
Primary transfer blade kit	MX-230TL	Primary transfer blade AR x 1	100K	10	
PTC kit	MX-230CU	PTC unit x 1	100K	10	
Secondary transfer belt kit	MX-230B2	Secondary transfer belt D3 x 1	300K	10	
PS paper dust removing unit	MX-230PD	PS paper dust removing unit x 1	100K	10	
Filter kit	MX-C31FL	Ozone filter x 1	100K	10	
Toner collection container	MX-230HB	Toner collection container (with LSU cleaner x 2) x 1	50K	5	5% coverage for each color; 25% color ratio
Main charger kit	MX-230MK	Main charger unit x 1 Cleaning gum AS AR x 1 Cleaning blade AR x 1	Black: 100K Color: 60K	10	
Staple cartridge	MX-SCX1	Staple cartridge x 3	5000 times x 3	20	For MX-FN17
Finish stamp cartridge	AR-SV1	Finish stamp cartridge x 2	—	20	

Item	Model name	Content	Life	Quantity in collective package	Remarks
Primary transfer belt unit	MX-230U1	Primary transfer belt unit (For servicing rotation)	x 1	—	1
Secondary transfer belt unit	MX-230U2	Secondary transfer belt unit (For servicing rotation)	x 1	—	1
Fusing unit	MX-230FU	Fusing unit (For servicing rotation: Heater lamp 230V)	x 1	—	1

### Note

When shipping, the parts are packed in the unit of 10 sets. In the market, however, they are treated in the unit of 1 set.

Model name: Composed of the parts of 1 set

### (3) Asia, Middle East

Item	Model name	Content	Life	Quantity in collective package	Remarks	
Fusing belt kit	MX-230FB	Fusing belt Fuser belt guide collar	x 1 x 2	100K	10	
Pressure roller kit	MX-230LH	Fusing roller Pressure roller	x 1 x 1	200K	10	
Fusing cleaning kit	MX-230CR	Lower oil roller Lower CL roller Lower CL roller bearing Lower CL scraper	x 1 x 1 x 2 x 1	100K	10	
Primary transfer belt kit	MX-230B1	Primary transfer belt AR	x 1	100K	10	
Primary transfer blade kit	MX-230TL	Primary transfer blade AR	x 1	100K	10	
PTC kit	MX-230CU	PTC unit	x 1	100K	10	
Secondary transfer belt kit	MX-230B2	Secondary transfer belt D3	x 1	300K	10	
PS paper dust removing unit	MX-230PD	PS paper dust removing unit	x 1	100K	10	
Filter kit	MX-C31FL	Ozone filter	x 1	100K	10	
Toner collection container	MX-230HB	Toner collection container (with LSU cleaner x 2)	x 1	50K	5	5% coverage for each color; 25% color ratio
Main charger kit	MX-230MK	Main charger unit Cleaning gum AS AR Cleaning blade AR	x 1 x 1 x 1	Black: 100K Color: 60K	10	
Staple cartridge	MX-SCX1	Staple cartridge	x 3	5000 times x 3	20	For MX-FN17
Finish stamp cartridge	AR-SV1	Finish stamp cartridge	x 2	—	20	
Primary transfer belt unit	MX-230U1	Primary transfer belt unit (For servicing rotation)	x 1	—	1	
Secondary transfer belt unit	MX-230U2	Secondary transfer belt unit (For servicing rotation)	x 1	—	1	
Fusing unit	MX-230FU1	Fusing unit (For servicing rotation: Heater lamp 120V)	x 1	—	1	
Fusing unit	MX-230FU	Fusing unit (For servicing rotation: Heater lamp 230V)	x 1	—	1	

### Note

When shipping, the parts are packed in the unit of 10 sets. In the market, however, they are treated in the unit of 1 set.

Model name: Composed of the parts of 1 set

### (4) Hong Kong

Item	Model name	Content	Life	Quantity in collective package	Remarks	
Fusing belt kit	MX-230FB	Fusing belt Fuser belt guide collar	x 1 x 2	100K	10	
Pressure roller kit	MX-230LH	Fusing roller Pressure roller	x 1 x 1	200K	10	
Fusing cleaning kit	MX-230CR	Lower oil roller Lower CL roller Lower CL roller bearing Lower CL scraper	x 1 x 1 x 2 x 1	100K	10	
Primary transfer belt kit	MX-230B1	Primary transfer belt AR	x 1	100K	10	
Primary transfer blade kit	MX-230TL	Primary transfer blade AR	x 1	100K	10	
PTC kit	MX-230CU	PTC unit	x 1	100K	10	
Secondary transfer belt kit	MX-230B2	Secondary transfer belt D3	x 1	300K	10	
PS paper dust removing unit	MX-230PD	PS paper dust removing unit	x 1	100K	10	
Filter kit	MX-C31FL	Ozone filter	x 1	100K	10	
Toner collection container	MX-230HB	Toner collection container (with LSU cleaner x 2)	x 1	50K	5	5% coverage for each color; 25% color ratio

Item	Model name	Content	Life	Quantity in collective package	Remarks
Main charger kit	MX-230MK	Main charger unit x 1 Cleaning gum AS AR x 1 Cleaning blade AR x 1	Black: 100K Color: 60K	10	
Staple cartridge	MX-SCX1	Staple cartridge x 3	5000 times x 3	20	For MX-FN17
Finish stamp cartridge	AR-SV1	Finish stamp cartridge x 2	—	20	
Primary transfer belt unit	MX-230U1	Primary transfer belt unit (For servicing rotation) x 1	—	1	
Secondary transfer belt unit	MX-230U2	Secondary transfer belt unit (For servicing rotation) x 1	—	1	
Fusing unit	MX-230FU	Fusing unit (For servicing rotation: Heater lamp 230V) x 1	—	1	

### Note

When shipping, the parts are packed in the unit of 10 sets. In the market, however, they are treated in the unit of 1 set.

Model name: Composed of the parts of 1 set

### Note

The numbers in the column of "Quantity in collective package" in the above list indicate the quantities for one package shipped from the factory. Since, however, the products are treated as one piece or one set, their model names and necessary quantities must be specified when ordering. Pay attention to that.

## D. 31cpm(G) machine

### (1) North America, Middle America, South America

Item	Model name	Content	Life	Quantity in collective package	Remarks
Fusing belt kit	MX-360FB	Fusing belt x 1 Fuser belt guide collar x 2	200K	10	
Pressure roller kit	MX-230LH	Fusing roller x 1 Pressure roller x 1	200K	10	
Fusing cleaning kit	MX-260CR	Lower oil roller x 1 Lower CL roller x 1 Lower CL roller bearing x 2 Lower CL scraper x 1	100K	10	
Primary transfer belt kit	MX-230B1	Primary transfer belt AR x 1	100K	10	
Primary transfer blade kit	MX-230TL	Primary transfer blade AR x 1	100K	10	
PTC kit	MX-230CU	PTC unit x 1	100K	10	
Secondary transfer belt kit	MX-230B2	Secondary transfer belt D3 x 1	300K	10	
PS paper dust removing unit	MX-230PD	PS paper dust removing unit x 1	100K	10	
Filter kit	MX-C31FL	Ozone filter x 1	100K	10	
Main charger kit	MX-360MK	Main charger unit x 1 Cleaning gum AS AR x 1 Cleaning blade AR x 1	Black: 100K Color: 60K	10	
Staple cartridge	MX-SCX1	Staple cartridge x 3	5000 times x 3	20	For inner finisher (MX-FN17)
Finish stamp cartridge	AR-SV1	Finish stamp cartridge x 2	—	20	
Toner collection container	MX-230HB	Toner collection container (with LSU cleaner x 2) x 1	50K	5	5% coverage for each color; 25% color ratio
Primary transfer belt unit	MX-230U1	Primary transfer belt unit (For servicing rotation) x 1	—	1	
Secondary transfer belt unit	MX-230U2	Secondary transfer belt unit (For servicing rotation) x 1	—	1	
Fusing unit	MX-260FU1	Fusing unit (For servicing rotation: Heater lamp 120V) x 1	—	1	

### Note

When shipping, the parts are packed in the unit of 10 sets. In the market, however, they are treated in the unit of 1 set.

Model name: Composed of the parts of 1 set

### (2) Europe, Eastern Europe, Russia, Australia, New Zealand

Item	Model name	Content	Life	Quantity in collective package	Remarks
Fusing belt kit	MX-360FB	Fusing belt x 1 Fuser belt guide collar x 2	200K	10	
Pressure roller kit	MX-230LH	Fusing roller x 1 Pressure roller x 1	200K	10	



Item	Model name	Content	Life	Quantity in collective package	Remarks
Fusing cleaning kit	MX-230CR	Lower oil roller x 1 Lower CL roller x 1 Lower CL roller bearing x 2 Lower CL scraper x 1	100K	10	
Primary transfer belt kit	MX-230B1	Primary transfer belt AR x 1	100K	10	
Primary transfer blade kit	MX-230TL	Primary transfer blade AR x 1	100K	10	
PTC kit	MX-230CU	PTC unit x 1	100K	10	
Secondary transfer belt kit	MX-230B2	Secondary transfer belt D3 x 1	300K	10	
PS paper dust removing unit	MX-230PD	PS paper dust removing unit x 1	100K	10	
Filter kit	MX-C31FL	Ozone filter x 1	100K	10	
Toner collection container	MX-230HB	Toner collection container (with LSU cleaner x 2) x 1	50K	5	5% coverage for each color; 25% color ratio
Main charger kit	MX-230MK	Main charger unit x 1 Cleaning gum AS AR x 1 Cleaning blade AR x 1	Black: 100K Color: 60K	10	
Staple cartridge	MX-SCX1	Staple cartridge x 3	5000 times x 3	20	For inner finisher (MX-FN17)
Finish stamp cartridge	AR-SV1	Finish stamp cartridge x 2	—	20	
Primary transfer belt unit	MX-230U1	Primary transfer belt unit (For servicing rotation) x 1	—	1	
Secondary transfer belt unit	MX-230U2	Secondary transfer belt unit (For servicing rotation) x 1	—	1	
Fusing unit	MX-260FU	Fusing unit (For servicing rotation: Heater lamp 230V) x 1	—	1	
Fusing unit	MX-260FU2	Fusing unit (For servicing rotation: Heater lamp 110V) x 1	—	1	

### Note

When shipping, the parts are packed in the unit of 10 sets. In the market, however, they are treated in the unit of 1 set.  
Model name: Composed of the parts of 1 set

### (3) Asia, Middle East

Item	Model name	Content	Life	Quantity in collective package	Remarks
Fusing belt kit	MX-360FB	Fusing belt x 1 Fuser belt guide collar x 2	200K	10	
Pressure roller kit	MX-230LH	Fusing roller x 1 Pressure roller x 1	200K	10	
Fusing cleaning kit	MX-230CR	Lower oil roller x 1 Lower CL roller x 1 Lower CL roller bearing x 2 Lower CL scraper x 1	100K	10	
Primary transfer belt kit	MX-230B1	Primary transfer belt AR x 1	100K	10	
Primary transfer blade kit	MX-230TL	Primary transfer blade AR x 1	100K	10	
PTC kit	MX-230CU	PTC unit x 1	100K	10	
Secondary transfer belt kit	MX-230B2	Secondary transfer belt D3 x 1	300K	10	
PS paper dust removing unit	MX-230PD	PS paper dust removing unit x 1	100K	10	
Filter kit	MX-C31FL	Ozone filter x 1	100K	10	
Toner collection container	MX-230HB	Toner collection container (with LSU cleaner x 2) x 1	50K	5	5% coverage for each color; 25% color ratio
Main charger kit	MX-230MK	Main charger unit x 1 Cleaning gum AS AR x 1 Cleaning blade AR x 1	Black: 100K Color: 60K	10	
Staple cartridge	MX-SCX1	Staple cartridge x 3	5000 times x 3	20	For inner finisher (MX-FN17)
Finish stamp cartridge	AR-SV1	Finish stamp cartridge x 2	—	20	
Primary transfer belt unit	MX-230U1	Primary transfer belt unit (For servicing rotation) x 1	—	1	
Secondary transfer belt unit	MX-230U2	Secondary transfer belt unit (For servicing rotation) x 1	—	1	
Fusing unit	MX-260FU	Fusing unit (For servicing rotation: Heater lamp 230V) x 1	—	1	

### Note

When shipping, the parts are packed in the unit of 10 sets. In the market, however, they are treated in the unit of 1 set.  
Model name: Composed of the parts of 1 set

#### (4) Hong Kong

Item	Model name	Content	Life	Quantity in collective package	Remarks
Fusing belt kit	MX-360FB	Fusing belt x 1 Fuser belt guide collar x 2	200K	10	
Pressure roller kit	MX-230LH	Fusing roller x 1 Pressure roller x 1	200K	10	
Fusing cleaning kit	MX-230CR	Lower oil roller x 1 Lower CL roller x 1 Lower CL roller bearing x 2 Lower CL scraper x 1	100K	10	
Primary transfer belt kit	MX-230B1	Primary transfer belt AR x 1	100K	10	
Primary transfer blade kit	MX-230TL	Primary transfer blade AR x 1	100K	10	
PTC kit	MX-230CU	PTC unit x 1	100K	10	
Secondary transfer belt kit	MX-230B2	Secondary transfer belt D3 x 1	300K	10	
PS paper dust removing unit	MX-230PD	PS paper dust removing unit x 1	100K	10	
Filter kit	MX-C31FL	Ozone filter x 1	100K	10	
Toner collection container	MX-230HB	Toner collection container (with LSU cleaner x 2) x 1	50K	5	5% coverage for each color; 25% color ratio
Main charger kit	MX-230MK	Main charger unit x 1 Cleaning gum AS AR x 1 Cleaning blade AR x 1	Black: 100K Color: 60K	10	
Staple cartridge	MX-SCX1	Staple cartridge x 3	5000 times x 3	20	For inner finisher (MX-FN17)
Finish stamp cartridge	AR-SV1	Finish stamp cartridge x 2	—	20	
Primary transfer belt unit	MX-230U1	Primary transfer belt unit (For servicing rotation) x 1	—	1	
Secondary transfer belt unit	MX-230U2	Secondary transfer belt unit (For servicing rotation) x 1	—	1	
Fusing unit	MX-260FU	Fusing unit (For servicing rotation: Heater lamp 230V) x 1	—	1	

#### Note

When shipping, the parts are packed in the unit of 10 sets. In the market, however, they are treated in the unit of 1 set.  
Model name: Composed of the parts of 1 set

#### Note

The numbers in the column of "Quantity in collective package" in the above list indicate the quantities for one package shipped from the factory. Since, however, the products are treated as one piece or one set, their model names and necessary quantities must be specified when ordering. Pay attention to that.

### E. 26cpm/31cpm(A) machine

#### (1) North America, Middle America, South America

Item	Model name	Content	Life	Quantity in collective package	Remarks
Fusing belt kit	MX-360FB	Fusing belt x 1 Fuser belt guide collar x 2	200K	10	
Pressure roller kit	MX-230LH	Fusing roller x 1 Pressure roller x 1	200K	10	
Fusing cleaning kit	MX-230CR	Lower oil roller x 1 Lower CL roller x 1 Lower CL roller bearing x 2 Lower CL scraper x 1	100K	10	
Primary transfer belt kit	MX-230B1	Primary transfer belt AR x 1	100K	10	
Primary transfer blade kit	MX-230TL	Primary transfer blade AR x 1	100K	10	
PTC kit	MX-230CU	PTC unit x 1	100K	10	
Secondary transfer belt kit	MX-230B2	Secondary transfer belt D3 x 1	300K	10	
PS paper dust removing unit	MX-230PD	PS paper dust removing unit x 1	100K	10	
Filter kit	MX-C31FL	Ozone filter x 1	100K	10	
Toner collection container	MX-230HB	Toner collection container (with LSU cleaner x 2) x 1	50K	5	5% coverage for each color; 25% color ratio
Main charger kit	MX-360MK	Main charger unit x 1 Cleaning gum AS AR x 1 Cleaning blade AR x 1	Black: 100K Color: 60K	10	
Staple cartridge	AR-SC3	Staple cartridge x 3	2000 times x 3	40	For saddle finisher (MX-FN10)
Staple cartridge	MX-SCX1	Staple cartridge x 3	5000 times x 3	20	For saddle finisher (MX-FN10) and inner finisher (MX-FN17)
Finish stamp cartridge	AR-SV1	Finish stamp cartridge x 2	—	20	

Item	Model name	Content	Life	Quantity in collective package	Remarks
Primary transfer belt unit	MX-230U1	Primary transfer belt unit (For servicing rotation) x 1	—	1	
Secondary transfer belt unit	MX-230U2	Secondary transfer belt unit (For servicing rotation) x 1	—	1	
Fusing unit	MX-260FU1	Fusing unit (For servicing rotation: Heater lamp 120V) x 1	—	1	
Fusing unit	MX-260FU	Fusing unit (For servicing rotation: Heater lamp 230V) x 1	—	1	

### Note

When shipping, the parts are packed in the unit of 10 sets. In the market, however, they are treated in the unit of 1 set.

Model name: Composed of the parts of 1 set

### (2) Europe, Eastern Europe, Russia, Australia, New Zealand

Item	Model name	Content	Life	Quantity in collective package	Remarks
Fusing belt kit	MX-360FB	Fusing belt x 1 Fuser belt guide collar x 2	200K	10	
Pressure roller kit	MX-230LH	Fusing roller x 1 Pressure roller x 1	200K	10	
Fusing cleaning kit	MX-230CR	Lower oil roller x 1 Lower CL roller x 1 Lower CL roller bearing x 2 Lower CL scraper x 1	100K	10	
Primary transfer belt kit	MX-230B1	Primary transfer belt AR x 1	100K	10	
Primary transfer blade kit	MX-230TL	Primary transfer blade AR x 1	100K	10	
PTC kit	MX-230CU	PTC unit x 1	100K	10	
Secondary transfer belt kit	MX-230B2	Secondary transfer belt D3 x 1	300K	10	
PS paper dust removing unit	MX-230PD	PS paper dust removing unit x 1	100K	10	
Filter kit	MX-C31FL	Ozone filter x 1	100K	10	
Toner collection container	MX-230HB	Toner collection container (with LSU cleaner x 2) x 1	50K	5	5% coverage for each color; 25% color ratio
Main charger kit	MX-230MK	Main charger unit x 1 Cleaning gum AS AR x 1 Cleaning blade AR x 1	Black: 100K Color: 60K	10	
Staple cartridge	AR-SC3	Staple cartridge x 3	2000 times x 3	40	For MX-FN10 (saddle staple)
Staple cartridge	MX-SCX1	Staple cartridge x 3	5000 times x 3	20	For MX-FN10/FN17
Finish stamp cartridge	AR-SV1	Finish stamp cartridge x 2	—	20	
Primary transfer belt unit	MX-230U1	Primary transfer belt unit (For servicing rotation) x 1	—	1	
Secondary transfer belt unit	MX-230U2	Secondary transfer belt unit (For servicing rotation) x 1	—	1	
Fusing unit	MX-260FU	Fusing unit (For servicing rotation: Heater lamp 230V) x 1	—	1	
Fusing unit	MX-260FU2	Fusing unit (For servicing rotation: Heater lamp 110V) x 1	—	1	

### Note

When shipping, the parts are packed in the unit of 10 sets. In the market, however, they are treated in the unit of 1 set.

Model name: Composed of the parts of 1 set

### (3) Asia, Middle East

Item	Model name	Content	Life	Quantity in collective package	Remarks
Fusing belt kit	MX-360FB	Fusing belt x 1 Fuser belt guide collar x 2	200K	10	
Pressure roller kit	MX-230LH	Fusing roller x 1 Pressure roller x 1	200K	10	
Fusing cleaning kit	MX-230CR	Lower oil roller x 1 Lower CL roller x 1 Lower CL roller bearing x 2 Lower CL scraper x 1	100K	10	
Primary transfer belt kit	MX-230B1	Primary transfer belt AR x 1	100K	10	
Primary transfer blade kit	MX-230TL	Primary transfer blade AR x 1	100K	10	
PTC kit	MX-230CU	PTC unit x 1	100K	10	
Secondary transfer belt kit	MX-230B2	Secondary transfer belt D3 x 1	300K	10	
PS paper dust removing unit	MX-230PD	PS paper dust removing unit x 1	100K	10	
Filter kit	MX-C31FL	Ozone filter x 1	100K	10	
Toner collection container	MX-230HB	Toner collection container (with LSU cleaner x 2) x 1	50K	5	5% coverage for each color; 25% color ratio

Item	Model name	Content	Life	Quantity in collective package	Remarks
Main charger kit	MX-230MK	Main charger unit x 1 Cleaning gum AS AR x 1 Cleaning blade AR x 1	Black: 100K Color: 60K	10	
Staple cartridge	AR-SC3	Staple cartridge x 3	2000 times x 3	40	For MX-FN10 (saddle staple)
Staple cartridge	MX-SCX1	Staple cartridge x 3	5000 times x 3	20	For MX-FN10/FN17
Finish stamp cartridge	AR-SV1	Finish stamp cartridge x 2	—	20	
Primary transfer belt unit	MX-230U1	Primary transfer belt unit (For servicing rotation) x 1	—	1	
Secondary transfer belt unit	MX-230U2	Secondary transfer belt unit (For servicing rotation) x 1	—	1	
Fusing unit	MX-260FU1	Fusing unit (For servicing rotation: Heater lamp 120V) x 1	—	1	
Fusing unit	MX-260FU	Fusing unit (For servicing rotation: Heater lamp 230V) x 1	—	1	

#### Note

When shipping, the parts are packed in the unit of 10 sets. In the market, however, they are treated in the unit of 1 set.  
Model name: Composed of the parts of 1 set

#### (4) Hong Kong

Item	Model name	Content	Life	Quantity in collective package	Remarks
Fusing belt kit	MX-360FB	Fusing belt x 1 Fuser belt guide collar x 2	200K	10	
Pressure roller kit	MX-230LH	Fusing roller x 1 Pressure roller x 1	200K	10	
Fusing cleaning kit	MX-230CR	Lower oil roller x 1 Lower CL roller x 1 Lower CL roller bearing x 2 Lower CL scraper x 1	100K	10	
Primary transfer belt kit	MX-230B1	Primary transfer belt AR x 1	100K	10	
Primary transfer blade kit	MX-230TL	Primary transfer blade AR x 1	100K	10	
PTC kit	MX-230CU	PTC unit x 1	100K	10	
Secondary transfer belt kit	MX-230B2	Secondary transfer belt D3 x 1	300K	10	
PS paper dust removing unit	MX-230PD	PS paper dust removing unit x 1	100K	10	
Filter kit	MX-C31FL	Ozone filter x 1	100K	10	
Toner collection container	MX-230HB	Toner collection container (with LSU cleaner x 2) x 1	50K	5	5% coverage for each color; 25% color ratio
Main charger kit	MX-230MK	Main charger unit x 1 Cleaning gum AS AR x 1 Cleaning blade AR x 1	Black: 100K Color: 60K	10	
Staple cartridge	AR-SC3	Staple cartridge x 3	2000 times x 3	40	For MX-FN10 (saddle staple)
Staple cartridge	MX-SCX1	Staple cartridge x 3	5000 times x 3	20	For MX-FN10/FN17
Finish stamp cartridge	AR-SV1	Finish stamp cartridge x 2	—	20	
Primary transfer belt unit	MX-230U1	Primary transfer belt unit (For servicing rotation) x 1	—	1	
Secondary transfer belt unit	MX-230U2	Secondary transfer belt unit (For servicing rotation) x 1	—	1	
Fusing unit	MX-260FU	Fusing unit (For servicing rotation: Heater lamp 230V) x 1	—	1	

#### Note

When shipping, the parts are packed in the unit of 10 sets. In the market, however, they are treated in the unit of 1 set.  
Model name: Composed of the parts of 1 set

#### Note

The numbers in the column of "Quantity in collective package" in the above list indicate the quantities for one package shipped from the factory. Since, however, the products are treated as one piece or one set, their model names and necessary quantities must be specified when ordering. Pay attention to that.

## F. 36cpm machine

### (1) North America, Middle America, South America

Item	Model name	Content	Life	Quantity in collective package	Remarks
Fusing belt kit	MX-360FB	Fusing belt x 1 Fuser belt guide collar x 2	240K	10	
Pressure roller kit	MX-230LH	Fusing roller x 1 Pressure roller x 1	240K	10	
Web cleaning kit	MX-360WB	Web roller x 1 Web guide shaft x 2 Web pressure roller x 1 Web pressure roller bearing x 2	120K	10	
Primary transfer belt kit	MX-230B1	Primary transfer belt AR x 1	120K	10	
Primary transfer blade kit	MX-230TL	Primary transfer blade AR x 1	120K	10	
PTC kit	MX-230CU	PTC unit x 1	120K	10	
Secondary transfer belt kit	MX-230B2	Secondary transfer belt D3 x 1	360K	10	
PS paper dust removing unit	MX-230PD	PS paper dust removing unit x 1	120K	10	
Filter kit	MX-C31FL	Ozone filter x 1	120K	10	
Main charger kit	MX-360MK	Main charger unit x 1 Cleaning gum AS AR x 1 Cleaning blade AR x 1	Black: 120K Color: 70K	10	
Staple cartridge	AR-SC3	Staple cartridge x 3	2000 times x 3	40	For saddle finisher (MX-FN10)
Staple cartridge	MX-SCX1	Staple cartridge x 3	5000 times x 3	20	For saddle finisher (MX-FN10) and inner finisher (MX-FN17)
Finish stamp cartridge	AR-SV1	Finish stamp cartridge x 2	—	20	
Toner collection container	MX-230HB	Toner collection container (with LSU cleaner x 2) x 1	50K	5	5% coverage for each color; 25% color ratio
Primary transfer belt unit	MX-230U1	Primary transfer belt unit (For servicing rotation) x 1	—	1	
Secondary transfer belt unit	MX-230U2	Secondary transfer belt unit (For servicing rotation) x 1	—	1	
Fusing unit	MX-360FU1	Fusing unit (For servicing rotation: Heater lamp 120V) x 1	—	1	

#### Note

When shipping, the parts are packed in the unit of 10 sets. In the market, however, they are treated in the unit of 1 set.

Model name: Composed of the parts of 1 set

### (2) Europe, Eastern Europe, Russia, Australia, New Zealand

Item	Model name	Content	Life	Quantity in collective package	Remarks
Fusing belt kit	MX-360FB	Fusing belt x 1 Fuser belt guide collar x 2	240K	10	
Pressure roller kit	MX-230LH	Fusing roller x 1 Pressure roller x 1	240K	10	
Web cleaning kit	MX-360WB	Web roller x 1 Web guide shaft x 2 Web pressure roller x 1 Web pressure roller bearing x 2	120K	10	
Primary transfer belt kit	MX-230B1	Primary transfer belt AR x 1	120K	10	
Primary transfer blade kit	MX-230TL	Primary transfer blade AR x 1	120K	10	
PTC kit	MX-230CU	PTC unit x 1	120K	10	
Secondary transfer belt kit	MX-230B2	Secondary transfer belt D3 x 1	360K	10	
PS paper dust removing unit	MX-230PD	PS paper dust removing unit x 1	120K	10	
Filter kit	MX-C31FL	Ozone filter x 1	120K	10	
Toner collection container	MX-230HB	Toner collection container (with LSU cleaner x 2) x 1	50K	5	5% coverage for each color; 25% color ratio
Main charger kit	MX-230MK	Main charger unit x 1 Cleaning gum AS AR x 1 Cleaning blade AR x 1	Black: 120K Color: 70K	10	
Staple cartridge	AR-SC3	Staple cartridge x 3	2000 times x 3	40	For MX-FN10 (saddle staple)
Staple cartridge	MX-SCX1	Staple cartridge x 3	5000 times x 3	20	For MX-FN10/FN17
Finish stamp cartridge	AR-SV1	Finish stamp cartridge x 2	—	20	
Primary transfer belt unit	MX-230U1	Primary transfer belt unit (For servicing rotation) x 1	—	1	
Secondary transfer belt unit	MX-230U2	Secondary transfer belt unit (For servicing rotation) x 1	—	1	
Fusing unit	MX-360FU	Fusing unit (For servicing rotation: Heater lamp 230V) x 1	—	1	

**Note**

When shipping, the parts are packed in the unit of 10 sets. In the market, however, they are treated in the unit of 1 set.

Model name: Composed of the parts of 1 set

**(3) Asia, Middle East**

Item	Model name	Content	Life	Quantity in collective package	Remarks
Fusing belt kit	MX-360FB	Fusing belt x 1 Fuser belt guide collar x 2	240K	10	
Pressure roller kit	MX-230LH	Fusing roller x 1 Pressure roller x 1	240K	10	
Web cleaning kit	MX-360WB	Web roller x 1 Web guide shaft x 2 Web pressure roller x 1 Web pressure roller bearing x 2	120K	10	
Primary transfer belt kit	MX-230B1	Primary transfer belt AR x 1	120K	10	
Primary transfer blade kit	MX-230TL	Primary transfer blade AR x 1	120K	10	
PTC kit	MX-230CU	PTC unit x 1	120K	10	
Secondary transfer belt kit	MX-230B2	Secondary transfer belt D3 x 1	360K	10	
PS paper dust removing unit	MX-230PD	PS paper dust removing unit x 1	120K	10	
Filter kit	MX-C31FL	Ozone filter x 1	120K	10	
Toner collection container	MX-230HB	Toner collection container (with LSU cleaner x 2) x 1	50K	5	5% coverage for each color; 25% color ratio
Main charger kit	MX-230MK	Main charger unit x 1 Cleaning gum AS AR x 1 Cleaning blade AR x 1	Black: 120K Color: 70K	10	
Staple cartridge	AR-SC3	Staple cartridge x 3	2000 times x 3	40	For MX-FN10 (saddle staple)
Staple cartridge	MX-SCX1	Staple cartridge x 3	5000 times x 3	20	For MX-FN10/FN17
Finish stamp cartridge	AR-SV1	Finish stamp cartridge x 2	—	20	
Primary transfer belt unit	MX-230U1	Primary transfer belt unit (For servicing rotation) x 1	—	1	
Secondary transfer belt unit	MX-230U2	Secondary transfer belt unit (For servicing rotation) x 1	—	1	
Fusing unit	MX-360FU	Fusing unit (For servicing rotation: Heater lamp 230V) x 1	—	1	

**Note**

When shipping, the parts are packed in the unit of 10 sets. In the market, however, they are treated in the unit of 1 set.

Model name: Composed of the parts of 1 set

**(4) Hong Kong**

Item	Model name	Content	Life	Quantity in collective package	Remarks
Fusing belt kit	MX-360FB	Fusing belt x 1 Fuser belt guide collar x 2	240K	10	
Pressure roller kit	MX-230LH	Fusing roller x 1 Pressure roller x 1	240K	10	
Web cleaning kit	MX-360WB	Web roller x 1 Web guide shaft x 2 Web pressure roller x 1 Web pressure roller bearing x 2	120K	10	
Primary transfer belt kit	MX-230B1	Primary transfer belt AR x 1	120K	10	
Primary transfer blade kit	MX-230TL	Primary transfer blade AR x 1	120K	10	
PTC kit	MX-230CU	PTC unit x 1	120K	10	
Secondary transfer belt kit	MX-230B2	Secondary transfer belt D3 x 1	360K	10	
PS paper dust removing unit	MX-230PD	PS paper dust removing unit x 1	120K	10	
Filter kit	MX-C31FL	Ozone filter x 1	120K	10	
Toner collection container	MX-230HB	Toner collection container (with LSU cleaner x 2) x 1	50K	5	5% coverage for each color; 25% color ratio
Main charger kit	MX-230MK	Main charger unit x 1 Cleaning gum AS AR x 1 Cleaning blade AR x 1	Black: 120K Color: 70K	10	
Staple cartridge	AR-SC3	Staple cartridge x 3	2000 times x 3	40	For MX-FN10 (saddle staple)
Staple cartridge	MX-SCX1	Staple cartridge x 3	5000 times x 3	20	For MX-FN10/FN17
Finish stamp cartridge	AR-SV1	Finish stamp cartridge x 2	—	20	

Item	Model name	Content	Life	Quantity in collective package	Remarks
Primary transfer belt unit	MX-230U1	Primary transfer belt unit (For servicing rotation) x 1	—	1	
Secondary transfer belt unit	MX-230U2	Secondary transfer belt unit (For servicing rotation) x 1	—	1	
Fusing unit	MX-360FU	Fusing unit (For servicing rotation: Heater lamp 230V) x 1	—	1	

**Note**

When shipping, the parts are packed in the unit of 10 sets. In the market, however, they are treated in the unit of 1 set.

Model name: Composed of the parts of 1 set

**Note**

The numbers in the column of "Quantity in collective package" in the above list indicate the quantities for one package shipped from the factory. Since, however, the products are treated as one piece or one set, their model names and necessary quantities must be specified when ordering. Pay attention to that.

### 3. Definition of developer/drum life end

When the developer/drum counter reaches the specified count.

When the developer/drum rpm reaches the specified count.

When either of the above reach the specified count, it is judged as life end.

In an actual case, the ratio of monochrome output and color output may differ greatly.

When data of mixed documents (monochrome and color) are output, monochrome document data may be output in the color mode in order to prevent against fall in the job efficiency. (ACS auto color selection).

In addition, when correction or warm-up operation is performed as well as output operation, the developer and the drum rotates.

Therefore, the developer/drum consuming level cannot be determined only by the copy/print quantity. When, therefore, the rpm reaches the specified amount, it is judged as life end.

To check the developer/drum life, use SIM22-13.

#### A. 18cpm machine

	Developer/drum counter		Developer/drum rpm	
	B/W	Full color	B/W	Full color
Developer/drum	80K	50K	840K rotations	840K rotations

Kind of multi	Black drum	Color drum
Single multi	58000	38000
2 sheets multi	80000	50000

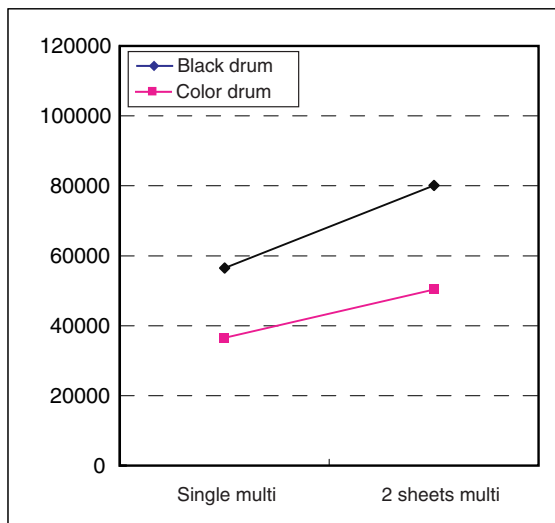

#### B. 20cpm machine

	Developer/drum counter		Developer/drum rpm	
	B/W	Full color	B/W	Full color
Developer/drum	100K	60K	840K rotations	840K rotations

Kind of multi	Black drum	Color drum
Single multi	64000	40000
2 sheets multi	100000	60000

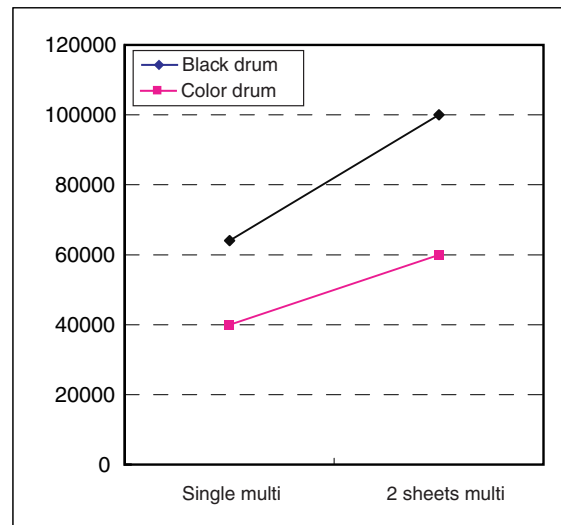

### C. 23cpm machine

	Developer/drum counter		Developer/drum rpm	
	B/W	Full color	B/W	Full color
Developer/drum	100K	60K	840K rotations	840K rotations

Kind of multi	Black drum	Color drum
Single multi	64000	40000
2 sheets multi	84000	52000
3 sheets multi	100000	60000

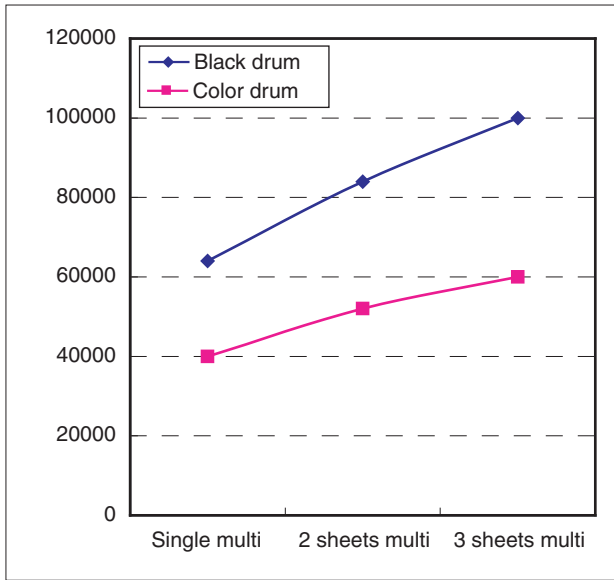

### D. 26cpm machine

	Developer/drum counter		Developer/drum rpm	
	B/W	Full color	B/W	Full color
Developer/drum	100K	60K	840K rotations	840K rotations

Kind of multi	Black drum	Color drum
Single multi	64000	40000
2 sheets multi	84000	52000
3 sheets multi	100000	60000

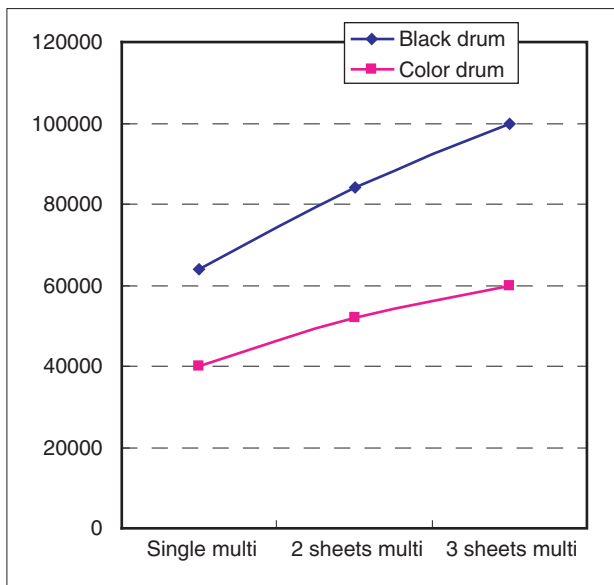

### E. 31cpm machine

	Developer/drum counter		Developer/drum rpm	
	B/W	Full color	B/W	Full color
Developer/drum	100K	60K	840K rotations	840K rotations

Kind of multi	Black drum	Color drum
Single multi	64000	40000
2 sheets multi	85000	53000
3 sheets multi	95000	58000
4 sheets multi	100000	60000

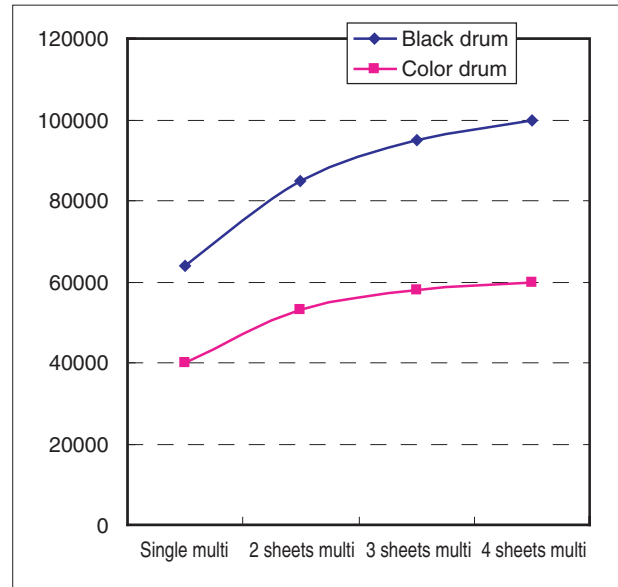

### F. 36cpm machine

	Developer/drum counter		Developer/drum rpm	
	B/W	Full color	B/W	Full color
Developer/drum	120K	70K	840K rotations	840K rotations

Kind of multi	Black drum	Color drum
Single multi	80000	50000
2 sheets multi	100000	60000
3 sheets multi	112000	66000
4 sheets multi	120000	70000

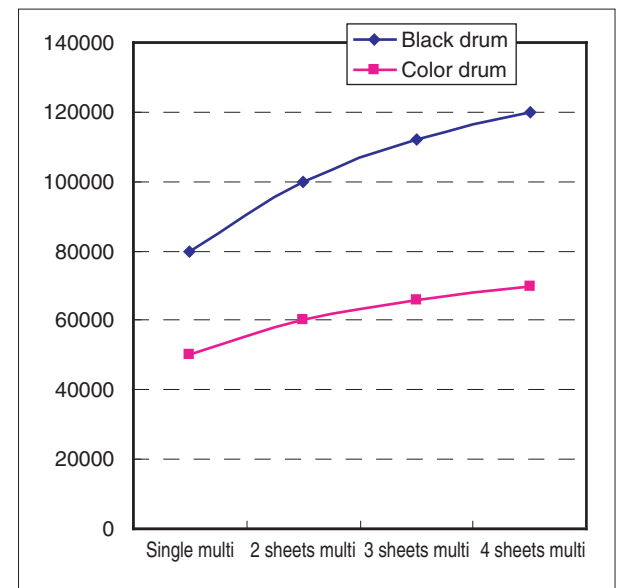



## 4. Production number identification

### A. OPC drum

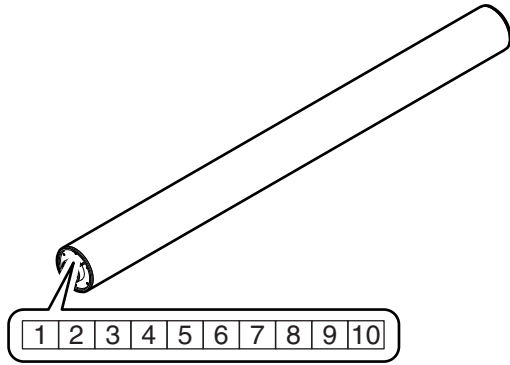

The lot number is comprised of 10 digits. Each digit indicates the content as follows.

The number is printed on the flange on the front side.

- 1: Number  
For this model, this digit is 2.
- 2: Alphabet  
Indicates the model conformity code.
- 3: Number  
Indicates the end digit of the production year.
- 4: Number or X, Y, Z  
Indicates the production month.  
X stands for October, Y November, and Z December.
- 5/6: Number  
Indicates the day of the production date.  
X stands for October, Y November, and Z December.
- 7: Number  
Indicates the day of the month of packing.  
X stands for October, Y November, and Z December.
- 8/9: Number  
Indicates the day of the packing date.
- 10: Alphabet  
Indicates the production factory.

### B. Developer

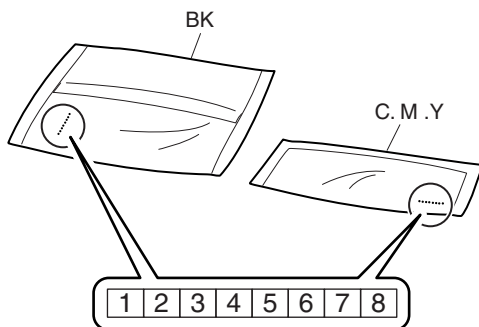

The lot number is 8 digits in length. Each digit indicates the content as follows.

The number is printed on the right under side of the back surface of the developer bag.

- 1: Alphabet  
Indicates the production factory.
- 2: Number  
Indicates the production year.
- 3/4: Number  
Indicates the production month.
- 5/6: Number  
Indicates the production day.
- 7: Hyphen
- 8: Number  
Indicates the production lot.

### C. Toner cartridge

The label indicating the management number is attached to the side of the toner cartridge.

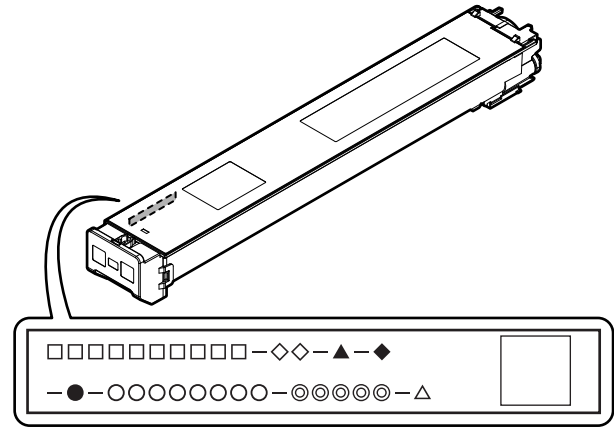

- : Unit code/Model name
- ◇: Color code (Black: BK /Cyan: CY /Magenta: MA /Yellow: YE)
- ▲: Destination
- ◆: Skating
- : Production place
- : Production date (YYYYMMDD)
- ◎: Serial number
- △: Version number

## 5. Environmental conditions

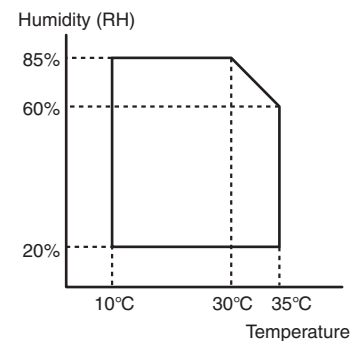

Standard environmental conditions	Temperature	20 – 25 °C
	Humidity	65 ± 5 %RH
Usage environmental conditions	Temperature	10 – 35 °C
	Humidity	20 – 85 %RH
Storage period	Toner/Developer: 24 months from the manufactured month (Production lot) under unsealed state Drum: 36 months from the manufactured month under unsealed state	

### [3] EXTERNAL VIEW AND INTERNAL STRUCTURE

#### 1. External view

##### A. 18cpm/20cpm/23cpm/31cpm(G) machine

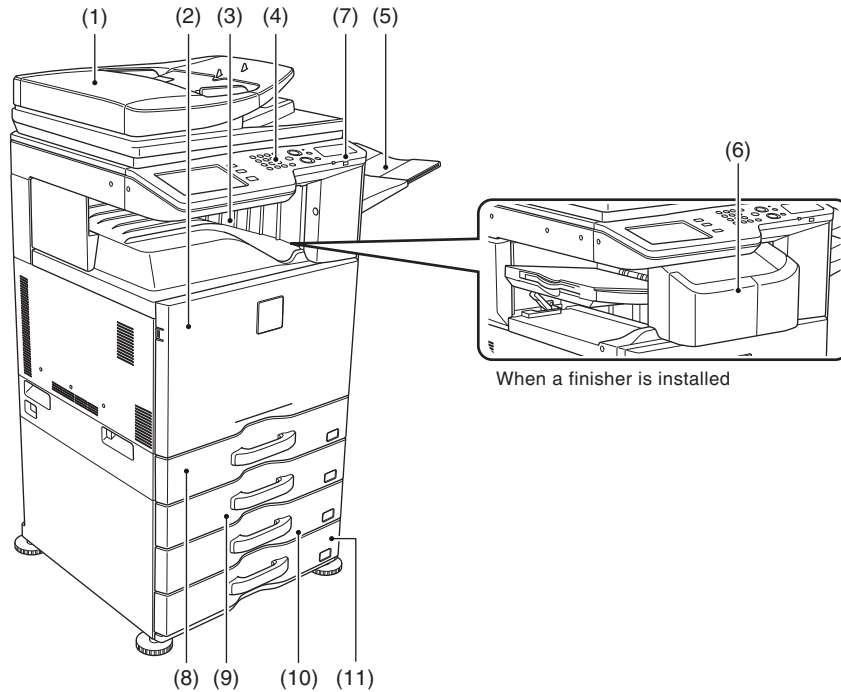

No.	Name	Function/Operation
1	Reversing single pass feeder	This automatically feeds and scans multiple originals. Both sides of 2-sided originals can be automatically scanned.
2	Front cover	Open this cover to switch the main power switch to "On" or "Off" or to replace a toner cartridge.
3	Output tray (center tray)	Output is delivered to this tray.
4	Operation panel	This is used to select functions and enter the number of copies.
5	Exit tray unit (right exit tray)*1, *2	When installed, output can be delivered to this tray.
6	Finisher*1, *2	This can be used to staple output. A punch module can also be installed to punch holes in output.
7	USB connector (A type)*2	Supports USB 2.0 (Hi-Speed). This is used to connect a USB device such as USB memory to the machine. For the USB cable, use a shielded cable.
8	Tray 1	This holds paper.
9	Tray 2 (when a paper drawer is installed)*	This holds paper.
10	Tray 3 (when a paper drawer is installed)*	This holds paper.
11	Tray 4 (when a paper drawer is installed)*	This holds paper.

\*1: Peripheral device.

\*2: 18cpm machine are not installed.

## B. 26cpm/36cpm/31cpm(A) machine

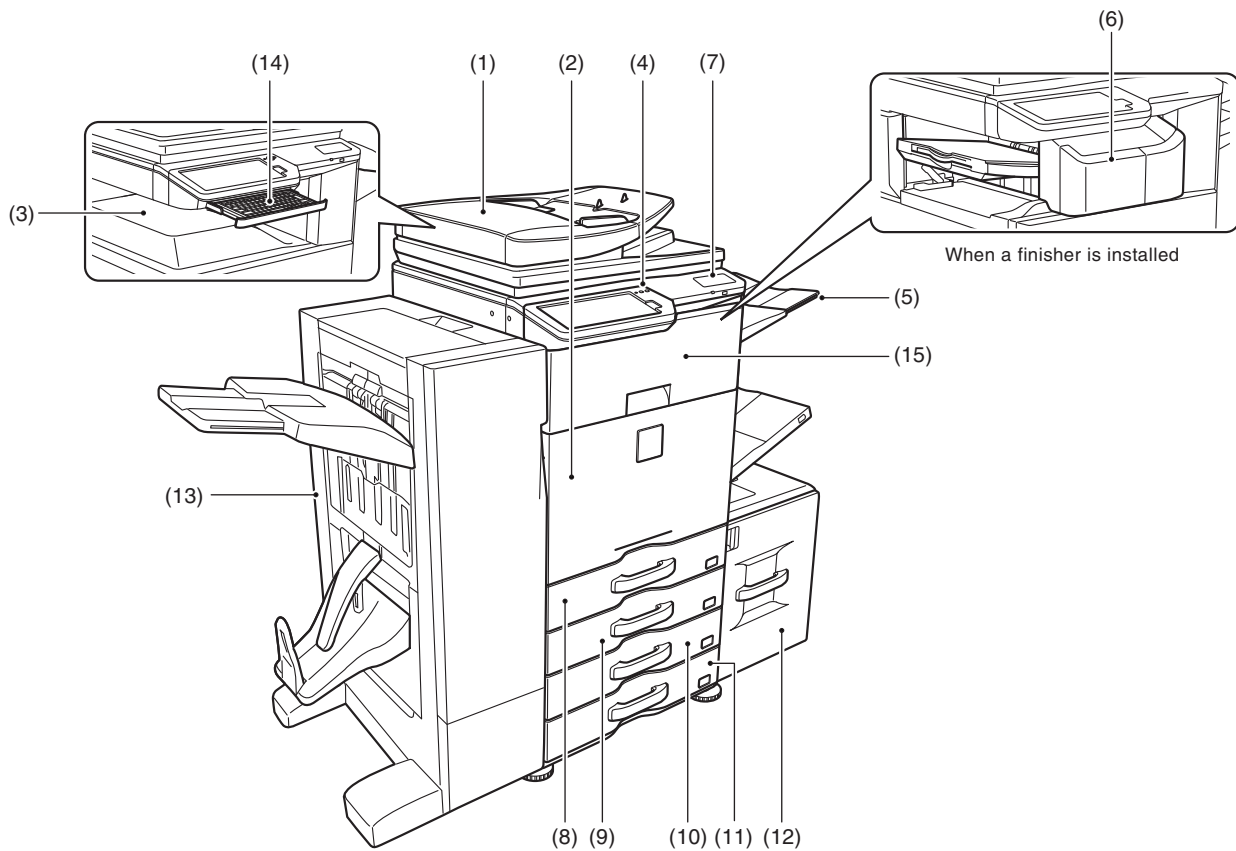

No.	Name	Function/Operation
1	Reversing single pass feeder	This automatically feeds and scans multiple originals. Both sides of 2-sided originals can be automatically scanned.
2	Front cover	Open this cover to switch the main power switch to "On" or "Off" or to replace a toner cartridge.
3	Output tray (center tray)	Output is delivered to this tray.
4	Operation panel	This is used to select functions and enter the number of copies.
5	Exit tray unit (right exit tray)*	When installed, output can be delivered to this tray.
6	Finisher*	This can be used to staple output. A punch module can also be installed to punch holes in output.
7	USB connector (A type)	Supports USB 2.0 (Hi-Speed). This is used to connect a USB device such as USB memory to the machine. For the USB cable, use a shielded cable.
8	Tray 1	This holds paper.
9	Tray 2 (when a paper drawer is installed)*	This holds paper.
10	Tray 3 (when a paper drawer is installed)*	This holds paper.
11	Tray 4 (when a paper drawer is installed)*	This holds paper.
12	Tray 5 (when a large capacity tray is installed)*	This holds paper.
13	Saddle stitch finisher*	This can be used to staple output. The saddle stitch function for folding and stapling output and the fold function for folding output in half are also available. A punch module can also be installed to punch holes in output.
14	Keyboard*	This is a keyboard that is incorporated into the machine. When not used, it can be stored under the operation panel.
15	Paper pass unit*	Transports paper to the finisher.

\* Peripheral device.

### C. Automatic document feeder and document glass

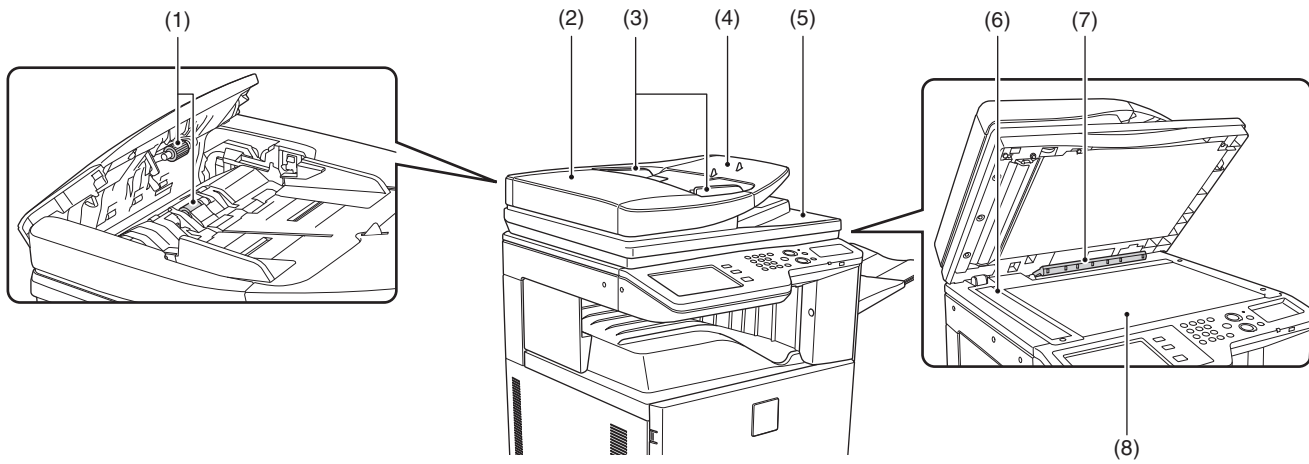

No.	Name	Function/Operation
1	Paper feed roller	This roller rotates to automatically feed the original.
2	Document feeding area cover	Open this cover to remove an original misfeed or clean the paper feed roller.
3	Original guides	These help ensure that the original is scanned correctly. Adjust the guides to the width of the original.
4	Document feeder tray	Place originals in this tray. 1-sided originals must be placed face up.
5	Original exit tray	Originals are delivered to this tray after scanning.
6	Scanning area	Originals placed in the document feeder tray are scanned here.
7	Original size detector	This detects the size of an original placed on the document glass.
8	Document glass	Use this to scan a book or other thick original that cannot be fed through the automatic document feeder.

## 2. Internal structure

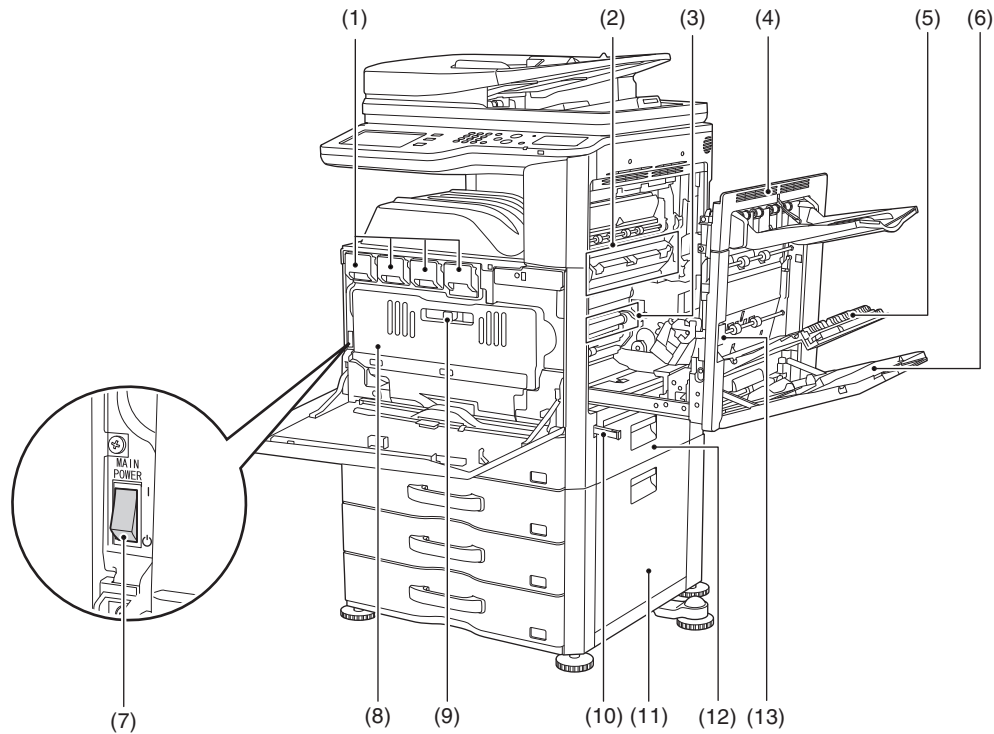

No.	Name	Function/Operation	Note
1	Toner cartridges	These contain toner for printing. When the toner runs out in a cartridge, the cartridge of the color that ran out must be replaced.	
2	Fusing unit	Heat is applied here to fuse the transferred image onto the paper.	<b>Important</b> The fusing unit is hot. Take care not to burn yourself when removing a paper misfeed.
3	Transfer belt	During full color printing, the toner images of each of the four colors on each of the photoconductive drums are combined together on the transfer belt. During black and white printing, only the black toner image is transferred onto the transfer belt.	Do not touch or damage the transfer belt. This may cause a defective image.
4	Right side cover	Open this cover to remove a misfeed.	
5	Paper reversing section cover	This is used when 2-sided printing is performed. Open this cover to remove a paper misfeed.	
6	Bypass tray	Use this tray to feed paper manually. When loading a large sheet of paper, be sure to pull out the bypass tray extension.	
7	Main power switch	This is used to power on the machine. When using the fax or Internet fax functions, keep this switch in the "on" position.	
8	Waste toner box	This collects excess toner that remains after printing.	
9	Waste toner box release lever	Move this lever when you need to release the waste toner box lock to replace the waste toner box or clean the laser unit.	
10	Handle	Pull this out and grasp it when moving the machine.	
11	Right cover of paper drawer (when a paper drawer is installed)	Open this to remove a paper misfeed in tray 2, tray 3 or tray 4.	
12	Paper tray right side cover	Open this to remove a paper misfeed in tray 1.	
13	Right side cover release lever	To remove a paper misfeed, pull and hold this lever up to open the right side cover.	

### 3. I/F connectors

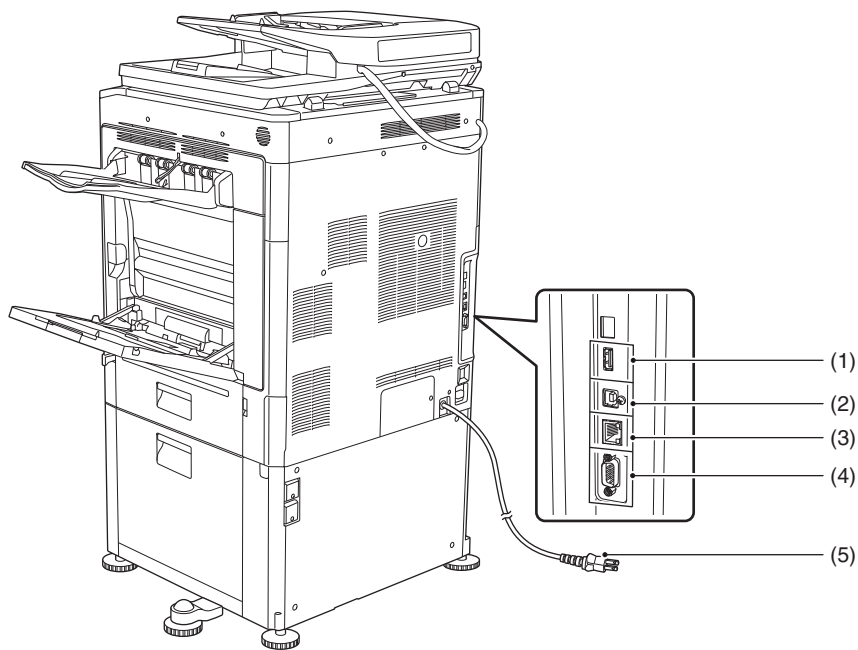

When the fax expansion kit is installed

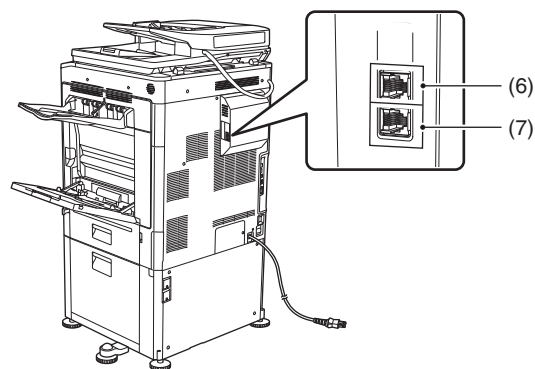

No.	Name	Function/Operation
1	USB connector (A type)	Supports USB 2.0 (Hi-Speed). This is used to connect a USB device such as USB memory to the machine.
2	USB connector (B type)	Supports USB 2.0 (Hi-Speed). A computer can be connected to this connector to use the machine as a printer. For the USB cable, use a shielded cable.
3	LAN connector	Connect the LAN cable to this connector when the machine is used on a network. For the LAN cable, use a shielded type cable.
4	Service-only connector	<b>Important</b> This connector is for use only by service technicians. Connecting a cable to this connector may cause the machine to malfunction. Important note for service technicians: The cable connected to the service connector must be less than 3 m (118") in length.
5	Power plug	
6	Extension phone socket	When the fax function of the machine is used, an extension phone can be connected to this socket.
7	Telephone line socket	When the fax function of the machine is used, the telephone line is connected to this socket.

## 4. Operation panel

### A. 18cpm/20cpm/23cpm/31cpm(G) machine

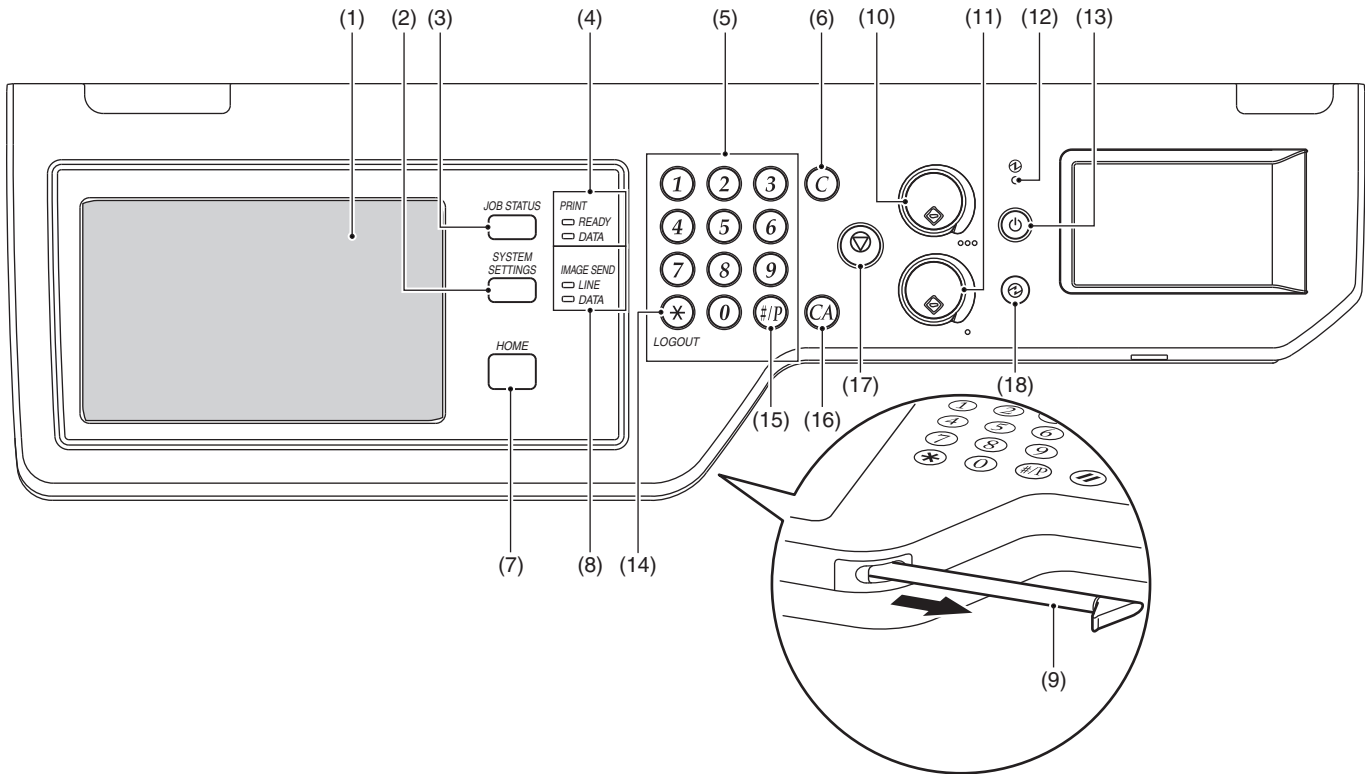

No.	Name	Function/Operation
1	Touch panel	Messages and keys appear in the touch panel display. Touch the displayed keys to perform a variety of operations. When a key is touched, a beep sounds and the selected item is highlighted. This provides confirmation as you perform an operation.
2	[SYSTEM SETTINGS] key	Press this key to display the system settings menu screen. The system settings are used to configure paper tray settings, store addresses for transmission operations, and adjust parameters to make the machine easier to use.
3	[JOB STATUS] key	Press this key to display the job status screen. The job status screen is used to check information on jobs and to cancel jobs.
4	PRINT mode indicators	<ul style="list-style-type: none"> <li>READY indicator Print jobs can be received when this indicator is lit.</li> <li>DATA indicator This blinks while print data is being received and lights steadily while printing is taking place.</li> </ul>
5	Numeric keys (10-key)	These are used to enter the number of copies, fax numbers, and other numerical values. These keys are also used to enter numeric value settings (except for the system settings).
6	[CLEAR] key (C)	Press this key to return the number of copies to "0".
7	[HOME] key	Touch this key to display the home screen. Frequently used settings can be registered in the home screen to enable quick and easy operation of the machine.
8	IMAGE SEND mode indicators	<ul style="list-style-type: none"> <li>LINE indicator This lights up during transmission or reception of a fax or Internet fax. This also lights during transmission of an image in scan mode.</li> <li>DATA indicator This blinks when a received fax or Internet fax cannot be printed because of a problem such as out of paper. This lights up when there is a transmission job that has not been sent.</li> </ul>
9	Stylus pen	This can be used to touch a key displayed on the touch panel.
10	[COLOR START] key (C)	Press this key to copy or scan an original in color. This key cannot be used for fax or Internet fax.
11	[BLACK & WHITE START] key (C)	Press this key to copy or scan an original in black and white. This key is also used to send a fax in fax mode.
12	Main power indicator	This lights up when the machine's main power switch is in the "on" position.
13	[POWER] key (⏻)	Use this key to turn the machine power on and off.
14	[LOGOUT] key (*)	Press this key to log out after you have logged in and used the machine. When using the fax function, this key can also be pressed to send tone signals on a pulse dial line.
15	[/P] key (#/P)	When using the copy function, press this key to use a job program. When using the fax function, this key can be used when dialling.
16	[CLEAR ALL] key (CA)	Press this key to return to the initial operation state. Use this key when you wish to cancel all settings that have been selected and start operation from the initial state.
17	[STOP] key (⏹)	Press this key to stop a copy job or scanning of an original.
18	[POWER SAVE] key (⏻) / indicator	Use this key to put the machine into auto power shut-off mode to save energy. The [POWER SAVE] key (⏻) blinks when the machine is in auto power shut-off mode.

## B. 26cpm/36cpm/31cpm(A) machine

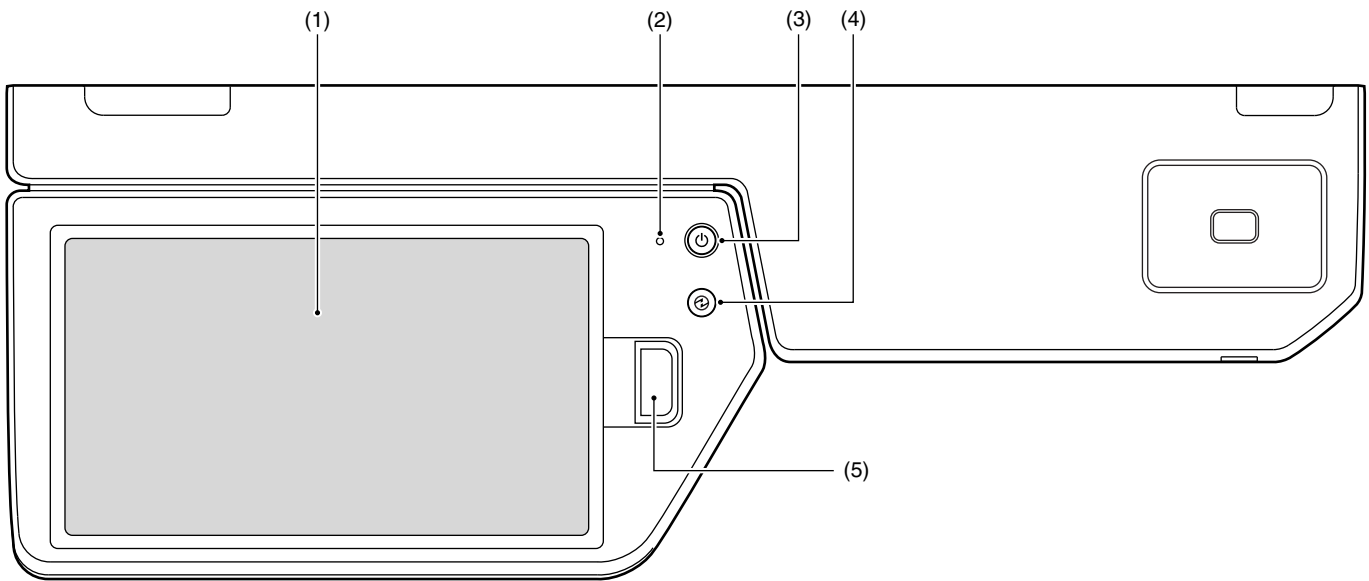

No.	Name	Function/Operation
1	Touch panel	Messages and keys appear in the touch panel display. Touch the displayed keys to perform a variety of operations. When a key is touched, a beep sounds and the selected item is highlighted. This provides confirmation as you perform an operation.
2	Main power indicator	This lights up when the machine's main power switch is in the "on" position.
3	[POWER] key (⏻)	Use this key to turn the machine power on and off.
4	[POWER SAVE] key (⏻) / indicator	Use this key to put the machine into auto power shut-off mode to save energy. The [POWER SAVE] key (⏻) blinks when the machine is in auto power shut-off mode.
5	[HOME] key / indicator	Touch this key to display the home screen. Frequently used settings can be registered in the home screen to enable quick and easy operation of the machine.



## 5. Sensors and detectors

### A. 18cpm/20cpm/23cpm/26cpm/31cpm machine

#### (1) 18cpm/20cpm machine

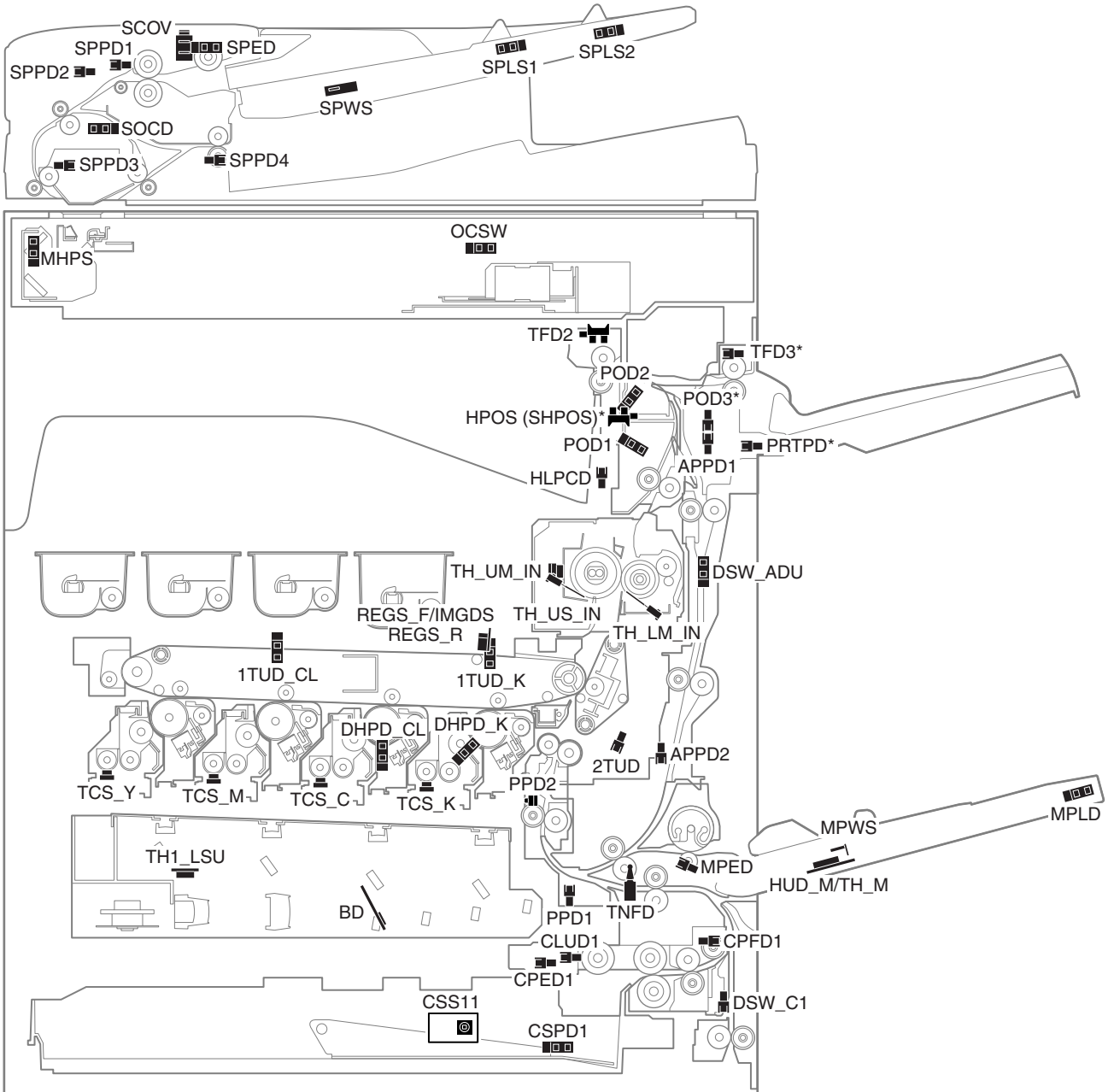

(2) 23cpm/26cpm/31cpm machine

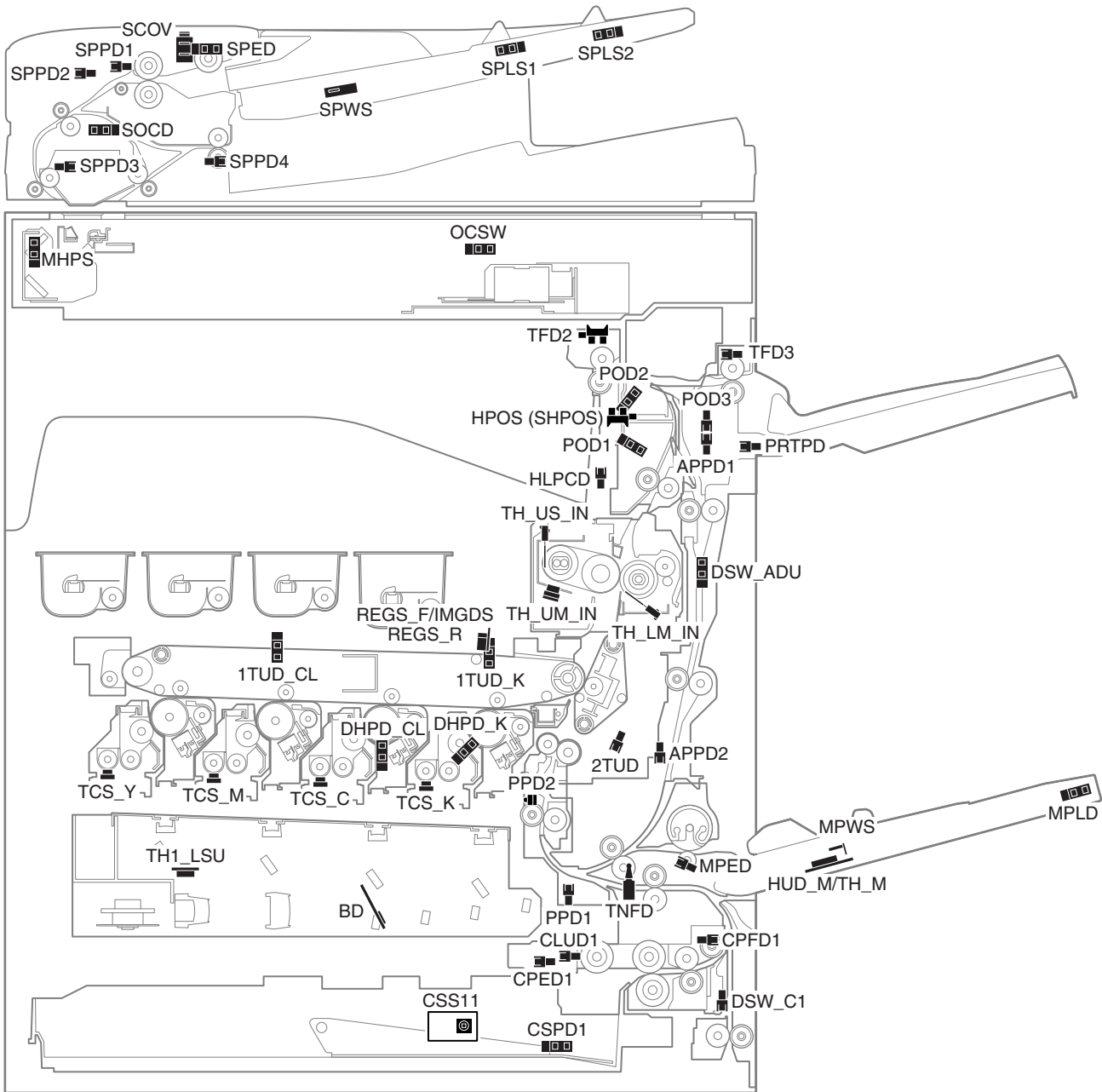

Signal name	Name	Type	Function/Operation	Note
1TUD_CL	Transfer mode detector (CL)	Transmission type	Detects separation of the transfer belt and the transfer mode. (Detection is made by combination of 1TUD_CL/1TUD_K signals.)	
1TUD_K	Transfer mode detector (BK)	Transmission type	Detects separation of the transfer belt and the transfer mode. (Detection is made by combination of 1TUD_CL/1TUD_K signals.)	
2TUD	Secondary transfer position detector	Transmission type	Detects the position (separation) of the secondary transfer unit.	
APPD1	ADU paper transport detector 1	Transmission type	Detects paper entry and paper pass in the ADU.	
APPD2	ADU paper transport detector 2	Transmission type	Detects paper pass in the ADU transport roller 8.	
BD	Laser beam detector	Pin diode	Detects laser beams (monitor.)	
CLUD1	Paper feed tray upper limit sensor (Paper feed tray 1)	Transmission type	Detects the upper limit of the paper lift up. (Paper feed tray 1)	
CPED1	Paper empty sensor (Paper feed tray 1)	Transmission type	Detects paper empty. (Paper feed tray 1)	
CPFD1	Paper transport detector (Paper feed tray 1)	Transmission type	Detects paper pass in the paper transport section of the paper feed tray 1.	
CSPD1	Paper remaining quantity sensor (Paper feed tray 1)	Transmission type	Detects the paper remaining quantity. (Paper feed tray 1)	

Signal name	Name	Type	Function/Operation	Note
CSS11	Paper feed tray size detector (Paper feed tray 1)	Tact switch	Detects the paper size. Detects closing of the paper feed tray. (Paper feed tray 1)	
DHPD_CL	OPC drum rotation sensor (CL)	Transmission type	Detects rotation and the phase of the OPC drum (CL).	
DHPD_K	OPC drum rotation sensor (BK)	Transmission type	Detects rotation and the phase of the OPC drum (BK).	
DSW_ADU	ADU paper guide open/close detector	Transmission type	Detects open/close of the ADU paper guide.	
DSW_C1	Transport cover open/close detector (Paper feed tray 1)	Transmission type	Detects open/close of the transport section cover. (Paper feed tray 1)	
HLPCD	Fusing pressure detector	Transmission type	Detects the fusing pressure state.	
HPOS (SHPOS)	Shifter home positions sensor	Transmission type	Detects the shifter home position.	* 18cpm machine are not installed.
HUD_M/TH_M	Temperature/humidity sensor	Thermistor	Detects the temperature and the humidity. (For the process control)	Analog detection
MHPS	Scanner home position sensor	Transmission type	Detects the scanner home position.	
MPED	Paper empty sensor (Manual paper feed tray)	Transmission type	Detects presence of paper. (Manual paper feed tray)	
MPLD	Paper length detector (Manual paper feed tray)	Transmission type	Detects the paper length. (Manual paper feed tray)	
MPWS	Paper width detector (Manual paper feed tray)	Volume-type resistor	Detects the paper width. (Manual paper feed tray)	
OCSW	Paper size detection trigger sensor	Transmission type	Detects generation of the paper size detection trigger signal.	
POD1	Paper exit detector 1	Transmission type	Detects paper transport from the fusing section.	
POD2	Paper exit detector 2	Transmission type	Detects paper transport to the face-down paper exit tray.	
POD3	Paper exit detector 3	Transmission type	Detects paper transport to the right paper exit tray.	* 18cpm machine are not installed.
PPD1	Paper transport detector 1	Transmission type	Detects paper pass in front of the transport roller 5.	
PPD2	Paper transport detector 2	Reflection type	Detects paper pass in the transport roller 5 in front of the registration roller.	
PRTPD	Paper exit tray paper detector (Right paper exit tray)	Transmission type	Detects paper empty in the paper exit tray (Right paper exit tray).	* 18cpm machine are not installed.
REGS_F/IMGDS	Registration sensor F (Image density sensor)	Reflection type	Detects color shift. (F side) / Detects the toner patch density.	
REGS_R	Registration sensor R (Image density sensor)	Reflection type	Detects the toner patch density.	
SCOV	RSPF cover open/close detector	Micro switch	Detects open/close of the RSPF cover.	
SOCD	RSPF open/close sensor	Transmission type	Detects open/close of the RSPF unit.	
SPED	Document sensor	Transmission type	Detects document empty in the RSPF paper feed tray.	
SPLS1	Paper size detector 1	Transmission type	Detects the document length in the RSPF paper feed tray.	
SPLS2	Paper size detector 2	Transmission type	Detects the document length in the RSPF paper feed tray.	
SPPD1	Document transport sensor 1	Transmission type	Detects paper feed and the document size in random paper feed.	
SPPD2	Document transport sensor 2	Transmission type	Detects paper pass.	
SPPD3	Document transport sensor 3	Transmission type	Detects paper pass.	
SPPD4	Document transport sensor 4	Transmission type	Detects paper exit and switchback.	
SPWS	Document size detector	Volume-type resistor	Detects the document width.	
TCS_C	Toner sensor (C)	Magnetic sensor	Detects toner supply from the toner cartridge. Detects the toner density (C).	Analog detection
TCS_K	Toner sensor (K)	Magnetic sensor	Detects toner supply from the toner cartridge. Detects the toner density (K).	Analog detection
TCS_M	Toner sensor (M)	Magnetic sensor	Detects toner supply from the toner cartridge. Detects the toner density (M).	Analog detection
TCS_Y	Toner sensor (Y)	Magnetic sensor	Detects toner supply from the toner cartridge. Detects the toner density (Y).	Analog detection
TFD2	Paper exit tray full detector (Center paper exit tray)	Transmission type	Detects paper full in the center paper exit tray.	
TFD3	Paper exit tray full detector (Right paper exit tray)	Transmission type	Detects paper full in the right paper exit tray.	* 18cpm machine are not installed.
TH_LM_IN	Fusing temperature sensor	Thermistor	Detects the surface temperature of the fusing roller (B).	Analog detection
TH_UM_IN	Fusing temperature sensor (Main)	Non-contact thermistor	Detects the surface temperature at the center of the fusing belt (roller).	Analog detection
TH_US_IN	Fusing temperature sensor (Sub)	Thermistor	Detects the suffered temperature at the edge section of the fusing belt (roller).	Analog detection
TH1_LSU	LSU temperature sensor	Thermistor	Detects the temperature in the LSU. (For correction of the LSU distortion)	Analog detection
TNFD	Waste toner full detector	Mechanical switch	Detects full of waste toner.	

## B. 36cpm machine

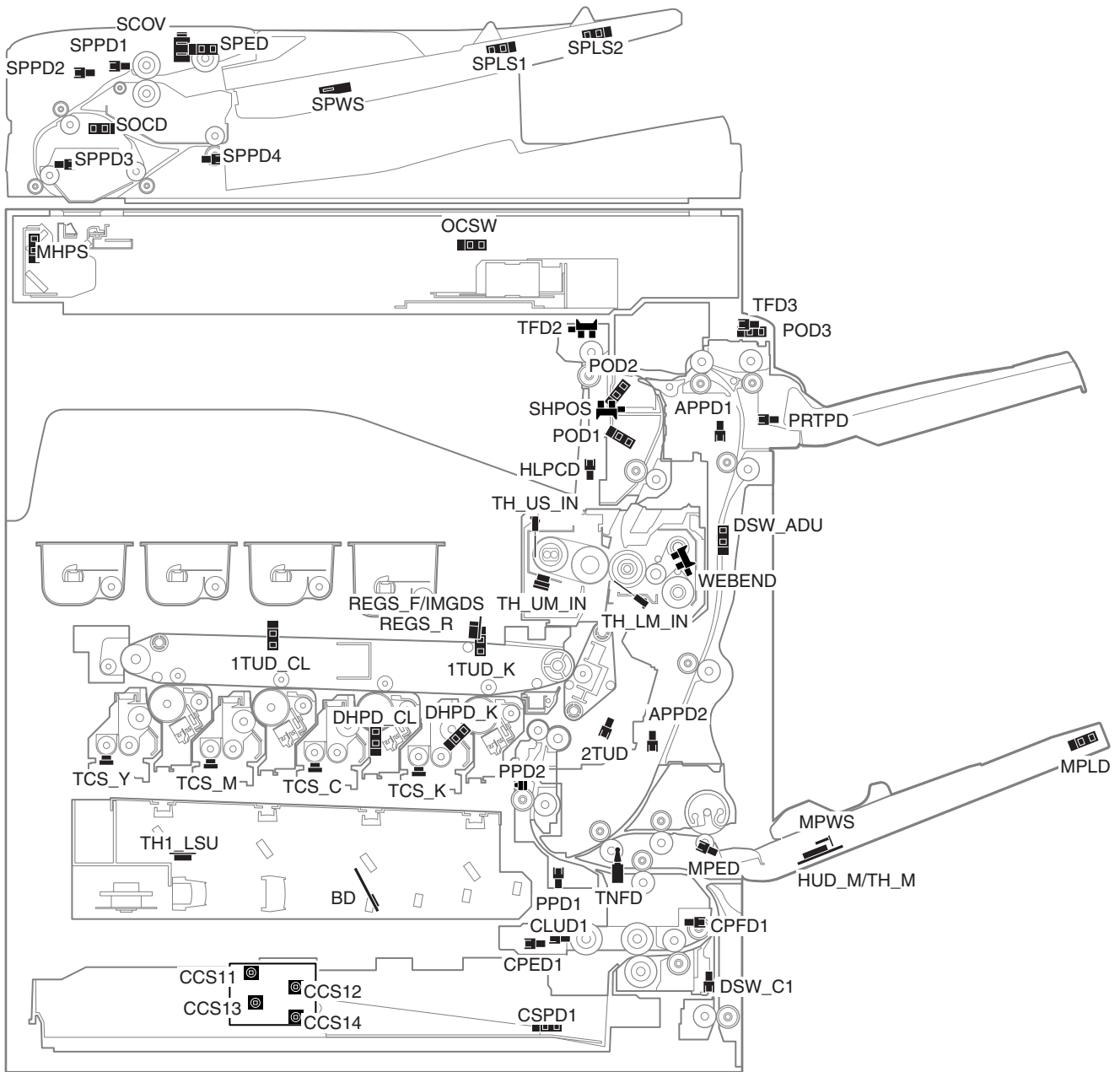

Signal name	Name	Type	Function/Operation	Note
1TUD_CL	Transfer mode detector (CL)	Transmission type	Detects separation of the transfer belt and the transfer mode. (Detection is made by combination of 1TUD_CL/1TUD_K signals.)	
1TUD_K	Transfer mode detector (BK)	Transmission type	Detects separation of the transfer belt and the transfer mode. (Detection is made by combination of 1TUD_CL/1TUD_K signals.)	
2TUD	Secondary transfer position detector	Transmission type	Detects the position (separation) of the secondary transfer unit.	
APPD1	ADU paper transport detector 1	Transmission type	Detects paper entry and paper pass in the ADU.	
APPD2	ADU paper transport detector 2	Transmission type	Detects paper pass in the ADU transport roller 8.	
BD	Laser beam detector	Pin diode	Detects laser beams (monitor.)	
CLUD1	Paper feed tray upper limit sensor (Paper feed tray 1)	Transmission type	Detects the upper limit of the paper lift up. (Paper feed tray 1)	
CPED1	Paper empty sensor (Paper feed tray 1)	Transmission type	Detects paper empty. (Paper feed tray 1)	
CPFD1	Paper transport detector (Paper feed tray 1)	Transmission type	Detects paper pass in the paper transport section of the paper feed tray 1.	
CSPD1	Paper remaining quantity sensor (Paper feed tray 1)	Transmission type	Detects the paper remaining quantity. (Paper feed tray 1)	

Signal name	Name	Type	Function/Operation	Note
CSS11	Paper feed tray size detector (Paper feed tray 1)	Tact switch	Detects the paper size. Detects closing of the paper feed tray. (Paper feed tray 1)	
CSS12				
CSS13				
CSS14				
DHPD_CL	OPC drum rotation sensor (CL)	Transmission type	Detects rotation and the phase of the OPC drum (CL).	
DHPD_K	OPC drum rotation sensor (BK)	Transmission type	Detects rotation and the phase of the OPC drum (BK).	
DSW_ADU	ADU paper guide open/close detector	Transmission type	Detects open/close of the ADU paper guide.	
DSW_C1	Transport cover open/close detector (Paper feed tray 1)	Transmission type	Detects open/close of the transport section cover. (Paper feed tray 1)	
HLPCD	Fusing pressure detector	Transmission type	Detects the fusing pressure state.	
SHPOS	Shifter home positions sensor	Transmission type	Detects the shifter home position.	
HUD_M/TH_M	Temperature/humidity sensor	Thermistor	Detects the temperature and the humidity. (For the process control)	Analog detection
MHPS	Scanner home position sensor	Transmission type	Detects the scanner home position.	
MPED	Paper empty sensor (Manual paper feed tray)	Transmission type	Detects presence of paper. (Manual paper feed tray)	
MPLD	Paper length detector (Manual paper feed tray)	Transmission type	Detects the paper length. (Manual paper feed tray)	
MPWS	Paper width detector (Manual paper feed tray)	Volume-type resistor	Detects the paper width. (Manual paper feed tray)	
OCSW	Paper size detection trigger sensor	Transmission type	Detects generation of the paper size detection trigger signal.	
POD1	Paper exit detector 1	Transmission type	Detects paper transport from the fusing section.	
POD2	Paper exit detector 2	Transmission type	Detects paper transport to the face-down paper exit tray.	
POD3	Paper exit detector 3	Transmission type	Detects paper transport to the right paper exit tray.	
PPD1	Paper transport detector 1	Transmission type	Detects paper pass in front of the transport roller 5.	
PPD2	Paper transport detector 2	Reflection type	Detects paper pass in the transport roller 5 in front of the registration roller.	
PRTPD	Paper exit tray paper detector (Right paper exit tray)	Transmission type	Detects paper empty in the paper exit tray (Right paper exit tray).	
REGS_F/IMGDS	Registration sensor F (Image density sensor)	Reflection type	Detects color shift. (F side) / Detects the toner patch density.	
REGS_R	Registration sensor R (Image density sensor)	Reflection type	Detects the toner patch density.	
SCOV	RSPF cover open/close detector	Micro switch	Detects open/close of the RSPF cover.	
SOCD	RSPF open/close sensor	Transmission type	Detects open/close of the RSPF unit.	
SPED	Document sensor	Transmission type	Detects document empty in the RSPF paper feed tray.	
SPLS1	Paper size detector 1	Transmission type	Detects the document length in the RSPF paper feed tray.	
SPLS2	Paper size detector 2	Transmission type	Detects the document length in the RSPF paper feed tray.	
SPPD1	Document transport sensor 1	Transmission type	Detects paper feed and the document size in random paper feed.	
SPPD2	Document transport sensor 2	Transmission type	Detects paper pass.	
SPPD3	Document transport sensor 3	Transmission type	Detects paper pass.	
SPPD4	Document transport sensor 4	Transmission type	Detects paper exit and switchback.	
SPWS	Document size detector	Volume-type resistor	Detects the document width.	
TCS_C	Toner sensor (C)	Magnetic sensor	Detects toner supply from the toner cartridge. Detects the toner density (C).	Analog detection
TCS_K	Toner sensor (K)	Magnetic sensor	Detects toner supply from the toner cartridge. Detects the toner density (K).	Analog detection
TCS_M	Toner sensor (M)	Magnetic sensor	Detects toner supply from the toner cartridge. Detects the toner density (M).	Analog detection
TCS_Y	Toner sensor (Y)	Magnetic sensor	Detects toner supply from the toner cartridge. Detects the toner density (Y).	Analog detection
TFD2	Paper exit tray full detector (Center paper exit tray)	Transmission type	Detects paper full in the center paper exit tray.	
TFD3	Paper exit tray full detector (Right paper exit tray)	Transmission type	Detects paper full in the right paper exit tray.	
TH_LM_IN	Fusing temperature sensor	Thermistor	Detects the surface temperature of the fusing roller (B).	Analog detection
TH_UM_IN	Fusing temperature sensor (Main)	Non-contact thermistor	Detects the surface temperature at the center of the fusing belt.	Analog detection
TH_US_IN	Fusing temperature sensor (Sub)	Thermistor	Detects the suffered temperature at the edge section of the fusing belt.	Analog detection
TH1_LSU	LSU temperature sensor	Thermistor	Detects the temperature in the LSU. (For correction of the LSU distortion)	Analog detection
TNFD	Waste toner full detector	Mechanical switch	Detects full of waste toner.	
WEBEND	Web end detector	Transmission type	Detects web end of the fusing unit.	

## 6. Switches

### A. 18cpm/20cpm/23cpm/31cpm(G) machine

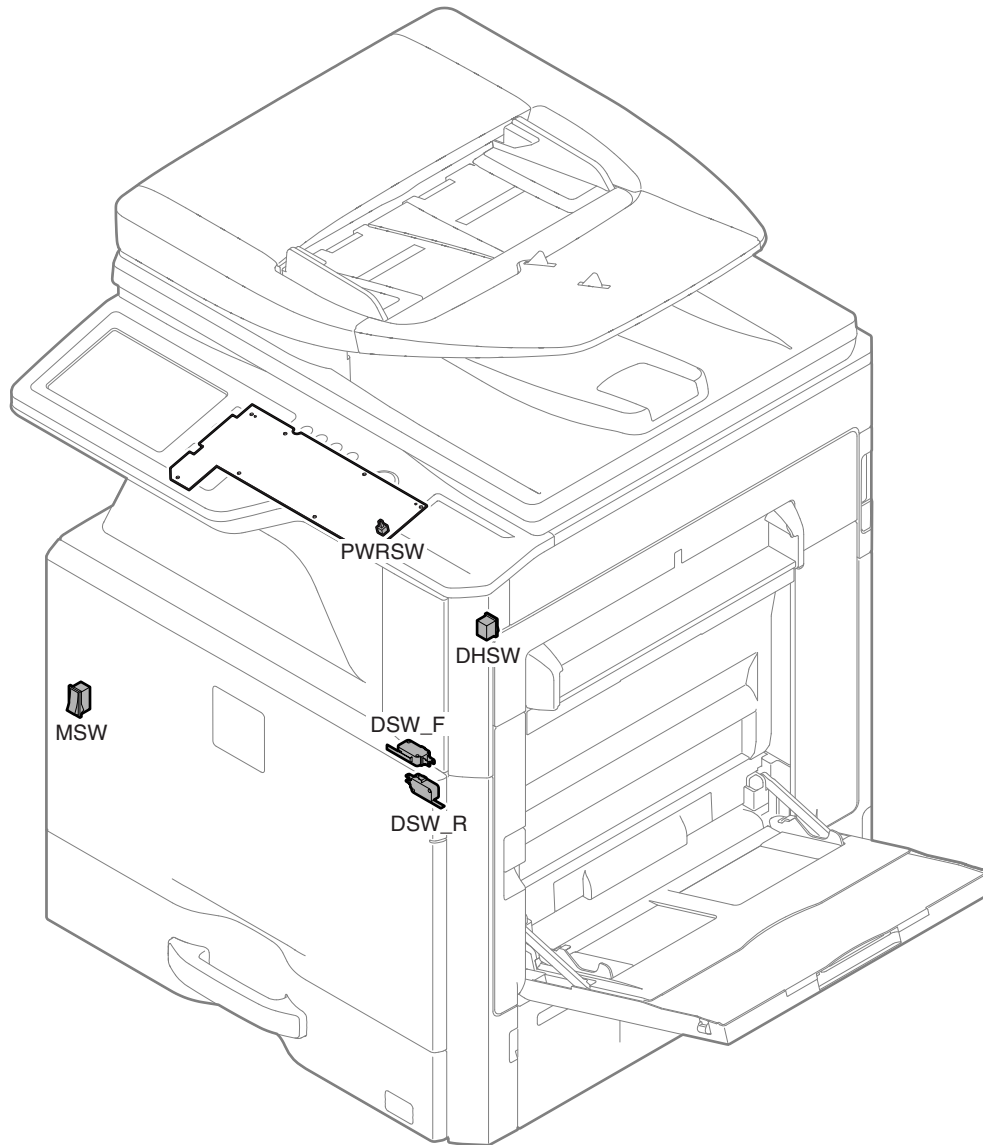

Signal name	Name	Type	Function/Operation
DHSW	Dehumidifier heater switch	Seesaw switch	Turns ON/OFF the power line of the dehumidifier heater.
DSW_F	Front door open/close switch	Micro switch	Detects open/close of the front door. Detects ON/OFF of the power line of the fusing unit, the motors, and the LSU laser.
DSW_R	Right transport unit (right door) open/close switch	Micro switch	Detects open/close of the right paper transport section (right door). Detects ON/OFF of the power line of the fusing unit, the motors, and the LSU laser.
MSW	Main power switch	Seesaw switch	Turns ON/OFF the main power.
PWRSW	Operation panel power switch	Push switch	Turns ON/OFF the power on the secondary side.

## B. 26cpm/36cpm/31cpm(A) machine

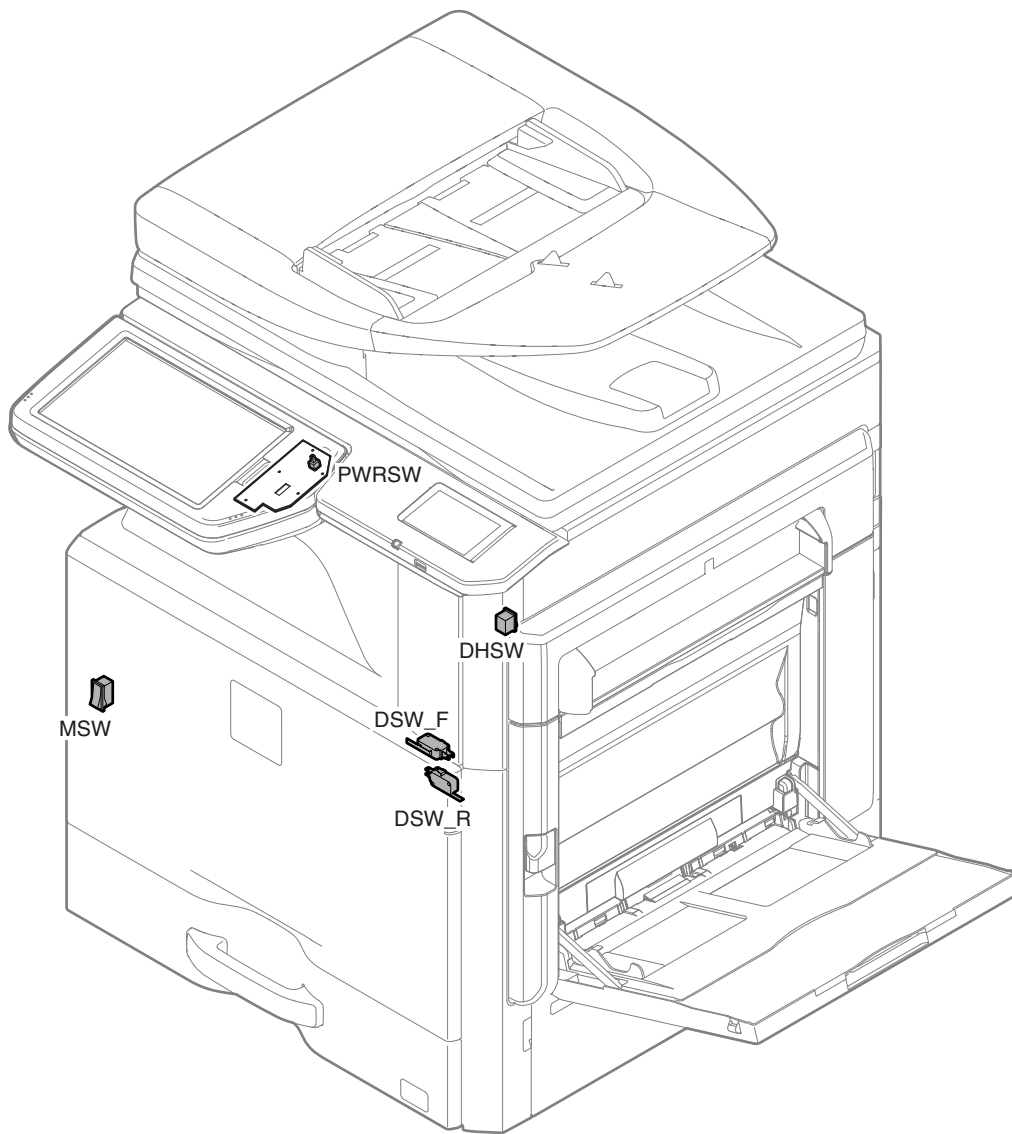

Signal name	Name	Type	Function/Operation
DHSW	Dehumidifier heater switch	Seesaw switch	Turns ON/OFF the power line of the dehumidifier heater.
DSW_F	Front door open/close switch	Micro switch	Detects open/close of the front door. Detects ON/OFF of the power line of the fusing unit, the motors, and the LSU laser.
DSW_R	Right transport unit (right door) open/close switch	Micro switch	Detects open/close of the right paper transport section (right door). Detects ON/OFF of the power line of the fusing unit, the motors, and the LSU laser.
MSW	Main power switch	Seesaw switch	Turns ON/OFF the main power.
PWRSW	Operation panel power switch	Push switch	Turns ON/OFF the power on the secondary side.

## 7. Clutches and solenoids

### A. 18cpm/20cpm/23cpm/26cpm/31cpm machine

#### (1) 18cpm/20cpm machine

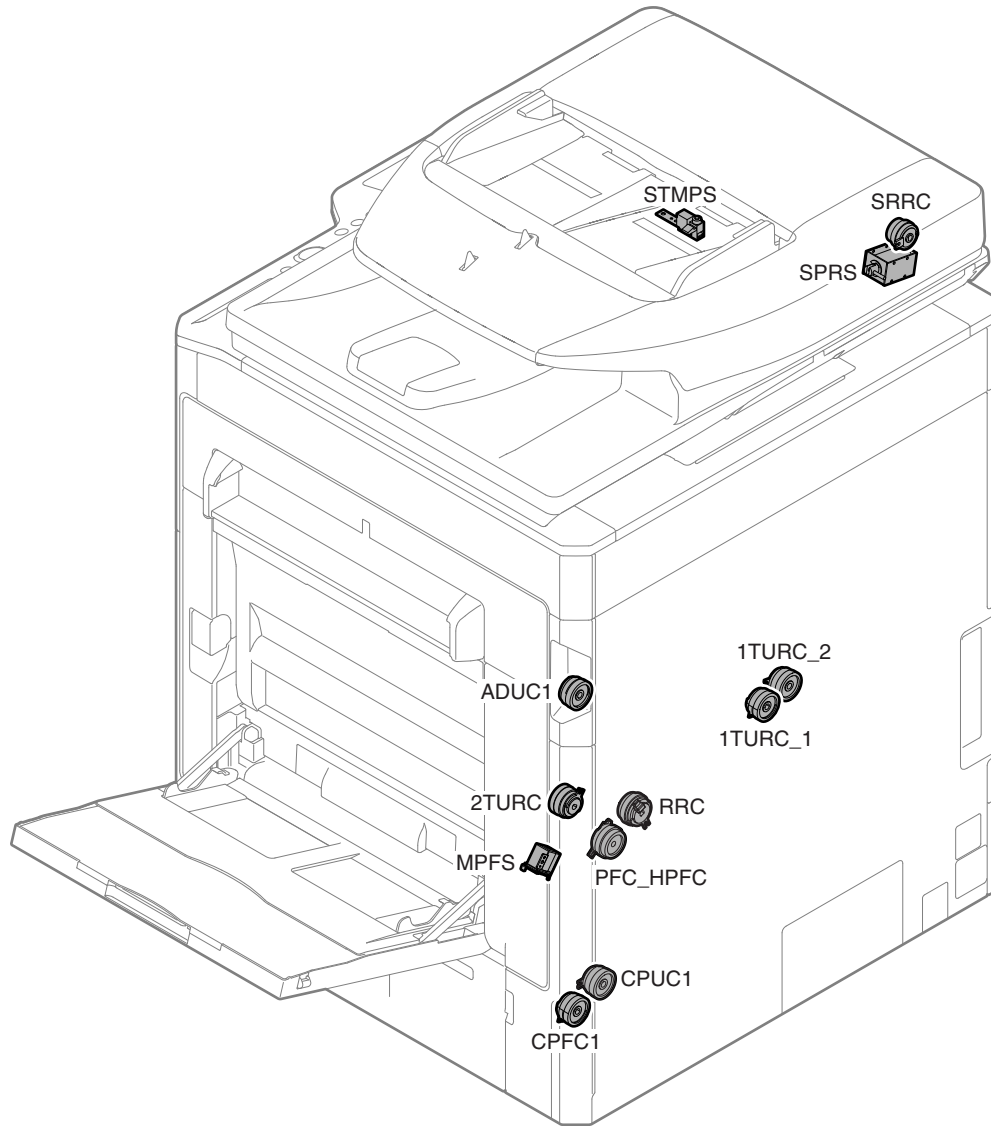



(2) 23cpm/26cpm/31cpm machine

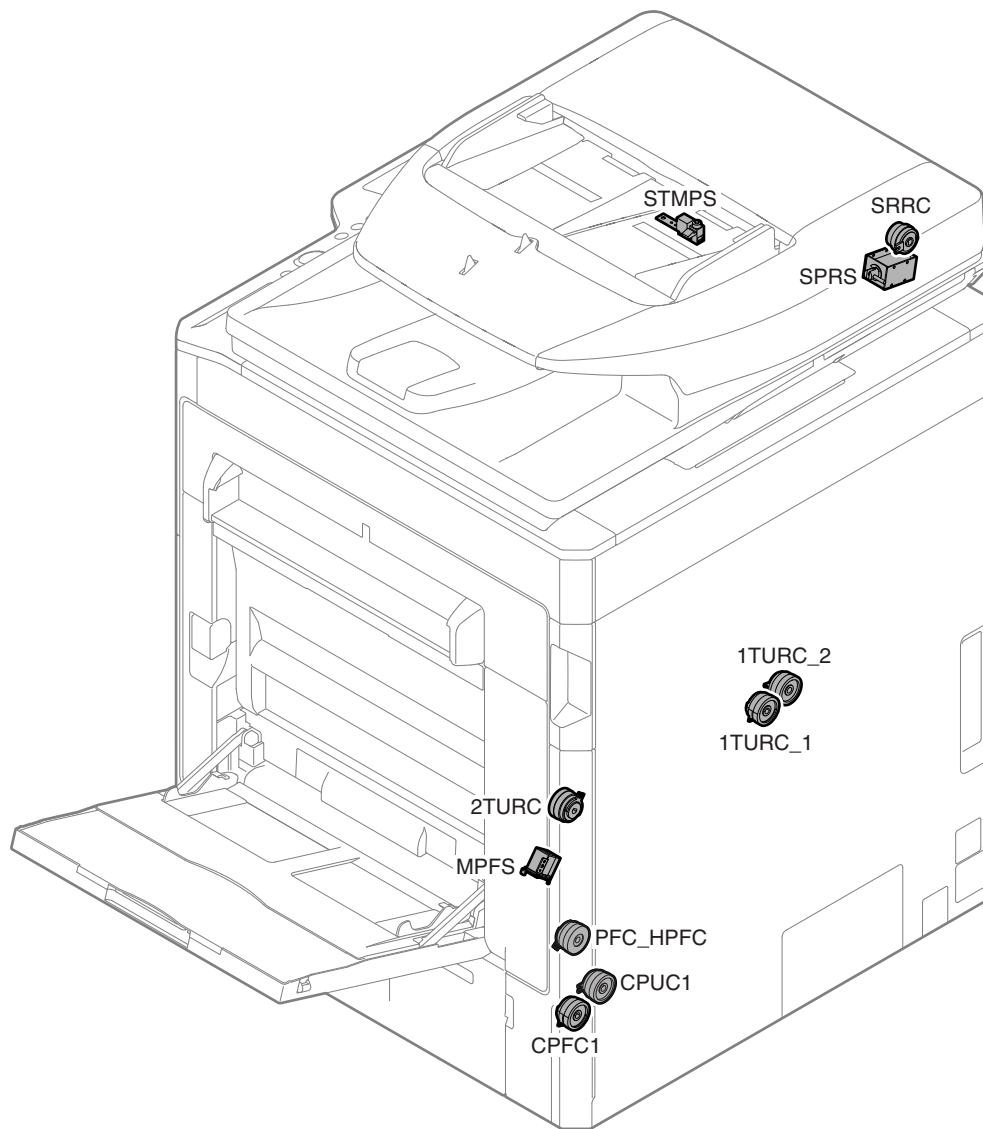

Signal name	Name	Type	Function/Operation
1TURC_1	Primary transfer separation clutch 1	Magnetic clutch	Controls separation of the primary transfer unit.
1TURC_2	Primary transfer separation clutch 2	Magnetic clutch	Controls separation of the primary transfer unit.
2TURC	Secondary transfer separation clutch	Magnetic clutch	Controls separation of the secondary transfer unit.
ADUC1	ADU clutch	Magnetic clutch	Controls the ADU and the transport roller in the right paper exit section.
CPFC1	Tray vertical transport clutch 1	Magnetic clutch	Controls the transport roller of the paper feed tray 1 section.
CPUC1	Paper feed clutch (Paper feed tray 1)	Magnetic clutch	Controls ON/OFF of the paper feed roller in the paper feed tray 1 section. (Paper feed tray 1)
MPFS	Paper feed solenoid (Manual paper feed)	Magnetic solenoid	Controls the paper feed roller. (Manual paper feed)
PFC_HPFC	Transport roller clutch	Magnetic clutch	Controls the transport roller 4. (23cpm/26cpm/31cpm machine)/Controls the transport roller 5, 6. (20cpm machine)
RRC	Registration roller clutch	Magnetic clutch	Controls the registration roller. (Controls the timing of the transfer image for the paper.)
SPRS	Paper exit roller pressure control solenoid (RSPF)	Magnetic solenoid	Controls ON/OFF of the transport power of the paper exit roller. (Releases the paper exit roller pressure when reversing paper.)
SRRC	Registration roller clutch (RSPF)	Magnetic clutch	Controls the registration roller. (Controls the timing of document transport.)
STMPS	Stamp solenoid	Magnetic solenoid	Drives the finish stamp.

## B. 36cpm machine

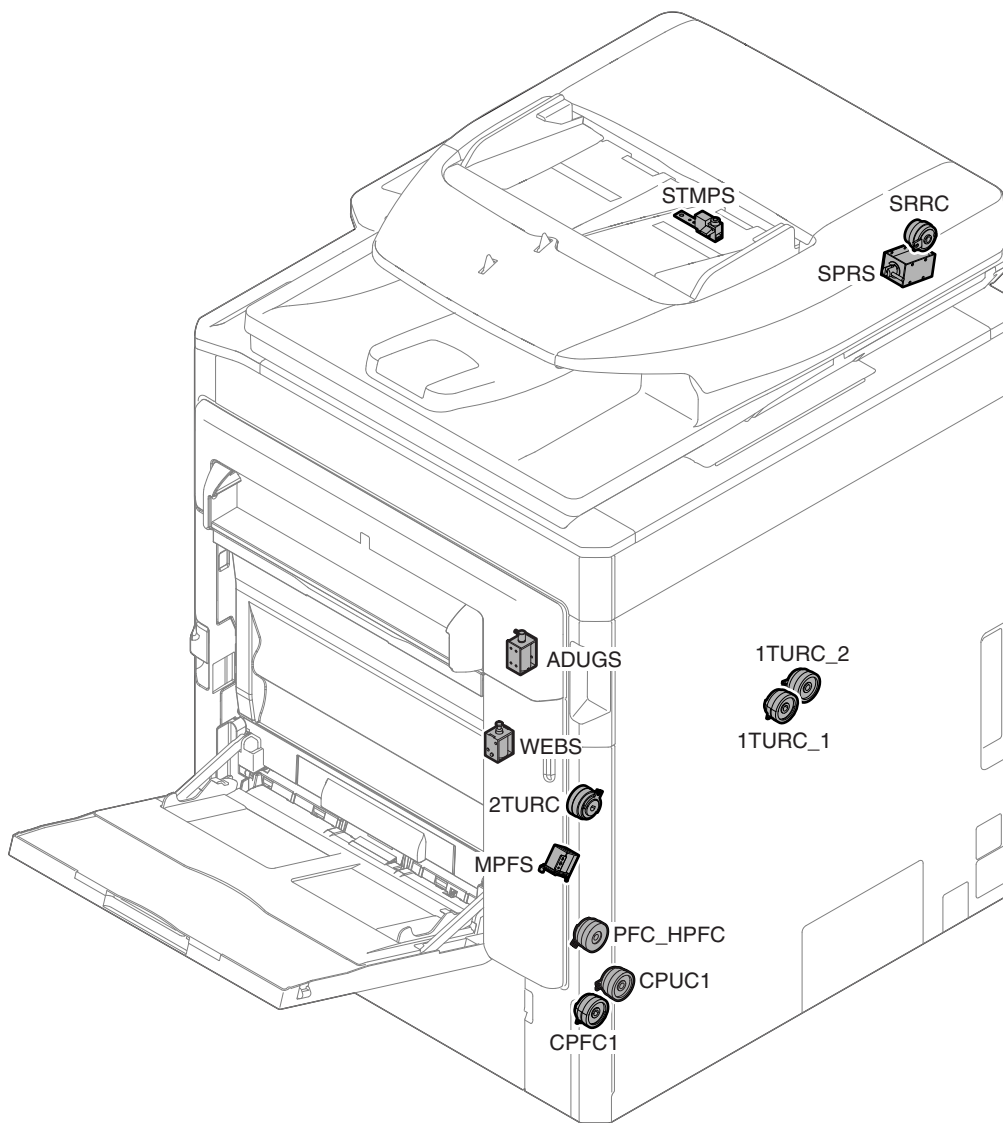

Signal name	Name	Type	Function/Operation
1TURC_1	Primary transfer separation clutch 1	Magnetic clutch	Controls separation of the primary transfer unit.
1TURC_2	Primary transfer separation clutch 2	Magnetic clutch	Controls separation of the primary transfer unit.
2TURC	Secondary transfer separation clutch	Magnetic clutch	Controls separation of the secondary transfer unit.
ADUGS	ADU gate solenoid	Magnetic solenoid	Controls the paper exit gate.
CPFC1	Tray vertical transport clutch 1	Magnetic clutch	Controls the transport roller of the paper feed tray 1 section.
CPUC1	Paper feed clutch (Paper feed tray 1)	Magnetic clutch	Controls ON/OFF of the paper feed roller in the paper feed tray 1 section. (Paper feed tray 1)
MPFS	Paper feed solenoid (Manual paper feed)	Magnetic solenoid	Controls the paper feed roller. (Manual paper feed)
PFC_HPFC	Transport roller clutch	Magnetic clutch	Controls the transport roller 4.
SPRS	Paper exit roller pressure control solenoid (RSPF)	Magnetic solenoid	Controls ON/OFF of the transport power of the paper exit roller. (Releases the paper exit roller pressure when reversing paper.)
SRRC	Registration roller clutch (RSPF)	Magnetic clutch	Controls the registration roller. (Controls the timing of document transport.)
STMPS	Stamp solenoid	Magnetic solenoid	Drives the finish stamp.
WEBS	Web drive solenoid	Magnetic solenoid	Drives the web.

## 8. Motors

### A. 18cpm/20cpm/23cpm/26cpm/31cpm machine

#### (1) 18cpm/20cpm machine

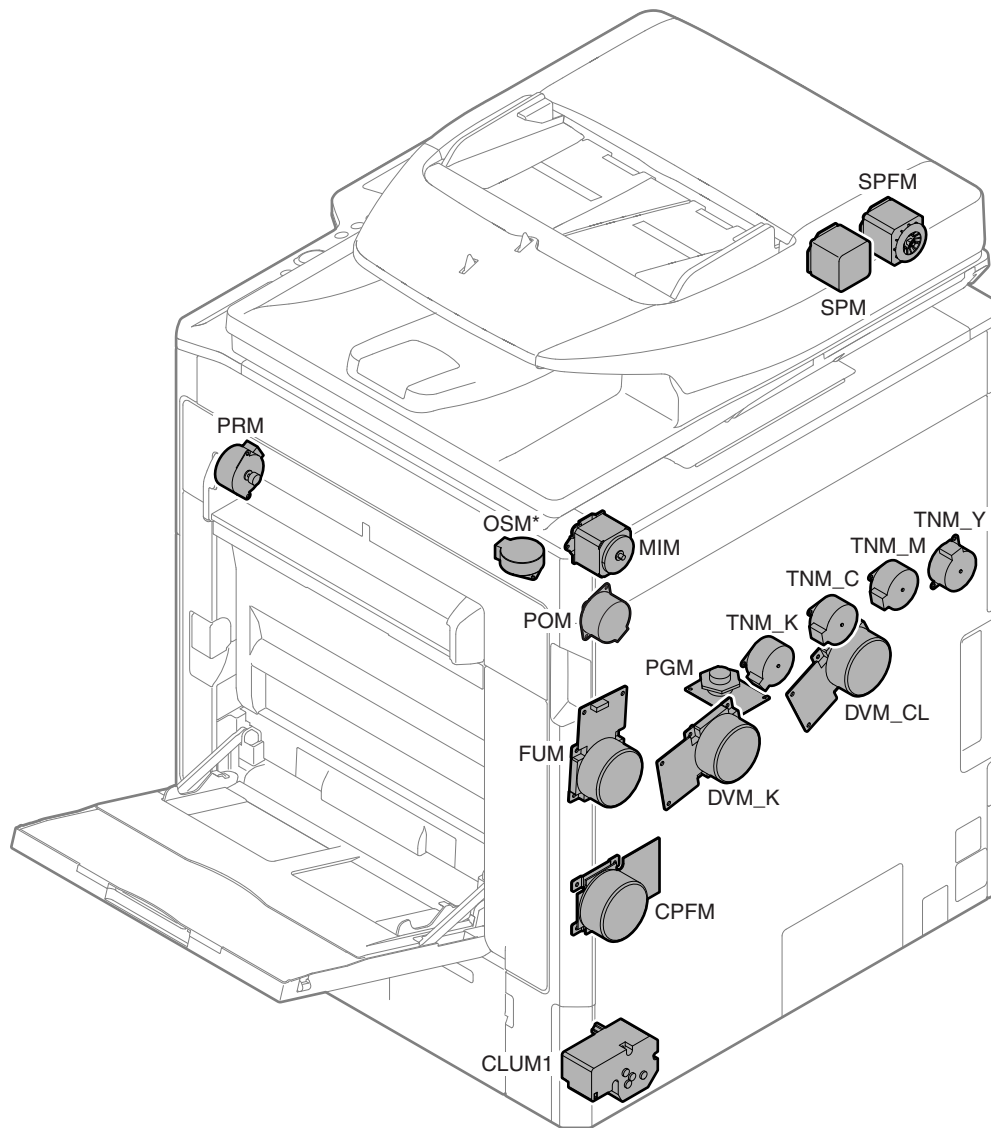

(2) 23cpm/26cpm/31cpm machine

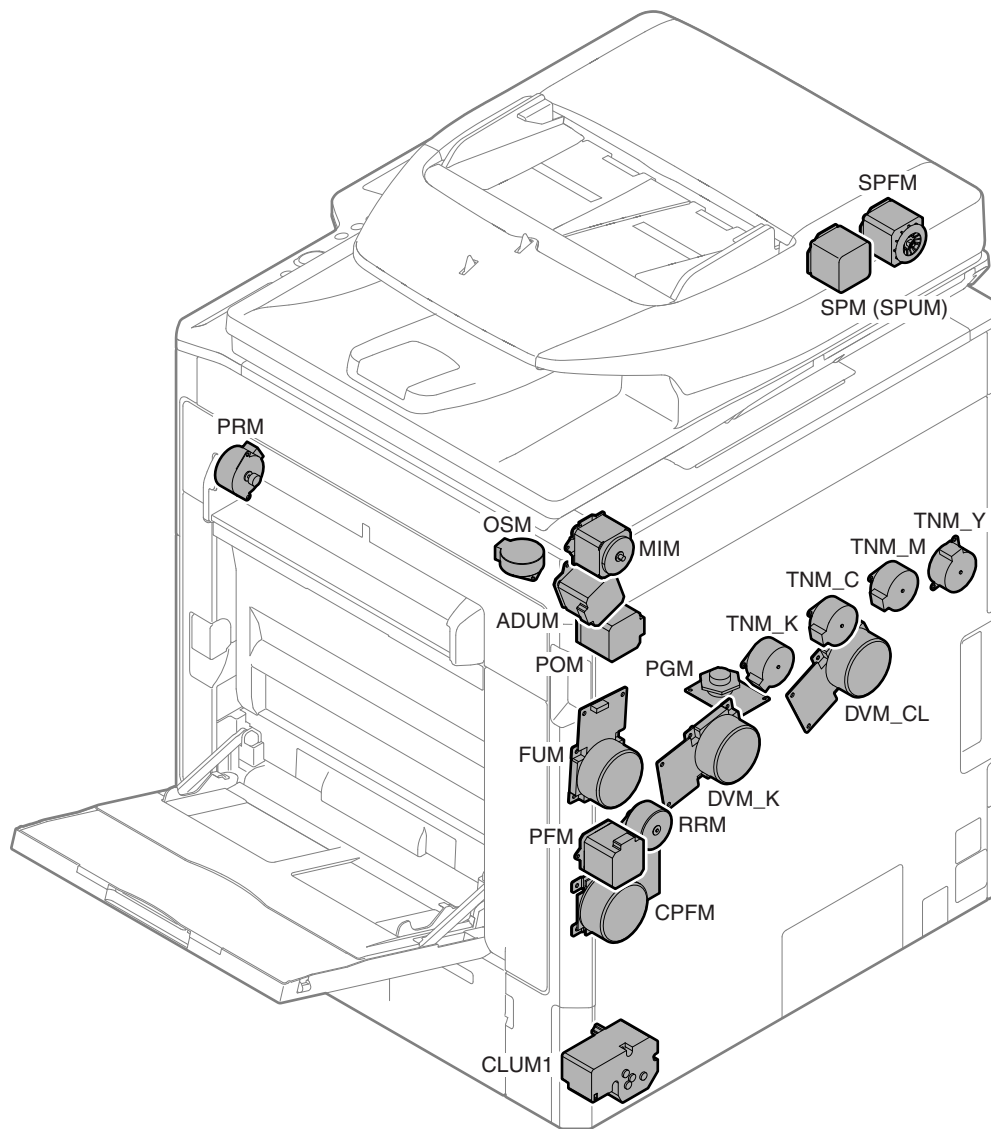

Signal name	Name	Type	Function/Operation
ADUM	ADU motor	Stepping motor	Drives the ADU and the transport roller in the right paper exit section.
CLUM1	Paper tray lift motor (Paper feed tray 1)	DC brush motor	Lifts the lift plate of the paper feed tray. (Paper feed tray 1)
CPFUM	Paper feed motor	DC brushless motor	Drives the paper feed section.
DVM_CL	Developing motor (CL)	DC brushless motor	Drives the developing/OPC drum section (CL).
DVM_K	Developing motor (K)	DC brushless motor	Drives the developing/black OPC drum (BK)/transfer section.
FUM	Fusing motor	DC brushless motor	Drives the fusing section.
MIM	Scan motor	Stepping motor	Drives the scanner unit. (scan, return operations)
OSM*	Offset motor	Stepping motor	Offsets (shifts) paper.
PFM	Transport motor	Stepping motor	Drives the transport rollers 5 and 9.
PGM	Polygon motor	DC brushless motor	Scans laser beams.
POM	Paper exit motor	Stepping motor	Drives the roller in the paper exit section.
PRM	Fusing pressure control motor	Stepping motor	Controls ON/OFF of the fusing roller pressure.
RRM	Registration motor	Stepping motor	Drives the registration roller. (Controls the timing of the transfer image for the paper.)
SPFM	RSPF transport motor	Stepping motor	Transports a document.
SPM/SPUM	RSPF paper feed motor	Stepping motor	Feeds a document.
TNM_C	Toner motor (C)	Stepping motor	Supplies toner from the toner cartridge (C) to the developing unit.
TNM_K	Toner motor (K)	Stepping motor	Supplies toner from the toner cartridge (K) to the developing unit.
TNM_M	Toner motor (M)	Stepping motor	Supplies toner from the toner cartridge (M) to the developing unit.
TNM_Y	Toner motor (Y)	Stepping motor	Supplies toner from the toner cartridge (Y) to the developing unit.

\* 18cpm machine are not installed.

## B. 36cpm machine

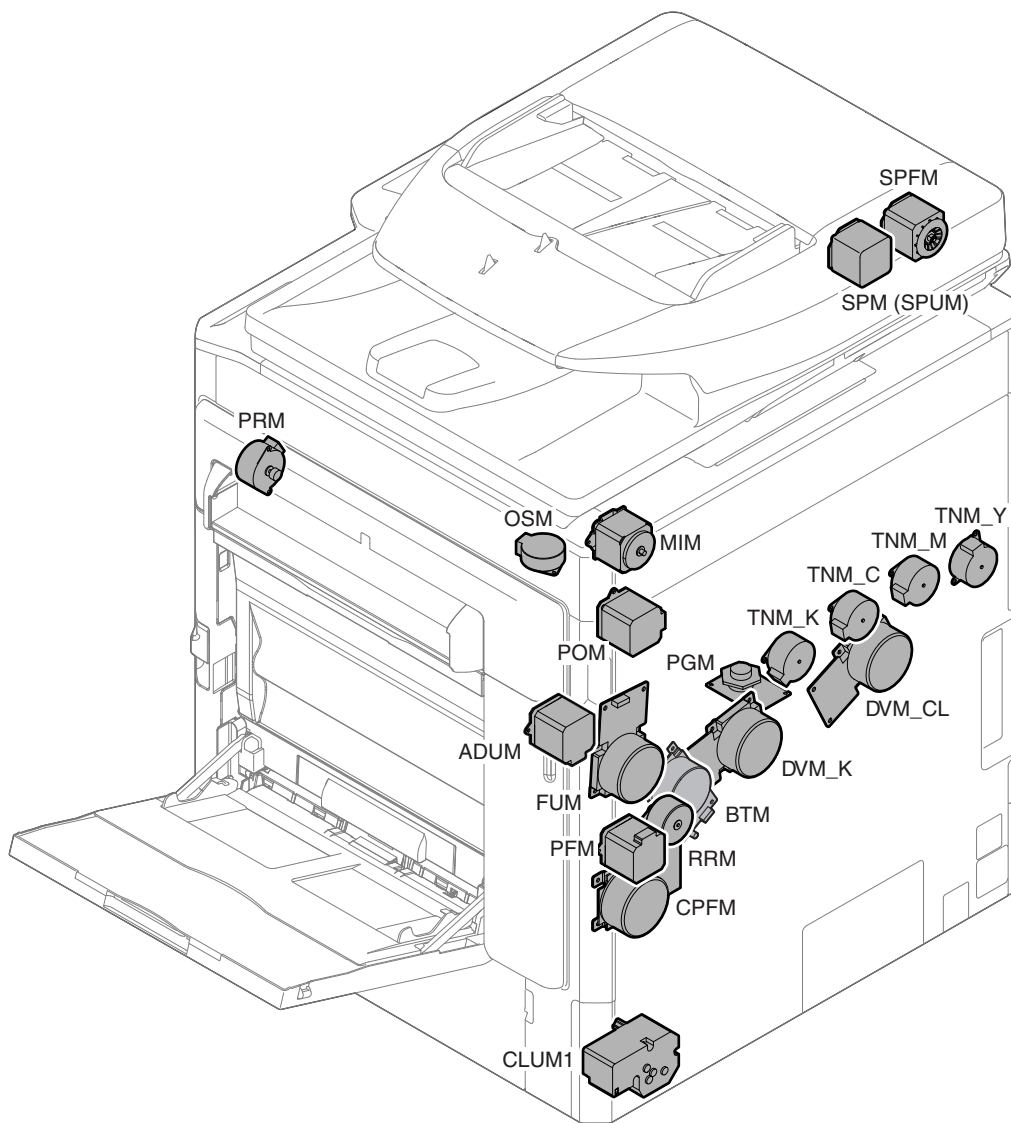

Signal name	Name	Type	Function/Operation
ADUM	ADU motor	Stepping motor	Drives the ADU and the transport roller in the right paper exit section.
BTM	Transfer belt drive motor	DC brushless motor	Drives the transfer belt.
CLUM1	Paper tray lift motor (Paper feed tray 1)	DC brush motor	Lifts the lift plate of the paper feed tray. (Paper feed tray 1)
CPFM	Paper feed motor	DC brushless motor	Drives the paper feed section.
DVM_CL	Developing motor (CL)	DC brushless motor	Drives the developing/OPC drum section (CL).
DVM_K	Developing motor (K)	DC brushless motor	Drives the developing/black OPC drum (BK)/transfer section.
FUM	Fusing motor	DC brushless motor	Drives the fusing section.
MIM	Scan motor	Stepping motor	Drives the scanner unit. (scan, return operations)
OSM	Offset motor	Stepping motor	Offsets (shifts) paper.
PFM	Transport motor	Stepping motor	Drives the transport rollers 5 and 9.
PGM	Polygon motor	DC brushless motor	Scans laser beams.
POM	Paper exit motor	Stepping motor	Drives the roller in the paper exit section.
PRM	Fusing pressure control motor	Stepping motor	Controls ON/OFF of the fusing roller pressure.
RRM	Registration motor	Stepping motor	Drives the registration roller. (Controls the timing of the transfer image for the paper.)
SPFM	RSPF transport motor	Stepping motor	Transports a document.
SPM (SPUM)	RSPF paper feed motor	Stepping motor	Feeds a document.
TNM_C	Toner motor (C)	Stepping motor	Supplies toner from the toner cartridge (C) to the developing unit.
TNM_K	Toner motor (K)	Stepping motor	Supplies toner from the toner cartridge (K) to the developing unit.
TNM_M	Toner motor (M)	Stepping motor	Supplies toner from the toner cartridge (M) to the developing unit.
TNM_Y	Toner motor (Y)	Stepping motor	Supplies toner from the toner cartridge (Y) to the developing unit.

## 9. Rollers

### A. 18cpm/20cpm/23cpm/26cpm/31cpm machine

#### (1) 18cpm/20cpm machine

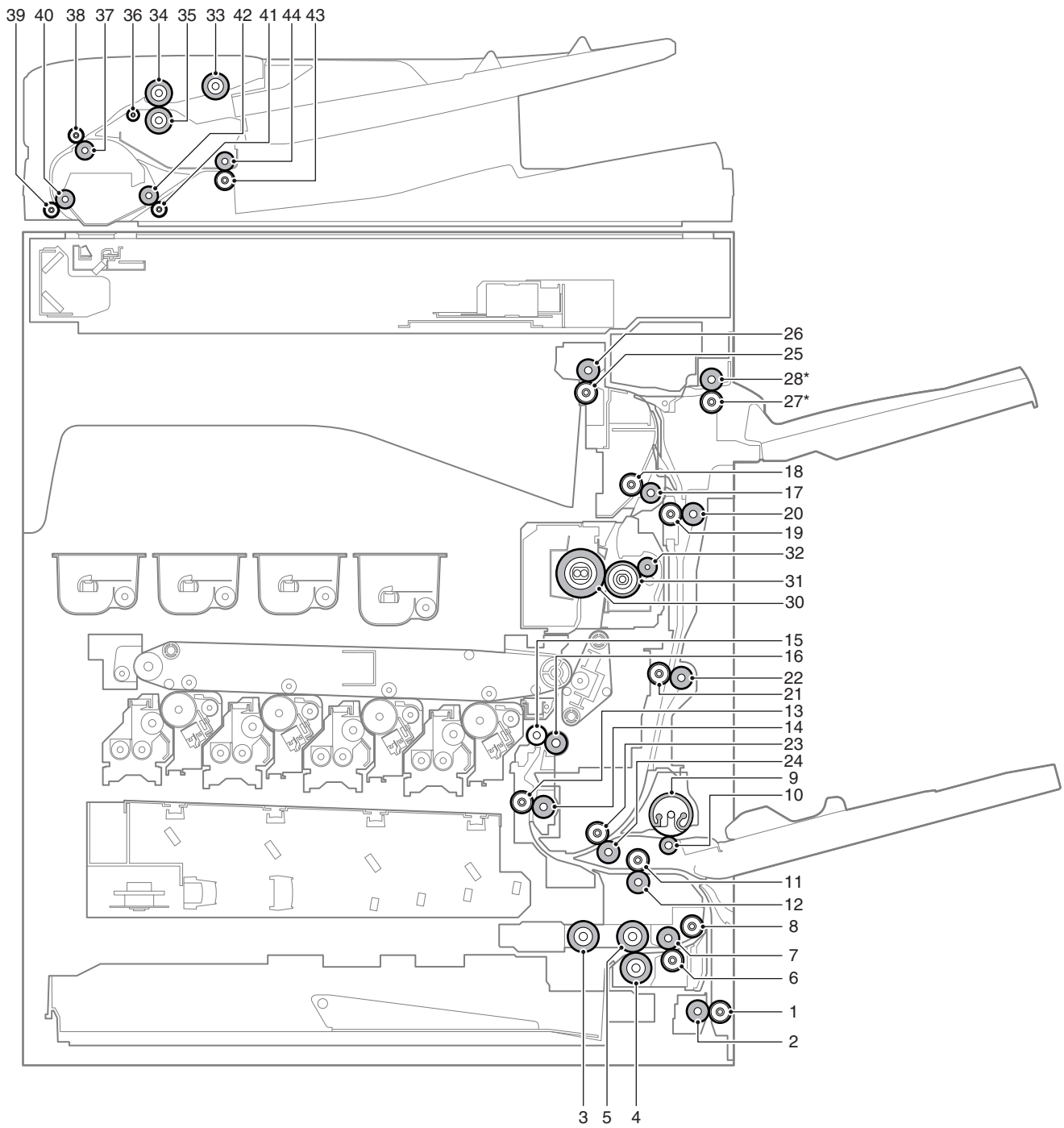

(2) 23cpm/26cpm/31cpm machine

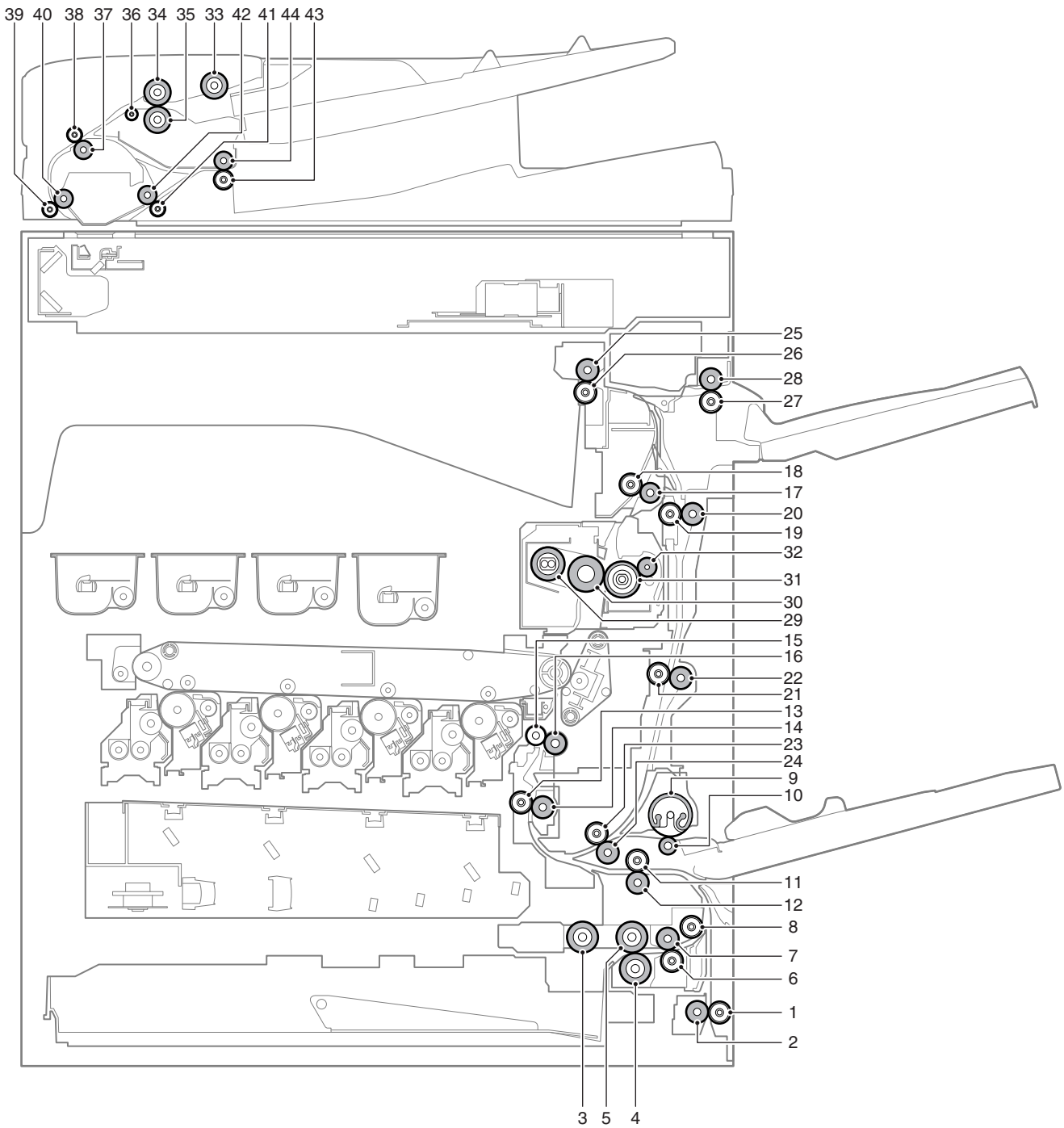

No.	Name	Function/Operation
1	Transport roller 1 (Idle)	Apply a pressure to paper and the transport roller to provide the transport power of the transport roller to paper.
2	Transport roller 1 (Drive)	Transports paper fed from the paper feed desk tray to the transport roller 4.
3	Paper pickup roller (No. 1 paper feed tray)	Feeds paper to the paper feed roller.
4	Separation roller (No. 1 paper feed tray)	Separates paper to prevent double-feeding.
5	Paper feed roller (No. 1 paper feed tray)	Feeds paper to the paper transport section.
6	Transport roller 2 (Idle)	Apply a pressure to paper and the transport roller to provide the transport power of the transport roller to paper.
7	Transport roller 2 (Drive)	Transports paper fed from the paper feed tray 1 to the transport roller 3.
8	Transport roller 3	Transports paper from the transport roller 2 to the transport roller 4.
9	Paper feed roller (Manual paper feed tray)	Feeds paper to the paper transport section.
10	Separation roller (Manual paper feed tray)	Separates paper to prevent double-feeding.
11	Transport roller 4 (Idle)	Apply a pressure to paper and the transport roller to provide the transport power of the transport roller to paper.
12	Transport roller 4 (Drive)	Transports paper from the transport rollers 1 and 3 to the transport roller 5.
13	Transport roller 5 (Idle)	Apply a pressure to paper and the transport roller to provide the transport power of the transport roller to paper.
14	Transport roller 5 (Drive)	Transports paper to the registration roller. Paper is buckled between the registration roller and this roller to correct the paper skew and the relation between images and paper.
15	Registration roller (Drive)	Transports paper to the transfer section. / Controls the transport timing of paper and adjusts relative relations between the image and paper.
16	Registration roller (Idle)	Apply a pressure to paper and the registration roller to provide the transport power of the transport roller to paper.
17	Transport roller 6 (Drive)	Transports paper transported from the fusing section to the paper exit section and the switchback section.
18	Transport roller 6 (Idle)	Apply a pressure to paper and the transport roller to provide the transport power of the transport roller to paper.
19	Transport roller 7 (Idle)	Apply a pressure to paper and the transport roller to provide the transport power of the transport roller to paper.
20	Transport roller 7 (Drive)	Transports paper transported from the switchback section to the transport roller 8.
21	Transport roller 8 (Idle)	Apply a pressure to paper and the transport roller to provide the transport power of the transport roller to paper.
22	Transport roller 8 (Drive)	Transports paper transported from the transport roller 7 to the transport roller 9.
23	Transport roller 9 (Idle)	Apply a pressure to paper and the transport roller to provide the transport power of the transport roller to paper.
24	Transport roller 9 (Drive)	Transports paper transported from the transport roller 8 to the transport roller 5.
25	Paper exit roller 1 (Idle)	Apply a pressure to paper and the paper exit roller to provide the transport power of the paper exit roller to paper.
26	Paper exit roller 1 (Drive)	Transports paper to the left paper exit section.
27	Paper exit roller 2 (Idle)*	Apply a pressure to paper and the paper exit roller to provide the transport power of the paper exit roller to paper.
28	Paper exit roller 2 (Drive)*	Discharges paper to the right paper exit tray.
29	Fusing roller (F1)	Heats the fusing belt.
30	Fusing roller (F2)	The cushion layer of the roller forms a wide nip between the fusing belt and fusing roller (B). (23cpm/26cpm/31cpm machine)/Heats the paper surface to fuse toner on the paper. (20cpm machine)
31	Fusing roller (B)	Heats the paper surface to fuse toner on the paper.
32	Fusing cleaning roller	Cleans the fusing roller (B) and the fusing belt.
33	Document pickup roller (RSPF)	Feeds a document to the paper feed roller.
34	Paper feed roller (RSPF)	Feeds a document to the transport section. Makes a buckle on paper between the registration roller and this roller to correct the start position of document skew and document image scan.
35	Separation roller (RSPF)	Separates a document to prevent double-feeding.
36	Transport auxiliary roller (RSPF)	Reduces friction between a document and the paper guide to transport the document smoothly to the registration roller.
37	Registration roller (Drive) (RSPF)	Transports a document to the transport roller 2. / Controls the transport timing of the document and adjusts the document scanning timing.
38	Registration roller (Idle) RSPF)	Apply a pressure to a document and the registration roller to provide the transport power of the transport roller to the document.
39	Transport roller 2 (Idle) (RSPF)	Apply a pressure to a document and the transport roller to provide the transport power of the transport roller to the document.
40	Transport roller 2 (Drive) (RSPF)	Transports a document transported from the registration roller to the document scanning section.
41	Transport roller 3 (Idle) (RSPF)	Apply a pressure to a document and the transport roller to provide the transport power of the transport roller to the document.
42	Transport roller 3 (Drive) (RSPF)	Transports a document transported from the document scanning section to the paper exit roller.
43	Paper exit roller (Idle) (RSPF)	Apply a pressure to a document and the paper exit roller to provide the transport power of the paper exit roller to the document.
44	Paper exit roller (Drive) (RSPF)	Discharges a document. Switchbacks the document and transports it to the registration roller when scanning the back surface.

\* 18cpm machine are not installed.



## B. 36cpm machine

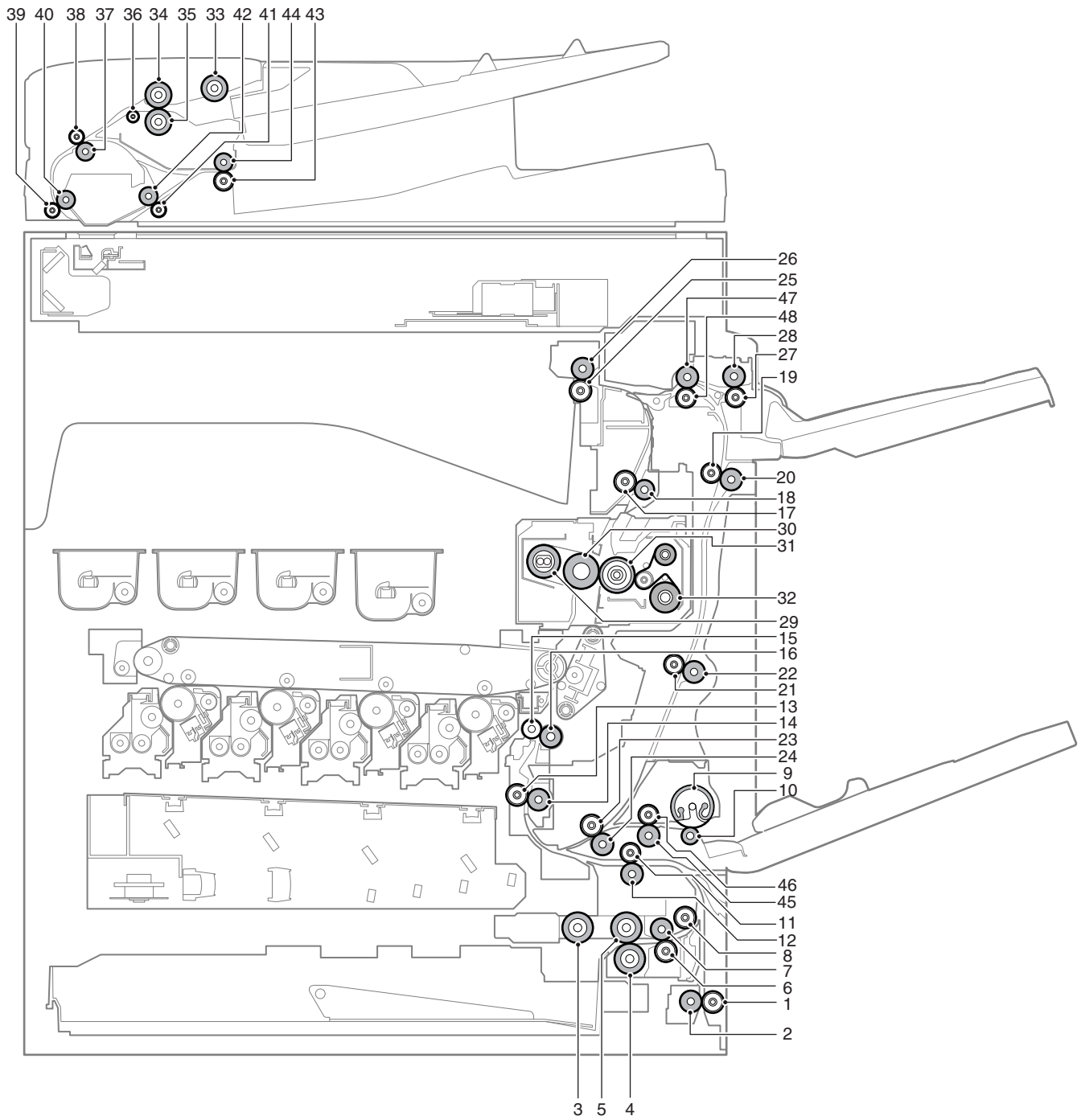

No.	Name	Function/Operation
1	Transport roller 1 (Idle)	Apply a pressure to paper and the transport roller to provide the transport power of the transport roller to paper.
2	Transport roller 1 (Drive)	Transports paper fed from the paper feed desk tray to the transport roller 4.
3	Paper pickup roller (No. 1 paper feed tray)	Feeds paper to the paper feed roller.
4	Separation roller (No. 1 paper feed tray)	Separates paper to prevent double-feeding.
5	Paper feed roller (No. 1 paper feed tray)	Feeds paper to the paper transport section.
6	Transport roller 2 (Idle)	Apply a pressure to paper and the transport roller to provide the transport power of the transport roller to paper.
7	Transport roller 2 (Drive)	Transports paper fed from the paper feed tray 1 to the transport roller 3.
8	Transport roller 3	Transports paper from the transport roller 2 to the transport roller 4.
9	Paper feed roller (Manual paper feed tray)	Feeds paper to the paper transport section.
10	Separation roller (Manual paper feed tray)	Separates paper to prevent double-feeding.
11	Transport roller 4 (Idle)	Apply a pressure to paper and the transport roller to provide the transport power of the transport roller to paper.
12	Transport roller 4 (Drive)	Transports paper from the transport rollers 1 and 3 to the transport roller 5.
13	Transport roller 5 (Idle)	Apply a pressure to paper and the transport roller to provide the transport power of the transport roller to paper.
14	Transport roller 5 (Drive)	Transports paper to the registration roller. Paper is buckled between the registration roller and this roller to correct the paper skew and the relation between images and paper.
15	Registration roller (Drive)	Transports paper to the transfer section. / Controls the transport timing of paper and adjusts relative relations between the image and paper.
16	Registration roller (Idle)	Apply a pressure to paper and the registration roller to provide the transport power of the transport roller to paper.
17	Transport roller 6 (Drive)	Transports paper transported from the fusing section to the paper exit section and the switchback section.
18	Transport roller 6 (Idle)	Apply a pressure to paper and the transport roller to provide the transport power of the transport roller to paper.
19	Transport roller 7 (Idle)	Apply a pressure to paper and the transport roller to provide the transport power of the transport roller to paper.
20	Transport roller 7 (Drive)	Transports paper transported from the switchback section to the transport roller 8.
21	Transport roller 8 (Idle)	Apply a pressure to paper and the transport roller to provide the transport power of the transport roller to paper.
22	Transport roller 8 (Drive)	Transports paper transported from the transport roller 7 to the transport roller 9.
23	Transport roller 9 (Idle)	Apply a pressure to paper and the transport roller to provide the transport power of the transport roller to paper.
24	Transport roller 9 (Drive)	Transports paper transported from the transport roller 8 to the transport roller 5.
25	Paper exit roller 1 (Idle)	Apply a pressure to paper and the paper exit roller to provide the transport power of the paper exit roller to paper.
26	Paper exit roller 1 (Drive)	Transports paper to the left paper exit section.
27	Paper exit roller 2 (Idle)	Apply a pressure to paper and the paper exit roller to provide the transport power of the paper exit roller to paper.
28	Paper exit roller 2 (Drive)	Discharges paper to the right paper exit tray.
29	Fusing roller (F1)	Heats the fusing belt.
30	Fusing roller (F2)	The cushion layer of the roller forms a wide nip between the fusing belt and fusing roller (B).
31	Fusing roller (B)	Heats the back surface of paper to fuse toner on the paper.
32	Fusing web roller	Cleans the fusing roller (B) and the fusing belt.
33	Document pickup roller (RSPF)	Feeds a document to the paper feed roller.
34	Paper feed roller (RSPF)	Feeds a document to the transport section. Makes a buckle on paper between the registration roller and this roller to correct the start position of document skew and document image scan.
35	Separation roller (RSPF)	Separates a document to prevent double-feeding.
36	Transport auxiliary roller (RSPF)	Reduces friction between a document and the paper guide to transport the document smoothly to the registration roller.
37	Registration roller (Drive) (RSPF)	Transports a document to the transport roller 2. / Controls the transport timing of the document and adjusts the document scanning timing.
38	Registration roller (Idle) (RSPF)	Apply a pressure to a document and the registration roller to provide the transport power of the transport roller to the document.
39	Transport roller 2 (Idle) (RSPF)	Apply a pressure to a document and the transport roller to provide the transport power of the transport roller to the document.
40	Transport roller 2 (Drive) (RSPF)	Transports a document transported from the registration roller to the document scanning section.
41	Transport roller 3 (Idle) (RSPF)	Apply a pressure to a document and the transport roller to provide the transport power of the transport roller to the document.
42	Transport roller 3 (Drive) (RSPF)	Transports a document transported from the document scanning section to the paper exit roller.
43	Paper exit roller (Idle) (RSPF)	Apply a pressure to a document and the paper exit roller to provide the transport power of the paper exit roller to the document.
44	Paper exit roller (Drive) (RSPF)	Discharges a document. Switchbacks the document and transports it to the registration roller when scanning the back surface.
45	Transport roller 10 (Drive)	Transports paper from manual paper feed section to the transport roller 9.
46	Transport roller 10 (Idle)	Apply a pressure to paper and the transport roller to provide the transport power of the transport roller to paper.
47	Paper exit roller 3 (Drive)	Transports paper to paper exit roller 2 or transport roller 7.
48	Paper exit roller 3 (Idle)	Apply a pressure to paper and the paper exit roller to provide the transport power of the paper exit roller to paper.

## 10. Lamps

### A. 18cpm/20cpm/23cpm/31cpm(G) machine

#### (1) 18cpm/20cpm machine

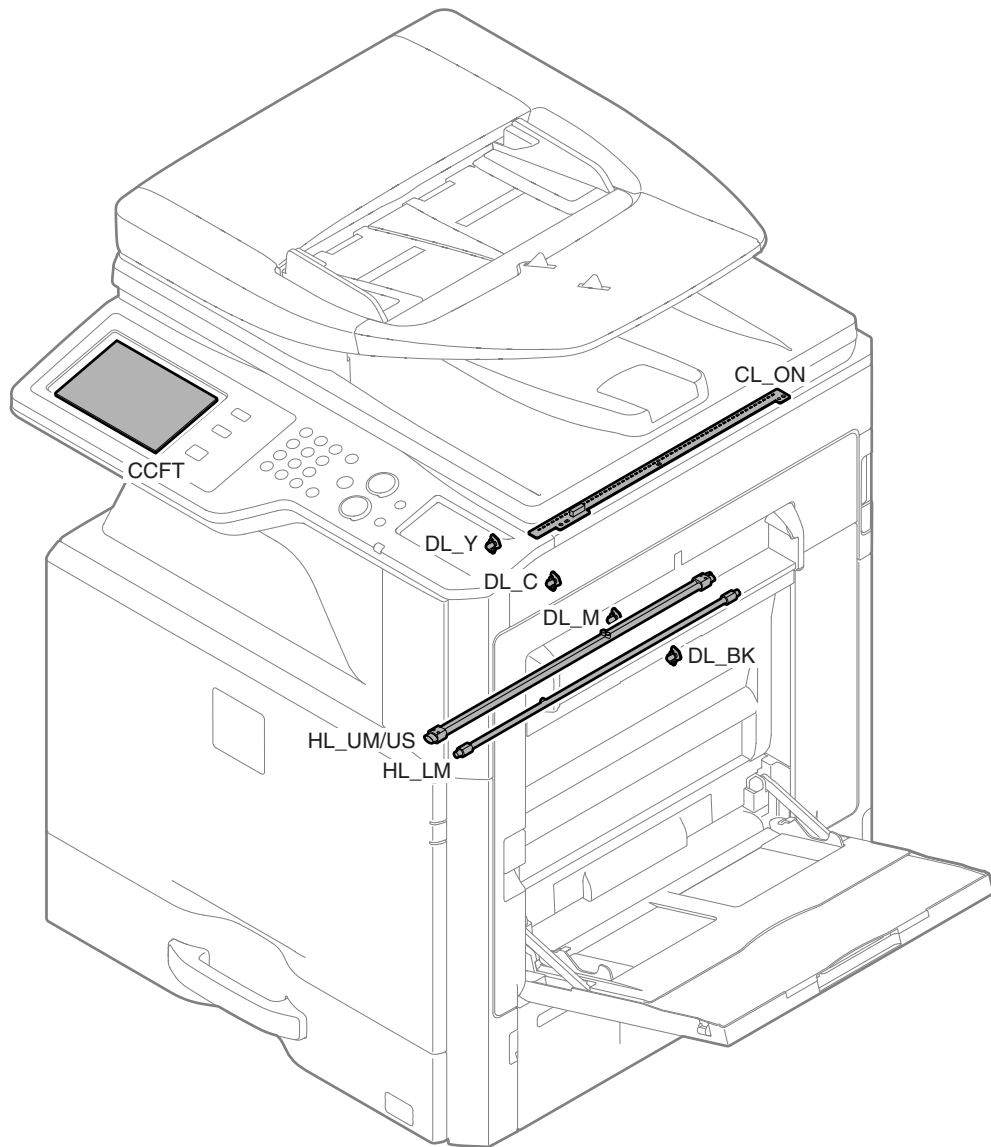

(2) 23cpm/31cpm(G) machine

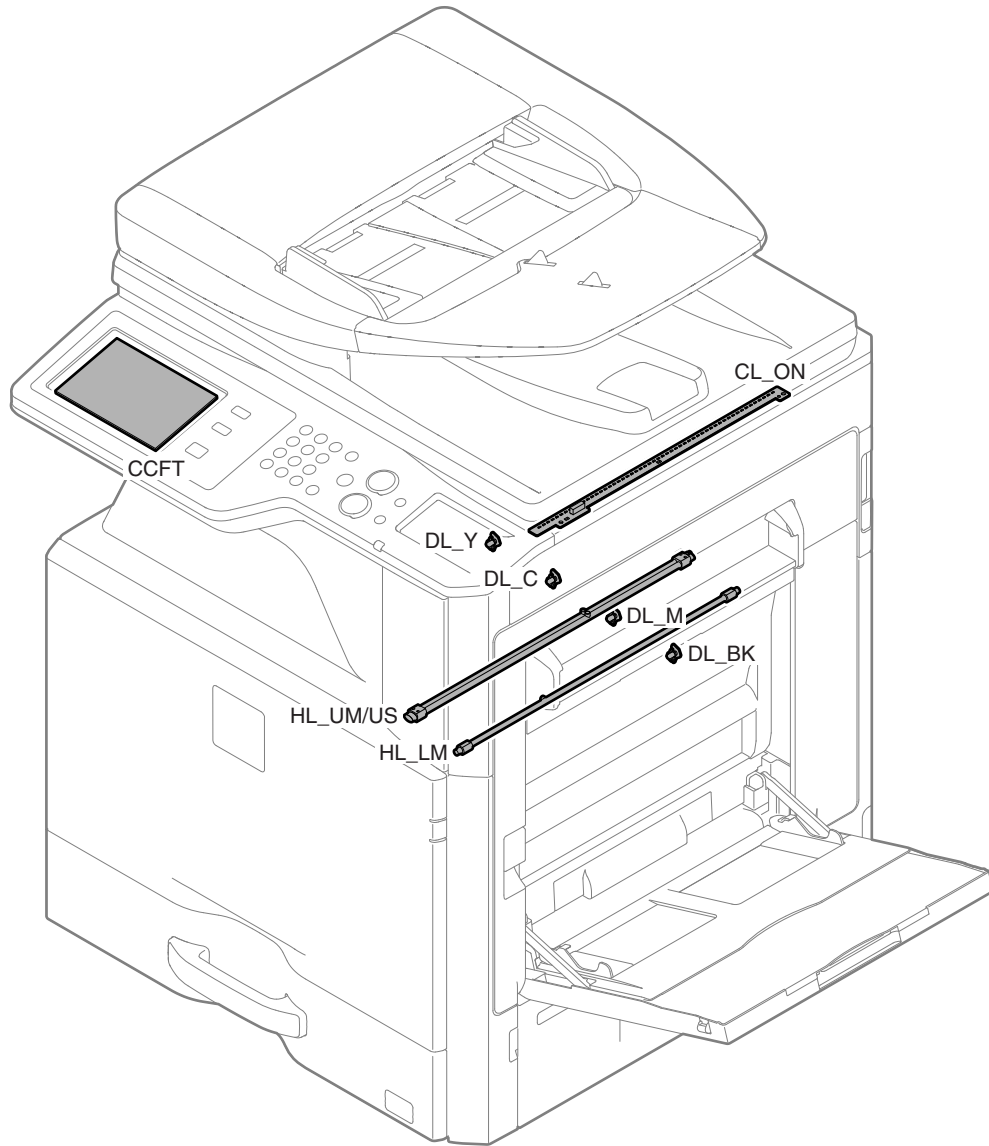

Signal name	Name	Type	Function/Operation
CCFT	LCD backlight	LED	LCD backlight
CL_ON	Scanner lamp	LED	Radiates light onto a document for the CCD to scan the document image.
DL_BK	Discharge lamp (K)	LED	Discharges electric charges on the OPC drum (K).
DL_C	Discharge lamp (C)	LED	Discharges electric charges on the OPC drum (C).
DL_M	Discharge lamp (M)	LED	Discharges electric charges on the OPC drum (M).
DL_Y	Discharge lamp (Y)	LED	Discharges electric charges on the OPC drum (Y).
HL_LM	Heater lamp (HL_LM)	Halogen lamp	Heats the fusing roller (B).
HL_UM/US	Heater lamp (HL_UM/US)	Halogen lamp	Heats the fusing roller (F1) and the fusing belt. (23cpm/26cpm/31cpm(G) machine)/ Heats the fusing roller (F). Heats the paper surface to fuse toner on the paper. (20cpm machine)

## B. 26cpm/36cpm/31cpm(A) machine

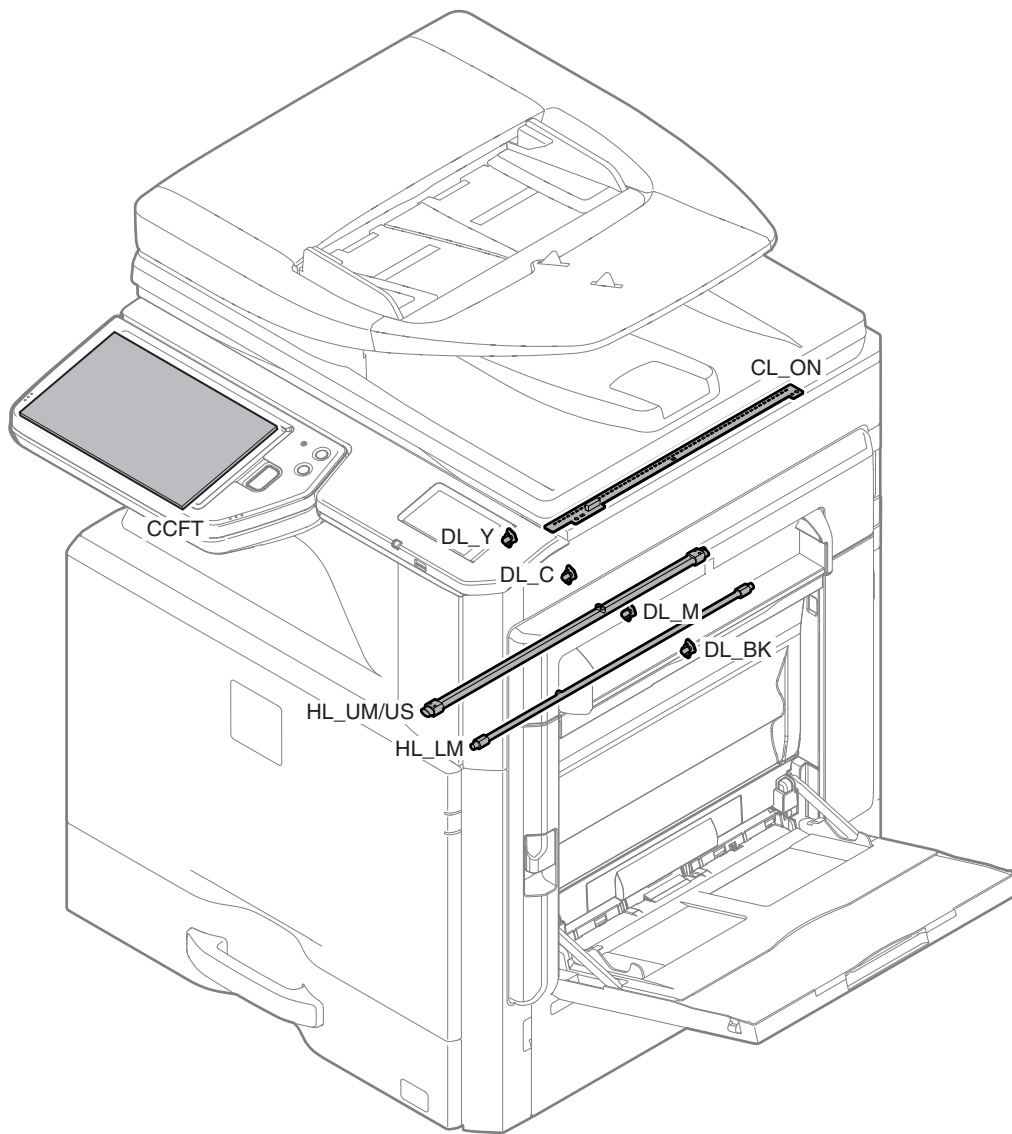

Signal name	Name	Type	Function/Operation
CCFT	LCD backlight	LED	LCD backlight
CL_ON	Scanner lamp	LED	Radiates light onto a document for the CCD to scan the document image.
DL_BK	Discharge lamp (K)	LED	Discharges electric charges on the OPC drum (K).
DL_C	Discharge lamp (C)	LED	Discharges electric charges on the OPC drum (C).
DL_M	Discharge lamp (M)	LED	Discharges electric charges on the OPC drum (M).
DL_Y	Discharge lamp (Y)	LED	Discharges electric charges on the OPC drum (Y).
HL_LM	Heater lamp (HL_LM)	Halogen lamp	Heats the fusing roller (B).
HL_UM/US	Heater lamp (HL_UM/US)	Halogen lamp	Heats the fusing roller (F1) and the fusing belt.

## 11. Fans and filter

### A. 18cpm/20cpm/23cpm/26cpm/31cpm machine

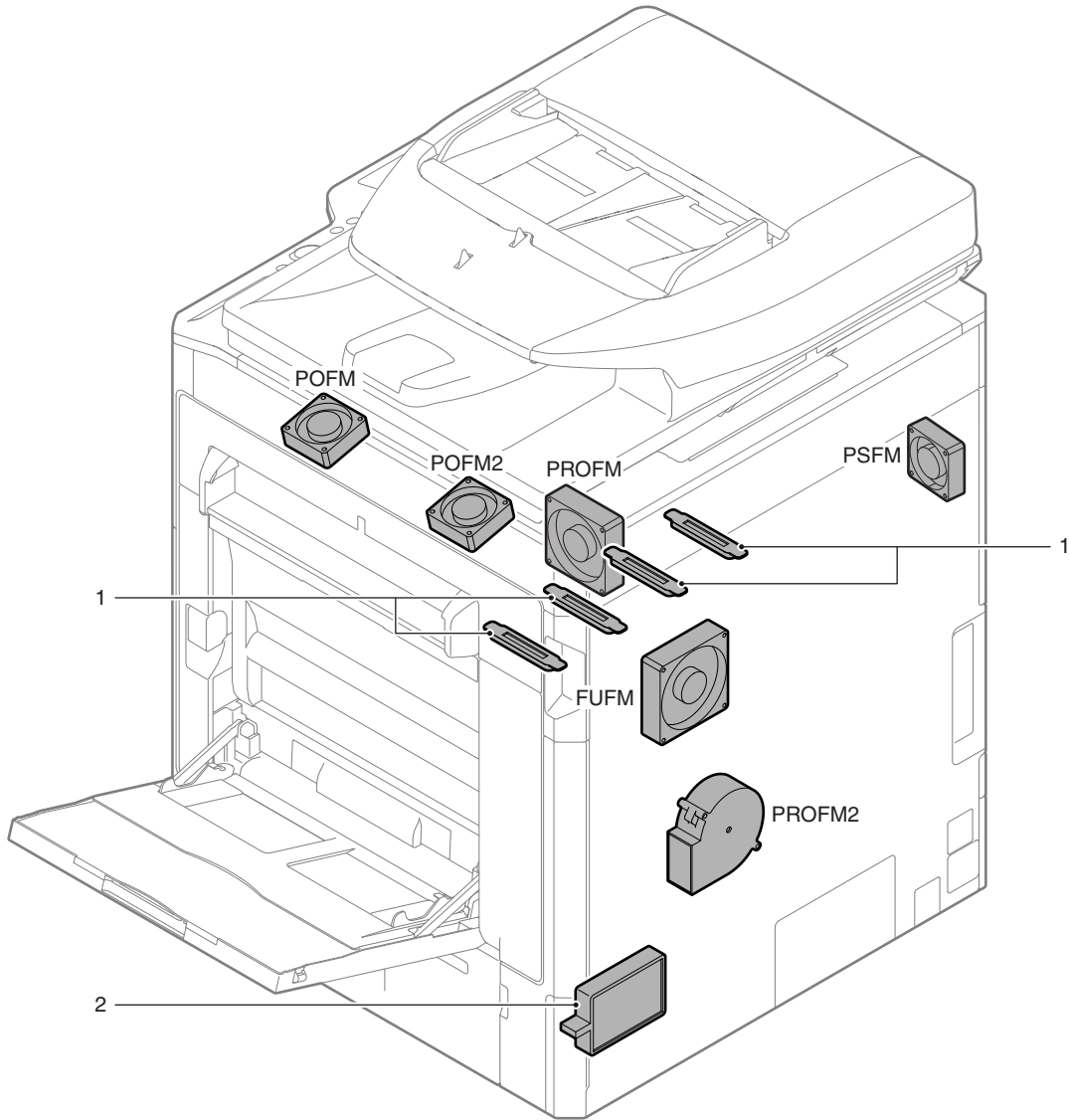

Signal name	Name	Function/Operation
FUFM	Fusing cooling fan	Cools the fusing section and the paper exit section.
POFM	Paper exit cooling fan	Cools the fusing section and the paper exit section.
POFM2	Paper exit cooling fan	Cools the fusing section and the paper exit section.
PROFM	Process fan motor 1	Discharges air and cools the process section.
PROFM2	Process fan motor 2	Discharges air and cools the process section.
PSFM	Power cooling fan motor	Cools the power unit.

No.	Name	Function/Operation
1	Toner filter	Prevents toner splash.
2	Ozone filter	Absorbs ozone generated in the image process section.

## B. 36cpm machine

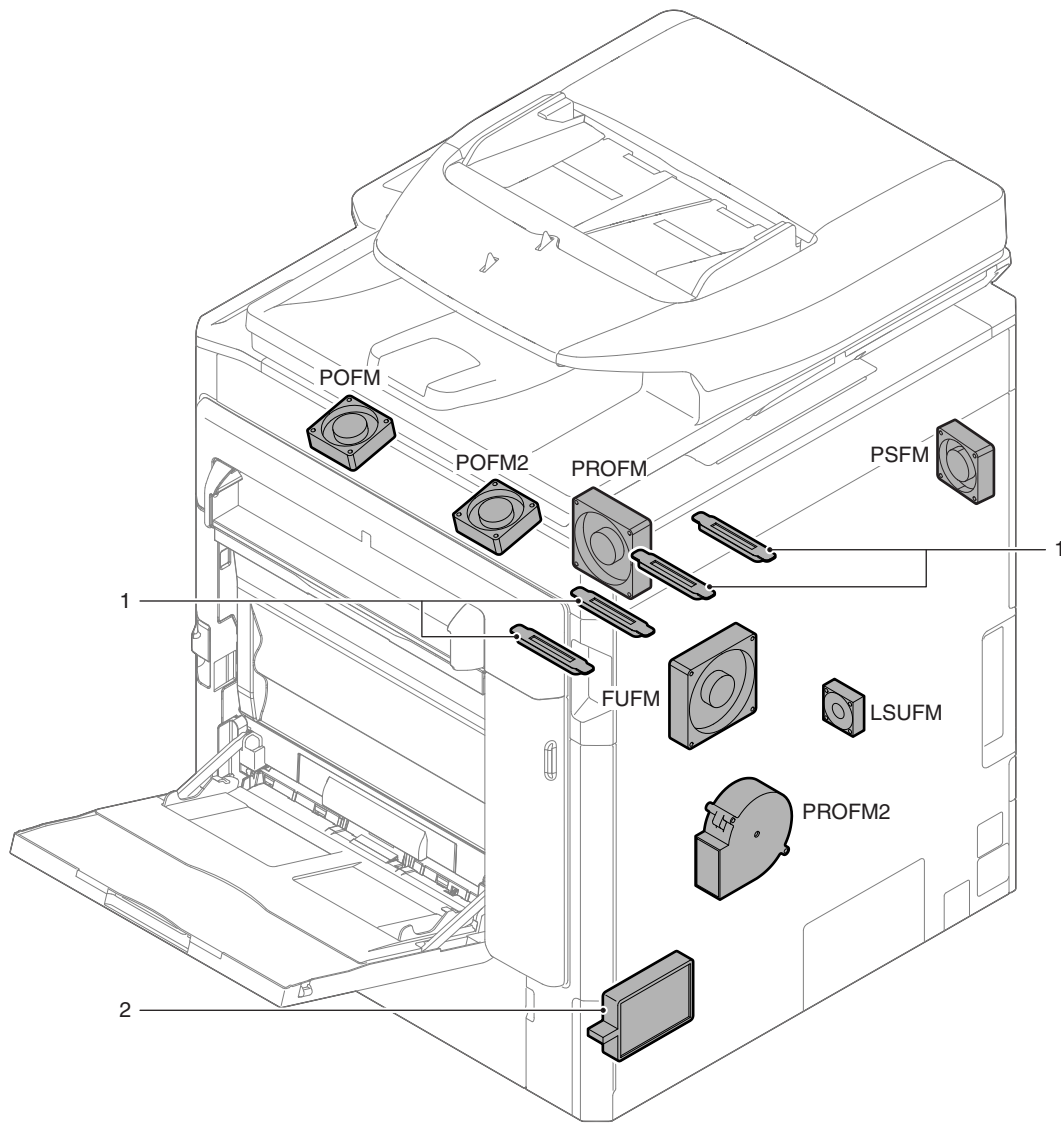

Signal name	Name	Function/Operation
FUFM	Fusing cooling fan	Cools the fusing section and the paper exit section.
LSUFM	LSU cooling fan	Cools the LSU.
POFM	Paper exit cooling fan	Cools the fusing section and the paper exit section.
POFM2	Paper exit cooling fan	Cools the fusing section and the paper exit section.
PROFM	Process fan motor 1	Discharges air and cools the process section.
PROFM2	Process fan motor 2	Discharges air and cools the process section.
PSFM	Power cooling fan motor	Cools the power unit.

No.	Name	Function/Operation
1	Toner filter	Prevents toner splash.
2	Ozone filter	Absorbs ozone generated in the image process section.

## 12. Gates

### A. 18cpm/20cpm/23cpm/26cpm/31cpm machine

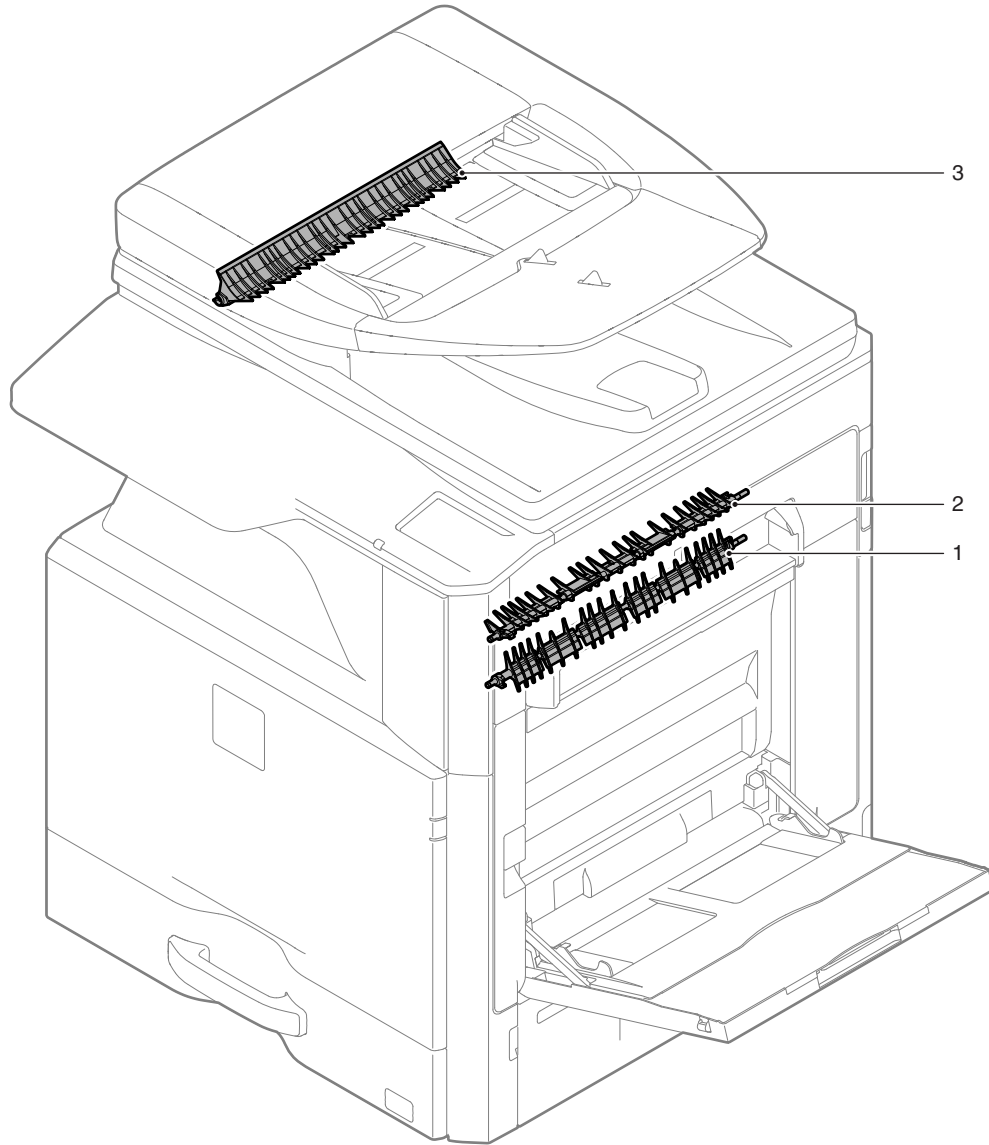

No.	Name	Function/Operation
1	Switchback gate	Switchbacks paper to transport it to the ADU section.
2	Paper exit gate	Switchbacks paper to transport it to the right paper exit tray.
3	Document reverse gate	Reverses a document when scanning images on the back surface.



**B. 36cpm machine**

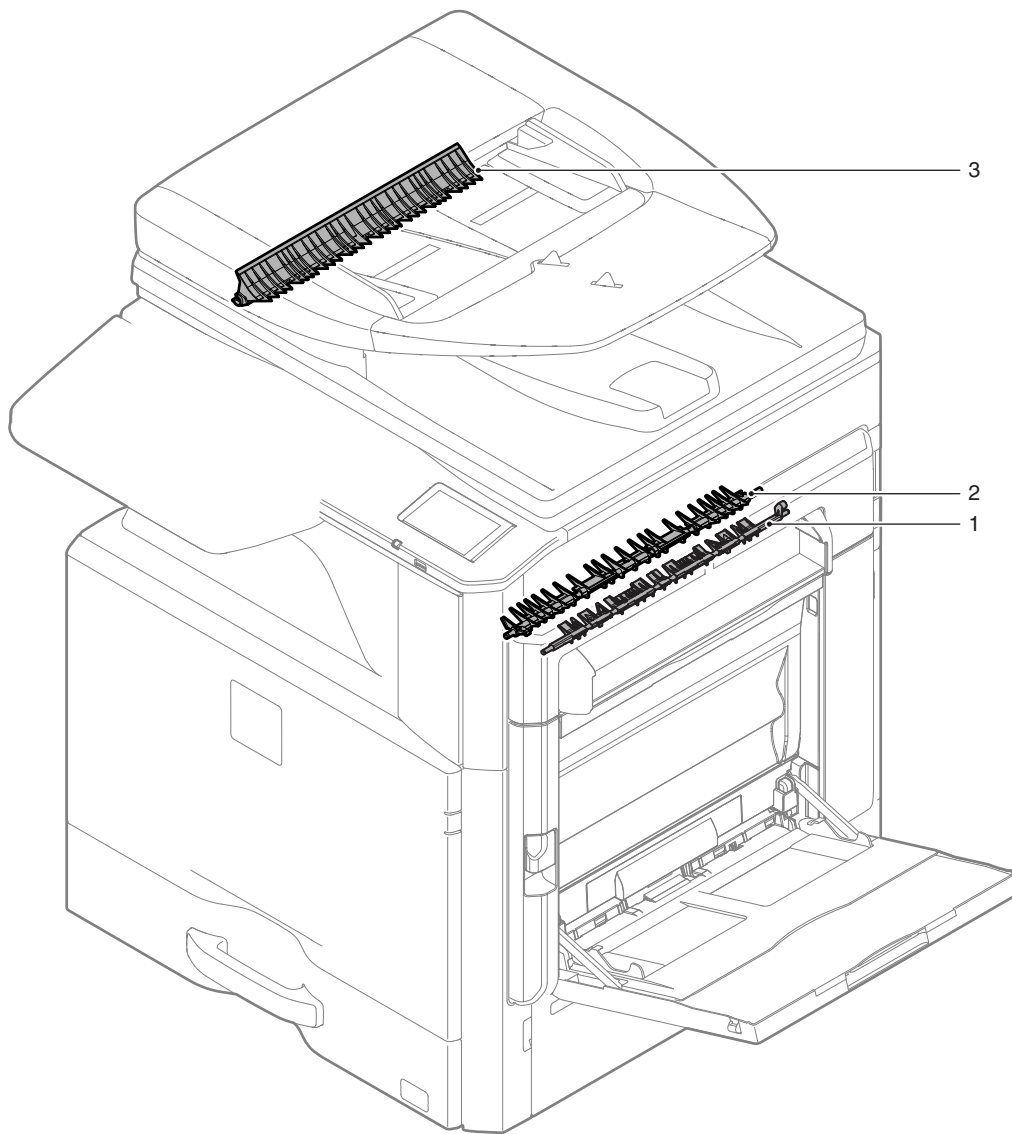

No.	Name	Function/Operation
1	Switchback gate	Switchbacks paper to transport to the ADU section or the right paper exit tray.
2	Paper exit gate	Selects the paper path: to transport paper to the ADU section or to the right tray.
3	Document reverse gate	Reverses a document when scanning images on the back surface.

## 13. Heater

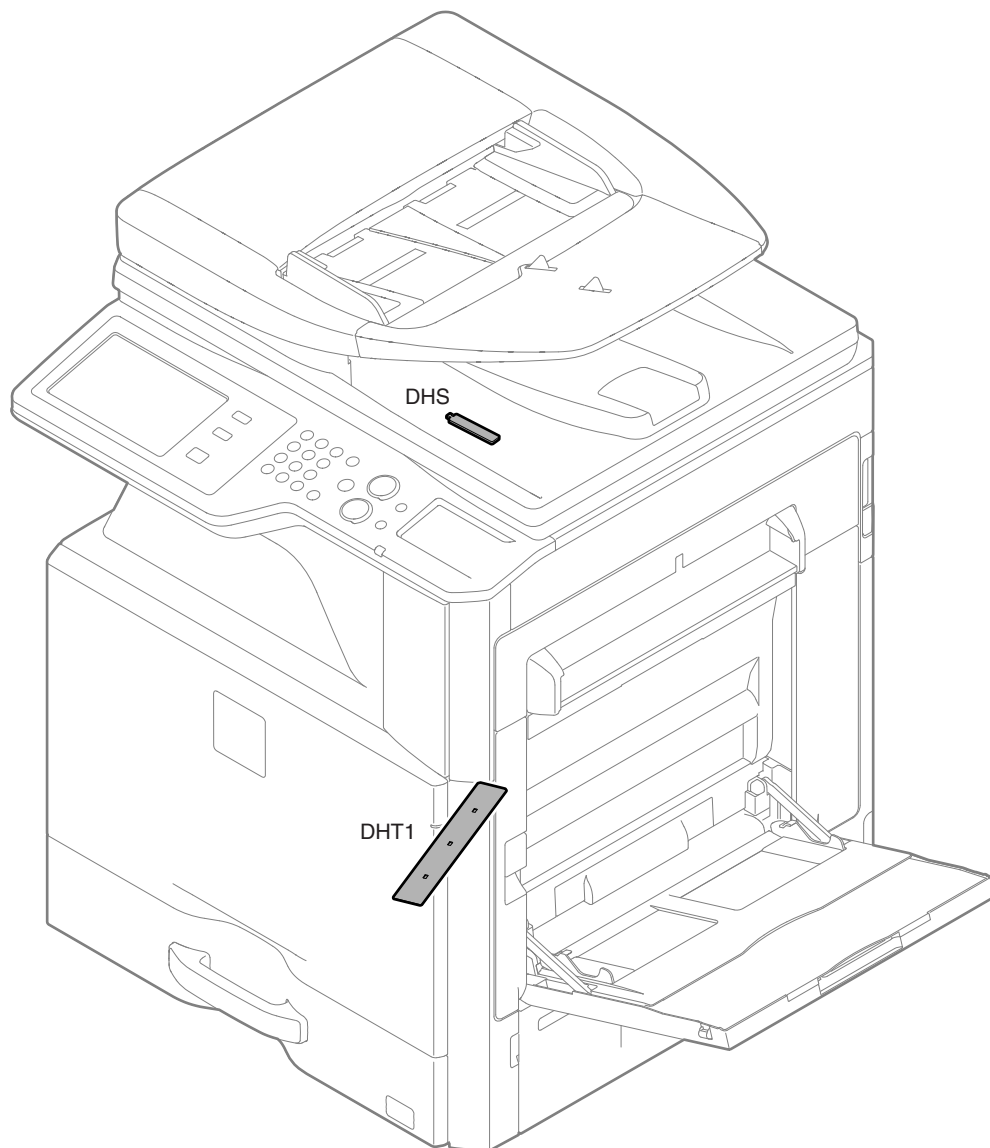

Signal name	Name	Function/Operation
DHS	Scanner dehumidifying heater	Dehumidifies the scanner section to prevent it from dew condensation.
DHT1	Paper dehumidifying heater (Paper feed tray 1)	Dehumidifies the paper feed tray section to prevent paper from absorbing humidity which causes degraded image quality and paper jams.

# 14. PWB/Memory device

## A. 18cpm/20cpm/23cpm/31cpm(G) machine

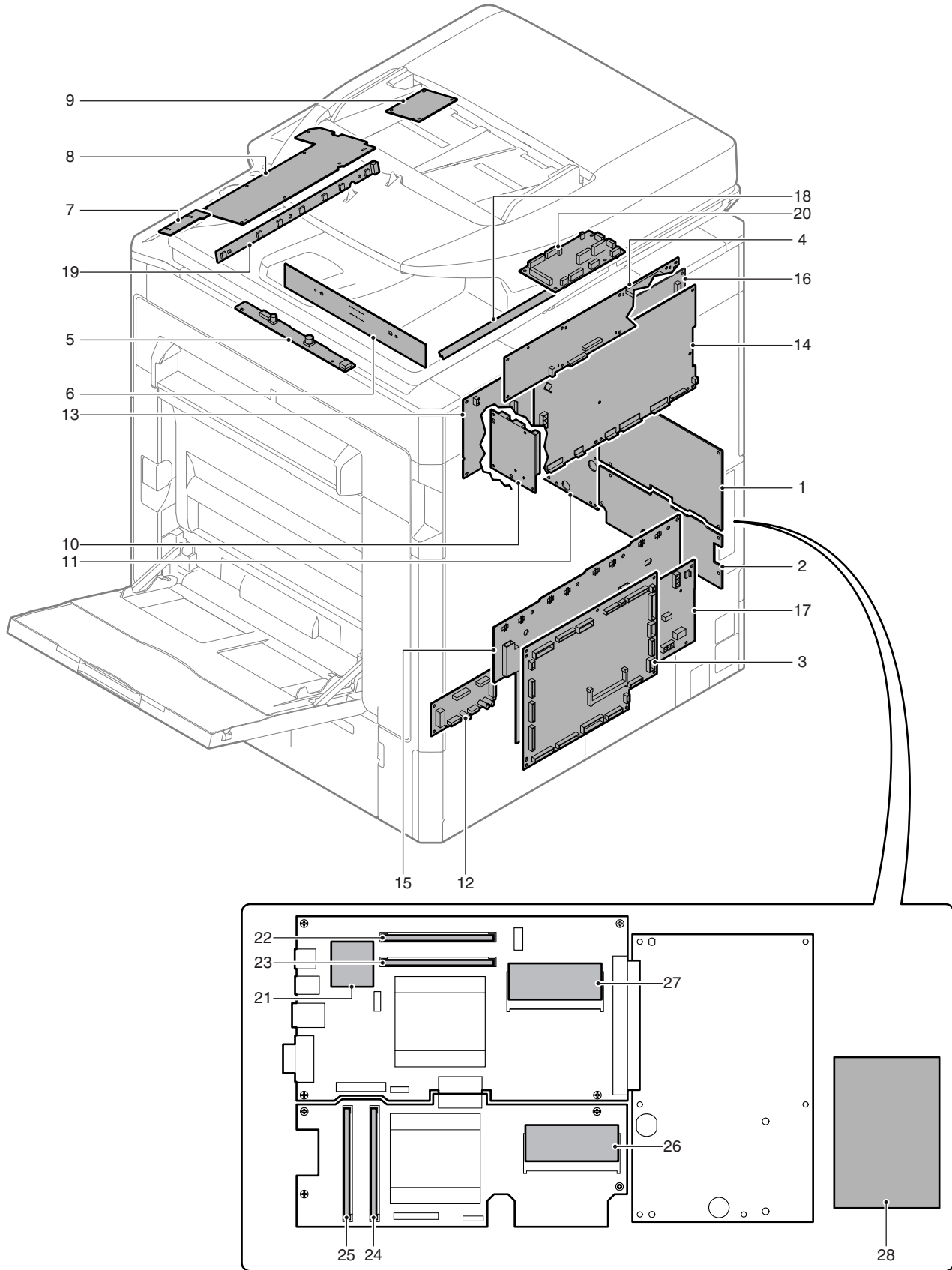

No.	Name	Function/Operation
1	MFP control PWB	Controls image data (compression, decompression, and filing), and controls the whole machine.
2	Printer control PWB	Converts print data (PCL/PS) into image data.
3	PCU PWB	Controls the engine section.
4	SCU PWB	Controls the scanner and the operation section.
5	Scanner lamp drive PWB	Drives the scanner lamp
6	CCD PWB	Scans document images and performs A/D conversion of the scanning signal.
7	USB I/F PWB	USB I/F
8	KEY PWB	Outputs the key operation signal.
9	LVDS PWB	Converts the display data signal to the LCD display signal. Controls the touch panel.
10	LD PWB	Drives the laser diode and controls the power.
11	LSU mother PWB	Controls the LSU. Generates the video data. Interfaces the MFP PWB, the scanner control PWB, the operation PWB, the PCU PWB, and the FAX unit.
12	Driver PWB	Drives the motor.
13	HL control PWB	Drives the heater lamp.
14	DC POWER PWB	Generates the DC voltage.
15	High voltage PWB (MC/DV PWB)	Generates the main charger voltage and the DV bias voltage.
16	High voltage PWB (TC PWB)	Generates the transfer voltage.
17	Dehumidifier heater control PWB	Controls the dehumidifier heater.
18	Document size detection PWB (Light emitting)	Drives the LED for the document size detection.
19	Document size detection PWB (Light receiving)	Outputs the document size detection signal.
20	RSPF driver PWB	Drives the motor, the solenoid, and the clutch in the RSPF section.
21	SD card memory	Stores the MFP PWB program data, the FAX image data, and the font data.
22	DIMM memory 1	Image memory for the MFP PWB
23	DIMM memory 2	Not used.
24	DIMM memory 3	Memory for the printer
25	DIMM memory 4	Memory for the XPS printer
26	Printer Flash memory	Stores the printer program data.
27	DSK Flash memory	Stores the DSK program data.
28	HDD	Stores the MFP PWB program data, the filing data, the e-manual data, the watermark data, the log data, and the authentication data. Also used as a work memory.

**B. 26cpm/31cpm(A) machine**

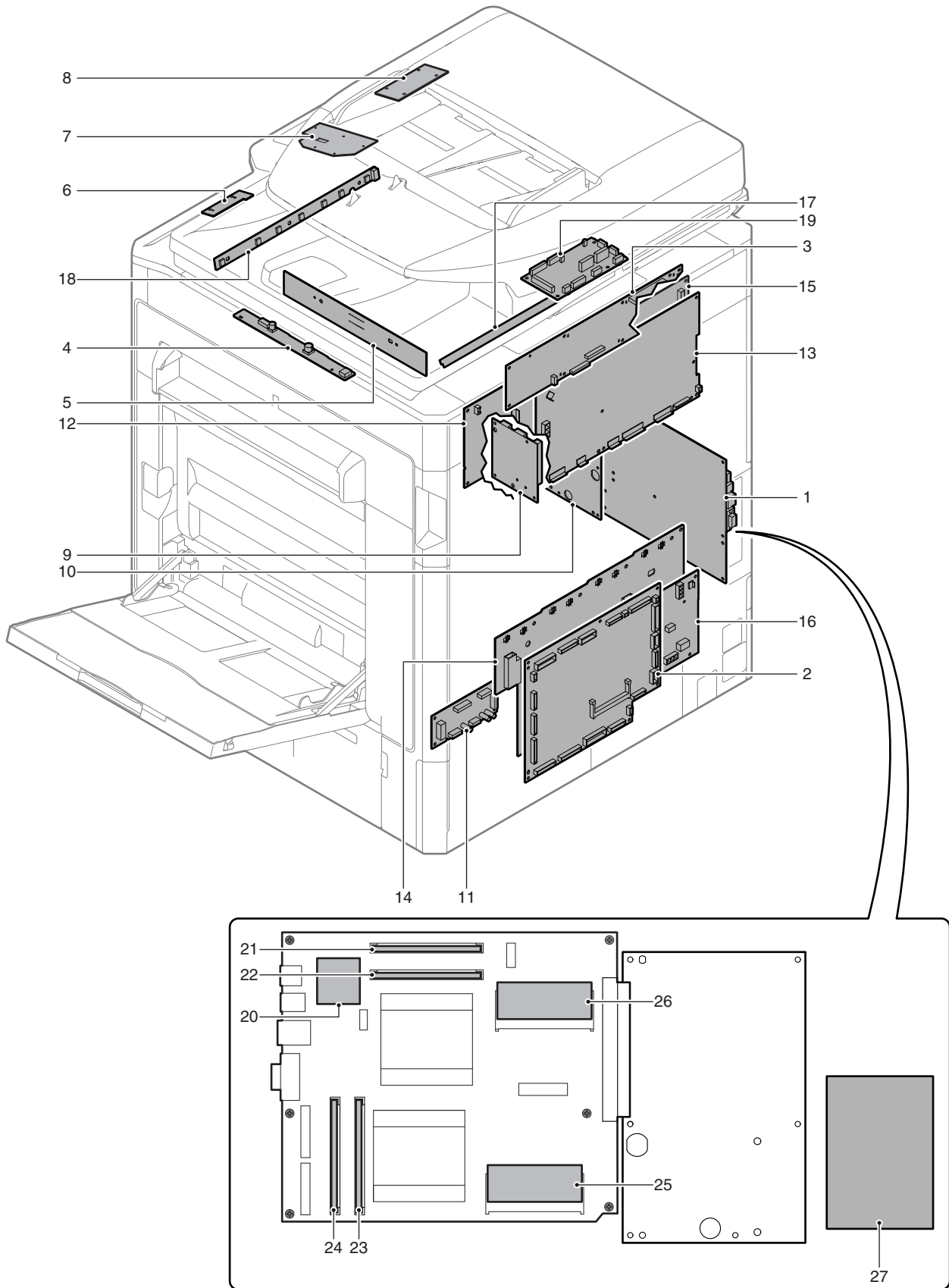

No.	Name	Function/Operation
1	MFP control PWB	Controls image data (compression, decompression, and filing), and controls the whole machine. Converts print data (PCL/PS) into image data.
2	PCU PWB	Controls the engine section.
3	SCU PWB	Controls the scanner and the operation section.
4	Scanner lamp drive PWB	Drives the scanner lamp
5	CCD PWB	Scans document images and performs A/D conversion of the scanning signal.
6	USB I/F PWB	USB I/F
7	KEY PWB	Outputs the key operation signal.
8	LVDS PWB	Converts the display data signal to the LCD display signal. Controls the touch panel.
9	LD PWB	Drives the laser diode and controls the power.
10	LSU mother PWB	Controls the LSU. Generates the video data. Interfaces the MFP PWB, the scanner control PWB, the operation PWB, the PCU PWB, and the FAX unit.
11	Driver PWB	Drives the motor.
12	HL control PWB	Drives the heater lamp.
13	DC POWER PWB	Generates the DC voltage.
14	High voltage PWB (MC/DV PWB)	Generates the main charger voltage and the DV bias voltage.
15	High voltage PWB (TC PWB)	Generates the transfer voltage.
16	Dehumidifier heater control PWB	Controls the dehumidifier heater.
17	Document size detection PWB (Light emitting)	Drives the LED for the document size detection.
18	Document size detection PWB (Light receiving)	Outputs the document size detection signal.
19	RSPF driver PWB	Drives the motor, the solenoid, and the clutch in the RSPF section.
20	SD card memory	Stores the MFP PWB program data, the FAX image data, and the font data.
21	DIMM memory 1	Image memory for the MFP PWB
22	DIMM memory 2	Not used.
23	DIMM memory 3	Memory for the printer
24	DIMM memory 4	Memory for the XPS printer
25	Printer Flash memory	Stores the printer program data.
26	DSK Flash memory	Stores the DSK program data.
27	HDD	Stores the MFP PWB program data, the filing data, the e-manual data, the watermark data, the log data, and the authentication data. Also used as a work memory.

C. 36cpm machine

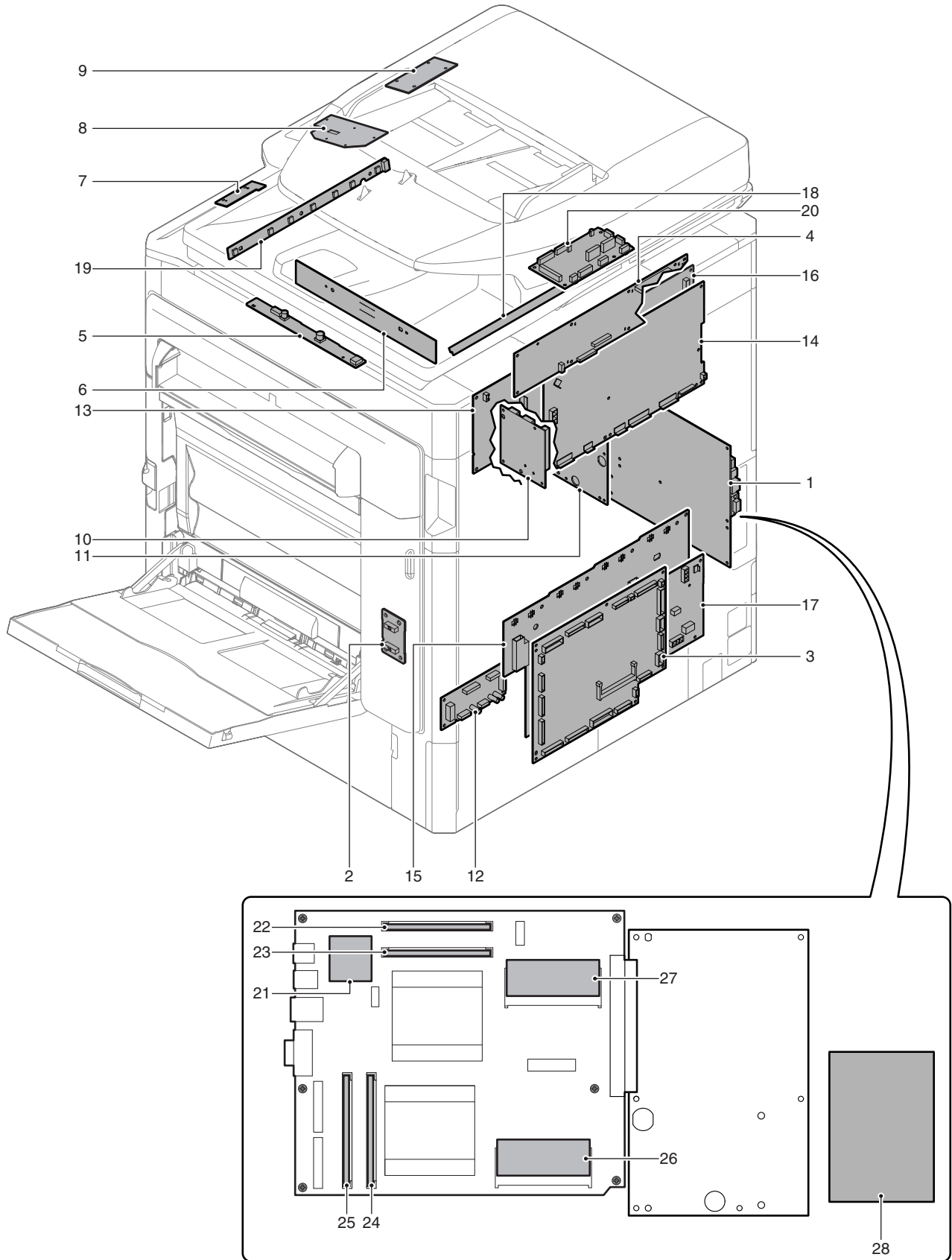

No.	Name	Function/Operation
1	MFP control PWB	Controls image data (compression, decompression, and filing), and controls the whole machine. Converts print data (PCL/PS) into image data.
2	Right door PWB	Interfaces the right door unit signal.
3	PCU PWB	Controls the engine section.
4	SCU PWB	Controls the scanner and the operation section.
5	Scanner lamp drive PWB	Drives the scanner lamp
6	CCD PWB	Scans document images and performs A/D conversion of the scanning signal.
7	USB I/F PWB	USB I/F
8	KEY PWB	Outputs the key operation signal.
9	LVDS PWB	Converts the display data signal to the LCD display signal. Controls the touch panel.
10	LD PWB	Drives the laser diode and controls the power.
11	LSU mother PWB	Controls the LSU. Generates the video data. Interfaces the MFP PWB, the scanner control PWB, the operation PWB, the PCU PWB, and the FAX unit.
12	Driver PWB	Drives the motor.
13	HL control PWB	Drives the heater lamp.
14	DC POWER PWB	Generates the DC voltage.
15	High voltage PWB (MC/DV PWB)	Generates the main charger voltage and the DV bias voltage.
16	High voltage PWB (TC PWB)	Generates the transfer voltage.
17	AC POWER PWB	Controls the primary side power.
18	Document size detection PWB (Light emitting)	Drives the LED for the document size detection.
19	Document size detection PWB (Light receiving)	Outputs the document size detection signal.
20	RSPF driver PWB	Drives the motor, the solenoid, and the clutch in the RSPF section.
21	SD card memory	Stores the MFP PWB program data, the FAX image data, and the font data.
22	DIMM memory 1	Image memory for the MFP PWB
23	DIMM memory 2	Not used.
24	DIMM memory 3	Memory for the printer
25	DIMM memory 4	Memory for the XPS printer
26	Printer Flash memory	Stores the printer program data.
27	DSK Flash memory	Stores the DSK program data.
28	HDD	Stores the MFP PWB program data, the filing data, the e-manual data, the watermark data, the log data, and the authentication data. Also used as a work memory.



## 15. Fuses and Thermostats

### A. 18cpm/20cpm/23cpm/26cpm/31cpm machine

#### (1) 18cpm/20cpm machine

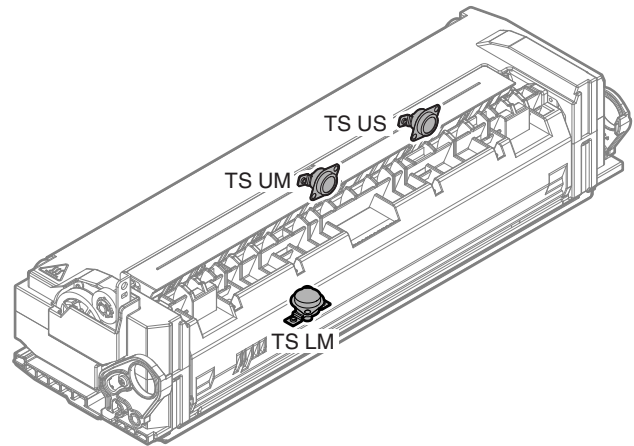
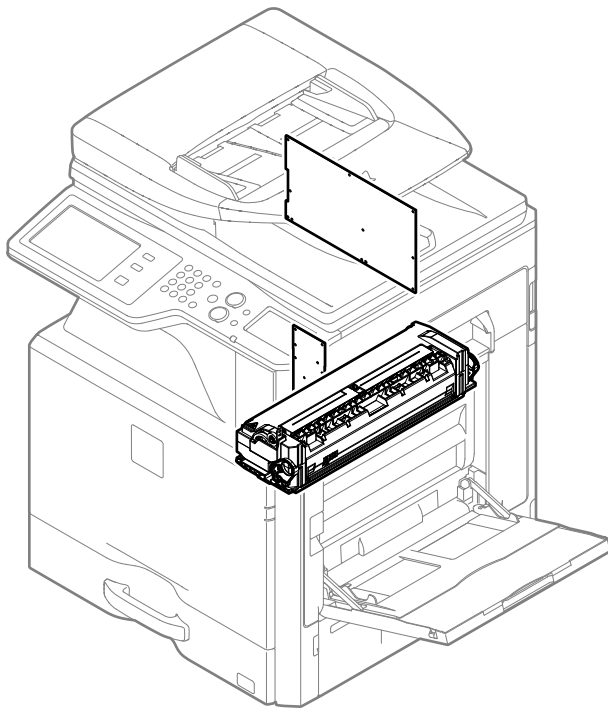
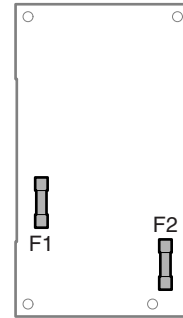
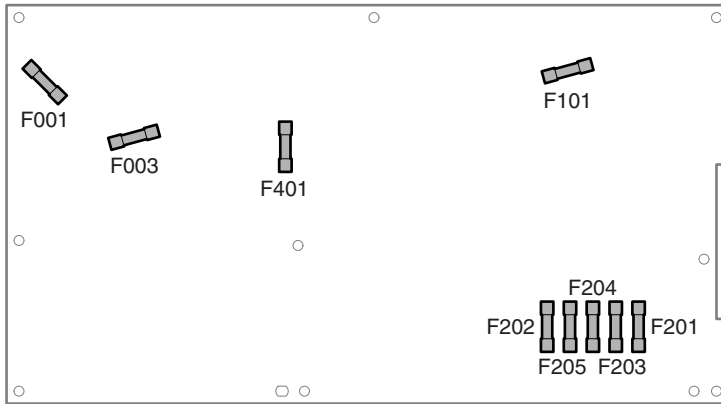

(2) 23cpm/26cpm/31cpm machine

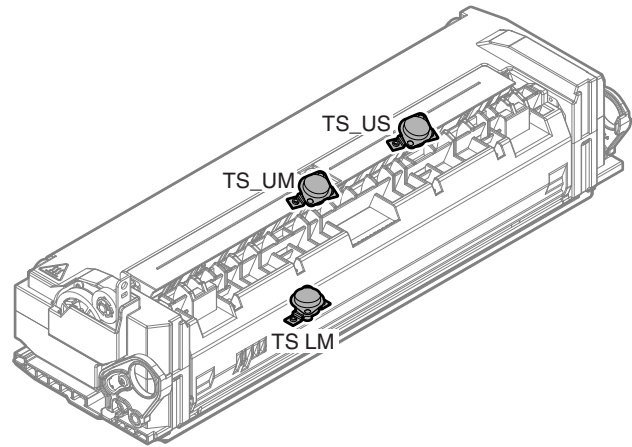
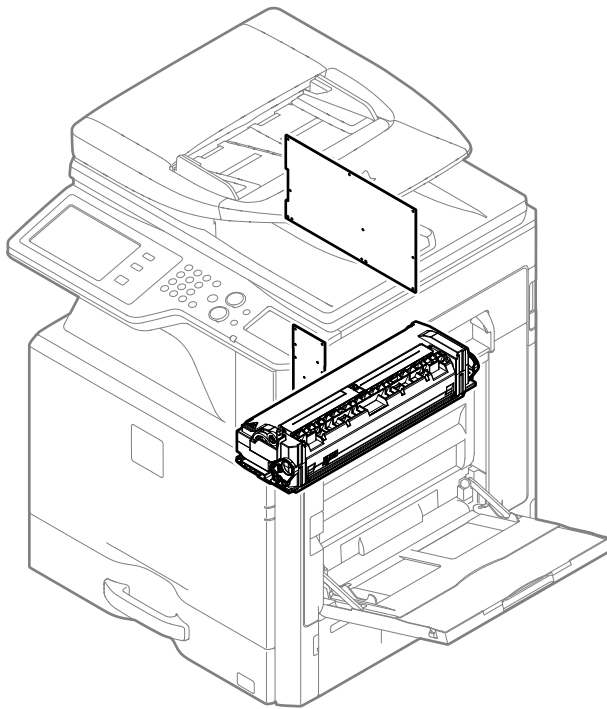
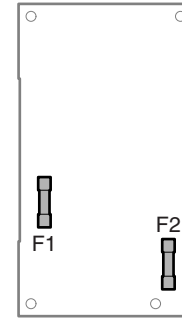
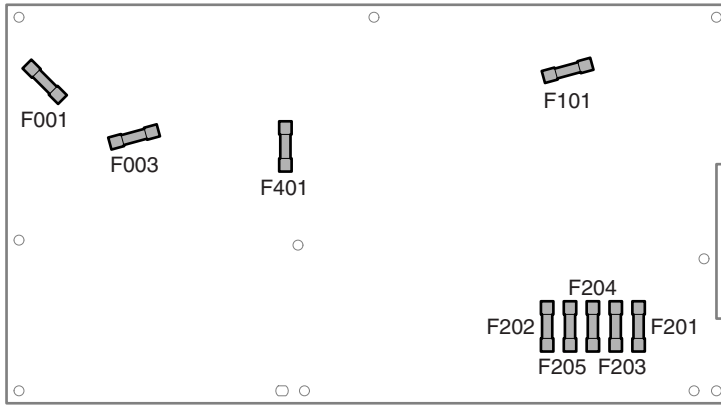

Signal name	Name	100v series	200v series	Section
F1	Fuse	20A 250V	T10AH 250V	AC Power PWB
F2	Fuse	-	T10AH 250V	AC Power PWB
F001	Fuse	T12AH 250V	T6.3AH 250V	DC Power PWB
F003	Fuse	T3.15AH 250V	T3.15AH 250V	DC Power PWB
F101	Fuse	F10AH 250V (F101)	F5AH 250V (F101)	DC Power PWB
F401	Fuse	F3.15AH 250V (F401)	F2AH 250V (F401)	DC Power PWB
F201	Fuse	6.3A	6.3A	DC Power PWB
F202	Fuse	6.3A	6.3A	DC Power PWB
F203	Fuse	6.3A	6.3A	DC Power PWB
F204	Fuse	6.3A	6.3A	DC Power PWB
F205	Fuse	4.0A	4.0A	DC Power PWB

Signal name	Name	Type	Function/Operation
TS LM	Thermostat LM	Mechanical thermostat	Shuts down the heater lamp (HL_LM) circuit when the fusing section is overheated.
TS UM	Thermostat UM	Mechanical thermostat	Shuts down the heater lamp (HL_UM) circuit when the fusing section is overheated. (Center section)
TS US	Thermostat US	Mechanical thermostat	Shuts down the heater lamp (HL_US) circuit when the fusing section is overheated. (Edge section)

## B. 36cpm machine

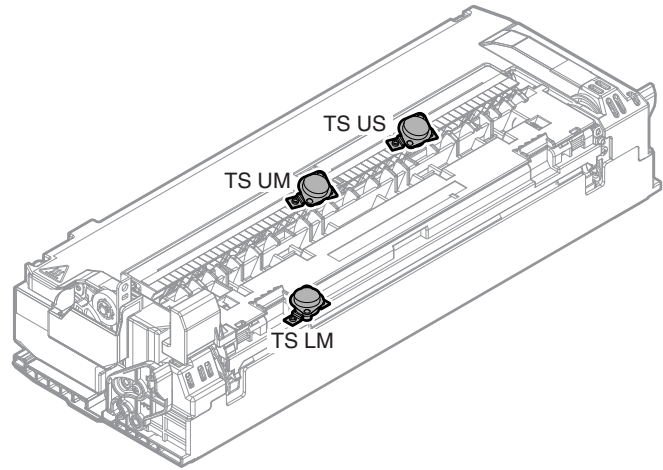
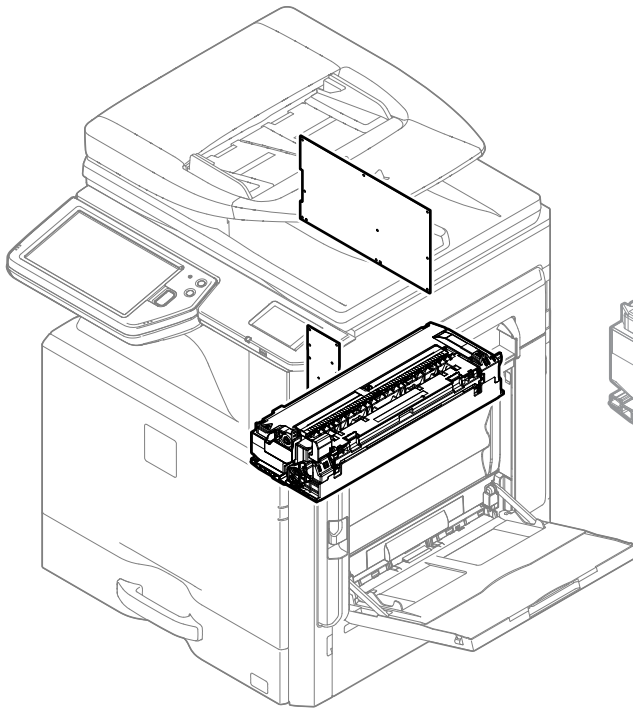
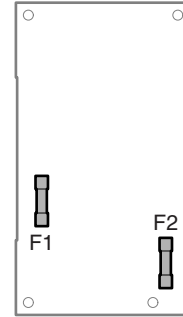
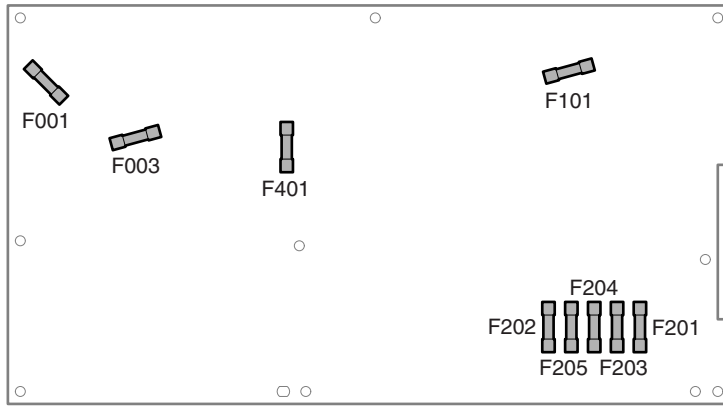

Signal name	Name	100v series	200v series	Section
F1	Fuse	20A 250V	T10AH 250V	AC Power PWB
F2	Fuse	-	T10AH 250V	AC Power PWB
F001	Fuse	T12AH 250V	T6.3AH 250V	DC Power PWB
F003	Fuse	T3.15AH 250V	T3.15AH 250V	DC Power PWB
F101	Fuse	F10AH 250V (F101)	F5AH 250V (F101)	DC Power PWB
F401	Fuse	F3.15AH 250V (F401)	F2AH 250V (F401)	DC Power PWB
F201	Fuse	6.3A	6.3A	DC Power PWB
F202	Fuse	6.3A	6.3A	DC Power PWB
F203	Fuse	6.3A	6.3A	DC Power PWB
F204	Fuse	6.3A	6.3A	DC Power PWB
F205	Fuse	4.0A	4.0A	DC Power PWB

Signal name	Name	Type	Function/Operation
TS LM	Thermostat LM	Mechanical thermostat	Shuts down the heater lamp (HL_LM) circuit when the fusing section is overheated.
TS UM	Thermostat UM	Mechanical thermostat	Shuts down the heater lamp (HL_UM) circuit when the fusing section is overheated. (Center section)
TS US	Thermostat US	Mechanical thermostat	Shuts down the heater lamp (HL_US) circuit when the fusing section is overheated. (Edge section)

## 16. Lock

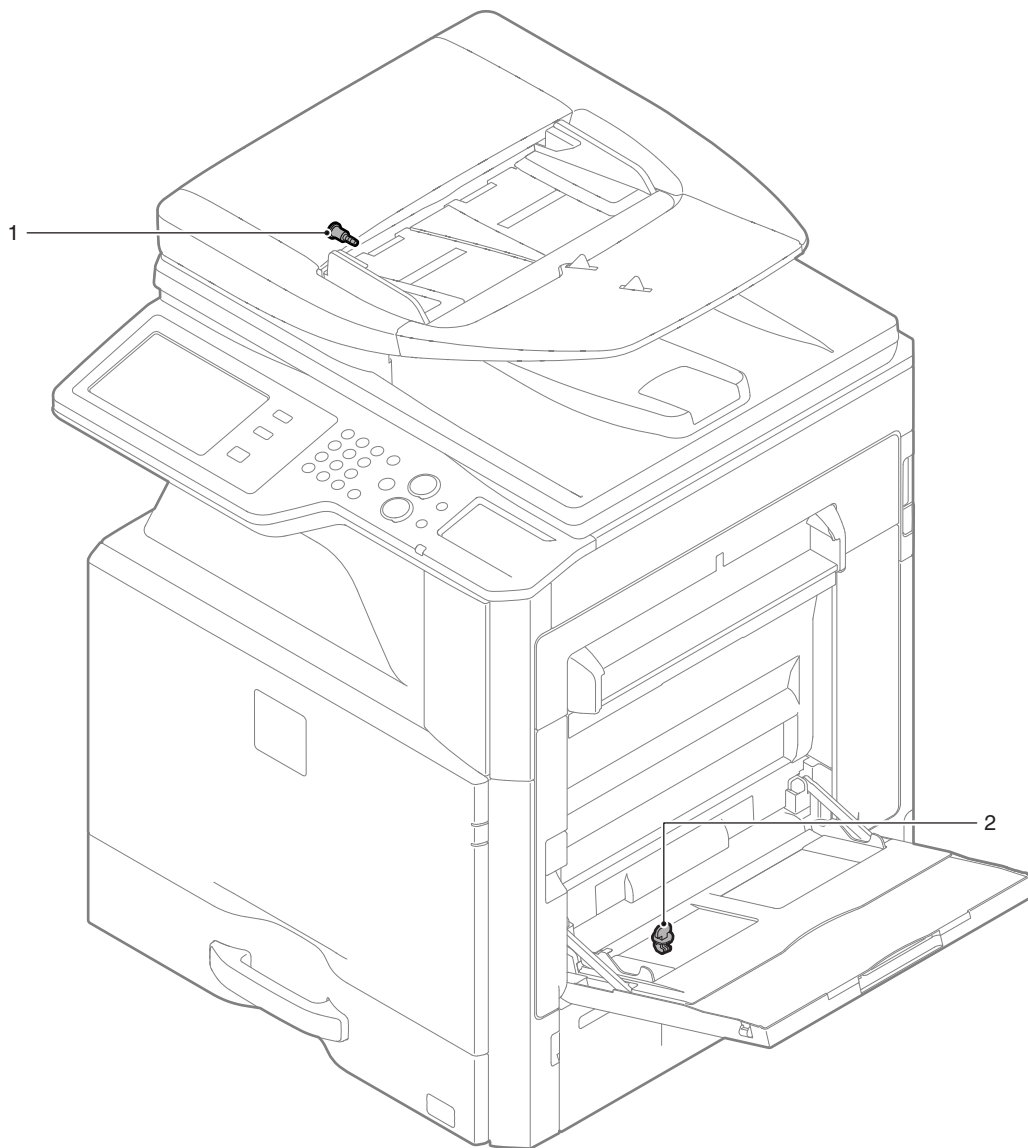

No.	Name	Function/Operation
1	Scanner lock	Fixes the scanner during transit.
2	Paper feed tray lift plate lock	Fixes the paper feed tray lift plate during transit.

## [4] ADJUSTMENTS AND SETTINGS

### 1. General

Each adjustment item in the adjustment item list is associated with a specific Job number. Perform the adjustment procedures in the sequence of Job numbers from the smallest to the greatest.

However, there is no need to perform all the adjustment items. Perform only the necessary adjustments according to the need.

Unnecessary adjustments can be omitted. Even in this case, however, the sequence from the smallest to the greatest Job number must be observed.

If the above precaution should be neglected, the adjustment would not complete normally or trouble may occur.

### 2. Adjustment item list

Job No.	Adjustment item list			Simulation		
ADJ 1	Adjust the developing unit	1A	Adjust the developing doctor gap			
		1B	Adjust the developing roller main pole position			
		1C	Toner density control reference value setting	25-2		
ADJ 2	Adjusting high voltage values	2A	Adjust the main charger grid voltage	8-2		
		2B	Adjust the developing bias voltage	8-1		
		2C	Transfer current and voltage adjustment	8-6		
ADJ 3	Image density sensor adjustment	3A	Image density sensor calibration	44-13		
		3B	Image density sensor adjustment	44-2		
ADJ 4	Image lead edge position, image loss, void area, image off-center, image magnification ratio adjustment (Automatic adjustment)	4A	Print image main scanning direction automatic magnification ratio adjustment (Print engine)	50-28		
		4B	Print image off-center automatic adjustment (Print engine) (Each paper feed tray)	50-28		
		4C	Copy mode image lead edge position, image loss, void area, image off-center, sub scanning direction image magnification ratio automatic adjustment (Scanner) (Document table mode)	50-28		
		4D	Copy mode image lead edge position, image loss, void area, image off-center, sub scanning direction image magnification ratio automatic adjustment (Scanner) (RSPF mode)	50-28		
ADJ 5	Print engine image distortion adjustment / OPC drum phase adjustment / Color registration adjustment (Print engine section)	5A	Print engine image distortion adjustment (Manual adjustment) / OPC drum phase adjustment (Automatic adjustment) / Color registration adjustment (Automatic adjustment)	50-22		
		5B	Print engine image skew (LSU skew) adjustment (Manual adjustment) (No need to adjust normally)	50-20 (64-1)		
		5C	Color registration offset adjustment (No need to adjust normally)	50-20		
ADJ 6	Scan image distortion adjustment (Document table mode)	6A	Scanner (reading) unit parallelism adjustment			
		6B	Scan image (sub scanning direction) distortion adjustment			
		6C	Scan image (main scanning direction) distortion adjustment			
ADJ 7	Scanner image skew adjustment (RSPF mode)			64-2		
ADJ 8	Scan image focus adjustment			48-1		
ADJ 9	Print lead edge image position adjustment (Printer mode)			50-5		
ADJ 10/ SET1	Color balance and density adjustment		Note before execution of the image quality adjustment			
			Copy image quality check			
			Printer image quality check			
		10A	Scanner calibration (CCD calibration)		63-3 (63-5)	
		SET 1	Color balance adjustment target setup	1A	Copy color balance adjustment target setup	63-7/8/11
				1B	Printer color balance adjustment target setup	67-26/27/28
		10B	Copy/Printer color balance and density adjustment (Automatic adjustment) (Basic adjustment)		46-74	
		10C	Copy image quality adjustment (Basic adjustment)	10C (1)	Copy color balance and density adjustment (Automatic adjustment)	46-24
				10C (2)	Copy color balance and density adjustment (Manual adjustment)	46-21
		10D	Copy / Image send / FAX image quality adjustment (Individual adjustment)	10D (1)	Color copy density adjustment (for each color copy mode) (separately for the low-density area and the high-density area) (No need to adjust normally)	46-1
				10D (2)	Monochrome copy density adjustment (for each monochrome copy mode) (separately for the low-density area and the high-density area) (No need to adjust normally)	46-2
				10D (3)	Color copy color balance, gamma adjustment (for each color copy mode) (No need to adjust normally)	46-10
				10D (4)	Monochrome copy density, gamma adjustment (for each monochrome copy mode) (No need to adjust normally)	46-16
10D (5)	Automatic monochrome (Copy/Scan/FAX) mode document density scanning operation (exposure operation) conditions setting (Normally no need to set)			46-19		

Job No.	Adjustment item list			Simulation	
ADJ 10/ SET1	Color balance and density adjustment	10D	Copy / Image send / FAX image quality adjustment (Individual adjustment)	10D (6) Document low density image density reproduction adjustment in the automatic monochrome (Copy/Scan/FAX) mode (No need to adjust normally) (Background density adjustment in the scanning section)	46-32
				10D (7) Copy/Scan low density image density adjustment (for each mode) (No need to adjust normally)	46-63
				10D (8) Color copy, text, line image reproduction adjustment (edge gamma, density adjustment) (Text, Map mode) (No need to adjust normally)	46-27
				10D (9) Monochrome (Copy/Scan/FAX) mode color document reproduction adjustment (No need to adjust normally)	46-37
				10D (10) Color copy mode dark area gradation (black component quantity) adjustment (No need to adjust normally)	46-38
				10D (11) Color (Copy/Scan) mode sharpness adjustment (No need to adjust normally)	46-60
				10D (12) Copy high density image density reproduction setting (Normally unnecessary to the setting change)	46-23
				10D (13) Copy color balance adjustment (Single color copy mode) (No need to adjust normally)	46-25
				10D (14) RSPF mode (Copy/Scan/FAX) density adjustment (No need to adjust normally)	46-9
				10D (15) Automatic color balance adjustment by the user (Copy color balance automatic adjustment ENABLE setting and adjustment)	26-53
				10D (16) Copy gamma, color balance adjustment for each dither (Automatic adjustment)	46-54
				10D (17) Dropout color adjustment (Normally not required.) (26cpm/36cpm/31cpm(A) machine)	46-55
				10D (18) Watermark adjustment (Normally not required) (26cpm/36cpm/31cpm(A) machine)	46-66
				10E	Printer image quality adjustment (Basic adjustment)
		10E (2) Printer color balance adjustment (Manual adjustment)	67-25		
		10F	Printer image quality adjustment (Individual adjustment)	10F (1) Printer density adjustment (Low density section density adjustment) (No need to adjust normally)	67-36
				10F (2) Printer high density image density reproduction setting (Supporting the high density section tone gap) (No need to adjust normally)	67-34
				10F (3) Printer gamma adjustment for each dither (Automatic adjustment) (No need to adjust normally) (Except for GDI printers)	67-54
10F (4) Automatic color balance adjustment by the user (Printer color balance automatic adjustment ENABLE setting and adjustment) (Normally unnecessary to the setting change)	26-53				
ADJ 11	Paper size sensor adjustment	11A Manual paper feed tray paper size (width) sensor adjustment	40-2		
		11B RSPF paper feed tray document size (width) sensor adjustment	53-6		
ADJ 12	Document size detection adjustment	12A Document size sensor detection point adjustment	41-1		
		12B Adjust the sensitivity of the original size sensor	41-2		
ADJ 13	Touch panel coordinate setting		65-1		
ADJ 14	Fusing paper guide position adjustment				
ADJ 15	Print image position, image magnification ratio, void area, off-center adjustment (Print engine) (Manual adjustment)	15A Print image magnification ratio adjustment (main scanning direction) (Print engine) (Manual adjustment)	50-10		
		15B Print image print area adjustment (Print engine) (Manual adjustment)	50-10/50/1		
		15C Print image off-center adjustment (Print engine) (Manual adjustment)	50-10		
ADJ 16	Scan image magnification ratio adjustment (Manual adjustment)	16A Scan image magnification ratio adjustment (main scanning direction) (Manual adjustment) (Document table mode)	48-1		
		16B Scan image magnification ratio adjustment (sub scanning direction) (Manual adjustment) (Document table mode)	48-1/48-5		
		16C Scan image magnification ratio adjustment (main scanning direction) (Manual adjustment) (RSPF mode)	48-1		
		16D Scan image magnification ratio adjustment (sub scanning direction) (Manual adjustment) (RSPF mode)	48-1		
ADJ 17	Scan image off-center adjustment (Manual adjustment)	17A Scan image off-center adjustment (Manual adjustment) (Document table mode)	50-12		
		17B Scan image off-center adjustment (Manual adjustment) (RSPF mode)	50-12/50-6		
ADJ 18	Copy image position, image loss adjustment (Manual adjustment)	18A Copy image position, image loss, void area adjustment (Manual adjustment) (Document table mode)	50-1		
		18B Image scanning position adjustment (Manual adjustment) (RSPF mode)	53-8		
		18C Copy image position, image loss, void area adjustment (Manual adjustment) (RSPF mode)	50-6		
ADJ 19	Finisher and punch unit adjustments (alignment, punch hole position, staple position)		3-10		

### 3. Details of adjustment

#### ADJ 1 Adjust the developing unit

##### 1-A Adjust the developing doctor gap

This adjustment must be performed in the following cases:

- \* The developing unit has been disassembled.
- \* When the print image density is low.
- \* When there is a blur on the print image.
- \* When there is unevenness in the print image density.
- \* The toner is excessively dispersed.

##### Important

Be careful not to attach a fingerprint, oil, grease, or a foreign material on the DV roller during the procedure. Also be careful not to scratch the DV roller surface.

If a fingerprint, oil, grease, or a foreign material is erroneously attached to the DV roller during the procedure, remove all developer from the developing unit and clean the roller with alcohol.

##### Important

Do not exert force when holding the DV Unit.

- 1) Remove the developing unit from the main unit, and remove the developing doctor cover.

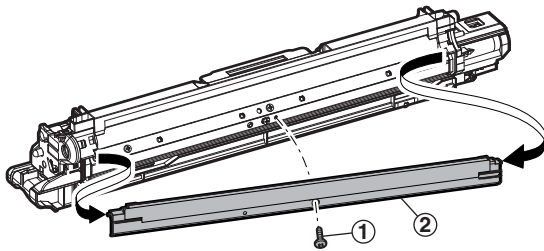

- 2) Loosen the developing doctor fixing screw.

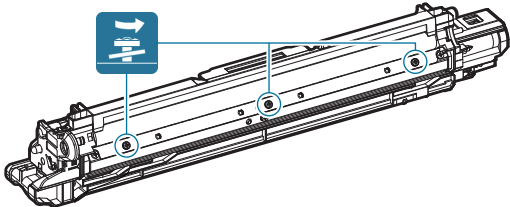

- 3) Insert a thickness gauge of 0.65mm in between 40mm - 70mm from the edge of the developing doctor.

##### Important

##### Note for use of a thickness gauge

- Do not insert the gauge diagonally.
- The gauge must pass freely.
- The advisable point of measurement is the MIN point of the DV roller oscillation.

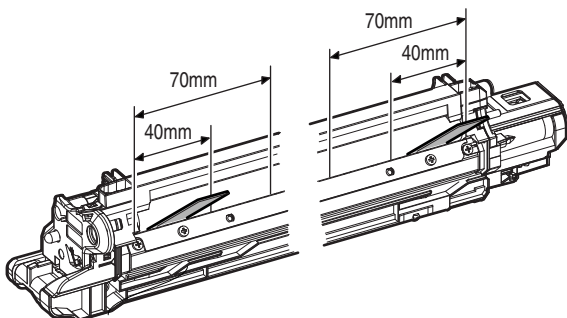

- 4) Push the developing doctor in the arrow direction, and tighten the fixing screw of the developing doctor. (Perform the similar procedure for the front frame and the rear frame.)

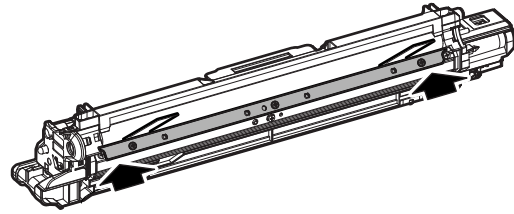

- 5) Check that the doctor gaps at two positions in 40mm - 70mm from the both sides of the developing doctor are in the range of  $0.65 \pm 0.05\text{mm}$ .

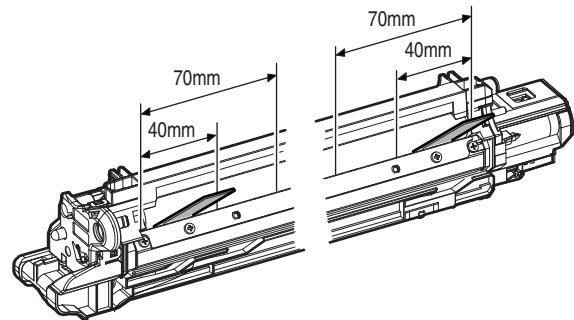

##### 1-B Adjust the developing roller main pole position

This adjustment must be performed in the following cases:

- \* The developing unit has been disassembled.
- \* When the print image density is low.
- \* When there is a blur on the print image.
- \* When there is unevenness in the print image density.
- \* The toner is excessively dispersed.

##### Important

Be careful not to leave a fingerprint, oil, grease, or a foreign material on the DV roller during the procedure. Also be careful not to scratch the DV roller surface.

If a fingerprint, oil, grease, or a foreign material is erroneously attached to the DV roller during the procedure, remove all developer from the developing unit and clean the roller with alcohol.

##### Important

Do not exert force when holding the DV Unit.

- 1) Remove the developing doctor cover, and place the developing unit on a flat surface.
- 2) Attach a piece of string to a sewing needle or pin.
- 3) Hold the thread and bring the needle near the developing roller. (Do not use a paper clip because too heavy. It will not provide a correct position.)

- 4) Mark the developing roller surface on the extension line of the needle with the needle at 2 - 3mm from the developing roller edge. (Never touch the needle tip to the developing roller.)

**Important**

Marking must be made at the edge section (non-image area) of the DV roller.

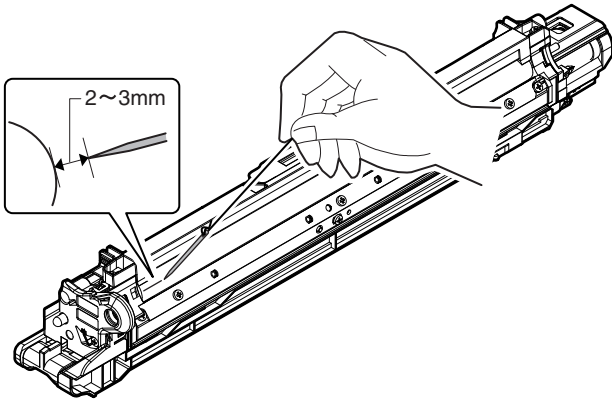

- 5) Measure the distance between the marking position and the DV doctor edge A position, and confirm that the distance is  $20.0 \pm 0.5$ mm.

If the distance is not within the above range, adjust the DV roller main pole position in the following procedures.

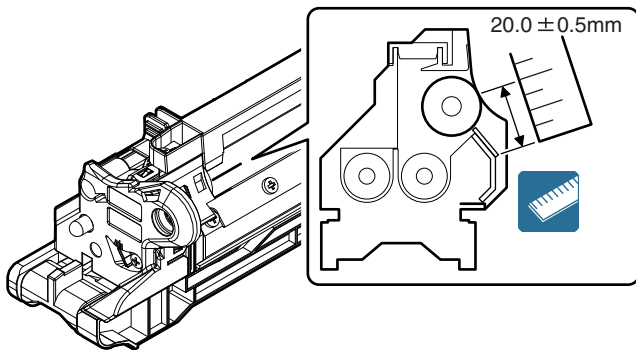

- 6) Remove the developing unit rear cover, loosen the fixing screw of the DV roller main pole adjustment plate, and move the adjustment plate in the arrow direction to adjust.

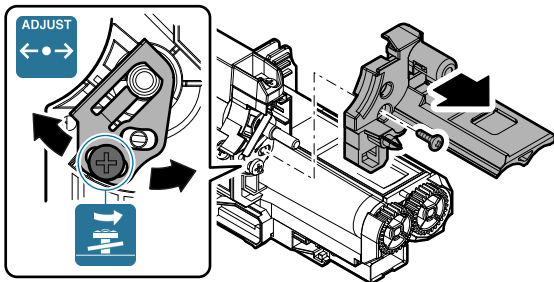

Repeat procedures 3) - 6) until the DV roller main pole position comes to the specified range.

- 7) After completion of the adjustment of the DV roller main pole position, fix the DV roller main pole adjustment plate with the fixing screw.

## 1-C Toner density control reference value setting

This adjustment must be performed in the following cases:

- \* When developer is replaced.

**Important**

Be sure to execute this adjustment only when developer is replaced. Never execute it in the other cases.

**Important**

Perform the toner density reference control level adjustment with the toner cartridges removed.

If adjustment is performed with toner cartridges installed, the EE-EL trouble code or an over-toned condition may occur.

- 1) With the front cabinet open, enter SIM25-2.

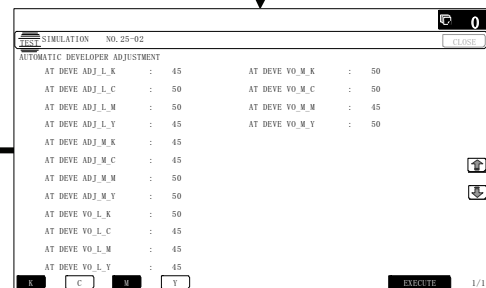
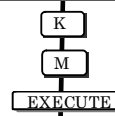
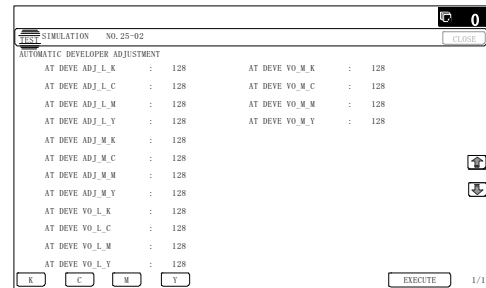

Abnormal end

Adjustment completed

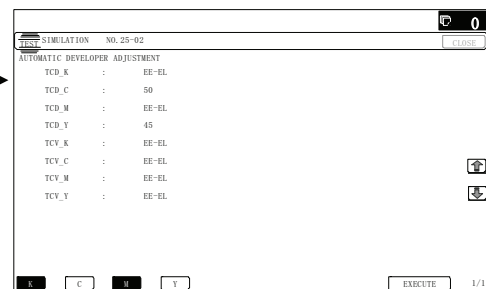
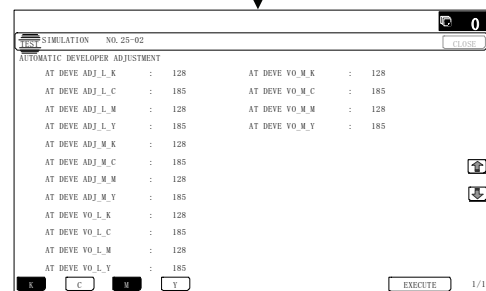



- 2) Close the front cabinet.
- 3) Select a developing unit to be adjusted.
- 4) When [EXECUTE] key is pressed, it is highlighted. The DV roller rotates, and the toner density sensor detects toner density, and the output value is displayed.

The above operation is executed for 1.5 minutes, and the average value of the toner density sensor detection level is set (saved) as the reference toner density control value.

When the reference toner density control adjustment operation is completed, [EXECUTE] key returns to normal from highlight. This makes known about whether the adjustment operation is completed or not.

The above operation is executed each of the lower speed mode and the middle speed mode, and the reference toner density control value is set for each of them.

**Important**

If the operation is interrupted within 1.5 minutes, the adjustment result is not reflected.

When [EXECUTE] key is pressed during the operation, the operation is stopped and [EXECUTE] key returns to the normal display.

If [EE-EU], [EE-EL], or [EE-EC] is displayed, setting of the reference toner density control value is not completed normally.

Troubleshoot the cause, remove the cause, and perform setting again.

Error display	Error name	Detail of error
EE-EL	EL abnormality	Sensor output level less than 1.0V, or control voltage over 8.0V.
EE-EU	EU abnormality	Sensor output level over 2.3V, or control voltage less than 2.0V.
EE-EC	EC abnormality	Sensor output level: other than $1.65 \pm 0.13V$

- 5) Cancel SIM 25-2.
- 6) Confirm that "Install the toner cartridge" is displayed, and install the toner cartridge by the following procedures.
- 7) Shake the toner cartridge horizontally several times.

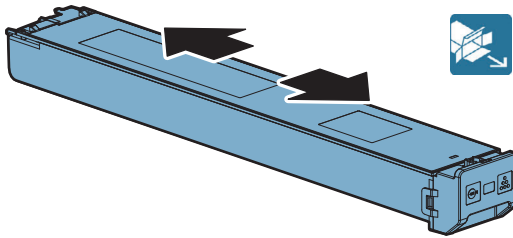

- 8) Open the front cabinet, and insert each toner cartridge.

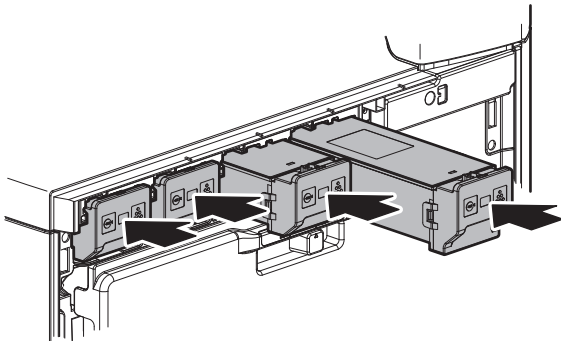

**Important**

Be sure to install the color cartridges to their proper positions. Avoid installation to a different color position.

**Important**

Do not forcibly insert the toner cartridge. Push it in until the cartridge is securely locked in place.

**Important**

Developing units removed, be sure to remove the toner cartridges as well to prevent toner clogging.

**Color toner cartridge positions**

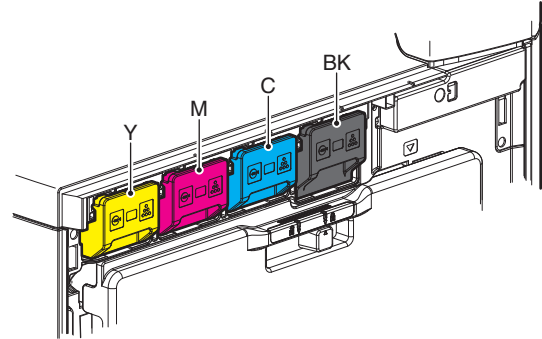

- 9) Close the front cabinet.
- 10) Confirm that "Toner replenishment in progress" is displayed, and wait until the display disappears. (It takes 30 sec - 6 min.)

**Note**

This procedure is for checking the toner supply operation from the toner cartridge to the DV unit. The operation time differs depending on the toner quantity in the toner cartridge, uneven distribution of toner, and the internal state of the toner cartridge.

**Important**

Do not perform operations which interrupt the above operation, such as opening the front cover, entering the SIM mode, and turning OFF/ON the power. If this precaution is ignored, Trouble codes F2-40 - 43 or F2-64 - 67 or a over-toned condition may occur.

**Important**

When replacing developer, always replace all the three colors of Yellow, Magenta, and Cyan.

If only one color is replaced, color balance may be adversely affected. Black developer can be replaced individually.

**Important**

When developer is replaced, be sure to perform the color balance adjustment.

**Important**

When not replacing the developer, do not execute SIM25-2.

## ADJ 2 Adjusting high voltage values

### 2-A Adjust the main charger grid voltage

This adjustment must be performed in the following cases:

- \* When the MC/DV high voltage power PWB is replaced.
- \* U2 trouble has occurred.
- \* The PCU PWB has been replaced.
- \* The EEPROM of the PCU PWB has been replaced.

1) Enter the SIM 8-2 mode.

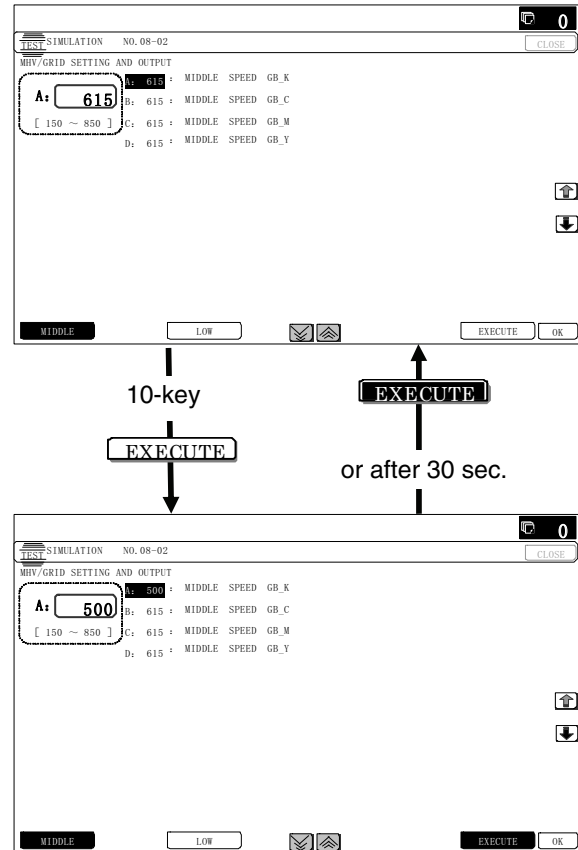

2) Select an output mode and an item to be adjusted.

Item/Display (Mode)	Content	Adjustment range	Actual voltage				
			18cpm/ 20cpm/ 23cpm machine	26cpm/ 31cpm machine	36cpm machine		
MIDDLE	A MIDDLE SPEED GB_K	Main charger grid voltage (Middle speed mode)	K	150 - 850	-615V±5V	-620V±5V	-625V±5V
	B MIDDLE SPEED GB_C	Main charger grid voltage (Middle speed mode)	C	150 - 850	-615V±5V	-620V±5V	-625V±5V
	C MIDDLE SPEED GB_M	Main charger grid voltage (Middle speed mode)	M	150 - 850	-615V±5V	-620V±5V	-625V±5V
	D MIDDLE SPEED GB_Y	Main charger grid voltage (Middle speed mode)	Y	150 - 850	-615V±5V	-620V±5V	-625V±5V
LOW	A LOW SPEED GB_K	Main charger grid voltage (Low speed mode)	K	150 - 850	-610V±5V	-610V±5V	-610V±5V
	B LOW SPEED GB_C	Main charger grid voltage (Low speed mode)	C	150 - 850	-590V±5V	-590V±5V	-590V±5V
	C LOW SPEED GB_M	Main charger grid voltage (Low speed mode)	M	150 - 850	-590V±5V	-590V±5V	-590V±5V
	D LOW SPEED GB_Y	Main charger grid voltage (Low speed mode)	Y	150 - 850	-590V±5V	-590V±5V	-590V±5V

3) Enter the adjustment value (specified value) in the middle speed mode, and press [OK] key.

Enter the adjustment value of each mode which is specified on the label attached on the MC/DV high voltage power PWB.

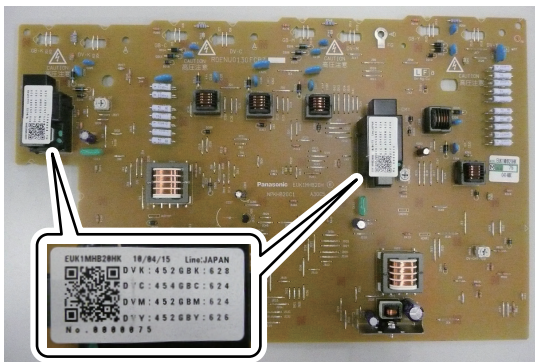

When [EXECUTE] key is pressed, the voltage entered in the procedure 3) is outputted for 30sec and the set value is saved. When [EXECUTE] key is pressed again, the output is stopped.

#### Important

Note that the adjustment value may differ depending on the MC/DV high voltage power PWB.

Since the adjustment value label is attached on the MC/DV high voltage PWB, the PWB must be removed in order to check the adjustment value.

This is a troublesome procedure. Therefore, it is advisable to put down the adjustment value in advance.

When the adjustment value (specified value) of the middle speed mode is set, the adjustment values of the other modes are automatically set according to the middle speed mode setting in a certain relationship.

#### Important

Since the high voltage output cannot be checked with a digital multi meter in this model, a judgment of the output must be made by checking the print image quality.

## 2-B Adjust the developing bias voltage

This adjustment must be performed in the following cases:

- \* When the MC/DV high voltage power PWB is replaced.
- \* U2 trouble has occurred.
- \* The PCU PWB has been replaced.
- \* The EEPROM of the PCU PWB has been replaced.

1) Enter the SIM 8-1 mode.

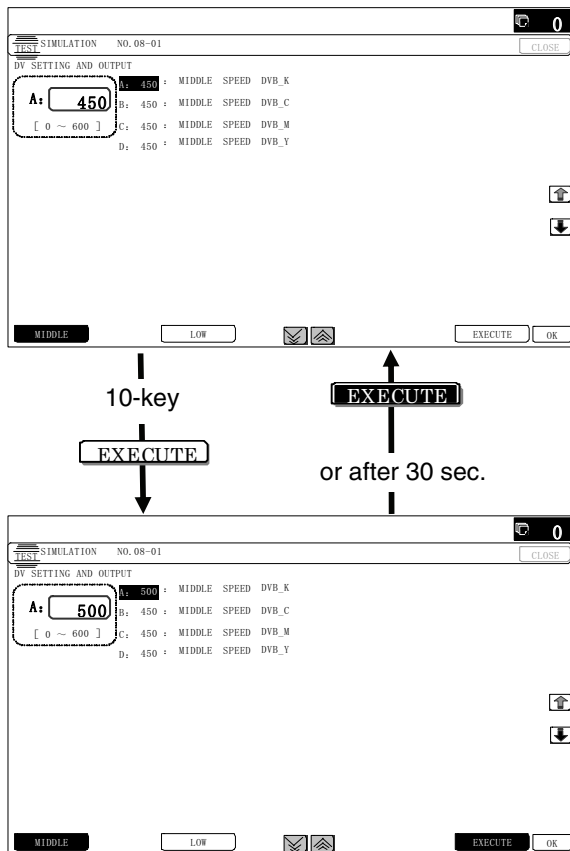

2) Select an output mode and an item to be adjusted.

Item/Display (Mode)	Content	Adjustment range	Actual voltage
MIDDLE	A MIDDLE SPEED DVB_K Developing bias voltage (Middle speed mode)	K 0 - 600	-450V ±5V
	B MIDDLE SPEED DVB_C Developing bias voltage (Middle speed mode)	C 0 - 600	-450V ±5V
	C MIDDLE SPEED DVB_M Developing bias voltage (Middle speed mode)	M 0 - 600	-450V ±5V
	D MIDDLE SPEED DVB_Y Developing bias voltage (Middle speed mode)	Y 0 - 600	-450V ±5V

Item/Display (Mode)	Content	Adjustment range	Actual voltage
LOW	A LOW SPEED DVB_K Developing bias voltage (Low speed mode)	K 0 - 600	-450V ±5V
	B LOW SPEED DVB_C Developing bias voltage (Low speed mode)	C 0 - 600	-430V ±5V
	C LOW SPEED DVB_M Developing bias voltage (Low speed mode)	M 0 - 600	-430V ±5V
	D LOW SPEED DVB_Y Developing bias voltage (Low speed mode)	Y 0 - 600	-430V ±5V

3) Enter the adjustment value (specified value) in the middle speed mode, and press [OK] key.

Enter the adjustment value of each mode which is specified on the label attached on the MC/DV high voltage power PWB.

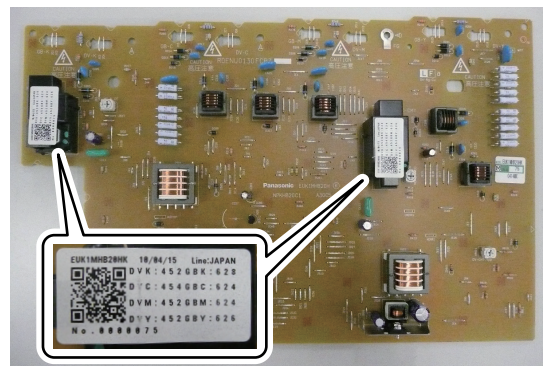

When [EXECUTE] key is pressed, the voltage entered in the procedure 3) is outputted for 30sec and the set value is saved. When [EXECUTE] key is pressed again, the output is stopped.

### Important

Note that the adjustment value may differ depending on the MC/DV high voltage power PWB.

Since the adjustment value label is attached on the MC/DV high voltage PWB, the PWB must be removed in order to check the adjustment value.

This is a troublesome procedure. Therefore, it is advisable to put down the adjustment value in advance.

When the adjustment value (specified value) of the middle speed mode is set, the adjustment values of the other modes are automatically set according to the middle speed mode setting in a certain relationship.

### Important

Since the high voltage output cannot be checked with a digital multi meter in this model, a judgment of the output must be made by checking the print image quality.

## 2-C Transfer current and voltage adjustment

This adjustment must be performed in the following cases:

- \* When the TC high voltage PWB is replaced.
- \* U2 trouble has occurred.
- \* The PCU PWB has been replaced.
- \* The EEPROM of the PCU PWB has been replaced.

1) Enter the SIM 8-6 mode.

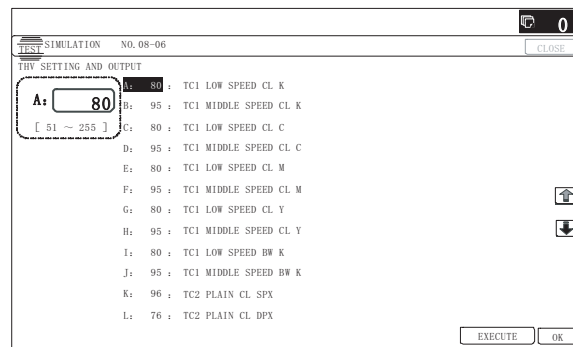

10-key  
EXECUTE

EXECUTE  
or after 30 sec.

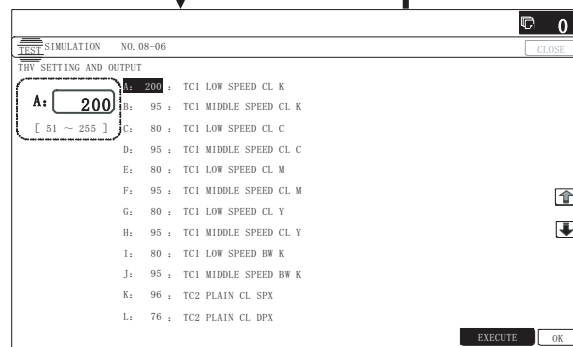

2) Select an item to be adjusted.

Item/Display	Content	Setting range	18cpm/20cpm/ 23cpm machine		26cpm/31cpm machine		36cpm machine					
			Default value	Actual output value	Default value	Actual output value	Default value	Actual output value				
A	TC1 LOW SPEED CL K	Primary transfer bias adjustment value	Color	K	Low speed	51 - 255	80	6 $\mu$ A	80	6 $\mu$ A	80	6 $\mu$ A
B	TC1 MIDDLE SPEED CL K				Middle speed	51 - 255	95	8 $\mu$ A	109	10 $\mu$ A	117	11 $\mu$ A
C	TC1 LOW SPEED CL C			C	Low speed	51 - 255	80	6 $\mu$ A	80	6 $\mu$ A	80	6 $\mu$ A
D	TC1 MIDDLE SPEED CL C				Middle speed	51 - 255	95	8 $\mu$ A	109	10 $\mu$ A	117	11 $\mu$ A
E	TC1 LOW SPEED CL M			M	Low speed	51 - 255	80	6 $\mu$ A	80	6 $\mu$ A	80	6 $\mu$ A
F	TC1 MIDDLE SPEED CL M				Middle speed	51 - 255	95	8 $\mu$ A	109	10 $\mu$ A	117	11 $\mu$ A
G	TC1 LOW SPEED CL Y			Y	Low speed	51 - 255	80	6 $\mu$ A	80	6 $\mu$ A	80	6 $\mu$ A
H	TC1 MIDDLE SPEED CL Y				Middle speed	51 - 255	95	8 $\mu$ A	109	10 $\mu$ A	117	11 $\mu$ A
I	TC1 LOW SPEED BW K	Black/White	K	Low speed	51 - 255	80	6 $\mu$ A	80	6 $\mu$ A	80	6 $\mu$ A	
J	TC1 MIDDLE SPEED BW K			Middle speed	51 - 255	95	8 $\mu$ A	109	10 $\mu$ A	117	11 $\mu$ A	

Item/Display		Content				Setting range	18cpm/20cpm/23cpm machine		26cpm/31cpm machine		36cpm machine	
							Default value	Actual output value	Default value	Actual output value	Default value	Actual output value
K	TC2 PLAIN CL SPX	Secondary transfer bias adjustment value	Color	Standard paper	Front surface	51 - 255	96	-35μA	103	-40μA	110	-45μA
L	TC2 PLAIN CL DPX				Back surface	51 - 255	76	-20μA	90	-30μA	96	-35μA
M	TC2 PLAIN BW SPX		Black/White		Front surface	51 - 255	96	-35μA	103	-40μA	110	-45μA
N	TC2 PLAIN BW DPX				Back surface	51 - 255	76	-20μA	90	-30μA	96	-35μA
O	TC2 HEAVY1 CL SPX		Color	Heavy paper 1	Front surface	51 - 255	83	-25μA	83	-25μA	83	-25μA
P	TC2 HEAVY1 CL DPX				Back surface	51 - 255	76	-20μA	76	-20μA	76	-20μA
Q	TC2 HEAVY1 BW SPX		Black/White		Front surface	51 - 255	69	-15μA	69	-15μA	69	-15μA
R	TC2 HEAVY1 BW DPX				Back surface	51 - 255	69	-15μA	69	-15μA	69	-15μA
S	TC2 HEAVY2 CL		Color	Heavy paper 2		51 - 255	83	-25μA	83	-25μA	83	-25μA
T	TC2 HEAVY2 BW				Black/White		51 - 255	69	-15μA	69	-15μA	69
U	TC2 OHP CL		Color	OHP		51 - 255	69	-15μA	69	-15μA	69	-15μA
V	TC2 OHP BW				Black/White		51 - 255	69	-15μA	69	-15μA	69
W	TC2 ENVELOPE CL		Color	Envelope		51 - 255	69	-15μA	69	-15μA	69	-15μA
X	TC2 ENVELOPE BW				Black/White		51 - 255	69	-15μA	69	-15μA	69
Y	TC2 THIN CL		Color	Thin paper		51 - 255	96	-35μA	103	-40μA	110	-45μA
Z	TC2 THIN BW				Black/White		51 - 255	96	-35μA	103	-40μA	110
AA	TC2 GLOSSY CL		Color	Gloss paper		51 - 255	83	-25μA	83	-25μA	83	-25μA
AB	TC2 GLOSSY BW				Black/White		51 - 255	69	-15μA	69	-15μA	69
AC	TC2 CLEANING		Secondary transfer cleaning bias adjustment value	Cleaning process (negative pole)		51 - 255	59	-8μA	59	-8μA	59	-8μA
AD	TC2 CLEAN LOW SPD			Low speed print mode		0 - 255	26	0V	26	0V	26	0V
AE	TC2 CLEAN MIDDLE SPD	Middle speed print mode		0 - 255	26	0V	26	0V	26	0V		
AF	TC2 CLEAN CLEANING	Cleaning bias (positive pole)		0 - 255	102	500V	102	500V	102	500V		
AG	PTC LOW SPEED CL	PTC current adjustment value	Color	Low speed	51 - 255	73	-200μA	73	-200μA	73	-200μA	
AH	PTC MIDDLE SPEED CL			Middle speed	51 - 255	73	-200μA	73	-200μA	73	-200μA	
AI	PTC LOW SPEED BW		Black/White	Low speed	51 - 255	73	-200μA	73	-200μA	73	-200μA	
AJ	PTC MIDDLE SPEED BW			Middle speed	51 - 255	73	-200μA	73	-200μA	73	-200μA	
AK	CASE VOLT LOW CL	PTC voltage adjustment value	Color	Low speed	0 - 255	0	0V	0	0V	0	0V	
AL	CASE VOLT MID CL			Middle speed	0 - 255	0	0V	0	0V	0	0V	
AM	CASE VOLT LOW BW		Black/White	Low speed	0 - 255	0	0V	0	0V	0	0V	
AN	CASE VOLT MID BW			Middle speed	0 - 255	0	0V	0	0V	0	0V	

3) Enter the adjustment value (specified value), and press [OK] key.

When [EXECUTE] key is pressed, the voltage entered in the procedure 3) is outputted for 30sec and the set value is saved.

When [EXECUTE] key is pressed again, the output is stopped.

By setting the default value (specified value), the specified output is provided.

## ADJ 3 Image density sensor adjustment

Before executing this adjustment, check to confirm the following items.

- \* Check to confirm that the color image density sensor (image registration sensor F) and the black image density sensor (image registration sensor R) are clean.
- \* Check to confirm that the image density sensor calibration plate is clean.
- \* Check to confirm that the transfer belt is clean and free from scratches.

### 3-A Image density sensor calibration

There are some parts variations in the image density sensor section. Therefore, the absolute image density detection level differs in each machine. To correct this, calibration is executed.

This adjustment must be performed in the following cases:

- \* When the color image density sensor (image registration sensor F) is replaced.
- \* When the image registration sensor unit is replaced.
- \* U2 trouble has occurred.
- \* The PCU PWB has been replaced.
- \* The EEPROM of the PCU PWB has been replaced.
- \* The image density sensor and the standard reflection plate are cleaned.

Perform the color image density sensor (image registration sensor F) calibration in one of the following methods.

#### Method 1

Color image density sensor (Image registration sensor F) calibration (SIM44-61)

When the image density sensor unit is replaced, perform the adjustment by this procedure.

When the registration sensor unit is replaced, the calibration value is set manually with this method. The calibration jig is not required.

#### Method 2

Color image density sensor (Image registration sensor F) calibration (SIM44-13)

When the color image density sensor (image registration sensor F) is solely replaced, be sure to perform the adjustment by this procedure.

A calibration jig is required for this procedure.

The adjustment by this method must be performed in the following cases:

- The SIM44-2 PCS\_CL LED ADJ value is increased by aging and dirt of the image density sensor and the standard reflection plate.
- When the density of an output image is decreased and the difference between the SIM44-2 PCS\_CL LED ADJ value and the SIM44-13 PCS\_CL LED ADJ value is 30 or more, the image density sensor, the registration sensor, and the standard reflection plate may be dirtied.

In this case, clean the image density sensor, the registration sensor, and the standard reflection plate with dry cloth, and perform calibration with SIM44-13 by using the calibration tool (UKOG-0318FCZZ).

#### a. Procedure by calibration (SIM44-61) of the color image density sensor (image registration sensor F)

- 1) Enter the SIM44-61 mode.

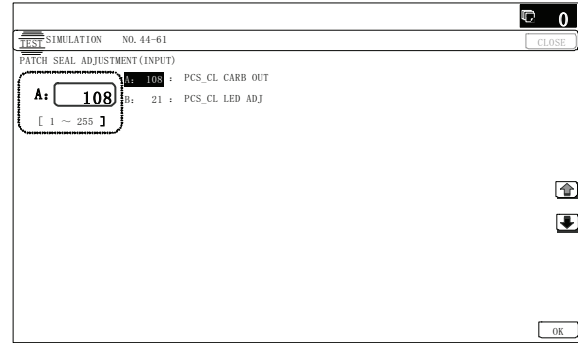

- 2) Select an adjustment item.

Item/Display	Content	Setting range	Default value	
A	PCS_CL CARB OUT	Calibration plate sensor value	1 - 255	108
B	PCS_CL LED ADJ	Color sensor light emitting quantity adjustment value	1 - 255	21

- 3) Enter the adjustment value with 10 key.

As the adjustment value, enter the value on the label attached to the slot section of the toner cartridge (BK) of the sensor unit.

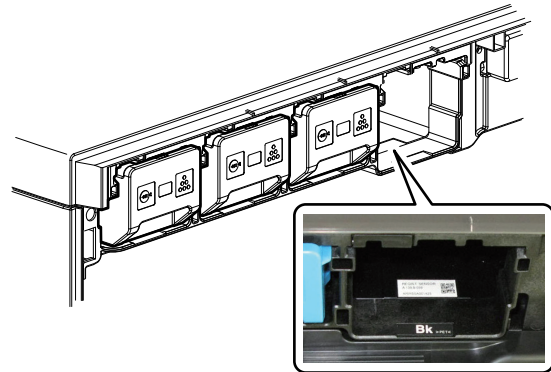

- 4) Press [OK] key.

**b. Color image density sensor (Image registration sensor F) calibration (Method by SIM44-13)**

- 1) Enter the SIM44-13 mode.

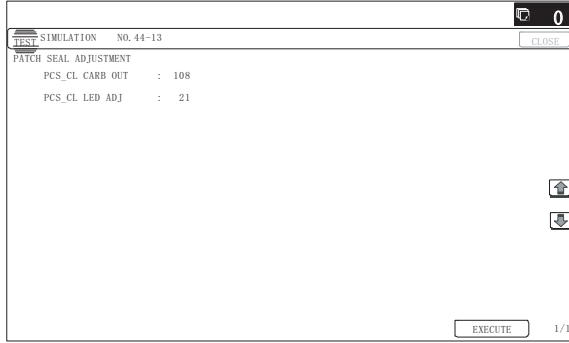

- 2) Open the front cover, and remove the waste toner box. Check to confirm that the belt tension of the primary transfer unit is released (the separation lever of the primary transfer unit is as shown in the figure).  
If the belt tension is not released, turn the separation lever to the state shown in the figure.

**Important**

When the transfer belt tension of the primary transfer unit is released manually, turn on the power again after completion of the work.

This procedure initializes the transfer roller to return it to the home position.

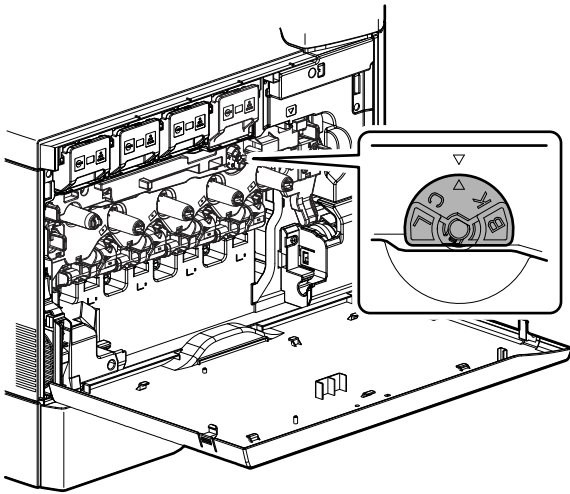

- 3) Open the right paper transport unit, and remove the BK developing unit, the BK OPC drum unit, and the primary transfer unit.

- 4) Install the color image density sensor (image registration sensor F) calibration jig (UKOG-0318FCZZ) to the sensor housing section.

Engage the calibration jig with the projection of the sensor housing, and slide it to the rear frame side.

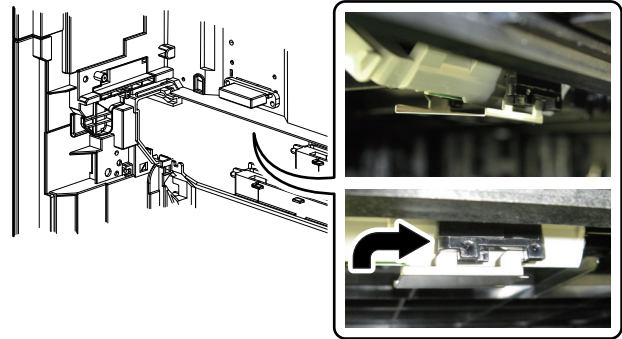

- 5) Close the right paper transport unit, and manually turn ON the front door switch.
- 6) Press [EXECUTE] key.  
Color image density sensor (image registration sensor F) calibration is automatically executed. When the operation is completed, the adjustment result is displayed and [EXECUTE] key returns to the normal display.

Display/Item	Content	Adjustment value range	Default
A PCS_CL CARB OUT	Color image density sensor LED current adjustment target value	1 - 255	108
B PCS_CL LED ADJ	Color image density sensor LED current adjustment target value (PCS CL CARB OUT) registered LED current level	1 - 255	21

If the adjustment is not completed normally, "ERROR" is displayed.

When an error occurs, the adjustment result is not revised.

In that case, check the following sections for any abnormality. If any abnormality is found, repair and execute calibration again.

- \* Color image density sensor (image registration sensor F)
- \* PCU PWB
- \* Image sensor calibration jig (dirt, scratch, discoloration)
- \* Image density sensor standard reflection plate (dirt, scratch, discoloration)

The message is displayed, indicating that the jig is removed and the primary transfer unit is installed.

- 7) Remove the jig and install the BK developing unit, the BK OPC drum unit, and the primary transfer unit, and close the right paper transport unit.
- 8) [EXECUTE] key is pressed again.

**Important**

The image sensor calibration jig must be stored at lower temperatures and low humidity without external lights.

**Important**

When this adjustment is executed, perform the ADJ10B copy/printer color balance adjustment with SIM46-74.

### 3-B Image density sensor adjustment

The image density sensor standard reflection plate and the transfer belt surface are used to make the sensitivity adjustment of the color image density sensor (image registration sensor F) and the black image density sensor (image registration sensor R).

This adjustment executes automatically at the outset of registration adjustment operation and process control operation as well as SIM44-2.

Normally, therefore, it is not required to perform this adjustment. It is performed only when the sensor is replaced or when the adjustment result is checked.

- 1) Enter SIM44-2 mode.

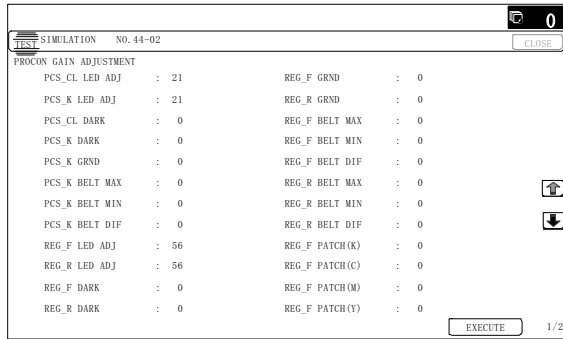

- 2) Press [EXECUTE] key.

The sensitivity adjustments of the color image density sensor (image registration sensor F) and the black image density sensor (image registration sensor R) are automatically performed.

After completion of the adjustment, the adjustment result is displayed and [EXECUTE] key returns to the normal display.

If the adjustment is not completed normally, "ERROR" is displayed.

Mode	Error display	Error content	
Adjustment value for process control operation mode	BK_SEN_ADJ_ERR	Black image density sensor adjustment abnormality	PCS_K_LED_ADJ error (The target value is not obtained after retried three times.)
	CL_SEN_ADJ_ERR	Color image density sensor adjustment abnormality	PCS_CL_LED_ADJ error (The target value is not obtained after retried three times.)
	BELT_READ_ERR	Transfer belt surface reading abnormality	PCS_K_GRND error (The surface detection level is maximum or the minimum value difference is outside a reference range.)
Adjustment value for image registration operation mode	REG_SEN_F_ADJ_ERR	Registration sensor F adjustment abnormality	REG_F_LED_ADJ error (The target value is not obtained after retried three times.)
	REG_SEN_R_ADJ_ERR	Registration sensor R adjustment abnormality	REG_R_LED_ADJ error (The target value is not obtained after retried three times.)
	REG_BELT_F_READ_ERR	F side transfer belt surface reading abnormality	REG_F_GRND error (The surface detection level is maximum or the minimum value difference is outside a reference range.)
	REG_BELT_R_READ_ERR	R side transfer belt surface reading abnormality	REG_R_GRND error (The surface detection level is maximum or the minimum value difference is outside a reference range.)

When an error occurs, check the following sections for any abnormality.

- Color image density sensor (image registration sensor F)
- Black image density sensor (image registration sensor R)
- PCU PWB
- Transfer belt (dirt, scratch)
- Transfer belt cleaner
- Image density sensor standard reflection plate (dirt, scratch, discoloration)

If any abnormality is found, repair and adjust again.

If an error occurs, the adjustment result is not revised.

### ADJ 4 Image lead edge position, image loss, void area, image off-center, image magnification ratio adjustment (Automatic adjustment)

The following adjustment items can be executed automatically with SIM50-28.

- \* ADJ 15  
Print image position, image magnification ratio, void area, off-center adjustment (Print engine) (Manual adjustment)
- \* ADJ 16  
Scan image magnification ratio adjustment (Manual adjustment)
- \* ADJ 17  
Scan image off-center adjustment (Manual adjustment)
- \* ADJ 18  
Copy image position, image loss adjustment (Manual adjustment)  
(Menu in SIM50-28 mode)

Display/Item	Content
OC ADJ	Image loss off-center sub scanning direction image magnification ratio adjustment (Document table mode)
BK-MAG ADJ	Main scanning direction image magnification ratio adjustment
SPF ADJ	Image loss off-center sub scanning direction image magnification ratio adjustment (RSPF mode)
SETUP/PRINT ADJ	Print lead edge adjustment, image off-center (each paper feed tray, duplex mode) adjustment
RESULT	Adjustment result display
DATA	Display of data used when an adjustment is executed

### 4-A Print image main scanning direction automatic magnification ratio adjustment (Print engine)

- 1) Enter the SIM50-28 mode.

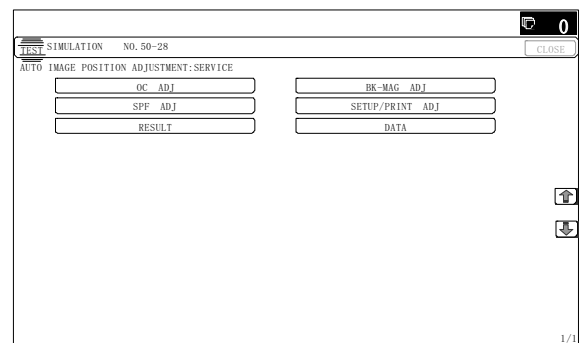

- 2) Select [BK-MAG ADJ] with the key.



- 3) Select the paper feed tray with paper in it with the key.  
(Any paper size will do.)

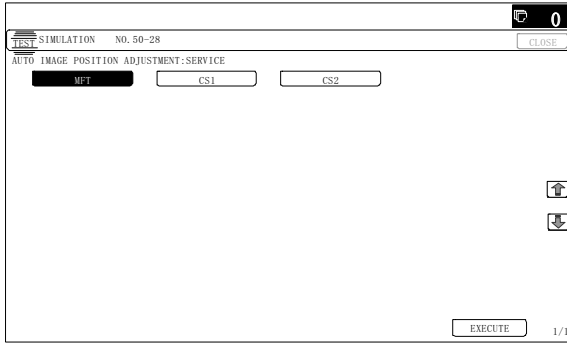

- 4) Press [EXECUTE] key.  
The adjustment pattern is printed out.
- 5) Set the adjustment pattern on the document table.

**Important**

Fit the adjustment pattern correctly with the document guide.  
In this case, put 5 sheets of white paper on the printed adjustment pattern.

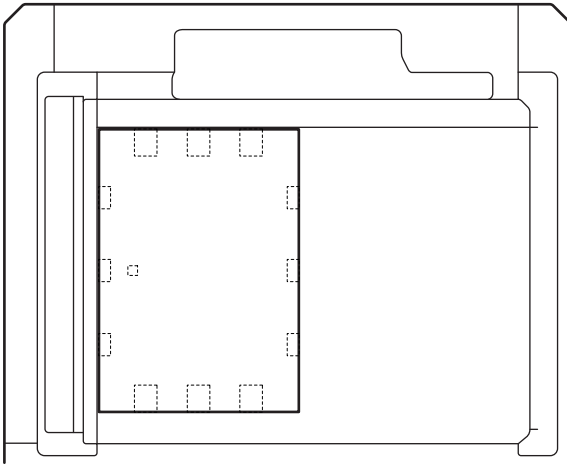

- 6) Press [EXECUTE] key.

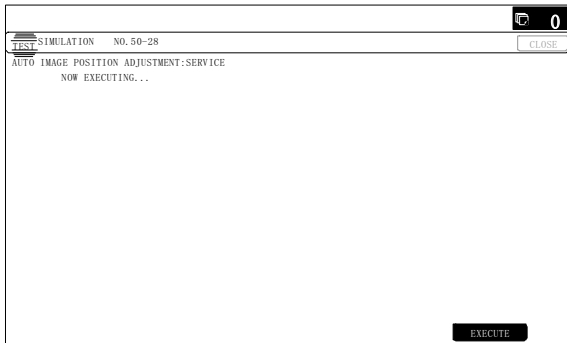

The following item is automatically adjustment.  
\* Print image main scanning direction image magnification ratio.

- 7) Press [OK] key.  
The adjustment result becomes valid.

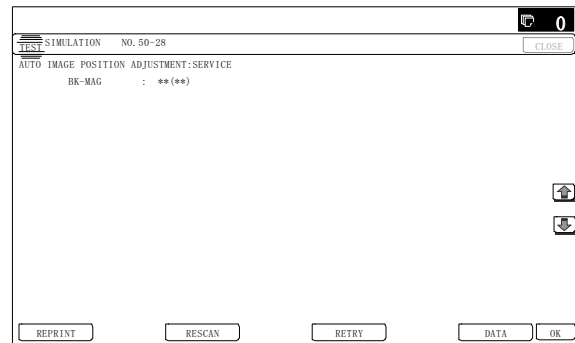

#### 4-B Print image off-center automatic adjustment (Print engine) (Each paper feed tray)

- 1) Enter the SIM50-28 mode.

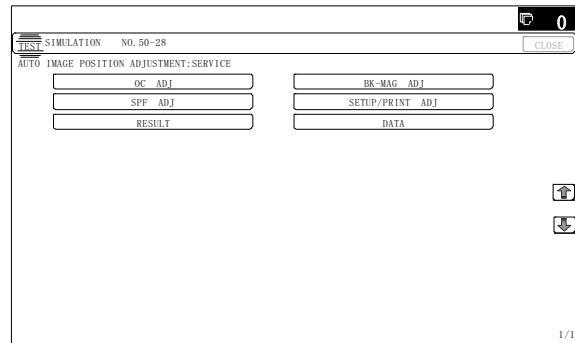

- 2) Select [SETUP/PRINT ADJ] with the key.
- 3) Select [ALL] with the key.

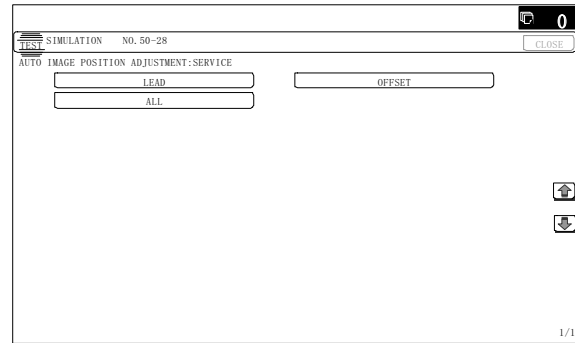

**Note**

By pressing [LEAD] or [OFFSET] key, the following items can be executed individually.

\* [LEAD]: Print image lead edge image position adjustment

\* [OFFSET]: Print image off-center adjustment

When [ALL] is selected, both of the above two items are executed simultaneously.

- 4) Select a paper feed tray to be adjusted.

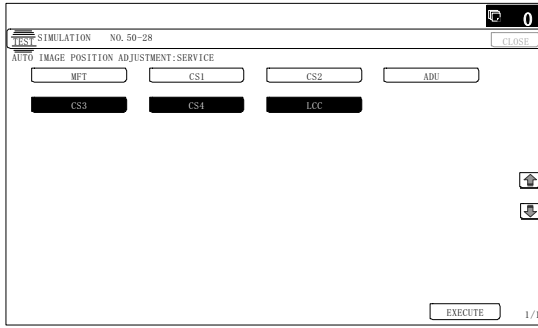

- 5) Press [EXECUTE] key.  
The adjustment pattern is printed out.
- 6) Set the adjustment pattern on the document table.

**Important**

Fit the adjustment pattern correctly with the document guide.  
In this case, put 5 sheets of white paper on the printed adjustment pattern.

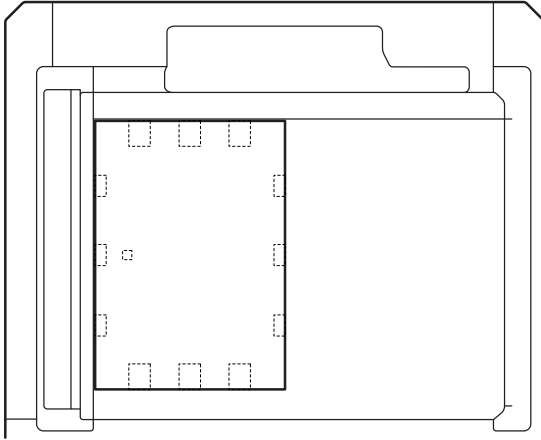

- 7) Press [EXECUTE] key.  
The following item is automatically adjustment.  
\* Print image lead edge image position adjustment  
\* Print image off-center adjustment
  - 8) Press [OK] key.  
The adjustment result becomes valid.
- Perform procedures 4) to 7) for each paper feed tray.

#### **4-C Copy mode image lead edge position, image loss, void area, image off-center, sub scanning direction image magnification ratio automatic adjustment (Scanner) (Document table mode)**

- 1) Enter the SIM50-28 mode.

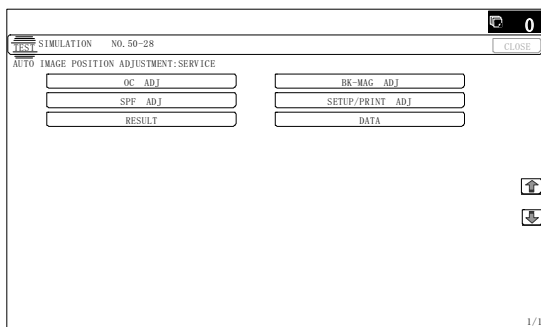

- 2) Select [OC ADJ] with the key.
- 3) Select the paper feed tray with paper in it with the key.  
(Any paper size will do.)

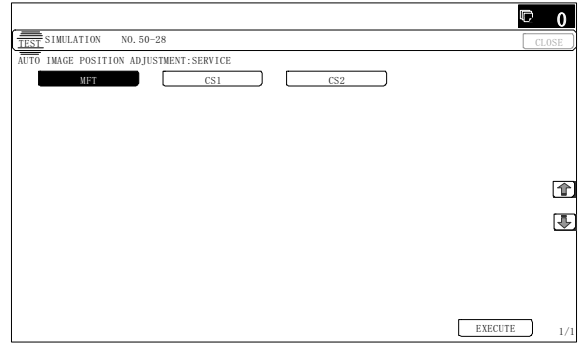

- 4) Press [EXECUTE] key.  
The adjustment pattern is printed out.
- 5) Set the adjustment pattern on the document table.

**Important**

Fit the adjustment pattern correctly with the document guide.  
In this case, put 5 sheets of white paper on the printed adjustment pattern.

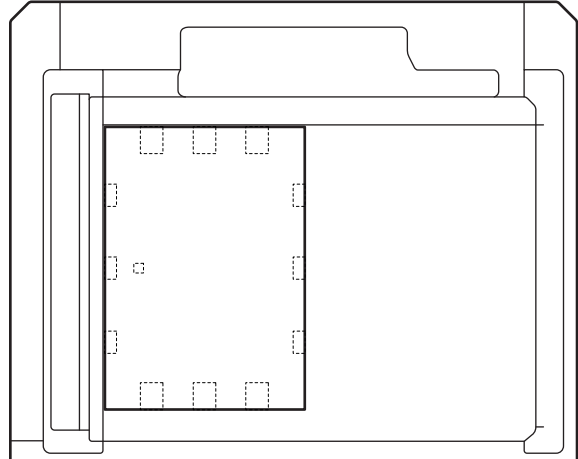

- 6) Press [EXECUTE] key.

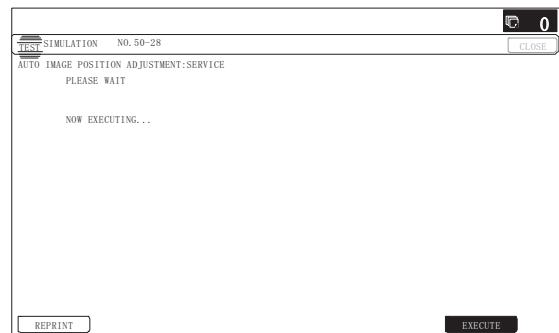

The following item is automatically adjustment.

- \* Copy lead edge image reference position adjustment, image off-center, sub scanning direction image magnification ratio automatic adjustment

- 7) Press [OK] key.  
The adjustment result becomes valid.



#### 4-D Copy mode image lead edge position, image loss, void area, image off-center, sub scanning direction image magnification ratio automatic adjustment (Scanner) (RSPF mode)

- 1) Enter the SIM50-28 mode.

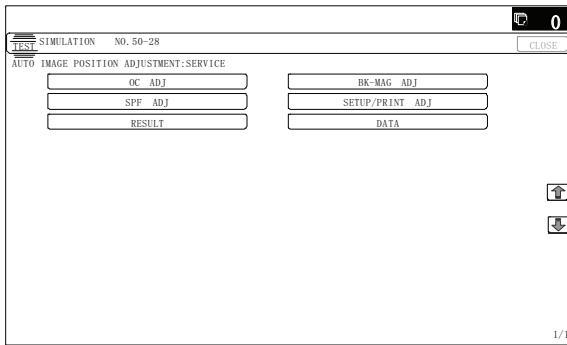

- 2) Press the [SPF ADJ] key.

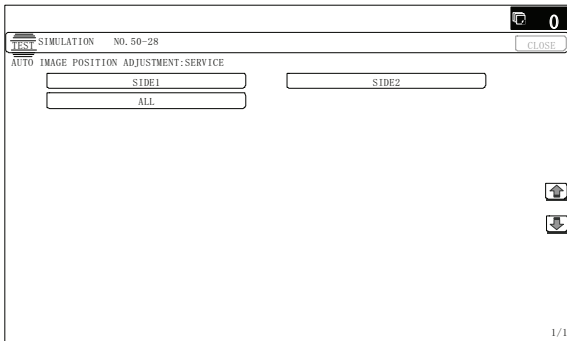

- 3) Proceed to one of the three screens for selecting the cassette used to print RSPF adjustment patterns by selecting the corresponding button:
  - SIDE1: RSPF adjustment for the front side
  - SIDE2: RSPF adjustment for the back side
  - ALL: RSPF adjustment for both the front and back sides
- 4) Select one of the cassettes that can be used to print RSPF adjustment patterns. (Multiple selection is not allowed.)
- 5) Press the [EXECUTE] key, and the machine starts self-print of RSPF adjustment patterns.
  - \* The screen shows a message indicating that the machine is self-printing RSPF adjustment patterns.
  - When self-print finishes, the next screen appears where you can start RSPF adjustments.

- 6) RSPF adjustment patterns are loaded into the RSPF. (Set so that the pattern surface faces up.)

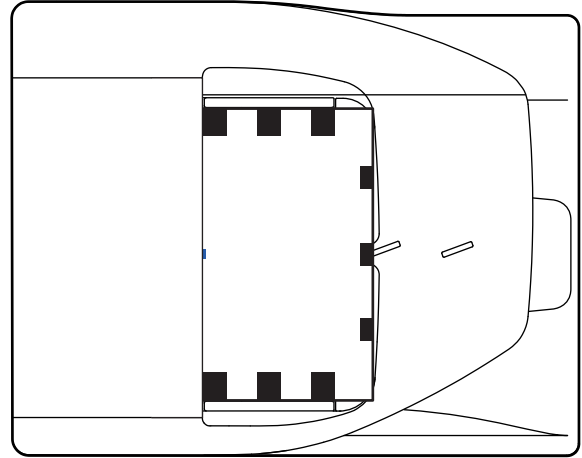

\* By pressing the [REPRINT] key, you can return to the cassette selection screen and have the machine self-print RSPF adjustment patterns again.

- 7) Press the [EXECUTE] key, and the machine starts reading RSPF adjustment patterns (for the front side).

\* The screen shows a message indicating that the machine is reading and calculating RSPF adjustment patterns (for the front side).

The machine starts calculating the adjustment amount (for the front side) after it has read the patterns for the front side.

After the machine has finished calculating the adjustment amount for the front side, the next screen appears where you can have the machine start reading RSPF adjustment patterns (for the back side).

#### Adjustment Item List

- RSPF original leading edge adjustment (front side)
- RSPF original off-center adjustment (front side)
- RSPF original sub-scan magnification adjustment (front side)

- 8) RSPF adjustment patterns are loaded into the RSPF. (Set so that the pattern surface faces down.)

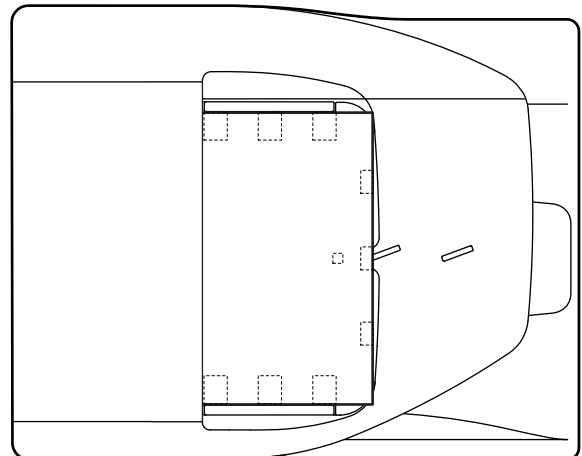

\* By pressing the [REPRINT] key, you can return to the cassette selection screen and have the machine self-print RSPF adjustment patterns again.

- 9) Press the [EXECUTE] key, and the machine starts loading RSPF adjustment patterns (for the back side).

\* The screen shows a message indicating that the machine is reading RSPF adjustment patterns (for the back side).

The machine starts calculating the adjustment amount (for the back side) after it has read the patterns for the back side.

After the machine has finished calculating the adjustment amount for the back side, the next screen appears where you can view the results of the adjustments.

#### <Adjustment Item List>

- RSPF original leading edge adjustment (back side)
- RSPF original off-center adjustment (back side)
- RSPF original sub-scan magnification adjustment (back side)

- 10) The adjustment result screen appears.

This screen shows the current values along with the previous values in parentheses.

\* By pressing the [REPRINT] key, you can return to the cassette selection screen and have the machine self-print RSPF adjustment patterns (for the front and back sides) again.

\* To have the machine start re-reading the RSPF adjustment patterns (front and back sides), press the [RESCAN] key.

\* To return to the top menu without saving the adjustment values into EEPROM and RAM, press the [RETRY] key.

\* To display the data used for adjustment, press the [DATA] key.

- 11) To save the adjustment values into EEPROM and RAM and return to the top menu, press the [OK] key.

\* To return to the result screen, press the [BACK] key.

## ADJ 5 Print engine image distortion adjustment / OPC drum phase adjustment / Color registration adjustment (Print engine section)

This adjustment must be performed in the following cases:

- \* When the color shift occurs.
- \* When the LSU is replaced.
- \* When the LSU is removed from the main unit.
- \* When the unit is installed or when the installing place is changed.
- \* When maintenance work is performed. (Replacement of the OPC drum, the OPC cartridge, the transfer unit, the transfer belt, etc.)
- \* When [ADJ 4A] / [ADJ 16A] Print engine image magnification ratio adjustment (BK) (main scanning direction) is performed.
- \* U2 trouble has occurred.
- \* When the PCU PWB is replaced.
- \* When EEPROM on the PCU PWB is replaced.
- \* When the color phase is not proper even after execution of the color balance adjustment.
- \* When the OPC drum drive section is disassembled.
- \* When the primary transfer unit is replaced. (when it is removed from the machine)
- \* When the developing unit or the OPC drum unit is removed from the machine.

## 5-A Print engine image distortion adjustment (Manual adjustment) / OPC drum phase adjustment (Automatic adjustment) / Color registration adjustment (Automatic adjustment)

This adjustment performs the print engine image distortion adjustment, the OPC drum phase adjustment, and the color registration adjustment simultaneously.

- 1) Enter SIM50-22 mode.

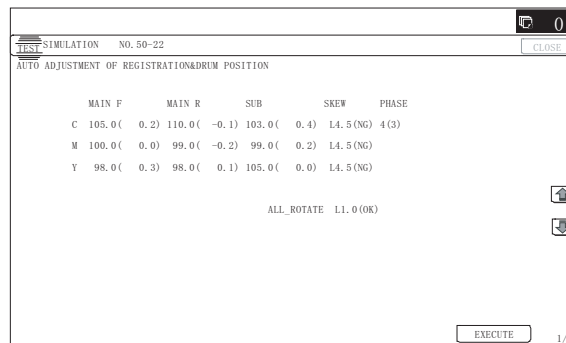

EXECUTE

Adjustment completed

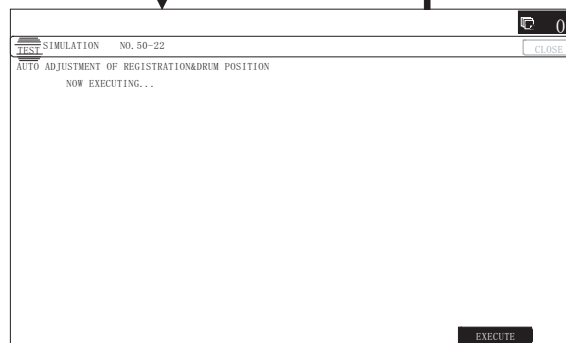

Abnormal end

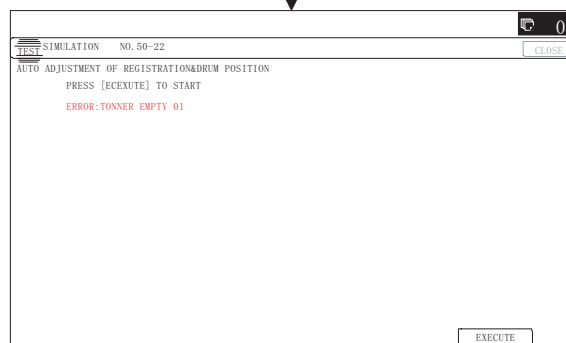

- 2) Press [EXECUTE] key.  
[EXECUTE] key is highlighted and the image registration automatic adjustment is started. (It takes about 15 sec to complete the adjustment.)
- 3) When the adjustment is completed, [EXECUTE] key returns to the normal display, and the value of the adjustment result is displayed.

The current skew level for each color is displayed on the SKEW display section.

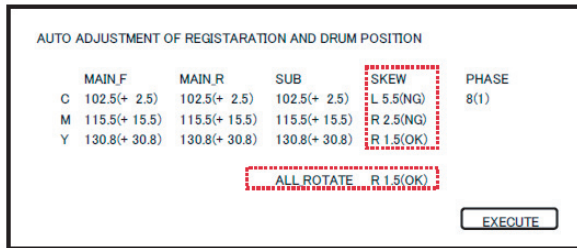

Display/Item	Content	Display	Default	NOTE	
MAIN F	C	Registration adjustment value main scanning direction (Cyan laser writing position F side)	1.0 - 199.0	100	
	M	Registration adjustment value main scanning direction (Magenta laser writing position F side)	1.0 - 199.0	100	
	Y	Registration adjustment value main scanning direction (Yellow laser writing position F side)	1.0 - 199.0	100	
MAIN R	C	Registration adjustment value main scanning direction (Cyan laser writing position R side)	1.0 - 199.0	100	
	M	Registration adjustment value main scanning direction (Magenta laser writing position R side)	1.0 - 199.0	100	
	Y	Registration adjustment value main scanning direction (Yellow laser writing position R side)	1.0 - 199.0	100	
SUB	C	Registration adjustment value sub scanning direction (Cyan drum → Black drum)	1.0 - 199.0	100	
	M	Registration adjustment value sub scanning direction (Magenta drum → Black drum)	1.0 - 199.0	100	
	Y	Registration adjustment value sub scanning direction (Yellow drum → Black drum)	1.0 - 199.0	100	
SKEW	C	Print skew amount calculation result (Cyan)	-99.9 - 99.9	0	If the value is positive (+), "L" is displayed at the head of the value. If negative (-), "R" is displayed. If the value is in the range of -2.1 - +2.1, "(OK)" is displayed at the bottom of the value. In the other cases, "(NG)" is displayed.
	M	Print skew amount calculation result (Magenta)	-99.9 - 99.9	0	
	Y	Print skew amount calculation result (Yellow)	-99.9 - 99.9	0	
ALL_ROTATE	Print skew amount calculation result (Overall)	-99.9 - 99.9	0	If the value is positive (+), "L" is displayed at the head of the value. If negative (-), "R" is displayed. If the value is in the range of -1.6 - +1.6, "(OK)" is displayed at the bottom of the value. In the other cases, "(NG)" is displayed.	
PHASE	OPC drum phase adjustment value	1 - 8	1		

4) Write down the displayed skew level.

**Meaning of the skew level value and the adjustment procedure**

- \* If "OK" is displayed for all items of SKEW ALL\_ROTATE, C, M, and Y, there is no need to perform the adjustment.
  - \* When "R" is displayed at the head of the value, turn the LSU skew adjustment screw clockwise.
  - \* When "L" is displayed at the head of the value, turn the LSU skew adjustment screw counterclockwise.
  - \* The turning amount of the adjustment screw corresponds to each adjustment value. "ALL\_ROTATE" indicates the number of rotations, and C, M, and Y indicate numbers of clicks.
- The display value is rounded at the decimal point.
- \* "ALL\_ROTATES" shows the number of rotations of adjustments for all the adjustment screws. "C, M, and Y (SKEW)" shows the number of adjustment click steps for each adjustment screw of C, M, and Y.

Contents in ( )

MIAN, SUB: Difference from the previous adjustment value of image registration.

Example:

If 105 for this time and 103 for the previous time, it is displayed as 105.0 (+2.0).

SKEW, ALL\_ROTATE: Judgment of the LSU skew adjustment result. OK or NG.

PHASE: OPC drum phase adjustment value of the previous time

5) If the display of ALL\_ROTATE is NG, turn all the LSU skew adjustment screws to adjust, and perform the procedures 2) to 4).

Repeat the procedures 2) to 5) until the display of ALL\_ROTATE becomes OK. If the display of ALL\_ROTATE is OK, go to the procedure 6).

For the adjustment, remove the front cover and the waste toner box, and turn the skew adjustment screw.

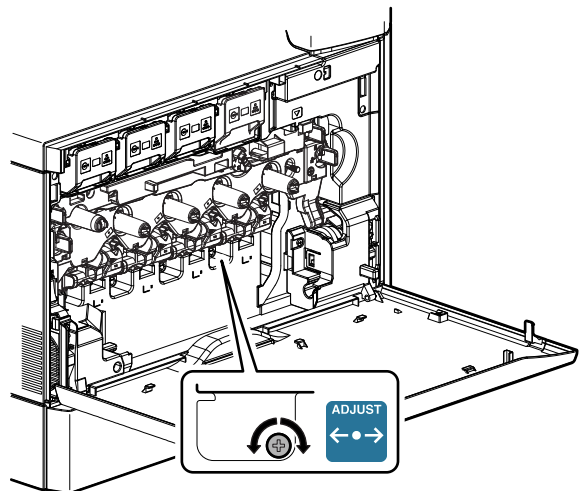

- Repeat the procedures 2) to 4) again, and check to confirm that C, M, and Y (SKEW) are OK.

If any of them is NG, turn the LSU skew adjustment screw of the corresponding color to adjust.

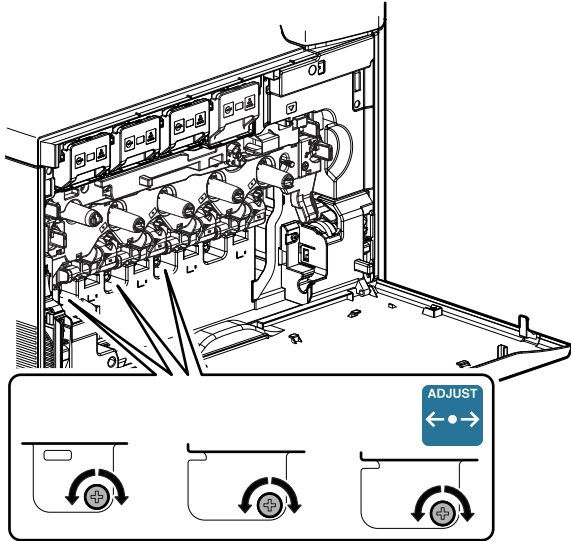

**Important**

When the adjustment is made by turning the LSU skew adjustment screw of K, the states of C, M and Y (SKEW) are changed. Execute SIM50-22 to check to confirm that C, M, and Y (SKEW) are OK. When an abnormality occurs, "ERROR" is displayed. In this case, check each drive section and the process section.

The adjustment result can be checked by the following manual adjustment mode.

- \* ADJ 5B  
Image skew adjustment (Manual adjustment) (SIM50-20)
- \* ADJ 5C  
Color registration offset adjustment (SIM50-20)

**Note**

When the color registration is greatly shifted due to replacement of the LSU, etc, if SIM50-22 is used to perform the color registration automatic adjustment, an error may occur.

In this case, the adjustment may be properly executed by setting the adjustment items A - I of SIM50-20 to "100" and executing the automatic adjustment again.

If color shift in an actual print image differs in the center, the front side, and the rear side, the color shift offset adjustment can improve it. (Refer to ADJ 5C.)

Normally there is a difference in color shift in several dots. Perform the adjustment only when the adjustment is required.

**5-B Print engine image skew (LSU skew) adjustment (Manual adjustment) (No need to adjust normally)**

If a more accurate adjustment than the automatic adjustment ADJ 5A is required, use this method of adjustment.

This adjustment is made by changing the parallelism of the LSU unit scan laser beams for the OPC drum.

- Enter the SIM 50-20 or 64-01 mode.
- Select the paper feed tray with A3 (11" x 17") paper in it, and press [EXECUTE] key.
- The image skew (image registration) adjustment pattern is printed.

- Check the printed black image for any skew. Use the four cross points printed in black to measure the squareness.

There are following two methods of checking the black image for any skew (right angle).

**Method 1**

Measure the distances between opposing corners of the rectangle print pattern, and compare the two distances to check the squareness.

**Method 2**

Check the squareness of the vertical and horizontal sides of the rectangle print pattern by using A3 or 11" x 17" paper sides.

**Important**

In the case of Method 2, the right angle of paper to be used may not be exact. Be sure to check the right angle of paper to be used in advance.

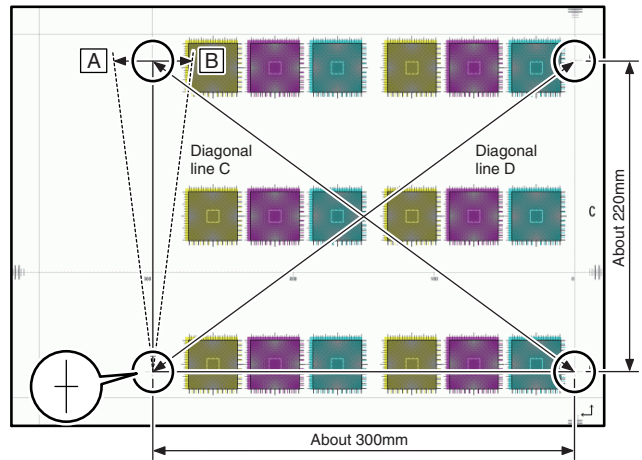

**Method 1**

Measure the length of the diagonal lines of the rectangle print pattern.

Calculate the difference between the measured lengths C and D of the diagonal lines.

Check to insure that the difference between C and D is in the following range.

$$C - D = 0.8\text{mm}$$

If the difference between C and D is in the above range, there is no need to adjust.

**Method 2**

Fit the side of A3 or 11" x 17" paper to the long side of the rectangle print pattern.

Measure the slant (skew) of the vertical side for the horizontal side of paper as shown in the figure.

If the above distance is 0.5mm or less, there is no need to adjust.

If the above condition is not satisfied, perform the following procedure.

- 5) Open the front cover, remove the waste toner box, and turn the four LSU image skew adjustment screws in the same direction by the same amount.

For the adjustment, remove the front cover and the waste toner box, and turn the skew adjustment screw.

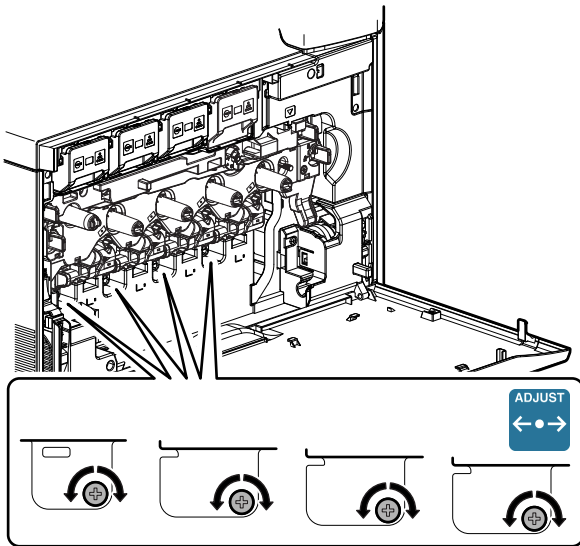

**(Skew adjustment screw rotation direction)**

When C is greater than D in the method 1 or there is some skew in the direction A in the method 2, turn the screw clockwise.

When C is smaller than D in the method 1 or there is some skew in the direction B in the method 2, turn the screw counterclockwise.

**(Reference of the rotation amount of the skew adjustment screw)**

In case of the method 1, 0.8mm/about 1.5 rotations

In case of the method 2, 0.5mm/about 1.5 rotations

Repeat the procedures 2) to 6).

After completion of the black image skew adjustment, go to the procedure 7).

- 6) Perform the same procedures as 1) and 2).  
7) Check the printed color image for any skew.

If the difference between the shift amounts on the F and R sides is within  $\pm 1$  scale of the fine adjustment check scale, there is no need to perform the adjustment.

Measure the skew amount from the print patterns on the front and rear sides of each color.

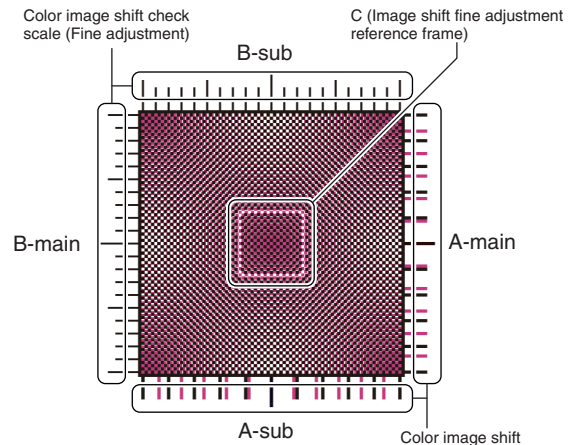
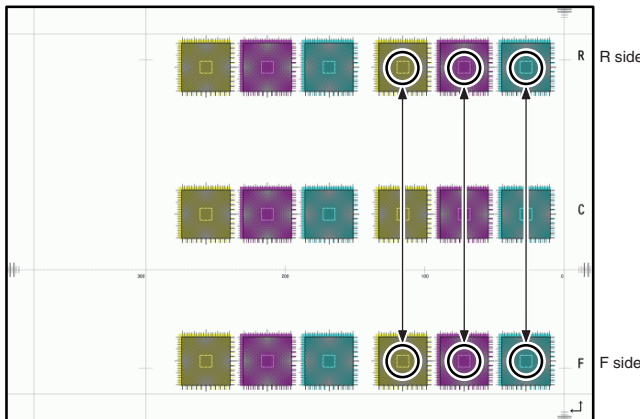

A-main: Main scan rough adjustment pattern  
A-sub: Sub scan rough adjustment pattern  
B-main: Main scan fine adjustment scale  
B-sub: Sub scan fine adjustment pattern  
C: Main scan sub scan fine adjustment pattern

In each Y/M/C color print pattern printed separately in the F side and in the R side, note the same print color pattern and check to confirm that the F side and the R side are in the same condition.

**Rough adjustment pattern check:**

Check the sub scan rough adjustment color image shift check section on the R side and the F side of each color, use the center position of the black scale as the reference, and check the balance in shifts of the color image line positions in the positive and the negative directions. The balance in the R side must be the same as that in the F side.

**Fine adjustment pattern check:**

Check the square frames on the R side and the F side of each color. (Normally five sections of high density can be seen.) Check the sub scanning direction position of the center area of high density (one of the above five sections). These must be on the same position on the R side and the F side.

In this case, use the sub scan direction color image shift check scale (fine adjustment) as the reference.

Visually check the color density and make the darkest section as the center, and use it as the read value of the shift amount.

Check that the difference in the center position of the dark density section is within  $\pm 1$  step.

The positional relations of the front and the rear frame of the print color patterns of a same color are compared. There is no need that all the colors are in the same state. Compare only the positional relations of color patterns of a same color.

If the above condition is not satisfied, perform the following procedure.

- 8) Turn the LSU skew adjustment screw of the adjustment target color to adjust.

**(Skew adjustment screw rotation direction)**

When the F side is skewed to the right side for R side: Turn the screw clockwise.

When the F side is skewed to the left side for the R side: Turn the screw counterclockwise.

**(Reference of the rotation amount of the skew adjustment screw)**

Skew of difference by one step between F and R sides (Difference by one scale of the fine adjustment check scale) / Turn for about 2 clicks.

Repeat the procedures 7) to 8) until a satisfactory result is obtained.

## 5-C Color registration offset adjustment (No need to adjust normally)

This adjustment is used to set the offset value for the automatic color registration adjustment (ADJ 5A).

If there is any difference in color phase at the center and the four corners of an actual print image, this adjustment may improve it. Especially when there is any color shift at the center area, this adjustment may improve it effectively.

This adjustment cannot eliminate color shifts in all the areas, but average the overall color shifts.

After the automatic adjustment, use this color registration offset adjustment to correct color shift partially, performing the adjustment efficiently.

### Note

Before execution of this adjustment, check to confirm that the following adjustment has been properly made.

\* ADJ 5A or ADJ 5B image skew adjustment (LSU unit)

### [Kinds of adjustment values]

There are following two kinds of registration adjustment values.

- Base registration adjustment value: XXX(FRONT)/XXX(REAR)  
They are manual adjustment values and automatic adjustment values, and reflected when the automatic registration adjustment is executed. It varies for every operation of the automatic registration adjustment.
- Offset adjustment values: OFFSETXXF/OFFSETXXR  
They are the offset adjustment values added to the above base registration adjustment values, and are not changed unless SIM50-20 is executed to change.

- 1) Enter SIM50-20 mode.
- 2) Select the paper feed tray with A3 (11" x 17") paper in it.
- 3) Press [EXECUTE] key.  
The color image registration check pattern is printed.

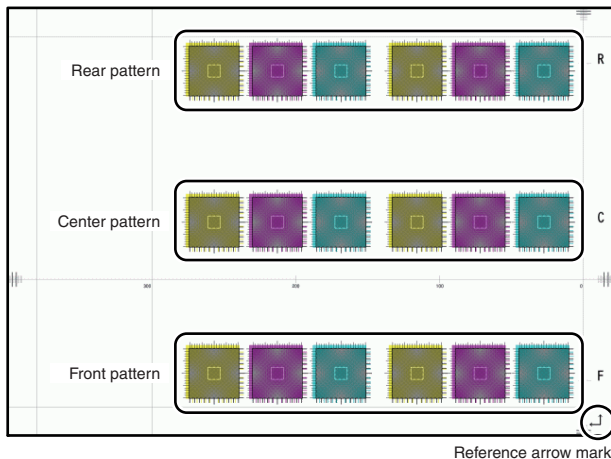

- 4) Check the color image registration.  
There are 6 color image registration patterns in total; two on each of the F side, the R side, and the center. Check all the patterns to confirm that they are within the specified range. Also check to confirm that there is not much shift in each color image registration check pattern.

### Note

There are two kinds of adjustment: one in the main scanning direction and the other in the sub scanning direction. The vertical direction in the above figure is that in the main scanning direction, and the horizontal direction is that in the sub scanning direction.

There are also two kinds of adjustments: the rough adjustment and the fine adjustment. Perform the rough adjustment then perform the fine adjustment deliberately.

For the main scan direction image registration, the offset on the F side, the R side, and at the center is independently adjusted.

If there is a difference in the sub scanning direction image registration between the F and R sides, perform the skew adjustment (ADJ 5A).

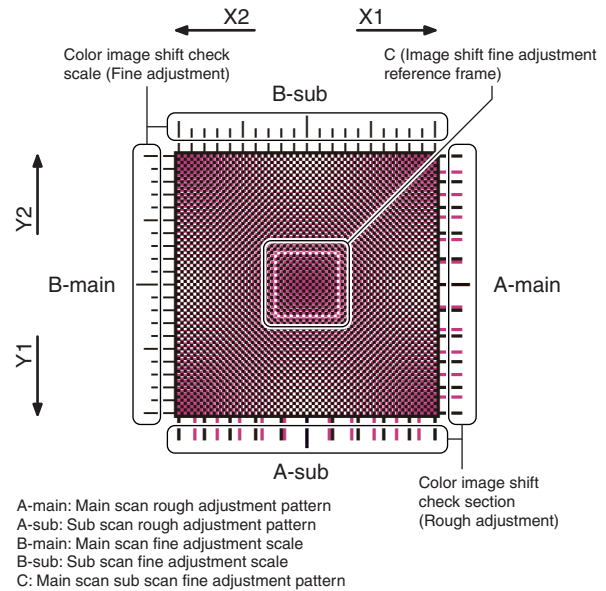

Check the print patterns of the rough adjustment and the fine adjustment of 18 check patterns.

### How to check the rough adjustment pattern and input of the adjustment value:

Visually check the color image registration check section, use the center position of the black scale as the reference, and check the shift balance in the positive and negative directions at the color image line position.

Use the center position of the black scale as the reference, and check that the color image line is symmetrical in the positive side and the negative side.

If shift is in the arrow mark X1 and Y1, increase the adjustment value. If shift is in the arrow mark X2 and Y2, decrease the adjustment value.

The reference arrow on the check pattern faces the positive direction.

### (Reference adjustment value)

1 scale/10 (When the set value is changed by 10, shift is made by 1 scale.)

### How to check the fine adjustment pattern and input of the adjustment value:

Check to confirm that the darkest spot (one of 5 spots seen normally) is within the center area of the image registration adjustment reference frame in the square frame.

At that time, use the color image registration check scale (fine adjustment) as the reference.

Visually check and consider the darkest section of color density as the center, and measure the shift from it.

Check to confirm that the center of the dark density section is within  $\pm 1$  step.

(If the fine adjustment print pattern is in the range of  $0 \pm 1$  for the fine adjustment reference pattern scale, there is no need to adjust.)

If shift is in the arrow mark X1 and Y1, increase the adjustment value. If shift is in the arrow mark X2 and Y2, decrease the adjustment value.



### (Reference adjustment value)

1 scale/1 (When the set value is changed by 1, shift is made by 1 scale.)

If there is a considerable difference in color shift in the square and at the center area, perform the adjustment.

Select an adjustment item (OFF SET X F / OFF SET X R / OFF SET X S), and change the adjustment value to adjust.

OFF SET X F: F side main scanning direction registration offset set value (The color shift on the F side and at the center area is changed.)

OFF SET X D: R side main scanning direction registration offset set value (The color shift on the R side and at the center area is changed.)

OFF SET X S: Sub scanning direction registration offset set value (Color is shifted to the sub scanning direction overall.)

### Important

When the adjustment value of OFF SET X F and OFF SET X R are changed, the color at the center area will be affected. Consider this when executing the adjustment.

### (Adjustment conditions and method)

To adjust evenly overall, adjust so that the color shifts on the F side, the R side and at the center are of the same level.

To adjust with the center area most focused, adjust so that the color shift at the center becomes smaller than that on the F side and the R side.

When the offset adjustment value is 0, if the color registration adjustment (automatic adjustment) is performed, the color shift on the F side and that on the R side are automatically adjusted to be smaller than that on the center area.

Display/Item	Content	Adjustment value range	Default value
A	CYAN (FRONT)	Image registration adjustment value (Main scanning direction) (Cyan) (F side)	1 - 199 100
B	CYAN (REAR)	Image registration adjustment value (Main scanning direction) (Cyan) (R side)	1 - 199 100
C	MAGENTA (FRONT)	Image registration adjustment value (Main scanning direction) (Magenta) (F side)	1 - 199 100
D	MAGENTA (REAR)	Image registration adjustment value (Main scanning direction) (Magenta) (R side)	1 - 199 100
E	YELLOW (FRONT)	Image registration adjustment value (Main scanning direction) (Yellow) (F side)	1 - 199 100
F	YELLOW (REAR)	Image registration adjustment value (Main scanning direction) (Yellow) (R side)	1 - 199 100
G	CYAN (SUB)	Image registration adjustment value (Sub scanning direction) (Cyan)	1 - 199 100
H	MAGENTA (SUB)	Image registration adjustment value (Sub scanning direction) (Magenta)	1 - 199 100
I	YELLOW (SUB)	Image registration adjustment value (Sub scanning direction) (Yellow)	1 - 199 100
J	OFFSET CF	Image registration offset adjustment value (Main scanning direction) (Cyan) (F side)	1 - 199 100
K	OFFSET CR	Image registration offset adjustment value (Main scanning direction) (Cyan) (R side)	1 - 199 100

Display/Item	Content	Adjustment value range	Default value
L	OFFSET MF	Image registration offset adjustment value (Main scanning direction) (Magenta) (F side)	1 - 199 100
M	OFFSET MR	Image registration offset adjustment value (Main scanning direction) (Magenta) (R side)	1 - 199 100
N	OFFSET YF	Image registration offset adjustment value (Main scanning direction) (Yellow) (F side)	1 - 199 100
O	OFFSET YR	Image registration offset adjustment value (Main scanning direction) (Yellow) (R side)	1 - 199 100
P	OFFSET CS	Image registration offset adjustment value (Sub scanning direction) (Cyan)	1 - 199 100
Q	OFFSET MS	Image registration offset adjustment value (Sub scanning direction) (Magenta)	1 - 199 100
R	OFFSET YS	Image registration offset adjustment value (Sub scanning direction) (Yellow)	1 - 199 100

## ADJ 6 Scan image distortion adjustment (Document table mode)

This adjustment must be performed in the following cases:

- \* When the scanner (reading) section is disassembled.
- \* When the copy image is distorted.

### 6-A Scanner (reading) unit parallelism adjustment

Before execution of this adjustment, remove the document table glass.

- 1) Remove the lamp unit, and then loosen the screws which are fixing the scanner unit A and the drive wire. Release the scanner unit A from the drive wire.

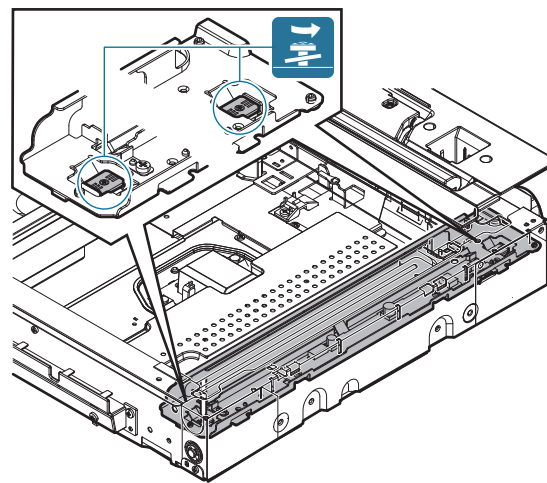

- Turn the scanner drive pulley manually and shift the scanner unit B to bring it into contact with the stopper.

When the scanner unit B is in contact with the two stoppers on the front and the rear frames simultaneously, the parallelism is proper.

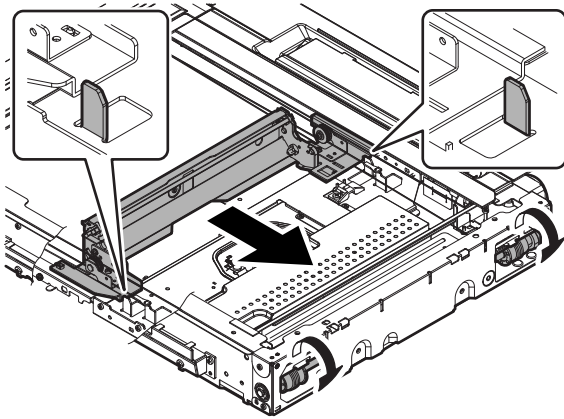

If this requirement is not met, do the following steps.

- Loosen the fixing screw of the pulley angle on the front frame side of the scanner unit B.

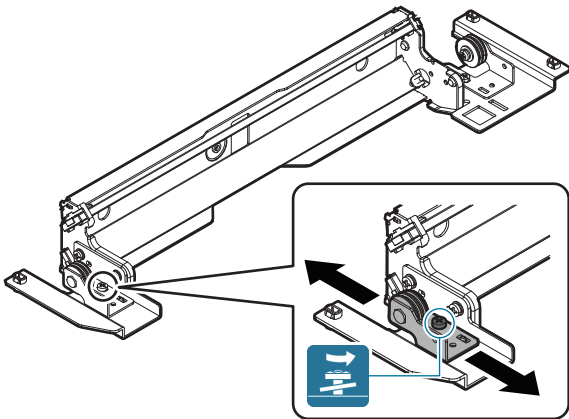

- Adjust the position of the pulley angle on the front frame side of the scanner unit B so that it is in contact with two stoppers on the front and the rear frames simultaneously.
- Fix the pulley angle on the front frame side of the scanner unit B.

If a satisfactory result is not obtained from the above procedures, perform the following procedures.

Loosen the fixing screw of the scanner unit drive pulley which is not in contact.

Without moving the scanner unit drive shaft, turn the scanner unit drive pulley manually and adjust so that the scanner unit B is in contact with both stoppers on the front frame and the rear frame simultaneously. (Change the relative position of the scanner unit drive pulley and the drive shaft.) Fix the scanner unit drive pulley fixing screw.

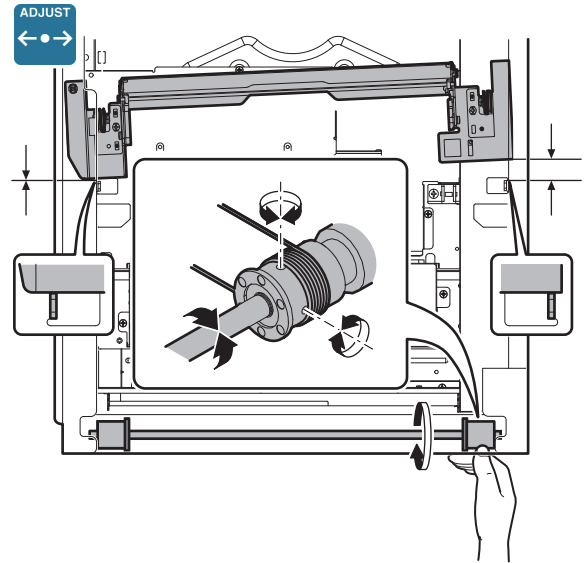

- With the scanner unit B in contact with both stoppers, fit the edge of the scanner unit A with the right edge of the frame, and fix the scanner unit A with the fixing screw.

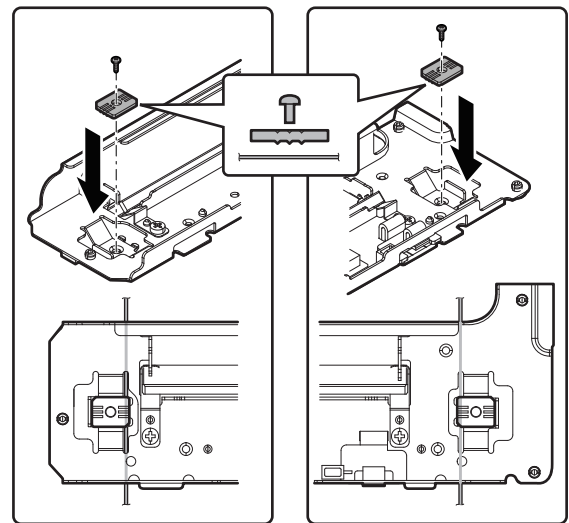

### 6-B Scan image (sub scanning direction) distortion adjustment

- Make a test chart on A3 (11" x 17") paper as shown below. (Draw a rectangular with four right angles.)

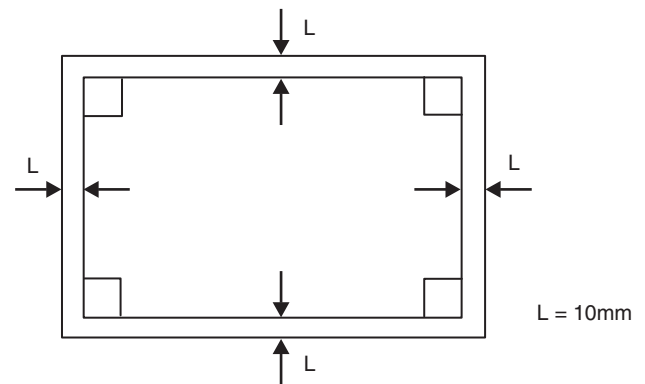

- Set the test chart prepared in the procedure 1) on the document table. (Shift the test chart edge 30mm from the reference position as shown below.) With the document cover open, make a copy on A3 (11" x 17") paper.

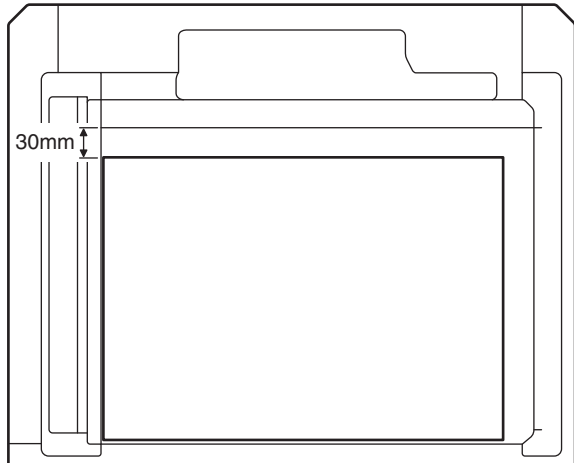

- Check for distortion in the sub scanning direction. If  $L_a = L_b$ , there is no distortion.

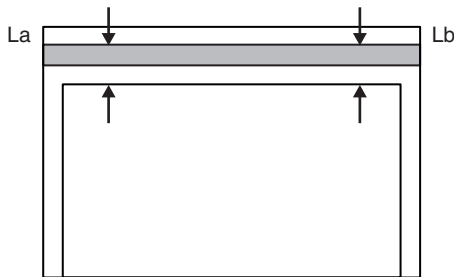

If there is any distortion in the sub scanning direction, perform the following procedures.

- Loosen either one of the fixing screws of the scanner unit drive pulley. (Either one on the front frame or on the rear frame will do.)

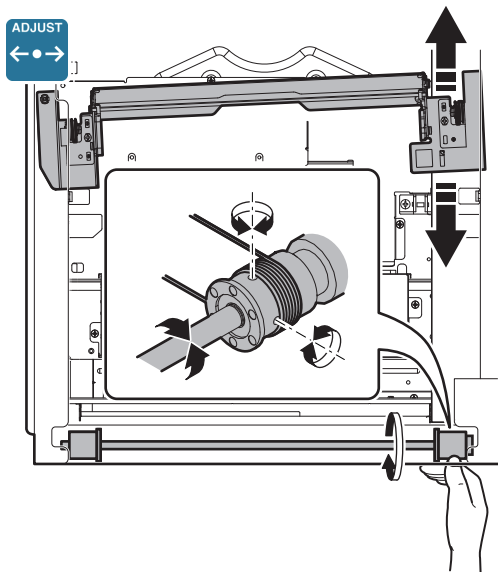

- Without moving the scanner unit drive shaft, manually turn the scanner unit drive pulley to change the parallelism of the scanner unit A and B. (Change the relative position of the scanner unit drive pulley and the drive shaft.)

- Tighten the scanner unit drive pulley fixing screw. Repeat the procedures 2) - 6) until the condition of the procedure 3) is satisfied.

### 6-C Scan image (main scanning direction) distortion adjustment

- Make a test chart on A3 (11" x 17") paper as shown below. (Draw a rectangular with four right angles.)

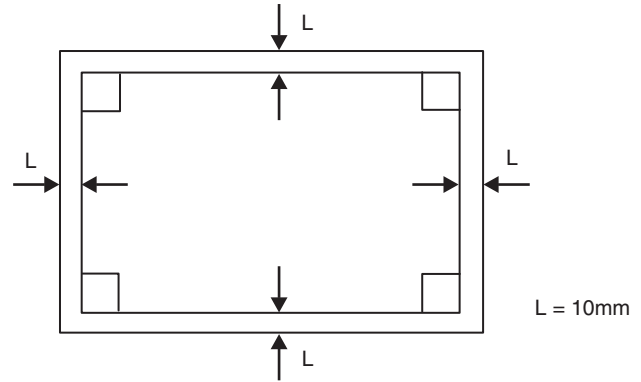

- Set the test chart prepared in the procedure 1) on the document table, and make a copy on A3 (11" x 17") paper.
- Check for distortion in the main scanning direction. If the four angles of the rectangle of the copy image are right angles, it is judged that there is no distortion. (The work is completed.)

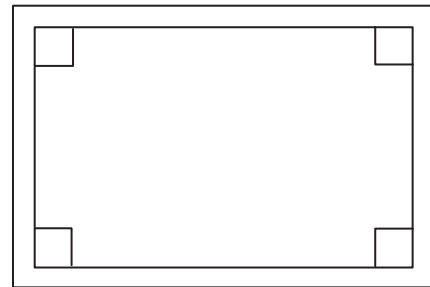

If there is any distortion in the main scanning direction, perform the following procedure.

- Check the difference (distortion balance) between left-hand and right-hand side images.

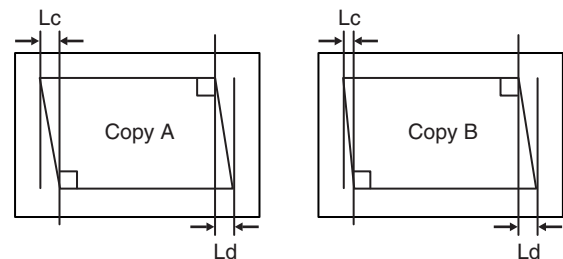

There is no difference between the distortion on the right and that on the left.

$$L_c = L_d$$

There is some difference between the distortion on the right and that on the left.

$$L_c \neq L_d$$

If  $L_c = L_d$ , the distortion on the left is equal to that on the right. (The distortions are balanced.)

If the above condition is satisfied, go to the procedure 6).

If not, perform the following procedures.

- 5) Change the height balance of the scanner rail on the front frame side.

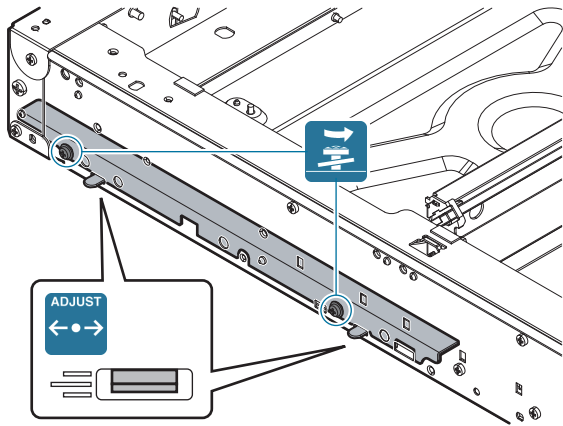

Remove the lower cabinet of the operation panel. Loosen the scanner rail fixing screw to change the balance between the right and the left heights of the scanner rail.

Repeat the procedures 2) - 5) until the difference between the image distortions (distortion balance) is deleted.

- 6) Without changing the balance of the scanner rail on the front frame side, change the overall height.
- 7) Set the test chart prepared in the procedure 1) on the document table, and make a copy on A3 (11" x 17") paper. Check that the distortion in the main scanning direction is within the specified range.  
Repeat the procedures 6) and 7) until the distortion in the main scanning direction is in the specified range.

## ADJ 7 Scanner image skew adjustment (RSPF mode)

This adjustment must be performed in the following cases:

- \* The RSPF section has been disassembled.
- \* When replacing the RSPF unit.
- \* The RSPF unit generates skewed scanned images.

- 1) Create an adjustment chart by printing in duplex mode the self-print pattern (grid pattern) specified in Simulation 64-2.

SIM 64-2 set values

A = 1, B = 1, C = 254, D = 255

Make sure that the print grid pattern is almost in parallel with the paper edges, and apply position marks A and B to the leading and trailing edges of the paper surface lead edge section.

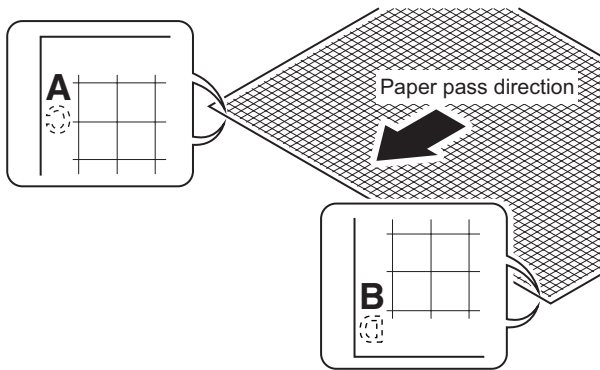

- 2) Copy the adjustment chart (created in step 1) to A3 (11" x 17") paper in RSPF duplex mode, and then check the image for skews (Set in the RSPF feed tray so that the mark on the adjustment chart is at the edge).

- Check with one of the following methods.

### Check Method 1

(Front side)

Make sure that the output satisfies the condition:  $|a-b| \pm 1 \text{ mm}$

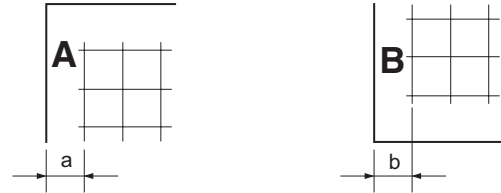

### Check Method 2

Check that the squareness of the main scanning direction print line for the longitudinal direction of paper is within 1.0mm.

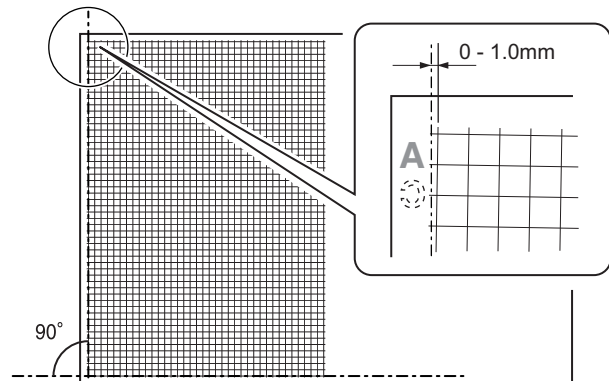

If the copy image is not in the above state, perform the procedure 3).

- 3) Open the RSPF unit, and loosen the fixing screw of the hinge.

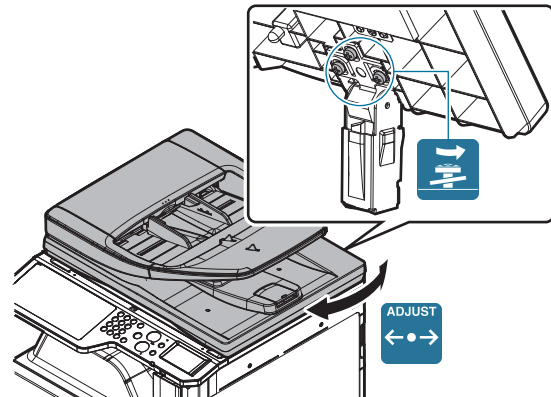

- 4) Slide the RSPF unit in the arrow direction to make the skew adjustment.
- 5) Make a copy again and measure (a) and (b) on the copied test chart. Repeat procedures 2) to 5) until the condition  $((a) - (b)) = \pm 1 \text{ mm}$  or less is satisfied.

## ADJ 8 Scan image focus adjustment

This adjustment must be performed in the following cases:

- \* The CCD unit has been removed from the machine.
- \* The CCD unit has been replaced.
- \* When the copy image focus is not properly adjusted.
- \* When the copy magnification ratio in the copy image main scanning direction is not properly adjusted.
- \* U2 trouble has occurred.

- 1) Enter the SIM 48-1 mode.

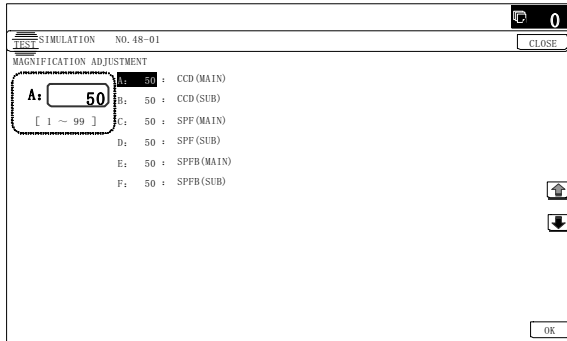

- 2) Set the adjustment item CCD (MAIN) to 50 (default value). Select the adjustment item with the scroll key, and enter the adjustment value with 10-key and press [OK] key.
- 3) Place a scale on the original table as illustrated below.

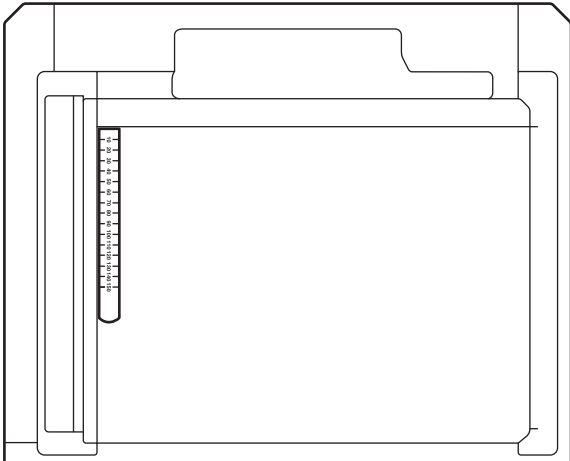

- 4) Make a normal copy on A4 paper. Go to the copy mode, and make a copy.
- 5) Compare the copied image of the scale and the actual scale length in terms of length.

- 6) Obtain the copy magnification ratio correction ratio in the main scanning direction from the following formula.

Main scanning direction copy magnification ratio correction ratio = (Original size - Copy image size) / Original size x 100%

(Example)

Compare the scale of 10mm with the scale of 10mm on the copy image.

Main scanning direction copy magnification ratio correction ratio = (100 - 99) / 100 x 100 = 1

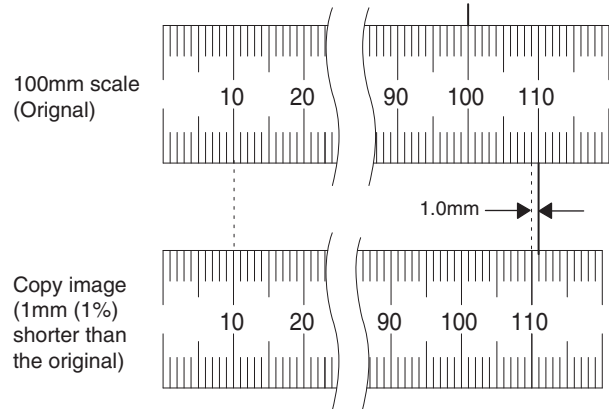

If the copy magnification ratio is not satisfactory, perform the following procedures.

- 7) Remove the document table glass.
- 8) Remove the dark box cover.
- 9) To prevent against shift of the CCD unit optical axis, mark the CCD unit base as shown below.

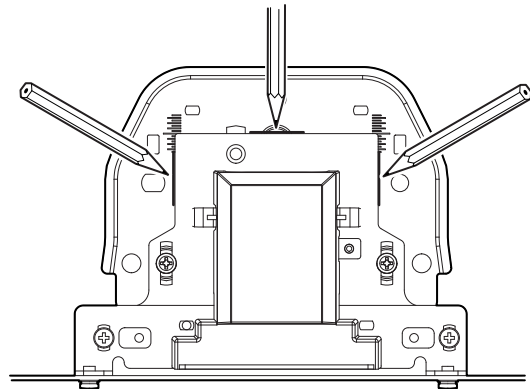

### Note

This procedure must be executed also when the CCD unit is replaced.

10) Loosen the CCD unit fixing screws.

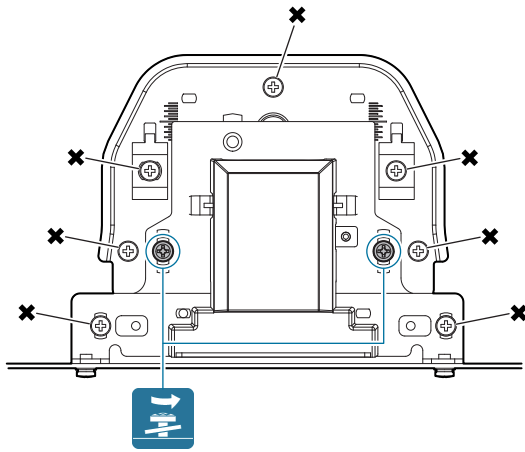

**Important**

Never loosen the screws marked with X.

If any one of these screws is loosened, the position and the angle of the CCD unit base may be changed to cause a problem, which cannot be adjusted in the market. In that case, the whole scanner unit must be replaced.

11) Slide the CCD unit in the arrow direction (CCD sub scanning direction) to change the installing position.

When the copy image is longer than the original scale, shift the CCD unit in the direction B. When the copy image is shorter than the original scale, shift the CCD unit in the direction A.

One scale of mark-off line corresponds to 0.2%.

At that time, fix the CCD unit so that it is in parallel with the scale on the front and the rear side of the CCD unit base.

\* Fix the CCD unit so that it is in parallel with the line marked in procedure 9).

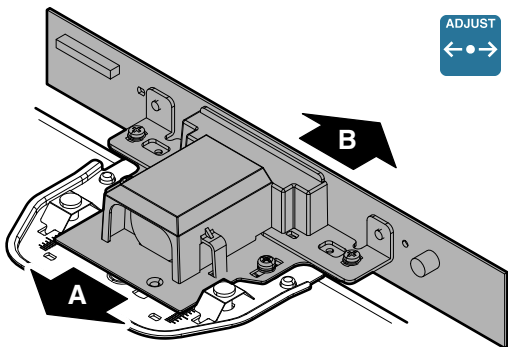

12) Make a copy and check the copy magnification ratio again.

If the copy magnification ratio is not in the range of  $100 \pm 1\%$ , repeat the procedures of 9) - 11) until the condition is satisfied.

**Important**

By changing the CCD unit fixing position with the simulation 48-1 adjustment value at 50, the copy magnification ratio is adjusted within the specified range ( $100 \pm 1.0\%$ ) and the specified resolution is obtained based on the optical system structure.

## ADJ 9 Print lead edge image position adjustment (Printer mode)

This adjustment must be performed in the following cases:

- \* When the registration roller section is disassembled.
- \* When the LSU is replaced or removed.
- \* U2 trouble has occurred.
- \* The PCU PWB has been replaced.
- \* The EEPROM of the PCU PWB has been replaced.

**Note**

This adjustment is performed by the user to increase the lead edge void area to greater than the standard value (3mm) in the printer mode.

1) Enter the SIM 50-5 mode.

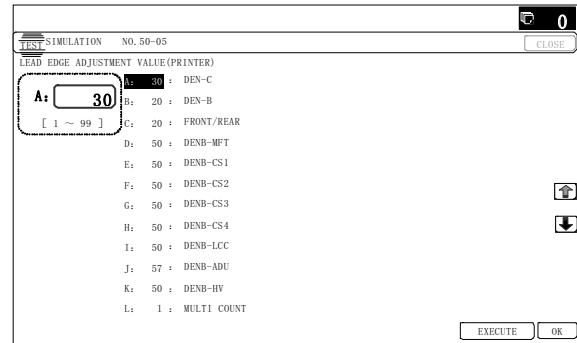

10-key

EXECUTE

EXECUTE

End of print

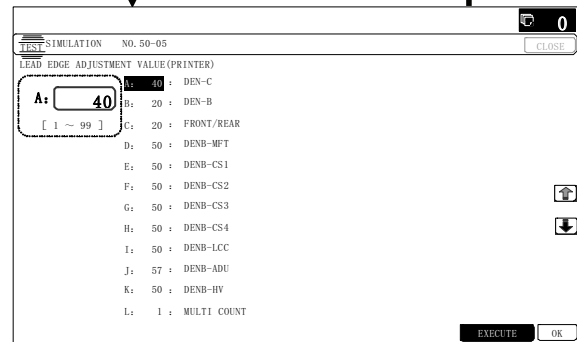

- 2) Select the set item L with the scroll key, and enter the value corresponding to the paper feed tray with A4 (11" x 8.5") paper in it.

Display/Item		Content	Setting range	Default				
A	DEN-C	Printer lead edge image position adjustment	1 - 99	30				
B	DEN-B	Rear edge void area adjustment	1 - 99	30				
C	FRONT/REAR	FRONT/REAR void area adjustment	1 - 99	20				
D	DENB-MFT	Manual feed rear edge void area adjustment correction value	1 - 99	50				
E	DENB-CS1	Tray 1 rear edge void area adjustment correction value	1 - 99	50				
F	DENB-CS2	Tray 2 rear edge void area adjustment correction value	1 - 99	50				
G	DENB-CS3	Tray 3 rear edge void area adjustment correction value	1 - 99	50				
H	DENB-CS4	Tray 4 rear edge void area adjustment correction value	1 - 99	50				
I	DENB-LCC	LCC rear edge void area adjustment correction value	1 - 99	50				
J	DENB-ADU	ADU rear edge void area adjustment correction value	1 - 99	50				
K	DENB-HV	Heavy paper correction value	1 - 99	50				
L	MULTI COUNT	Number of print	1 - 999	1				
M	PAPER	MFT	Tray selection	Manual paper feed	1 - 5	1	2 (CS1)	
		CS1		Tray 1				2
		CS2		Tray 2				3
		CS3		Tray 3				4
		CS4		Tray 4				5
N	DUPLEX	YES	Duplex print selection	Yes	0 - 1	0	1 (NO)	
		NO		No				1

- 3) Press [EXECUTE] key.  
The adjustment pattern is printed.
- 4) Measure the distance from the paper lead edge the adjustment pattern to the image lead edge, and check to confirm that it is in the standard adjustment value range.  
Standard adjustment value:  $4.0 \pm 1.0\text{mm}$

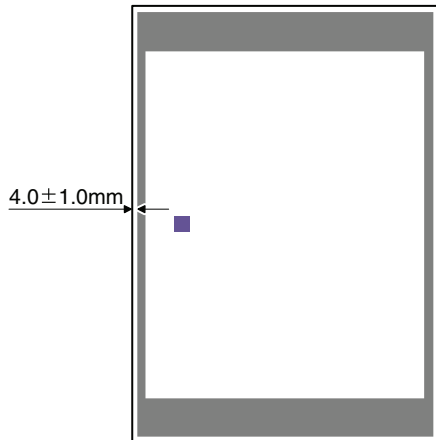

If the above requirement is not met, do the following steps.

- 5) Select the adjustment target of the paper feed mode adjustment item DENC with the scroll key.
- 6) Change the adjustment value.  
Enter the adjustment value and press the [OK] key or the [EXECUTE] key.  
When [EXECUTE] key is pressed, the adjustment pattern is printed.  
When the adjustment value is increased, the distance from the paper lead edge to the image lead edge is increased. When the adjustment value is decreased, the distance is decreased.  
When the set value is changed by 1, the distance is changed by about 0.1mm.
- Repeat the procedures 4) - 6) until the condition of 4) is satisfied.

## ADJ 10 Color balance/density adjustment

### (1) Note before execution of the color balance/density adjustment

- \* Requisite conditions before execution of the color balance/density adjustment

Before execution of the color balance/density adjustment, check to insure that the adjustments which affect the color balance/density have been completed properly.

The importance levels of them are shown below.

**(Since the following items affect the color balance/density directly, they must be adjusted or set before execution of the image quality adjustments.)**

- 1) The following adjustment items must be adjusted properly.

Job No	Adjustment item		Simulation
ADJ 3	Image density sensor adjustment	ADJ 3A Image density sensor calibration	44-13
ADJ 5	Print engine image distortion adjustment / OPC drum phase adjustment / Color registration adjustment (Print engine section)		50-22/20

**(Though the following items affect the color balance/density, there is no need to adjust them frequently. When, however, a trouble occurs, they must be checked and adjusted.)**

- 1) The following items must be adjusted properly.

Job No	Adjustment item		Simulation
ADJ 1	Adjust the developing unit	ADJ 1A Adjust the developing doctor gap	
		ADJ 1B Adjust the developing roller main pole position	
		ADJ 1C Toner density control reference value setting	25-2
ADJ 2	Adjusting high voltage values	ADJ 2A Adjust the main charger grid voltage	8-2
		ADJ 2B Adjust the developing bias voltage	8-1
		ADJ 2C Transfer current and voltage adjustment	8-6
ADJ 8	Scan image focus adjustment		48-1

### Note for the color balance/density check and adjustments

- For the color balance adjustments, be sure to use the paper specified for color (recommended paper).  
Note that, if another kind of paper is used for the color balance adjustment, proper image qualities (color balance, density) may not be obtained.
- When setting the adjustment pattern on the document table in the automatic color balance adjustment procedures, place 5 sheets of white paper on the adjustment pattern in order to prevent back copying and adverse effects of paper wrinkles as far as possible.

### (2) Relationship between the servicing job contents and the color balance/density check and adjustment

Note that the jobs before and after execution of the color balance/density check and adjustment depend on the machine status and the servicing conditions.

Follow the flowchart of the color balance/density adjustment procedures depending on the actual conditions.

There are following four, major cases.

- When installing (When a printer option is installed)
- When a periodic maintenance is performed.
- When a repair, an inspection, or a maintenance is performed. (When a consumable part is replaced.)
- When an installation, a repair, or inspection is performed. (Without replacement of a consumable part)

### (3) Copy color balance and density check

**Important**

Before checking the copy color balance and density, be sure to execute the following jobs.

- \* Execute the high density image correction (Process correction) forcibly. (SIM 44-6)
- \* Execute the half-tone image correction forcibly. (SIM 44-26)

#### Method 1

Make a copy of the gray test chart (UKOG-0162FCZZ) and a copy of the servicing color test chart (UKOG-0326FCZZ/UKOG-0326FC11), and check that they are proper.

#### a. Note for execution of the color balance and density check in the color copy mode

To check the copy color balance and density, use the gray test chart (UKOG-0162FCZZ) and the servicing color test chart (UKOG-0326FCZZ/UKOG-0326FC11). Set the copy density level to "3" in the Text/Printed Photo mode (Manual), and make a copy.

At that time, all the color balance adjustments in the user adjustment mode must be set to the default (center).

In addition, be sure to use the specified paper for color.

#### b. Note for checking the monochrome copy mode density

To check the density, use the gray test chart (UKOG-0162FCZZ). Set the copy density level to "Manual 3" in the Text/Printed Photo mode (Manual).

In addition, all the color balance adjustments in the user adjustment mode must be set to the default (center).

### Check with the gray test chart (UKOG-0162FCZZ)

In the copy density check with the gray test chart, check to insure the following conditions.

**Important**

For the color (gray) balance, use the servicing color test chart (UKOG-0326FCZZ/UKOG-0326FC11) to check.

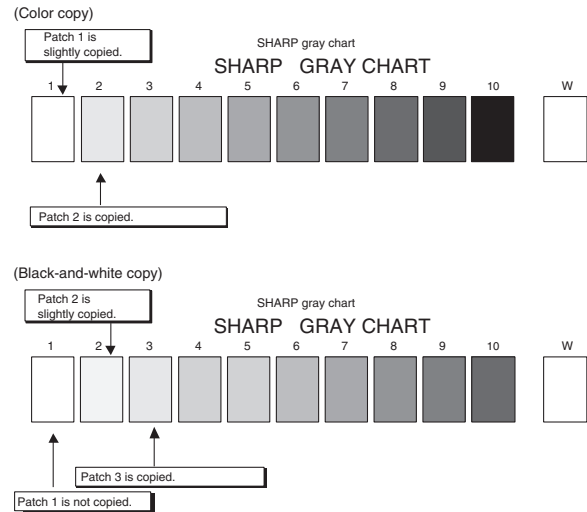

### Check with the servicing color test chart (UKOG-0326FCZZ/UKOG-0326FC11)

In the copy color balance check with the servicing color test chart, check to insure the following conditions.

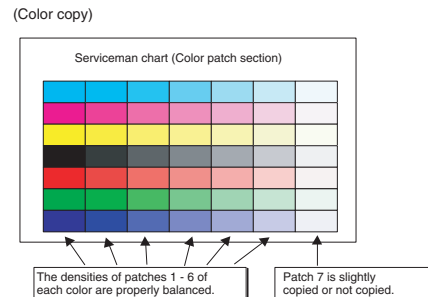



**a. Color copy check items (Check to confirm the following:)**

- 1) There are 12 void areas.
- 2) Registrations (one point for the main scanning, and one point for the sub scanning) are not shifted.
- 3) The resolution of 5.0 (5 points) can be seen.
- 4) The color difference in gray balance between the F and the R sides is not so great.
- 5) There are no white and black streaks.
- 6) Color texts are clearly reproduced.
- 7) The background density is not so light.

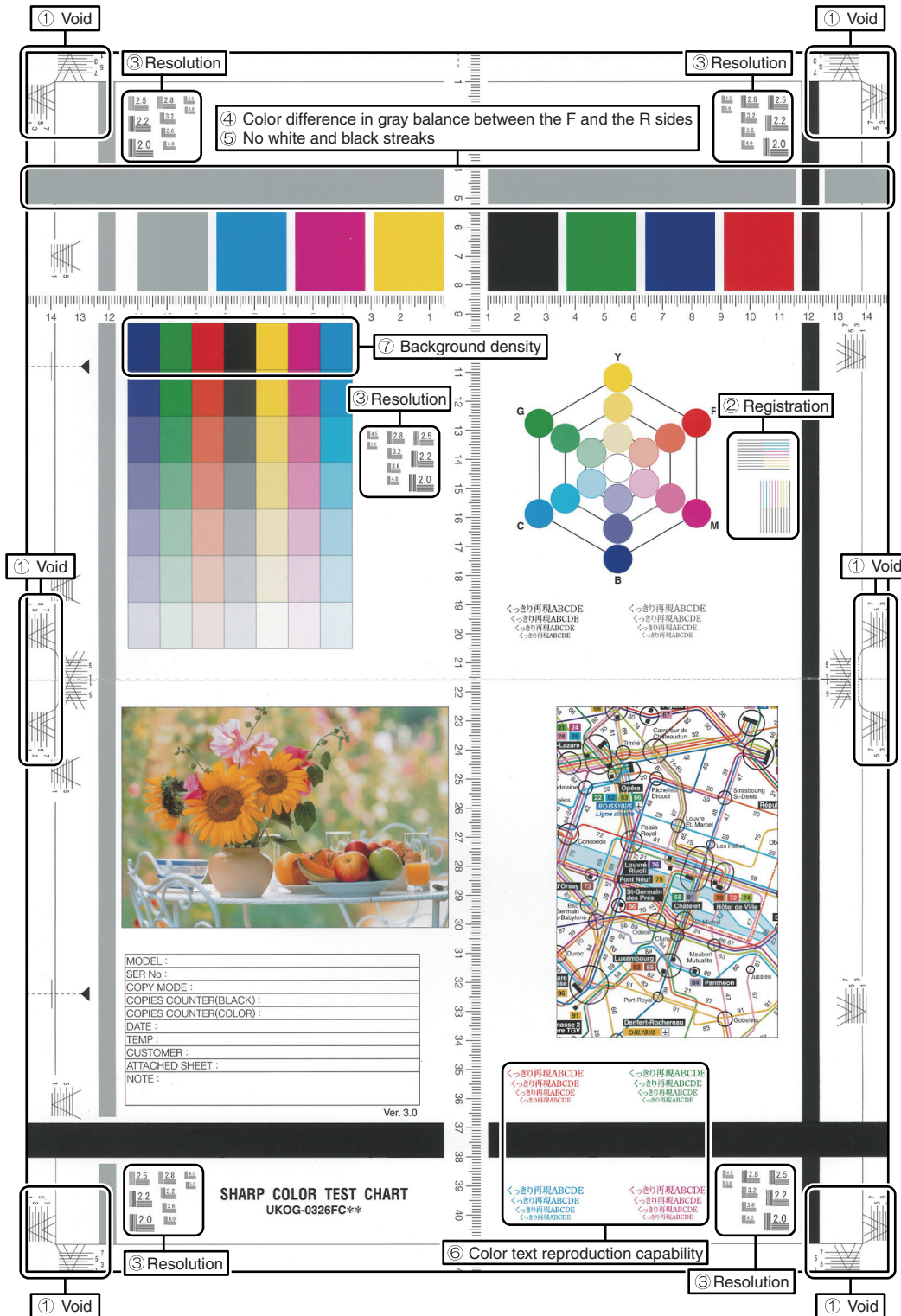

**b. Monochrome copy check items (Check to confirm the following):**

- 1) There are 12 void areas.
- 2) The resolution of 4.0 (5 points) can be seen.
- 3) The density difference between the F and the R sides is not so great.
- 4) There are no white and black streaks.
- 5) The background density is not so light.
- 6) The black low-density gradation is copied slightly.

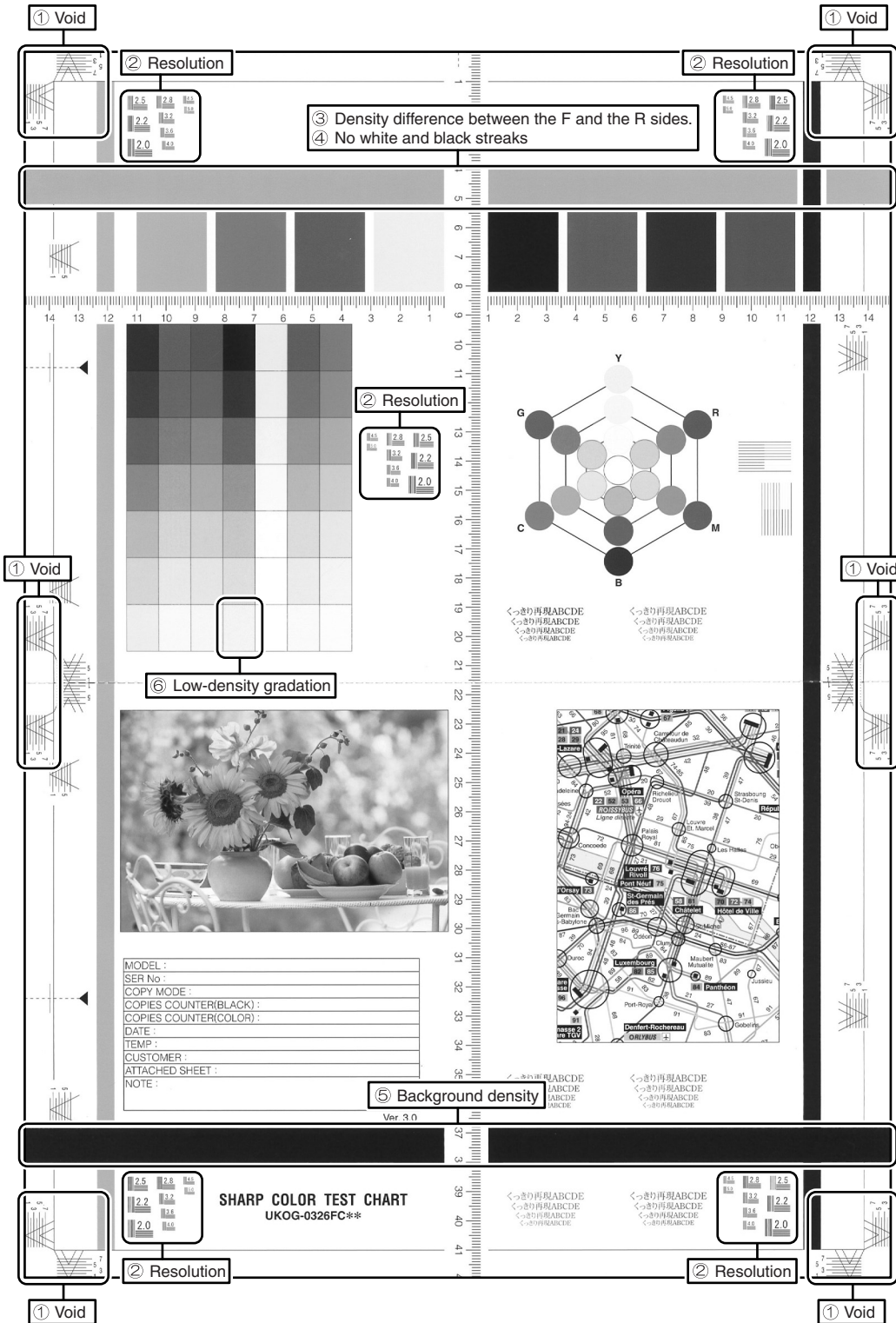

### (Method 2)

Use SIM46-21 to print the color balance adjustment sheet, and check each process (CMY) black patch color balance and the black patch in order to confirm that the color balance adjustment is proper or not more precisely.

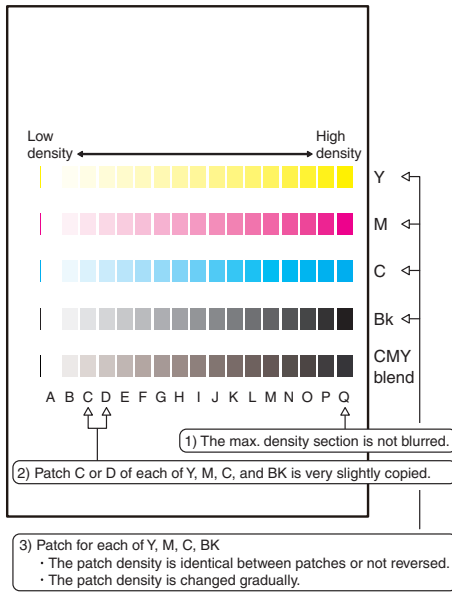

If the color balance of each patch of the process black (CMY mixed color) is slightly shifted to Magenta, it means that the adjustment is proper. If the color balance of the adjustment pattern printed in this mode is slightly shifted to Magenta, it is converted into the natural gray color balance by the color table in an actual copy mode. (When the color balance target is DEF 1.)

### (4) Printer color balance/density check

**Important**

Before checking the copy color balance and the density, be sure to execute the following procedures in advance.

- \* Execute the high density image correction (Process correction) forcibly. (SIM 44-6)
- \* The half-tone image correction is forcibly executed. (SIM 44-26)

### (Method 1)

Execute SIM 64-5 to print the print test pattern.

**Important**

When the PCL or the PS printer function is not provided (GDI model), this method cannot be used for check.

Set each set value to the default and press [EXECUTE] key. The print test pattern is printed.

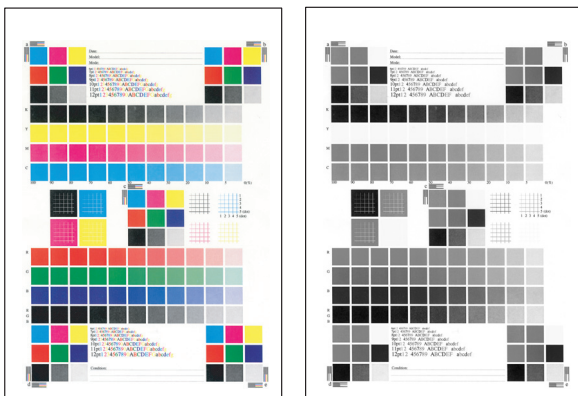

The print density must be changed gradually from the lighter level to the darker level. The density changing direction must not be reversed. The density level of each color must be almost at the same level.

### (Method 2)

When the PCL or the PS printer function is not provided (GDI model), use this method for check.

Use SIM 67-25 to print the color balance adjustment sheet and compare each process (CMY) black patch color balance and the black patch to check the color balance.

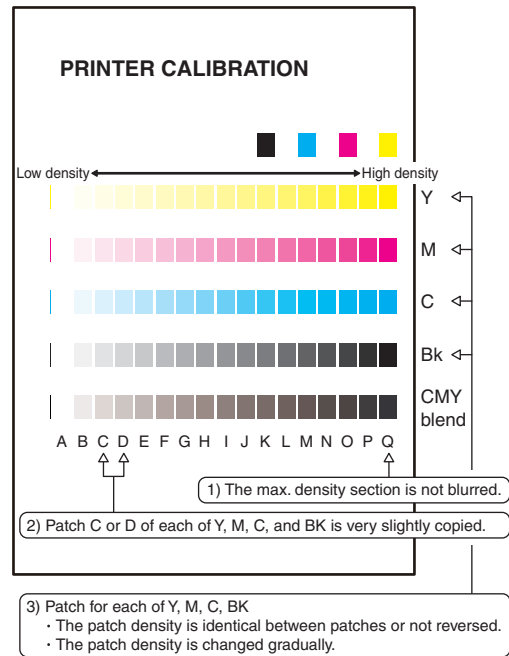

The print density must be changed gradually from the lighter level to the darker level. The density changing direction must not be reversed.

The density level of each color must be almost at the same level.

Patch B may not be copied.

Patch A must not be copied.

If the color balance of each patch of the process black (CMY mixed color) is slightly shifted to Magenta, it means that the adjustment is proper. In an actual print mode, it is converted into the natural gray color balance by the color table. (When the color balance target is DEF 1.)

## 10-A Scanner calibration (CCD calibration)

This adjustment must be performed in the following cases:

- \* When the CCD unit is replaced.
- \* When a U2 trouble is occurred.
- \* When the scanner control PWB is replaced.
- \* When the EEPROM on the scanner control PWB is replaced.

### (1) Note before adjustment

- Check that the table glass, No. 1, 2, 3 mirrors, and the lens surface are free from dirt and dust. (If there is some dust and dirt, wipe and clean with alcohol.)
- Check to confirm that the patches in BK1 and BK2 arrays of the SIT chart (UKOG-0280FCZZ or UKOG-0280FCZ1) are free from dirt and scratches. If they are dirty, clean them. If they are scratched or streaked, replace with new one.

## (2) Adjustment procedures

- 1) Set the SIT chart (UKOG-0280FCZZ or UKOG-0280FCZ1) to the reference position on the left rear frame side of the document table.

Set the chart so that the lighter density side of the patch is on the left side.

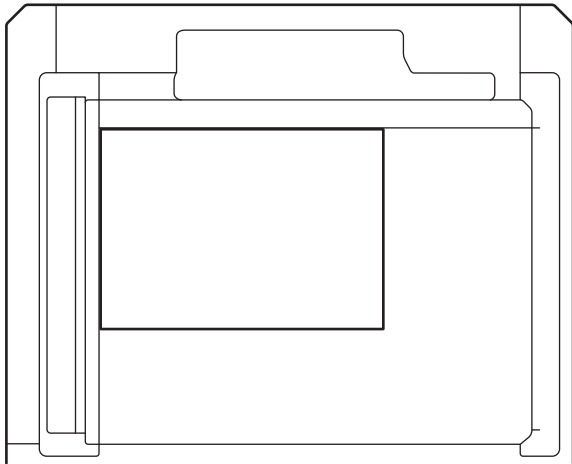
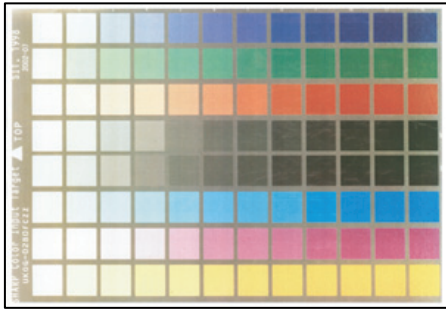

If the SIT chart is not available, execute SIM 63-5 to set the CCD gamma to the default. In this case, however, the adjustment accuracy is lower when compared with the adjustment method using the SIT chart.

### Important

Check to insure that the SIT chart (UKOG-0280FCZZ or UKOG-0280FCZ1) is in close contact with the document table.

### Note

UKOG-0280FCZZ is equivalent to UKOG-0280FCZ1.

- 2) Enter the SIM 63-3 mode and press [EXECUTE] key. The automatic operation is started. During the adjustment, [EXECUTE] is highlighted. After completion of the adjustment, [EXECUTE] returns to the normal display.

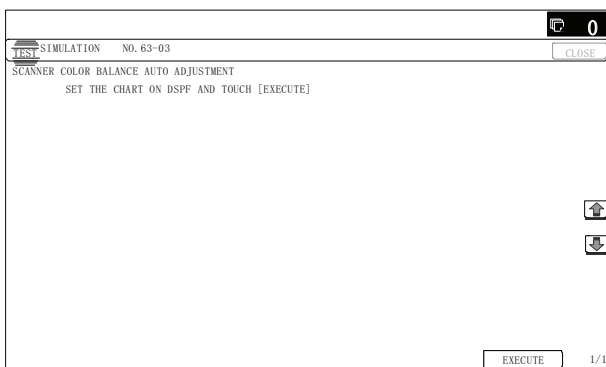

### Note

Since the SIT chart (UKOG-0280FCZZ or UKOG-0280FC Z1) is easily discolored by sunlight (especially ultraviolet rays) and humidity and temperature, put it in a bag (such as a dark file) and store in a dark place of low temperature and low humidity.

## SET 1 Color balance adjustment target setup

### a. General

When the automatic color balance adjustment is executed, a certain color balance (gamma) is used as the target.

There are following three kinds of the target.

- Factory color balance (gamma) target
- Service color balance (gamma) target
- User color balance (gamma) target

In the above three, only the service color balance target can be set to a desired level.

This setting is required in the following cases.

- \* When the color balance and density adjustments are executed manually (SIM46-21) (SIM67-25)
- \* U2 trouble has occurred.
- \* When the MFP PWB is replaced.
- \* When the EEPROM on the MFP PWB is replaced.
- \* The scanner control PWB has been replaced.
- \* The EEPROM on the scanner control PWB has been replaced.
- \* When the user requests for customizing the color balance.
- \* When the service color balance target gamma is judged as improper.

### SET 1A Copy color balance adjustment target setup

- Each color balance target for the copy color balance adjustment

Type	Descriptions
A Factory color balance (gamma) target	There are three kinds of the color balance target, and each of them is specified according to the machine design. Use SIM 63-11 to select one of them as the factory target. The default setting (factory setting) is the color balance (DEF1) which emphasizes color reproduction.
B Service color balance (gamma) target	This target is used when the user requests to customize the color balance to user's desired level. In advance, the user's unique color balance must be registered as the service color balance target. The above registration (setting) is made by the serviceman with SIM 46-21 to adjust the color balance and with SIM 63-7 to register it. This color balance target is used when the user executes the color balance adjustment. When, therefore, the service color balance target is changed, the color balance target of the user's color balance adjustment is also changed. When, however, SIM 63-8 is executed, the color balance is set to the factory color balance target set with SIM 63-11. The default setting (factory setting) of the color balance is same as the factory color balance target. (Emphasized on color reproduction (DEF1)) If the user does not request for customizing the color balance, be sure to use SIM 63-8 to set the color balance to the factory color balance target.
C User color balance (gamma) target	Same color balance as the service color balance (gamma) target When the service color balance target is changed, this color balance target is also changed accordingly.

- Relationship between the factory target and the service target and the color balance target for the user color balance adjustment in the copy color balance adjustment (Automatic adjustment) (SIM 46-74/46-24)

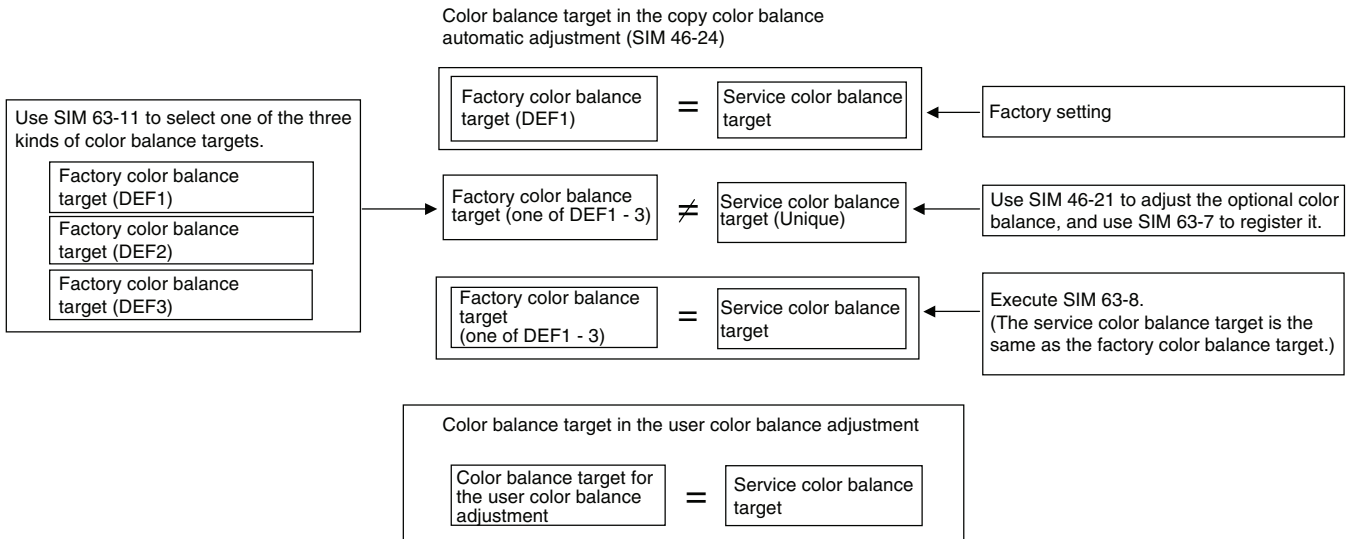

- Factory target in the copy color balance adjustment (SIM 46-74/46-24)  
By use of SIM 63-11, one of the following color balances can be set as the factory color balance target.  
Each of the three color balances cannot be changed. (Fixed)

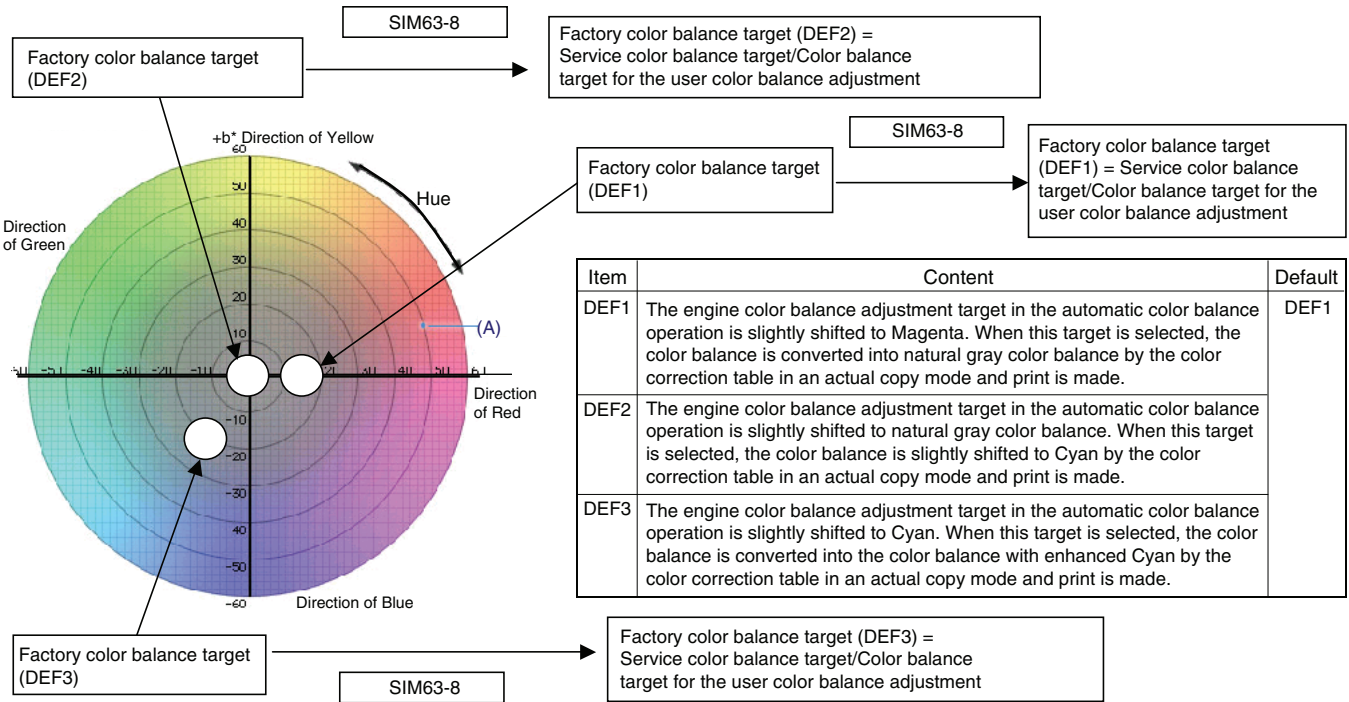

- Service color balance target in the copy color balance adjustment ((Automatic adjustment) SIM 46-74/46-24).  
For the service color balance target, an optional color balance can be adjusted with SIM 46-21 and registered with SIM 63-7. When, however, SIM 63-8 is executed, the color balance is set to the same balance as the factory color balance target set with SIM 63-11.
- Color balance target in the user color balance adjustment  
This color balance is same as the service color balance target in the copy color balance adjustment (Automatic adjustment) (SIM 46-74/46-24). When, therefore, the service color balance target is changed, this target is also changed accordingly.

(Meaning of the service color balance target gamma data and the purpose of registration)

This procedure must be executed only when the color balance is customized with SIM 46-21.

If the color balance is not customized, this procedure is not required.

After completion of the customized color balance adjustment (Manual) with SIM 46-21 according to the user's request, use SIM 63-7 to register the service color balance target data by using adjustment pattern that was printed in this mode.

**Important**

In this case, be sure to use A4 or 11" x 8.5" paper for printing the adjustment pattern by SIM 46-21.

By this procedure, the service color balance target is revised.

It is recommended to keep the printed adjustment pattern created with SIM 46-21. This adjustment pattern can be used to register the same color balance target to another machine.

It is also useful to register the service color balance target data. Do not fold it and keep it under the circumstances which protect it from discoloration and dirt.

The service color balance target data is registered immediately after the color balance adjustment (Manual) with SIM 46-21.

If a considerable time has passed after completion of the color balance adjustment (Manual) with SIM 46-21, the color balance of the adjustment pattern at the time of adjustment differs from the color balance of the adjustment pattern printed after a considerable time. Never use such a pattern for the adjustment.

The accuracy of the service color balance target data can be judged as follows.

When result of the color valance adjustment (Auto) with selecting the service color balance target in SIM 46-74/46-24 is unsatisfactory or abnormal.

In that case, the registered service target data for the color balance adjustment (Auto) may be improper.

This may be caused when an improper or abnormal color balance adjustment pattern was used to register the service color balance target data for the color balance adjustment with SIM 63-7.

The color balance adjustment pattern used in registration was made and printed by the color balance adjustment (Manual) with SIM 46-21. This procedure may have been executed erroneously

### a. Setting procedure

(Setting procedure of an optional color balance (gamma) as the service color balance target)

- 1) Use SIM 46-21 (Copy color balance adjustment (manual adjustment) mode) to print two sheets of the color patch image (adjustment pattern).

#### Important

In this case, be sure to use A4 or 11" x 8.5" paper for printing the adjustment pattern by SIM 46-21.

If the color balance is shifted from the standard, an adjustment is required. If not, an adjustment is not required. When an optional color balance is requested by the user, make an adjustment.

- 2) Enter the SIM 63-7 mode.

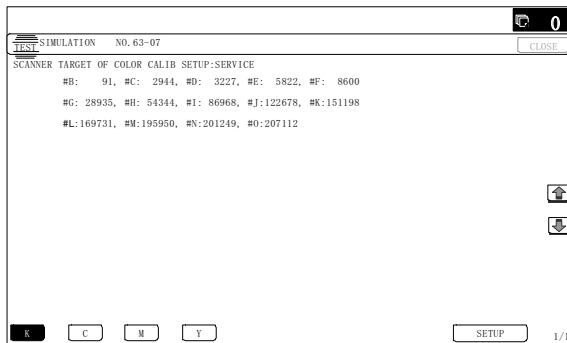

- 3) Press [SETUP] key.
- 4) Set the color patch image (adjustment pattern) correctly adjusted and printed in the copy color balance adjustment (Manual adjustment) (SIM 46-21) (ADJ 10C (2)) on the document table.

The color patch image (adjustment pattern) printed with SIM 64-7 can be used instead. In this case, however, check that the printed pattern is normal.

(When the color patch image (adjustment pattern) is printed by SIM 64-7, set the item B (PROC ADJ) to "0 (YES)" and press [EXECUTE] key to print.)

A color patch image (adjustment pattern) printed by another machine can be used.

Set the pattern so that the light density side is on the left side. Place 5 sheets of white paper on the color patch image (adjustment pattern).

If the color balance could not be adjusted satisfactorily with SIM 46-21 (Color balance adjustment (Manual)), do not execute SIM 63-7 to register the service color balance target data.

- 5) Press [EXECUTE] key.

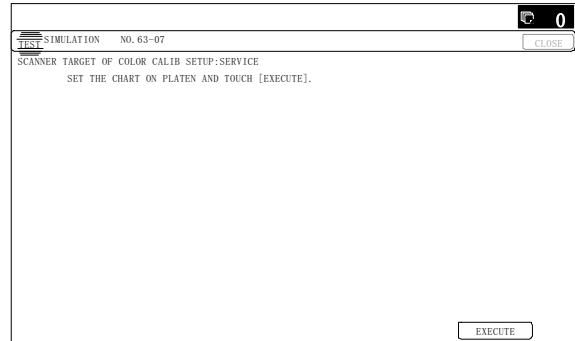

The color patch image (adjustment pattern) is read.

- 6) Press [REPEAT] key, set the second color patch image (adjustment pattern), and execute the procedure 5) again.

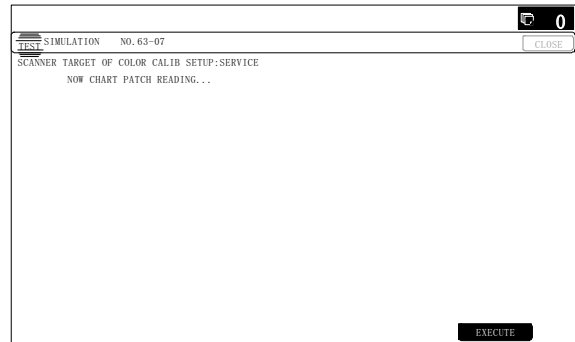

The color balance (gamma) target set level of each color (KCMY) can be checked with K/C/M/Y keys.

Check that the set level is increased in the sequence of B - Q (MAX). If there is no variation or variation is reversed, it is judged as abnormal.

In case of an abnormality, repair the problem and try again.

- 7) Press [OK] key.

The color balance (gamma) of the color patch image (adjustment pattern) used in the procedure 5) is set as the service target.

**(Procedures to set the service color balance target and the color balance target for the user color balance adjustment to the same color balance as the factory color balance target)**

#### Important

This procedure must not be executed when the copy color balance was adjusted with SIM 46-21 to a unique color balance requested by the user and it was registered as the service color balance target with SIM 63-7.

When the factory color balance target is changed with SIM 63-11, be sure to execute this procedure.

1) Enter the SIM 63-8 mode.

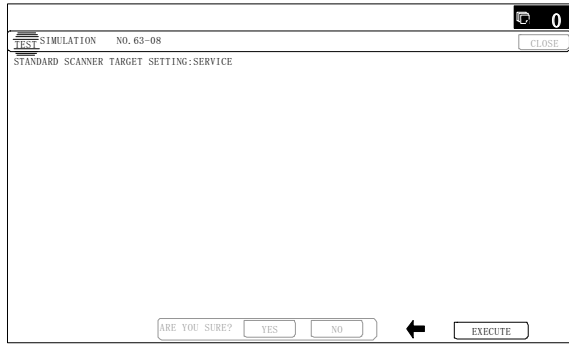

2) Press [EXECUTE] key.

3) Press [YES] key.

The service color balance target and the color balance target for the user color balance adjustment are set to the same color balance as the factory color balance target.

### SET 1B Printer color balance adjustment target setup

- Color balance target for the printer color balance adjustment

Type	Descriptions
A Factory color balance (gamma) target	There are three kinds of the color balance targets, and each of them is specified according to the machine design. Use SIM 67-26 to select one of them as the factory target. The default setting (factory setting) is the color balance (DEF1) which emphasizes color reproduction.
B Service color balance (gamma) target	This target is used when the user requests to customize the color balance to user's desired level. In advance, the user's unique color balance must be registered as the service color balance target. The above registration (setting) is made by the serviceman with SIM 67-25 to adjust the color balance and with SIM 67-27 to register it. This color balance target is used when the user executes the color balance adjustment. When, therefore, the service color balance target is changed, the color balance target of the user's color balance adjustment is also changed. When, however, SIM 67-28 is executed, the color balance is set to the factory color balance target set with SIM 67-26. The default setting (factory setting) of the color balance is same as the factory color balance target. (Emphasized on color reproduction (DEF1)) If the user does not request for customizing the color balance, be sure to use SIM 67-28 to set the color balance to the factory color balance target.
C User color balance (gamma) target	Same color balance as the service color balance (gamma) target When the service color balance target is changed, this color balance target is also changed accordingly.

- Relationship between the factory target and the service target and the color balance target for the user color balance adjustment in the printer color balance adjustment (Automatic adjustment) (SIM 46-74/76-24)

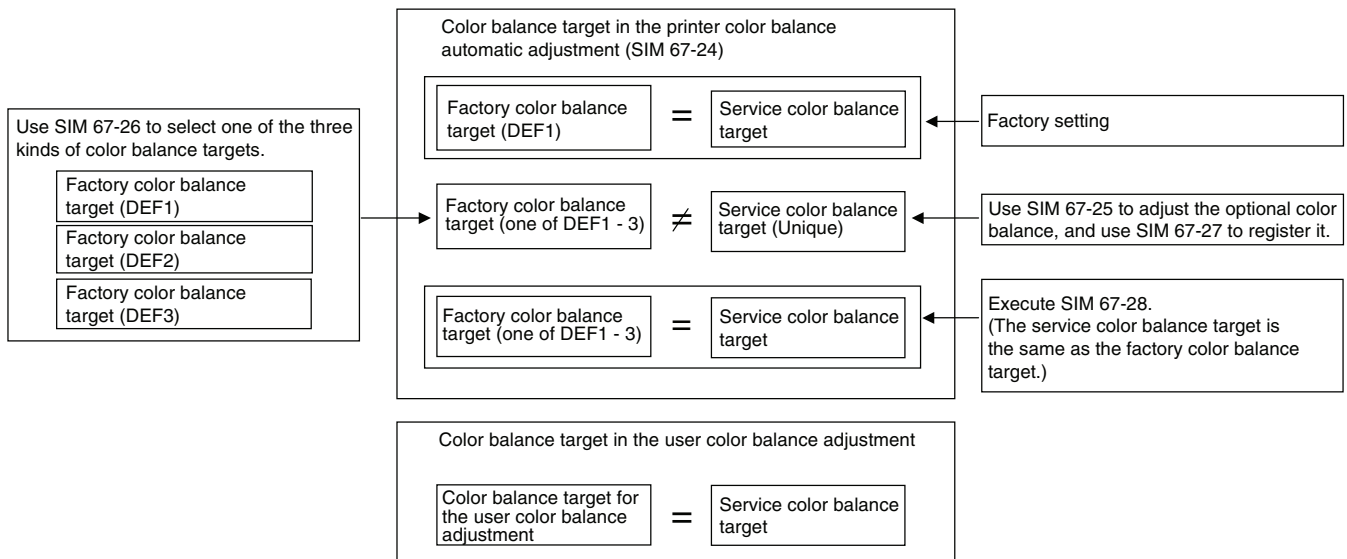

- Factory target in the printer color balance adjustment (Automatic adjustment) (SIM 46-74/67-24)  
By use of SIM 67-26, one of the following color balances can be set as the factory color balance target.  
Each of the three color balances cannot be changed. (Fixed)

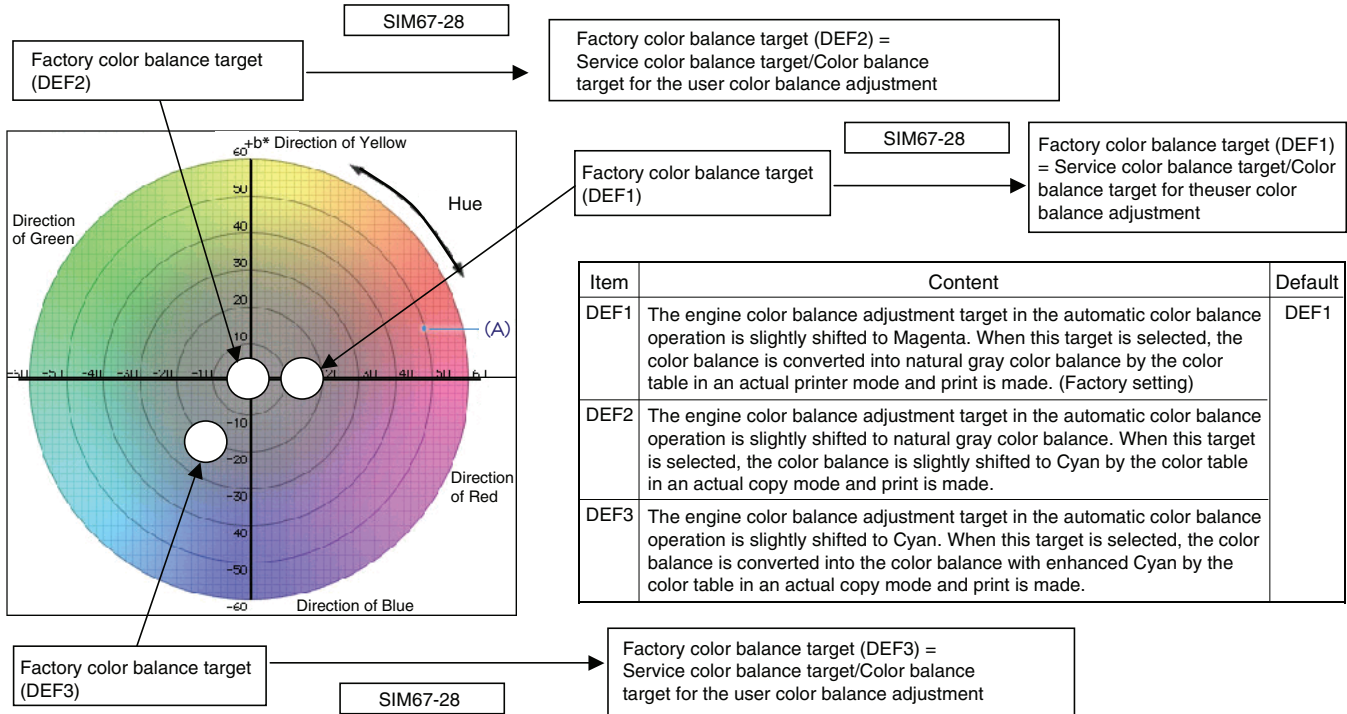

- Service color balance target in the printer color balance adjustment (Automatic adjustment) (SIM 46-74/67-24).  
For the service color balance target, an optional color balance can be adjusted with SIM 67-25 and registered with SIM 67-27. When, however, SIM 67-28 is executed, the color balance is set to the same balance as the factory color balance target set with SIM 67-26.
- Color balance target in the user color balance adjustment  
This color balance is same as the service color balance target in the printer color balance adjustment (Automatic adjustment) (SIM 46-74/67-24). When, therefore, the service color balance target is changed, this target is also changed accordingly.

(Meaning of the service color balance target gamma data and the purpose of registration)

This procedure must be executed only when the color balance is customized with SIM 67-25.

If the color balance is not customized, this procedure is not required.

After completion of the customized color balance adjustment (Manual) with SIM 67-25 according to the user's request, use SIM 67-27 to register the service color balance target data by use of the printed adjustment pattern.

**Important**

In this case, be sure to use A4 or 11" x 8.5" paper for printing the adjustment pattern by SIM 67-25.

By this procedure, the service color balance target is revised.

It is recommended to keep the printed adjustment pattern created with SIM 67-25. This adjustment pattern can be used to register the same color balance target to another machine.

It is also useful to register the service color balance target data. Do not fold it and keep it under the circumstances which protect it from discoloration and dirt.

The service color balance target data is basically registered immediately after the color balance adjustment (Manual) with SIM 67-25.

If a considerable time has passed after completion of the color balance adjustment (Manual) with SIM 67-25, the color balance of the adjustment pattern at the time of adjustment differs from the color balance of the adjustment pattern printed after a considerable time. Never use such a pattern for the adjustment.

The correctness of the service color balance target data can be judged as follows.

When result of the color balance adjustment (Auto) with selecting the service color balance target in SIM 67-24 is unsatisfactory or abnormal.

In that case, the registered service target data for the color balance adjustment (Auto) may be improper.

This may be caused when an improper or abnormal color balance adjustment pattern was used to register the service color balance target data for the color balance adjustment with SIM 67-27.

The color balance adjustment pattern used in registration was made and printed by the color balance adjustment (Manual) with SIM 67-25. This procedure may have been executed erroneously.

**a. Setting procedure**

(Setting procedure of an optional color balance (gamma) as the service color balance target)

- 1) Use SIM 67-25 (Printer color balance adjustment (manual adjustment) mode) to print two sheets of the color patch image (adjustment pattern).

**Important**

In this case, be sure to use A4 or 11" x 8.5" paper for printing the adjustment pattern by SIM 67-25.

If the color balance is shifted from the standard, an adjustment is required. If not, an adjustment is not required. When an optional color balance is requested by the user, make an adjustment.



- 2) Enter the SIM 67-27 mode.

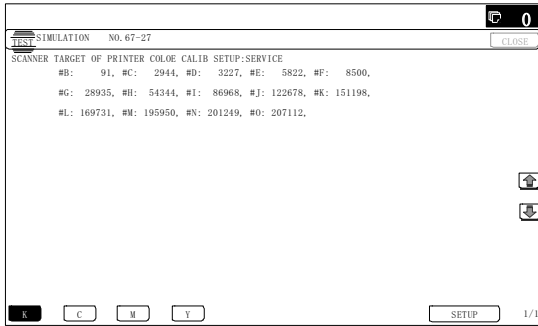

- 3) Press [SETUP] key.
- 4) Set the color patch image (adjustment pattern) correctly adjusted and printed in the printer color balance adjustment (Manual adjustment) (SIM 67-25) (ADJ 10E (2)) on the document table.  
A color patch image (adjustment pattern) printed by another machine can be used.  
Set the pattern so that the light density side is on the left side. Place 5 sheets of white paper on the color patch image (adjustment pattern).  
This procedure must not be executed when the copy color balance (manual) was adjusted with SIM 67-25 to a unique color balance requested by the user and it was registered as the service color balance target with SIM 67-27.
- 5) Press [EXECUTE] key.

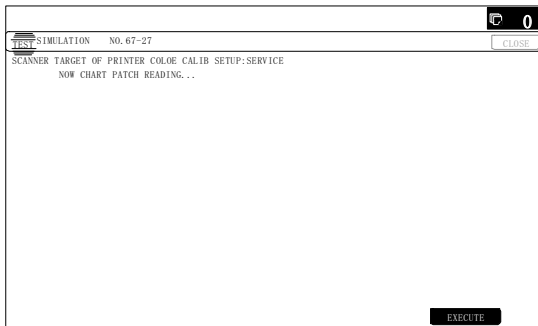

The color patch image (adjustment pattern) is read.

- 6) Press [REPEAT] key, set the second color patch image (adjustment pattern), and execute the procedure 5) again.

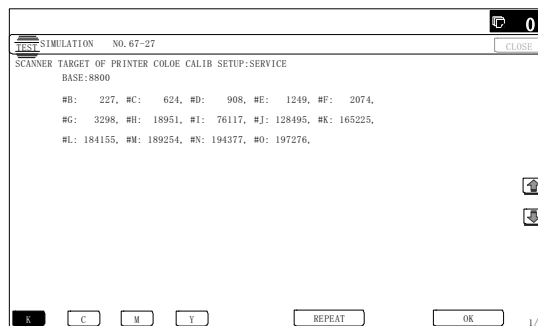

The color balance (gamma) target set level of each color (K, C, M and Y) can be checked with K/C/M/Y keys.

Check that the set level is increased in the sequence of B - Q (MAX). If there is no variation or variation is reversed, it is judged as abnormal.

In case of an abnormality, repair the problem and try again.

- 7) Press [OK] key.

The color balance (gamma) of the color patch image (adjustment pattern) used in the procedure 5) is set as the service target.

(Procedures to set the service color balance target and the color balance target for the user color balance adjustment to the same color balance as the factory color balance target)

### Important

This procedure must not be executed when the copy color balance was adjusted with SIM 67-25 to a unique color balance requested by the user and it was registered as the service color balance target with SIM 67-27.

When the factory color balance target is changed with SIM 67-26, be sure to execute this procedure.

- 1) Enter the SIM 67-28 mode.

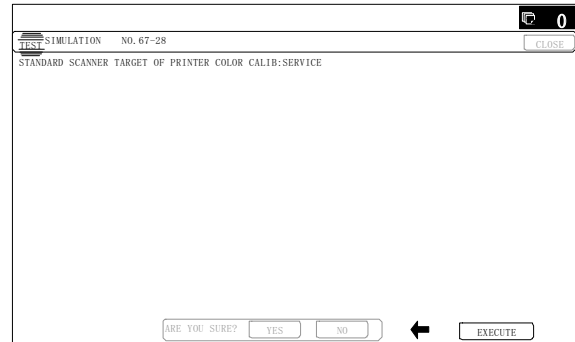

- 2) Press [EXECUTE] key.
- 3) Press [YES] key.

The service color balance target and the color balance target for the user color balance adjustment are set to the same color balance as the factory color balance target.

## 10-B Copy/Printer color balance and density adjustment (Automatic adjustment) (Basic adjustment)

This adjustment must be performed in the following cases:

- \* When a consumable part (developer, OPC drum, transfer belt) is replaced.
- \* When the CCD unit is replaced.
- \* When the scanner (reading) section is disassembled.
- \* When the scanner (reading) unit is replaced.
- \* U2 trouble has occurred.
- \* When the MFP PWB is replaced.
- \* When the EEPROM on the MFP PWB is replaced.
- \* The scanner control PWB has been replaced.
- \* The EEPROM on the scanner control PWB has been replaced.

### a. General

SIM46-74 is used to perform the automatic copy color balance and density adjustment (SIM46-24) and the automatic printer color balance and density adjustment (SIM67-24) continuously.

Since it is desirable to perform the copy color balance adjustment (automatic adjustment) before the automatic printer color balance and density adjustment, it is advisable to perform the adjustment in this mode.

This mode is also advisable to effectively perform both of the automatic copy color balance and density adjustment (SIM46-24) and the automatic printer color balance and density adjustment (SIM67-24). It saves considerable time when compared with performing each of the auto copy/printer color balance and the density adjustment individually.

The color balance adjustment (automatic adjustment) is used to adjust the copy density of each of Cyan, Magenta, Yellow, and Black automatically.

When this adjustment is executed, the color balance adjustments of all the copy/printer modes are revised.

**b. Adjustment procedures**

(Auto color balance adjustment by the serviceman)

Copy/printer color balance and density adjustment (Automatic adjustment)  
(SIM46-74) procedure flowchart

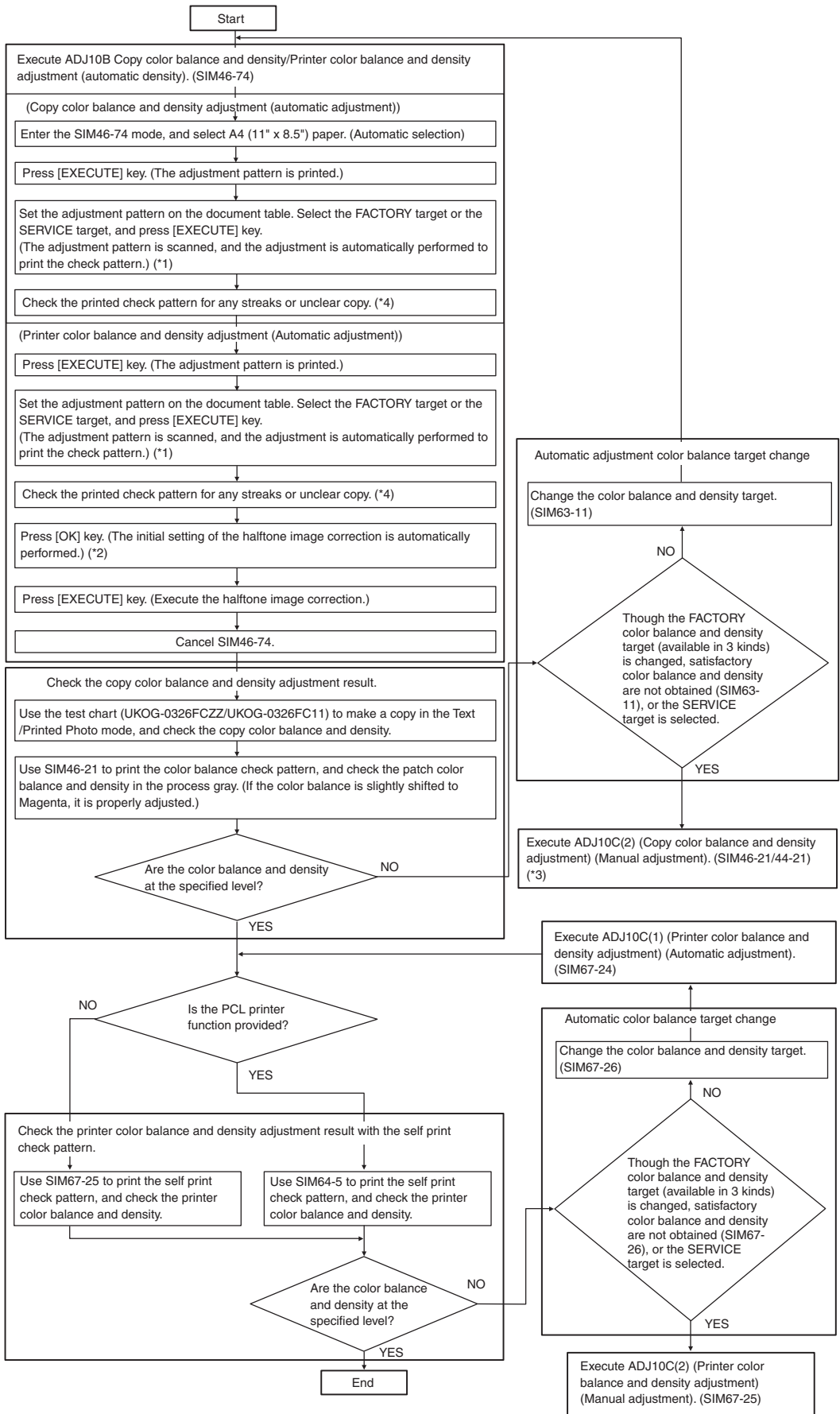

\*1:  
When the color balance and density are customized and registered as the SERVICE target, select the SERVICE target.

\*2:  
If the initial setting of the halftone image correction is not properly adjusted, satisfactory color balance and density cannot be obtained. In this case, check the print engine for any problems.

\*3:  
If satisfactory color balance and density are not obtained with ADJ10C(2) (Copy color balance and density adjustment) (Manual adjustment) (SIM46-21/44-21), check the print engine for any problems.

\*4:  
If there is any streak or unclear copy on the printed check pattern, check the print engine for any problems.

- 1) Enter the SIM46-74 mode.

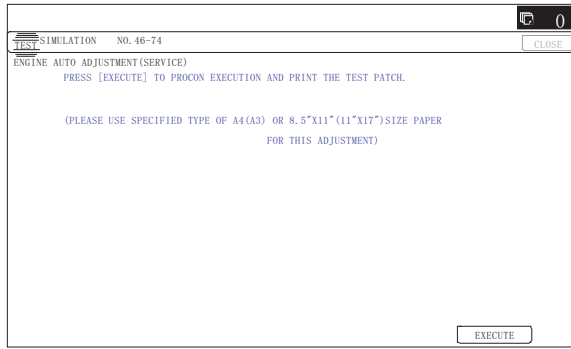

- 2) Press [EXECUTE] key.

The high density process control is performed, and the copy color patch image (adjustment pattern) is printed out. (A4/11" x 8.5" or A3/11" x 17" paper is automatically selected.)

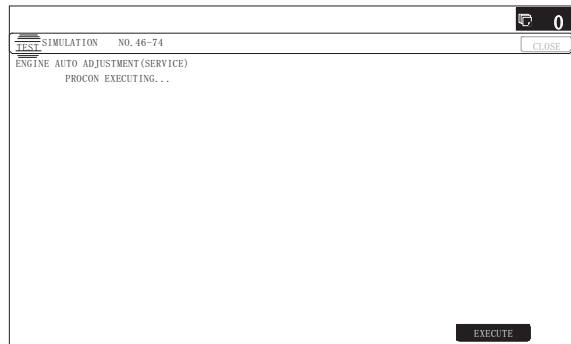

- 3) Set the color patch image (adjustment pattern) paper printed in procedure 2) on the document table.  
Set the color patch image (adjustment pattern) printed in the procedure 2) on the document table. Place the color patch image so that the fine lines are on the left side. At that time, place 5 sheets of white paper on the printed color patch image (adjustment pattern).

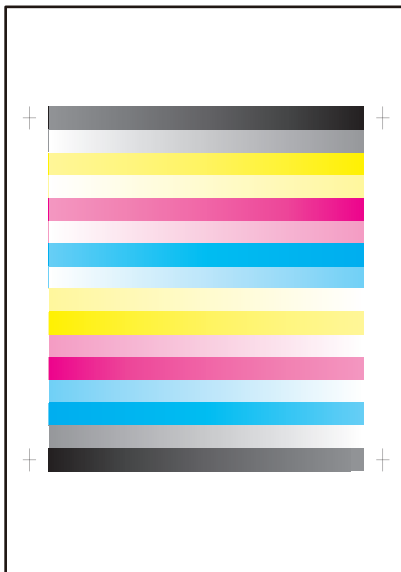

- 4) Select [FACTORY] target, and press [EXECUTE] key.

When the color balance is customized by the manual color balance adjustment (SIM 46-21) according to the user's request, and the color balance is registered with SIM63-7 as the service target, if the color balance is required to be adjusted, select the [SERVICE] target.

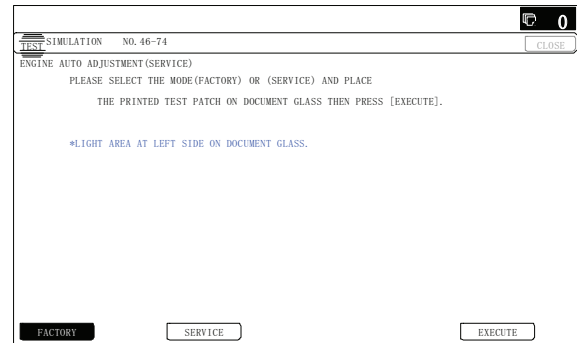

The copy color balance adjustment is automatically executed and prints the color balance check patch image.

If there is any streak or unclear print on the printed check pattern, check the print engine for any problems.

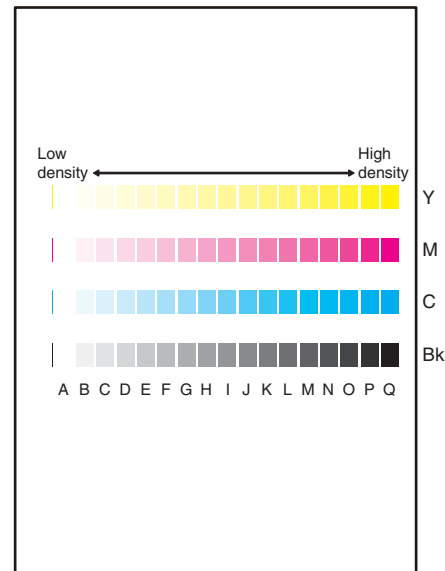

- 5) Press [EXECUTE] key.

The printer color patch image (adjustment pattern) is printed out. (A4/11" x 8.5" or A3/11" x 17" paper is automatically selected.)

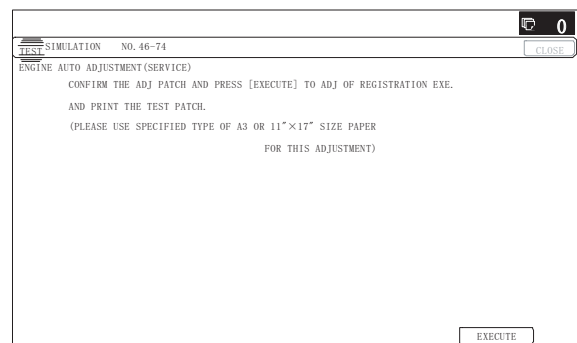

- 6) Set the color patch image (adjustment pattern) printed in the procedure 5) on the document table.

Set the color patch image (adjustment pattern) printed in the procedure 2) on the document table. Place the color patch image so that the fine lines are on the left side. At that time, place 5 sheets of white paper on the printed color patch image (adjustment pattern).

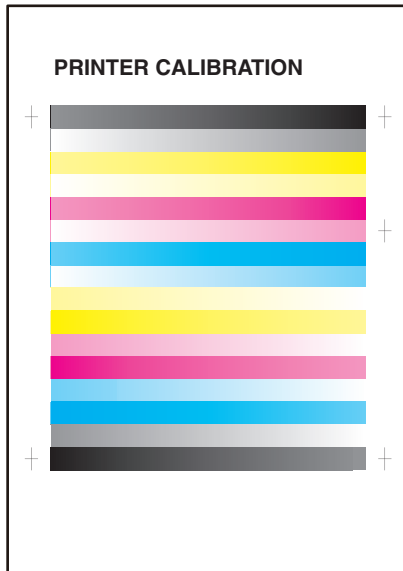

- 7) Select [FACTORY] target, and press [EXECUTE] key.

When the color balance is customized with the manual color balance adjustment (SIM 67-25) according to the user's request and the color balance is registered as the service target with SIM 67-27, if the color balance is adjusted to that color balance, select the [SERVICE] target.

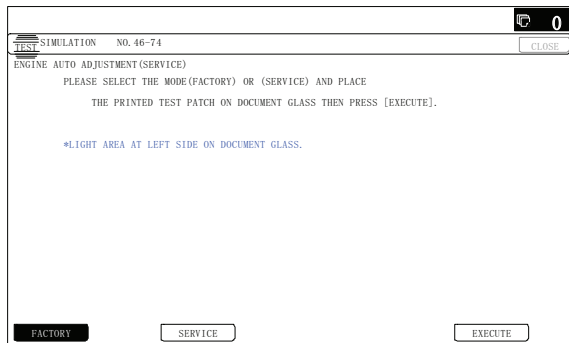

The printer color balance adjustment (step 1) is automatically performed and the color balance check patch image is printed out.

If there is any streak or unclear print on the printed check pattern, check the print engine for any problems.

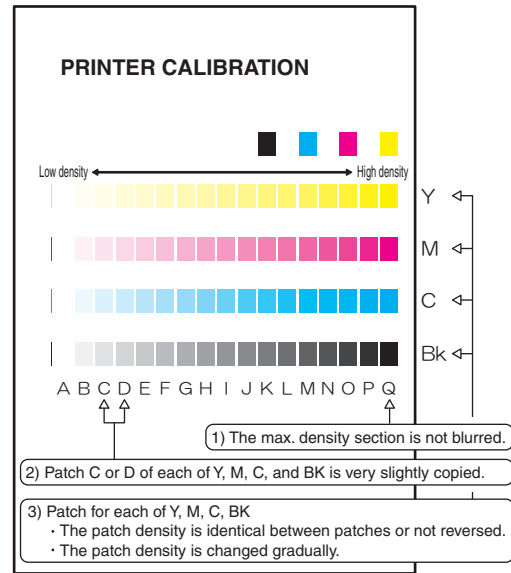

- 8) The initial setting menu of the halftone image correction is displayed. Press [OK] key.

The initial setting of the halftone image correction is performed.

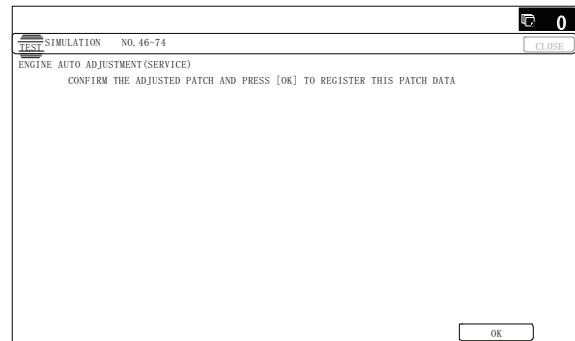

- 9) Wait until [EXECUTE] key is displayed. When it is displayed, press it.

The halftone image correction is performed.

- 10) When "COMPLETED THIS PROCEDURE" is displayed, the adjustment operation is completed.

Cancel SIM46-74.

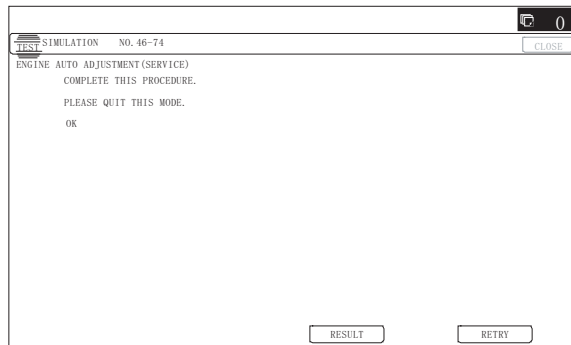

**Important**

The adjustment result becomes valid only when the both adjustments in the copy mode and in the printer mode are completed.

For example, if the copy color balance adjustment (automatic adjustment) is performed and the simulation is canceled, the adjustment result is invalid.

- 11) Check the copy color balance and density.  
(Refer to the item of the copy color balance and density check.)

When satisfactory color balance and density are not obtained from the automatic adjustment by selecting the factory target in procedure 4), change the factory color balance target with SIM 63-11 and repeat the procedures from 1).

If a satisfactory result is not obtained with the above procedure, perform the manual color balance adjustment (ADJ 10C (2)).

Also when the service target is selected in procedure 4) to execute the automatic adjustment and a satisfactory result is not obtained, perform the manual color balance adjustment (ADJ 10C (2)).

- 12) Check the printer color balance and density.  
(Refer to the item of the printer color balance and density check.)

When satisfactory color balance and density are not obtained from the automatic adjustment by selecting the factory target in procedure 7), change the factory color balance target with SIM 67-26 and repeat the procedures from 1).

If a satisfactory result on the color balance and the density is not obtained with the automatic adjustment, execute the manual adjustment (SIM 67-25) (ADJ 10E (2)).

Also when the service target is selected in procedure 7) to execute the automatic adjustment and a satisfactory result is not obtained, perform the manual color balance adjustment (ADJ 10E (2)).

If the color balance or density is not in the satisfactory level even after execution of the automatic and manual adjustments, there may be another cause.

Troubleshoot the cause, repair or perform necessary works, and repeat the adjustment from the beginning.

**10-C Copy quality adjustment (Basic adjustment)**

This adjustment must be performed in the following cases:

- \* When a consumable part (developer, OPC drum, transfer belt) is replaced.
- \* The CCD unit has been replaced.
- \* When the scanner (reading) section is disassembled.
- \* When the scanner (reading) unit is replaced.
- \* U2 trouble has occurred.
- \* When the MFP PWB is replaced.
- \* When the EEPROM on the MFP PWB is replaced.
- \* The scanner control PWB has been replaced.
- \* The EEPROM on the scanner control PWB has been replaced.

**10-C (1) Copy color balance and density adjustment (Automatic adjustment)**

**a. General**

The color balance adjustment (automatic adjustment) is used to adjust the copy density of each of Cyan, Magenta, Yellow, and Black automatically.

When this adjustment is executed, the color balance adjustments of all the copy modes are revised.

There are following two modes in the auto color balance adjustment.

- 1) Auto color balance adjustment by the serviceman (SIM 46-24 is used.)
- 2) Auto color balance adjustment by the user (The user program mode is used.) (The color balance target is the service target.)

The auto color balance adjustment by the user is provided to reduce the number of service calls.

If the copy color balance is lost for some reason, the user can use this color balance adjustment to recover the balance.

When, however, the machine has a fatal problem or when the machine condition is greatly changed, this function does not work effectively.

If the machine condition is dramatically changed, a fatal problem occurs, or the normal color targets cannot be obtained, service must recalibrate the machine to specification.

To perform the adjustment, the above difference must be fully understood.

## b. Adjustment procedure

(Auto color balance adjustment by the serviceman)

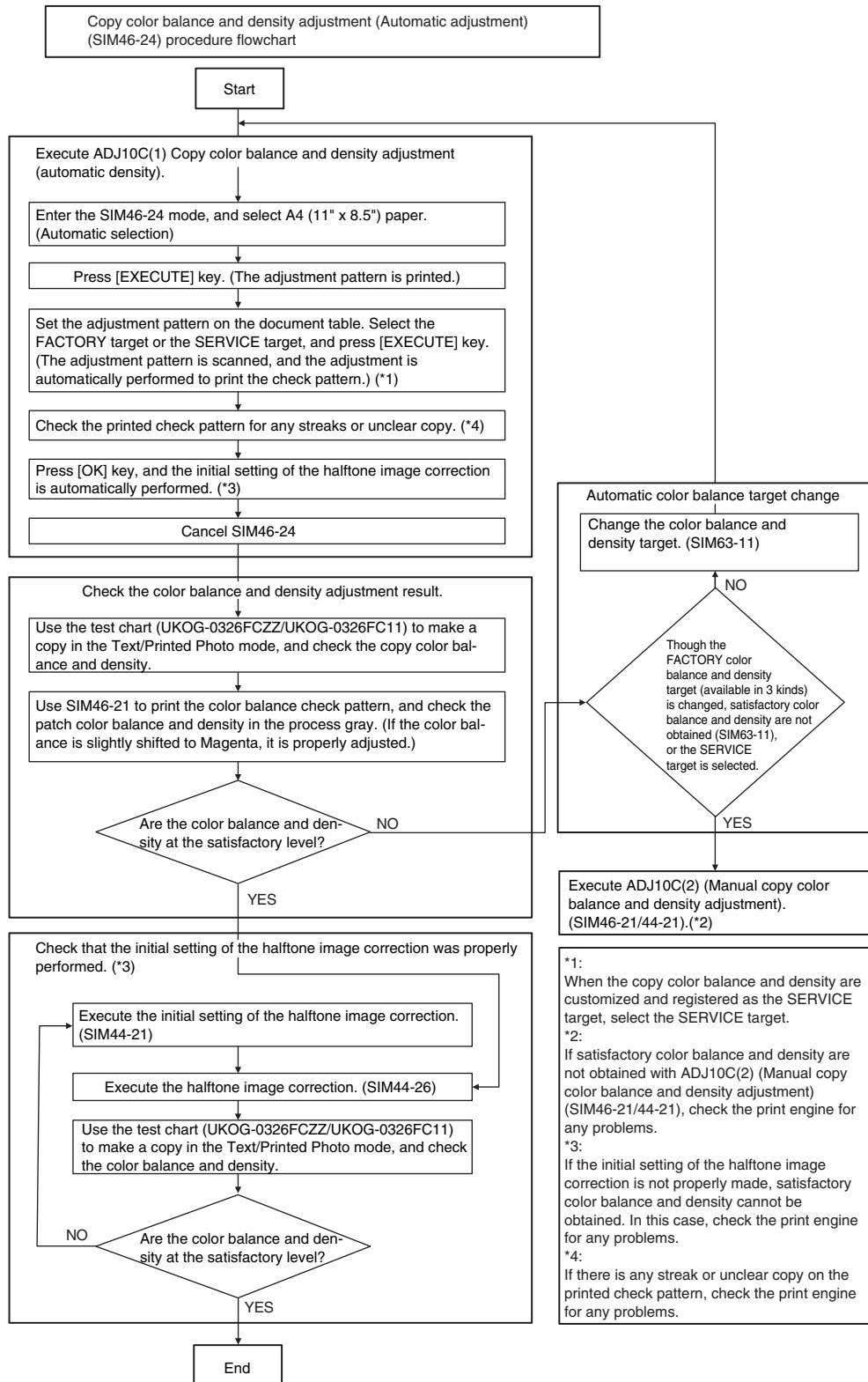

- 1) Enter the SIM 46-24 mode.

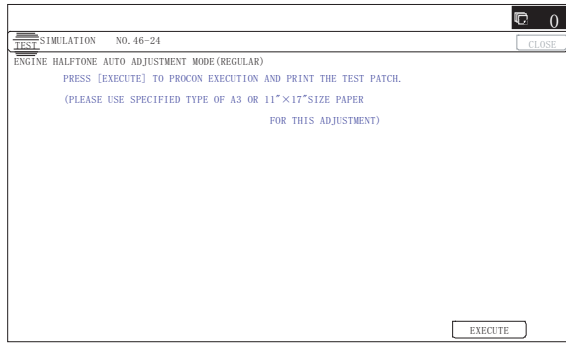

- 2) Press [EXECUTE] key. (A4/11" x 8.5" or A3/11" x 17" paper is automatically selected.)

The color patch image (adjustment pattern) is printed out.

- 3) Set the color patch image (adjustment pattern) paper printed in procedure 2) on the document table.

Place the printed color patch image (adjustment pattern) paper on the document table so that the thin lines on the paper are on the left side. Place 5 sheets of white paper on the printed color patch image (adjustment pattern) paper.

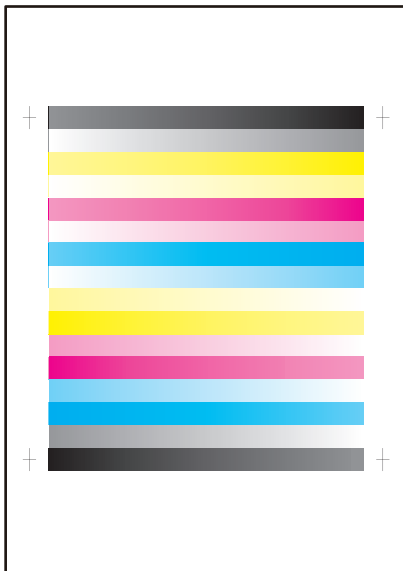

- 4) Select [FACTORY] target, and press [EXECUTE] key.

When the color balance is customized with the manual color balance adjustment (SIM 46-21) according to the user's request and the color balance is registered as the service target with SIM 63-7, if the color balance is adjusted to that color balance, select the service target.

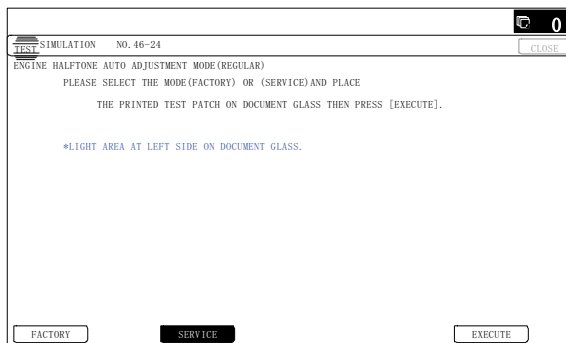

The copy color balance adjustment is automatically executed to print the color balance check patch image. Wait until the operation panel shown in procedure 5) is displayed.

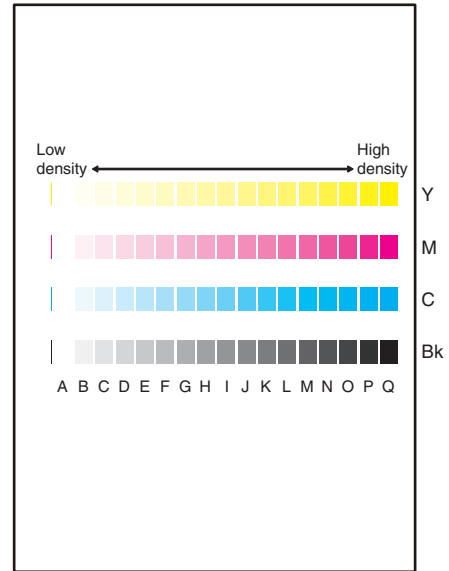

- 5) Press [OK] key on the operation panel.

According to data of this adjustment, the initial setting of the halftone image correction is performed.

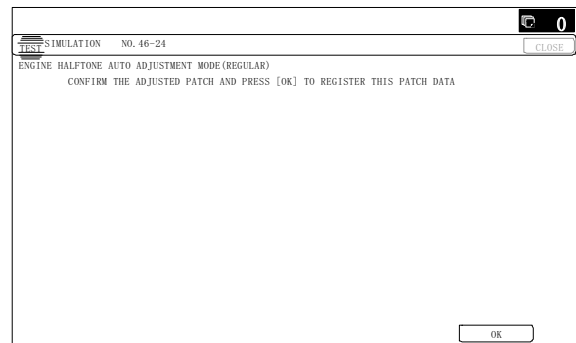

### Note

After pressing [OK] key, the initial setting of the halftone image correction is started. During the operation, "NOW REGISTERING THE NEW TARGET OF HALFTONE PROCON." is displayed. This operation takes several minutes.

After completion of the operation, "PLEASE QUIT THIS MODE" is displayed.

Do not cancel the simulation until "PLEASE QUIT THIS MODE" is displayed.

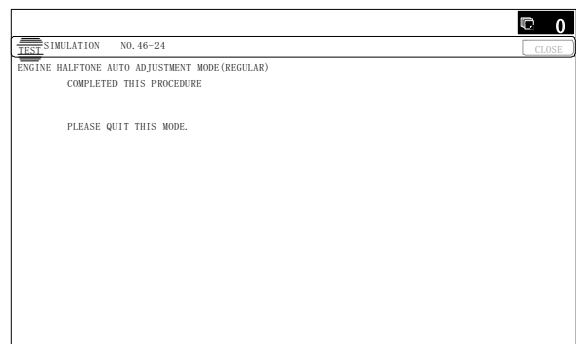

- 6) Check the color balance and density.  
(Refer to the item of the copy color balance and density check.)
- 7) Use SIM44-26 to execute the halftone image correction.  
(Forcible execution)  
Enter the SIM44-26 mode and press [EXECUTE] key.  
[EXECUTE] key is highlighted and the operation is started.

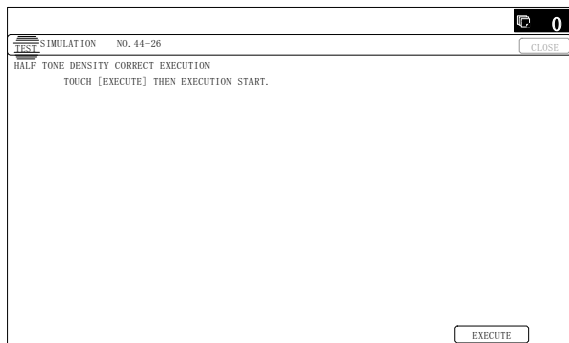

It takes several minutes to complete the operation. After completion of the operation, "COMPLETE" is displayed.

(Normal end (Auto transition))

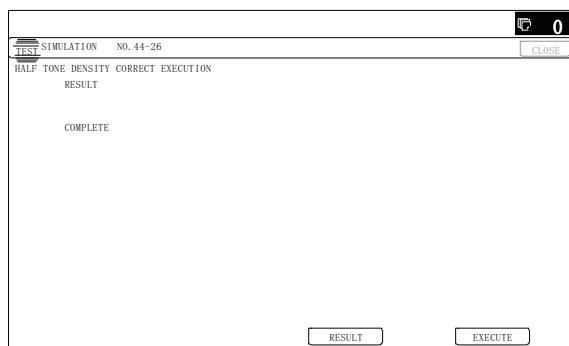

(Abnormal end (Auto transition))

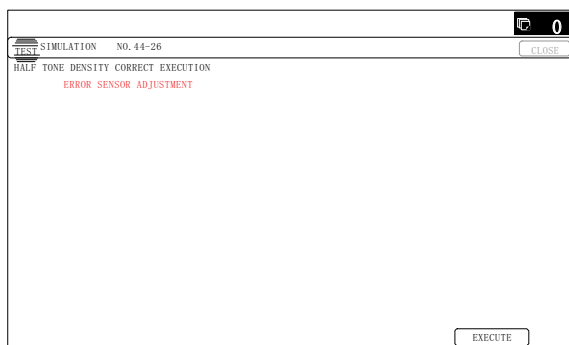

After completion of the operation, the simulation is canceled.

- 8) Use the servicing color test chart (UKOG-0326FCZZ/UKOG-0326FC11) in the Text/Photo mode (Manual) to check the copy color balance and density. (Refer to the item of the copy color balance and density check.)  
If the copy color balance and density are not satisfactory, perform the following procedures.
- 9) Execute the initial setting of the halftone image correction. (SIM 44-21)
- 10) Execute the halftone image correction. (Forcible execution) (SIM44-26)

- 11) Use the servicing color test chart (UKOG-0317FCZZ/UKOG-0317FC11) in the Text/Printed Photo mode (Manual) to check the copy color balance/density. (Refer to the item of the copy color balance and density check.)

Though the above procedures 9) - 11) are performed, the copy color balance and density are not in the specified range, there may be another cause.

Troubleshoot the cause, repair or perform necessary works, and repeat the adjustment from the beginning.

When satisfactory color balance and density are not obtained from the automatic adjustment by selecting the factory target in procedure 4), change the factory color balance target with SIM 63-11 and repeat the procedures from 1).

If a satisfactory result on the color balance and the density is not obtained with the automatic adjustment, execute the manual adjustment (SIM 46-21) (ADJ 10C (2)).

Also when the service target is selected in procedure 7) to execute the automatic adjustment and a satisfactory result is not obtained, perform the manual color balance adjustment (ADJ 10C(2)).

If the color balance or density is not in the satisfactory level even after execution of the automatic and manual adjustments, there may be another cause.

Troubleshoot the cause, repair or perform necessary works, and repeat the adjustment from the beginning.

---

## 10-C (2) Copy color balance and density adjustment (Manual adjustment)

### a. General

The color balance adjustment (Manual adjustment) is used to adjust the copy density of CMYK. This is used at the following situation. When the result of auto adjustment described above is not existing within the range of reference. When a fine adjustment is required. When there is request from the user for changing (customizing) the color balance.

This manual adjustment is executed only for the color patch which could not adjusted properly in the automatic adjustment.

If the color balance is improper, execute the automatic color balance adjustment in advance, and execute this adjustment for better efficiency.



**b. Adjustment procedure**

Copy color balance and density adjustment (Manual adjustment) procedure flowchart (SIM46-21)

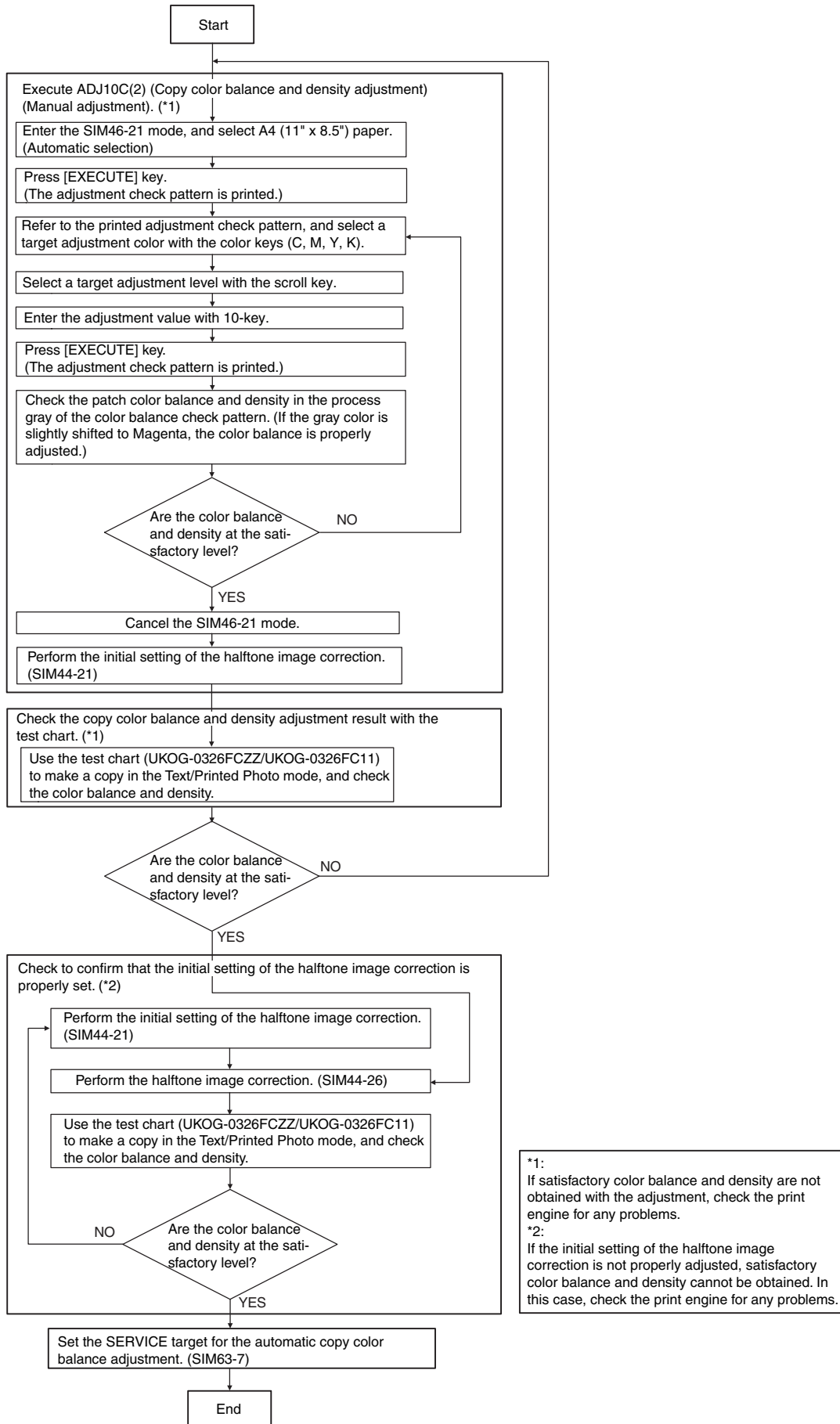

\*1:  
If satisfactory color balance and density are not obtained with the adjustment, check the print engine for any problems.

\*2:  
If the initial setting of the half-tone image correction is not properly adjusted, satisfactory color balance and density cannot be obtained. In this case, check the print engine for any problems.

- 1) Enter the SIM46-21 mode.

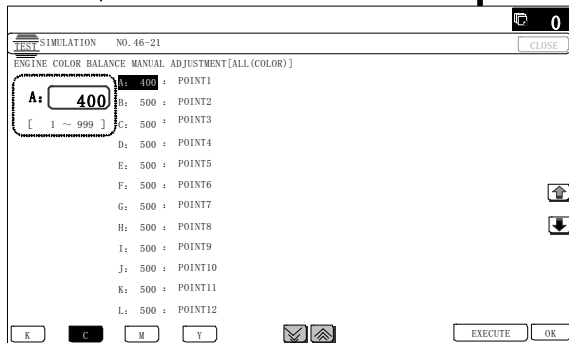
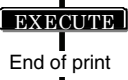
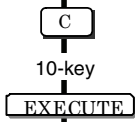
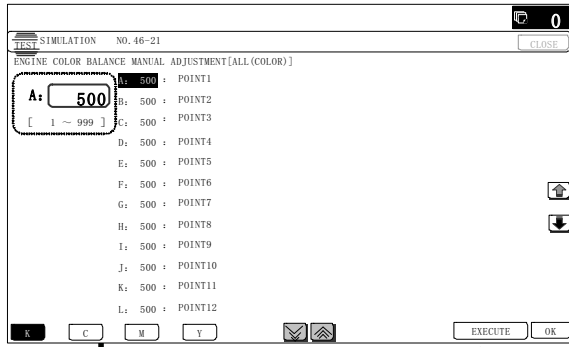

- 2) Press [EXECUTE] key. (A4/11" x 8.5" or A3/11" x 17" paper is automatically selected.)  
The color balance adjustment pattern is printed.
- 3) Check that the following specification is satisfied or the color balance is satisfactory.  
If not, execute the following procedures.

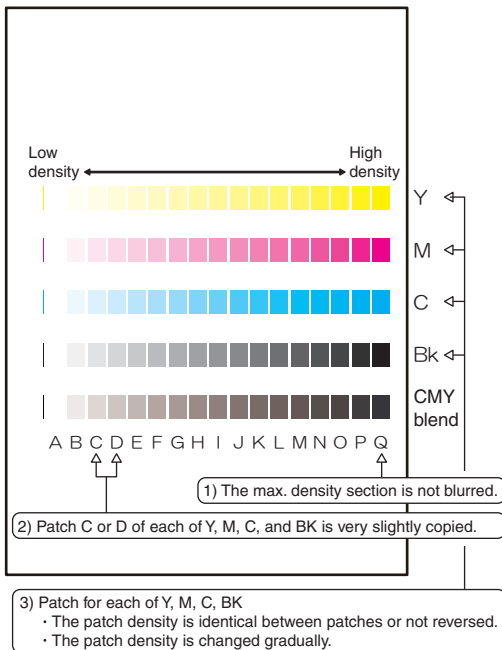

The print density must be changed gradually from the lighter level to the darker level. The density changing direction must not be reversed.

The density level of each color must be almost at the same level.

Patch B may not be copied.

Patch A must not be copied.

When, however, the color balance is adjusted according to a request from the user, there is no need to set to the standard color balance stated above.

If the color balance of each patch of the process black (CMY mixed color) is slightly shifted to Magenta, it means that the adjustment is proper. If the color balance of the adjustment pattern printed in this mode is slightly shifted to Magenta, it is converted into the natural gray color balance by the color correction table in an actual copy mode. (When the color balance target is DEF 1.)

- 4) Select the color to be adjusted with the color select key, and select the adjustment point with the scroll key.
- 5) Enter the adjustment value with 10-key and press [OK] key.

The adjustment value is set in the range of (1 - 999). When SIM 46-24 is used to adjust the automatic color balance and density, all the set values of this simulation are set to 500.

To increase the density, increase the adjustment value. To decrease the density, decrease the adjustment value.

Repeat procedures of 2) - 5) until the condition of 3) is satisfied.

When the overall density is low, or when the density is high and patch A is copied, use the arrow key to adjust all the adjustment values of A - Q (MAX) to a same level collectively.

Then, adjust each patch density individually. This is an efficient way of adjustment.

Referring to the black/gray patches, adjust so that each process (CMY) black/gray patch color balance of A - Q (MAX) approaches the black/gray patch level as far as possible.

- 6) Make a copy of the servicing color test chart (UKOG-0326FCZZ/UKOG-0326FC11) and a user's document according to necessity in the normal copy mode, the text/Printed Photo mode (Manual) to check the adjustment result.  
(Refer to the item of the copy color balance/density check.)
- 7) Execute SIM 44-21. (Execute the initial setting of the halftone image correction.)

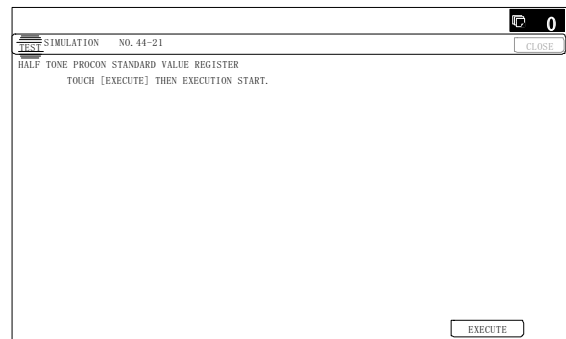

It takes several minutes to complete the operation. After completion of the operation, "COMPLETE" is displayed.

(Normal end (Auto transition))

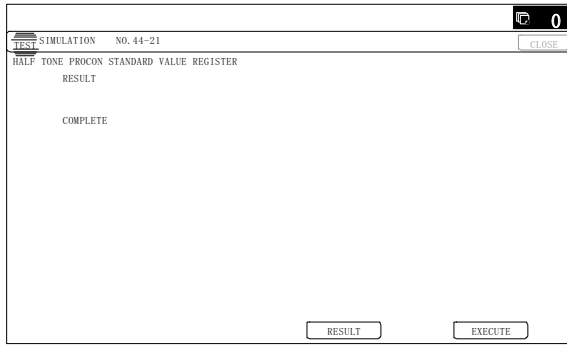

(Normal end (Auto transition))

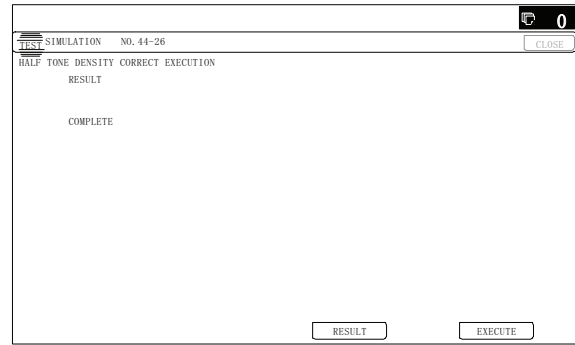

(Abnormal end (Auto transition))

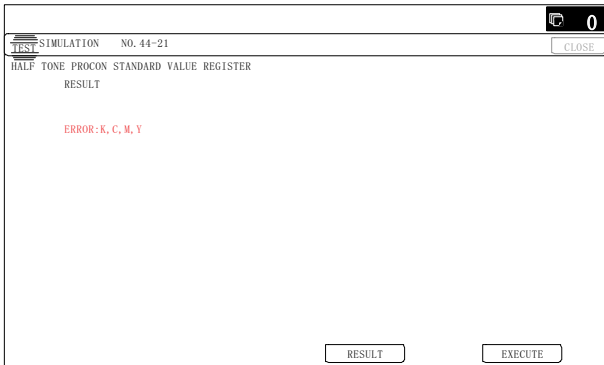

(Abnormal end (Auto transition))

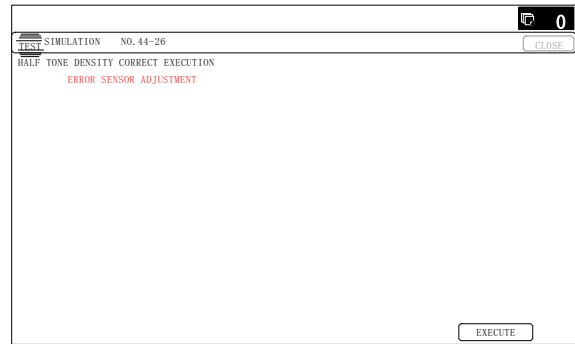

After completion of the operation, the simulation is canceled.

**Note**

This procedure is to save the copy color balance adjustment data as the reference data for the halftone correction.

Immediately after execution of ADJ 10C (2) (Color balance adjustment, Manual) with SIM 46-21, be sure to execute this procedure.

When ADJ 10C (1) (Color balance adjustment, Auto) is executed with SIM 46-24, this procedure is automatically executed.

- 8) Use SIM 44-26 to execute the halftone image correction. (Forcible execution)

Enter the SIM 44-26 mode and press [EXECUTE] key. [EXECUTE] key is highlighted and the operation is started.

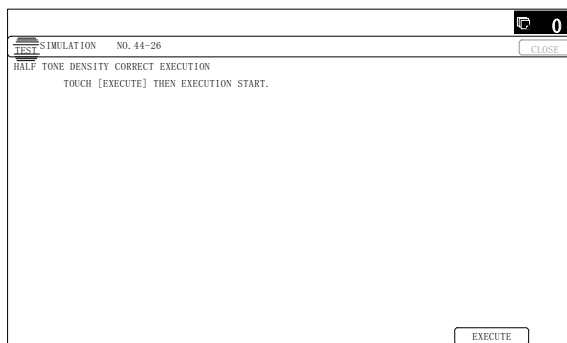

It takes several minutes to complete the operation. After completion of the operation, "COMPLETE" is displayed.

- 9) Make a copy of the servicing color test chart (UKOG-0317FCZZ/UKOG-0317FC11) and a user's document according to necessity in the Text/Printed Photo mode (Manual) and check the adjustment result again. (Refer to the item of the copy color balance/density check.)

If the copy color balance and density are not adjusted to the specified level, there may be another cause.

Troubleshoot the cause, and repair or perform proper treatments, and try all the procedures of the print image adjustment from the beginning.

**Note**

If the color balance is customized, use SIM 63-7 to register the color balance as the service target.

If the color balance is not customized, this procedure is not required.

If the customized color balance is registered as the service target, the automatic color balance adjustment can be made in the next color balance adjustment.

## 10-D Copy / Image send / FAX image quality adjustment (Individual adjustment)

### a. General

This adjustment is used to execute the fine adjustment in each mode only when a satisfactory image quality is not obtained by the basic adjustments ADJ 10B and ADJ 10C or there is a request from the user. Normally there is no need to execute this adjustment.

In this adjustment, the adjustment result may be applied to the image send mode and the FAX mode as well as the copy mode.

This must be well understood for execution of the adjustment.

		Copy MODE				IMAGE SEND(SCAN) MODE				FAX	Printer
		Color mode		Monochrome mode		Color mode		Monochrome mode			
		Auto	Manual	Auto	Manual	Auto	Manual	Auto	Manual		
46-01	Color copy density adjustment (for each color copy mode) (separately for the low-density area and the high-density area) (No need to adjust normally)	○	○	-	-	-	-	-	-	-	-
46-02	Monochrome copy density adjustment (for each monochrome copy mode) (separately for the low-density area and the high-density area) (No need to adjust normally)	-	-	○	○	-	-	-	-	-	-
46-04	Color image send mode image density adjustment (for each mode) (No need to adjust normally)	-	-	-	-	○	○	-	-	-	-
46-05	Monochrome image send mode image density adjustment (for each mode) (No need to adjust normally)	-	-	-	-	-	-	○	○	-	-
46-08	Image send mode RGB color balance adjustment (separately for the low-density area and the high-density area) (No need to adjust normally)	-	-	-	-	○	○	-	-	-	-
46-09	RSPF mode (Copy/Scan/FAX) density adjustment (No need to adjust normally)	○	○	○	○	○	○	○	○	○	-
46-10	Color copy color balance, gamma adjustment (for each color copy mode) (No need to adjust normally)	○	○	-	-	-	-	-	-	-	-
46-16	Monochrome copy density, gamma adjustment (for each monochrome copy mode) (No need to adjust normally)	-	-	○	○	-	-	-	-	-	-
46-19	Automatic monochrome (Copy/Scan/FAX) mode document density scanning operation (exposure operation) conditions setting (Normally no need to set)	-	-	○	-	-	-	○	-	○	-
46-21	Copy color balance and density adjustment (Manual adjustment)	○	○	○	○	-	-	-	-	-	-
46-23	Copy high density image density reproduction setting (Normally unnecessary to the setting change)	○	○	○	○	-	-	-	-	-	-
46-24	Copy color balance and density adjustment (Automatic adjustment)	○	○	○	○	-	-	-	-	-	-
46-25	Copy color balance adjustment (Single color copy mode) (No need to adjust normally)	-	○	-	-	-	-	-	-	-	-
46-26	Single color copy mode color balance default setting	-	○	-	-	-	-	-	-	-	-
46-27	Color copy, text, line image reproduction adjustment (edge gamma, density adjustment) (Text, Map mode) (No need to adjust normally)	○	○	-	-	-	-	-	-	-	-
46-30	Copy mode sub scanning direction resolution setting	○	○	-	-	-	-	-	-	-	-
46-32	Document low density image density reproduction adjustment in the automatic monochrome (Copy/Scan/FAX) mode (No need to adjust normally) (Background density adjustment in the scanning section)	-	-	○	-	-	-	○	-	○	-
46-36	2-color (red, black) copy mode fine color adjustment (No need to adjust normally)	-	○	-	-	-	-	-	-	-	-
46-37	Monochrome (Copy/Scan/FAX) mode color document reproduction adjustment (No need to adjust normally)	-	-	○	○	-	-	○	○	○	○ (*3)(*5)
46-38	Color copy mode dark area gradation (black component quantity) adjustment (No need to adjust normally)	○	○	-	-	-	-	-	-	-	-
46-39	FAX send image sharpness adjustment	-	-	-	-	-	-	-	-	○	-
46-40	FAX send image density adjustment (Collective adjustment of all the modes)	-	-	-	-	-	-	-	-	○	-

		Copy MODE				IMAGE SEND(SCAN) MODE				FAX		Printer	
		Color mode		Monochrome mode		Color mode		Monochrome mode					
		Auto	Manual	Auto	Manual	Auto	Manual	Auto	Manual				
46-41	FAX send image density adjustment (Normal text mode)	-	-	-	-	-	-	-	-	-	○	-	
46-42	FAX send image density adjustment (Fine text mode)	-	-	-	-	-	-	-	-	-	○	-	
46-43	FAX send image density adjustment (Super fine mode)	-	-	-	-	-	-	-	-	-	○	-	
46-44	FAX send image density adjustment (Ultra fine mode)	-	-	-	-	-	-	-	-	-	○	-	
46-45	FAX send image density adjustment (600dpi mode)	-	-	-	-	-	-	-	-	-	○	-	
46-46	FAX send image density adjustment (RGB_RIP)	-	-	-	-	-	-	-	-	-	○ (*2)(*5)	-	
46-47	Copy image, image send image, FAX send image (JPEG) compression ratio setting (Normally unnecessary to the setting change)	○	○	○	○	○	○	○	○	○	○ (*3)(*5)	○ (*3)(*5)	
46-51	Gamma manual adjustment for the copy mode heavy paper and the image process mode (dither) (No need to adjust normally)	○	○	○	○	-	-	-	-	-	-	-	
46-52	Gamma default setting for the copy mode heavy paper and the image process mode (dither)	○	○	○	○	-	-	-	-	-	-	○ (*4)(*5)	
46-54	Copy gamma, color balance adjustment for each dither (Automatic adjustment) (No need to adjust normally)	○	○	○	○	-	-	-	-	-	-	○ (*4)(*5)	
46-55	Dropout color setting	-	-	-	-	-	-	-	○	-	-	-	
46-58	Pseudo resolution UP function setting	○	○	○	○	-	-	-	-	-	-	-	
46-59	Pseudo resolution UP function adjustment	○	○	○	○	-	-	-	-	-	-	○	
46-60	Color (Copy/Scan) mode sharpness adjustment (No need to adjust normally)	○	○ (1 copy)	-	-	○	-	-	-	-	-	○	
46-61	Area separation recognition level adjustment (No need to adjust normally)	○	○ (*1)	○	○ (*1)	○	○ (*1)	○	○ (*1)	-	-	-	
46-62	ACS, area separation, background image process, automatic exposure mode operation conditions setting (Normally unnecessary to the setting change)	○	○	○	○	○	○	○	○	-	-	-	
46-63	Copy/Scan low density image density adjustment (for each mode) (No need to adjust normally)	○	○	○	○	○	○	○	○	-	-	-	
46-65	Color correction table setting	○	○	-	-	-	-	-	-	-	-	○	
46-66	Watermark adjustment	○	○	○	○	-	-	-	-	-	-	-	
46-74	Printer/Copy color balance and density adjustment (Automatic adjustment) (Basic adjustment)	○	○	○	○	-	-	-	-	-	-	○	
46-90	High-compression PDF image process operation setting (Normally unnecessary to the setting change)	-	-	-	-	○	○	-	-	-	-	-	
46-91	Black text emphasis fine adjustment	-	-	-	-	○	○	-	-	-	-	-	

\*1: Text Printed Photo / Copy document, Text Printed Photo only

\*2: Printer RGB save → FAX resend only

\*3: Printer RGB save only

\*4: Only the watermark is related.

\*5: 26cpm/36cpm/31cpm(A) machine only

**10-D (1)**

**Color copy density adjustment (for each color copy mode) (separately for the low-density area and the high-density area) (No need to adjust normally)**

The density is adjusted in each copy mode individually.

This adjustment must be performed in the following cases:

- \* When there is necessity to change the copy density of the low density and high density part at each copy density individually.
- \* When there is necessity to change the density gradient of the copy by each the copy mode individually.
- \* When there is necessity to change all copy density by each the copy mode individually.
- \* When there is request from the user.

1) Enter the SIM 46-1 mode.

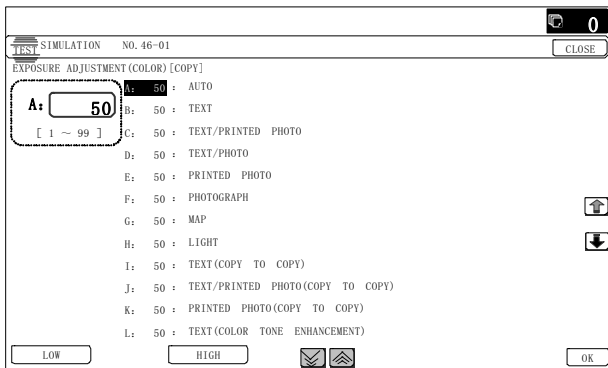

10-key

OK

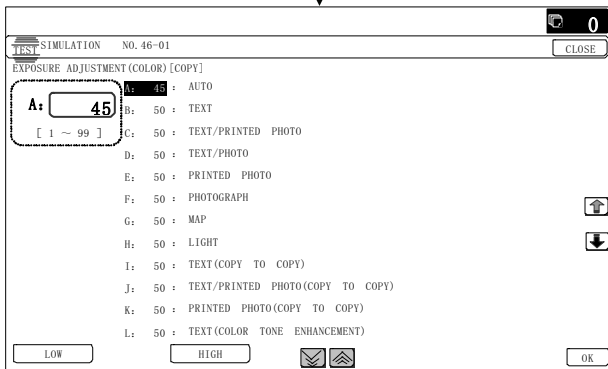

2) Select the copy mode to be adjusted with the scroll key.

Display/Item	Content	Setting range		Default
		Setting	range	
A AUTO	Auto	LOW	1 - 99	50
		HIGH	1 - 99	50
B TEXT	Text	LOW	1 - 99	50
		HIGH	1 - 99	50
C TEXT/PRINTED PHOTO	Text/Printed Photo	LOW	1 - 99	50
		HIGH	1 - 99	50
D TEXT/PHOTO	Text/Photograph	LOW	1 - 99	50
		HIGH	1 - 99	50
E PRINTED PHOTO	Printed Photo	LOW	1 - 99	50
		HIGH	1 - 99	50
F PHOTOGRAPH	Photograph	LOW	1 - 99	50
		HIGH	1 - 99	50
G MAP	Map	LOW	1 - 99	50
		HIGH	1 - 99	50
H LIGHT	Light document	LOW	1 - 99	50
		HIGH	1 - 99	50
I TEXT (COPY TO COPY)	Text (Copy document)	LOW	1 - 99	50
		HIGH	1 - 99	50
J TEXT/PRINTED PHOTO (COPY TO COPY)	Text/Printed Photo (Copy document)	LOW	1 - 99	50
		HIGH	1 - 99	50
K PRINTED PHOTO (COPY TO COPY)	Printed Photo (Copy document)	LOW	1 - 99	50
		HIGH	1 - 99	50
L TEXT (COLOR TONE ENHANCEMENT)	Text (Color tone enhancement)	LOW	1 - 99	50
		HIGH	1 - 99	50
M TEXT/PRINTED PHOTO (COLOR TONE ENHANCEMENT)	Text/Printed Photo (Color tone enhancement)	LOW	1 - 99	50
		HIGH	1 - 99	50
N TEXT/PHOTO (COLOR TONE ENHANCEMENT)	Text/Photograph (Color tone enhancement)	LOW	1 - 99	50
		HIGH	1 - 99	50
O PRINTED PHOTO (COLOR TONE ENHANCEMENT)	Printed Photo (Color tone enhancement)	LOW	1 - 99	50
		HIGH	1 - 99	50
P PHOTOGRAPH (COLOR TONE ENHANCEMENT)	Photograph (Color tone enhancement)	LOW	1 - 99	50
		HIGH	1 - 99	50
Q MAP (COLOR TONE ENHANCEMENT)	Map (Color tone enhancement)	LOW	1 - 99	50
		HIGH	1 - 99	50
R SINGLE COLOR	Single color	LOW	1 - 99	50
		HIGH	1 - 99	50
S SINGLE COLOR (COPY TO COPY)	Single color (Copy document)	LOW	1 - 99	50
		HIGH	1 - 99	50
T TWO COLOR	Two-color (Red/Black) copy	LOW	1 - 99	50
		HIGH	1 - 99	50
U TWO COLOR (COPY TO COPY)	Two-color (Red/Black) copy (Copy document)	LOW	1 - 99	50
		HIGH	1 - 99	50

- 3) Enter the adjustment value with 10-key and press [OK] key.  
When adjusting the copy density on the low density part, select "LOW" mode and change the adjustment value. When adjusting the copy density on the high density part, select "HIGH" mode and change the adjustment value.  
When the adjustment value is increased, the copy density is increased. When the adjustment value is decreased, the copy density is decreased.
- 4) Make a copy and check the adjustment result.  
Switch the adjustment simulation mode and the normal copy mode alternately, and adjust and check the adjustment result.  
Repeat switching the adjustment simulation mode and the normal copy mode and changing the adjustment value and checking the copy until a satisfactory result is obtained.

**10-D (2)**  
**Monochrome copy density adjustment**  
**(for each monochrome copy mode)**  
**(separately for the low-density area and the**  
**high-density area)**  
**(No need to adjust normally)**

The density is adjusted in each copy mode individually.

This adjustment must be performed in the following cases:

- \* When there is necessity to change the copy density of the low density and high density part at each copy density individually.
- \* When there is necessity to change the density gradient of the copy by each the copy mode individually.
- \* When there is necessity to change all copy density by each the copy mode individually.
- \* When there is request from the user.

- 1) Enter the SIM 46-2 mode.

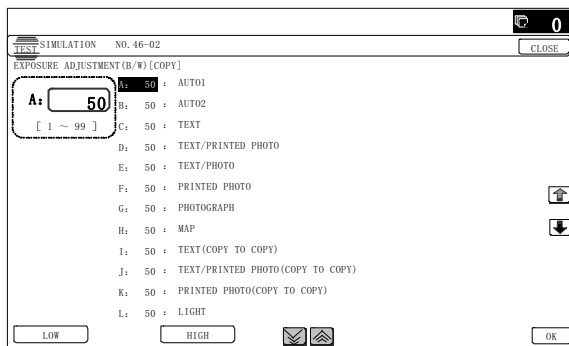

10-key

OK

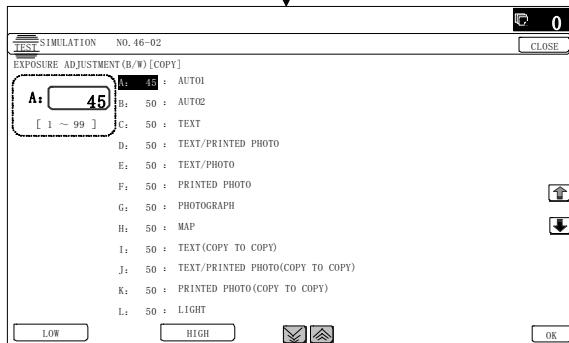

- 2) Select the copy mode to be adjusted with the scroll key.

Display/Item	Content	Setting range	Default	
A	AUTO1	Auto 1	LOW 1 - 99	50
			HIGH 1 - 99	50
B	AUTO2	Auto 2	LOW 1 - 99	50
			HIGH 1 - 99	50
C	TEXT	Text	LOW 1 - 99	50
			HIGH 1 - 99	50
D	TEXT/PRINTED PHOTO	Text/Printed Photo	LOW 1 - 99	50
			HIGH 1 - 99	50
E	TEXT/PHOTO	Text/Photograph	LOW 1 - 99	50
			HIGH 1 - 99	50
F	PRINTED PHOTO	Printed Photo	LOW 1 - 99	50
			HIGH 1 - 99	50
G	PHOTOGRAPH	Photograph	LOW 1 - 99	50
			HIGH 1 - 99	50
H	MAP	Map	LOW 1 - 99	50
			HIGH 1 - 99	50
I	TEXT (COPY TO COPY)	Text (Copy document)	LOW 1 - 99	50
			HIGH 1 - 99	50
J	TEXT/PRINTED PHOTO (COPY TO COPY)	Text/Printed Photo (Copy document)	LOW 1 - 99	50
			HIGH 1 - 99	50
K	PRINTED PHOTO (COPY TO COPY)	Printed Photo (Copy document)	LOW 1 - 99	50
			HIGH 1 - 99	50
L	LIGHT	Light document	LOW 1 - 99	50
			HIGH 1 - 99	50

- 3) Enter the adjustment value with 10-key and press [OK] key.  
When adjusting the copy density on the low density part, select "LOW" mode and change the adjustment value. When adjusting the copy density on the high density part, select "HIGH" mode and change the adjustment value.  
When the adjustment value is increased, the copy density is increased. When the adjustment value is decreased, the copy density is decreased.
- 4) Make a copy and check the adjustment result.  
Switch the adjustment simulation mode and the normal copy mode alternately, and adjust and check the adjustment result.  
Repeat switching the adjustment simulation mode and the normal copy mode and changing the adjustment value and checking the copy until a satisfactory result is obtained.

**10-D (3)**  
**Color copy color balance, gamma**  
**adjustment (for each color copy mode)**  
**(No need to adjust normally)**

This adjustment is used to execute the color balance adjustment for each density level in each color copy mode.

This adjustment must be performed in the following cases:

- \* When there is necessity to change the color balance and gamma by each the copy mode individually.
- \* When there is request from the user.

1) Enter the SIM 46-10 mode.

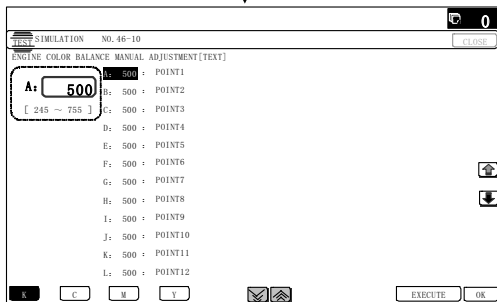
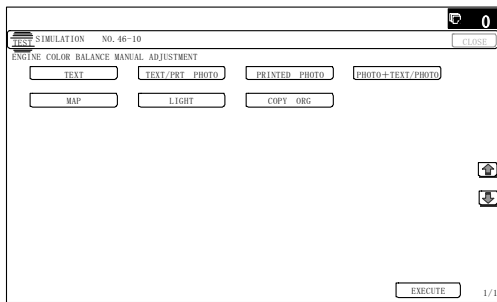

C  
10-key  
OK

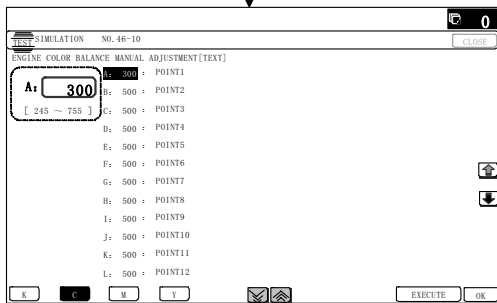

EXECUTE

EXECUTE  
or end of print

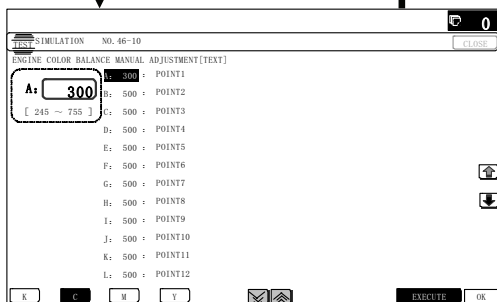

[SYSTEM SETTINGS] key

- 2) Select the copy mode to be adjusted with the mode key.
- 3) Select a color to change the adjustment value with the color key.
- 4) Select the density level (point) to be adjusted with the scroll key.

Item/Display	Density level (Point)	Adjustment value range	Default	
A	POINT1	Point 1	1 - 999	500
B	POINT2	Point 2	1 - 999	500
C	POINT3	Point 3	1 - 999	500
D	POINT4	Point 4	1 - 999	500
E	POINT5	Point 5	1 - 999	500
F	POINT6	Point 6	1 - 999	500
G	POINT7	Point 7	1 - 999	500
H	POINT8	Point 8	1 - 999	500
I	POINT9	Point 9	1 - 999	500
J	POINT10	Point 10	1 - 999	500
K	POINT11	Point 11	1 - 999	500
L	POINT12	Point 12	1 - 999	500
M	POINT13	Point 13	1 - 999	500
N	POINT14	Point 14	1 - 999	500
O	POINT15	Point 15	1 - 999	500
P	POINT16	Point 16	1 - 999	500
Q	POINT17	Point 17	1 - 999	500

- 5) Enter the adjustment value with 10-key and press [OK] key.  
When the adjustment value is increased, the density is increased. When the adjustment value is decreased, the density is decreased.  
When the arrow key is pressed, the color densities selected with the color keys are collectively adjusted.  
That is, all the density levels (points) from the low density point to the high density point can be adjusted collectively.  
When [EXECUTE] key is pressed, the adjustment pattern is printed out.  
This adjustment pattern can be used to check the color balance and the density for each density level (point).
- 6) Make a copy and check the adjustment result.  
Switch the adjustment simulation mode and the normal copy mode alternately, and adjust and check the adjustment result.  
Repeat switching the adjustment simulation mode and the normal copy mode and changing the adjustment value and checking the copy until a satisfactory result is obtained.

### 10-D (4) Monochrome copy density, gamma adjustment (for each monochrome copy mode) (No need to adjust normally)

This adjustment is used to execute the density adjustment for each density level in each monochrome copy mode.

This adjustment must be performed in the following cases:

- \* When it is required to change the gamma in each copy mode.
- \* When there is request from the user.



- 1) Enter the SIM 46-16 mode.

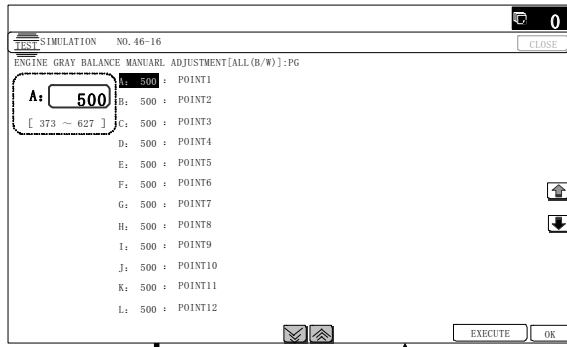

10-key  
EXECUTE

EXECUTE  
or end of print

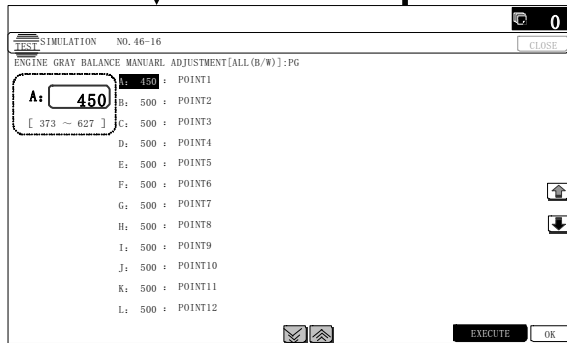

- 2) Select the density level (point) to be adjusted with the scroll key.

Item/Display	Density level (Point)	Adjustment value range	Default	
A	POINT1	Point 1	1 - 999	500
B	POINT2	Point 2	1 - 999	500
C	POINT3	Point 3	1 - 999	500
D	POINT4	Point 4	1 - 999	500
E	POINT5	Point 5	1 - 999	500
F	POINT6	Point 6	1 - 999	500
G	POINT7	Point 7	1 - 999	500
H	POINT8	Point 8	1 - 999	500
I	POINT9	Point 9	1 - 999	500
J	POINT10	Point 10	1 - 999	500
K	POINT11	Point 11	1 - 999	500
L	POINT12	Point 12	1 - 999	500
M	POINT13	Point 13	1 - 999	500
N	POINT14	Point 14	1 - 999	500
O	POINT15	Point 15	1 - 999	500
P	POINT16	Point 16	1 - 999	500
Q	POINT17	Point 17	1 - 999	500

- 3) Enter the adjustment value with 10-key and press [OK] key.  
When the adjustment value is increased, the density is increased. When the adjustment value is decreased, the density is decreased.  
When the arrow key is pressed, the densities are collectively adjusted.  
That is, all the density levels (points) from the low density point to the high density point can be adjusted collectively.  
When [EXECUTE] key is pressed, the adjustment pattern is printed out.  
The density at each density level (point) can be checked by referring to this printed adjustment pattern. However, it is more practical to make a copy and check it.  
This adjustment pattern can be used to check the color balance and the density for each density level (point).

- 4) Make a copy and check the adjustment result.  
Switch the adjustment simulation mode and the normal copy mode alternately, and adjust and check the adjustment result.  
Repeat switching the adjustment simulation mode and the normal copy mode and changing the adjustment value and checking the copy until a satisfactory result is obtained.

### 10-D (5) Automatic monochrome (Copy/Scan/FAX) mode document density scanning operation (exposure operation) conditions setting (Normally no need to set)

Use for setting the condition of read operation (Exposure) for document density in monochrome auto copy mode.

When a copy with correct density is not obtained by type of document, change the setting.

This setting is required in the following cases.

- \* When a proper density copy is not obtained in the monochrome automatic copy mode.
- \* When a document with images near its lead edge is copied.
- \* When a document with colored background is copied.

- 1) Enter the SIM 46-19 mode.

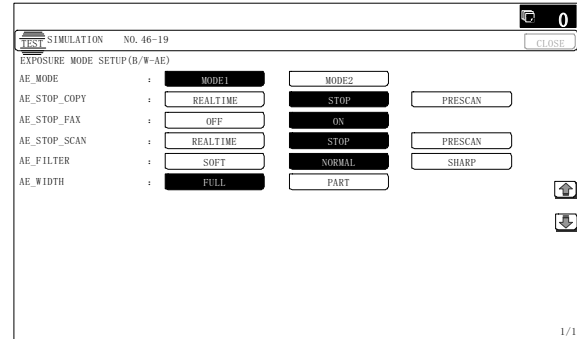

- 2) Set REALTIME, STOP or PRE-SCAN to adjustment item AE STOP COPY. For contents of each setting item, refer to below. Change the setting value of "AE WIDTH" item to "FULL" or "PART", in some cases.

Display/Item	Content	Set value	Default
AE_MODE	Auto exposure mode	MODE1, MODE2	MODE1
AE_STOP_COPY	Auto B/W exposure Stop (for copy)	REALTIME/ STOP/PRESCAN	STOP
AE_STOP_FAX	Auto B/W exposure Stop (for FAX)	ON/OFF	ON
AE_STOP_SCAN	Auto B/W exposure Stop (for scanner)	REALTIME/ STOP/PRESCAN	STOP
AE_FILTER	Auto exposure filter setting	SOFT NORMAL SHARP	NORMAL
AE_WIDTH	AE exposure width	FULL PART	FULL

#### Note

MODE1: High gamma (Improves the image contrast)

MODE2: Normal gamma

STOP:

Reads the density of 3 - 7 mm area from leading edge of document, decides the output image density according to the density of that part. (The output image density is constant at whole area.)

REALTIME:

Reads the density of width of the document one by one, decides the output image density according to the density of each part of the document. (The output image density may be not constant at whole area.)

**PRESCAN:**

Once the densities on the document surface are scanned, the output image density is determined according to the average of the scanned densities. (The output image density is even for all the surface.)

**AE WIDTH FULL:**

Document density reading area in monochrome auto mode is 3 - 7 mm (leading edge of document) x Document width. No relationship to PRESCAN MODE

**AE WIDTH PART:**

Document density reading area in monochrome auto mode is 3 - 7 mm (leading edge of document) x 100 mm (width). No relationship to PRESCAN MODE

**Operation in monochrome auto copy mode:**

When the density of the document of the read area is light, output image density is increased by control. When the density of the document of the read area is dark, output image density is decreased by control.

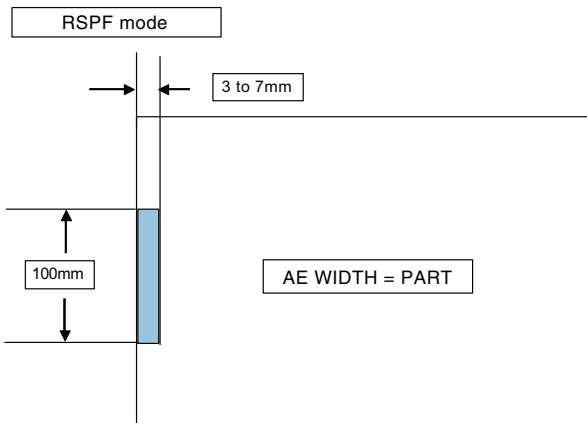
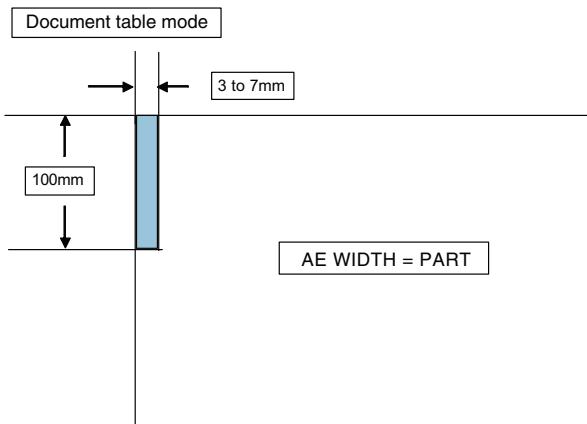
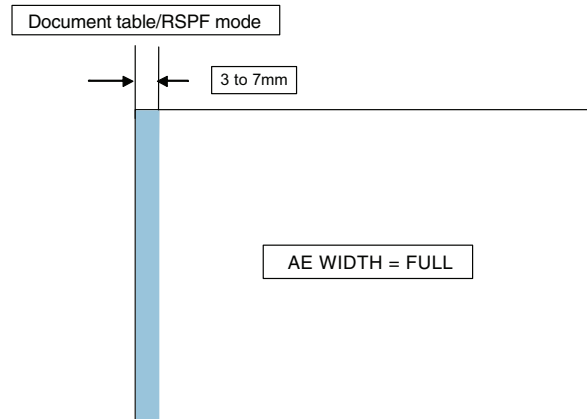

Document density detection area

**10-D (6)**

**Document low density image density reproduction adjustment in the automatic monochrome (Copy/Scan/FAX) mode (No need to adjust normally) (Background density adjustment in the scanning section)**

Use for the reproducibility adjustment of document background density in monochrome auto copy mode.

This adjustment is required in the following cases.

- \* When there is a desire not to reproduce the background of the document. When there is a desire to reproduce the low density image of the document.
- \* When there is request from the user.

- 1) Enter the SIM 46-32 mode.

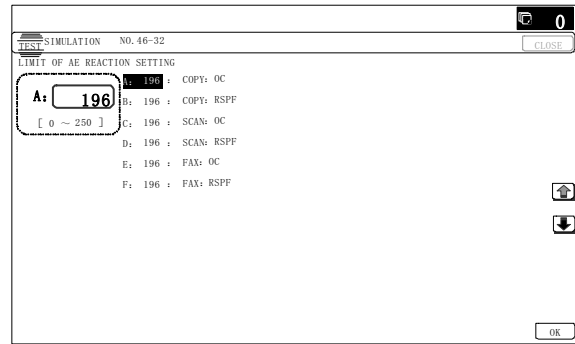

10-key

OK

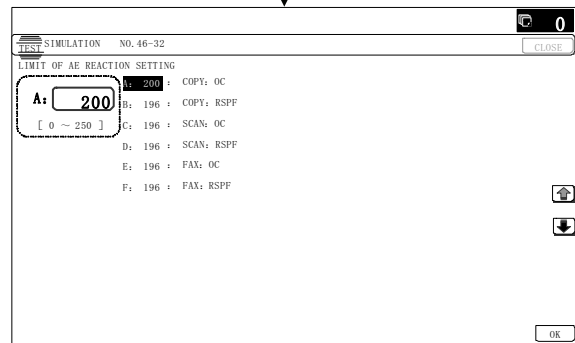

- 2) Select the adjustment mode with the scroll key.
- 3) Enter the adjustment value with 10-key and press [OK] key.

When the adjustment value is increased, reproducibility of the background and the low density image is increased. When the adjustment value is decreased, reproducibility of the background and the low density image is decreased.

Display/Item	Content	Set value	Default
A	COPY : OC	Copy mode (for OC)	1 - 250 196
B	COPY : RSPF	Copy mode (for RSPF)	1 - 250 196
C	SCAN : OC	Scanner mode (for OC)	1 - 250 196
D	SCAN : RSPF	Scanner mode (for RSPF)	1 - 250 196
E	FAX : OC	FAX mode (for OC)	1 - 250 196
F	FAX : RSPF	FAX mode (for RSPF)	1 - 250 196

**10-D (7)**

**Copy/Scan low density image density adjustment (for each mode)  
(No need to adjust normally)**

This adjustment is used to adjust the image density in the low density area in the copy/scanner mode.

This adjustment is required in the following cases.

- \* When there is a desire not to reproduce the background of the document. When there is a desire to reproduce the low density image of the document.
  - \* When there is request from the user.
- 1) Enter the SIM 46-63 mode.

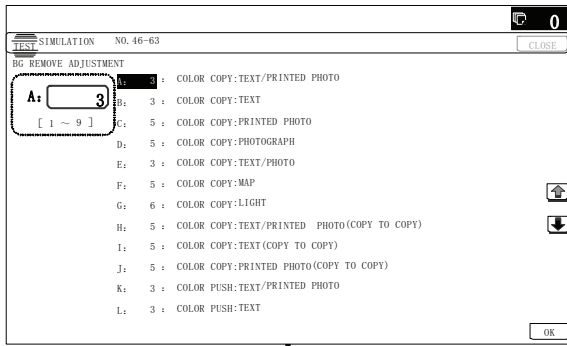

10-key

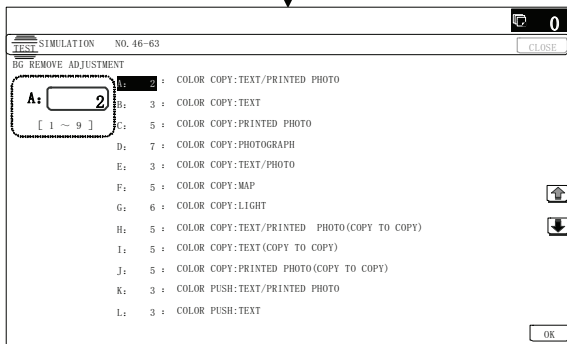

- 2) Select the copy mode to be adjusted with the scroll key.

Display/Item	Content	Set value	Default	
A	COLOR COPY : TEXT/PRINTED PHOTO	Text print (color copy)	1 - 9	3
B	COLOR COPY : TEXT	Text (color copy)	1 - 9	3
C	COLOR COPY : PRINTED PHOTO	Printed photo (color copy)	1 - 9	5
D	COLOR COPY : PHOTOGRAPH	Photograph (color copy)	1 - 9	5
E	COLOR COPY : TEXT/PHOTO	Text/Photograph (color copy)	1 - 9	3
F	COLOR COPY : MAP	Map (color copy)	1 - 9	5
G	COLOR COPY : LIGHT	Light document (color copy)	1 - 9	6
H	COLOR COPY : TEXT/PRINTED PHOTO (COPY TO COPY)	Copy document, Text print (color copy)	1 - 9	5
I	COLOR COPY : TEXT (COPY TO COPY)	Copy document, Text (color copy)	1 - 9	5
J	COLOR COPY : PRINTED PHOTO (COPY TO COPY)	Copy document, Printed photo (color copy)	1 - 9	5
K	COLOR PUSH:TEXT/PRINTED PHOTO	Text print (color PUSH)	1 - 9	3
L	COLOR PUSH:TEXT	Text (color PUSH)	1 - 9	3

	Display/Item	Content	Set value	Default
M	COLOR PUSH: PRINTED PHOTO	Printed photo (color PUSH)	1 - 9	5
N	COLOR PUSH: PHOTOGRAPH	Photograph (color PUSH)	1 - 9	5
O	COLOR PUSH: TEXT/PHOTO	Text/Photograph (color PUSH)	1 - 9	3
P	COLOR PUSH: MAP	Map (color PUSH)	1 - 9	5

- 3) Enter the adjustment value with 10-key and press [OK] key.  
When the adjustment value is increased, reproducibility of the background and the low density image is increased. When the adjustment value is decreased, reproducibility of the background and the low density image is decreased.

**10-D (8)**

**Color copy, text, line image reproduction adjustment (edge gamma, density adjustment) (Text, Map mode)  
(No need to adjust normally)**

**Adjustment 1**

By changing Text/Printed Photo, Text/Photograph, automatic copy mode Text, line image edge section gamma and the density, the reproducibility of text and line profile can be varied optionally.

With this adjustment, the density and the thickness of fine text and lines can be varied.

Check the result of this adjustment by text/printed photo copy mode (manual).

This adjustment is required in the following cases.

- \* When the reproducibility of text and line copy image is to be changed.
  - \* When there is request from the user.
- 1) Enter the SIM 46-27 mode.

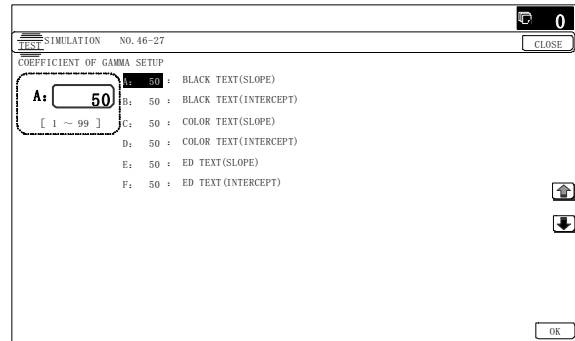

10-key

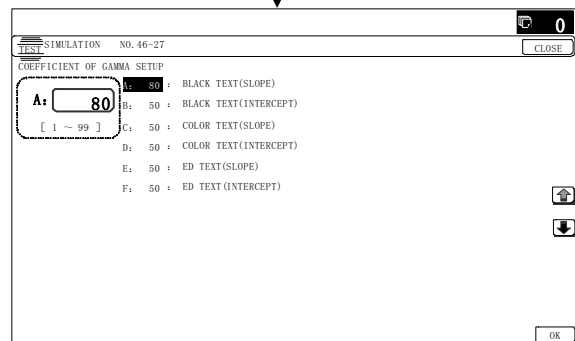

- 2) Select the mode to be adjusted with the scroll key.

	Display/Item (Copy mode)	Content	Adjust- ment range	Default
A	BLACK TEXT (SLOPE)*1	Black character edge gamma skew adjustment	1 - 99	50
B	BLACK TEXT (INTERCEPT)*1	Black character edge density adjustment	1 - 99	50
C	COLOR TEXT (SLOPE)*1	Color character edge gamma skew adjustment	1 - 99	50
D	COLOR TEXT (INTERCEPT)*1	Color character edge density adjustment	1 - 99	50
E	ED TEXT (SLOPE)	Text/Map mode gamma adjustment (Text/Map mode)	1 - 99	50
F	ED TEXT (INTERCEPT)	Text/Map mode density adjustment (Text/Map mode)	1 - 99	50

\*1: 20cpm machine: Disable without HDD.

- 3) Enter the adjustment value with 10-key.  
When the adjustment values of item A and C are changed, the gamma at the line edge section is changed.  
When the adjustment value is increased, the image contrast of character edge and line edge is increased. When the adjustment value is decreased, the image contrast of character and line edge is decreased.  
When the adjustment value of the adjustment item B and D are increased, the image density at the line edge section is increased, and vice versa.
- 4) Press [OK] key.
- 5) Make a copy in monochrome text/printed photo copy mode (manual), check the copy.  
When checking, use a copy of the document with a thin character and line image.  
If a satisfactory result is not obtained, return to the SIM 46-27 mode and change the adjustment value.  
Repeat the above procedures until a satisfactory result is obtained.

### Adjustment 2

This adjustment is used to change the gamma and the density in the Text/Map copy mode.

This adjustment is required in the following cases.

- \* To change the contrast and the density of the Text/Map copy mode images.
- \* When there is request from the user.

- 1) Enter the SIM 46-27 mode.

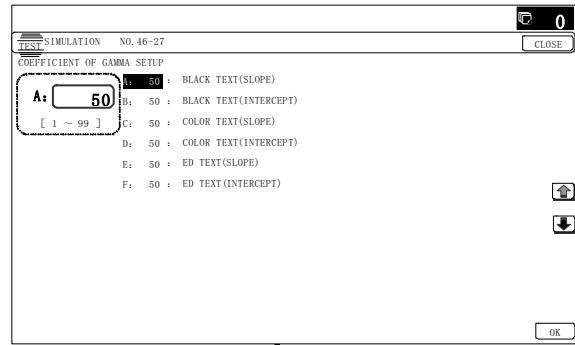

10-key

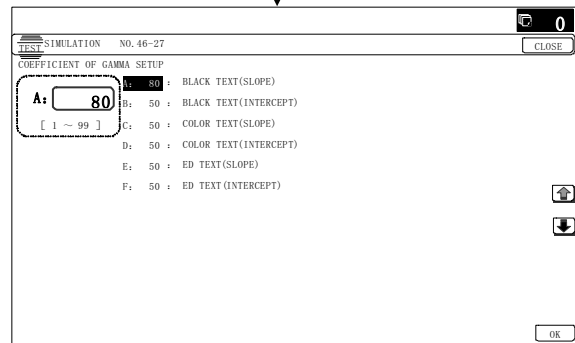

- 2) Select the mode to be adjusted with the scroll key.

	Display/Item (Copy mode)	Content	Adjust- ment range	Default
A	BLACK TEXT (SLOPE)*1	Black character edge gamma skew adjustment	1 - 99	50
B	BLACK TEXT (INTERCEPT)*1	Black character edge density adjustment	1 - 99	50
C	COLOR TEXT (SLOPE)*1	Color character edge gamma skew adjustment	1 - 99	50
D	COLOR TEXT (INTERCEPT)*1	Color character edge density adjustment	1 - 99	50
E	ED TEXT (SLOPE)	Text/Map mode gamma adjustment (Text/Map mode)	1 - 99	50
F	ED TEXT (INTERCEPT)	Text/Map mode density adjustment (Text/Map mode)	1 - 99	50

\*1: 20cpm machine: Disable without HDD.

- 3) Enter the adjustment value with 10-key.  
When the adjustment value of the adjustment item E is changed, the gamma (contrast) is changed.  
When the adjustment value is increased, the contrast is increased, and vice versa.  
When the adjustment value of the adjustment item F is increased, the image density is increased, and vice versa.
- 4) Press [OK] key.
- 5) Make a copy in the Text/Map copy mode (manual), and check the output print.  
If a satisfactory result is not obtained, use SIM46-27 to change the adjustment value.  
Repeat the above procedures until a satisfactory result is obtained.

**10-D (9)**

**Monochrome (Copy/Scan/FAX) mode color document reproduction adjustment (No need to adjust normally)**

Use to adjust the reproducibility for the red image and the yellow image when printing color document that included the red/yellow image in monochrome copy mode.

This adjustment is required in the following cases.

- \* When there is desire to change reproducibility of yellow/red image in case of making a color copy of the color document in monochrome copy mode.
- \* When there is request from the user.

1) Enter the SIM 46-37 mode.

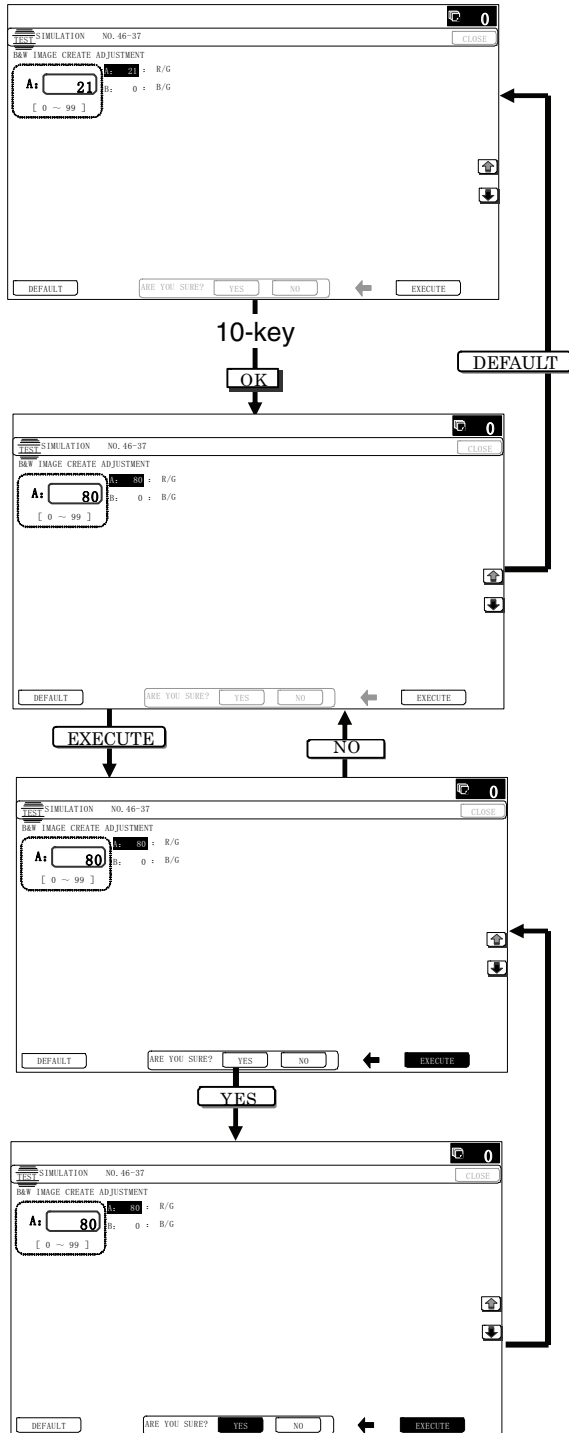

2) Select the mode to be adjusted with the scroll key.

Display/Item (Copy mode)	Content	Adjustment range	Default	
A	R/G	Gray making setting (R/G)	0 - 99	21
B	B/G	Gray making setting (B/G)	0 - 99	0

3) Enter the adjustment value with 10-key.

When the adjustment value of adjustment item A is increased, copy density of red image is decreased. When the adjustment value is decreased, copy density of red image is increased.

When the adjustment value of adjustment item B is increased, copy density of red image is increased. When the adjustment value is decreased, copy density of red image is decreased.

4) Press [OK] key.

5) Make a copy in monochrome text/printed photo copy mode (manual), check the copy.

If a satisfactory result is not obtained, return to the SIM 46-37 mode and change the adjustment value.

Repeat the above procedures until a satisfactory result is obtained.

**10-D (10)**

**Color copy mode dark area gradation (black component quantity) adjustment (No need to adjust normally)**

Use to adjust the black ingredient amount in the color copy mode. (except character and line image)

As a result of this adjustment, the gradation of the shade part changes.

This adjustment is required in the following cases.

- \* When reproduction as solid of black image is required.
- \* To make the black background and the dark area darker
- \* When change of gradation of the shade part is required.
- \* When there is request from the user.

1) Enter the SIM 46-38 mode.

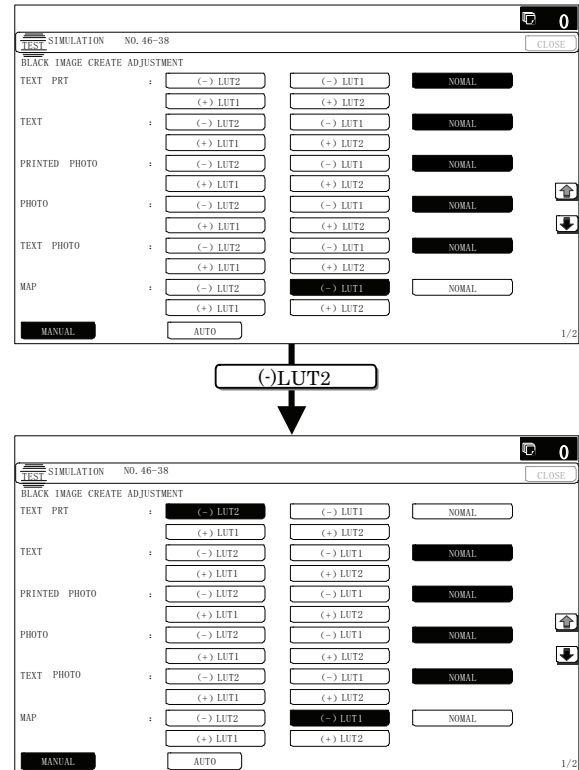

- 2) Select the AUTO MODE or the MANUAL MODE with the mode key.
- 3) Select the mode to be adjusted with the scroll key.

Display/Item (Copy mode)	Select button	Content	Default	
MANUAL	TEXT PRT	(-) LUT2	Text print (Manual)	NORMAL
		(-) LUT1		
		NOMAL		
		(+) LUT1		
	TEXT	(-) LUT2	Text (Manual)	NORMAL
		(-) LUT1		
		NOMAL		
		(+) LUT1		
	PRINTED PHOTO	(-) LUT2	Printed photo (Manual)	NORMAL
		(-) LUT1		
		NOMAL		
		(+) LUT1		
PHOTO	(-) LUT2	Photograph (Manual)	NORMAL	
	(-) LUT1			
	NOMAL			
	(+) LUT1			
TEXT PHOTO	(-) LUT2	Text/ Photograph (Manual)	NORMAL	
	(-) LUT1			
	NOMAL			
	(+) LUT1			
MAP	(-) LUT2	Map (Manual)	(+) LUT1	
	(-) LUT1			
	NOMAL			
	(+) LUT1			
CP ORG/ TEXT PRT	(-) LUT2	Copy document/ Text printed (Manual)	NORMAL	
	(-) LUT1			
	NOMAL			
	(+) LUT1			
COPY ORG/ TEXT	(-) LUT2	Copy document/ Text (Manual)	NORMAL	
	(-) LUT1			
	NOMAL			
	(+) LUT1			
COPY ORG/ PHOTO	(-) LUT2	Copy document/ Printed photo (Manual)	NORMAL	
	(-) LUT1			
	NOMAL			
	(+) LUT1			
LIGHT ORIGINAL	(-) LUT2	Light document (Manual)	(+) LUT1	
	(-) LUT1			
	NOMAL			
	(+) LUT1			

Display/Item (Copy mode)	Select button	Content	Default	
AUTO	AUTO0	(-) LUT2	Auto mode judgment 0	NORMAL
		(-) LUT1		
		NOMAL		
		(+) LUT1		
	AUTO1	(-) LUT2	Auto mode judgment 1	NORMAL
		(-) LUT1		
		NOMAL		
		(+) LUT1		
	AUTO2	(-) LUT2	Auto mode judgment 2	NORMAL
		(-) LUT1		
		NOMAL		
		(+) LUT1		
AUTO3	(-) LUT2	Auto mode judgment 3	NORMAL	
	(-) LUT1			
	NOMAL			
	(+) LUT1			
AUTO4	(-) LUT2	Auto mode judgment 4	NORMAL	
	(-) LUT1			
	NOMAL			
	(+) LUT1			
AUTO5	(-) LUT2	Auto mode judgment 5	NORMAL	
	(-) LUT1			
	NOMAL			
	(+) LUT1			
AUTO6	(-) LUT2	Auto mode judgment 6	NORMAL	
	(-) LUT1			
	NOMAL			
	(+) LUT1			

- 4) Press the black ingredient amount select button.  
When reproduction as solid of black image is required:  
Selects + button  
When there is desire to darken copy of black image:  
Selects + button  
When a dark color image is reproduced in the black:  
Selects - button
- 5) Make a copy in color copy mode and check the copy.  
If a satisfactory result is not obtained, return to the SIM 46-38 mode and change the adjustment value.  
Repeat the above procedures until a satisfactory result is obtained.

### **10-D (11)** **Color (Copy/Scan) mode sharpness adjustment (No need to adjust normally)**

Use for sharpness adjustment of the high density image in color copy mode.

This adjustment changes smoothness (asperity) in the image shade part.

This adjustment is required in the following cases.

- \* When changing the sharpness of copy image in copy mode. (obtain crispy image) (decreases moire)
- \* When there is desire to improving smoothness in the image shade part (for decrease of asperity)
- \* To make the black background and the dark area darker.
- \* To reproduce the gradation change in the dark area.
- \* When there is request from the user.

1) Enter the SIM 46-60 mode.

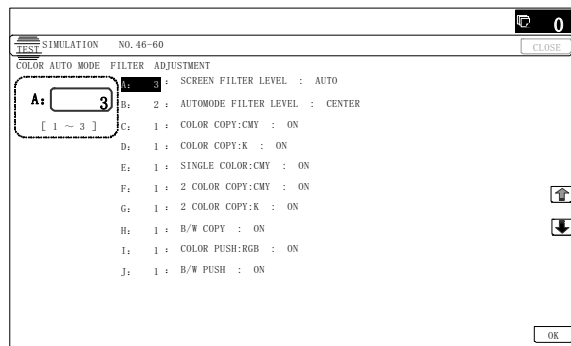

10-key

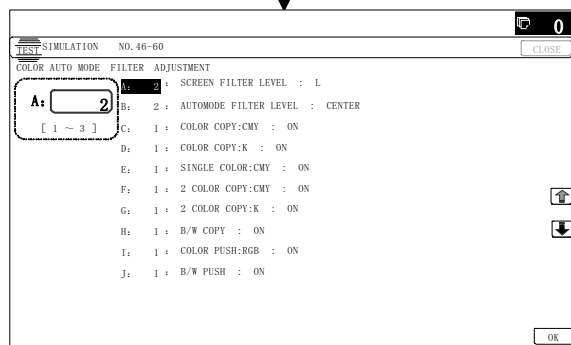

2) Select the mode to be adjusted with the scroll key.

Display/Item		Content		Setting range	Default	NOTE	
A	SCREEN FILTER LEVEL	H	Sharpness (filter) adjustment of dot pattern image in auto copy mode	Strong emphasis	1	3 (Auto)	Apply to auto copy mode only
		L		Soft emphasis	2		
		AUTO		Auto	3		
B	AUTOMODE FILTER LEVEL	SOFT	Sharpness (filter) adjustment for the auto copy mode	SOFT	1	2 (CENTER)	
		CENTER		CENTER	2		
		HIGH		HIGH	3		
C	COLOR COPY: CMY	OFF	Soft filter applying setting to C, M, Y image in color copy mode	OFF	0	1 (ON)	Available for the high density image except text and line image
		ON		ON	1		
D	COLOR COPY:K	OFF	Soft filter applying setting to K image in color copy mode	OFF	0	1 (ON)	
		ON		ON	1		
E	SINGLE COLOD: CMY	OFF	Soft filter applying setting to C, M, Y image in single color copy mode	OFF	0	1 (ON)	When setting ON, smoothness in the image shade part improves by applying soft filter. (asperity decreases)
		ON		ON	1		
F	2 COLOR COPY: CMY	OFF	Soft filter applying setting to C, M, Y image in 2-color copy mode	OFF	0	1 (ON)	
		ON		ON	1		
G	2 COLOR COPY: K	OFF	Soft filter applying setting to K image in color copy mode	OFF	0	1 (ON)	
		ON		ON	1		
H	B/W COPY	OFF	Soft filter applying setting in monochrome copy mode	OFF	0	1 (ON)	
		ON		ON	1		
I	COLOR PUSH: RGB	OFF	Soft filter applying setting to image in push scan color mode	OFF	0	1 (ON)	
		ON		ON	1		
J	B/W PUSH	OFF	Soft filter applying setting to image in push scan monochrome mode	OFF	0	1(ON)	
		ON		ON	1		

3) Input numeric value corresponding to sharpness level (filter process mode).

• Adjustment item A:

When selecting AUTO, filter is selected according to dot pattern state automatically and adjusts sharpness.

Input small numeric value to obtain crispy image. Input large numeric value to decrease moire.

• Adjustment item B:

Select HIGH to obtain clear images. Select SOFT to reduce moire.

• Adjustment item C - J:

When setting ON, smoothness in the image shade part improves by applying soft filter. (asperity decreases)

4) Press [OK] key.

5) Make a copy and check the copy image.

If a satisfactory result is not obtained, return to the SIM 46-60 mode and change the adjustment value.

Repeat the above procedures until a satisfactory result is obtained.

**10-D (12)**

**Copy high density image density reproduction setting (Normally unnecessary to the setting change)**

If a tone gap occurs on part of high density in copy mode, or if there is necessity to increase the density of the part of high density, change the setting.

This setting is normally not required. When, however, there are case of following, change the setting.

- \* When a tone gap occurs on part of high density.
- \* When there is a necessity to increase the density of the part of high density.
- \* When there is request from the user.

**a. Adjustment procedure**

1) Enter the SIM 46-23 mode.

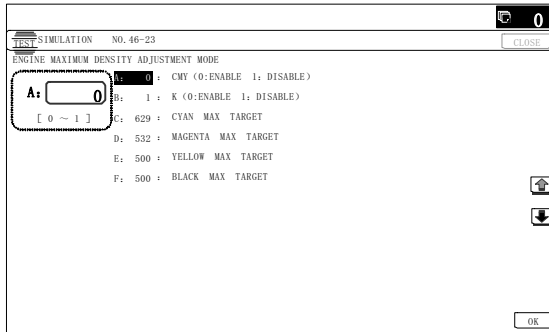

10-key

OK

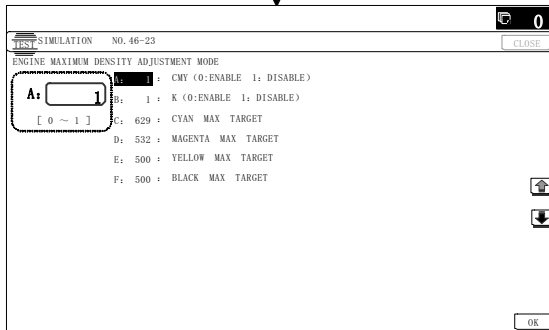

2) Select the item A, B with the scroll key.

Display/Item	Content	Setting range	Default
A	0 CMY (0:ENABLE 1:DISABLE)	0 - 1	0
	1 CMY engine maximum density correction mode Enable		
B	0 K (0:ENABLE 1:DISABLE)	0 - 1	1
	1 K engine maximum density correction mode Disable		
C	CYAN MAX TARGET	0 - 999	500
D	MAGENTA MAX TARGET	0 - 999	500
E	YELLOW MAX TARGET	0 - 999	500
F	BLACK MAX TARGET	0 - 999	500

- \* If a tone gap occurs on part of high density, set 0 to item A and B. The density of high density part decreases. However, the tone gap is better.
- \* In case of more increase of the density on high density part, set 1 to item A and B. The tone gap may occur in high density part.

**Important**

Do not change the setting values of item C, D, E and F. If these values are changed, density of the high density part is changed. If these values are changed, be sure to execute the copy color balance density adjustment. (Auto adjustment)



**10-D (13)**

**Copy color balance adjustment  
(Single color copy mode)  
(No need to adjust normally)**

This adjustment is used to set the color balance and the density in the single color copy mode to the user's request.

The adjustment is made by changing Y, M, C components of each color.

This adjustment is not required normally, but executed when there is a request from the user.

When the default adjustment value is changed, this adjustment is required in the following cases.

- \* When it is required to change the color balance in the single color copy mode.
- \* When there is request from the user.

**a. Adjustment procedure**

- 1) Enter the SIM 46-25 mode.

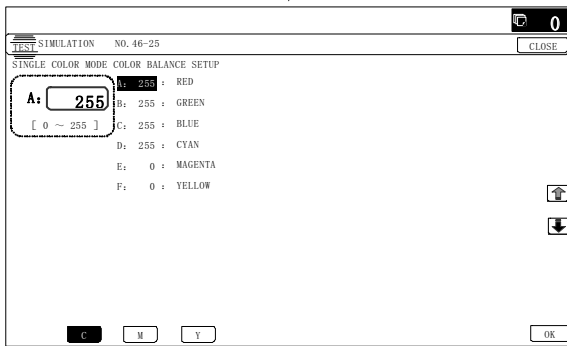
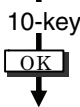
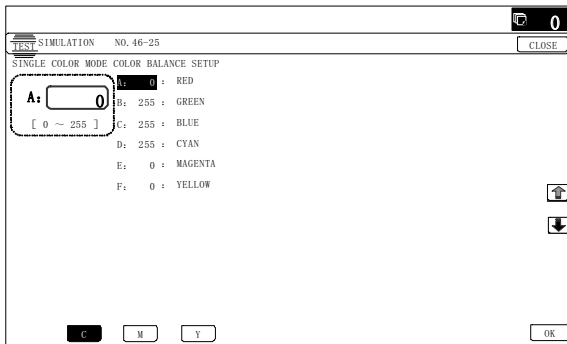

- 2) Select the color to be adjusted with the scroll key.
- 3) Select the color (YMC) to be adjusted with the color key.
- 4) Enter the adjustment value with 10-key.

Display/Item	Adjustment range	Default		
		C	M	Y
A RED	0 - 255	0	255	200
B GREEN	0 - 255	255	0	255
C BLUE	0 - 255	255	200	0
D YELLOW	0 - 255	0	0	255
E MAGENTA	0 - 255	0	255	0
F CYAN	0 - 255	255	0	0

- 5) Press [OK] key.
- 6) Make a copy in the single color copy mode and check the copy.

If a satisfactory result is not obtained, return to the SIM 46-25 mode and change the adjustment value.

Repeat the above procedures until a satisfactory result is obtained.

**10-D (14)**

**RSPF mode (Copy/Scan/FAX) density adjustment (No need to adjust normally)**

This setting is normally not required, however, in the following cases, make changes to the setting:

- \* When copy in RSPF mode differs from copy in document table mode.
- \* When copy density in RSPF mode is low or too high.
- \* When the RSPF unit is replaced.
- \* When the RSPF unit is disassembled.
- \* The CCD unit has been replaced.
- \* U2 trouble has occurred.
- \* When the MFP PWB is replaced.
- \* When the EEPROM on the MFP PWB is replaced.

**a. Adjustment procedure**

- 1) Enter the SIM 46-9 mode.

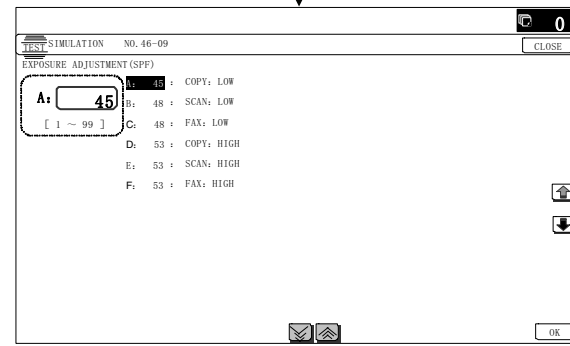
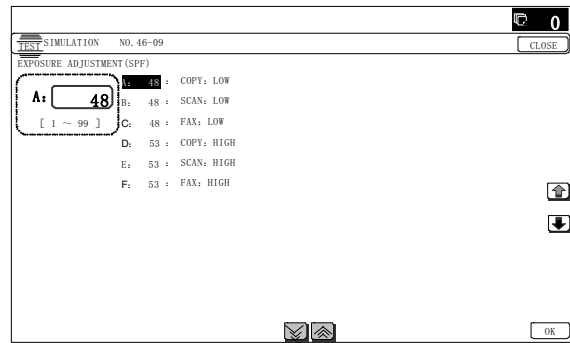

- 2) Select the mode to be adjusted with the scroll key.  
When adjusting density on low density part, select "A (COPY LOW)". When adjusting density on high density part, select "D (COPY HIGH)".

Item/Display	Content	Setting range	Default
A COPY : LOW	RSPF copy mode exposure adjustment (Low density side)	1 - 99	48
B SCAN : LOW	RSPF scanner mode exposure adjustment (Low density side)	1 - 99	48
C FAX : LOW	PSPF FAX mode exposure adjustment (Low density side)	1 - 99	48
D COPY : HIGH	RSPF copy mode exposure adjustment (High density side)	1 - 99	53
E SCAN : HIGH	RSPF scanner mode exposure adjustment (Low density side)	1 - 99	53
F FAX : HIGH	RSPF FAX mode exposure adjustment (High density side)	1 - 99	53

- 3) Enter the adjustment value with 10-key.  
In case of increase of image density, input large numeric value. Or in case of diluting the image density, input small numeric value.
  - 4) Press [OK] key.
  - 5) Make a copy in the RSPF mode and check the copy.
- If a satisfactory result is not obtained, return to the SIM 46-9 mode and change the adjustment value.  
Repeat the above procedures until a satisfactory result is obtained.

## 10-D (15) Automatic color balance adjustment by the user (Copy color balance automatic adjustment ENABLE setting and adjustment)

### a. General

In the user program mode, the user can execute the auto color calibration (auto adjustment of the copy color balance and density). This adjustment is to set Enable/Disable of the above user operation with SIM 26-53.

#### Important

This setting must be set to ENABLE only when the user's understanding on the automatic adjustment of the copy color balance and density and the user's operational ability are judged adequate enough to execute the adjustment.

When set to enable, operation procedures must be fully explained to the user.

### b. Setting procedure

- 1) Enter the SIM 26-53 mode.

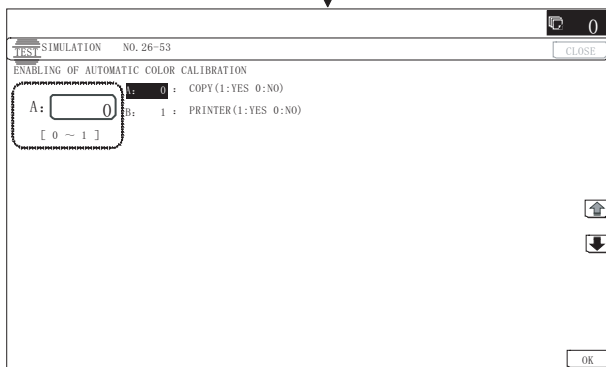
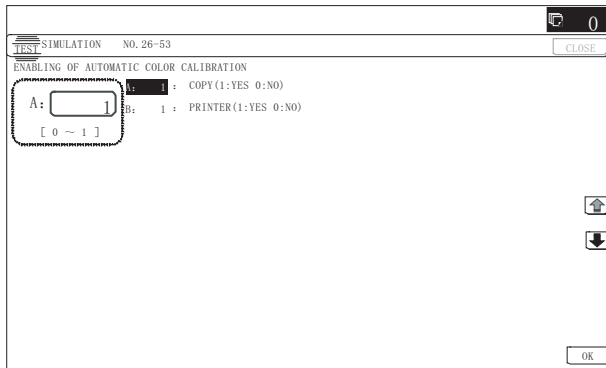

- 2) Select ENABLE or DISABLE with 10-key.  
When disabling, set to "0" (NO). When enabling, set to "1" (Yes).
- 3) Press [OK] key.

When set to DISABLE, the menu of the user auto color calibration (automatic adjustment of copy color balance and density) is not displayed in the user program mode.

### (Auto color calibration by the user (Auto color balance adjustment))

#### Important

This adjustment is based on the service target color balance set with SIM 63-7 and SIM 63-8. If, therefore, the above settings are not properly performed, this adjustment cannot be made properly.

- 1) Enter the system setting mode.
- 2) Enter the copy setting mode.
- 3) Press the auto color calibration key.
- 4) Press [EXECUTE] key.

The color patch image (adjustment pattern) is printed out.

- 5) Set the color patch image (adjustment pattern) printed in procedure 4) on the document table.

Set the patch image so that the thin line is on the left side as shown in the figure.

At that time, place 5 sheets of white paper on the above color patch image (adjustment pattern).

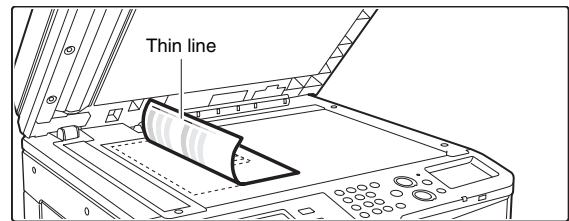

- 6) Press [EXECUTE] key, and the copy color balance adjustment is executed automatically. After completion of the adjustment, the display returns to the original operation screen.

For the 26cpm/36cpm/31cpm(A) machines, the message, "Will you go on to the printer color balance adjustment?" is displayed.

To execute the printer color balance adjustment successively, perform the procedures same as the above.

**10-D (16)**

**Copy gamma, color balance adjustment for each dither (Automatic adjustment)**

**a. General**

This simulation is used to improve the image quality in a certain mode. (Refer to the list in procedure 6.)

**b. Adjustment procedures**

- 1) Enter the SIM46-54 mode.
- 2) Press [EXECUTE] key.  
A4/11" x 8.5" or A3/11" x 17" paper is automatically selected. The color patch image (adjustment pattern) is printed.
- 3) Set the patch image (adjustment pattern) printed in the procedure 2) on the document table so that the thin lines on the printed patch image (adjustment pattern) are on the left side. Place 5 sheets of white paper on the printed patch image (adjustment pattern).



- 4) Press [EXECUTE] key.  
The color balance and the density are automatically adjusted. The adjustment pattern is printed out. Check it for any abnormality.
- 5) Press [OK] key.  
The list of the adjustment items (for each dither) is displayed.
- 6) Select an adjustment item (for each dither).

Select item (Mode/Image)	Content	NOTE
Heavy Paper*1	Adjustment item to improve the color balance in the heavy paper mode	20cpm machine: Disable without HDD.
Black Edge	Adjustment item (K) to improve the reproduction of lines, text density, and thickness	
Color Edge	Adjustment item (Color) to improve the reproduction of lines, text density, and thickness	
B/W	Adjustment item to improve the density and gradation in the monochrome text mode and the map mode.	20cpm machine: Reflected in all the modes.
Color Ed	Adjustment item to improve the color balance in the text mode and the map mode.	
B/W 600dpi	Adjustment item to improve the density and gradation in the monochrome printed photo mode and the photography mode.	20cpm machine: Disable without HDD.

Select item (Mode/Image)	Content	NOTE
WOVEN1*2	Adjustment item when adjusting the watermark density in the watermark mode 1	20cpm/23cpm/31cpm(G) machine: Disable
WOVEN2*2	Adjustment item when adjusting the watermark density in the watermark mode 2	
WOVEN3*2	Adjustment item when adjusting the watermark density in the watermark mode 3	
WOVEN4*2	Adjustment item when adjusting the watermark density in the watermark mode 4	

\*1: When performing adjustments in the heavy paper mode, load paper in the manual paper feed tray.

\*2: 23cpm/31cpm(G) machine: Disable

- 7) Press [EXECUTE] key.  
A4/11" x 8.5" or A3/11" x 17" paper is automatically selected. The patch image (adjustment pattern) is printed out. In the monochrome mode, only the monochrome pattern is printed.
- 8) Set the patch image (adjustment pattern) printed in the procedure 7) on the document table so that the thin lines on the printed patch image (adjustment pattern) are on the left side. Place 5 sheets of white paper on the printed patch image (adjustment pattern).

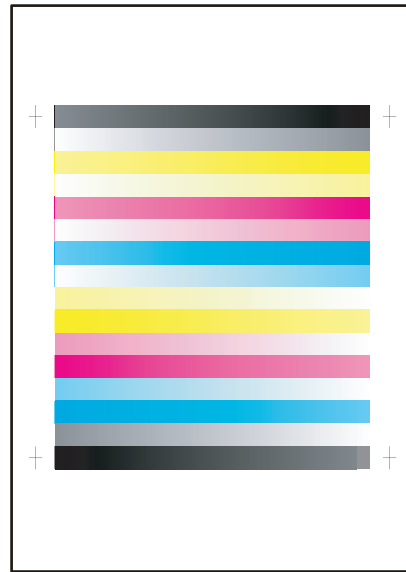

- 9) Press [EXECUTE] key.  
The color balance and the density are automatically adjusted, and the machine goes to the state of procedure 6). To complete the adjustment and enable the adjustment result, press [OK] key.
- 10) Make a copy, and check the copy image quality. (Refer to the item of the printer color balance and density check.)

**Note**

Use SIM46-52 to reset the adjustment values to the default values.

**10-D (17)**

**Dropout color adjustment  
(Normally not required.)  
(26cpm/36cpm/31cpm(A) machine)**

General (Purpose):

This adjustment is used to adjust the range of reproduction of color document images as monochrome images in the image send mode (monochrome manual text mode).

In other words, it is used to adjust the level of chroma of color images which are reproduced as monochrome images.

This adjustment must be performed in the following cases:

\* When there is request from the user.

- 1) Enter the SIM 46-55 mode.
- 2) Enter the adjustment value with 10-key and press [OK] key.  
When the adjustment value is increased, colors dropout becomes easy to narrow the reproduction range. When the adjustment value is decreased, color dropout becomes difficult to widen the reproduction range.

Item/Display	Content	Setting range	Default value	
A	CHROMA	Dropout color range adjustment	0 - 6	3

- 3) Scan the document in the image send mode (monochrome manual text mode) and check the adjustment result.

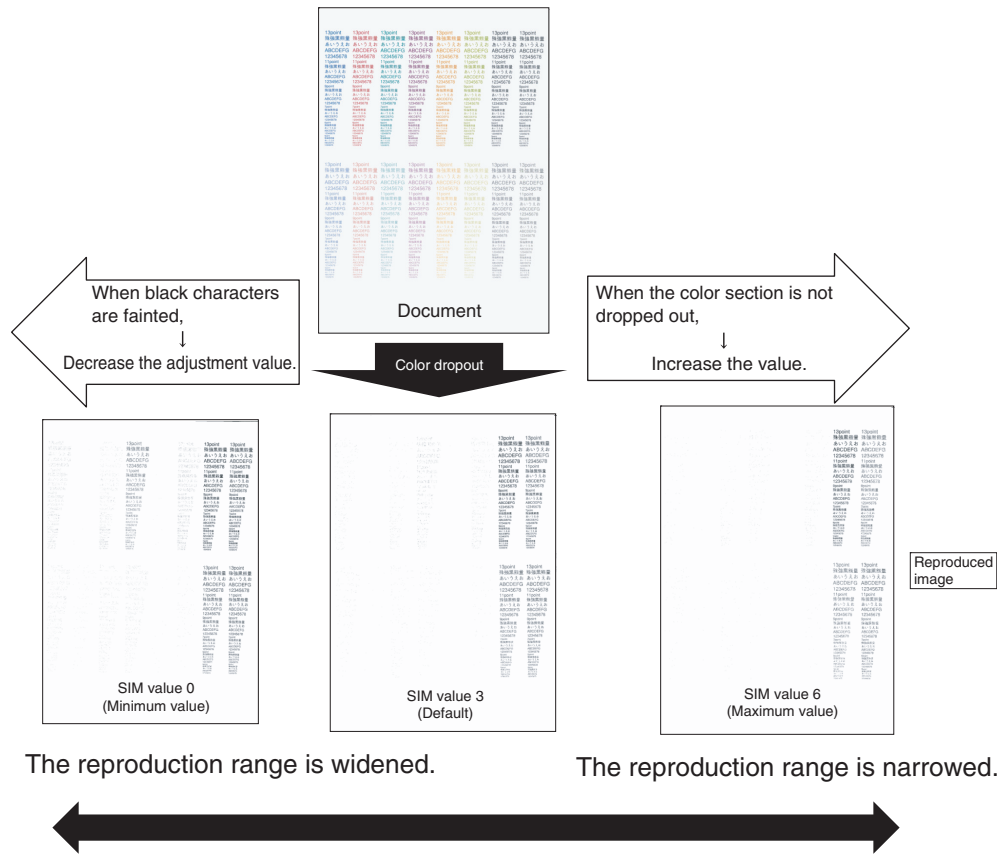

**Effect and adverse effect when decreasing the value**

**[Effect]**

When black characters are faded by color shift, etc, the black area is outputted clearly.

**[Adverse effect]**

Dropout of color sections becomes difficult.

**Effect and adverse effect when increasing the value**

**[Effect]**

Colors (of low chroma) which are difficult to be dropped out can be dropped out.

**[Adverse effect]**

Black characters are faded or cracked.

**10-D (18)****Watermark adjustment  
(Normally not required)  
(26cpm/36cpm/31cpm(A) machine)**

General (Purpose):

This adjustment is used to adjust the reproduction capability of the watermark in the copy/printer mode.

This adjustment is used for watermark documents (primary output). The result of this adjustment affects the result of watermark print (secondary output).

In the printer mode, the watermark density can be adjusted by the printer driver. That adjustment is based on the result of this adjustment.

This adjustment must be performed in the following cases:

- \* When there is request from the user. (When a satisfactory result is not obtained from the adjustment in the system setting mode.)
  - \* When there is request from the user. (When a satisfactory result is not obtained from the adjustment with the printer driver.)
- 1) Enter the SIM 46-66 mode.
  - 2) Select the PATTERN mode, then select an adjustment item in the following list according to the situation.

**Note**

Normally there is no need to adjust the PATTERN mode (items K and L), the COPY MODE, and the POSITION mode.

Item/Display	Content	Setting range	Default value	Description	NOTE
A	WOVEN DEN BK LOW	Watermark density level (Color: Black / Adjustment for light images)	0 - 255	15	<p>The adjustment value is changed to increase or decrease the density of the watermark of background documents (primary output). To increase the watermark density, increase the adjustment value. To decrease the watermark density, decrease the adjustment value.</p> <p><b>Important</b></p> <p>When the adjustment value is increased, the watermark area which is originally not reproduced becomes difficult to disappear. When the adjustment value is decreased, the watermark area which is originally reproduced becomes easy to disappear.</p>
B	WOVEN DEN BK MIDDLE	Watermark density level (Color: Black, Density: Standard)	0 - 255	19	
C	WOVEN DEN BK HIGH	Watermark density level (Color: Black, Density: Dark)	0 - 255	23	
D	WOVEN DEN C LOW	Watermark density level (Color: Cyan / Adjustment for light images)	0 - 255	19	
E	WOVEN DEN C MIDDLE	Watermark density level (Color: Cyan, Density: Standard)	0 - 255	23	
F	WOVEN DEN C HIGH	Watermark density level (Color: Cyan, Density: Dark)	0 - 255	27	
G	WOVEN DEN M LOW	Watermark density level (Color: Magenta / Adjustment for light images)	0 - 255	15	
H	WOVEN DEN M MIDDLE	Watermark density level (Color: Magenta, Density: Standard)	0 - 255	18	
I	WOVEN DEN M HIGH	Watermark density level (Color: Magenta, Density: Dark)	0 - 255	21	
J	CONTRAST	Contrast adjustment	0 - 255	2	
K	HT TYPE (POSI)	For half-tone index watermark type positive	42 - 43	42	Normally set to the default.
L	HT TYPE (NEGA)	For half-tone index watermark type negative	42 - 43	42	To reproduce the containing characters of watermark copy (secondary output) more clearly, set to 43. In that case, however, the containing characters of the watermark document (primary output) can be easily reproduced.

## Changing adjustment values of adjustment items A - I and trade off

Kinds of watermarks (Mode selected in the watermark copy mode)	Density value	Adjustment values of adjustment items A - I	Effect
Characters appearing.	Decrease.	The adjustment value is decreased.	The watermark images become easy to disappear. The containing characters become lighter.
	Increase.	The adjustment value is increased.	The containing characters become darker. The watermark images become difficult to disappear.
Background appearing.	Decrease.	The adjustment value is decreased.	The containing characters become easy to disappear. The watermark images become easy to disappear.
	Increase.	The adjustment value is increased.	The watermark images become darker. The containing characters become difficult to disappear.

- 3) Enter the adjustment value with 10-key and press [OK] key.
- 4) Make a copy, and check the adjustment result.

### Descriptions on the watermark

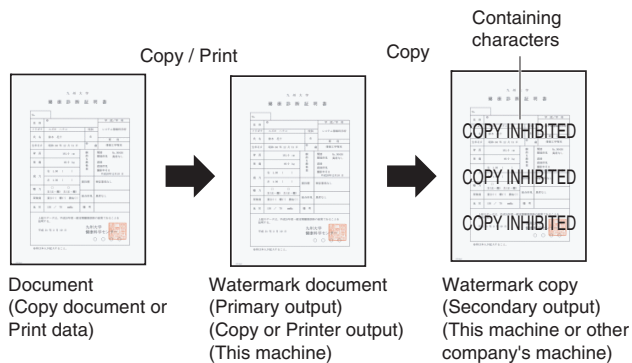

Watermark color	The watermark color is available in Cyan, Magenta, and Black.
Containing characters	Characters embedded in a watermark, such as "COPY INHIBITED," are called containing characters.
Kinds of watermarks	There are two kinds: "Character appearing" and "Background appearing." When a watermark of "Character appearing" is copied, the background disappears and the containing characters appear. When a watermark of "Background appearing" is copied, the watermark of the character area disappears and the containing characters become outline characters.
Principle of watermarks	A watermark is composed of two dots: fine dots and rough dots. Since fine dots disappear when copied, they are called disappearing patterns. Since rough dots remain when copied, they are called remaining patterns. In a watermark of "Character appearing," the background is a disappearing pattern and the containing characters are remaining patterns. In a watermark of "Background appearing," the background is a remaining pattern and the containing characters are disappearing patterns.
<b>Important</b> Note for watermarks	Watermarks have the following characteristics: <ul style="list-style-type: none"> <li>• A watermark is presumed to be synthesized with text documents. If it is used with photos or images, the containing characters may be seen in the watermark document (primary output) or the containing characters may not appear properly in the watermark copy (secondary output).</li> <li>• When a watermark is synthesized with newspapers or other dark-background documents, the containing characters may not appear in the watermark copy (secondary output).</li> <li>• Containing characters may not appear in the watermark copy (secondary output) depending on the kind of the copier which makes the watermark copy (secondary output) and the copy mode.</li> <li>• Containing characters may not appear clearly in the watermark copy (secondary output) depending on the copy mode in which the watermark document (primary output) is made.</li> <li>• When the print engine status changes, the containing characters may not be concealed properly in the watermark document (primary output). In this case, follow the procedures below to conceal the containing characters. <ul style="list-style-type: none"> <li>* Use SIM46-24 to execute the color balance adjustment.</li> <li>* Use SIM46-54 to execute the color balance adjustment for each dither.</li> <li>* Adjust the watermark print contrast in the system setting.</li> </ul> </li> <li>• Though the watermark of cyan or magenta is selected in the black and white mode, the black watermark is synthesized.</li> <li>• For a document which is judged as monochrome with ACS selected, though the watermark color is specified as cyan or magenta, the black watermark is synthesized.</li> <li>• The preview screen of the watermark only indicates the setting of the watermark color, and does not indicate an actual copy image.</li> <li>• When the document control (printer mode) is used together, it is advisable to use "Characters appearing" setting. If "Background appearing" setting is used together, the detection accuracy of document control may be reduced.</li> <li>• In the printer mode watermark, setting of 1200dpi and a watermark cannot be used together.</li> </ul>

## Watermark adjustment in the system setting

System setting → Security setting → Watermark print → Contrast tab

Watermark kind mode selection	Density	Adjustment
Character appearing	To increase the text density	Decrease the contrast value. (Default: 5)
	To decrease the text density	Increase the contrast value. (Default value: 5)
Background appearing	To increase the text density	Increase the contrast value. (Default value: 5)
	To decrease the text density	Decrease the contrast value. (Default: 5)

### Important

#### Note for adjusting the watermark with SIM46-54

When the color balance automatic adjustment is executed with SIM46-74 or SIM46-24 but the containing characters are reproduced, use SIM46-54 to execute the color balance automatic adjustment for each dither.

However, note the following items.

- When either of item K or L of the PATTERN mode is 42, the adjustment must be executed for the both modes of WOVEN1 and WOVEN2 of SIM46-54.
- When either of item K or L of the PATTERN mode is 43, the adjustment must be executed for the both modes of WOVEN3 and WOVEN4 of SIM46-54.
- WOVEN1 and WOVEN2 must be adjusted in a pair as well as WOVEN3 and WOVEN4.

If it is ignored, the containing characters remain reproduced.

## 10-E Printer image quality adjustment (Basic adjustment)

### Requisite condition before execution of the printer color balance/density adjustment

Before execution of the printer color balance/density adjustment, the copy color balance/density adjustment must have been completed properly.

#### This adjustment is required in the following cases.

- \* Basically same as when the copy color balance/density adjustment is required.
- \* After the copy color balance/density adjustment.

## 10-E (1) Printer color balance adjustment (Automatic adjustment)

### a. General

The color balance adjustment (auto adjustment) is used to adjust the print density of each color (Cyan, Magenta, Yellow, Black) automatically with SIM 67-24 or the user program.

When this adjustment is executed, the color balance adjustments of all the print modes are revised.

There are following two modes in the auto color balance adjustment.

- 1) Auto color balance adjustment by the serviceman (SIM 67-24 is used.)
- 2) Auto color balance adjustment by the user (The user program mode is used.) (The color balance target is the service target.)

The auto color balance adjustment by the user is provided to reduce the number of service calls.

If the print color balance is lost for some reasons, the user can use this color balance adjustment to recover the balance.

When, however, the machine has a fatal problem or when the machine condition is greatly changed, this function does not work effectively.

On the other hand, the auto color balance adjustment by the serviceman functions to recover the normal color balance though the machine condition is greatly changed. If the machine has a fatal problem, repair and adjust it for obtaining the normal color balance.

To perform the adjustment, the above difference must be fully understood.

**b. Adjustment procedure**

(Auto color balance adjustment by the serviceman)

Printer color balance and density adjustment (Automatic adjustment) procedure flowchart (SIM67-24)

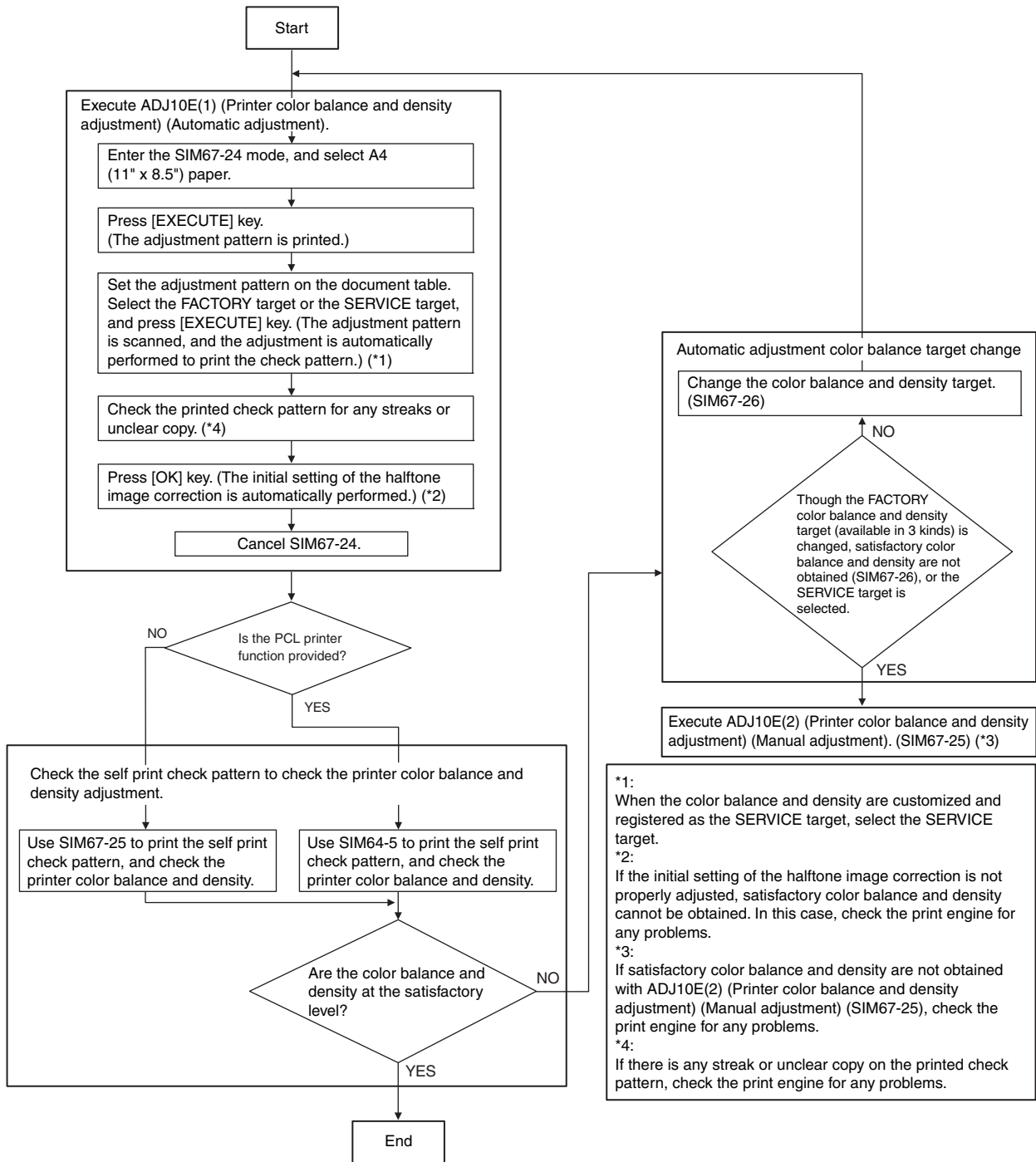



- 1) Enter the SIM 67-24 mode.

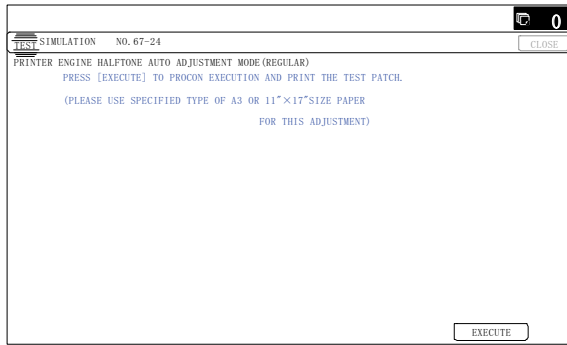

- 2) Press [EXECUTE] key. (A4/11" x 8.5" or A3/11" x 17" paper is automatically selected.)

The color patch image (adjustment pattern) is printed out.

- 3) Set the color patch image (adjustment pattern) paper printed in procedure 2) on the document table.

Place the printed color patch image (adjustment pattern) paper on the document table so that the thin lines on the paper are on the left side. Place 5 sheets of white paper on the printed color patch image (adjustment pattern) paper.

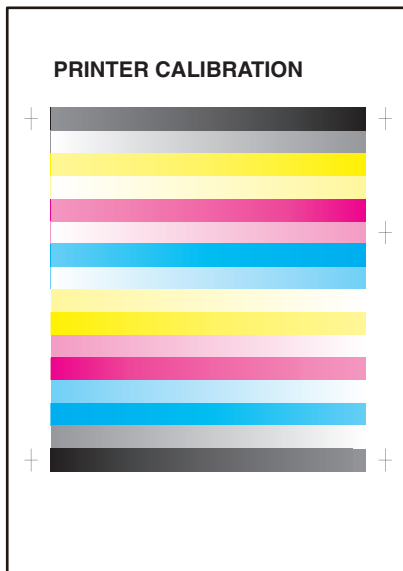

- 4) Select [FACTORY] key, and press [EXECUTE] key.

When the color balance is customized with the manual color balance adjustment (SIM 67-25) according to the user's request and the color balance is registered as the service target with SIM 67-27, if the color balance is adjusted to that color balance, select the service target.

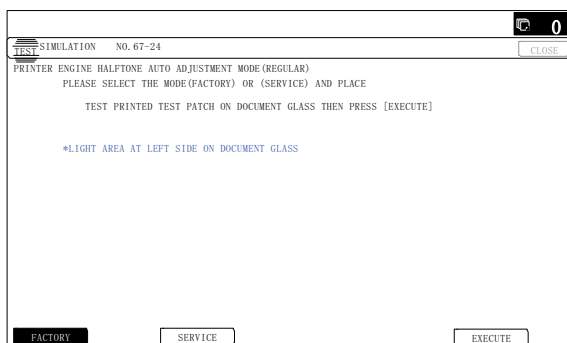

The copy color balance adjustment is automatically executed and prints the color balance check patch image. Wait until the operation panel shown in the procedure 5) is displayed.

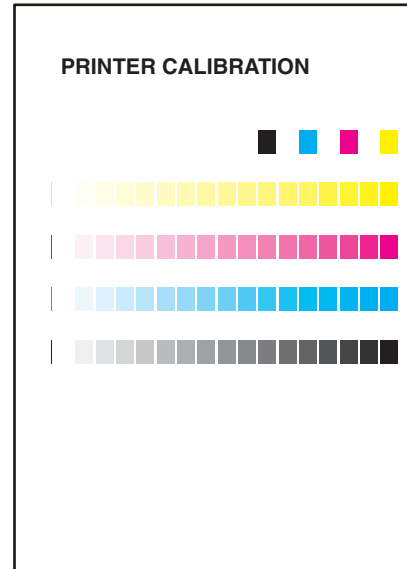

- 5) Press [OK] key on the operation panel.

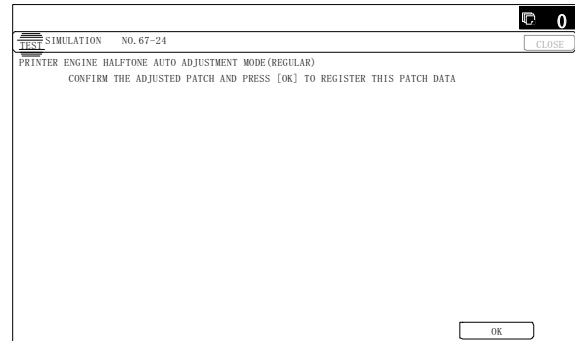

#### Note

After pressing [OK] key, the initial setting of the halftone image correction is started. During the operation, "NOW REGISTERING THE NEW TARGET OF HALFTONE" is displayed. This operation takes several minutes.

After completion of the operation, "PLEASE QUIT THIS MODE" is displayed.

Do not cancel the simulation until "PLEASE QUIT THIS MODE" is displayed.

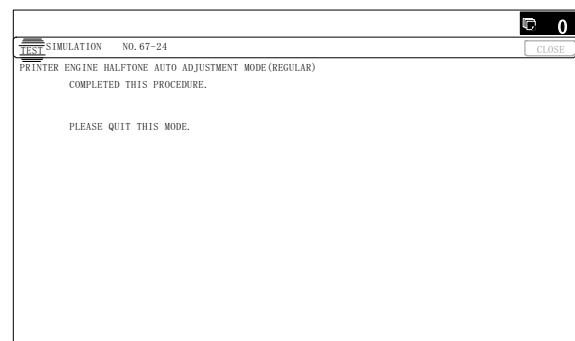

After completion of the operation, the simulation is canceled.

- 6) Check the color balance and density.  
(Refer to the item of the printer color balance and density check.)

When satisfactory color balance and density are not obtained from the automatic adjustment by selecting the factory target in procedure 4), change the factory color balance target with SIM 67-26 and repeat the procedures from 1).

If a satisfactory result on the color balance and the density is not obtained with the automatic adjustment, execute the manual adjustment (SIM 67-25) (ADJ 10E (2)).

Also when the service target is selected in procedure 4) to execute the automatic adjustment and a satisfactory result is not obtained, perform the manual color balance adjustment (ADJ 10E (2)).

If the color balance or density is not in the satisfactory level even after execution of the automatic and manual adjustments, there may be another cause.

Troubleshoot the cause, repair or perform necessary works, and repeat the adjustment from the beginning.

## 10-E (2) Printer color balance adjustment (Manual adjustment)

### a. General

The color balance adjustment (Manual adjustment) is used to adjust the printer density of C, M, Y and K. This is used at the following situation. When the result of auto adjustment described above is not existing within the range of reference. When a fine adjustment is required. When there is request from the user for changing (customizing) the color balance.

In this manual adjustment, adjust only the color patch which could not adjusted properly in the automatic adjustment.

If the color balance is improper, execute the automatic color balance adjustment in advance, and execute this adjustment for better efficiency.

### b. Adjustment procedure

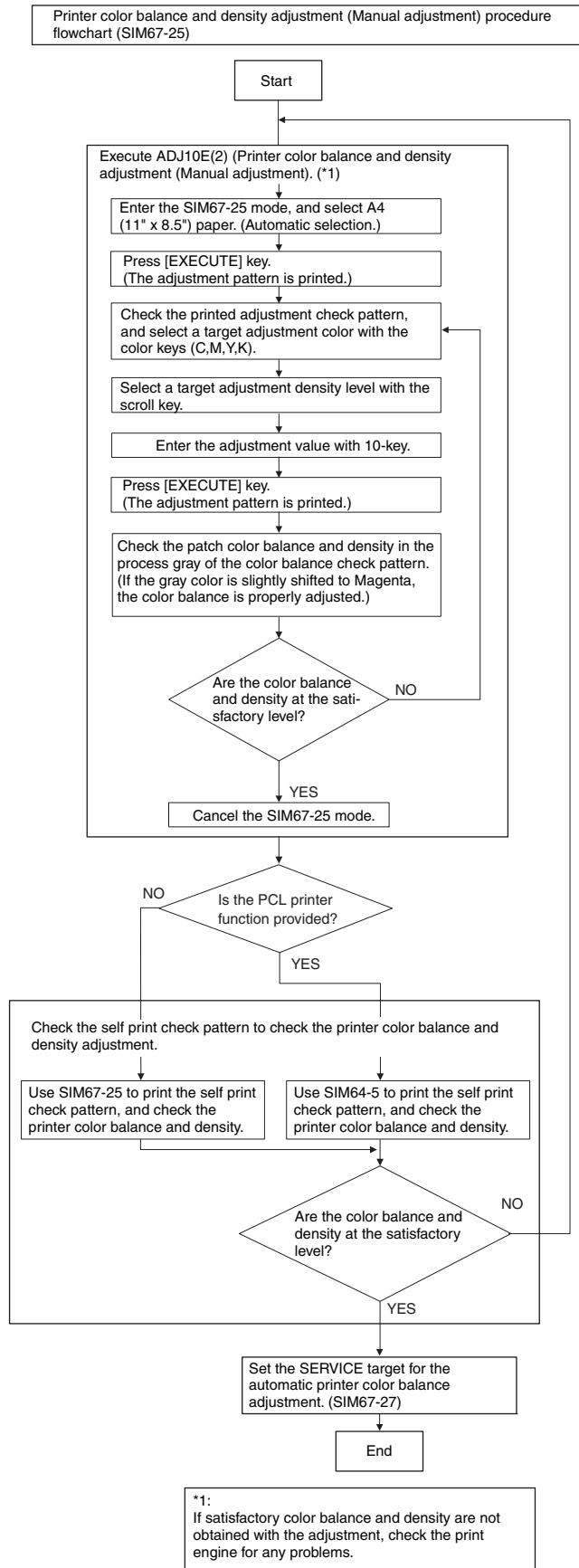

1) Enter the SIM 67-25 mode.

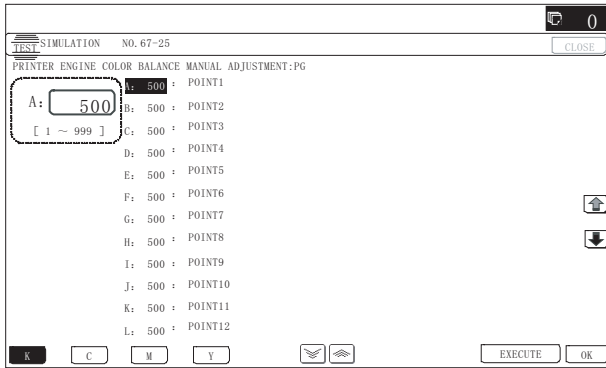

10-key  
OK

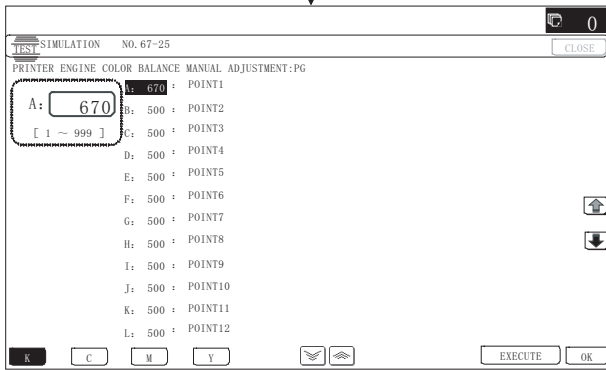

EXECUTE

EXECUTE

or end of print

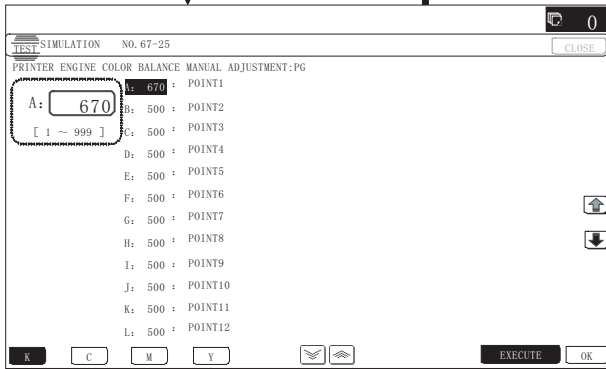

2) Press [EXECUTE] key. (A4/11" x 8.5" or A3/11" x 17" paper is automatically selected.)

The color balance adjustment pattern is printed.

3) Check that the following specification is satisfied or the color balance is satisfactory.

If not, execute the following procedures.

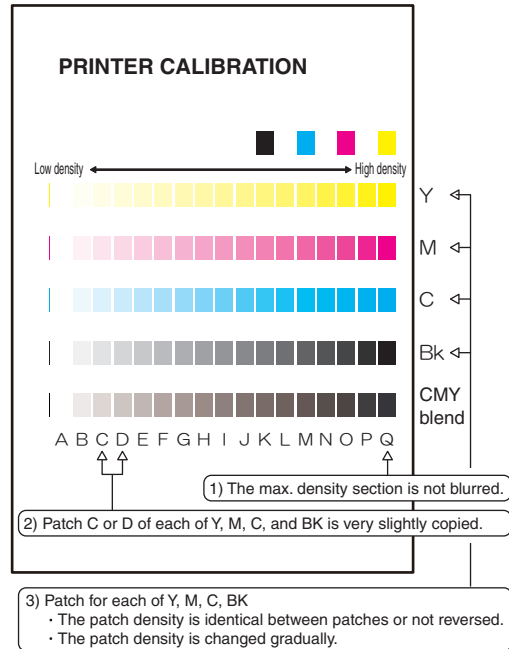

The print density must be changed gradually from the lighter level to the darker level. The density changing direction must not be reversed.

The density level of each color must be almost at the same level.

Patch B may not be copied.

Patch A must not be copied.

When, however, the color balance is adjusted according to a request from the user, there is no need to set to the standard color balance stated above.

If the color balance of each patch of the process black (CMY mixed color) is slightly shifted to Magenta, it means that the adjustment is proper. In an actual print mode, it is converted into the natural gray color balance by the color table. (When the color balance target is DEF 1.)

4) Select the color to be adjusted with the color select key, and select the adjustment point with the scroll key.

5) Enter the adjustment value with 10-key and press [OK] key.

The adjustment value is set in the range of (1 - 999). When SIM 67-24 is used to adjust the automatic color balance and density, all the set values of this simulation are set to 500.

To increase the density, increase the adjustment value. To decrease the density, decrease the adjustment value.

Repeat procedures of 2) - 5) until the condition of 3) is satisfied.

When the overall density is low, or when the density is high and patch A is copied, use the arrow key to adjust all the adjustment values of A - Q (MAX) to a same level collectively.

Then, adjust each patch density individually. This is an efficient way of adjustment.

Referring to the black/gray patches, adjust so that each process (CMY) black/gray patch color balance of A - Q (MAX) approaches the black/gray patch level as far as possible.

- 6) Check the color balance and density.  
(Refer to the item of the printer color balance and density check.)

**Note**

If the color balance is customized, use SIM 67-27 to register the color balance as the service target.

If the color balance is not customized, this procedure is not required.

If the customized color balance is registered as the service target, the automatic color balance adjustment can be made in the next color balance adjustment.

**10-F Printer image quality adjustment (Individual adjustment)**

**a. General**

This adjustment is used to execute the fine adjustment in each mode only when a satisfactory image quality is not obtained by the basic adjustments ADJ 10E (1) and ADJ 10E (2) or there is a request from the user. Normally there is no need to execute this adjustment.

This must be well understood for execution of the adjustment.

**10-F (1) Printer density adjustment (Low density section density adjustment) (No need to adjust normally)**

This adjustment is used to adjust the image density in the low density area in the printer mode.

Adjust to reproduction setting of the low density image.

This adjustment is required in the following cases.

- \* When it is required not to reproduce images in the low density section, or to reproduce low-density images.
- \* When there is request from the user.

- 1) Enter the SIM 67-36 mode.

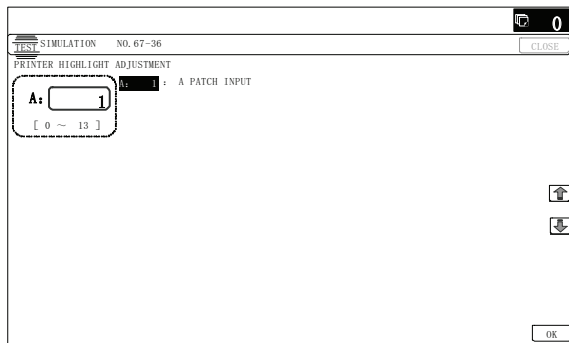

10-key

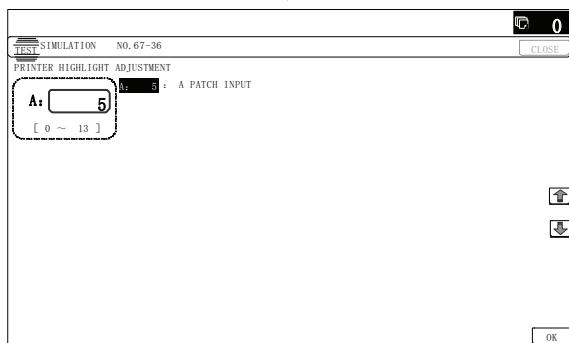

- 2) Enter the adjustment value and press the [OK] key.  
In case of increase of the image density on low density part, increase the adjustment value. For diluting the image density on low density part, decrease the adjustment value.

**10-F (2) Printer high density image density reproduction setting (Supporting the high density section tone gap) (No need to adjust normally)**

When a tone gap is generated in the high density section in the printer mode, the setting is changed to lower the density in the high density section.

This setting is normally not required, however, in the following cases, a change of setting must be made.

- \* When a tone gap occurs on part of high density.
- \* To lower the density in the high density section.

**a. Adjustment procedure**

- 1) Enter the SIM 67-34 mode.

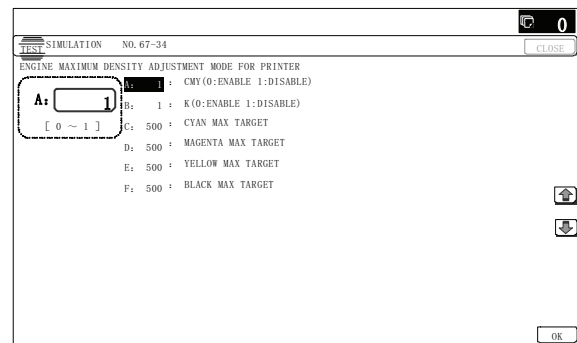

10-key

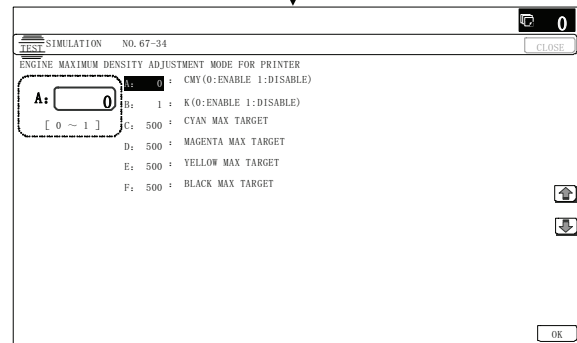

- 2) Select the item A, B with the scroll key.

Display/Item	Content	Setting range	Default	
A	CMY (0: ENABLE 1:DISABLE)	0	0 - 1	0
		1		
B	K (0:ENABLE 1: DISABLE)	0	0 - 1	1
		1		
C	CYAN MAX TARGET	Scanner target value for CYAN maximum density correction	0 - 999	500

Display/Item	Content	Setting range	Default
D	MAGENTA MAX TARGET	Scanner target value for MAGENTA maximum density correction	0 - 999 500
E	YELLOW MAX TARGET	Scanner target value for YELLOW maximum density correction	0 - 999 500
F	BLACK MAX TARGET	Scanner target value for BLACK maximum density correction	0 - 999 500

- \* If a tone gap occurs on part of high density, set 0 to item A and B. The density of high density part decreases. However, the tone gap is better.
- \* In case of more increase of the density on high density part, set 1 to item A and B. The tone gap may occur in high density part.

**Important**

If the setting values of item C, D, E and F are changed, density of the high density part is changed. When these values are changed, be sure to perform the printer color balance and density adjustment. (Automatic adjustment)

**10-F (3) Printer gamma adjustment for each dither (Automatic adjustment) (No need to adjust normally) (Except for GDI printers)**

**a. General**

This adjustment is used to adjust the color balance and the density in the monochrome mode, the heavy paper mode, and the gloss paper mode.

This simulation is used to improve image quality in these modes and images.

**b. Adjustment procedures**

- 1) Enter the SIM67-54 mode.
- 2) Press [EXECUTE] key. A4/11" x 8.5" or A3/11" x 17" paper is automatically selected. The color patch image (adjustment pattern) is printed out.
- 3) Set the color patch image (adjustment pattern) printed in the procedure 2) on the document table so that the thin lines on the printed color patch image (adjustment pattern) are on the left side. Place 5 sheets of white paper on the printed color patch image (adjustment pattern).

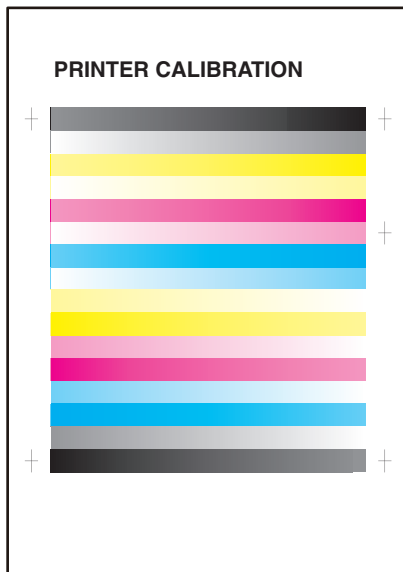

- 4) Press [EXECUTE] key. The color balance adjustment is automatically performed. The adjustment pattern is printed out. Check it for any abnormality.
- 5) Press [OK] key. The list of the adjustment items (for each dither) is displayed.
- 6) Select an adjustment item (for each dither).

Select item (Mode/Image)	Content
Heavy Paper	Adjustment item to improve the color balance in the heavy paper mode
B/W	Adjustment item to improve the density and gradation in the monochrome mode
Gloss Paper	Adjustment item to improve the color balance in the gloss paper mode
1200dpi 1bit*1	Adjustment item to improve the color balance in 1200dpi mode

\*1: 20cpm/23cpm/31cpm(G) machine: Disable

- 7) Press [EXECUTE] key. A4/11" x 8.5" or A3/11" x 17" paper is automatically selected. The color patch image (adjustment pattern) is printed out.
- 8) Set the color patch image (adjustment pattern) printed in the procedure 7) on the document table so that the thin lines on the printed color patch image (adjustment pattern) are on the left side. Place 5 sheets of white paper on the printed color patch image (adjustment pattern).

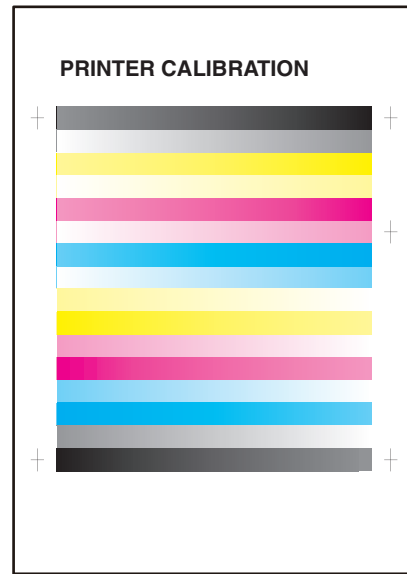

- 9) Press [EXECUTE] key. The color balance adjustment is automatically performed, and the machine goes to the state of procedure 6).
- 10) When [OK] key is pressed, the adjustment result is registered and the adjustment mode is terminated. When [EXECUTE] key is pressed, the adjustment result is registered and the screen is shifted to the other item (Mode/Image) select menu. To execute the adjustment of the other item (Mode/Image), press [EXECUTE] key. After completion of all the adjustments of the items (Mode/Image), press [OK] key, and the adjustment results are registered.
- 11) Make a print, and check the print image quality. (Refer to the item of the printer color balance and density check.)

**Note**

Use SIM67-52 to reset the adjustment values to the default values.

## 10-F (4)

### Automatic color balance adjustment by the user (Printer color balance automatic adjustment ENABLE setting and adjustment) (Normally unnecessary to the setting change)

#### a. General

In the user program mode, the user can execute the auto color calibration (auto adjustment of the printer color balance and density).

This adjustment is to set Enable/Disable of the above user operation with SIM 26-53.

#### Important

This setting must be set to ENABLE only when the user's understanding on the automatic adjustment of the copy color balance and density and the user's operational ability are judged enough to execute the adjustment.

When set to enable, operation procedures must be fully explained to the user.

#### b. Setting procedure

- 1) Enter the SIM 26-53 mode.

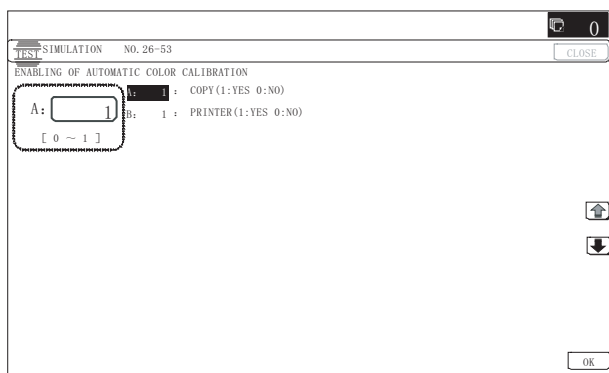

10-key

OK

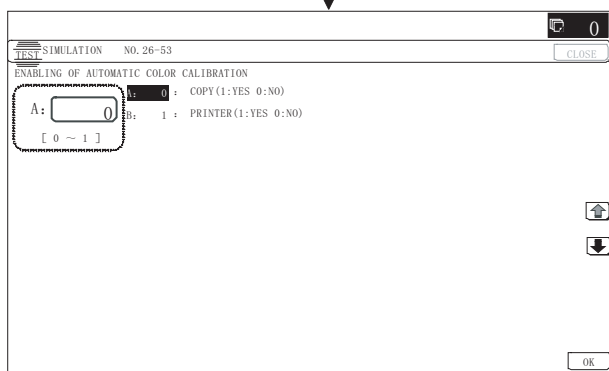

- 2) Select ENABLE or DISABLE with 10-key.  
When disabling, set to "0" (NO). When enabling, set to "1" (Yes).
- 3) Press [OK] key.

When set to DISABLE, the menu of the user auto color calibration (automatic adjustment of printer color balance and density) is not displayed in the user program mode.

### (Auto color calibration by the user (Auto color balance adjustment))

#### Important

This adjustment is based on the service target color balance set with SIM 67-27 or SIM 67-28. If, therefore, the above settings are not properly performed, this adjustment cannot be made properly.

- 1) Enter the system setting mode.
- 2) Enter the printer setting mode.
- 3) Press the auto color calibration key.
- 4) Press [EXECUTE] key.

The color patch image (adjustment pattern) is printed out.

- 5) Set the color patch image (adjustment pattern) printed in procedure 4) on the document table.

Set the patch image so that the thin line is on the left side as shown in the figure.

At that time, place 5 sheets of white paper on the above color patch image (adjustment pattern).

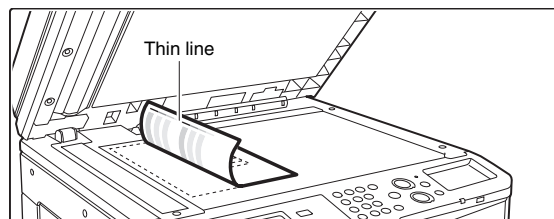

- 6) Press [EXECUTE] key, and the printer color balance adjustment is executed automatically.

For the 26cpm/36cpm/31cpm(A) machines, the message, "Will you go on to the copy color balance adjustment?" is displayed. To execute the copy color balance adjustment successively, perform the procedures same as the above.

## ADJ 11 Paper size sensor adjustment

### 11-A Manual paper feed tray paper size (width) sensor adjustment

This adjustment must be performed in the following cases:

- \* The manual paper feed tray section has been disassembled.
- \* The manual paper feed tray unit has been replaced.
- \* U2 trouble has occurred.
- \* The PCU PWB has been replaced.
- \* The EEPROM of the PCU PWB has been replaced.

1) Enter the SIM 40-2 mode.

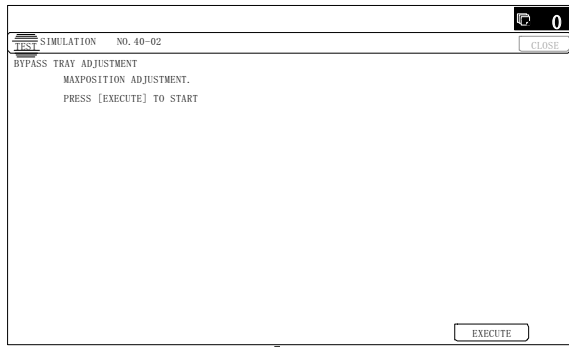

EXECUTE

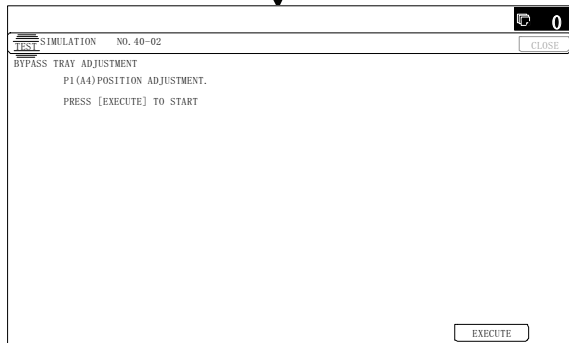
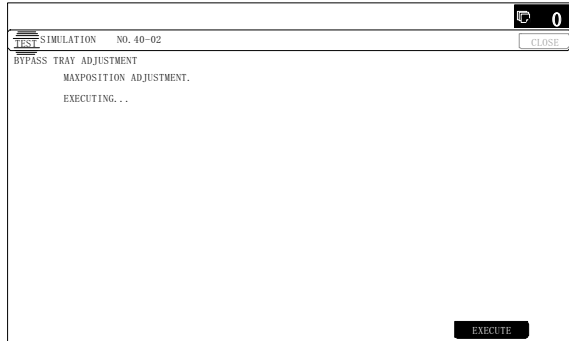

EXECUTE

Repeat the above procedure to adjust the A4R width MIN POSITION.

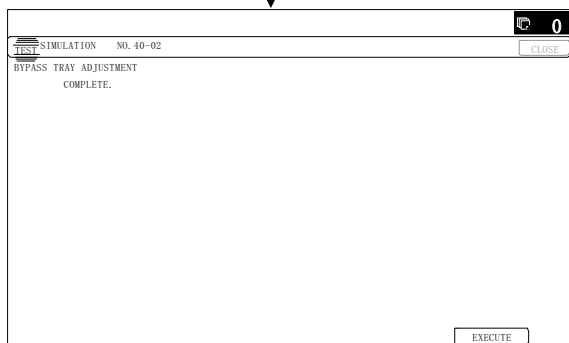

2) Open the manual paper feed guide to the maximum width position.

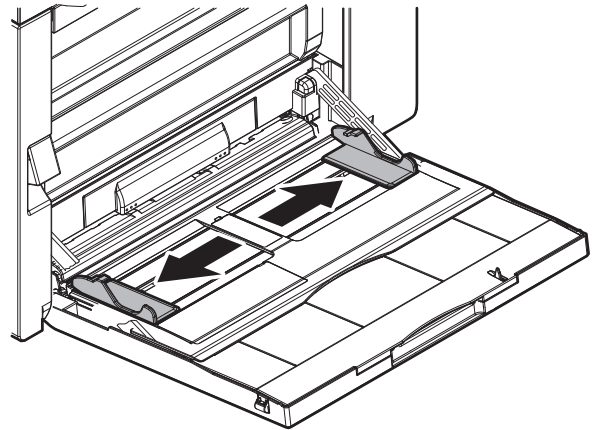

- 3) Press [EXECUTE] key.  
[EXECUTE] key is highlighted. Then it returns to the normal display.  
The maximum width position detection level of the manual paper feed guide is recognized.
- 4) Set the manual paper feed guide to the A4 size.
- 5) Press [EXECUTE] key.  
[EXECUTE] key is highlighted. Then it returns to the normal display.  
The A4 size width position detection level of the manual paper feed guide is recognized.
- 6) Set the manual paper feed guide to the width for the A4R size.
- 7) Press [EXECUTE] key.  
[EXECUTE] key is highlighted. Then it returns to the normal display.  
Set the manual paper feed guide to the width for the A4R size.
- 8) Open the manual paper feed guide to the minimum width position.
- 9) Press [EXECUTE] key.  
[EXECUTE] key is highlighted. Then it returns to the normal display.  
The minimum width position detection level of the manual paper feed guide is recognized.  
If the above operation is not completed normally, "ERROR" is displayed.  
When the operation is completed normally, the above data are saved to the memory and "COMPLETE" is displayed.

## 11-B RSPF paper feed tray document size (width) sensor adjustment

This adjustment must be performed in the following cases:

- \* The RSPF paper feed tray section has been disassembled.
- \* The RSPF paper feed tray unit has been replaced.
- \* When a U2 trouble occurs.
- \* The scanner PWB has been replaced.
- \* The EEPROM on the scanner PWB has been replaced.

1) Enter the SIM 53-6 mode.

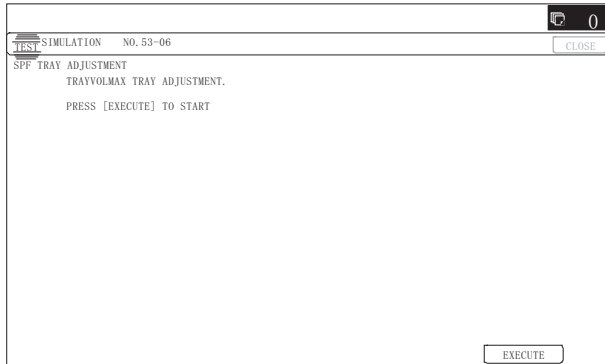

2) Open the RSPF paper feed guide to the maximum width position.

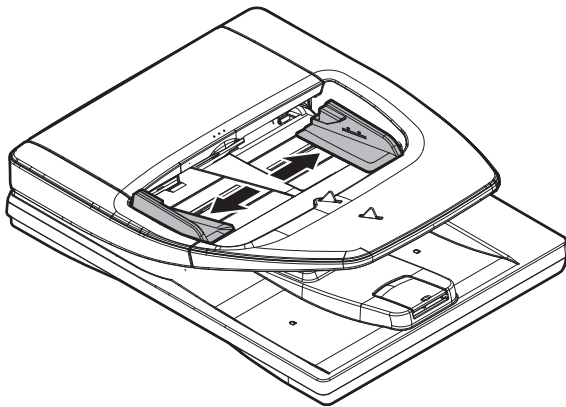

- 3) Press [EXECUTE] key.  
The maximum width detection level is recognized.
- 4) Open the RSPF paper feed guide to the width for the A4R size.
- 5) Press [EXECUTE] key.  
The A4R width detection level is recognized.
- 6) Open the RSPF paper feed guide to the width for the A5R size.
- 7) Press [EXECUTE] key.  
The A5R width detection level is recognized.
- 8) Open the RSPF paper feed guide to the minimum width position.
- 9) Press [EXECUTE] key.  
The minimum width detection level is recognized.

\* When each of the above operations has been completed, the "COMPLETE" message appears; when any of the operations has failed, the "ERROR" message appears.

## ADJ 12 Document size detection adjustment

This adjustment must be performed in the following cases:

- \* When the original size sensor section has been disassembled.
- \* When the original size sensor section has been replaced.
- \* When U2 trouble has occurred.
- \* When the scanner control PWB is replaced.
- \* When the EEPROM on the scanner control PWB is replaced.

### 12-A Document size sensor detection point adjustment

1) Enter the SIM 41-1 mode.

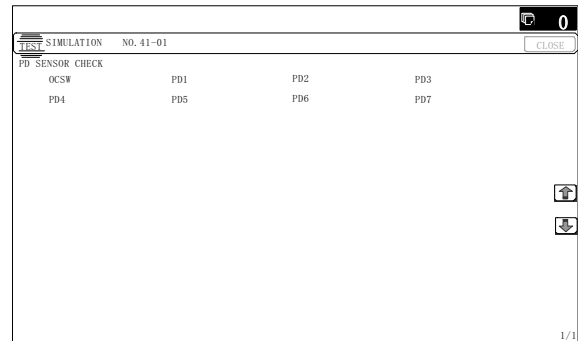

Loosen the original cover switch actuator adjustment screw and slide the actuator position so that the display OCSW is returned to the normal display when the height of the arm unit top from the table glass is  $20.2 \pm 0.25\text{mm}$  by slowly tilting the document detection arm unit in the arrow direction and adjust. (If the ON timing of the original cover switch is shifted, the document detection function may malfunction.)

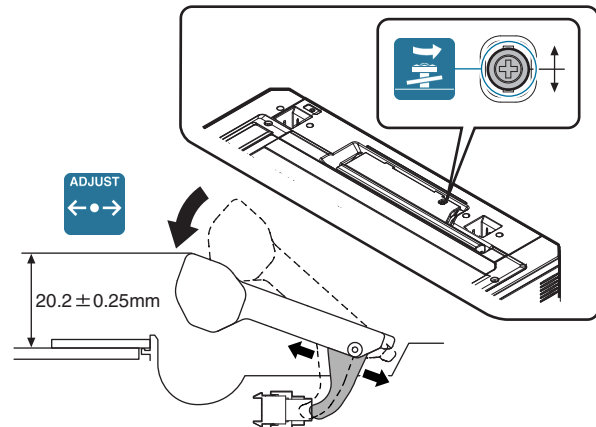



## 12-B Adjust the sensitivity of the original size sensor

- 1) Enter the SIM41-2 mode.

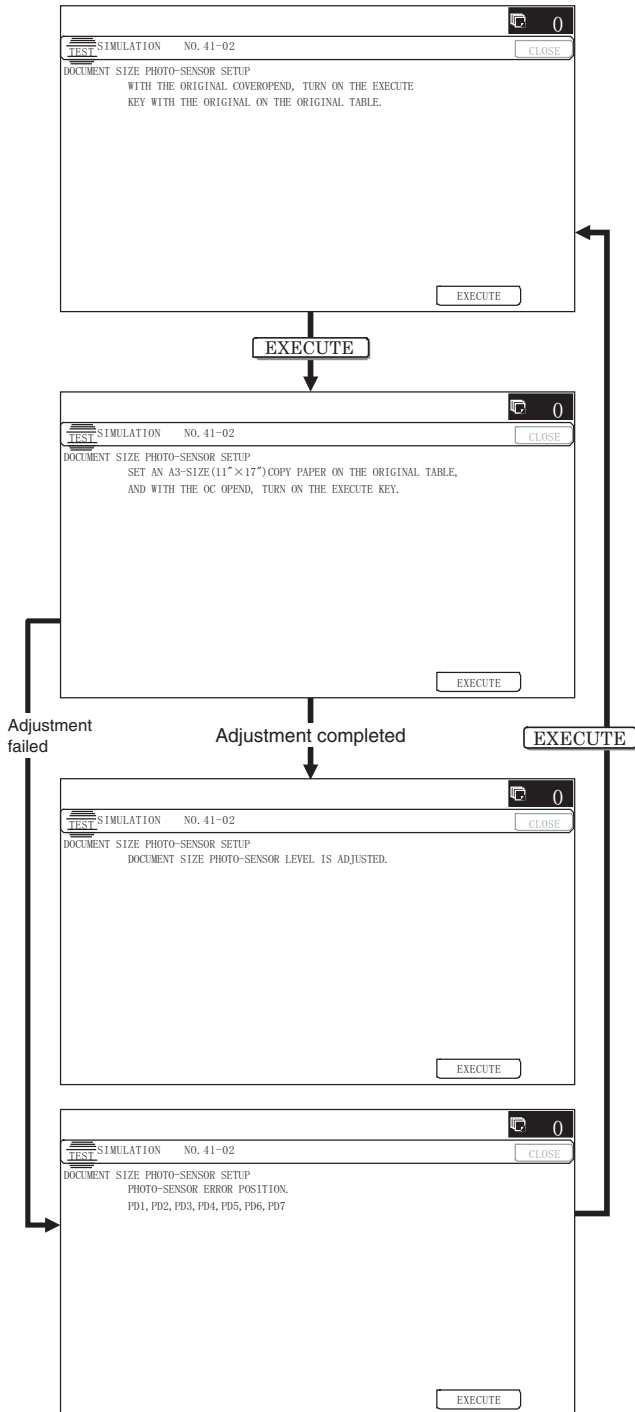

- 2) Execute the sensor adjustment without document.  
With the document cover open, without placing a document on the table glass, press [EXECUTE] key.
- 3) Place A3 (11" x 17") paper on the document table and press [EXECUTE] key.

If the adjustment is completed normally, "DOCUMENT SIZE PHOTO SENSOR LEVEL IS ADJUSTED" is displayed.

## ADJ 13 Touch panel coordinate setting

This adjustment must be performed in the following cases:

- \* The operation panel has been replaced.
- \* U2 trouble has occurred.
- \* The scanner control PWB has been replaced.
- \* The EEPROM on the scanner control PWB has been replaced.

- 1) Enter the SIM 65-1 mode.



- 2) Precisely press the cross mark points (4 positions).

When the cross mark is pressed precisely, a buzzer sounds and the display is reversed. When all the four points are pressed and the touch panel adjustment is completed, the display returns to the simulation sub number entry screen.

In case of an error, the display returns to the entry screen again.

Check to confirm that there is no shift between the display frame and the detection position when the touch panel is pressed.

- \* When pressing the touch panel, never use a sharp tip (such as a needle or a pin).

## ADJ 14 Fusing paper guide position adjustment

Normally there is no need to perform this adjustment. In the following cases, perform this adjustment.

- \* When a paper jam occurs in the fusing section.
- \* When wrinkles are made on paper in the fusing section.
- \* When an image deflection or an image blur is generated in the paper rear edge section.

- 1) Loosen the fusing paper guide fixing screws on the two positions in the front/rear frame direction.
- 2) Use the fusing paper guide position scale as the reference to shift the paper guide in the arrow direction A or B.

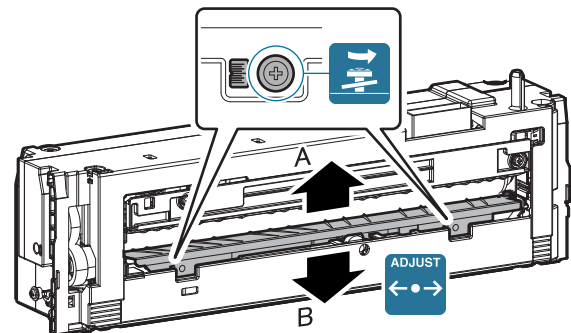

The standard fixing position is at two scales in direction B from the marking scale center. However, the position may be varied depending on the situation.

- \* When a wrinkle is made on paper, change the position in the error direction A.
- \* When an image deflection or unclear image is generated in the lead edge area of paper, change the position in the arrow direction B.

## ADJ 15 Print image position, image magnification ratio, void area, off-center adjustment (Print engine) (Manual adjustment)

### Note

Normally if the adjustment is executed by ADJ 4 (automatic adjustment), there is no need to execute this adjustment.

Only when the manual adjustment is required, execute this adjustment.

In other words, this manual adjustment is executed when a satisfactory result is not obtained from the automatic adjustment (ADJ 4).

### 15-A Print image magnification ratio adjustment (main scanning direction) (Print engine) (Manual adjustment)

This adjustment must be performed in the following cases:

- \* When the LSU (writing) unit is replaced.
- \* U2 trouble has occurred.
- \* The PCU PWB has been replaced.
- \* The EEPROM of the PCU PWB has been replaced.

- 1) Enter the SIM 50-10 mode.

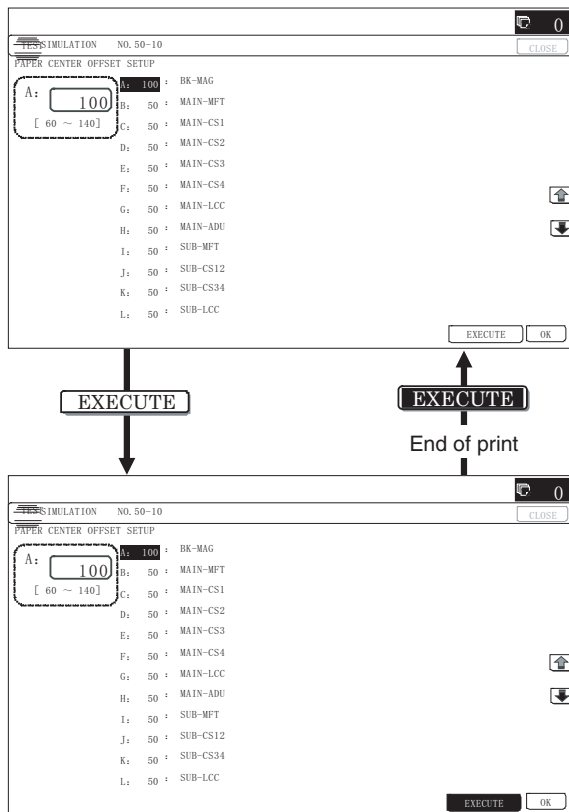

- 2) Set A4 (11" x 8.5") paper in the paper feed tray.
- 3) Select the paper feed tray set in procedure 2) with the scroll key.
- 4) Press [EXECUTE] key.  
The check pattern is printed out.

- 5) Check that the inside dimension of the printed halftone is  $240 \pm 0.5\text{mm}$ .

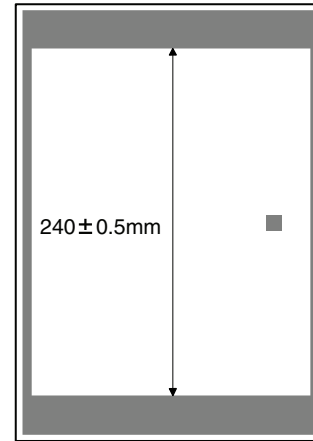

If the above requirement is not met, do the following steps.

- 6) Change the set value of set item A.  
When the set value is changed by 1, the dimension is changed by 0.1mm.

When the set value is increased, the BK image magnification ratio in the main scanning direction is increased. When the set value is decreased, the BK image magnification ratio in the main scanning direction is decreased.

Repeat procedures 2) - 6) until a satisfactory result is obtained.

### 15-B Print image print area adjustment (Print engine) (Manual adjustment)

This adjustment must be performed in the following cases:

- \* When the LSU is replaced or removed.
- \* When a paper tray is replaced.
- \* When the paper tray section is disassembled.
- \* When the manual feed tray is replaced.
- \* When the manual feed tray is disassembled.
- \* When the duplex mode paper transport section is disassembled.
- \* When the registration roller section is disassembled.
- \* U2 trouble has occurred.
- \* The PCU PWB has been replaced.
- \* The EEPROM of the PCU PWB has been replaced.

### Note

Before execution of this adjustment, be sure to execute the print image magnification ratio adjustment (ADJ 15A) (main scanning direction) (print engine) (manual adjustment).

- 1) Enter the SIM 50-10 mode.

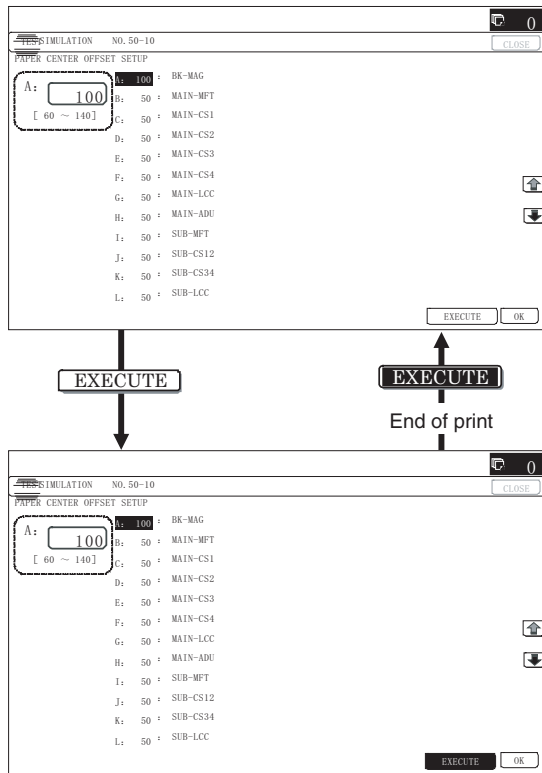

- 2) Set A4 (11 x 8.5") paper to all the paper feed trays. Select an adjustment item of the target paper feed tray among items B - N and enter the adjustment value. Then select item "O" to select the paper feed tray which is to be used for executing test printing.
- 3) Press [EXECUTE] key.  
The adjustment pattern is printed.
- 4) Check the adjustment pattern to confirm that the items below are in the range of the standard values.

	Content	Standard adjustment value
X	Lead edge void area	$4.0 \pm 1.0\text{mm}$
Y	Rear edge void area	$2.0 - 5.0\text{mm}$
Z1/Z2	FRONT/REAR void area	$2.0 \pm 2.0\text{mm}$

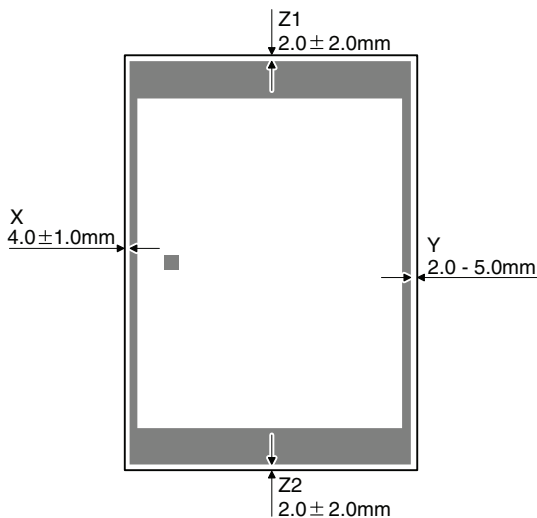

If the above condition is not satisfied, or if it is set to a desired condition, execute the simulation 50-1.

**Note**

Feed paper from all the paper feed trays to confirm.

- 5) Enter the SIM 50-1 mode.

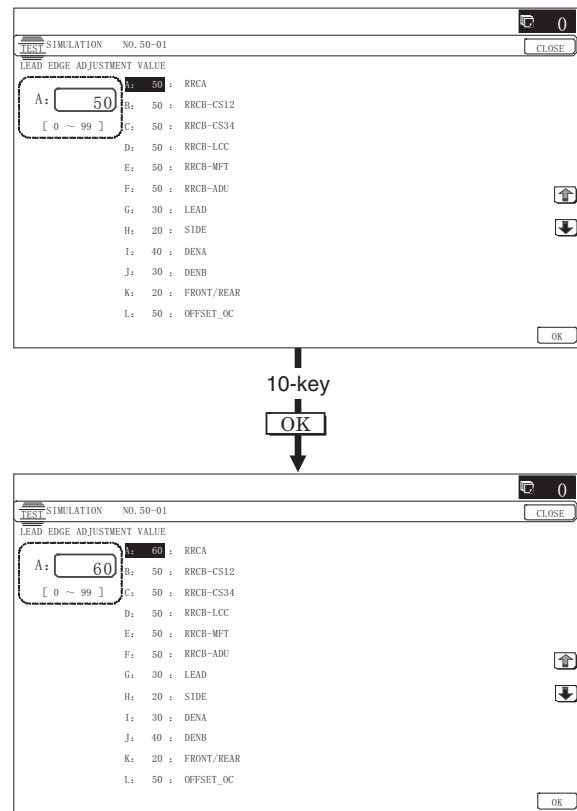

- 6) Select an adjustment item (DENA, DENB, FRONT/REAR) with the scroll key, enter the adjustment value, and press [OK] key.

Item/Display		Content	Setting range	Default value
Void area adjustment	DENA	Lead edge void area adjustment	1 - 99	40
	DENB	Rear edge void area adjustment	1 - 99	30
	FRONT/REAR	FRONT/REAR void area adjustment	1 - 99	20
Sub scanning direction print area correction value	DENB-MFT	Manual feed correction value	1 - 99	50
	DENB-CS1	Tray 1 correction value	1 - 99	50
	DENB-CS2	Tray 2 correction value	1 - 99	50
	DENB-CS3	Tray 3 correction value	1 - 99	50
	DENB-CS4	Tray 4 correction value	1 - 99	50
	DENB-LCC	LCC correction value	1 - 99	50
	DENB-ADU	ADU correction value	1 - 99	50
	DENB-HV	Heavy paper correction value	1 - 99	50

When the adjustment value is increased, the void area is increased. When the adjustment value is decreased, the void area is decreased.

When the adjustment value is changed by 1, the void area is changed by 0.1mm.

**Note**

The adjustment value and the actual void area are related as follows:

$$\text{Adjustment value}/10 = \text{Actual void area}$$

**Note**

When the amount of the rear edge void is different between each paper feed tray, change the adjustment value of item (DENB-XXX) in SIM50-1 and adjust.

The adjustment item (DENB) have a effect on the paper of all paper feed tray.

That is, adjustment value of item (DENB-XXX) fine adjusts to adjustment item (DENB) for each paper tray.

After execution of the above, perform procedures 1) - 4) to check that the void area is within the specified range.

Though the lead edge void area adjustment value is proper, if the lead edge void area is not within the specified range, change the adjustment value of item (RRCB-XXX) in SIM 50-1.

Repeat the above procedures until a satisfactory result is obtained.

### 15-C Print image off-center adjustment (Print engine) (Manual adjustment)

This adjustment must be performed in the following cases:

- \* When the LSU is replaced or removed.
- \* When a paper tray is replaced.
- \* When the paper tray section is disassembled.
- \* When ADJ 3B Print engine image magnification ratio adjustment (Main scanning direction) is performed.
- \* When the manual feed tray is replaced.
- \* When the manual feed tray is disassembled.
- \* When the duplex mode paper transport section is disassembled.
- \* When the registration roller section is disassembled.
- \* U2 trouble has occurred.
- \* The PCU PWB has been replaced.
- \* The EEPROM of the PCU PWB has been replaced.

#### Note

Before execution of this adjustment, check to insure the following item.

- \* The print image magnification ration adjustment (ADJ 15A) (main scanning direction) (Print engine) (Manual adjustment) has been properly adjusted.

- 1) Enter SIM 50-10 mode.

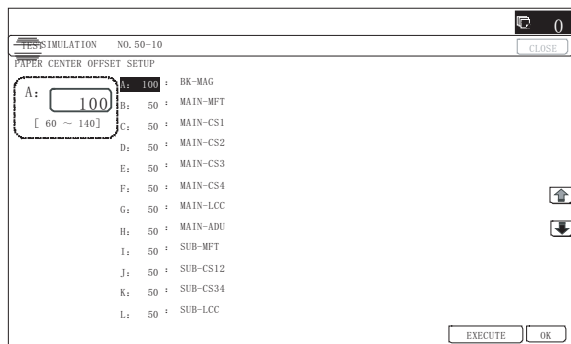

EXECUTE

EXECUTE

End of print

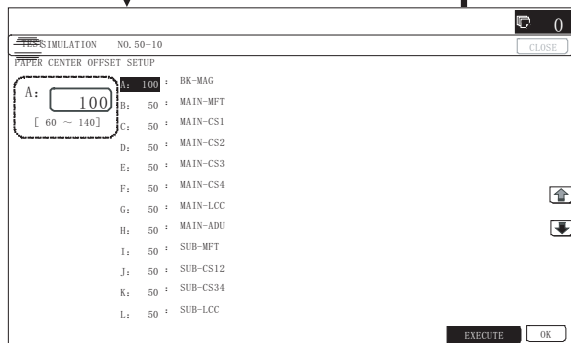

- 2) Select the target paper feed tray (MAIN-XX) with the scroll key.

Display/Item	Content	Setting range
NO	Not select	1

- 3) Set A4 (11" x 8.5") paper in the paper feed tray selected in procedure 2).
- 4) Press [EXECUTE] key.  
The adjustment pattern is printed.
- 5) Check that the adjustment pattern image is printed in the correct position.

Measure the dimension of the void area in the front and the rear frame direction of the adjustment pattern, and check that all the following conditions are satisfied.

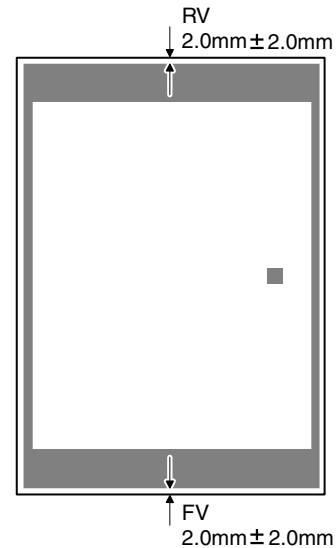

RV: REAR VOID AREA  
FV: FRONT VOID AREA

$$RV + FV \leq 4.0\text{mm}$$

$$RV = 2.0 \pm 2.0\text{mm}$$

$$FV = 2.0 \pm 2.0\text{mm}$$

If the above requirement is not met, do the following steps.

- 6) Change the adjustment value.  
Enter the adjustment value and press the [OK] key or the [EXECUTE] key.

When [EXECUTE] key is pressed, the adjustment pattern is printed.

When the adjustment value is increased, the adjustment pattern is shifted to the front frame side. When it is decreased, the adjustment pattern is shifted to the rear frame side.

When the set value is changed by 1, the shift distance is changed by about 0.1mm.

Repeat procedures 3) - 6) until the conditions of procedure 5) are satisfied.

In case a satisfactory result cannot be obtained by repeating the above procedures, perform the following procedure.

- 7) Loosen the paper feed tray off-center adjustment screws (2 pcs.) at the center section of the lift plate of the paper feed tray, and change the gear unit position in the front/rear frame direction. Repeat the adjustment procedures from 4).

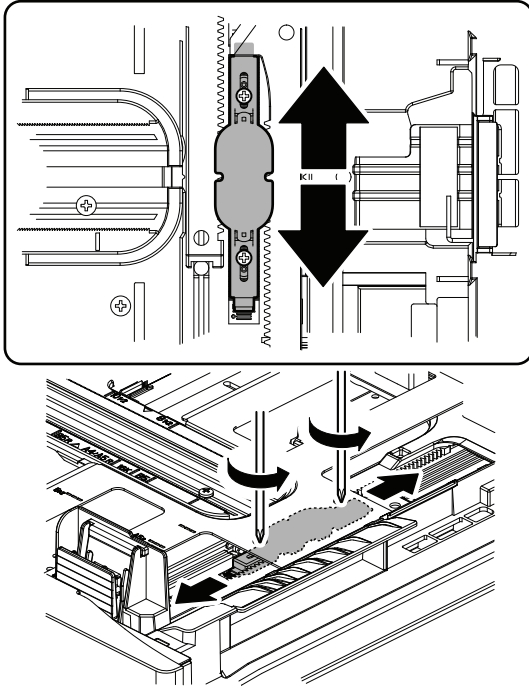

**Note**

Normally if the adjustment is executed by ADJ 4 (automatic adjustment), there is no need to execute this adjustment.

Only when the manual adjustment is required, execute this adjustment.

In other words, this manual adjustment is executed when a satisfactory result is not obtained from the automatic adjustment (ADJ 4).

**ADJ 16 Scan image magnification ratio adjustment (Manual adjustment)**

**Note**

Normally if the adjustment is executed by ADJ 4 (automatic adjustment), there is no need to execute this adjustment.

Only when the manual adjustment is required, execute this adjustment.

In other words, this manual adjustment is executed when a satisfactory result is not obtained from the automatic adjustment (ADJ 4).

**16-A Scan image magnification ratio adjustment (main scanning direction) (Manual adjustment) (Document table mode)**

**Important**

If the default adjustment value of the scan image magnification ratio adjustment (main scanning direction) of SIM 48-1, copy image quality may be degraded. Therefore, this adjustment must be executed only when there is a special necessity.

This adjustment must be performed in the following cases:

- \* When the copy magnification ratio in the copy image main scanning direction is not properly adjusted.
- \* When the scanner motor is replaced.
- \* U2 trouble has occurred.
- \* When the scanner control PWB is replaced.
- \* When the EEPROM of the scanner control PWB is replaced.

Before this adjustment, the focus adjustment (CCD unit installing position adjustment) must have been completed.

- 1) Place a scale on the document table as shown in the figure below.

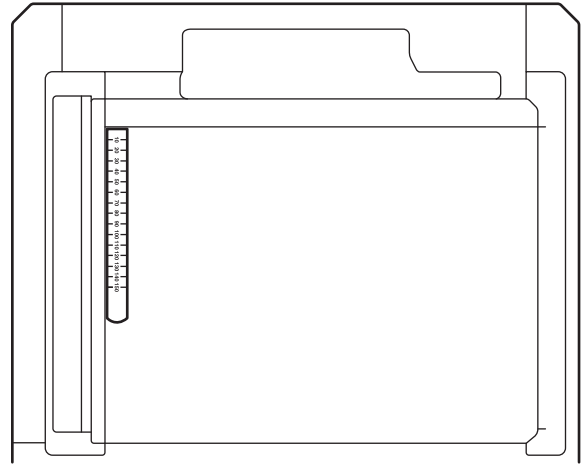

- 2) Enter the SIM 48-1 mode.

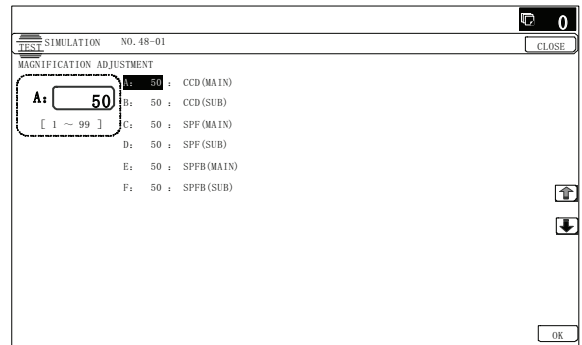

- 3) Make a normal copy and obtain the copy magnification ratio. Press [CLOSE] key to shift from the simulation mode to the copy mode, and make a copy.
- 4) Check that the copy magnification ratio is within the specified range ( $100 \pm 1.0\%$ ).  
If the copy magnification ratio is within the specified range ( $100 \pm 1.0\%$ ), the adjustment is completed. If the copy magnification ratio is not within the specified range, perform the following procedure.
- 5) Change the CCD (MAIN) adjustment value of Simulation 48-1. When the adjustment value is increased, the copy magnification ratio is increased. When the adjustment value is changed by 1, the copy magnification ratio is changed by about 0.02%. Repeat the procedures 3) - 5) until the copy magnification ratio is within the specified range ( $100 \pm 1.0\%$ ).

## 16-B Scan image magnification ratio adjustment (sub scanning direction) (Manual adjustment) (Document table mode)

This adjustment must be performed in the following cases:

- \* When the copy magnification ratio in the copy image sub scanning direction is not properly adjusted.
- \* When the scanner motor is replaced.
- \* U2 trouble has occurred.
- \* When the scanner control PWB is replaced.
- \* When the EEPROM of the scanner control PWB is replaced.

- 1) Place a scale on the document table as shown in the figure below.

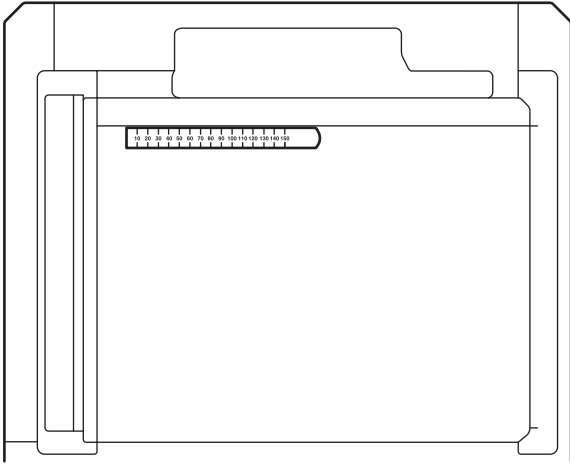

- 2) Enter the SIM 48-1 mode.

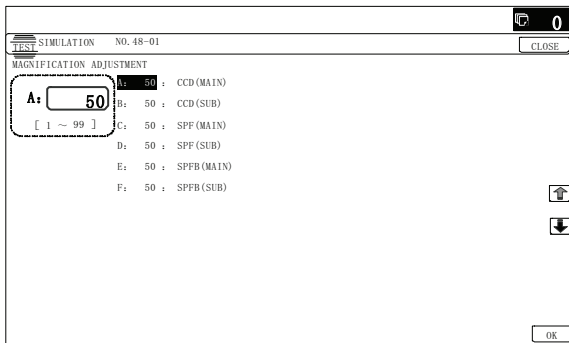

- 3) Make a normal copy and obtain the copy magnification ratio. Go to the copy mode, and make a copy.

$$\text{Copy magnification ratio} = \frac{(\text{Original dimension} - \text{Copy dimension})}{\text{Original dimension}} \times 100\%$$

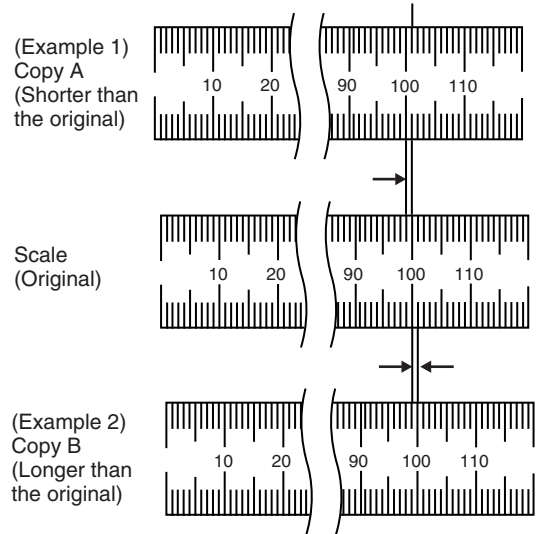

- 4) Check that the copy magnification ratio is within the specified range ( $100 \pm 1.0\%$ ).

If the copy magnification ratio is within the specified range ( $100 \pm 1.0\%$ ), the adjustment is completed. If the copy magnification ratio is not within the specified range, perform the following procedure.

- 5) Change the CCD (SUB) adjustment value of Simulation 48-1. When the adjustment value is increased, the copy magnification ratio in the sub scanning direction is increased. When the adjustment value is changed by 1, the copy magnification ratio is changed by about 0.1%.

Repeat the procedures 3) - 5) until the copy magnification ratio is within the specified range ( $100 \pm 1.0\%$ ).

## 16-C Scan image magnification ratio adjustment (main scanning direction) (Manual adjustment) (RSPF mode)

This adjustment must be performed in the following cases:

- \* When the scan control PWB is replaced.
- \* When the EEPROM on the scan control PWB is replaced.
- \* When U2 trouble occurs.
- \* When the copy magnification ratio of the RSPF mode copy image in the main scanning direction is not proper.
- \* When the RSPF is disassembled.

### a. Adjustment procedures

- 1) Place the duplex adjustment chart shown below on the document tray of the RSPF.

The adjustment chart is prepared by the following procedures.  
Use A4 (11" x 8.5") paper, and put marks on both sides and both surfaces of the paper at 10mm from each edge.

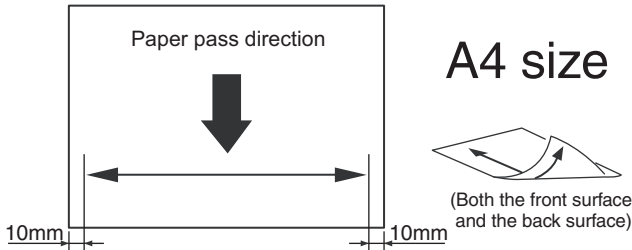

- 2) Make a duplex copy at the normal ratio on A4 paper.
- 3) Measure the images on the copy paper and the original images.

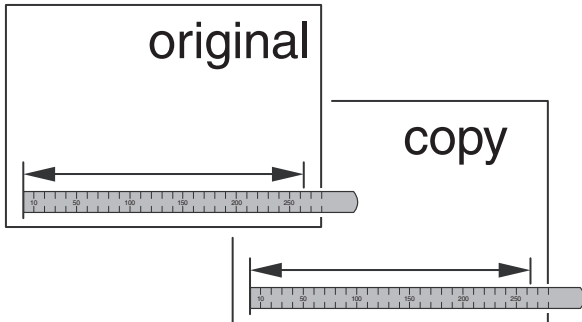

- 4) Obtain the image magnification ratio according to the following formula:

Image magnification ratio = Original size / Original size x 100 (%)

Image magnification ratio = 99 / 100 x 100 = 99 (%)

If the image magnification ratio is within the specified range (100 ± 0.8%), there is no need to perform the adjustment.

If it is not within the specified range, perform the following procedures.

- 5) Enter the SIM 48-1 mode.

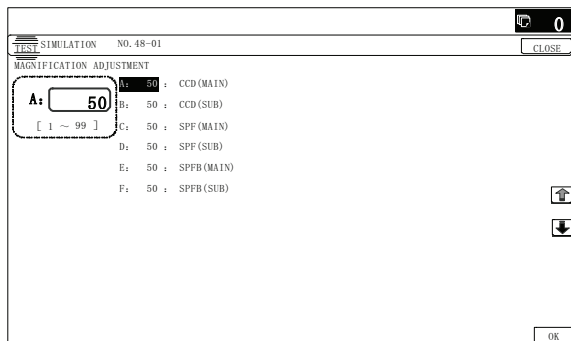

## RSPF

Item	Display	Content	Setting range	Default value
A	CCD(MAIN)	SCAN main scanning magnification ratio adjustment (CCD)	1 - 99	50
B	CCD(SUB)	SCAN sub scanning magnification ratio adjustment (CCD)	1 - 99	50
C	SPF(MAIN)	RSPF document front surface magnification ratio adjustment (Main scan)	1 - 99	50
D	SPF(SUB)	RSPF document front surface magnification ratio adjustment (Sub scan)	1 - 99	50
E	SPFB(MAIN)	RSPF document back surface magnification ratio adjustment (Main scan)	1 - 99	50
F	SPFB(SUB)	RSPF document back surface magnification ratio adjustment (Sub scan)	1 - 99	50

- 6) Select an adjustment item of SPF (MAIN)/SPFB (MAIN) with the scroll key.

SPF (MAIN) Main scanning direction image magnification ratio (Front surface)

SPFB (MAIN) Main scanning direction image magnification ratio (Back surface)

- 7) Enter an adjustment value with 10-key, and press [OK] key.  
When the adjustment value is increased, the image magnification ratio is increased. When the adjustment value is changed by 1, the image magnification ratio is changed by 0.02%.

- 8) Make a normal copy and obtain the copy magnification ratio.

Repeat the procedures of 1) - 8) until a satisfactory result is obtained.

## 16-D Scan image magnification ratio adjustment (sub scanning direction) (Manual adjustment) (RSPF mode)

This adjustment must be performed in the following cases:

- \* When the SCAN CONTROL PWB is replaced.
- \* When the EEPROM on the SCAN CONTROL PWB is replaced.
- \* When U2 trouble occurs.
- \* When the copy magnification ratio of the RSPF mode copy image in the sub scanning direction is not proper.
- \* When the RSPF is disassembled.

- 1) Place the duplex adjustment chart shown below on the document tray of the RSPF.

The adjustment chart is prepared by the following procedures.  
Use A4 (11" x 8.5") paper, and put marks on both sides and both surfaces of the paper at 10mm from each edge.

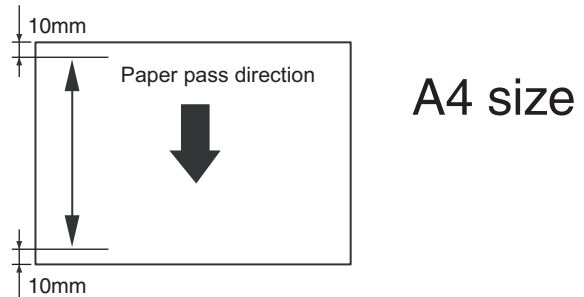

- 2) Make a duplex copy at the normal ratio on A4 paper.
- 3) Measure the images on the copy paper and the original images.

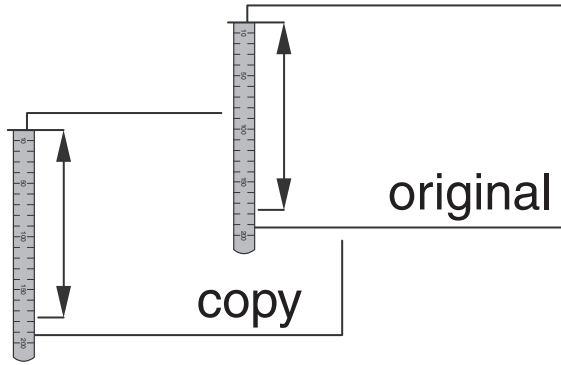

- 4) Obtain the image magnification ratio according to the following formula:  
 Image magnification ratio = Original size / Original size x 100 (%)  
 Image magnification ratio = 99 / 100 x 100 = 99 (%)  
 If the image magnification ratio is within the specified range (100 ± 0.8%), there is no need to perform the adjustment.  
 If it is not within the specified range, perform the following procedures.
- 5) Enter the SIM 48-1 mode.

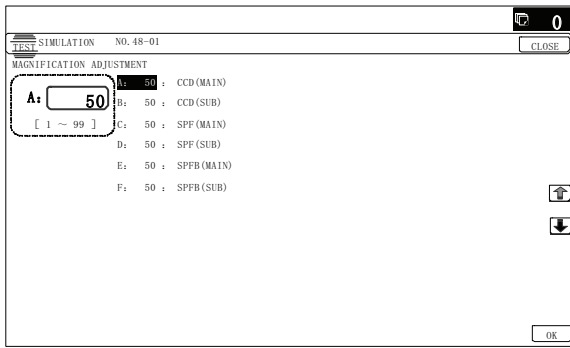

Item	Display	Content	Setting range	Default value
A	CCD(MAIN)	SCAN main scanning magnification ratio adjustment (CCD)	1 - 99	50
B	CCD(SUB)	SCAN sub scanning magnification ratio adjustment (CCD)	1 - 99	50
C	SPF(MAIN)	RSPF document front surface magnification ratio adjustment (Main scan)	1 - 99	50
D	SPF(SUB)	RSPF document front surface magnification ratio adjustment (Sub scan)	1 - 99	50
E	SPFB(MAIN)	RSPF document back surface magnification ratio adjustment (Main scan)	1 - 99	50
F	SPFB(SUB)	RSPF document back surface magnification ratio adjustment (Sub scan)	1 - 99	50

- 6) Select an adjustment item with the scroll key.  
 SPF (SUB) Sub scanning direction image magnification ratio (Front surface)  
 SPFB (SUB) Sub scanning direction image magnification ratio (Back surface)

- 7) Enter an image magnification ratio adjustment value with 10-key, and press [OK] key.  
 When the adjustment value is increased, the image magnification ratio is increased.  
 When the adjustment value is changed by 1, the image magnification ratio is changed by 0.1%.
- 8) Make a normal copy and obtain the copy magnification ratio.  
 Repeat the procedures of 1) - 8) until a satisfactory result is obtained.

## ADJ 17 Scan image off-center adjustment (Manual adjustment)

### Note

Normally if the adjustment is executed by ADJ 4 (automatic adjustment), there is no need to execute this adjustment. Only when the manual adjustment is required, execute this adjustment. In other words, this manual adjustment is executed when a satisfactory result is not obtained from the automatic adjustment (ADJ 4).

### 17-A Scan image off-center adjustment (Manual adjustment) (Document table mode)

This adjustment must be performed in the following cases:

- \* When the scanner (reading) section is disassembled.
  - \* When the scanner (reading) unit is replaced.
  - \* When a U2 trouble occurs.
  - \* When the scanner control PWB is replaced.
  - \* When the EEPROM on the scanner control PWB is replaced.
- 1) Make a copy of the adjustment chart (made by yourself) in the adjustment mode (document table).

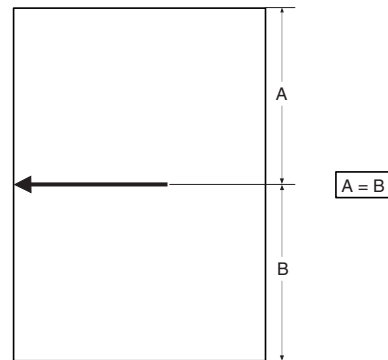

- 2) Check the copy image center position.  
 If  $A - B = \pm 1.0\text{mm}$ , the adjustment is not required.

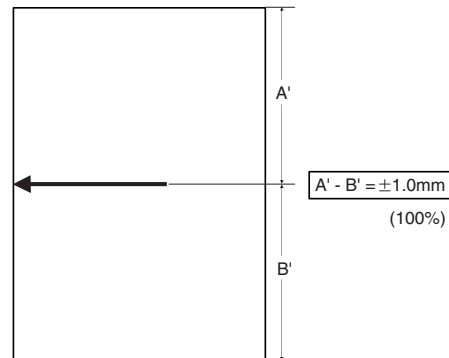

If the above condition is not satisfied, perform the following procedures.



- 3) Enter the SIM 50-12 mode.

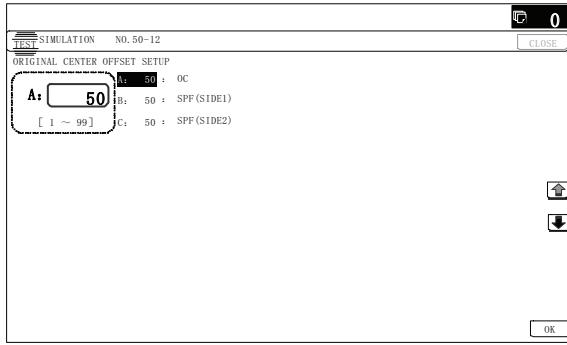

- 4) Select the adjustment mode OC with the scroll key.
  - 5) Enter the adjustment value with 10-key, and press [OK] key. The entered value is set. When the set value is increased, the main scanning print position is shifted to the front side by 0.1mm.
  - 6) Go to the copy mode, and make a copy.
- Repeat the procedures of 1) - 6) until the above condition is satisfied.

### 17-B Scan image off-center adjustment (Manual adjustment) (RSPF mode)

This adjustment must be performed in the following cases:

- \* When the scan control PWB is replaced.
- \* When the EEPROM on the scan control PWB is replaced.
- \* When the scanner (reading) section is disassembled.
- \* When the scanner (reading) section is replaced.
- \* When U2 trouble occurs.
- \* When the RSPF section is disassembled.
- \* When the RSPF unit is replaced.

#### Important

To execute this adjustment, it is required that the ADJ 17A Scan image off-center adjustment (Document table mode) must have been properly adjusted.

- 1) Prepare the adjustment chart.

Draw a line at the center of the front surface and the back surface of A4 (11" x 8.5") paper in parallel with the paper transport direction.

← Paper transport direction

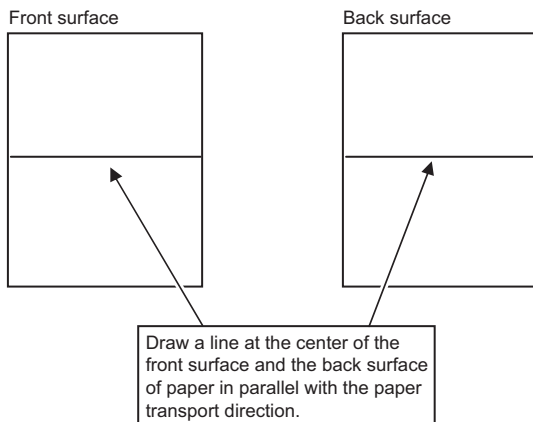

- 2) Set the adjustment chart to the RSPF.
- 3) Make a duplex copy in the normal magnification ratio from the manual paper feed tray, and check the image position on the front surface and the back surface of the copy paper.

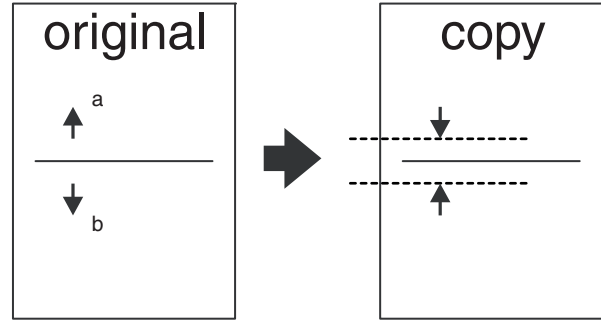

If the difference is within the range of  $0 \pm 2.7\text{mm}$  there is no need to perform the adjustment.

If the adjustment is required, perform the following procedures.

- 4) Enter the SIM 50-12 or 50-6 mode.

(SIM50-12)

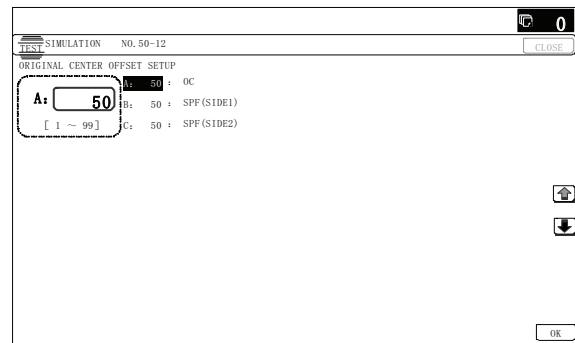

(SIM50-6)

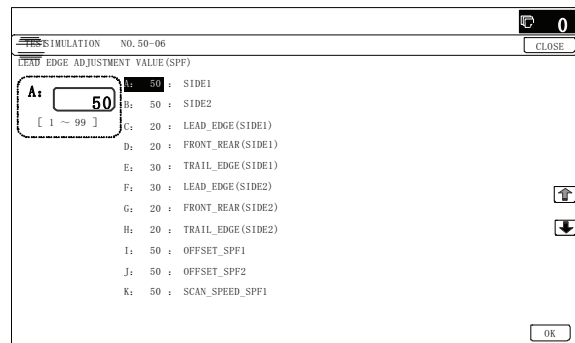

#### SIM50-12

Item	Display	Content	Setting range	Default value
A	OC	Document table image off-center adjustment	1 - 99	50
B	SPF(SIDE1)	SPF front surface image off-center adjustment	1 - 99	50
C	SPF(SIDE2)	SPF back surface image off-center adjustment	1 - 99	50

A - C: When the adjustment value is increased, the image position is shifted to the rear frame side.

1step = 0.1mm

Item/Display		Content	Setting range	Default value
A	SIDE1	Front surface document scan position adjustment (CCD)	1 - 99	50
B	SIDE2	Back surface document scan position adjustment (CCD)	1 - 99	50
C	Image loss amount setting SIDE1	LEAD_EDGE (SIDE1) Front surface lead edge image loss amount setting	0 - 99	20
D	Image loss amount setting SIDE1	FRONT_REAR (SIDE1) Front surface side image loss amount setting	0 - 99	20
E		TRAIL_EDGE (SIDE1) Front surface rear edge image loss amount setting	0 - 99	40
F	Image loss amount setting SIDE2	LEAD_EDGE (SIDE2) Back surface lead edge image loss amount setting	0 - 99	20
G	Image loss amount setting SIDE2	FRONT_REAR (SIDE2) Back surface side image loss amount setting	0 - 99	20
H		TRAIL_EDGE (SIDE2) Back surface rear edge image loss amount setting	0 - 99	40
I	OFFSET_SPF1	RSPF front surface document off-center adjustment	1 - 99	50
J	OFFSET_SPF2	RSPF back surface document off-center adjustment	1 - 99	50
K	SCAN_SPEED_SPF1	RSPF document front surface magnification ratio adjustment (Sub scan)	1 - 99	50
L	SCAN_SPEED_SPF2	RSPF document back surface magnification ratio adjustment (Sub scan)	1 - 99	50

\* Item A, B: When the adjustment value is increased, the scan timing is delayed.

\* Item C - H: When the adjustment value is increased, the image loss is increased.

\* Item A - H: 1 step = 0.1mm change

\* The SPF rear edge image loss setting is provided for countermeasures against the case when shades are produced.

- 5) Select an adjustment mode with the scroll key.

**(SIM50-12)**

SPF(SIDE1) Front surface mode  
SPF(SIDE2) Back surface mode

**(SIM50-6)**

OFFSET SPF1 Front surface mode  
OFFSET SPF2 Back surface mode

- 6) Enter an adjustment value with 10-key, and press [OK] key.

(Change for change in the adjustment value: 0.1mm/step)

(When the adjustment value is increased, the print image is shifted to the rear.)

Repeat the procedures of 2) - 6) until a satisfactory result is obtained.

## ADJ 18 Copy image position and image loss adjustment (Manual adjustment)

### Note

Normally if the adjustment is executed by ADJ 4 (automatic adjustment), there is no need to execute this adjustment.

Only when the manual adjustment is required, execute this adjustment.

In other words, this manual adjustment is executed when a satisfactory result is not obtained from the automatic adjustment (ADJ 4).

### 18-A Copy image position, image loss, and void area adjustment (Manual adjustment) (Document table mode)

This adjustment must be performed in the following cases:

- \* When the scanner (reading) section is disassembled.
- \* When the scanner (reading) unit is replaced.
- \* When the LSU is replaced or removed.
- \* When the registration roller section is disassembled.
- \* U2 trouble has occurred.
- \* The PCU PWB has been replaced.
- \* The EEPROM of the PCU PWB has been replaced.
- \* The scanner control PWB has been replaced.
- \* The EEPROM on the scanner control PWB has been replaced.

### Note

Before executing this adjustment, be sure to confirm that the ADJ 4/ADJ 5 Print engine image skew, image position, image magnification ratio, void area adjustments has been completed normally.

- 1) Place a scale on the document table as shown in the figure below.

Place a scale so that it is in parallel with the scanning direction and that its lead edge is in contact with the document guide plate.

Place white paper on the document table so that the scale lead edge can be seen.

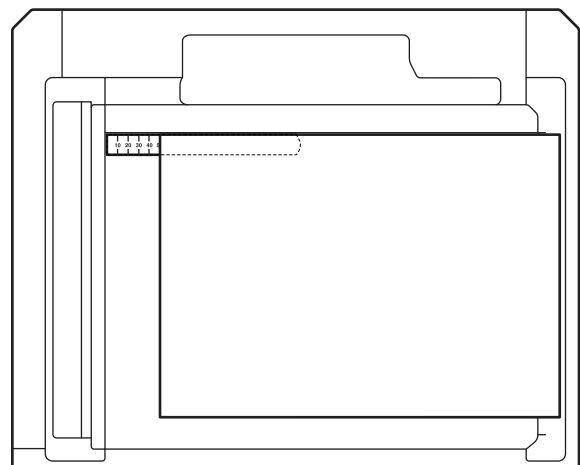

2) Enter the SIM 50-1 mode.

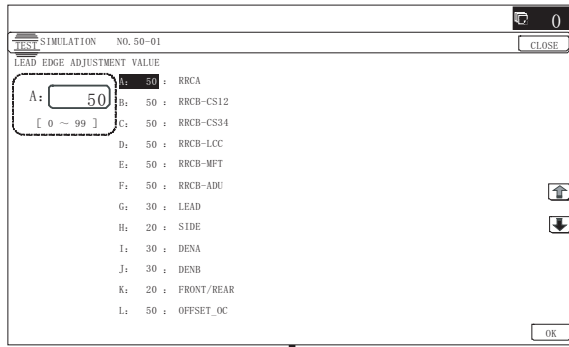

10-key

OK

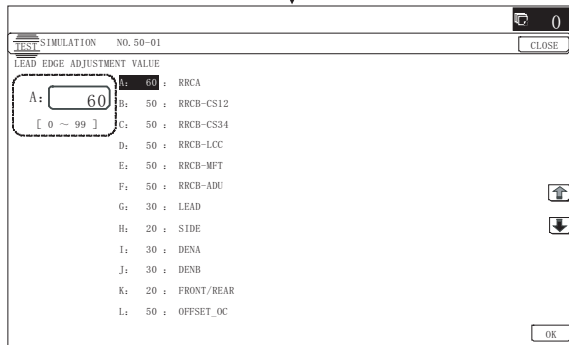

3) Set RRCA, LEAD, and SIDE to the default values.

Item/Display		Content	Setting range	Default value		
A	Lead edge adjustment value	RRCA	Document lead edge reference position (OC)	0 - 99	50	
B		RRCB-CS1	Registration motor ON timing adjustment	Standard Tray	1 - 99	60
C		RRCB-DSK		Desk	1 - 99	60
D		RRCB-LCC		LCC	1 - 99	60
E		RRCB-MFT		Manual paper feed	1 - 99	60
F		RRCB-ADU		ADU	1 - 99	60
G		Image loss area setting value		LEAD	Lead edge image loss area setting	0 - 99
H		SIDE	Side image loss area adjustment	0 - 99	20	
I	Void area adjustment	DENA	Lead edge void area adjustment	1 - 99	40	
J		DENB	Rear edge void area adjustment	1 - 99	30	
K		FRONT/REAR	FRONT/REAR void area adjustment	1 - 99	20	
L	Off-center adjustment	OFFSET_OC	OC document off-center adjustment	1 - 99	50	
M	Magnification ratio correction	SCAN_SPEED_OC	SCAN sub scanning magnification ratio adjustment (CCD)	1 - 99	50	
N	Sub scanning direction print area correction value	DENB-MFT	Manual feed correction value	1 - 99	50	
O		DENB-CS1	Tray 1 correction value	1 - 99	50	
P		DENB-CS2	Tray 2 correction value	1 - 99	50	
Q		DENB-CS3	Tray 3 correction value	1 - 99	50	

Item/Display		Content	Setting range	Default value	
R	Sub scanning direction print area correction value	DENB-CS4	Tray 4 correction value	1 - 99	50
S		DENB-LCC	LCC correction value	1 - 99	50
T		DENB-ADU	ADU correction value	1 - 99	55
U		DENB-HV	Heavy paper correction value	1 - 99	50

4) Perform the image lead edge reference position adjustment. Shift to the copy mode, and make a copy at each of 100% and 200% in the document table mode.

When the adjustment value of RRCA is proper, the lead edge image from 4.0mm is not copied in either of 100% and 200% copy scale.

If not, change and adjust the RRCA value. (Adjust so that the lead edge image from 4.0mm is not copied in either of different copy magnification ratios.)

Repeat the above procedures until a satisfactory result is obtained.

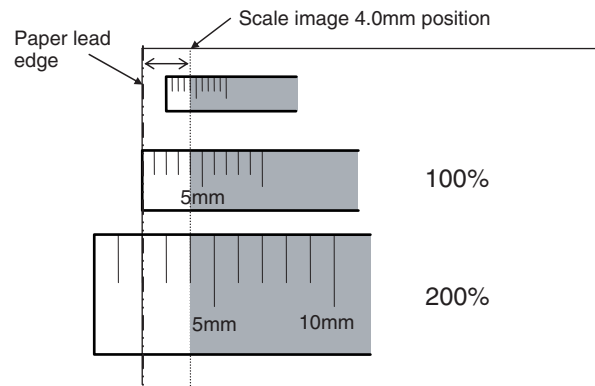

5) Image loss adjustment

When the adjustment item of the image loss below is set to the default value, it is adjusted to the standard state. If it is not in the below standard state, or when it is set to a desired value, change these adjustment items.

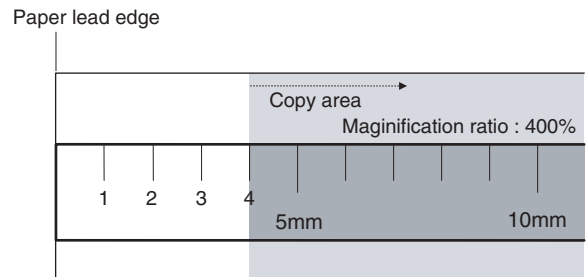

Void area: 4.0mm, Image loss: 4.0mm

Item/Display	Content		Adjustment range	Default value	Standard adjustment value
LEAD	Image loss adjustment	Lead edge image loss adjustment	0 - 99	40	4.0 ± 1.0mm
SIDE		Side image loss adjustment	0 - 99	20	2.0 ± 1.0mm

When the adjustment value is increased, the image loss is increased. When the adjustment value is decreased, the image loss is decreased.

When the adjustment value is changed by 1, the void area is changed by 0.1mm.

## 18-B Image scanning position adjustment (Manual adjustment) (RSPF mode)

This adjustment must be performed in the following cases:

- \* When the scan control PWB is replaced.
- \* When the EEPROM on the scan control PWB is replaced.
- \* When the scanner (reading) section is disassembled.
- \* When the scanner (reading) section is replaced.
- \* When U2 trouble occurs.
- \* When the RSPF section is disassembled.
- \* When the RSPF unit is replaced.

This simulation is to adjust the scanning position when scanning in the RSPF mode.

If this adjustment is made improperly, the scanner stop position is shifted from the specified position and a shade of the document table may be reflected on the lead edge section of the scan image in the RSPF mode.

- 1) Make a copy in the RSPF mode, and check for any shade on the lead edge section of the copy image.

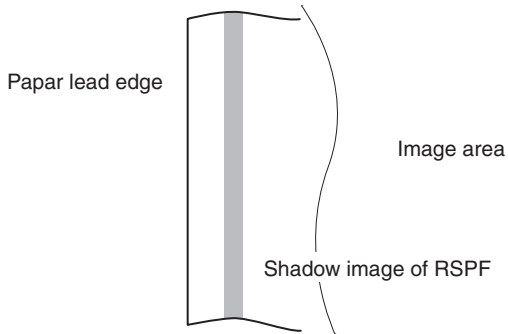

If there is any shade of the document table on the lead edge section of the copy image, perform the following procedures.

- 2) Enter the SIM 53-8 mode, and press [MANUAL] key.

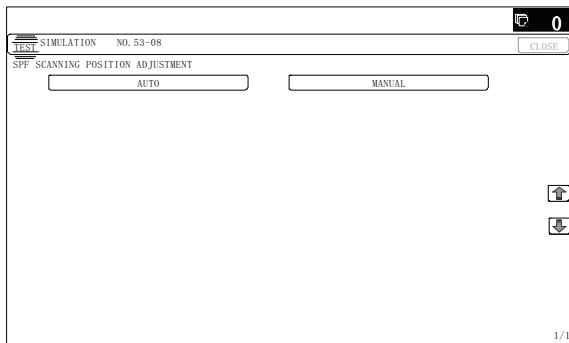

- 3) Enter an adjustment value with 10-key, and press [OK] key.

When the set value is increased, the distance from the home position to the RSPF scanning position is increased. When the set value is changed by 1, the scanning position is changed by 0.1mm.

Perform the procedures of 1) - 3) until a satisfactory result is obtained.

**Important**

After execution of this adjustment, be sure to execute ADJ 18C Copy image position, image loss, void area adjustment (Manual adjustment) (RSPF mode).

## 18-C Copy image position, image loss, void area adjustment (Manual adjustment) (RSPF mode)

This adjustment must be performed in the following cases:

- \* When the scan control PWB is replaced.
- \* When the EEPROM on the scan control PWB is replaced.
- \* When the scanner (reading) section is disassembled.
- \* When the scanner (reading) unit is replaced.
- \* When U2 trouble occurs.
- \* When the RSPF section is disassembled.
- \* When the RSPF unit is replaced.

### a. Adjustment procedures

- 1) Prepare the adjustment chart.

The adjustment chart can be made by the following procedures.

Use A4 (11" x 8.5") paper and draw arrow marks vertically and horizontally on the front and the back surfaces.

At the same time, put marks of the lead edge, the trail edge, the front end, and the rear end as well as the identification marks of the front surface and the back surface.

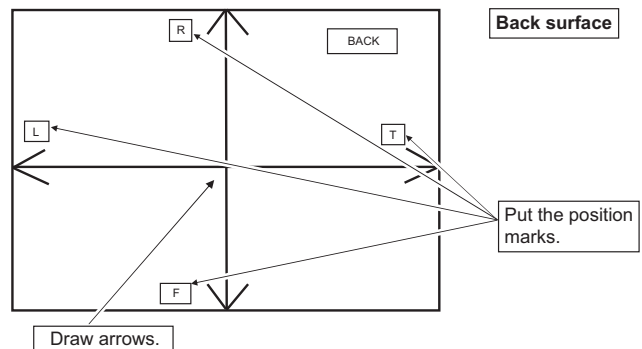
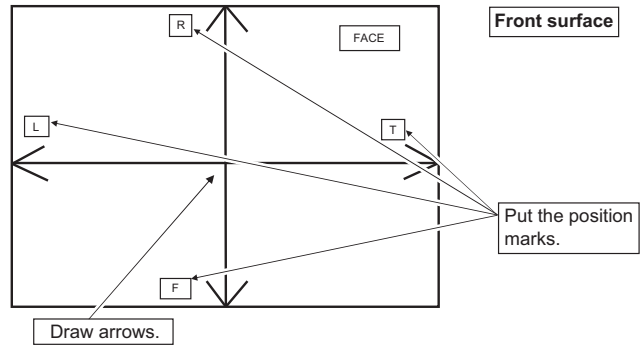

- 2) Enter the SIM 50-6 mode.

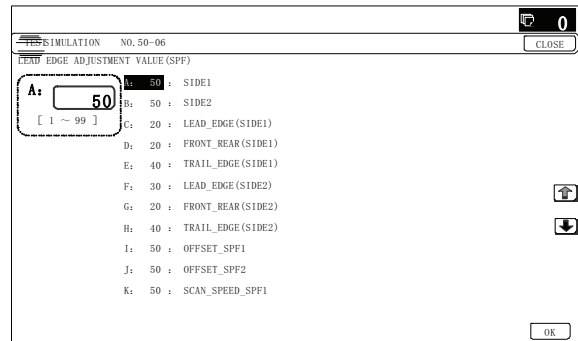

Item/Display		Content	Setting range	Default value
A	SIDE1	Front surface document scan position adjustment (CCD)	1 - 99	50
B	SIDE2	Back surface document scan position adjustment (CCD)	1 - 99	50
C	Image loss amount setting SIDE1	LEAD_EDGE (SIDE1)	0 - 99	20
D		FRONT_REAR (SIDE1)	0 - 99	20
E		TRAIL_EDGE (SIDE1)	0 - 99	40
F	Image loss amount setting SIDE2	LEAD_EDGE (SIDE2)	0 - 99	20
G		FRONT_REAR (SIDE2)	0 - 99	20
H		TRAIL_EDGE (SIDE2)	0 - 99	40
I	OFFSET_SPF1	RSPF front surface document off-center adjustment	1 - 99	50
J	OFFSET_SPF2	RSPF back surface document off-center adjustment	1 - 99	50
K	SCAN_SPEED_SPF1	RSPF document front surface magnification ratio adjustment (Sub scan)	1 - 99	50
L	SCAN_SPEED_SPF2	RSPF document back surface magnification ratio adjustment (Sub scan)	1 - 99	50

- \* Item A, B: When the adjustment value is increased, the scan timing is delayed.
- \* Item C - H: When the adjustment value is increased, the image loss is increased.
- \* Item A - H: 1 step = 0.1mm change
- \* The RSPF rear edge image loss setting is provided for countermeasures against the case when shades are produced.

#### (Lead edge image loss adjustment)

- 1) Set the lead edge image loss adjustment values (LEAD EDGE (SIDE1/SIDE2)) on the front surface and the back surface to the following values.  
(Standard set value)  
TRAIL EDGE (SIDE 1):  
40 Lead edge image loss set value (Front surface)  
TRAIL EDGE (SIDE 2):  
40 Lead edge image loss set value (Back surface)  
(When the set value is increased, the lead edge image loss is increased.)  
(Change for change in the set value: 0.1mm/step)

- 2) Make a duplex copy in 100% in the RSPF mode. Check to confirm that the lead edge image loss is within  $4.0 \pm 1.0\text{mm}$  on the front surface and the back surface. The paper lead edge must be aligned with the presumed image lead edge.

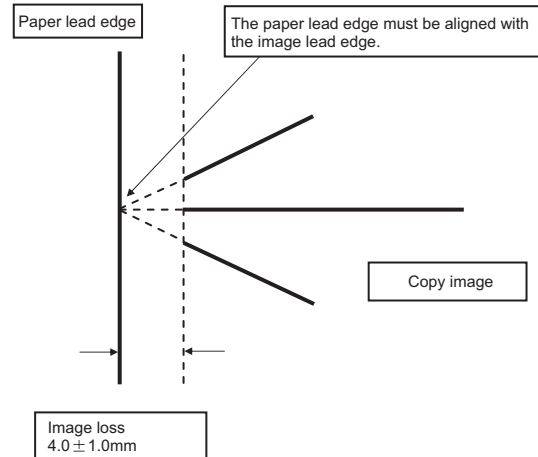

If the above condition is not satisfied, perform the following procedure.

- 3) Enter the adjustment value of SIDE1/SIDE2 with 10-key, and press [OK] key.  
Adjust so that the paper lead edge is aligned with the presumed image lead edge.  
SIDE1: Front surface lead edge scan position adjustment  
SIDE2: Back surface lead edge scan position adjustment  
(When the adjustment value is increased, the print image position is shifted to the delaying direction for the paper.)  
(Change for change in the set value: 0.1mm/step)

Perform the procedures of 2) - 3) until a satisfactory result is obtained.

#### (Rear edge image loss adjustment)

- 1) Make a duplex copy in 100% in the RSPF mode. Check to confirm that the rear edge image loss is 2.0 - 5.0mm on the front surface and the back surface.

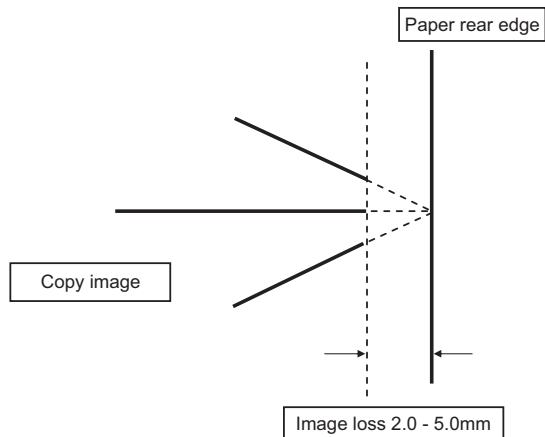

If the above condition is not satisfied, perform the following procedure.

- 2) Enter the adjustment value of TRAIL EDGE (SIDE1/SIDE2) with 10-key, and press [OK] key.

TRAIL EDGE (SIDE 1):

Rear edge image loss adjustment value (Front surface)

TRAIL EDGE (SIDE 2):

Rear edge image loss adjustment value (Back surface)

(When the adjustment value is increased, the rear edge image loss is increased.)

(Change for change in the set value: 0.1mm/step)

Perform the procedures of 1) - 2) until a satisfactory result is obtained.

#### (Front/rear frame direction image loss adjustment)

- 1) Make a duplex copy in 100% in the RSPF mode. Check to confirm that the image losses on the front frame side and the rear frame side are  $2.0 \pm 2.0\text{mm}$  on the front surface and the back surface.

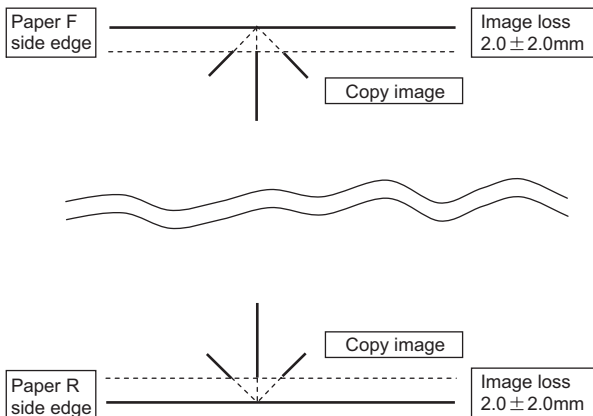

If the above condition is not satisfied, perform the following procedure.

- 2) Enter the adjustment value of FRONT/REAR (SIDE 1) / FRONT/REAR (SIDE 2), and press [OK] key.

FRONT/REAR (SIDE 1):

Front/Rear image loss adjustment value (Front surface)

FRONT/REAR (SIDE 2):

Front/Rear image loss adjustment value (Back surface)

(When the adjustment value is increased, the front/rear image loss is increased.)

(Change for change in the adjustment value: 0.1mm/step)

Perform the procedures of 1) - 2) until a satisfactory result is obtained.

## ADJ 19 Finisher and punch unit adjustments (alignment, punch hole position, staple position)

This adjustment must be performed in the following cases:

- \* When the finisher is disassembled.
- \* When the finisher control PWB is replaced.
- \* When the punch unit is disassembled.
- \* When the punch control PWB is replaced.
- \* When the alignment is improper.
- \* When the punch hole position is shifted.
- \* When the staple position is shifted.

- 1) Enter the SIM 3-10 mode.

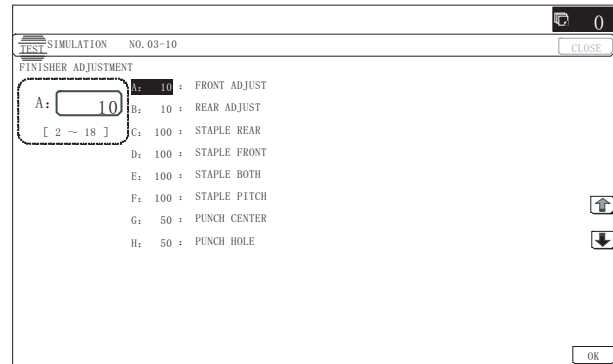

2) Select an adjustment target item with the scroll key.

Item/Display	Content	Setting range	Default value	Purpose (Case where the adjustment is required)	Change when the adjustment value is increased or decreased		Change when the adjustment value is changed by 1	
A	FRONT ADJUST	Alignment position adjustment (F side alignment plate stop position) (Paper alignment adjustment)	2 - 18	10	This adjustment is used to adjust the paper alignment width when the paper alignment is improper. Alignment is determined by the combination of the both adjustment values of FRONT ADJUST and REAR ADJUST.	F side paper alignment stop position (F/R direction)	When the adjustment value is increased, the alignment plate stop position is shifted to the R side. When the adjustment value is decreased, the alignment plate stop position is shifted to the F side.	0.3665mm
B	REAR ADJUST	Alignment position adjustment (R side alignment plate stop position) (Paper alignment adjustment)	2 - 18	10	When changing the adjustment values of FRONT ADJUST and REAR ADJUST from the default values, be sure to change them by the same variation.	R side paper alignment stop position (F/R direction)	When the adjustment value is increased, the alignment plate stop position is shifted to the F side. When the adjustment value is decreased, the alignment plate stop position is shifted to the R side.	0.3665mm
C	STAPLE REAR	Stapling position adjustment (one position at the rear)	68 - 132	100	When the staple position on the R side is shifted, perform the adjustment.	Staple position (Stapler stop position) (F/R direction)	When the adjustment value is increased, the staple position is shifted to the rear side. When the adjustment value is decreased, the staple position is shifted to the front side.	0.155mm
D	STAPLE FRONT	Stapling position adjustment (one position in front)	68 - 132	100	When the staple position on the F side is shifted, perform the adjustment.	Staple position (Stapler stop position) (F/R direction)	When the adjustment value is increased, the staple position is shifted to the rear side. When the adjustment value is decreased, the staple position is shifted to the front side.	0.155mm
E	STAPLE BOTH	Stapling position adjustment (center position of two positions binding)	68 - 132	100	When the staple off-center is shifted, perform the adjustment.	Staple position (Stapler stop position) (F/R direction)	When the adjustment value is increased, the staple position is shifted to the rear side. When the adjustment value is decreased, the staple position is shifted to the front side.	0.155mm
F	STAPLE PITCH	Stapling position adjustment (staple pitch of two positions binding)	68 - 132	100	When it is required to change the staple interval, perform the adjustment.	Staple position (Stapler stop position) (F/R direction)	When the adjustment value is increased, the staple interval is increased. When the adjustment value is decreased, the staple interval is decreased.	0.155mm
G	PUNCH CENTER	Punch center positioning sensor	37 - 63	50	When the punch off-center is shifted, perform the adjustment.	Punch position (F/R direction)	When the adjustment value is decreased, the punch position is shifted to the front side. When the adjustment value is increased, the punch position is shifted to the rear side.	0.1441mm
H	PUNCH HOLE	Punch hole adjustment (paper transport direction)	42 - 58	50	When the punch hole position is shifted in the transport direction, perform the adjustment.	Punch position (Paper transport direction)	When the adjustment value is increased, the punch position is shifted to the paper lead edge side. When the adjustment value is decreased, the punch position is shifted to the paper rear edge side.	0.2584mm

#### Saddle stitch finisher

Item/Display	Content	Setting range	Default value	Purpose (Case where the adjustment is required)	Change when the adjustment value is increased or decreased		Change when the adjustment value is changed by 1	
A	SADDLE POSITION	Saddle stitch position adjustment	25 - 75	50	The adjustment is executed when the saddle staple position is shifted.	Saddle paper lead edge striking plate stop position (Up-down direction)	When the adjustment value is increased, the stapling position is shifted to the lead edge of transported paper. When the adjustment value is decreased, the stapling position is shifted to the rear edge of transported paper.	0.2mm
B	FOLDING POSITION	Saddle folding position adjustment	25 - 75	50	The adjustment is executed when the saddle folding position is shifted.	Saddle paper lead edge striking plate stop position (Up-down direction)	When the adjustment value is increased, the folding position is shifted to the lead edge of transported paper. When the adjustment value is decreased, the folding position is shifted to the rear edge of transported paper.	0.2mm

Item/Display		Content	Setting range	Default value	Purpose (Case where the adjustment is required)	Change when the adjustment value is increased or decreased		Change when the adjustment value is changed by 1
C	FRONT ADJUST	Alignment position adjustment (front)	35 - 65	50	When the paper alignment capability in the stacker section is improper, the paper alignment width is adjusted.	F side paper alignment plate stop position (F/R direction)	When the adjustment value is increased, the alignment position is shifted to the center. When the adjustment value is decreased, the alignment position is shifted to the outside.	0.2mm
D	REAR ADJUST	Alignment position adjustment (Rear)	35 - 65	50		R side paper alignment plate stop position (F/R direction)	When the adjustment value is increased, the alignment position is shifted to the center. When the adjustment value is decreased, the alignment position is shifted to the outside.	0.2mm
E	STAPLE REAR	Stapling position adjustment (Rear, one position)	25 - 75	50	When the stapling position on the R side is shifted, the adjustment is executed.	Stapling position (stapler stop position) (F/R direction)	When the adjustment value is increased, the distance between the stapling position and the paper edge becomes longer. When the adjustment value is decreased, the distance between the stapling position and the paper edge becomes shorter.	0.2mm
F	STAPLE REAR R	Stapling position adjustment (Rear, one position / R series)	45 - 75	50	When the stapling position on the R side is shifted with R series paper, the adjustment is executed.	Stapling position (stapler stop position) (F/R direction)	When the adjustment value is increased, the distance between the stapling position and the paper edge becomes longer. When the adjustment value is decreased, the distance between the stapling position and the paper edge becomes shorter.	0.2mm
G	STAPLE FRONT	Stapling position adjustment (one position in front)	25 - 75	50	When the stapling position on the F side is shifted, the adjustment is executed.	Stapling position (stapler stop position) (F/R direction)	When the adjustment value is decreased, the distance between the stapling position and the paper edge becomes shorter. When the adjustment value is increased, the distance between the stapling position and the paper edge becomes longer.	0.2mm
H	STAPLE FRONT R	Stapling position adjustment (Front, one position / R series)	25 - 55	50	When the stapling position on the F side is shifted with R series paper, the adjustment is executed.	Stapling position (stapler stop position) (F/R direction)	When the adjustment value is decreased, the distance between the stapling position and the paper edge becomes shorter. When the adjustment value is increased, the distance between the stapling position and the paper edge becomes longer.	0.2mm
I	STAPLE BOTH	Stapling position adjustment (Two positions, center)	45 - 55	50	When the staple off-center is shifted, the adjustment is executed.	Stapling position (stapler stop position) (F/R direction)	When the adjustment value is increased, the stapling position is shifted to the front. When the adjustment value is decreased, the stapling position is shifted to the rear.	0.2mm
J	STAPLE PITCH	Stapling position adjustment (Two positions, pitch)	35 - 62	50	When the stapling interval is to be changed, the adjustment is executed.	Stapling position (stapler stop position) (F/R direction)	When the adjustment value is increased, the pitch of two points is widened. When the adjustment value is decreased, the pitch of two points is narrowed.	0.2mm
K	PUNCH CENTER	Punch center adjustment	35 - 65	50	When the punch off-center is shifted, the adjustment is executed.	Punching position (F/R direction)	When the adjustment value is increased, the hole position is shifted to the front. When the adjustment value is decreased, the hole position is shifted to the rear.	0.2mm



Item/Display		Content	Setting range	Default value	Purpose (Case where the adjustment is required)	Change when the adjustment value is increased or decreased		Change when the adjustment value is changed by 1
L	PUNCH HOLE	Punch hole position adjustment	30 - 60	50	When the punch hole position is shifted in the transport direction, the adjustment is executed.	Punch position (paper transport direction)	When the adjustment value is increased, the punch hole position is shifted to the rear edge of paper. When the adjustment value is decreased, the punch hole position is shifted to the lead edge of paper.	0.2mm
M	SADDLE_ADJUST_POS	Saddle alignment position adjustment	35 - 65	50	When the paper alignment capability in the saddle section is improper, the paper alignment width is adjusted.	Saddle paper alignment plate stop position (F/R direction)	When the adjustment value is increased, the alignment plate position is shifted to the center. When the adjustment value is decreased, the alignment plate position is shifted to the outside.	0.2mm
N	GRIPPER_POS	Gripper exit position adjustment	35 - 65	50	When the gripper discharge position is shifted, the adjustment is executed. (When a JAM or trouble occurs, the adjustment is executed.)	Gripper discharge position (Gripper stop position) (F/R direction)	When the adjustment value is increased, the gripper discharge position is shifted to the front. When the adjustment value is decreased, the gripper discharge position is shifted to the rear.	0.2mm

- 3) Enter an adjustment value and press [OK] key.
- 4) Cancel the simulation, make a copy in the mode including the adjustment target, and check the adjustment result.

## [5] SIMULATION

### 1. General and purpose

The simulation mode has the following functions, to display the machine operating status, identify the trouble position and causes in an earlier stage, and to efficiently setup and adjust the machine for improved serviceability.

- 1) Various adjustments
- 2) Setting of the specifications and functions
- 3) Canceling troubles
- 4) Operation check
- 5) Counters check, setting, clear
- 6) Machine operating conditions (operation hysteresis), data check, clear.
- 7) Various (adjustments, setting, operation, counters, etc.) data transport.

The operating procedures and displays depend on the design of the operation panel of the machine.

### 2. Starting the simulation

#### 18cpm/20cpm/23cpm/31cpm(G) machine

##### Entering the simulation mode

- 1) Machine in Copy mode: Select Program key → Asterisk (\*) key → Clear key → Asterisk (\*) key → Ready for input of main code of simulation.
- 2) Entering a main code with the 10-key → START key ON.  
Or select a main code with the SIM key on the touch panel.
- 3) Entering a sub code with the 10-key → START key ON.
- 4) Select an item with the scroll key and the item key.
- 5) The machine enters the mode corresponding to the selected item. Press [START] key or [EXECUTE] key to start the simulation operation.

To cancel the current simulation mode and change the main code and the sub code, press [SYSTEM SETTING] key.

##### Canceling the simulation mode to return to the normal mode

- 1) Press [CA] key.

#### 26cpm/36cpm/31cpm(A) machine

- 1) Double-click the [HOME] key. (Total use quantity/Toner remaining quantity display mode screen)

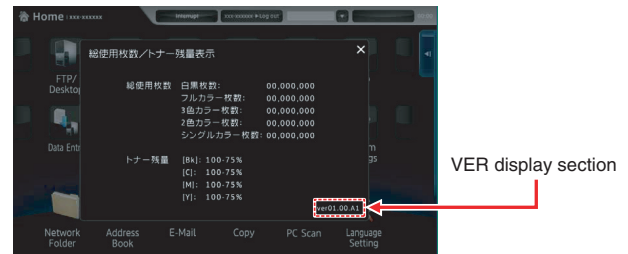

Touch the VER display section. Touch the [BACK] key.

##### (10-key mode input mode screen)

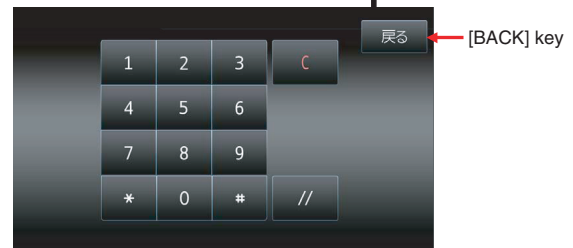

- 2) Touch the VER display section. (10-key mode input mode screen)
- 3) Touch the (#) key → Asterisk (\*) key → Clear key → Asterisk (\*) key → Ready for input of main code of simulation.
- 4) Enter a main SIM code with the 10-key pad then touch the START key or select a main code from the SIM key list on the touch panel.
- 5) Enter a sub code with the 10-key pad, then touch the START key or select a sub code from the code list on the touch panel.
- 6) Select an item with the scroll key and the item key.
- 7) The machine enters the mode corresponding to the selected item. Press [START] key or [EXECUTE] key to start the simulation operation.

To cancel the current simulation mode and change the main code and the sub code, press [BACK] key.

##### Canceling the simulation mode to return to the normal mode

- 1) Press [EXIT] key.

#### Important

Do not turn OFF the power when the machine is in the simulation mode.

If the power switch should be turned OFF in the simulation mode, a malfunction may be resulted. In this case, turn OFF/ON the main power source.

18cpm/20cpm/23cpm/31cpm(G) machine

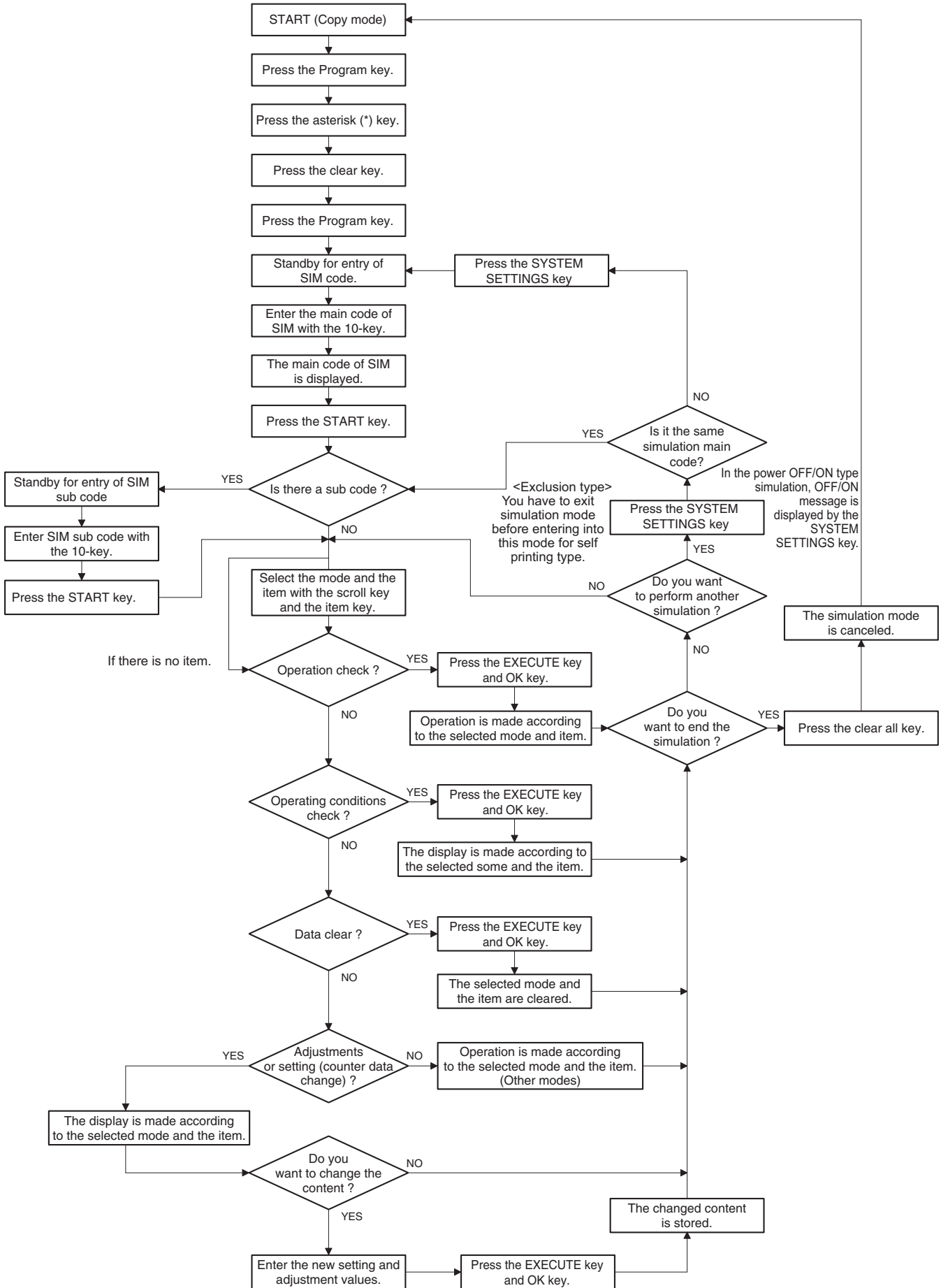

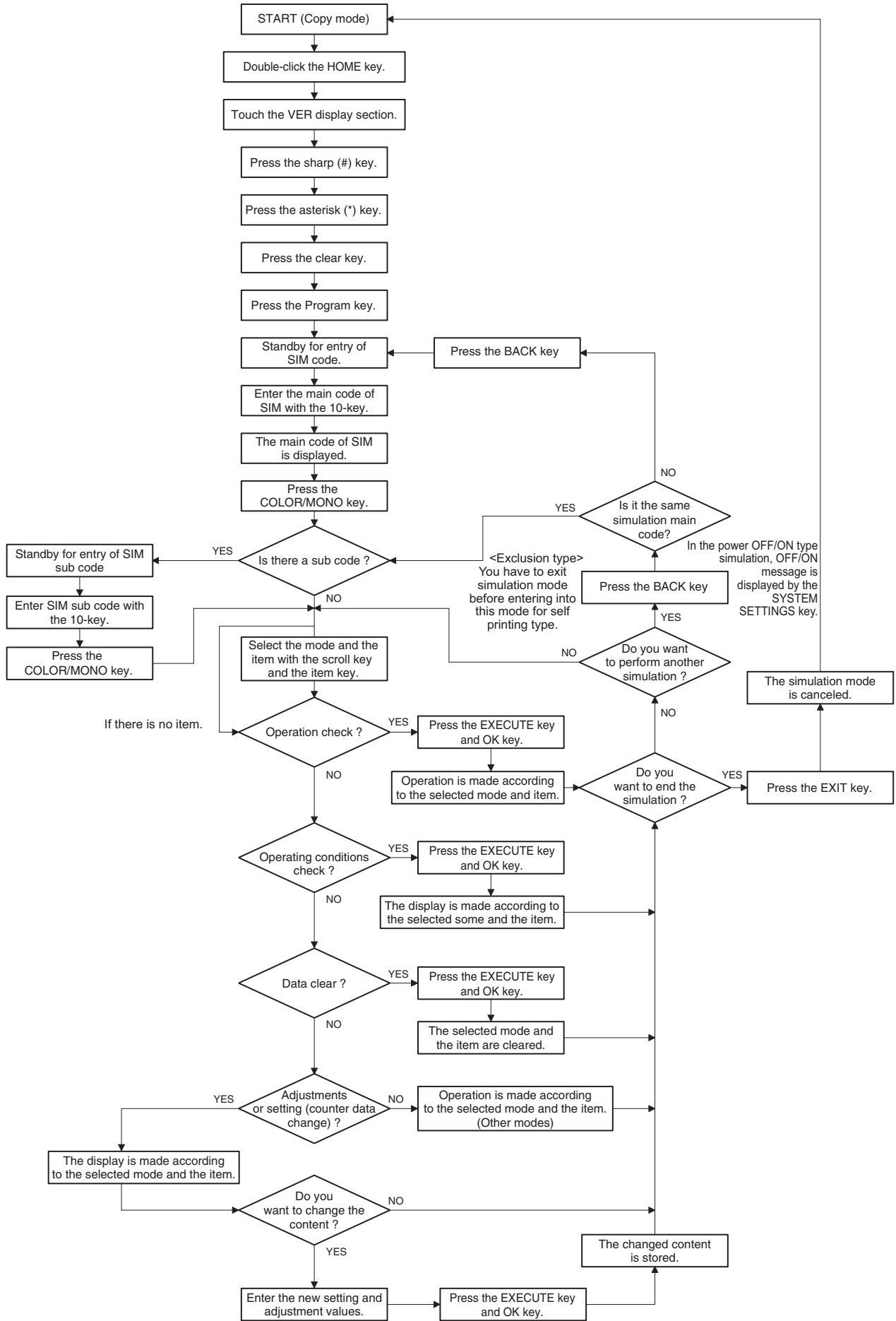

### 3. List of simulation codes

Main	Sub	Functions	Section
1	1	Used to check the operation of the scanner (reading) unit and the control circuit.	Scanner (reading)
	2	Used to check the sensors in the scanner (reading) section and the related circuits.	Scanner (reading)
	5	Used to check the operation of the scanner (reading) unit and the control circuit.	Scanner (reading)
2	1	Used to check the operations of the automatic document feeder and the control circuit.	RSPF
	2	Used to check the operations of the sensors and the detectors in the automatic document feeder section and the control circuits.	RSPF
	3	Used to check the operations of the loads in the automatic document feeder and the control circuit.	RSPF
3	2	Used to check the operations of the sensors and the detectors in the finisher and the control circuit.	Finisher
	3	Used to check the operation of the load in the finisher and the control circuit.	Finisher
	10	Used to adjust the finisher.	Finisher
4	2	Used to check the operations of the sensors and detectors in the desk/large capacity tray (LCC), and the control circuit of those.	Desk/Large capacity tray (LCC)
	3	Used to check the operations of the loads in the desk/large capacity tray (LCC), and the control circuit of those.	Desk/Large capacity tray (LCC)
	5	Used to check the operations of the paper feed desk paper transport clutch (DTRC) and the LCC paper transport clutch (LTRC).	Desk/Large capacity tray (LCC)
5	1	Used to check the operation of the display, LCD in the operation panel, and control circuit.	Operation panel
	2	Used to check the operation of the heater lamp and the control circuit.	Fusing
	3	Used to check the operation of the scanner lamp and the control circuit.	Scanner (reading)
	4	Used to check the operation of the discharge lamp and the control circuit.	Process
6	1	Used to check the operations of the load in the paper transport system (clutches and solenoids) and the control circuits.	Paper transport/Paper exit section
	2	Used to check the operations of each fan motor and its control circuit.	Others
	3	Used to check the operations of the transport unit and the control circuit.	Process (Transport)
	6	Used to perform fusing pressure release and applying, and to check the operations of the control circuits.	Fusing
	90	Used to reset the machine to the factory setting. (The scanner is set to the lock enable position)	Scanner
7	1	Used to set the operating conditions of aging.	Others
	6	Used to set the operating intermittent aging cycle.	
	8	Used to display the warm-up time.	
	9	Color setting in the color copy test mode (Used to check the copy operation and the image quality for each color).	
	12	The document reading number of sheets setting (for aging operation)	RSPF
8	1	Used to check and adjust the operations of the developing voltage in each print mode and the control circuit. * When the middle speed is adjusted, the low speed are also adjusted simultaneously.	Process (Developing)
	2	Used to check and adjust the operation of the main charger grid voltage in each printer mode and the control circuit. * When the middle speed is adjusted, the low speed are also adjusted simultaneously.	Process (Charging)
	6	Used to check and adjust the operation of the transport voltage and the control circuit.	Process (Transport)
9	2	Used to check the operations of the sensors and detectors in the paper reverse section (duplex section) and its control circuit.	Duplex
	3	Used to check the operations of the load in the paper reverse section (duplex section) and its control circuit.	Duplex
10	1	Used to check the operations of the toner supply mechanism (toner motor) and the related circuit.	Process (Developing)
13	-	Used to cancel the self-diag "U1" trouble.	
14	-	Used to cancel the self-diag H3, H4, H5 troubles.	
15	-	Used to cancel the self-diag "U6" trouble.	LCC
16	-	Used to cancel the self-diag "U2" trouble.	MFP PWB / PCU PWB / SCU PWB
17	-	Used to cancel the self-diag "PF" trouble.	
21	1	Used to set the maintenance cycle.	
22	1	Used to check the print count value in each section and each operation mode. (Used to check the maintenance timing.)	
	2	Used to check the total number of misfeed and troubles. (When the number of total jam is considerably great, it is judged as necessary for repair.)	
	3	Used to check misfeed positions and the misfeed count of each position. * Presumption of the faulty point by this data is possible.	
	4	Used to check the trouble (self diag) history.	
	5	Used to check the ROM version of each unit (section).	Firmware
	6	Used to output the setting/adjustment data (simulation, FAX soft switch, counter), the firmware version, and the counter list.	
	8	Used to check the number of operations (counter value) of the finisher, the RSPF, and the scan (reading) unit.	
	9	Used to check the number of use (print quantity) of each paper feed section.	Paper feed, ADU, LCC
	10	Used to check the system configuration (option, internal hardware).	
	11	Used to check the use frequency (send/receive) of FAX. (Only when FAX is installed)	FAX
	12	Used to check the RSPF misfeed positions and the number of misfeed at each position. (When the number of misfeed is considerably great, it can be judged as necessary for repair.)	RSPF
	13	Used to check the operating time of the process section (OPC drum, DV unit, toner cartridge) and the fusing unit	Process
	14	Used to display the use status of the toner cartridge.	Process

Main	Sub	Functions	Section
22	18	Used to display the user data delete history.	
	19	Used to check the values of the counters related to the scan - image send.	
	40	Used to display the error code list and the contents.	
	90	Used to output the various set data lists.	
23	2	Used to output the trouble history list of paper jam and misfeed. (If the number of troubles of misfeed is considerably great, the judgment is made that repair is required.)	
	80	Used to check the operation of paper feed and paper transport in the paper feed section and the paper transport section. Used to output the list of the operation status of the sensor and the detectors in the paper feed section and the paper transport section.	Paper feed, Paper transport
24	1	Used to clear the jam counter, and the trouble counter. (After completion of maintenance, clear the counters.)	
	2	Used to clear the number of use (the number of prints) of each paper feed section.	
	3	Used to clear the finisher, RSPF, and the scan (reading) unit counter.	
	4	Used to clear the maintenance counter, the printer counters of the transport unit and the fusing unit. (After completion of maintenance, clear the counters.)	
	5	Used to clear the developer counter. (After replacement of developer, clear the counter.)	
	6	Used to clear the copy counter.	
	9	Used to clear the printer mode print counter and the self print mode print counter.	
	10	Used to clear the FAX counter. (Only when FAX is installed)	
	15	Used to clear the counters related to the scan mode and the image send.	
25	35	Used to clear the toner cartridge use status data.	
	1	Used to check the operations of the developing section.	Process (Developing section)
	2	Used to make the initial setting of toner density when replacing developer. (Automatic adjustment)	Image process (Photoconductor/ Developing/Transfer/Cleaning)
	4	Used to display the operation data of the toner supply quantity. (Not used in the market.)	Process
	5	Used to display the toner density correction data. (Not used in the market.)	Process
26	1	Used to set Yes/No of installation of the right paper exit tray.	Paper exit
	2	Used to set the paper size of the large capacity tray (LCC). (When the paper size is changed, this simulation must be executed to change the paper size in software.)	Paper feed
	3	Used to set the specifications of the auditor. (Setting must be made according to the auditor use conditions.)	Auditor
	5	Used to set the count mode of the total counter and the maintenance counter. (A3/11x17 size)	
	6	Used to set the specifications (paper, fixed magnification ratio, etc.) of the destination.	
	7	Used to set the machine ID. (26cpm/36cpm/31cpm(A) machine)	
	10	Used to set the trial mode of the network scanner.	
	18	Used to set Disable/Enable of the toner save mode operation. (For the Japan and the UK versions.)	
	30	Used to set the operation mode corresponding to the CE mark (Europe safety standards). (For slow start to drive the fusing heater lamp)	
	32	Used to set the specifications of the fusing cleaning operation.	Fusing
	35	Used to set the display mode of SIM 22-4 trouble history when a same trouble occurred repeatedly. There are two display modes: display as one trouble and display as several series of troubles.	
	38	Used to set Continue/Stop of print when the maintenance life is reached.	
	41	Used to set Enable/Disable of the magnification ratio automatic select function (AMS) in the center binding mode.	
	49	Used to set the print speed of postcards mode.	
	50	Used to set functions.	
	51	Used to set the specifications of the serial port operation. (For PCI)	
	52	Used to set whether non-printed paper (insertion paper, cover paper) is counted up or not.	
53	User auto color calibration (color balance adjustment) Inhibit/Allow setting.		
65	Used to set the finisher alarm mode.		
69	Used to set the operating conditions for toner near end.		
71	Used to set the trial mode of the web browsing function. (26cpm/36cpm/31cpm(A) machine)		
73	Enlargement continuous shoot, A3 wide copy mode image loss (shade delete quantity) adjustment		
74	Used to set the OSA trial mode.		
78	Used to set the password of the remote operation panel.		
79	Used to set YES/NO of the pop-up display of user data delete result.		

Main	Sub	Functions	Section	
27	1	Used to set non-detection of communication error (U7-00) with RIC. (FSS function)		
	2	Used to set the sender's registration number and the HOST server telephone number. (FSS function)		
	4	Used to set the initial call and toner order auto send. (FSS function)		
	5	Used to set the machine tag No. (This function allows the host computer to check the machine tag No.) (FSS function)	Communication (RIC/MODEM)	
	6	Used to set of the manual service call. (FSS function)		
	7	Used to set of the enable, alert callout. (FSS function)		
	9	Used to set the paper transport time recording YES/NO threshold value and shading gain adjustment retry number. (FSS function)		
	10	Used to clear the trouble prediction history information. (FSS function)		
	11	Used to check the serial communication retry number and the scanner gain adjustment retry number history. (FSS function)		
	12	Used to check the high density, halftone process control and the automatic registration adjustment error history. (FSS Function)		
	13	Used to check the history of paper transport time between sensors. (FSS function)		
	14	Used to set the FSS function connection test mode.		
	15	Used to display the FSS connection status.		
	16	Used to set the FSS alert send.		
	17	Used to set the FSS paper order alert.		
	18	Used to clear the FSS paper feed retry counter.		
	30	1	Used to check the operations of the sensors and the detectors in other than the paper feed section and the control circuits.	
		2	Used to check the operations of the sensors and the detectors in the paper feed section and the control circuits.	
33	2	Used to delete the ID (IDM) information of Felica card. (23cpm/31cpm(G) machine only)		
40	2	Manual paper feed tray paper width sensor adjustment.	Paper feed	
	7	Used to set the adjustment value of the manual paper feed tray paper width sensor.	Paper feed	
41	1	Used to check the operations of the document size sensor and the control circuit.		
	2	Used to adjust the document size sensor detection level.		
	3	Used to check the operations of the document size sensor and the control circuit.		
43	1	Used to set the fusing temperature in each mode.		
	4	Used to set the fusing temperature 2 in each mode. (Continued from SIM 43-1.)		
	20	Used to set the environmental correction under low temperature and low humidity (L/L) for the fusing temperature setting (SIM 43-1) in each paper mode.		
	21	Used to set the environment correction under high temperature and high humidity (H/H) for the fusing temperature setting (SIM 43-1) in each paper mode.		
	22	Used to set the environment correction under low temperature and low humidity (L/L) for the fusing temperature setting (SIM 43-4) in each paper mode.		
	23	Used to set the environment correction under high temperature and high humidity (H/H) for the fusing temperature setting (SIM 43-4) in each paper mode.		
	24	Used to set the correction of the temperature adjustment value of SIM 43-1 and 43-4.		
	31	Used to check the operation of the fusing web cleaning. (36cpm machine)	Fusing	
	32	Used to set various items related to the forcible operation of web cleaning when job end. (36cpm machine)	Fusing	
	44	1	Used to set each correction operation function in the image forming (process) section.	Image process (Photoconductor/Developing/Transfer/Cleaning)
2		Used to adjust the sensitivity of the image density sensor (registration sensor).	Process	
4		Used to set the conditions of the high density process control operation.	Process	
6		Used to execute the high density process control forcibly.	Process	
9		Used to display the result data of the high density process control operation.	Image process (Photoconductor/Developing/Transfer/Cleaning)	
12		Used to display the operation data of the high density process control and the image density sensor (registration sensor).	Image process (Photoconductor/Developing)	
13		Used to perform the color image sensor (image registration sensor F) calibration.		
14		Used to display the output level of the temperature and humidity sensor.	Process (OPC drum, development)/Fusing/LSU	
15		Used to set the OPC drum idle rotation.	Process	
21		Used to set the halftone process control target.	Process	
22		Used to display the toner patch density level in the halftone process control operation.	Process	
24		Used to display the correction target and the correction level in the halftone process control operation.	Process	
25		Used to set the calculating conditions of the correction value for the halftone process control.	Process	
26		Used to execute the halftone process control compulsory.	Process	
27		Used to clear the correction data of the halftone process control.	Process	
28		Used to set the process control execution conditions.	Process	
29		Used to set the operating conditions of the process control during a job.	Process	
31		Used to adjust the OPC drum phase. (Manual adjustment)	Process	
37		Used to set the development bias correction level in the continuous printing operation.		
43		Used to display the identification information of the developing unit.	Developing system	
61	Used to adjust the color image density sensor. (The adjustment is made according to the input of SIM44-13 to set the target value of the color sensor gain adjustment.)			
62	Used to set the process control execution conditions.	Process		

Main	Sub	Functions	Section
46	1	Used to adjust the copy density in the copy mode.	
	2	Used to adjust the copy density in the copy mode.	
	4	Used to adjust the density in the image send mode.	
	5	Used to adjust the density in the image send mode.	
	8	Used to adjust the image send mode color balance RGB.	
	9	Used to adjust the scan image density.	
	10	Used to adjust the copy color balance and the gamma (for each color copy mode).	
	16	Used to adjust the monochrome copy density and the gamma (for each monochrome copy mode).	
	19	Used to set the operating conditions for the density scanning (exposure) of monochrome auto copy mode documents.	
	21	Copy color balance adjustment (Manual adjustment)	
	23	Used to set the density correction of copy high density section (High density tone gap supported).	
	24	Copy color balance adjustment (Auto adjustment)	
	25	Used to adjust the copy color balance. (Single color copy mode)	
	26	Used to reset the single color mode color balance set value to the default.	
	27	Used to adjust the gamma/density of copy images, texts, and line image edges.	
	30	Used to adjust the resolution in the sub scanning direction in the copy mode.	
	32	Used to adjust the document background density reproducibility in the monochrome auto copy mode.	
	36	Used to adjust the colors in the 2-color copy mode.	
	37	Used to adjust the reproduction capability of monochrome mode color.	
	38	Used to adjust the black component amount in the color copy mode.	
	39	Used to adjust the sharpness of FAX send images.	
	40	Used to adjust the FAX send image density. (Collective adjustment of all the modes)	
	41	Used to adjust the FAX send image density. (Normal)	
	42	Used to adjust the FAX send image density. (Fine)	
	43	Used to adjust the FAX send image density. (Super Fine)	
	44	Used to adjust the FAX send image density. (Ultra fine)	
	45	Used to adjust the FAX send image density. (600dpi).	
	46	Used to adjust the FAX send image density. (RGB RIP) (26cpm/36cpm/31cpm(A) machine)	
	47	Used to set the compression rate of copy and scan images (JPEG).	
	51	Used to adjust the gamma for the copy mode heavy paper mode and the image process mode.	
	52	Used to set the gamma default for the copy mode heavy paper and the image process mode. (After execution of either SIM46-54 or SIM46-51, the adjustment value is reset to the initial value.)	
	54	Used to perform the engine halftone automatic density adjustment (dither).	
	55	Used to adjust the drop out color in the image send mode (monochrome manual text mode). (26cpm/36cpm/31cpm(A) machine)	
	58	Used to set the copy mode pseudo resolution. (Smoothing process)	
59	Used to perform the copy mode pseudo resolution image process adjustment.		
60	Used to adjust the sharpness in the color auto copy mode.		
61	Used to adjust the area separation recognition level.		
62	Used to set the operating conditions of the ACS, the area separation, the background image process, and the auto exposure mode.		
63	Used to adjust the density in the copy low density section.		
65	Used to set the color correction table.		
66	Used to adjust the reproduction capability of watermarks in the copy/printer mode. (26cpm/36cpm/31cpm(A) machine)		
74	Copy color balance adjustment (Auto adjustment)/Printer color balance adjustment (Auto adjustment)		
90	Used to set the process operation of high-compression PDF images. (26cpm/36cpm/31cpm(A) machine)		
91	Used to adjust the reproduction capability of black text. (26cpm/36cpm/31cpm(A) machine)		
48	1	Used to adjust the scan image magnification ratio (in the main scanning direction and the sub scanning direction).	
	5	Used to correction the scan image magnification ratio (in the sub scanning direction).	Scanner section
	6	Used to adjust the rotation speed of each motor.	
49	1	Used to perform the firmware update.	
	3	Used to update the operation manual in the HDD.	
	5	Used to perform the watermark update.	



Main	Sub	Functions	Section
50	1	Copy image position, image loss adjustment	
	2	Used to adjust the copy image position and the image loss. (This simulation is a simplified version of SIM 50-1.) (18cpm/20cpm/23cpm/31cpm(G) machine)	
	5	Used to adjust the print lead edge image position. (PRINTER MODE)	
	6	Used to adjust the copy image position and the image loss. (RSPF mode)	RSPF
	7	Used to adjust the copy image position and the image loss (RSPF mode). (This simulation is a simplified version of SIM 50-6.) (18cpm/20cpm/23cpm/31cpm(G) machine)	RSPF
	10	Used to adjust the black print image magnification ratio and the off-center position. (The adjustment is made separately for each paper feed section.)	
	12	Used to perform the scan image off-center position adjustment. (The adjustment is made separately for each scan mode.)	
	20	Image registration adjustment (Main scanning direction)	
	22	Used to adjust the image registration. (Main scan direction, sub scan direction) (Auto adjustment)/OPC drum phase adjustment (Auto adjustment)	
	24	Used to display the detail data of SIM 44-2, 50-20, 21 and 22.	
	27	Used to perform the image loss adjustment of scanned images in the FAX or image send mode.	
	28	Used to automatically adjust the image loss, void area, image off-center, and image magnification ratio.	
51	1	Used to adjust the ON/OFF timing of the secondary transport voltage.	
	2	Used to adjust the contact pressure (deflection amount) on paper by the main unit and the RSPF resist roller. (This adjustment is performed when there is a considerable variation in the print image position on the paper or when paper jams frequently occur.)	
53	6	Used to adjust the detection level of the RSPF document width.	
	7	Used to adjust the RSPF document size width sensor.	
	8	Used to adjust the document lead edge reference and the RSPF mode document scan position.	
55	1	Used to set the specifications of the engine control operations. (SOFT SW)	
	2	Used to set the specifications of the scanner control operation. (SOFT SW)	
	3	Used to set the specifications of the controller operation. (SOFT SW)	
	10	Used to set the special stamp text. (Taiwan only)	
56	1	Used to transport data between HDD - MFP PWB SRAM/EEPROM. (Used to repair the PWB.)	
	2	Used to backup the data in the EEPROM, SD Card, and HDD (including user authentication data and address data) to the USB memory. (Corresponding to the device cloning and the storage backup.)	
	3	Used to backup the document filing data to the USB memory.	
	4	Used to backup the JOB log data to the USB memory.	
	5	Used to import the SIM22-6 data to a USB memory in the TEXT format.	
	11	Used to copy the SD Card data to an option HDD.	MFP PWB/HDD
	12	Used to copy the SD Card data to an option HDD.	MFP PWB/HDD
60	1	Used to check the memory operations (read/write) of the MFP PWB.	
61	1	Used to check the LSU polygon motor rotation and laser detection.	LSU
	3	Used to set the laser power	
	4	Used to print the print image skew adjustment pattern. (LSU unit)	
62	1	Used to format the hard disk/SD Card. (HDD: Excluding the Operation manual and the watermark data) (SD Card: User data)	
	2	Used to check read/write of the hard disk (partial).	
	3	Used to check read/write of the hard disk (all areas).	
	6	Used to perform the self diagnostics of the hard disk.	
	7	Used to print the hard disk self diagnostics error log.	
	8	Used to format the hard disk/SD Card. (HDD: Excluding the Operation Manual, the watermark data, and the system area) (SD Card: User data)	
	10	Used to clear the job completion list data.	
	11	Used to delete the document filing data.	
	12	Used to set Enable/Disable of auto format in a hard disk trouble.	
	13	Used to format the hard disk. (Operation Manual, watermark data only)	
	14	Used to delete the document filing management data.	HDD
	15	Used to convert the setting data for document filing reprint.	MFP
	20	Used to check the operation of the mirroring hard disk. (26cpm/36cpm/31cpm(A) machine)	Mirroring hard disk
63	1	Used to display the shading correction result.	Scanner
	2	Used to perform shading.	
	3	Used to perform scanner (CCD) color balance and gamma auto adjustment.	Scanner
	4	Used to display the SIT chart patch density.	
	5	Used to perform the scanner (CCD) color balance and gamma default setting.	
	6	Used to display the scan level and the density level of the copy color balance adjustment patch.	
	7	Used to register the service target of the copy mode auto color balance adjustment.	
	8	Used to set the default of the service target of the copy mode auto color balance adjustment.	
	11	Used to set the target color balance of the copy mode auto color balance adjustment.	
64	1	Test print. (Self print) (Color mode)	
	2	Test print. (Self print) (Monochrome mode)	
	4	Printer test print. (Self print)	
	5	Printer test print. (Self print) (PCL)	
	6	Printer test print. (Self print) (PS)	
	7	Used to print the adjustment pattern of the test print. (Self print). (The adjustment pattern of SIM46-21 is printed.)	

Main	Sub	Functions	Section
65	1	Used to adjust the touch panel (LCD display section) detection coordinates.	Operation panel section
	2	Used to display the touch panel (LCD display section) detection coordinates.	
	5	Used to check the operation panel key input.	
66	1	Used to display the FAX-related soft SW (2 - 150) on the LCD to allow changing the soft SW while checking with the LCD.	FAX
	2	Used to enter a country code and set the default value for the country code.	FAX
	3	Used to check read/write of the EEPROM and the SDRAM on the MODEM controller and display the result.	FAX
	4	Used to send the selected signals to the line and the main unit speaker. (Send level: max.)	FAX
	5	Used to send the selected signal to the line and the main unit speaker. (Send level: Soft SW setting) (For the kinds of send signals, refer to SIM66-04.)	FAX
	6	Used to print the confidential registration check table (BOX NO., BOX name, passcode. (If there is no confidential registration, no print is made.)	FAX
	7	Used to output all image data saved in the image memory. (Confidential data are also outputted.)	FAX
	8	Used to send the selected sound messages to the line and the speaker. (Send level: Max.)	FAX
	9	Used to send the selected sound message to the line and the speaker. (Send level: Soft SW setting) * For details of sound messages, refer to the sound message table of SIM66-08.	FAX
	10	Used to clear the FAX and image send image data. (The confidential data are also cleared.)	FAX
	11	Used to send the selected signal at 300bps to the line and the speaker. (Send level: Max.)	FAX
	12	Used to send the selected signal at 300bps to the line and the speaker. (Send level: Soft SW setting) * For the kinds of send signals at 300bps, refer to SIM66-11, 300bps send signal table.	FAX
	13	Used to register dial numbers for SIM66-14/15/16, Dial test. (Up to 20 digits can be registered.)	FAX
	14	Used to execute the dial pulse (10PPS) send test and to adjust the make time.	FAX
	15	Used to execute the dial pulse (20PPS) send test and to adjust the make time.	FAX
	16	Used to execute the DTFM signal send test and to adjust the send level.	FAX
	17	Used to send the DTMF signal to the line and the speaker. (Send level: Max.)	FAX
	18	Used to send the DTMF signal to the line and the speaker. (Send level: Soft SW setting)	FAX
	21	Used to print the selected items (system error, protocol monitor).	FAX
	22	Used to set the handset sound volume. (This simulation can be executed even though the handset setting is set to NO. When, however, the handset is not installed, the sound volume cannot be checked.) (Japan model only)	FAX
	24	Used to clear the FAST save data.	FAX
	29	Used to initialize the telephone book data (the one-touch registration table, the FTP/Desktop expansion table, the group expansion table, the program registration table, the interface memory box table, the meta data, InboundRouting, and the DocumentAdmin table).	FAX
	30	Used to display the TEL/LIU status change. The display is highlighted by status change.	FAX
	31	Used to set ON/OFF the port for output to TEL/LIU.	FAX
	32	Used to check the fixed data received from the line and to display the result.	FAX
	33	Used to execute detection of various signals with the line connected and to display the detection result. When a signal is detected, the display is highlighted.	FAX
	34	Used to execute the send test and display the time required for sending image data in the test. Used to execute send test and display. (Unit: ms)	FAX
36	Used to check send and receive data from the MODEM controller to the MFP controller or the data line or the command line individually.	FAX	
39	Used to check and change the destination setting saved in EEPROM of the FAX BOX.	FAX	
42	Used to rewrite the program to power control installed in the FAX BOX.	FAX	
43	Used to write the adjustment value into the power control installed in the FAX BOX.	FAX	
61	Used to display the FAX-related soft SW (151 - 250) on the LCD to allow changing the soft SW while checking with the LCD.	FAX	
62	Used to import the FAX receive data into a USB memory in PDF file type.	FAX	
67	17	Printer reset	Printer
	24	Printer color balance adjustment (Auto adjustment)	Printer
	25	Printer color balance adjustment (Manual adjustment)	Printer
	26	Used to set the target color balance of the printer mode auto color balance adjustment.	Printer
	27	Used to set the service target of the printer mode auto color balance adjustment.	Printer
	28	Used to set the default of the service target of the printer mode auto color balance adjustment.	Printer
	31	Used to clear the printer calibration value.	Printer
	33	Used to change the gamma of the printer screen.	Printer
	34	Used to set the density correction in the printer high density section. (Support for the high density section tone gap)	Printer
	36	Used to adjust the density in the low density section.	Printer
	45	Used to adjust the printer image filter and trapping.	Printer
	52	Used to set the default of the gamma of the printer screen.	Printer
	54	Printer color balance adjustment (Automatic adjustment for each dither (The adjustment is disable in a GDI printer.))	Printer

## 4. Details of simulation

1

1-1	
<b>Purpose</b>	Operation test/check
<b>Function (Purpose)</b>	Used to check the operation of the scanner (reading) unit and the control circuit.
<b>Section</b>	Scanner (reading)

### Operation/Procedure

- 1) Select the operation speed with the touch panel key.
- 2) Press [EXECUTE] key.  
Scanning is once performed at the speed corresponding to the scan resolution (operation speed).

Item/Display		Operation mode	Default value
OC SCAN	300DPI	300DPI (346.0mm/s)	300DPI (346.0mm/s)
	400DPI	400DPI (259.5mm/s)	
	600DPI	600DPI (173.0mm/s)	
	1200DPI	1200DPI (86.5mm/s)	

1-2	
<b>Purpose</b>	Operation test/check
<b>Function (Purpose)</b>	Used to check the sensors in the scanner (reading) section and the related circuits.
<b>Section</b>	Scanner (reading)

### Operation/Procedure

The operating status of the sensor is displayed.  
When "MHPS" is highlighted, the scanner unit is in the home position.

1-5	
<b>Purpose</b>	Operation test/check
<b>Function (Purpose)</b>	Used to check the operation of the scanner (reading) unit and the control circuit.
<b>Section</b>	Scanner (reading)

### Operation/Procedure

- 1) Select the operation speed with the touch panel key.
- 2) Press [EXECUTE] key.  
Scanning is repeated at the speed corresponding to the scan resolution (operation speed).  
When [EXECUTE] key is pressed, the operation is terminated.

Item/Display		Operation mode	Default value
OC SCAN	300DPI	300DPI (346.0mm/s)	300DPI (346.0mm/s)
	400DPI	400DPI (259.5mm/s)	
	600DPI	600DPI (173.0mm/s)	
	1200DPI	1200DPI (86.5mm/s)	

2

2-1	
<b>Purpose</b>	Operation test/check
<b>Function (Purpose)</b>	Used to check the operations of the automatic document feeder and the control circuit.
<b>Section</b>	RSPF

### Operation/Procedure

- 1) Select the operation mode and the speed with the touch panel key.
- 2) Press [EXECUTE] key.  
The RSPF repeats paper feed, transport, and paper exit operations at the speed corresponding to the scan resolution (operation speed).  
When [EXECUTE] key is pressed, the operation is terminated.

### [RSPF]

Item/Display		Operation mode	Default value
(SINGLE)	300DPI	300DPI (259.5mm/s)	300DPI (259.5mm/s)
	400DPI	400DPI (259.5mm/s)	
	600DPI	600DPI (173.0 mm/s)	
(DOUBLE)	300DPI	300DPI (259.5mm/s)	300DPI (259.5mm/s)
	400DPI	400DPI (259.5mm/s)	
	600DPI	600DPI (173.0 mm/s)	

2-2	
<b>Purpose</b>	Operation test/check
<b>Function (Purpose)</b>	Used to check the operations of the sensors and the detectors in the automatic document feeder section and the control circuits.
<b>Section</b>	RSPF

### Operation/Procedure

The operating conditions of the sensors and detectors are displayed.  
The code names of the sensors and the detectors which are active are highlighted.

Display	Content
SPED	Document sensor
SPPD1	Document transport sensor 1
SPLS1	Paper size detector 1
SPLS2	Paper size detector 2
S OCD	RSPF open/close sensor
SPPD2	Document transport sensor 2
SPPD3	Document transport sensor 3
SPPD4	Document transport sensor 4
SCOV	RSPF cover open/close detector
SSET	SPF installation detection
STMPU	SPF stamp UN installation detection
SWD_LEN	SPF document guide plate position (Unit: 0.1mm)
SWD_AD	SPF document detection volume output AD value

**Important**

SWD\_LEN and SWD\_AD are not ON/OFF display.

**2-3**

<b>Purpose</b>	Operation test/check
<b>Function (Purpose)</b>	Used to check the operations of the loads in the automatic document feeder and the control circuit.
<b>Section</b>	RSPF

**Operation/Procedure**

- 1) Select a target item of the operation check with the touch panel key.
- 2) Press [EXECUTE] key.  
The selected load performs the operation.  
When [EXECUTE] key is pressed, the operation is terminated.

Display	Content
SPUM_F	RSPF paper feed motor (normal rotation)
SPUM_R	RSPF paper feed motor (reverse rotation)
SPFM_F	RSPF transport motor (normal rotation)
SPFM_R	RSPF transport motor (reverse rotation)
SPRS	Paper exit roller pressure control solenoid (RSPF)
SRRC	Registration roller clutch (RSPF)
STMP	Stamp solenoid

**3**

**3-2**

<b>Purpose</b>	Operation test/check
<b>Function (Purpose)</b>	Used to check the operations of the sensors and the detectors in the finisher and the control circuit.
<b>Section</b>	Finisher

**Operation/Procedure**

The operating conditions of the sensors and detectors are displayed.

The code names of the sensors and the detectors which are active are highlighted.

**Inner finisher (MX-FN17)**

Display	Content
FABHS	Paper alignment belt HP sensor
FAPHPS_F	Paper alignment plate HP sensor F
FAPHPS_R	Paper alignment plate HP sensor R
FDRPS	Paper exit roller position sensor
FDLLS	Paper exit tray lower limit sensor
FDTPD	Delivery tray paper detector
FDTULS	Paper exit tray upper limit sensor
FFL	Fan lock signal
FPCHPS	Punch home position sensor
FPD	Punch unit detection (connector)
FPDFS	Punch dust sensor
FPES1	Punch paper edge sensor 1
FPES2	Punch paper edge sensor 2
FPES3	Punch paper edge sensor 3
FPES4	Punch paper edge sensor 4
FPES5	Punch paper edge sensor 5
FPES6	Punch paper edge sensor 6
FPES7	Punch paper edge sensor 7
FPHPS	Punch unit home position sensor
FPLD1	Paper height detector 1
FPLD2	Paper height detector 2
FPMRS	Punch motor rotation sensor
FPMS	Punch mode sensor
FPPD1	Paper entry detector
FPTS	Punch timing sensor
FSED	Staple empty detector
FSHPS	Staple HP sensor

Display	Content
FSLD	Staple lead edge detector
FSSHPS	Stapler shift home position sensor
FSSS	Staple safety sensor
FSSW	Safety switch
FSTPD	Staple tray paper detector
FTPS	Tray position sensor

**Saddle stitch finisher (MX-FN10)**

FATPD	Paper alignment tray paper detector
FCD	Connection detector
FCD1	Cover detector 1
FCD2	Cover detector 2
FDRHS	Delivery roller home position sensor
FDTPD	Delivery tray paper detector
FFL	Fan lock signal
FGHPS	Gripper home position sensor
FPAPHS_F	Paper alignment plate home position sensor F
FPAPHS_R	Paper alignment plate home position sensor R
FPCHPS	Punch home position sensor
FPD	Punch unit detection (connector)
FPDD	Delivery detector
FPDFS	Punch dust sensor
FPES1	Punch paper edge sensor 1
FPES2	Punch paper edge sensor 2
FPES3	Punch paper edge sensor 3
FPES4	Punch paper edge sensor 4
FPHHS	Paper hold home position sensor
FPHPS	Punch unit home position sensor
FPLD	Paper surface detector
FPMRS	Punch motor rotation sensor
FPMS	Punch mode sensor
FPPD1	Paper transport detector 1
FPPD2	Paper transport detector 2
FPPD3	Paper transport detector 3
FPTS	Punch timing sensor
FSAPHS	Saddle alignment plate home position sensor
FSATPD	Saddle paper alignment tray paper detector
FSED	Staple empty detector
FSHS	Staple home position sensor
FSLS	Staple lead edge sensor
FSMRS	Saddle motor rotation sensor
FSPGHS	Saddle paper guide home position sensor
FSPHS	Saddle plate home position sensor
FSRHS	Saddle roller home position sensor
FSSCS	Saddle staple cover sensor
FSSES	Saddle staple sensor
FSSHPS	Stapler shift home position sensor
FSSHS	Saddle staple home position sensor
FSSSHS	Saddle stapler shift home position sensor
FSSSW1	Staple safety switch
FSSSW2	Stapler safety switch 2
FSSW1	Safety switch 1
FSTPD	Saddle exit tray paper detector
FLLD	Tray lower limit detector
FTLMRS	Tray lift motor rotation sensor
FTPS	Tray position sensor
FTULD	Tray upper limit detector
PDOS	Paper pass cover Open/Close sensor
PDPPD1	Paper pass paper transport detector 1
PDPPD2	Paper pass paper transport detector 2

<b>Purpose</b>	Operation test/check
<b>Function (Purpose)</b>	Used to check the operation of the load in the finisher and the control circuit.
<b>Section</b>	Finisher

**Operation/Procedure**

- 1) Select the item to be operation checked with the touch panel key.
- 2) Press [EXECUTE] key.  
The selected load performs the operation.  
When [EXECUTE] key is pressed, the operation is terminated.

**Inner finisher (MX-FN17)**

Display	Content
FCF	Cooling fan
FDRLM	Paper exit roller lift motor
FPAM_F	Paper alignment motor F
FPAM_R	Paper alignment motor R
FPAS	Paper alignment solenoid
FPDM	Paper exit motor
FPGS	Paper gate solenoid
FPLDS	Paper height detector solenoid
FPM	Punch motor
FPS	Paddle solenoid
FPSM	Punch shift motor
FPTM	Paper transport motor
FSM	Staple motor
FSSM	Stapler shift motor
FTLM	Tray lift motor

**Saddle stitch finisher (MX-FN10)**

Display	Content
FDRLM	Paper exit roller lift motor
FGM	Gripper motor
FPAM_F	Paper alignment motor F
FPAM_R	Paper alignment motor R
FPHS1	Paper holding solenoid 1
FPHS2	Paper holding solenoid 2
FPM	Punch motor
FPSM	Punch shift motor
FPTM1	Paper transport motor 1
FPTM2	Paper transport motor 2
FSDM	Saddle motor
FSDSM	Saddle staple motor
FSM	Staple motor
FSPAM	Saddle paper alignment motor
FSPM	Saddle positioning motor
FSPTM	Saddle paper transport motor
FSSM	Stapler shift motor
FTLM	Tray lift motor
PDCF	Paper pass cooling fan
PDPGS	Paper pass paper gate solenoid
PDPTM	Paper pass paper transport motor

<b>Purpose</b>	Adjustment
<b>Function (Purpose)</b>	Used to adjust the finisher.
<b>Section</b>	Finisher

**Operation/Procedure**

- 1) Select an adjustment target item with scroll key on the touch panel.
- 2) Enter the set value with 10-key.
- 3) Press [OK] key. (The set value is saved.)

**Inner finisher (MX-FN17)**

Item/Display	Content	Setting range	Default value	Purpose (Case where the adjustment is required)	Change when the adjustment value is increased or decreased	Change when the adjustment value is changed by 1	
A	FRONT ADJUST	Alignment position adjustment (F side alignment plate stop position) (Paper alignment adjustment)	2 - 18	10	This adjustment is used to adjust the paper alignment width when the paper alignment is improper. Alignment is determined by the combination of the both adjustment values of FRONT ADJUST and REAR ADJUST.	F side paper alignment stop position (F/R direction) When the adjustment value is increased, the alignment plate stop position is shifted to the R side. When the adjustment value is decreased, the alignment plate stop position is shifted to the F side.	0.3665mm
B	REAR ADJUST	Alignment position adjustment (R side alignment plate stop position) (Paper alignment adjustment)	2 - 18	10	When changing the adjustment values of FRONT ADJUST and REAR ADJUST from the default values, be sure to change them by the same variation.	R side paper alignment stop position (F/R direction) When the adjustment value is increased, the alignment plate stop position is shifted to the F side. When the adjustment value is decreased, the alignment plate stop position is shifted to the R side.	0.3665mm
C	STAPLE REAR	Stapling position adjustment (one position at the rear)	68 - 132	100	When the staple position on the R side is shifted, perform the adjustment.	Staple position (Stapler stop position) (F/R direction) When the adjustment value is increased, the staple position is shifted to the rear side. When the adjustment value is decreased, the staple position is shifted to the front side.	0.155mm
D	STAPLE FRONT	Stapling position adjustment (one position in front)	68 - 132	100	When the staple position on the F side is shifted, perform the adjustment.	Staple position (Stapler stop position) (F/R direction) When the adjustment value is increased, the staple position is shifted to the rear side. When the adjustment value is decreased, the staple position is shifted to the front side.	0.155mm

Item/Display		Content	Setting range	Default value	Purpose (Case where the adjustment is required)	Change when the adjustment value is increased or decreased		Change when the adjustment value is changed by 1
E	STAPLE BOTH	Stapling position adjustment (center position of two positions binding)	68 - 132	100	When the staple off-center is shifted, perform the adjustment.	Staple position (Stapler stop position) (F/R direction)	When the adjustment value is increased, the staple position is shifted to the rear side. When the adjustment value is decreased, the staple position is shifted to the front side.	0.155mm
F	STAPLE PITCH	Stapling position adjustment (staple pitch of two positions binding)	68 - 132	100	When it is required to change the staple interval, perform the adjustment.	Staple position (Stapler stop position) (F/R direction)	When the adjustment value is increased, the staple interval is increased. When the adjustment value is decreased, the staple interval is decreased.	0.155mm
G	PUNCH CENTER	Punch center positioning sensor	37 - 63	50	When the punch off-center is shifted, perform the adjustment.	Punch position (F/R direction)	When the adjustment value is decreased, the punch position is shifted to the front side. When the adjustment value is increased, the punch position is shifted to the rear side.	0.1441mm
H	PUNCH HOLE	Punch hole adjustment (paper transport direction)	42 - 58	50	When the punch hole position is shifted in the transport direction, perform the adjustment.	Punch position (Paper transport direction)	When the adjustment value is increased, the punch position is shifted to the paper lead edge side. When the adjustment value is decreased, the punch position is shifted to the paper rear edge side.	0.2584mm

#### Saddle stitch finisher (MX-FN10)

Item/Display		Content	Setting range	Default value	Purpose (Case where the adjustment is required)	Change when the adjustment value is increased or decreased		Change when the adjustment value is changed by 1
A	SADDLE POSITION	Saddle stitch position adjustment	25 - 75	50	The adjustment is executed when the saddle staple position is shifted.	Saddle paper lead edge striking plate stop position (Up-down direction)	When the adjustment value is increased, the stapling position is shifted to the lead edge of transported paper. When the adjustment value is decreased, the stapling position is shifted to the rear edge of transported paper.	0.2mm
B	FOLDING POSITION	Saddle folding position adjustment	25 - 75	50	The adjustment is executed when the saddle folding position is shifted.	Saddle paper lead edge striking plate stop position (Up-down direction)	When the adjustment value is increased, the folding position is shifted to the lead edge of transported paper. When the adjustment value is decreased, the folding position is shifted to the rear edge of transported paper.	0.2mm
C	FRONT ADJUST	Alignment position adjustment (front)	35 - 65	50	When the paper alignment capability in the stacker section is improper, the paper alignment width is adjusted.	F side paper alignment plate stop position (F/R direction)	When the adjustment value is increased, the alignment position is shifted to the center. When the adjustment value is decreased, the alignment position is shifted to the outside.	0.2mm
D	REAR ADJUST	Alignment position adjustment (Rear)	35 - 65	50		R side paper alignment plate stop position (F/R direction)	When the adjustment value is increased, the alignment position is shifted to the center. When the adjustment value is decreased, the alignment position is shifted to the outside.	0.2mm
E	STAPLE REAR	Stapling position adjustment (Rear, one position)	25 - 75	50	When the stapling position on the R side is shifted, the adjustment is executed.	Stapling position (stapler stop position) (F/R direction)	When the adjustment value is increased, the distance between the stapling position and the paper edge becomes longer. When the adjustment value is decreased, the distance between the stapling position and the paper edge becomes shorter.	0.2mm

Item/Display		Content	Setting range	Default value	Purpose (Case where the adjustment is required)	Change when the adjustment value is increased or decreased		Change when the adjustment value is changed by 1
F	STAPLE REAR R	Stapling position adjustment (Rear, one position /R series)	45 - 75	50	When the stapling position on the R side is shifted with R series paper, the adjustment is executed.	Stapling position (stapler stop position) (F/R direction)	When the adjustment value is increased, the distance between the stapling position and the paper edge becomes longer. When the adjustment value is decreased, the distance between the stapling position and the paper edge becomes shorter.	0.2mm
G	STAPLE FRONT	Stapling position adjustment (one position in front)	25 - 75	50	When the stapling position on the F side is shifted, the adjustment is executed.	Stapling position (stapler stop position) (F/R direction)	When the adjustment value is decreased, the distance between the stapling position and the paper edge becomes shorter. When the adjustment value is increased, the distance between the stapling position and the paper edge becomes longer.	0.2mm
H	STAPLE FRONT R	Stapling position adjustment (Front, one position / R series)	25 - 55	50	When the stapling position on the F side is shifted with R series paper, the adjustment is executed.	Stapling position (stapler stop position) (F/R direction)	When the adjustment value is decreased, the distance between the stapling position and the paper edge becomes shorter. When the adjustment value is increased, the distance between the stapling position and the paper edge becomes longer.	0.2mm
I	STAPLE BOTH	Stapling position adjustment (Two positions, center)	45 - 55	50	When the staple off-center is shifted, the adjustment is executed.	Stapling position (stapler stop position) (F/R direction)	When the adjustment value is increased, the stapling position is shifted to the front. When the adjustment value is decreased, the stapling position is shifted to the rear.	0.2mm
J	STAPLE PITCH	Stapling position adjustment (Two positions, pitch)	35 - 62	50	When the stapling interval is to be changed, the adjustment is executed.	Stapling position (stapler stop position) (F/R direction)	When the adjustment value is increased, the pitch of two points is widened. When the adjustment value is decreased, the pitch of two points is narrowed.	0.2mm
K	PUNCH CENTER	Punch center adjustment	35 - 65	50	When the punch off-center is shifted, the adjustment is executed.	Punching position (F/R direction)	When the adjustment value is increased, the hole position is shifted to the front. When the adjustment value is decreased, the hole position is shifted to the rear.	0.2mm
L	PUNCH HOLE	Punch hole position adjustment	30 - 60	50	When the punch hole position is shifted in the transport direction, the adjustment is executed.	Punch position (paper transport direction)	When the adjustment value is increased, the punch hole position is shifted to the rear edge of paper. When the adjustment value is decreased, the punch hole position is shifted to the lead edge of paper.	0.2mm
M	SADDLE_ADJUST_POS	Saddle alignment position adjustment	35 - 65	50	When the paper alignment capability in the saddle section is improper, the paper alignment width is adjusted.	Saddle paper alignment plate stop position (F/R direction)	When the adjustment value is increased, the alignment plate position is shifted to the center. When the adjustment value is decreased, the alignment plate position is shifted to the outside.	0.2mm
N	GRIPPER_POS	Gripper exit position adjustment	35 - 65	50	When the gripper discharge position is shifted, the adjustment is executed. (When a JAM or trouble occurs, the adjustment is executed.)	Gripper discharge position (Gripper stop position) (F/R direction)	When the adjustment value is increased, the gripper discharge position is shifted to the front. When the adjustment value is decreased, the gripper discharge position is shifted to the rear.	0.2mm

# 4

4-2

<b>Purpose</b>	Operation test/check
<b>Function (Purpose)</b>	Used to check the operations of the sensors and detectors in the desk/large capacity tray (LCC), and the control circuit of those.
<b>Section</b>	Desk/Large capacity tray (LCC)

## Operation/Procedure

The operating conditions of the sensors and detectors are displayed.

The code names of the sensors and the detectors which are active are highlighted.

## Desk

Display	Content
D1MDC	Desk 1 installation detection connector
D1PPD	Desk 1 paper transport detector
D1ULD	Desk 1 upper limit detector
D1PED	Desk 1 paper empty detector
D1PQD	Desk 1 remaining paper quantity detector
D1PRED1	Desk 1 paper rear edge detector 1
D1PRED2	Desk 1 paper rear edge detector 2
D1PRED3	Desk 1 paper rear edge detector 3
D1PRED4	Desk 1 paper rear edge detector 4
D2MDC	Desk 2 installation detection connector
D2PPD	Desk 2 paper transport detector
D2ULD	Desk 2 upper limit detector
D2PED	Desk 2 paper empty detector
D2PQD	Desk 2 remaining paper quantity detector
D2PRED1	Desk 2 paper rear edge detector 1
D2PRED2	Desk 2 paper rear edge detector 2
D2PRED3	Desk 2 paper rear edge detector 3
D2PRED4	Desk 2 paper rear edge detector 4

## LCC

Display	Content
LPFD	LCC transport detector
LUD	LCC tray upper limit detector
LDD	LCC tray lower limit detector
LPED	LCC tray paper empty detector
LCLD	LCC tray open/close detector
LDSW	LCC upper open/close detection switch
LRE	LCC lift motor encoder sensor
L24VM	LCC24V power monitor
LLSW	LCC upper limit switch
LCCD	LCC main unit connection detector

4-3

<b>Purpose</b>	Operation test/check
<b>Function (Purpose)</b>	Used to check the operations of the loads in the desk/large capacity tray (LCC), and the control circuit of those.
<b>Section</b>	Desk/Large capacity tray (LCC)

## Operation/Procedure

- 1) Select the load item that is required to operation check with the touch panel key.
- 2) Press [EXECUTE] key.  
The selected load performs the operation.  
When [EXECUTE] key is pressed, the operation is terminated.

## Desk

Display	Content
D1LM	Tray 1 lift-up motor
D1PFC	Tray 1 paper feed clutch
D2LM	Tray 2 lift-up motor
D2PFC	Tray 2 paper feed clutch
DPFM	Desk transport motor
DPTRC	Desk paper transport clutch

## LCC

Display	Content
LPFM	LCC transport motor
LLM	LCC lift motor
LPFC	LCC paper feed clutch
LPFS	LCC paper feed solenoid
LTRC	LCC transport clutch

4-5

<b>Purpose</b>	Operation test/check
<b>Function (Purpose)</b>	Used to check the operations of the paper feed desk paper transport clutch (DTRC) and the LCC paper transport clutch (LTRC).
<b>Section</b>	Desk/Large capacity tray (LCC)

## Operation/Procedure

### Check the ON operation

Press the button of the code name for checking the ON operation.  
Checking is started. When the operation is normal, the button on the display is highlighted. When it is abnormal, the button is not highlighted.

### Check the OFF operation

Press the highlighted button which is ON.  
When the operation is normal, the highlighted button on the display returns to the normal display. When it is abnormal, the highlighted display is maintained.

Button	Content
DTRC	Desk transport clutch
LTRC	LCC transport clutch

# 5

5-1

<b>Purpose</b>	Operation test/check
<b>Function (Purpose)</b>	Used to check the operation of the display, LCD in the operation panel, and control circuit.
<b>Section</b>	Operation panel

## Operation/Procedure

The LCD is changed as shown below.  
The contrast changes every 2sec from the current level to MAX → MIN → the current level. During this period, each LED is lighted.  
The LCD display contrast change and the LED lighting status are checked.



5-2

<b>Purpose</b>	Operation test/check
<b>Function (Purpose)</b>	Used to check the operation of the heater lamp and the control circuit.
<b>Section</b>	Fusing

**Operation/Procedure**

- 1) Select the item to be operation checked with the touch panel key.
- 2) Press [EXECUTE] key.

The selected heater lamp operates ON/OFF.

When [EXECUTE] key is pressed, the operation is terminated.

Heater lamp operation check method:

Remove the front cabinet upper and the paper exit tray, and the lighting status of each heater lamp can be checked through the clearance between the fusing pressure release drive gear and the frame fusing section.

HL_LM	Heater lamp (B) (Back surface)
HL_UM	Main heater lamp (F) (Front surface)
HL_US	Sub heater lamp (F) (Front surface)

5-3

<b>Purpose</b>	Operation test/check
<b>Function (Purpose)</b>	Used to check the operation of the scanner lamp and the control circuit.
<b>Section</b>	Scanner (reading)

**Operation/Procedure**

- 1) Select the item to be operation checked with the touch panel key.
- 2) Press [EXECUTE] key.

The scanner lamp lights up for 10 sec.

When [EXECUTE] key is pressed, the operation is terminated.

5-4

<b>Purpose</b>	Operation test/check
<b>Function (Purpose)</b>	Used to check the operation of the discharge lamp and the control circuit.
<b>Section</b>	Process

**Operation/Procedure**

- 1) Select a target of the operation check with the touch panel key.  
When [ALL] key is pressed, all the items are selected.
- 2) Press [EXECUTE] key.

The selected discharge lamp is lighted for 30 sec.

When [EXECUTE] key is pressed, the operation is terminated.

DL_K	Discharge lamp K
DL_C	Discharge lamp C
DL_M	Discharge lamp M
DL_Y	Discharge lamp Y

6

6-1

<b>Purpose</b>	Operation test/check
<b>Function (Purpose)</b>	Used to check the operations of the load in the paper transport system (clutches and solenoids) and the control circuits.
<b>Section</b>	Paper transport/Paper exit section

**Operation/Procedure**

- 1) Select the item to be operation checked with the touch panel key.
- 2) Press [EXECUTE] key.

The selected load performs the operation.

When [EXECUTE] key is pressed, the operation is terminated.

Load operation check method:

The load operation is checked by the operation sound. However, there are some loads which cannot be checked with the operation sound.

Section	Item/Display	Content
Transport/ process	ADUC1	ADU transport clutch 1
	PFM	Transport motor
	RRM	Registration motor
	POMF (*1)	Paper exit motor (normal rotation)
	POMR (*1)	Paper exit motor (reverse rotation)
	FUM	Fusing motor
	CPFM	Paper feed motor
	OSM	Offset motor
	CPFC1	Tray vertical transport clutch 1
	CPFC2	Tray vertical transport clutch 2
	TRC_DSK	Desk clutch
	TRC_LCC (*2)	LCC clutch
	TRC_FIN	Finisher clutch
	HPFC	Transport roller clutch
	PFC	Vertical transport clutch
RRC	Registration roller clutch	
Paper feed	CLUM1	Paper tray lift motor (Paper feed tray 1)
	CPUC1	Paper feed clutch (Paper feed tray 1)
	CLUM2	Paper tray lift motor (Paper feed tray 2)
	CPUC2	Paper feed clutch (Paper feed tray 2)
	CPUS1	Paper feed pickup solenoid (Paper feed tray 1) (Not used)
	MPFS	Paper feed solenoid (Manual paper feed)

\*1: If "Normal rotation" and "Reverse rotation" of a same load are displayed as different items, when the both are selected at the same time, "Normal rotation" is performed. In addition, a change in the rotating direction is accepted only when the operation is stopped.

\*2: Displayed but not installed in some models.

<b>6-2</b>	
<b>Purpose</b>	Operation test/check
<b>Function (Purpose)</b>	Used to check the operations of each fan motor and its control circuit.
<b>Section</b>	Others

**Operation/Procedure**

- 1) Select the item to be operation checked with the touch panel key.
- 2) Press [EXECUTE] key.  
The selected load performs the operation.  
When [EXECUTE] key is pressed, the operation is terminated.  
Press [ALL] key to select all the fans collectively.

Load operation check method:

The load operation is checked by the operation sound. However, there are some loads which cannot be checked with the operation sound.

**18/20/23/26/31cpm machine**

Display	Content
PROFM2	Process fan 2
POFM	Paper exit cooling fan (Drives POFM1 and POFM2 at the same time.)
FUFM	Fusing cooling fan
PROFM1	Process fan 1
PSFM	Power cooling fan

**36cpm machine**

Display	Content
POFM	Paper exit cooling fan motor (Drives POFM1 and POFM2 at the same time.)
PSFM	Power cooling fan motor
PROFM1	Process fan motor 1
PROFM2	Process fan motor 2
FUFM	Fusing fan motor
LSUFM	LSU cooling fan motor

<b>6-3</b>	
<b>Purpose</b>	Operation test/check
<b>Function (Purpose)</b>	Used to check the operations of the transport unit and the control circuit.
<b>Section</b>	Process (Transport)

**Operation/Procedure**

- 1) Select the operation mode with the mode select button.

Mode select button	Content
TC1	Primary transfer (normal rotation)
TC1_R	Primary transfer (reverse rotation)
TC2	Secondary transfer

- 2) When [EXECUTE] key is pressed, the operation of the mode selected in 1) is performed.

Mode select button	Mode display	Content	NOTE
TC1	BLACK	Monochrome mode position	Black mode position → Color mode position → Black mode position → Drum separation position → (Black mode position) (Repeated in this sequence.)
	COLOR	Color mode position	
	FREE	Non-transport position	
TC1_R	BLACK	Monochrome mode position	Black mode position → Drum separation position → Color mode position → (Black mode position) (Repeated in this sequence.)
	FREE	Non-transport position	
	COLOR	Color mode position	

Mode select button	Mode display	Content	NOTE
TC2	PRINT	Print position	Print position - Transfer position - Non-transfer position (Repeated in this sequence)
	FREE	Non-transport position	

<b>6-6</b>	
<b>Purpose</b>	Operation test/check
<b>Function (Purpose)</b>	Used to perform fusing pressure release and applying, and to check the operations of the control circuits.
<b>Section</b>	Fusing

**Operation/Procedure**

- 1) Press [FUSER] key to highlight it.
- 2) Press [EXECUTE] key, and fusing pressure applying and fusing pressure release are repeated.

During this period, the status of the fusing roller pressure is displayed.

PRINT	Fusing pressure applying	Fusing pressure applying → Fusing pressure release → (Fusing pressure applying) The operation is repeated.
FREE	Fusing pressure release	

<b>6-90</b>	
<b>Purpose</b>	Setting
<b>Function (Purpose)</b>	Used to reset the machine to the factory setting. (The scanner is set to the lock enable position)
<b>Section</b>	Scanner

**Operation/Procedure**

- 1) Press [EXECUTE] key.  
The scanner is shifted to the lock enable position and stopped.

# 7

<b>7-1</b>	
<b>Purpose</b>	Setting
<b>Function (Purpose)</b>	Used to set the operating conditions of aging.
<b>Section</b>	Others

**Operation/Procedure**

- 1) Select an item to be set with the touch panel key.
- 2) Press [EXECUTE] key.

The machine is rebooted in the aging mode.  
The aging operation condition set by this mode is maintained hereafter unless the power is turned off or the setting is changed.

AGING	Aging operation setup
INTERVAL	Intermittent operation setting
MISFEED DISABLE	JAM detection ignoring setting
FUSING DISABLE	Fusing unit ignoring setting
WARMUP DISABLE	Warming up ignoring setting
DV CHECK DISABLE	Developing unit ignoring setting
SHADING DISABLE	Shading correction operation omitting setting
CCD GAIN FREE	CCD gain adjustment omitting setting

7-6

<b>Purpose</b>	Setting
<b>Function (Purpose)</b>	Used to set the operating intermittent aging cycle.

**Section**

**Operation/Procedure**

- 1) Enter the intermittent aging operation cycle (unit: sec) with 10-key.
- 2) Press [OK] key.  
The time entered in procedure 1) is set.  
\* The interval time that can be set is 1 to 900 (sec).

The aging operation condition set by this mode is maintained hereafter unless the power is turned off or the setting is changed.

7-8

<b>Purpose</b>	Operation display
<b>Function (Purpose)</b>	Used to display the warm-up time.

**Section**

**Operation/Procedure**

Press [EXECUTE] key.  
Counting of the warm-up time is started and the time required for warm-up is displayed  
\* Interruption of counting by pressing [EXECUTE] key is inhibited.

7-9

<b>Purpose</b>	Operation test/check
<b>Function (Purpose)</b>	Color setting in the color copy test mode (Used to check the copy operation and the image quality for each color).

**Section**

**Operation/Procedure**

- 1) Select the copy color with the touch panel key.  
(Two or more colors can be selected.)  
The key of the selected color is highlighted.
  - 2) Press [EXECUTE] key.  
Copying is performed with the selected color.
- When [CLOSE] key is pressed, the display goes into the copy operation menu in the simulation mode.

K	Setup/cancel of black
C	Setup/cancel of cyan
M	Setup/cancel of magenta
Y	Setup/cancel of yellow

7-12

<b>Purpose</b>	Operation test/check
<b>Function (Purpose)</b>	The document reading number of sheets setting (for aging operation)

**Section**

**Operation/Procedure**

- 1) Set document reading quantity with 10-key.  
(Setting range:0 - 255)
  - 2) Press [OK] key. The set value is saved.
- The aging operation condition set by this mode is maintained hereafter unless the power is turned off or the setting is changed.

8

8-1

<b>Purpose</b>	Operation test/check/adjustment
<b>Function (Purpose)</b>	Used to check and adjust the operations of the developing voltage in each print mode and the control circuit. * When the middle speed is adjusted, the low speed are also adjusted simultaneously.

**Section**

Process (Developing)

**Operation/Procedure**

- 1) Select a speed with [MIDDLE] and [LOW] keys on the touch panel.
- 2) Select a target item to be adjusted with scroll keys.
- 3) Enter the setting value with 10-key. (The value specified on the label of the high voltage PWB must be entered.)  
\* When the  $\Delta$   $\nabla$  key is pressed, the setting value of each item can be changed with 1up (1down) collectively.
- 4) Press [EXECUTE] key.  
The set value is saved and the voltage entered with step 3) is output for 30 sec.  
When [EXECUTE] key is pressed, the output is terminated.

Item/Display (Mode)		Content	Adjustment range	Actual voltage
MIDDLE	A	MIDDLE SPEED DVB_K Developing bias voltage (Middle speed mode)	K 0 - 600	-450V ±5V
	B	MIDDLE SPEED DVB_C Developing bias voltage (Middle speed mode)	C 0 - 600	-450V ±5V
	C	MIDDLE SPEED DVB_M Developing bias voltage (Middle speed mode)	M 0 - 600	-450V ±5V
	D	MIDDLE SPEED DVB_Y Developing bias voltage (Middle speed mode)	Y 0 - 600	-450V ±5V
LOW	A	LOW SPEED DVB_K Developing bias voltage (Low speed mode)	K 0 - 600	-450V ±5V
	B	LOW SPEED DVB_C Developing bias voltage (Low speed mode)	C 0 - 600	-430V ±5V
	C	LOW SPEED DVB_M Developing bias voltage (Low speed mode)	M 0 - 600	-430V ±5V
	D	LOW SPEED DVB_Y Developing bias voltage (Low speed mode)	Y 0 - 600	-430V ±5V

8-2

<b>Purpose</b>	Operation test/check/adjustment
<b>Function (Purpose)</b>	Used to check and adjust the operation of the main charger grid voltage in each printer mode and the control circuit. * When the middle speed is adjusted, the low speed are also adjusted simultaneously.
<b>Section</b>	Process (Charging)

**Operation/Procedure**

- 1) Select a speed with [MIDDLE] and [LOW] keys on the touch panel.
- 2) Select a target item to be adjusted with scroll keys.
- 3) Enter the adjustment value with 10-key. (The value specified on the label of the high voltage PWB must be entered.)  
\* When the  $\Delta$   $\nabla$  key is pressed, the setting value of each item can be changed with 1up (1down) collectively.
- 4) Press [EXECUTE] key.  
The set value is saved and the voltage entered with step 3) is output for 30 sec.  
When [EXECUTE] key is pressed, the output is terminated.

Item/Display (Mode)		Content	Adjustment range	Actual voltage				
				18cpm/ 20cpm/ 23cpm machine	26cpm/ 31cpm machine	36cpm machine		
MIDDLE	A	MIDDLE SPEED GB_K	Main charger grid voltage (Middle speed mode)	K	150 - 850	-615V±5V	-620V±5V	-625V±5V
	B	MIDDLE SPEED GB_C	Main charger grid voltage (Middle speed mode)	C	150 - 850	-615V±5V	-620V±5V	-625V±5V
	C	MIDDLE SPEED GB_M	Main charger grid voltage (Middle speed mode)	M	150 - 850	-615V±5V	-620V±5V	-625V±5V
	D	MIDDLE SPEED GB_Y	Main charger grid voltage (Middle speed mode)	Y	150 - 850	-615V±5V	-620V±5V	-625V±5V
LOW	A	LOW SPEED GB_K	Main charger grid voltage (Low speed mode)	K	150 - 850	-610V±5V	-610V±5V	-610V±5V
	B	LOW SPEED GB_C	Main charger grid voltage (Low speed mode)	C	150 - 850	-590V±5V	-590V±5V	-590V±5V
	C	LOW SPEED GB_M	Main charger grid voltage (Low speed mode)	M	150 - 850	-590V±5V	-590V±5V	-590V±5V
	D	LOW SPEED GB_Y	Main charger grid voltage (Low speed mode)	Y	150 - 850	-590V±5V	-590V±5V	-590V±5V

8-6

<b>Purpose</b>	Operation test/check/adjustment
<b>Function (Purpose)</b>	Used to check and adjust the operation of the transport voltage and the control circuit.
<b>Section</b>	Process (Transport)

**Operation/Procedure**

- 1) Select a target item to be adjusted with scroll keys.
- 2) Enter the set value with 10-key.  
Enter the default value specified on the following list.
- 3) Press [EXECUTE] key.  
The set value is saved and the voltage corresponding to the set value is output for 30 sec.  
When [EXECUTE] key is pressed, the output is terminated.

Item/Display		Content				Setting range	18cpm/20cpm/23cpm machine		26cpm/31cpm machine		36cpm machine	
							Default value	Actual output value	Default value	Actual output value	Default value	Actual output value
A	TC1 LOW SPEED CL K	Primary transfer bias adjustment value	Color	K	Low speed	51 - 255	80	6 $\mu$ A	80	6 $\mu$ A	80	6 $\mu$ A
B	TC1 MIDDLE SPEED CL K				Middle speed	51 - 255	95	8 $\mu$ A	109	10 $\mu$ A	117	11 $\mu$ A
C	TC1 LOW SPEED CL C			C	Low speed	51 - 255	80	6 $\mu$ A	80	6 $\mu$ A	80	6 $\mu$ A
D	TC1 MIDDLE SPEED CL C				Middle speed	51 - 255	95	8 $\mu$ A	109	10 $\mu$ A	117	11 $\mu$ A
E	TC1 LOW SPEED CL M		M	Low speed	51 - 255	80	6 $\mu$ A	80	6 $\mu$ A	80	6 $\mu$ A	
F	TC1 MIDDLE SPEED CL M			Middle speed	51 - 255	95	8 $\mu$ A	109	10 $\mu$ A	117	11 $\mu$ A	
G	TC1 LOW SPEED CL Y		Y	Low speed	51 - 255	80	6 $\mu$ A	80	6 $\mu$ A	80	6 $\mu$ A	
H	TC1 MIDDLE SPEED CL Y			Middle speed	51 - 255	95	8 $\mu$ A	109	10 $\mu$ A	117	11 $\mu$ A	
I	TC1 LOW SPEED BW K	Black/White	K	Low speed	51 - 255	80	6 $\mu$ A	80	6 $\mu$ A	80	6 $\mu$ A	
J	TC1 MIDDLE SPEED BW K			Middle speed	51 - 255	95	8 $\mu$ A	109	10 $\mu$ A	117	11 $\mu$ A	
K	TC2 PLAIN CL SPX	Secondary transfer bias adjustment value	Color	Standard paper	Front surface	51 - 255	96	-35 $\mu$ A	103	-40 $\mu$ A	110	-45 $\mu$ A
L	TC2 PLAIN CL DPX				Back surface	51 - 255	76	-20 $\mu$ A	90	-30 $\mu$ A	96	-35 $\mu$ A
M	TC2 PLAIN BW SPX		Black/White		Front surface	51 - 255	96	-35 $\mu$ A	103	-40 $\mu$ A	110	-45 $\mu$ A
N	TC2 PLAIN BW DPX				Back surface	51 - 255	76	-20 $\mu$ A	90	-30 $\mu$ A	96	-35 $\mu$ A
O	TC2 HEAVY1 CL SPX		Color	Heavy paper 1	Front surface	51 - 255	83	-25 $\mu$ A	83	-25 $\mu$ A	83	-25 $\mu$ A
P	TC2 HEAVY1 CL DPX				Back surface	51 - 255	76	-20 $\mu$ A	76	-20 $\mu$ A	76	-20 $\mu$ A
Q	TC2 HEAVY1 BW SPX		Black/White		Front surface	51 - 255	69	-15 $\mu$ A	69	-15 $\mu$ A	69	-15 $\mu$ A
R	TC2 HEAVY1 BW DPX				Back surface	51 - 255	69	-15 $\mu$ A	69	-15 $\mu$ A	69	-15 $\mu$ A
S	TC2 HEAVY2 CL		Color	Heavy paper 2		51 - 255	83	-25 $\mu$ A	83	-25 $\mu$ A	83	-25 $\mu$ A
T	TC2 HEAVY2 BW			Black/White			51 - 255	69	-15 $\mu$ A	69	-15 $\mu$ A	69
U	TC2 OHP CL		Color	OHP		51 - 255	69	-15 $\mu$ A	69	-15 $\mu$ A	69	-15 $\mu$ A
V	TC2 OHP BW			Black/White			51 - 255	69	-15 $\mu$ A	69	-15 $\mu$ A	69
W	TC2 ENVELOPE CL		Color	Envelope		51 - 255	69	-15 $\mu$ A	69	-15 $\mu$ A	69	-15 $\mu$ A
X	TC2 ENVELOPE BW			Black/White			51 - 255	69	-15 $\mu$ A	69	-15 $\mu$ A	69
Y	TC2 THIN CL		Color	Thin paper		51 - 255	96	-35 $\mu$ A	103	-40 $\mu$ A	110	-45 $\mu$ A
Z	TC2 THIN BW			Black/White			51 - 255	96	-35 $\mu$ A	103	-40 $\mu$ A	110
AA	TC2 GLOSSY CL	Color	Gloss paper		51 - 255	83	-25 $\mu$ A	83	-25 $\mu$ A	83	-25 $\mu$ A	
AB	TC2 GLOSSY BW		Black/White			51 - 255	69	-15 $\mu$ A	69	-15 $\mu$ A	69	-15 $\mu$ A
AC	TC2 CLEANING	Secondary transfer cleaning bias adjustment value	Cleaning process (negative pole)			51 - 255	59	-8 $\mu$ A	59	-8 $\mu$ A	59	-8 $\mu$ A
AD	TC2 CLEAN LOW SPD		Low speed print mode			0 - 255	26	0V	26	0V	26	0V
AE	TC2 CLEAN MIDDLE SPD		Middle speed print mode			0 - 255	26	0V	26	0V	26	0V
AF	TC2 CLEAN CLEANING		Cleaning bias (positive pole)			0 - 255	102	500V	102	500V	102	500V
AG	PTC LOW SPEED CL	PTC current adjustment value	Color	Low speed	51 - 255	73	-200 $\mu$ A	73	-200 $\mu$ A	73	-200 $\mu$ A	
AH	PTC MIDDLE SPEED CL			Middle speed	51 - 255	73	-200 $\mu$ A	73	-200 $\mu$ A	73	-200 $\mu$ A	
AI	PTC LOW SPEED BW		Black/White	Low speed	51 - 255	73	-200 $\mu$ A	73	-200 $\mu$ A	73	-200 $\mu$ A	
AJ	PTC MIDDLE SPEED BW			Middle speed	51 - 255	73	-200 $\mu$ A	73	-200 $\mu$ A	73	-200 $\mu$ A	
AK	CASE VOLT LOW CL	PTC voltage adjustment value	Color	Low speed	0 - 255	0	0V	0	0V	0	0V	
AL	CASE VOLT MID CL			Middle speed	0 - 255	0	0V	0	0V	0	0V	
AM	CASE VOLT LOW BW		Black/White	Low speed	0 - 255	0	0V	0	0V	0	0V	
AN	CASE VOLT MID BW			Middle speed	0 - 255	0	0V	0	0V	0	0V	

## 9

9-2

<b>Purpose</b>	Operation test/check
<b>Function (Purpose)</b>	Used to check the operations of the sensors and detectors in the paper reverse section (duplex section) and its control circuit.
<b>Section</b>	Duplex

### Operation/Procedure

The operating conditions of the sensors and detectors are displayed.

The code names of the sensors and the detectors which are active are highlighted.

APPD1	ADU paper transport detector 1
APPD2	ADU paper transport detector 2
DSW_ADU	ADU paper guide open/close detector

9-3

<b>Purpose</b>	Operation test/check
<b>Function (Purpose)</b>	Used to check the operations of the load in the paper reverse section (duplex section) and its control circuit.
<b>Section</b>	Duplex

### Operation/Procedure

- 1) Select the item to be operation checked with the touch panel key.
- 2) Press [EXECUTE] key.  
The selected load performs the operation.  
When [EXECUTE] key is pressed, the operation is terminated.

### 18cpm/20cpm/23cpm/26cpm/31cpm machine

Display	Content
ADUM	ADU motor
ADUC1	ADU transport clutch 1 *1

\*1: Displayed, but not installed in some models.

### 36cpm machine

Display	Content
ADUC1	ADU transport clutch 1 (*)
ADUM	ADU motor
ADUGS	ADU gate solenoid

\*: Not used, but the button is displayed.

## 10

10-1

<b>Purpose</b>	Operation test/check
<b>Function (Purpose)</b>	Used to check the operations of the toner supply mechanism (toner motor) and the related circuit.
<b>Section</b>	Process (Developing)

### Operation/Procedure

- 1) Select a target of the operation check with the touch panel key.  
When [ALL] key is pressed, all the items are selected.
- 2) Press [EXECUTE] key.  
The selected load operation is performed for 10 sec.  
When [EXECUTE] key is pressed, the operation is terminated.

## Important

This simulation must be executed without installing the toner cartridges.

If this simulation is executed with the toner cartridges installed, toner will be forcibly supplied to the developing unit, resulting in overtoner.

If this simulation is erroneously executed with the toner cartridges installed, overtoner state may be deleted by making a few black background copy in the single color copy mode of the target color.

TNM_K	Toner motor K
TNM_C	Toner motor C
TNM_M	Toner motor M
TNM_Y	Toner motor Y

## 13

13--

<b>Purpose</b>	Cancel (Trouble etc.)
<b>Function (Purpose)</b>	Used to cancel the self-diag "U1" trouble.
<b>Section</b>	

### Operation/Procedure

- 1) Press [EXECUTE] key.
- 2) Press [YES] key to execute cancellation of the trouble.

## 14

14--

<b>Purpose</b>	Cancel (Trouble etc.)
<b>Function (Purpose)</b>	Used to cancel the self-diag H3, H4, H5 troubles.
<b>Section</b>	

### Operation/Procedure

- 1) Press [EXECUTE] key.
- 2) Press [YES] key to execute cancellation of the trouble.

## 15

15--

<b>Purpose</b>	Clear/Cancel (Trouble etc.)
<b>Function (Purpose)</b>	Used to cancel the self-diag "U6" trouble.
<b>Section</b>	LCC

### Operation/Procedure

- 1) Press [EXECUTE] key.
- 2) Press [YES] key to execute cancellation of the trouble.

## 16

16--	
<b>Purpose</b>	Clear/Cancel (Trouble etc.)
<b>Function (Purpose)</b>	Used to cancel the self-diag "U2" trouble.
<b>Section</b>	MFP PWB / PCU PWB / SCU PWB

### Operation/Procedure

- 1) Press [EXECUTE] key.
- 2) Press [YES] key to execute cancellation of the trouble.

## 17

17--	
<b>Purpose</b>	Clear/Cancel (Trouble etc.)
<b>Function (Purpose)</b>	Used to cancel the self-diag "PF" trouble.
<b>Section</b>	

### Operation/Procedure

- 1) Press [EXECUTE] key.
- 2) Press [YES] key to execute cancellation of the trouble.

## 21

21-1	
<b>Purpose</b>	Setting
<b>Function (Purpose)</b>	Used to set the maintenance cycle.
<b>Section</b>	

### Operation/Procedure

\* Do not change the default setting value of the maintenance counter on SIM21-1. The replacement timing of the fusing cleaning roller, the filter and PS paper dust removal cleaner may not clarify.

- 1) Select a target item of setting with scroll key on the touch panel.
- 2) Enter the set value with 10-key.
- 3) Press [OK] key. (The set value is saved.)

Item/Display	Content	Setting range	Default value			
			18cpm machine	20cpm/23cpm/26cpm/31cpm machine	36cpm machine	
A	MAINTENANCE COUNTER (TOTAL)	Maintenance counter (Total)	0: Default 1 – 300: 1K – 300K 999: Free	80K	100K	120K
B	MAINTENANCE COUNTER (COLOR)	Maintenance counter (Color)	0: Default 1 – 300: 1K – 300K 999: Free	50K	60K	70K

## 22

22-1	
<b>Purpose</b>	Adjustment/Setting/Operation data output/Check
<b>Function (Purpose)</b>	Used to check the print count value in each section and each operation mode. (Used to check the maintenance timing.)
<b>Section</b>	

### Operation/Procedure

Change the display page with scroll key on the touch panel.

Item	Display	Content	
Total output quantity	TOTAL OUT (BW)	Total output quantity of black and white	All prints including jams
	TOTAL OUT (COL)	Total output quantity of color	All prints including jams
Total use quantity	TOTAL (BW)	Total use quantity of black and white	Effective paper (including self print, excluding jams)
	TOTAL (COL)	Total use quantity of full color	Effective paper (including self print, excluding jams)
	TOTAL (2COL)	Total use quantity of 2-color	Effective paper (including self print, excluding jams)
	TOTAL (3COL)	Total use quantity of 3-color	Effective paper (including self print, excluding jams)
	TOTAL (SGL_COL)	Total use quantity of single color	Effective paper (including self print, excluding jams)
Copy	COPY (BW)	Black and white copy counter	Billing target (excluding self print)
	COPY (COL)	Full color copy counter	Billing target (excluding self print)
	COPY (2COL)	2-color copy counter	Billing target (excluding self print)
	COPY (SGL_COL)	Single color copy counter	Billing target (excluding self print)
Print	PRINT (BW)	Black and white print counter	Billing target (excluding self print)
	PRINT (COL)	Full color print counter	Billing target (excluding self print)
	PRINT (2COL)	2-color print counter	Billing target (excluding self print)
	PRINT (3COL)	3-color print counter	Billing target (excluding self print)
	PRINT (SGL_COL)	Single color print counter	Billing target (excluding self print)
Document filing	DOC FIL (BW)	Black and white document filing print counter	Billing target (excluding self print)
	DOC FIL (COL)	Color document filing print counter	Billing target (excluding self print)
	DOC FIL (2COL)	2-color document filing print counter	Billing target (excluding self print)
	DOC FIL(SGL COL)	Single color document filing print counter	Billing target (excluding self print)
Other	OTHER (BW)	Black and white other counter	Self print quantity
	OTHER (COL)	Color other counter	Self print quantity
PCI	PCI OPE-TIME	PCI counter	PCI accumulated operation time (H)

**22-2**

<b>Purpose</b>	Adjustment/Setting/Operation data check
<b>Function (Purpose)</b>	Used to check the total number of misfeed and troubles. (When the number of total jam is considerably great, it is judged as necessary for repair.)

**Section****Operation/Procedure**

The paper jam, trouble counter value is displayed.

MACHINE JAM	Machine JAM counter
RSPF JAM	RSPF JAM counter
TROUBLE	Trouble counter

**22-3**

<b>Purpose</b>	Adjustment/Setting/Operation data check
<b>Function (Purpose)</b>	Used to check misfeed positions and the misfeed count of each position. * Presumption of the faulty point by this data is possible.

**Section****Operation/Procedure**

The paper jam and misfeed history is displayed from the latest one up to 50 items. (The old ones are deleted sequentially.)

**22-4**

<b>Purpose</b>	Adjustment/Setting/Operation data check
<b>Function (Purpose)</b>	Used to check the trouble (self diag) history.

**Section****Operation/Procedure**

The trouble history is displayed from the latest one up to 30 items. (The old ones are deleted sequentially.)

**22-5**

<b>Purpose</b>	Others
<b>Function (Purpose)</b>	Used to check the ROM version of each unit (section).

**Section**

Firmware

**Operation/Procedure**

The ROM version of the installed unit in each section is displayed. When there is any trouble in the software, use this simulation to check the ROM version, and upgrade the version if necessary.

**18cpm/20cpm/23cpm/31cpm(G) machine**

S/N	Serial No. (The codes for November and December are "X" and "Y" respectively.)
ICU (MAIN)	ICU (Main section)
ICU (BOOT)	ICU (Boot section)
ICU (SUB)	ICU (Sub section) (ARM9)
LANGUAGE	Language support data version
GRAPHIC	Graphic data for LCD
PCL (MAIN)	PCL (Main section)
PCL (PROFILE)	PCL (Color profile)
PCU	PCU
SCU	SCU
FAX1 (MAIN)	FAX 1-Line (Main section)
DESK	Desk unit
FINISHER	Finisher
NIC	NIC
POWER-CON	Power controller

E-MANUAL	Operation manual (HDD storage) (except 20cpm machine)
WATER MARK	Watermark (HDD storage)
ESCP	ESCP font ROM
PDL	PDL font ROM
PCI	PCI

**26cpm/36cpm/31cpm(A) machine**

S/N	Serial No. (The codes for November and December are "X" and "Y" respectively.)
UICONTENTS	Content data for display
ICU (MAIN)	ICU (Main section)
ICU (BOOT)	ICU (Boot section)
ICU (SUB)	ICU (Sub section) (ARM9)
LANGUAGE	Language support data version
GRAPHIC	Graphic data for LCD
PCL (MAIN)	PCL (Main section)
PCL (PROFILE)	PCL (Color profile)
PCU	PCU
SCU	SCU
FAX1 (MAIN)	FAX 1-Line (Main section)
DESK	Desk unit
LCC	LCC
FINISHER	Finisher
PUNCH	Punch module
NIC	NIC
POWER-CON	Power controller
E-MANUAL	Operation manual (HDD storage)
WATER MARK	Watermark (HDD storage)
ESCP	ESCP font ROM
ACRE (MAIN)	Enhanced compression kit (Main section)
ACRE (DATA)	Enhanced compression kit (Data section)
PCI	PCI

**22-6**

<b>Purpose</b>	Adjustment/Setting/Operation data check
<b>Function (Purpose)</b>	Used to output the setting/adjustment data (simulation, FAX soft switch, counter), the firmware version, and the counter list.

**Section****Operation/Procedure**

\* When installing or servicing, this simulation is executed to print the adjustment data and set data for use in the next servicing. (Memory trouble, PWB replacement, etc.)

- 1) Select the print list mode with 10-key.

Item/Display	Print list mode	Print content	
A	DATA PATTERN	1	Firmware version, counter data, etc.
		2	SIM50-24 data
		3	Data related to the process control

- 2) Press [EXECUTE] key to start printing the list selected in step 1).



22-8

<b>Purpose</b>	Adjustment/Setting/Operation data check
<b>Function (Purpose)</b>	Used to check the number of operations (counter value) of the finisher, the RSPF, and the scan (reading) unit.

**Section**

**Operation/Procedure**

The counter values of the finisher, the RSPF, and the scanner related counters are displayed.

SPF	Document feed quantity (The number of sheets of discharged documents)
SCAN	Number of times of scan
STAPLER	Staple counter
PUNCHER	Puncher counter
STAMP	Stamp counter
COVER	Document cover open/close counter
HP_ON	Number of scanner HP detection
OC LAMP TIME	Total lighting time of the scanner lamp (* hour * minutes)
SADDLE STAPLER	Saddle staple counter (26cpm/36cpm/31cpm(A) machine only)
SADDLE V FOLD	Saddle finisher V fold counter (26cpm/36cpm/31cpm(A) machine only)

22-9

<b>Purpose</b>	Adjustment/Setting/Operation data check
<b>Function (Purpose)</b>	Used to check the number of use (print quantity) of each paper feed section.

**Section**

Paper feed, ADU, LCC

**Operation/Procedure**

The counter values related to paper feed are displayed.

TRAY1	Paper feed counter (Paper feed tray 1)
TRAY2	Paper feed counter (Paper feed tray 2)
TRAY3	Paper feed counter (Paper feed tray 3)
TRAY4	Paper feed counter (Paper feed tray 4)
MFT TOTAL	Manual paper feed counter (Total)
MFT HEAVY	Manual paper feed counter (Heavy paper)
MFT OHP	Manual paper feed counter (OHP)
MFT ENV	Manual paper feed counter (Envelope)
ADU	ADU paper transport counter (Paper reverse section)
LCC	Side LCC paper feed counter (LCC) (26cpm/36cpm/31cpm(A) machine only)

22-10

<b>Purpose</b>	Adjustment/Setting/Operation data check
<b>Function (Purpose)</b>	Used to check the system configuration (option, internal hardware).

**Section**

**Operation/Procedure**

The system configuration is displayed.

(The model names of the installed devices and options are displayed.)

MACHINE	MX-1810U	Main unit
	MX-2010U	
	MX-2310U	
	MX-2610N	
	MX-3111U	
	MX-3610N	
SPF	MX-RP12	Reversing single pass feeder
	STANDARD	
STAMP	AR-SU1	Finish stamp
DESK	MX-DE12	Stand/1x500 sheet paper drawer
	MX-DE13	Stand/2x500 sheet paper drawer
	MX-DE14	Stand/3x500 sheet paper drawer
LCC	MX-LC11	Large capacity tray (Side LCC)
PUNCHER	MX-PN11A	Punch unit
	MX-PN11B	
	MX-PN11C	
	MX-PN11D	
	MX-PNX5A	
	MX-PNX5B	
	MX-PNX5C	
FINISHER	MX-FN17	Inner finisher
	MX-FN10	Saddle stitch finisher (1K)
FAX1	MX-FX11	Facsimile expansion kit
PRINTER	MX-PB14	Printer expansion kit (PCL)
PS	MX-PK11	PS expansion kit
XPS	MX-PUX1	XPS expansion kit
SECURITY	MX-FR25U	Data security kit (commercial version)
	MX-FR30U	Data security kit (commercial version)
	MX-FR34U	Data security kit (commercial version)
AIM	MX-AMX1	Application integration module
SDRAM (SYS)	****MB	SDRAM capacity
SDRAM (ICU)	****MB	SDRAM capacity
HDD	****MB	Hard disk capacity
SD	****MB	SD Card capacity
NIC	STANDARD	NIC
BARCODE	MX-PF10	Bar code font
INTERNET-FAX	MX-FWX1	Internet Fax expansion kit
ACM(*)	MX-AMX2	Application communication module
EAM(*)	MX-AMX3	External account module
WEB BROWSING	MX-AM10	Web browsing expansion kit
ACRE	MX-EB11	Enhanced compression kit (ACRE)
MIRRORING	MX-EB12	Mirroring kit
PCI	NOTE	PCI generating unit
	CONNECT	

(\*) Displayed only in the OSA models.

22-11

<b>Purpose</b>	Adjustment/Setting/Operation data check
<b>Function (Purpose)</b>	Used to check the use frequency (send/receive) of FAX. (Only when FAX is installed)

**Section** FAX

**Operation/Procedure**

The values of the FAX send counter and the FAX receive counter are displayed.

FAX OUTPUT	FAX print quantity counter (for line 1)
FAX SEND	FAX send counter
FAX RECEIVED	FAX receive counter
SEND IMAGES	FAX send quantity counter (for line 1)
SEND TIME	FAX send time
RECEIVED TIME	FAX receive time

22-12

<b>Purpose</b>	Adjustment/Setting/Operation data check
<b>Function (Purpose)</b>	Used to check the RSPF misfeed positions and the number of misfeed at each position. (When the number of misfeed is considerably great, it can be judged as necessary for repair.)
<b>Section</b>	RSPF

**Operation/Procedure**

The paper jam and misfeed history is displayed from the latest one up to 50 items. (The old ones are deleted sequentially.)

22-13

<b>Purpose</b>	Adjustment/Setting/Operation data check
<b>Function (Purpose)</b>	Used to check the operating time of the process section (OPC drum, DV unit, toner cartridge) and the fusing unit
<b>Section</b>	Process

**Operation/Procedure**

The number of prints and the number of rotations in the process section are displayed.

**18cpm/20cpm/23cpm/26cpm/31cpm machine**

Item/Display	Content	Print counter	RPM	Number of use days	Life meter	Number of remaining days
MAINTENANCE ALL	Maintenance counter (Total) (Counter)	Max. 8	Not displayed	0 - 999	0 - 100 (%)	0 - 365
MAINTENANCE COL	Maintenance counter (Color)	Max. 8	Not displayed	0 - 999	0 - 100 (%)	0 - 365
FUSING BELT	Fusing belt (23cpm/26cpm/31cpm machine only)	Max. 8	Max. 8	0 - 999	0 - 100 (%)	0 - 365
HEAT ROLLER	Heat roller (20cpm model)	Max. 8	Max. 8	0 - 999	0 - 100 (%)	0 - 365
FUSING ROLLER	Fusing roller	Max. 8	Max. 8	0 - 999	0 - 100 (%)	0 - 365
PRESSURE ROLLER	Fusing pressure roller	Max. 8	Max. 8	0 - 999	0 - 100 (%)	0 - 365
SEPARATE PAWL	Fusing separation pawl	Max. 8	Max. 8	0 - 999	0 - 100 (%)	0 - 365
SEPARATE PLATE	Fusing separation plate	Max. 8	Max. 8	0 - 999	0 - 100 (%)	0 - 365
CLEANING ROLLER	Fusing cleaning roller	Max. 8	Max. 8	0 - 999	0 - 100 (%)	0 - 365
TC1 BELT	Primary transfer belt	Max. 8	Max. 8	0 - 999	0 - 100 (%)	0 - 365
TRANSFER BLADE	Transfer cleaning blade	Max. 8	Max. 8	0 - 999	0 - 100 (%)	0 - 365
PTC	PTC	Max. 8	Max. 8	0 - 999	0 - 100 (%)	0 - 365
TC2 BELT	Secondary transfer belt	Max. 8	Max. 8	0 - 999	0 - 100 (%)	0 - 365
PS PAPER	Paper dust cleaner	Max. 8	Not displayed	0 - 999	0 - 100 (%)	0 - 365
OZONE FILTER	Ozone filter	Max. 8	Not displayed	0 - 999	0 - 100 (%)	0 - 365
DEVE CTRG (K)	DV unit (K)	Max. 8	Max. 8	0 - 999	0 - 100 (%)	0 - 365
DEVE CTRG (C)	DV unit (C)	Max. 8	Max. 8	0 - 999	0 - 100 (%)	0 - 365
DEVE CTRG (M)	DV unit (M)	Max. 8	Max. 8	0 - 999	0 - 100 (%)	0 - 365
DEVE CTRG (Y)	DV unit (Y)	Max. 8	Max. 8	0 - 999	0 - 100 (%)	0 - 365
DRUM CTRG (K)	OPC drum unit (K)	Max. 8	Max. 8	0 - 999	0 - 100 (%)	0 - 365
DRUM CTRG (C)	OPC drum unit (C)	Max. 8	Max. 8	0 - 999	0 - 100 (%)	0 - 365
DRUM CTRG (M)	OPC drum unit (M)	Max. 8	Max. 8	0 - 999	0 - 100 (%)	0 - 365
DRUM CTRG (Y)	OPC drum unit (Y)	Max. 8	Max. 8	0 - 999	0 - 100 (%)	0 - 365
MAIN CHARGER (K)	Main charger (K)	Max. 8	Max. 8	0 - 999	0 - 100 (%)	0 - 365
MAIN CHARGER (C)	Main charger (C)	Max. 8	Max. 8	0 - 999	0 - 100 (%)	0 - 365
MAIN CHARGER (M)	Main charger (M)	Max. 8	Max. 8	0 - 999	0 - 100 (%)	0 - 365
MAIN CHARGER (Y)	Main charger (Y)	Max. 8	Max. 8	0 - 999	0 - 100 (%)	0 - 365
DRUM BLADE (K)	OPC drum cleaning blade K	Max. 8	Max. 8	0 - 999	0 - 100 (%)	0 - 365
DRUM BLADE (C)	OPC drum cleaning blade C	Max. 8	Max. 8	0 - 999	0 - 100 (%)	0 - 365
DRUM BLADE (M)	OPC drum cleaning blade M	Max. 8	Max. 8	0 - 999	0 - 100 (%)	0 - 365
DRUM BLADE (Y)	OPC drum cleaning blade Y	Max. 8	Max. 8	0 - 999	0 - 100 (%)	0 - 365
TONER CTRG (K)	Toner cartridge (K)	Max. 8	Max. 8	0 - 999	0 - 100 (%)	Not displayed
TONER CTRG (C)	Toner cartridge (C)	Max. 8	Max. 8	0 - 999	0 - 100 (%)	Not displayed
TONER CTRG (M)	Toner cartridge (M)	Max. 8	Max. 8	0 - 999	0 - 100 (%)	Not displayed
TONER CTRG (Y)	Toner cartridge (Y)	Max. 8	Max. 8	0 - 999	0 - 100 (%)	Not displayed

36cpm machine

Item/Display	Content	Print counter	RPM	Number of use days	Life meter	Number of remaining days
MAINTENANCE ALL	Maintenance counter (Total) (Counter)	Max. 8	Not displayed	0 - 999	0 - 100 (%)	0 - 365
MAINTENANCE COL	Maintenance counter (Color)	Max. 8	Not displayed	0 - 999	0 - 100 (%)	0 - 365
FUSING BELT	Fusing belt	Max. 8	Max. 8	0 - 999	0 - 100 (%)	0 - 365
FUSING ROLLER	Fusing roller	Max. 8	Max. 8	0 - 999	0 - 100 (%)	0 - 365
PRESSURE ROLLER	Fusing pressure roller	Max. 8	Max. 8	0 - 999	0 - 100 (%)	0 - 365
SEPARATE PAWL	Fusing separation pawl	Max. 8	Max. 8	0 - 999	0 - 100 (%)	0 - 365
SEPARATE PLATE	Fusing separation plate	Max. 8	Max. 8	0 - 999	0 - 100 (%)	0 - 365
FUSING WEB UNIT	Fusing web unit	Max. 8	Not displayed	0 - 999	0 - 100 (%)	0 - 365
FUSING WEB SEND	Fusing web cleaning send counter	0 - 65535	Not displayed	Not displayed	Not displayed	Not displayed
TC1 BELT	Primary transfer belt	Max. 8	Max. 8	0 - 999	0 - 100 (%)	0 - 365
TRANSFER BLADE	Transfer cleaning blade	Max. 8	Max. 8	0 - 999	0 - 100 (%)	0 - 365
PTC	PTC	Max. 8	Max. 8	0 - 999	0 - 100 (%)	0 - 365
TC2 BELT	Secondary transfer belt	Max. 8	Max. 8	0 - 999	0 - 100 (%)	0 - 365
PS PAPER	Paper dust cleaner	Max. 8	Not displayed	0 - 999	0 - 100 (%)	0 - 365
OZONE FILTER	Ozone filter	Max. 8	Not displayed	0 - 999	0 - 100 (%)	0 - 365
DEVE CTRG (K)	DV unit (K)	Max. 8	Max. 8	0 - 999	0 - 100 (%)	0 - 365
DEVE CTRG (C)	DV unit (C)	Max. 8	Max. 8	0 - 999	0 - 100 (%)	0 - 365
DEVE CTRG (M)	DV unit (M)	Max. 8	Max. 8	0 - 999	0 - 100 (%)	0 - 365
DEVE CTRG (Y)	DV unit (Y)	Max. 8	Max. 8	0 - 999	0 - 100 (%)	0 - 365
DRUM CTRG (K)	OPC drum unit (K)	Max. 8	Max. 8	0 - 999	0 - 100 (%)	0 - 365
DRUM CTRG (C)	OPC drum unit (C)	Max. 8	Max. 8	0 - 999	0 - 100 (%)	0 - 365
DRUM CTRG (M)	OPC drum unit (M)	Max. 8	Max. 8	0 - 999	0 - 100 (%)	0 - 365
DRUM CTRG (Y)	OPC drum unit (Y)	Max. 8	Max. 8	0 - 999	0 - 100 (%)	0 - 365
MAIN CHARGER (K)	Main charger (K)	Max. 8	Max. 8	0 - 999	0 - 100 (%)	0 - 365
MAIN CHARGER (C)	Main charger (C)	Max. 8	Max. 8	0 - 999	0 - 100 (%)	0 - 365
MAIN CHARGER (M)	Main charger (M)	Max. 8	Max. 8	0 - 999	0 - 100 (%)	0 - 365
MAIN CHARGER (Y)	Main charger (Y)	Max. 8	Max. 8	0 - 999	0 - 100 (%)	0 - 365
DRUM BLADE (K)	OPC drum cleaning blade K	Max. 8	Max. 8	0 - 999	0 - 100 (%)	0 - 365
DRUM BLADE (C)	OPC drum cleaning blade C	Max. 8	Max. 8	0 - 999	0 - 100 (%)	0 - 365
DRUM BLADE (M)	OPC drum cleaning blade M	Max. 8	Max. 8	0 - 999	0 - 100 (%)	0 - 365
DRUM BLADE (Y)	OPC drum cleaning blade Y	Max. 8	Max. 8	0 - 999	0 - 100 (%)	0 - 365
TONER CTRG (K)	Toner cartridge (K)	Max. 8	Max. 8	0 - 999	0 - 100 (%)	Not displayed
TONER CTRG (C)	Toner cartridge (C)	Max. 8	Max. 8	0 - 999	0 - 100 (%)	Not displayed
TONER CTRG (M)	Toner cartridge (M)	Max. 8	Max. 8	0 - 999	0 - 100 (%)	Not displayed
TONER CTRG (Y)	Toner cartridge (Y)	Max. 8	Max. 8	0 - 999	0 - 100 (%)	Not displayed

22-14

<b>Purpose</b>	Adjustment/Setting/Operation data check
<b>Function (Purpose)</b>	Used to display the use status of the toner cartridge.
<b>Section</b>	Process

**Operation/Procedure**

The status of the toner cartridge is displayed.

Display item	Content	Accumulated No. of installed cartridges (Unit)	Accumulated No. of near near end (Unit)	Accumulated No. of end (Unit)	Remaining quantity (Unit: %)
		INSTALL	NN END	END	RESIDUAL
TONER (K)	Toner cartridge use counter (K)	0 - 255	0 - 255	0 - 255	0-25%
TONER (C)	Toner cartridge use counter (C)				25-50%
TONER (M)	Toner cartridge use counter (M)				50-75%
TONER (Y)	Toner cartridge use counter (Y)				75-100%

<b>22-18</b>	
<b>Purpose</b>	Adjustment/Setting/Operation data check
<b>Function (Purpose)</b>	Used to display the user data delete history.
<b>Section</b>	

**Operation/Procedure**

The date and time of the user data delete are displayed.

Display item		Content
Item name	Date	
START	Year/month/day/hour/min.	Delete history (Date and time of operation start)
END	Year/month/day/hour/min.	Delete history (Date and time of operation end)

<b>22-19</b>	
<b>Purpose</b>	Adjustment/Setting/Operation data check
<b>Function (Purpose)</b>	Used to check the values of the counters related to the scan - image send.
<b>Section</b>	

**Operation/Procedure**

Used to display the counter value related to the network scanner  
Change the display with scroll key.

Item/Display	Content	
Network scanner	NET SCN ORG_B/W	Network scanner document read quantity counter (B/W scan job)
	NET SCN ORG_CL	Network scanner document read quantity counter (Color scan job)
	NET SCN ORG_2CL	Network scanner document read quantity counter (2-Color scan job)
	NET SCN ORG_SGL	Network scanner document read quantity counter (Single-color scan job)
Internet FAX	INTERNET FAX OUTPUT	Number of internet FAX output
	INTERNET FAX SEND OUTPUT	Number of internet FAX sending page
	INTERNET FAX RECEIVE	Number of internet FAX receive
	INTERNET FAX SEND	Number of internet FAX send
E-Mail	MAIL COUNTER	Number of times of E-MAIL send
FTP	FTP COUNTER	Number of FTP send
Other	SMB SEND	Number of SMB send
	USB CNT	Number of times of USB storage
	TRIAL MODE_B&C	Trial mode counter (B/W & COLOR scan job)
	SCAN TO HDD_B/W	SCAN TO HDD record quantity (B/W)
	SCAN TO HDD_CL	SCAN TO HDD record quantity (COLOR)
	SCAN TO HDD_2CL	SCAN TO HDD record quantity (2-COLOR)
	SCAN TO HDD_SGL	SCAN TO HDD record quantity (SINGLE color)

<b>22-40</b>	
<b>Purpose</b>	Error contents display
<b>Function (Purpose)</b>	Used to display the error code list and the contents.
<b>Section</b>	

**Operation/Procedure**

- 1) Select the main error code.

The sub error code and the contents are displayed.

<b>22-90</b>	
<b>Purpose</b>	Adjustment/Setting/Operation data check
<b>Function (Purpose)</b>	Used to output the various set data lists.
<b>Section</b>	

**Operation/Procedure**

- 1) Change the display with scroll key.
- 2) Select the print target with the keys on the touch panel.
- 3) Press [EXECUTE] key to start self print of the list.

All setting list (*)	ALL CUSTOM SETTING LIST
Printer test page	PCL SYMBOL SET LIST
	PCL INTERNAL FONT LIST
	PCL EXTENDED FONT LIST
	PS FONT LIST
	PS KANJI FONT LIST (Japan)
	PS EXTENDED FONT LIST
	NIC PAGE
Address registration list (*)	INDIVIDUAL LIST
	GROUP LIST
	PROGRAM LIST (Output Disable)
	MEMORY BOX LIST
	ALL SENDING ADDRESS LIST
Document filing list (*)	DOCUMENT FILING FOLDER LIST
System setting list	ADMIN. SETTINGS LIST (COPY)
	ADMIN. SETTINGS LIST (PRINT)
	ADMIN. SETTINGS LIST (IMAGE SEND)
	ADMIN. SETTINGS LIST (DOC FILING)
	ADMIN. SETTINGS LIST (SECURITY)
	ADMIN. SETTINGS LIST (COMMON)
	ALL ADMINISTRATOR SETTINGS LIST
Receive rejection number table	ANTI JUNK FAX NUMBER LIST
Receive rejection/allow address domain table	ANTI JUNK MAIL/DOMAIN NAME LIST
To E-mail Transfer table list	INBOUND ROUTING LIST
To administrator Transfer list	DOCUMENT ADMIN LIST
Web setting list	WEB SETTING LIST
Meta data set list	METADATA SET LIST

\* When the data list print of system setting is inhibition in DSK model, this setting is invalid.

<b>23</b>	
<b>23-2</b>	
<b>Purpose</b>	Adjustment/Setting/Operation data check

**Function (Purpose)** Used to output the trouble history list of paper jam and misfeed. (If the number of troubles of misfeed is considerably great, the judgment is made that repair is required.)

**Section**

**Operation/Procedure**

Press [EXECUTE] key to execute print.

The trouble history of paper jams and misfeed is printed.

23-80

<b>Purpose</b>	Operation test/check
<b>Function (Purpose)</b>	Used to check the operation of paper feed and paper transport in the paper feed section and the paper transport section. Used to output the list of the operation status of the sensor and the detectors in the paper feed section and the paper transport section.
<b>Section</b>	Paper feed, Paper transport

**Operation/Procedure**

When [EXECUTE] key is pressed, the timing list of paper feed and paper transport is outputted.

Used to print the operations timing list of the sensors and detectors in the paper feed and transport section.

The timing list of paper feed and paper transport operations of the latest job (copy or print) on the final paper is printed.

Since the paper feed and paper transport routes differ depending on the used paper feed tray and the print operation mode, the sensor and the detectors and the operation timing also differ.

SECTION	Operation content (Trigger name - Detection operation or load operation name)
STANDARD	Reference value (ms)
CURRENT (*1)	Operation timing (ms) of the latest job on the final paper
PREVIOUS (*1)	Operation timing (ms) of the second latest job on the final paper
MAXIMUM (*1)	Max. operation timing (ms) of all the jobs
MINIMUM (*1)	Min. operation timing (ms) of all the jobs

\*1: The value without unit on the left side of each item on the list has no relation to the operation timing. It is not used in the market.

**24**

24-1

<b>Purpose</b>	Data clear
<b>Function (Purpose)</b>	Used to clear the jam counter, and the trouble counter. (After completion of maintenance, clear the counters.)

**Section****Operation/Procedure**

- 1) Select the item to be cleared with the touch panel key.
- 2) Press [EXECUTE] key.
- 3) Press [YES] key.

The target counter is cleared.

MACHINE	Machine JAM counter
SPF	RSPF JAM counter
TROUBLE	Trouble counter

24-2

<b>Purpose</b>	Data clear
<b>Function (Purpose)</b>	Used to clear the number of use (the number of prints) of each paper feed section.
<b>Section</b>	

**Operation/Procedure**

- 1) Select the item to be cleared with the touch panel key.
- 2) Press [EXECUTE] key.
- 3) Press [YES] key.

The target counter is cleared.

TRAY1	Tray 1 paper feed counter
TRAY2	Tray 2 paper feed counter
TRAY3	Tray 3 paper feed counter
TRAY4	Tray 4 paper feed counter
MFT TOTAL	Manual paper feed counter (Total)
MFT HEAVY	Manual paper feed counter (Heavy paper)
MFT OHP	Manual paper feed counter (OHP)
MFT ENV	Manual paper feed counter (Envelope)
LCC	LCC paper feed counter (LCC)
ADU	ADU paper feed counter

24-3

<b>Purpose</b>	Data clear
<b>Function (Purpose)</b>	Used to clear the finisher, RSPF, and the scan (reading) unit counter.

**Section****Operation/Procedure**

- 1) Select the item to be cleared with the touch panel key.
- 2) Press [EXECUTE] key.
- 3) Press [YES] key.

The target counter is cleared.

SPF	RSPF document feed counter (No. of discharged sheets)
SCAN	Scan counter
STAPLER	Staple counter
PUNCHER	Puncher counter
STAMP	Stamp counter
SADDLE STAPLER	Saddle staple counter
SADDLE V FOLD	Saddle finisher V fold counter
COVER	Document cover open/close counter
HP_ON	Number of scanner HP detection
OC LAMP TIME	Total lighting time of the scanner lamp

24-4

<b>Purpose</b>	Data clear
<b>Function (Purpose)</b>	Used to clear the maintenance counter, the printer counters of the transport unit and the fusing unit. (After completion of maintenance, clear the counters.)

**Section****Operation/Procedure**

- 1) Select the item to be cleared with the touch panel key.
- 2) Press [EXECUTE] key.
- 3) Press [YES] key.

The target counter is cleared.

**18cpm/20cpm/23cpm/26cpm/31cpm machine**

Item/Display		Content
Maintenance	MAINTENANCE ALL	Maintenance counter (Total) (Counter) Maintenance counter (Total) (Number of use days)
	MAINTENANCE COL	Maintenance counter (Color) (Counter) Maintenance counter (Color) (Number of use days)
Fusing	FUSING BELT (23cpm/26cpm/31cpm machine only)	Fusing belt (Counter)
		Fusing belt (Number of use days)
		Fusing belt (Accumulated number of rotations)
	HEAT ROLLER (20cpm model)	Heat roller (Counter)
		Heat roller (Number of use days)
		Heat roller (Accumulated number of rotations)
	FUSING ROLLER	Fusing roller (Counter)
		Fusing roller (Number of use days)
		Fusing roller (Accumulated number of rotations)
	PRESS ROLLER	Pressure roller (Counter)
Pressure roller (Number of use days)		
Pressure roller (Accumulated number of rotations)		
Separation	SEPARATE PAWL	Separation pawl (Counter)
		Separation pawl (Number of use days)
		Separation pawl (Accumulated number of rotations)
	SEPARATE PLATE	Separation plate (Counter)
		Separation plate (Number of use days)
		Separation plate (Accumulated number of rotations)
	CLEAN ROLLER	Cleaning roller (Counter)
		Cleaning roller (Number of use days)
		Cleaning roller (Accumulated number of rotations)
Transfer	TC1 BELT	Primary transfer belt (Counter)
		Primary transfer belt (Number of use days)
		Primary transfer belt (Accumulated number of rotations)
	TRANS BLADE	Transfer blade (Counter)
		Transfer blade (Number of use days)
		Transfer blade (Accumulated number of rotations)
	TC2 BELT	Secondary transfer belt (Counter)
		Secondary transfer belt (Number of use days)
		Secondary transfer belt (Accumulated number of rotations)
	PTC	PTC counter (Counter)
PTC counter (Number of use days)		
PTC counter (Accumulated number of rotations)		
Drum	DRUM CTRG K	Drum cartridge (K) (Counter)
		Drum cartridge (K) (Number of use days)
		Drum cartridge (K) (Accumulated number of rotations)
	DRUM CTRG C	Drum cartridge (C) (Counter)
		Drum cartridge (C) (Number of use days)
		Drum cartridge (C) (Accumulated number of rotations)
	DRUM CTRG M	Drum cartridge (M) (Counter)
		Drum cartridge (M) (Number of use days)
		Drum cartridge (M) (Accumulated number of rotations)
	DRUM CTRG Y	Drum cartridge (Y) (Counter)
		Drum cartridge (Y) (Number of use days)
		Drum cartridge (Y) (Accumulated number of rotations)

Item/Display		Content
Main charger	MAIN CHARGER K	Main charger (K) (Counter)
		Main charger (K) (Number of use days)
		Main charger (K) (Accumulated number of rotations)
	MAIN CHARGER C	Main charger (C) (Counter)
		Main charger (C) (Number of use days)
		Main charger (C) (Accumulated number of rotations)
	MAIN CHARGER M	Main charger (M) (Counter)
		Main charger (M) (Number of use days)
		Main charger (M) (Accumulated number of rotations)
	MAIN CHARGER Y	Main charger (Y) (Counter)
		Main charger (Y) (Number of use days)
		Main charger (Y) (Accumulated number of rotations)
Drum blade	DRUM BLADE K	Drum blade K (Counter)
		Drum blade K (Number of use days)
		Drum blade K (Accumulated number of rotations)
	DRUM BLADE C	Drum blade C (Counter)
		Drum blade C (Number of use days)
		Drum blade C (Accumulated number of rotations)
	DRUM BLADE M	Drum blade M (Counter)
		Drum blade M (Number of use days)
		Drum blade M (Accumulated number of rotations)
	DRUM BLADE Y	Drum blade Y (Counter)
		Drum blade Y (Number of use days)
		Drum blade Y (Accumulated number of rotations)
Other	PS PAPER	PS paper dust cleaner (Counter)
		PS paper dust cleaner (Number of use days)
	OZONE FILTER	Ozone filter (Counter) Ozone filter (Number of use days)

**36cpm machine**

Item/Display		Content
Maintenance	MAINTENANCE ALL	Maintenance counter (Total) (Counter) Maintenance counter (Total) (Number of use days)
	MAINTENANCE COL	Maintenance counter (Color) (Counter) Maintenance counter (Color) (Number of use days)
Fusing	FUSING BELT	Fusing belt (Counter)
		Fusing belt (Number of use days)
		Fusing belt (Accumulated number of rotations)
	FUSING ROLLER	Fusing roller (Counter)
		Fusing roller (Number of use days)
		Fusing roller (Accumulated number of rotations)
	PRESS ROLLER	Pressure roller (Counter)
		Pressure roller (Number of use days)
		Pressure roller (Accumulated number of rotations)
Separation	SEPARATE PAWL	Separation pawl (Counter)
		Separation pawl (Number of use days)
		Separation pawl (Accumulated number of rotations)
	SEPARATE PLATE	Separation plate (Counter)
		Separation plate (Number of use days)
		Separation plate (Accumulated number of rotations)
FUSING WEB	Fusing web unit print counter	
	Use day of fusing web unit	
	Fusing web cleaning send counter	

Item/Display		Content
Transfer	TC1 BELT	Primary transfer belt (Counter)
		Primary transfer belt (Number of use days)
		Primary transfer belt (Accumulated number of rotations)
	TRANS BLADE	Transfer blade (Counter)
		Transfer blade (Number of use days)
		Transfer blade (Accumulated number of rotations)
	TC2 BELT	Secondary transfer belt (Counter)
		Secondary transfer belt (Number of use days)
		Secondary transfer belt (Accumulated number of rotations)
	PTC	PTC counter (Counter)
		PTC counter (Number of use days)
		PTC counter (Accumulated number of rotations)
Drum	DRUM CTRG K	Drum cartridge (K) (Counter)
		Drum cartridge (K) (Number of use days)
		Drum cartridge (K) (Accumulated number of rotations)
	DRUM CTRG C	Drum cartridge (C) (Counter)
		Drum cartridge (C) (Number of use days)
		Drum cartridge (C) (Accumulated number of rotations)
	DRUM CTRG M	Drum cartridge (M) (Counter)
		Drum cartridge (M) (Number of use days)
		Drum cartridge (M) (Accumulated number of rotations)
	DRUM CTRG Y	Drum cartridge (Y) (Counter)
		Drum cartridge (Y) (Number of use days)
		Drum cartridge (Y) (Accumulated number of rotations)
Main charger	MAIN CHARGER K	Main charger (K) (Counter)
		Main charger (K) (Number of use days)
		Main charger (K) (Accumulated number of rotations)
	MAIN CHARGER C	Main charger (C) (Counter)
		Main charger (C) (Number of use days)
		Main charger (C) (Accumulated number of rotations)
	MAIN CHARGER M	Main charger (M) (Counter)
		Main charger (M) (Number of use days)
		Main charger (M) (Accumulated number of rotations)
	MAIN CHARGER Y	Main charger (Y) (Counter)
		Main charger (Y) (Number of use days)
		Main charger (Y) (Accumulated number of rotations)
Drum blade	DRUM BLADE K	Drum blade K (Counter)
		Drum blade K (Number of use days)
		Drum blade K (Accumulated number of rotations)
	DRUM BLADE C	Drum blade C (Counter)
		Drum blade C (Number of use days)
		Drum blade C (Accumulated number of rotations)
	DRUM BLADE M	Drum blade M (Counter)
		Drum blade M (Number of use days)
		Drum blade M (Accumulated number of rotations)
	DRUM BLADE Y	Drum blade Y (Counter)
		Drum blade Y (Number of use days)
		Drum blade Y (Accumulated number of rotations)

Item/Display		Content
Other	PS PAPER	PS paper dust cleaner (Counter)
		PS paper dust cleaner (Number of use days)
	OZONE FILTER	Ozone filter (Counter)
		Ozone filter (Number of use days)

\* The winding counter for the fusing web cleaning is cleared by being synchronized with the fusing web cleaning feed counter.

24-5

<b>Purpose</b>	Data clear
<b>Function (Purpose)</b>	Used to clear the developer counter. (After replacement of developer, clear the counter.)

**Section**

#### Operation/Procedure

- 1) Select the item to be cleared with the touch panel key.
- 2) Press [EXECUTE] key.
- 3) Press [YES] key.

The target counter is cleared.

**Note**

When SIM25-2 is executed, this counter is also cleared automatically.

K	Developer cartridge print counter (K)
	Accumulated number of rotations of the developer cartridge (cm) (K)
	Number of day that used developer (Day) K
C	Developer cartridge print counter (C)
	Accumulated number of rotations of the developer cartridge (cm) (C)
	Number of day that used developer (Day) C
M	Developer cartridge print counter (M)
	Accumulated number of rotations of the developer cartridge (cm) (M)
	Number of day that used developer (Day) M
Y	Developer cartridge print counter (Y)
	Accumulated number of rotations of the developer cartridge (cm) (Y)
	Number of day that used developer (Day) Y

24-6

<b>Purpose</b>	Data clear
<b>Function (Purpose)</b>	Used to clear the copy counter.
<b>Section</b>	

#### Operation/Procedure

- 1) Select the item to be cleared with the touch panel key.
- 2) Press [EXECUTE] key.
- 3) Press [YES] key.

The target counter is cleared.

COPY BW	Copy counter (B/W)
COPY COL	Copy counter (COLOR)
SINGLE COLOR	Single color
2COLOR	2-color

**24-9**

**Purpose** Data clear

**Function (Purpose)** Used clear the printer mode print counter and the self print mode print counter.

**Section**

**Operation/Procedure**

- 1) Select the item to be cleared with the touch panel key.
- 2) Press [EXECUTE] key.
- 3) Press [YES] key.  
The target counter is cleared.

PRINT BW	Print counter (B/W)
PRINT COL	Print counter (COLOR)
PRINT (2COL)	Print counter (2-colors)
PRINT (3COL)	Print counter (3-colors)
PRINT (SGL_COL)	Print counter (Single color)
OTHER BW	Other counter (B/W)
OTHER COL	Other counter (COLOR)

**24-10**

**Purpose** Data clear

**Function (Purpose)** Used to clear the FAX counter. (Only when FAX is installed)

**Section**

**Operation/Procedure**

- 1) Select the item to be cleared with the touch panel key.
- 2) Press [EXECUTE] key.
- 3) Press [YES] key.  
The target counter is cleared.

FAX OUTPUT	FAX Print quantity counter
FAX SEND	FAX send counter
FAX RECEIVED	FAX receive counter
SEND IMAGES	FAX send quantity counter
SEND TIME	FAX send time
RECEIVED TIME	FAX receive time

**24-15**

**Purpose** Data clear

**Function (Purpose)** Used to clear the counters related to the scan mode and the image send.

**Section**

**Operation/Procedure**

- 1) Select the item to be cleared with the touch panel key.
- 2) Press [EXECUTE] key.
- 3) Press [YES] key.  
The target counter is cleared.

Division	Item/Display	Content
Network scanner	NET SCN ORG_B/W	Network scanner document read quantity counter (B/W scan job)
	NET SCN ORG_CL	Network scanner document read quantity counter (COLOR scan job)
	NET SCN ORG_2CL	Network scanner document read quantity counter (2-color scan job)
	NET SCN ORG_SGL	Network scanner document read quantity counter (single color scan job)

Division	Item/Display	Content
Internet Fax	INTERNET FAX OUTPUT	Number of internet FAX output
	INTERNET FAX SEND OUTPUT	Number of internet FAX sending page
	INTERNET FAX RECEIVE	Number of internet FAX receive
	INTERNET FAX SEND	Number of internet FAX send
E-mail	MAIL COUNTER	Number of times of E-MAIL send
FTP	FTP COUNTER	Number of FTP send
Other	SMB SEND	Number of SMB send
	USB CNT	Number of times of USB storage
	TRIAL MODE_B&C	Trial mode counter (B/W & COLOR scan job)
	SCAN TO HDD_B/W	SCAN TO HDD record quantity (B/W)
	SCAN TO HDD_CL	SCAN TO HDD record quantity (COLOR)
	SCAN TO HDD_2CL	SCAN TO HDD record quantity (2-COLOR)
SCAN TO HDD_SGL	SCAN TO HDD record quantity (SINGLE color)	

**24-35**

**Purpose** Data clear

**Function (Purpose)** Used to clear the toner cartridge use status data.

**Section**

**Operation/Procedure**

- 1) Press [EXECUTE] key.
- 2) Press [YES] key.  
The toner cartridge use status data (SIM22-14) are cleared.

**25**

**25-1**

**Purpose** Operation test/check

**Function (Purpose)** Used to check the operations of the developing section.

**Section**

Process (Developing section)

**Operation/Procedure**

- 1) Select the process speed with [MIDDLE], [LOW] keys.
- 2) Press [EXECUTE] key.  
The developing motor and the OPC drum motor rotate for 3 minutes and the output level of the toner density sensor is displayed.

TCS_K	Toner sensor output value (K)
TCS_C	Toner sensor output value (C)
TCS_M	Toner sensor output value (M)
TCS_Y	Toner sensor output value (Y)
TSG_K	Toner density sensor control voltage level (K)
TSG_C	Toner density sensor control voltage level (C)
TSG_M	Toner density sensor control voltage level (M)
TSG_Y	Toner density sensor control voltage level (Y)

LOW	Process speed: Low speed
MIDDLE	Process speed: Medium speed



The toner cartridge must be removed before executing this simulation.

If this simulation is executed with the toner cartridge installed, toner will be forcibly supplied to the developing unit, resulting in over-toner and a trouble.



25-2

<b>Purpose</b>	Setting
<b>Function (Purpose)</b>	Used to make the initial setting of toner density when replacing developer. (Automatic adjustment)
<b>Section</b>	Image process (Photoconductor/Developing/Transfer/Cleaning)

**Operation/Procedure**

- 1) Select a color to be adjusted with the touch panel.
- 2) Press [EXECUTE] key.

The developing motor rotates for 1 min 30 sec, and the toner density sensor makes sampling of the toner density. The detected level is displayed.

After stopping the developing motor, the average value of the toner density sampling results is set as the reference toner density control level.

**Important**

When the above operation is interrupted on the way, the reference toner concentration level is not set. Also when error code of EE-EC, EE-EL or EE-EU is displayed, the reference toner density level is not set normally.

Do not execute this simulation except when new developer is supplied. If it is executed in other cases, undertoner or overtone may occur, causing a trouble.

Division	Item/Display	Display range	Default value
Toner density control adjustment value in the low speed process mode	AT DEVE ADJ_L_K	1 - 255	128
	AT DEVE ADJ_L_C	1 - 255	128
	AT DEVE ADJ_L_M	1 - 255	128
	AT DEVE ADJ_L_Y	1 - 255	128
Toner density control adjustment value in the medium speed process mode	AT DEVE ADJ_M_K	1 - 255	128
	AT DEVE ADJ_M_C	1 - 255	128
	AT DEVE ADJ_M_M	1 - 255	128
	AT DEVE ADJ_M_Y	1 - 255	128
Toner density sensor control voltage level in the low speed process mode	AT DEVE VO_L_K	1 - 255	128
	AT DEVE VO_L_C	1 - 255	128
	AT DEVE VO_L_M	1 - 255	128
	AT DEVE VO_L_Y	1 - 255	128
Toner density sensor control voltage level in the medium speed process mode	AT DEVE VO_M_K	1 - 255	128
	AT DEVE VO_M_C	1 - 255	128
	AT DEVE VO_M_M	1 - 255	128
	AT DEVE VO_M_Y	1 - 255	128

**Display during execution of the simulation**

Item/Display	Content
TCS_K	Toner sensor output value (K)
TCS_C	Toner sensor output value (C)
TCS_M	Toner sensor output value (M)
TCS_Y	Toner sensor output value (Y)
TSG_K	Toner density sensor control voltage level (K)
TSG_C	Toner density sensor control voltage level (C)
TSG_M	Toner density sensor control voltage level (M)
TSG_Y	Toner density sensor control voltage level (Y)

**Error content**

Display	Error name	Error content
EE-EL	EL abnormality	The sensor output level is less than 77, or the control voltage exceeds 207.
EE-EU	EU abnormality	The sensor output level exceeds 177, or the control voltage is less than 52.
EE-EC	EC abnormality	The sensor output level is outside of 128±3.

25-4

<b>Purpose</b>	Adjustment/Setting/Operation data check
<b>Function (Purpose)</b>	Used to display the operation data of the toner supply quantity. (Not used in the market.)
<b>Section</b>	Process

**Operation/Procedure**

The operation data of the toner supply quantity are displayed.

Item/Display	Content	Display range
YLD_CNT_FB	Toner supply FB rate by the yield count	50 - 200
DELTA_DVB	Delta DVB (Process control DVB - Target DVB)	-500 - 500
IDL_DVB	Target DBV	100 - 600
PROCON_DVB	Process control DVB	100 - 600
DV_LIFE	Developer life area	1 - 8
COVERAGE_AREA	Average print rate area	1 - 10
ENV_AREA	Environment area	1 - 8
MULTI_TIME	Toner supply drive time area (Specified by the DV motor rotation time)	1 - 8
PRO_FB_CNT	No. of remaining times of toner supply for the process control result	0 - 65535
PRO_FB_INT	Interval of toner supply for the process control result	0 - 65535
PRO_FB_RATIO	Correction rate of one-time toner supply for the process control result	-10 - 10
RECV_MODE_CNT(+)	No. of times of recovery mode (+) (No. of times of compulsory toner supply)	0 - 65535
RECV_MODE_CNT(-)	No. of times of recovery mode (-) (No. of times of compulsory printing of one-color background image)	0 - 65535

25-5

<b>Purpose</b>	Adjustment/Setting/Operation data check
<b>Function (Purpose)</b>	Used to display the toner density correction data. (Not used in the market.)
<b>Section</b>	Process

**Operation/Procedure**

The toner density correction data are displayed.

Item/Display	Content	Display range
TCS OUTPUT	Toner sensor output value	0 - 255
DELTA_TSG	Toner density sensor control voltage level correction value	-255 - 255
TSG_REF	Toner density sensor control voltage level reference value	0 - 255
TN_FALL_CNT_JOB	Toner fall amount during a job (latest average value)	0 - 255
TN_FALL_JUDGE_CNT	Toner fall judgment threshold value during a job	0 - 255
TN_FALL_MODE_CNT	No. of times of job interruption toner supply operation mode	0 - 255
TN_FALL_CNT_INT	Latest average value of toner fall amount in job interruption toner supply operation	0 - 255
TN_FALL_CNT_NEW	Latest average value of toner fall amount when installing a new toner cartridge	0 - 255
TCS_ERR_MODE_CNT(+)	No. of times of TCS abnormality detection mode (+) (Undertoner)	0 - 65535
TCS_ERR_MODE_CNT(-)	No. of times of TCS abnormality detection mode (-) (Overtone)	0 - 65535

# 26

## 26-1

<b>Purpose</b>	Setting
<b>Function (Purpose)</b>	Used to set Yes/No of installation of the right paper exit tray.
<b>Section</b>	Paper exit

### Operation/Procedure

- 1) Enter the set value with 10-key.
  - 2) Press [OK] key. (The set value is saved.)
- This setting is required to use the right paper exit tray unit.

Item/Display		Content
A	0 YES	Paper exit tray: YES
	1 NO	Paper exit tray: NO

## 26-2

<b>Purpose</b>	Setting
<b>Function (Purpose)</b>	Used to set the paper size of the large capacity tray (LCC). (When the paper size is changed, this simulation must be executed to change the paper size in software.)
<b>Section</b>	Paper feed

### Operation/Procedure

Select a paper size and a weight system to be changed.

Item	Setting value	Content
LCC	0	8.5 x 11
	1	A4
	2	B5
G/LBS SET	0	GRAM
	1	LBS

Destination	Setting value	
	LCC	G/LBS SET
U.S.A	8.5 x 11	LBS
CANADA	8.5 x 11	LBS
INCH	8.5 x 11	LBS
JAPAN	A4	GRAM
AB_B	A4	GRAM
EUROPE	A4	GRAM
U.K.	A4	GRAM
AUS.	A4	GRAM
AB_A	A4	GRAM
CHINA	A4	GRAM

## 26-3

<b>Purpose</b>	Setting
<b>Function (Purpose)</b>	Used to set the specifications of the auditor. (Setting must be made according to the auditor use conditions.)
<b>Section</b>	Auditor

### Operation/Procedure

Select an item to be set with the touch panel.

Item/Display	Content	Default value	
BUILT-IN AUDITOR	P10 Built-in auditor mode (standard mode) operation.	P10	
OUTSIDE AUDITOR	NONE	No external connection vendor is used.	NONE
	P VENDOR1	Coin vendor mode (Only the copy mode can be controlled.)	
	P VENDOR3	Vendor mode in which signals for the intercard connected to the PCU are used for communication in parallel I/F.	
	P OTHER	Mode for an external auditor connected to the SCU.	
	VENDOR-EX (*1)	Vendor I/F for EQUITRAC	
	VENDOR-EX (MULTI) (*1)	VENDOR-EX + Multi job cueing Enable mode	
	S_VENDOR	Serial vendor mode	
DOC ADJ	ON	Support for the auditor in document filing print	OFF
	OFF	No support for the auditor in document filing print	
PF ADJ	ON	Continuous printing is performed in the duplex print mode. If the remaining money expires during continuous printing, the sheets in the machine are discharged without being printed on the back surfaces.	OFF
	OFF	Continuous printing is not performed in the duplex print mode. (The remaining amount is checked for printing every surface in all the printing process.) If the remaining money expires during printing, the sheet is discharged without printing on the back surface.	
VENDOR MODE (*2)	MODE1	Vendor mode 1	MODE 3
	MODE2	Vendor mode 2	
	MODE3	Vendor mode 3	
COUNTUP TIMING	FUSER_IN	Mode in which the detection timing of the paper lead edge by the sensor after the paper passes the fusing section is used as the money charging timing.	EXIT_OUT
	FUSER_OUT	Mode in which the detection timing of the paper rear edge by the sensor after the paper passes the fusing section is used as the money charging timing.	
	EXIT_OUT	Mode in which the detection timing of the paper rear edge by the paper exit sensor of the right paper exit tray or of the after process unit is used as the money charging timing.	

(\*1) Displayed only when EQUITRAC.

(\*2) Details of the vendor mode

## Details of the vendor mode

	Completion of the specified quantity. (Money remaining)	Insufficient money during copy job		Completion of the specified quantity. (No money remaining)
		BW/Color (no money remaining)	Color (Money remaining)	
	Condition 1	Condition 2	Condition 3	Condition 4
MODE1	Operation 1	Operation 2	Operation 2	Operation 1
MODE2	Operation 1	Operation 1	Operation 2	Operation 1
MODE3	Operation 1	Operation 3	Operation 2	Operation 3

Operation 1:

Standby during setting time of auto clear. Default is 60 seconds, which can be changed in the system setting.

Operation 2:

Auto clear is not made.

Operation 3:

The display is shifted to the initial screen.

### 26-5

<b>Purpose</b>	Setting
<b>Function (Purpose)</b>	Used to set the count mode of the total counter and the maintenance counter. (A3/11x17 size)

### Section

#### Operation/Procedure

- 1) Select an item to be set with scroll keys.
- 2) Enter the setting value with 10-key  
1 = Count up by 1, 2 = Count up by 2
- 3) Press [OK] key.  
The set value in step 2) is saved.

Item/Display	Content	Default value
A TOTAL (B/W)	Total counter (B/W)	1 (Japan) 2 (Except Japan)
B TOTAL (COL)	Total counter (Color)	
C MAINT (B/W)	Maintenance counter (B/W)	2
D MAINT (COL)	Maintenance counter (Color)	
E DEV (B/W)	Developer counter (B/W)	
F DEV (COL)	Developer counter (Color)	

### 26-6

<b>Purpose</b>	Setting
<b>Function (Purpose)</b>	Used to set the specifications (paper, fixed magnification ratio, etc.) of the destination.

### Section

#### Operation/Procedure

- 1) Select an item to be set with the touch panel.
- 2) Press [EXECUTE] key.  
The selected set content is saved.

U.S.A.	United States of America
CANADA	Canada
INCH	Inch series, other destinations
JAPAN	Japan
AB_B	AB series (B5 detection), other destinations
EUROPE	Europe
U.K.	United Kingdom
AUS.	Australia
AB_A	AB series (A5 detection), other destinations
CHINA	China

### 26-7

<b>Purpose</b>	Setting
<b>Function (Purpose)</b>	Used to set the machine ID. (26cpm/36cpm/31cpm(A) machine)

### Section

#### Operation/Procedure

- 1) Enter the machine ID with the 10-key.  
Max. 30 digits of numerals and alphabetical characters can be inputted.  
To select a desired character, press the 10-key repeatedly.  
Refer to the following list and enter characters.  
Touch the "CONFIRM" section every time a character is inputted.  
To modify an inputted character, delete it with "CLEAR" key and enter the correct character.
- 2) Press [SET] key to set the contents entered in procedure 1).

### Note

The machine ID can be set also by the Web Page service mode function.

Conventionally, the machine ID has been set by the Web Page function. In this mode, this function is made available in the simulation mode.

10-key	Number of times of key input									
	1	2	3	4	5	6	7	8	9	10
1	1	-	-	-	-	-	-	-	-	-
2	A	B	C	a	b	c	2	-	-	-
3	D	E	F	d	e	f	3	-	-	-
4	G	H	I	g	h	i	4	-	-	-
5	J	K	L	j	k	l	5	-	-	-
6	M	N	O	m	n	o	6	-	-	-
7	P	Q	R	S	p	q	r	s	7	-
8	T	U	V	t	u	v	8	-	-	-
9	W	X	Y	Z	w	x	y	z	9	-
0	0	-	-	-	-	-	-	-	-	-

### 26-10

<b>Purpose</b>	Setting
<b>Function (Purpose)</b>	Used to set the trial mode of the network scanner.

### Section

#### Operation/Procedure

- 1) Enter the set value with 10-key.
- 2) Press [OK] key.  
The set value in step 1) is saved.

TRIAL MODE (0: YES 1: NO)	0	Trial mode setting
	1	Trial mode cancel (Default)

26-18

<b>Purpose</b>	Setting
<b>Function (Purpose)</b>	Used to set Disable/Enable of the toner save mode operation. (For the Japan and the UK versions.)

**Section****Operation/Procedure**

- 1) Select an item to be set with scroll keys.
- 2) Enter the set value with 10-key.
- 3) Press [OK] key.

The set value in step 2) is saved.

**18cpm/20cpm/23cpm/31cpm(G) machine**

Item	Display	Content	Default value
A	COPY	0 Copy toner save mode is inhibited.	0
		1 Copy toner save mode is allowed	
B	PRINTER	0 Printer toner save mode is inhibited.	0
		1 Printer toner save mode is allowed.	

**26cpm/36cpm/31cpm(A) machine**

Item	Display	Content	Setting range	Default value	NOTE
A	COPY (0: OFF 1: SV1 2: SV2 3: SV3)	0 Copy toner save mode NOT available	0 - 3	0	1: Toner save LOW  3: Toner save HIGH
		1 Copy toner save mode 1			
		2 Copy toner save mode 2			
		3 Copy toner save mode 3			
B	PRINTER (0: OFF 1: SV1 2: SV2 3: SV3)	0 Printer toner save mode NOT available	0 - 3	0	1: Toner save LOW  3: Toner save HIGH
		1 Printer toner save mode 1			
		2 Printer toner save mode 2			
		3 Printer toner save mode 3			
C	COPY TS DISPLAY (0: YES 1: NO)	0 Setting of copy toner save is displayed.	0 - 1	1 (Linked with the set value of SIM26-6.)	
		1 Setting of copy toner save is not displayed.			
D	PRINTER TS DISPLAY (0: YES 1: NO)	0 Setting of printer toner save is displayed.	0 - 1	1 (Linked with the set value of SIM26-6.)	
		1 Setting of printer toner save is not displayed.			

Destination	Default value C	Default value D
U.S.A	0 (Displayed)	0 (Displayed)
CANADA	0 (Displayed)	0 (Displayed)
INCH	0 (Displayed)	0 (Displayed)
JAPAN	1 (Not Displayed)	0 (Displayed)
AB_B	0 (Displayed)	0 (Displayed)
EUROPE	0 (Displayed)	0 (Displayed)
U.K.	1 (Not Displayed)	0 (Displayed)
AUS.	0 (Displayed)	0 (Displayed)
AB_A	0 (Displayed)	0 (Displayed)
CHINA	0 (Displayed)	0 (Displayed)

26-30

<b>Purpose</b>	Setting
<b>Function (Purpose)</b>	Used to set the operation mode corresponding to the CE mark (Europe safety standards). (For slow start to drive the fusing heater lamp)

**Section****Operation/Procedure**

- 1) Enter the set value with 10-key.

0	Control allowed
1	Control inhibited

- 2) Press [OK] key.

The set value in step 1) is saved.

\* Even in Enable state, the control may not be executed due to the power frequency, etc.

U.S.A	1 (CE not supported)	EUROPE	0 (CE supported)
CANADA	1 (CE not supported)	U.K.	0 (CE supported)
INCH	1 (CE not supported)	AUS.	0 (CE supported)
JAPAN	1 (CE not supported)	AB_A	0 (CE supported)
AB_B	1 (CE not supported)	CHINA	0 (CE supported)

26-32

<b>Purpose</b>	Setting
<b>Function (Purpose)</b>	Used to set the specifications of the fusing cleaning operation.

**Section**

Fusing

**Operation/Procedure**

- 1) Enter the set value with 10-key.  
Enable/Disable of the user fusing cleaning function is set.
- 2) Press [OK] key.

Item/Display	Content	Setting range	Default value
A	CLEANING PRINT SET	User fusing cleaning function is Enable.	0 YES
	User fusing cleaning function is Disable.	1 NO	1(NO)

26-35

<b>Purpose</b>	Setting
<b>Function (Purpose)</b>	Used to set the display mode of SIM 22-4 trouble history when a same trouble occurred repeatedly. There are two display modes: display as one trouble and display as several series of troubles.

**Section****Operation/Procedure**

- 1) Enter the set value with 10-key.

0	Only once display.
1	Any time display.

- 2) Press [OK] key.

The set value in step 1) is saved.

26-38

<b>Purpose</b>	Setting
<b>Function (Purpose)</b>	Used to set Continue/Stop of print when the maintenance life is reached.

**Section****Operation/Procedure**

- 1) Enter the set value with 10-key.
- 2) Press [OK] key.

The set value in step 1) is saved.

**18cpm/20cpm/23cpm/26cpm/31cpm machine**

Item/Display	Content	Default value
A MAINTENANCE LIFE OVER (0: CONTINUE 1: STOP)	0 Setting of Print Continue/ Stop when the maintenance life is over (Print Continue)	0
	1 Setting of Print Continue/ Stop when the maintenance life is over (Print Stop)	

**36cpm machine**

Item/Display	Content	Default value
A MAINTENANCE LIFE OVER (0: CONTINUE 1: STOP)	0 Setting of Print Continue/ Stop when the maintenance life is over (Print Continue)	0
	1 Setting of Print Continue/ Stop when the maintenance life is over (Print Stop)	
B FUSER WEB END (0: CONTINUE 1: STOP)	0 Continue/Stop setting of print when the fusing web is end (Print Continue)	1
	1 Continue/Stop setting of print when the fusing web is end (Print Stop)	

26-41

<b>Purpose</b>	Setting
<b>Function (Purpose)</b>	Used to set Enable/Disable of the magnification ratio automatic select function (AMS) in the center binding mode.

**Section****Operation/Procedure**

- 1) Enter the set value with 10-key.

0	AMS Disable
1	AMS Enable

- 2) Press [OK] key.

The set value in step 1) is saved.

**<Default value of each destination>**

U.S.A	0 (Disable)	EUROPE	1 (Enable)
CANADA	0 (Disable)	U.K.	1 (Enable)
INCH	0 (Disable)	AUS.	0 (Disable)
JAPAN	0 (Disable)	AB_A	0 (Disable)
AB_B	0 (Disable)	CHINA	0 (Disable)

26-49

<b>Purpose</b>	Setting
<b>Function (Purpose)</b>	Used to set the print speed of postcards mode.

**Section****Operation/Procedure**

Select the copy speed mode with the touch panel. (Default: LOW)

Item/Setting value	Content	Default value
LOW	Postcard copy speed LOW	LOW
HIGH	Postcard copy speed HIGH	

26-50

<b>Purpose</b>	Setting
<b>Function (Purpose)</b>	Used to set functions.

**Section****Operation/Procedure**

- 1) Select a target item of setting with scroll key on the touch panel.
- 2) Enter the set value with 10-key.
- 3) Press [OK] key. (The set value is saved.)

Item/Display	Content	Default value
A BW REVERSE	0 BW reverse copy Disable	Refer to *1
	1 BW reverse copy Enable	
B COLOR MODE	2-color/Single color copy mode Enable/Disable setting	Refer to *1/*2
C FINISHER FUNCTION	0 Finisher special paper The number of paper exit is limited.	0 Refer to *3
	1 Finisher special paper The number of paper exit is not limited.	
D COLOR MODE (PRINTER)	0 All colors and monochrome counters are displayed.	Refer to *1
	1 All are displayed except for the 3-color print counter.	
	2 Monochrome and full color print counters are displayed.	
E FEED TRAY COLOR	0 Paper feed tray color display ON during paper feed	0
	1 Paper feed tray color display OFF during paper feed	
F LONG SIZE PRINT	0 Long size print enable	0
	1 Long size print disable	

(\*1) Default values for each destination of item A/B/D

Destination	Item A	Item B	Item D
U S A	1	0	2
CANADA	1	0	2
INCH	1	0	2
JAPAN	1	7	2
AB_B	1	0	2
EUROPE	1	0	2
U K	0	0	2
AUS	1	0	2
AB_A	1	0	2
CHINA	1	0	2

(\*2) Item B: COLOR MODE set value (OFF: Displayed/ON: Not displayed)

Set value	Mode		2-Color/Single Counter
	Single	2-color	
0	OFF	OFF	OFF
1	OFF	ON	OFF
2	ON	OFF	OFF
3	ON	ON	OFF
4	OFF	OFF	ON
5	OFF	ON	ON
6	ON	OFF	ON
7	ON	ON	ON

(\*3)

	Target paper	Target paper setting	
		0	1
Inner finisher	Postcard, envelope	The operation is stopped when 10 sheets of a same kind are discharged continuously. When, however, different kinds of sheets are mixed and discharged and 10 or less sheets of a kind are continuously discharged, the operation is stopped by the paper exit tray full detection.	If it is set to "1," the operation is stopped when the paper exit tray is full or when 250 sheets (35.5mm thick) are discharged.
	Label sheet, tab sheet, OHP	The operation is stopped when 100 sheets of a same kind are discharged continuously. When, however, different kinds of sheets are mixed and discharged and 100 or less sheets of a kind are continuously discharged, the operation is stopped by the paper exit tray full detection.	
Saddle stitch finisher	Postcard, envelope	The operation is stopped when 30 sheets of a same kind are discharged continuously. When, however, different kinds of sheets are mixed and discharged and 30 or less sheets of a kind are continuously discharged, the operation is stopped by the paper exit tray full detection.	If it is set to "1," the operation is stopped when the paper exit tray is full or when 500 sheets (67mm thick) are discharged.
	Label sheet, tab sheet, OHP	The operation is stopped when 100 sheets of a same kind are discharged continuously. When, however, different kinds of sheets are mixed and discharged and 100 or less sheets of a kind are continuously discharged, the operation is stopped by the paper exit tray full detection.	

26-51

<b>Purpose</b>	Setting
<b>Function (Purpose)</b>	Used to set the specifications of the serial port operation. (For PCI)

**Section**

**Operation/Procedure**

- 1) Enter the set value with 10-key.  
When the PCI is installed, setting is made to 1 or 2.
- 2) Press [OK] key.

Item/Display	Content	Setting range	Default value
A	PCI SETTING	Serial port PCI mode OFF (→For connecting the serial port vendor) Serial port PCI mode ON (JOB status LED: MODE1) Serial port PCI mode ON (JOB status LED: MODE2)	0 0 (Serial port PCI mode OFF)

MODE1: Red LED is light/blink/OFF, MODE2: Red LED always OFF



When "PCI SETTING" is changed from "0" to "1" or "2," if SIM26-03 "OUTSIDE AUDITOR" is set to "S\_VENDOR," "OUTSIDE AUDITOR" is changed to "NONE."

26-52

<b>Purpose</b>	Setting
<b>Function (Purpose)</b>	Used to set whether non-printed paper (insertion paper, cover paper) is counted up or not.

**Section**

**Operation/Procedure**

- 1) Enter the set value with 10-key.

0	Count up
1	No count up

- 2) Press [OK] key.

The set value in step 1) is saved.

Destination	Default
U.S.A	0 (Counted)
CANADA	0 (Counted)
INCH	0 (Counted)
JAPAN	1 (Not counted)
AB_B	0 (Counted)
EUROPE	0 (Counted)
U.K.	0 (Counted)
AUS.	1 (Not counted)
AB_A	0 (Counted)
CHINA	0 (Counted)

**26-53** Setting

**Purpose** Setting

**Function (Purpose)** User auto color calibration (color balance adjustment) Inhibit/Allow setting.

**Section**

**Operation/Procedure**

- 1) Enter the set value with 10-key.

Item/Display	Content	Setting range	Default value
A COPY (1:YES 0:NO)	Copy mode	Allow	1
		Inhibit	0
B PRINTER (1:YES 0:NO)	Printer mode	Allow	1
		Inhibit	0

- 2) Press [OK] key.  
The set value in step 1) is saved.

**26-65** Setting

**Purpose** Setting

**Function (Purpose)** Used to set the finisher alarm mode.

**Section**

**Operation/Procedure**

Use the touch key to set.

Item	Set value	Content	Setting range	Default value	NOTE
LIMIT SHEETS	30	Number of sheets of stapling: Max. 30	30 or 50	50	A4, A4R, B5, 8.5" x 11", 8.5" x 11"R, 16K, 16KR For saddle stitch finisher
	50	Number of sheets of stapling: Max. 50			
LIMIT COPIES	ON	Number of sets of stapling: Max. 50 sets	ON or OFF	ON	
	OFF	Number of sets of stapling: Not Limited			
LIMIT SHEETS (L)	25	Number of sheets of stapling: Max. 25	25 or 30	25	A3, B4, 11" x 17", 8.5" x 14", 8.5" x 13.5", 8.5" x 13.4", 8.5" x 13", 8K For saddle stitch finisher
	30	Number of sheets of stapling: Max. 30			
SADDLE COPIES	ON	Number of sets loaded in the saddle staple: Limited	ON or OFF	ON	For saddle stitch finisher
	OFF	Number of sets loaded in the saddle staple: Not Limited			

**26-69** Setting

**Purpose** Setting

**Function (Purpose)** Used to set the operating conditions for toner near end.

**Section**

**Operation/Procedure**

- 1) Select an item to be set with scroll keys.
- 2) Enter the set value with 10-key.
- 3) Press [OK] key.

The set value in step 2 is saved.

Item/Display	Content	Setting range	Default value
A TONER PREPARATION (0:YES 1:NO)	0 The toner preparation message is displayed.	0 - 1	List of Default values and set values for each destination
	1 The toner preparation message is not displayed.		
B REMAINING TONER LEVEL	0.05 0 Toner preparation at remaining toner level of 5%	0 - 9	
	0.1 1 Toner preparation at remaining toner level of 10%		
	0.15 2 Toner preparation at remaining toner level of 15%		
	0.2 3 Toner preparation at remaining toner level of 20%		
	0.25 4 Toner preparation at remaining toner level of 25%		
	0.3 5 Toner preparation at remaining toner level of 30%		
	0.35 6 Toner preparation at remaining toner level of 35%		
	0.4 7 Toner preparation at remaining toner level of 40%		
	0.45 8 Toner preparation at remaining toner level of 45%		
C TONER NEAR END (0:YES 1:NO)	0 The toner near end message is displayed.	0 - 1	
	1 The toner near end message is not displayed.		
D TONER END	1 Operation setup 1	1 - 3	
	2 Operation setup 2		
	3 Operation setup 3		

Item/Display	Content	Setting range	Default value
E	TONER END COUNT Setting of the number of copy/print/FAX outputs Enable after TONER NEAR END.	1 - 3	1
F	TONER E-MAIL ALERT 0 Low status send of E-mail alert (When the toner preparation message is displayed) (in near near toner end) 1 Low status send of E-mail alert (near toner end)	0 - 1	1

**Item E (TONER END COUNT) setting value and printable quantity**

Setting value	Printable quantity at A4/5% equivalent conversion
1	0
2	25
3	50

**<List of Default values and set values for each destination>**

Destination	Setting value			Enable/Disable of print job continuation at toner end
	Toner preparation message	Toner preparation time	Toner near end message	
U.S.A	0 (Displayed)	4 (Displayed when the toner remaining quantity is 25%.)	0 (Displayed)	2 (Print operation stopped)
CANADA	0 (Displayed)	4 (Displayed when the toner remaining quantity is 25%.)	0 (Displayed)	
INCH	0 (Displayed)	4 (Displayed when the toner remaining quantity is 25%.)	0 (Displayed)	
JAPAN	0 (Displayed)	4 (Displayed when the toner remaining quantity is 25%.)	1 (Not Displayed)	
AB_B	0 (Displayed)	4 (Displayed when the toner remaining quantity is 25%.)	0 (Displayed)	

Destination	Setting value			Enable/Disable of print job continuation at toner end
	Toner preparation message	Toner preparation time	Toner near end message	
EUROPE	0 (Displayed)	4 (Displayed when the toner remaining quantity is 25%.)	0 (Displayed)	2 (Print operation stopped)
U.K.	0 (Displayed)	4 (Displayed when the toner remaining quantity is 25%.)	0 (Displayed)	
AUS.	0 (Displayed)	4 (Displayed when the toner remaining quantity is 25%.)	0 (Displayed)	
AB_A	0 (Displayed)	4 (Displayed when the toner remaining quantity is 25%.)	0 (Displayed)	
CHINA	0 (Displayed)	4 (Displayed when the toner remaining quantity is 25%.)	0 (Displayed)	1 (Print operation continued)

(Contents of set items)

- A: Enable/Disable setting of the toner preparation message display.
- B: The toner remaining quantity at which the toner preparation message is displayed.
- C: Enable/Disable setting of the toner preparation message display when the toner near end status is reached.
- D: Machine operation at toner end
- E: Number of allowable copy/print/FAX when the toner near end message is displayed. (Range: 0 - 50 sheets)

The number of output print allowed in item D is based on the assumption that the sheets are of A4 size with print ratio of 5%. (The number of outputs allowed differs depending on the paper size and the print ratio.)

**Important**

When item A is set to "0" and item E is properly set, printing can be made after toner near end. However, improper phenomena such as insufficient density, thin spots, or improper color balance may result depending on the using conditions. When item E is set to "1" printing is disabled after toner near end. In this case, toner end display is made in the toner near end status, and copy/print/FAX outputs are disabled.



**26-71**

**Purpose** Setting

**Function (Purpose)** Used to set the trial mode of the web browsing function. (26cpm/36cpm/31cpm(A) machine)

**Section**

**Operation/Procedure**

- 1) Enter the set value with 10-key.
- 2) Press [OK] key.

Item/Display	Content	Setting range	Default value
A	WEB BROWSING TRIAL MODE (0: YES 1: NO)	0	Web browsing trial mode setting
		1	Web browsing trial mode canceling
		0 - 1	1

**26-73**

**Purpose** Setting

**Function (Purpose)** Enlargement continuous shoot, A3 wide copy mode image loss (shade delete quantity) adjustment

**Section**

**Operation/Procedure**

- 1) Select an item to be set with scroll keys.
  - 2) Enter the set value with 10-key.
  - 3) Press [OK] key.
- When the adjustment value is increased, the image loss (shade delete quantity) is increased.

Item/Display	Content	Setting range	Default value
A	DELETING SHADOW ADJ (M)	Rear frame side image loss quantity (shade delete quantity) adjustment	0 - 50 0 (Adjustment amount: 0.1mm/step)
B	DELETING SHADOW ADJ (S)	Lead edge image loss quantity (shade delete quantity) adjustment	0 - 50 0 (Adjustment amount: 0.1mm/step)

**26-74**

**Purpose** Setting

**Function (Purpose)** Used to set the OSA trial mode.

**Section**

**Operation/Procedure**

- 1) Enter the set value with 10-key.
- 2) Press [OK] key.

Item/Display	Content	Setting range	Default value
A	OSA TRIAL MODE (0: YES 1: NO)	0	Used to set the OSA trial mode.
		1	OSA trial mode is canceled.
		0 - 1	1

**26-78**

**Purpose** Setting

**Function (Purpose)** Used to set the password of the remote operation panel.

**Section**

**Operation/Procedure**

- 1) Enter a password with 10-key. (5 - 8 digits)  
The entered password is displayed on the column of "NEW".  
In order to correct the entered password, press the [clear] key to delete the entered value one digit by one digit.
- 2) Press [SET] key.

**26-79**

**Purpose** Setting

**Function (Purpose)** Used to set YES/NO of the pop-up display of user data delete result.

**Section**

**Operation/Procedure**

- 1) Enter the set value with 10-key.  
The value for the display operation specification after completion of user data delete is set.
- 2) Press [OK] key.

Item/Display	Content	Setting range	Default value
A	DISP SET	User data delete result pop-up display ON	YES 1
		User data delete result pop-up display OFF	NO 0
			0 (NO)

**27**

**27-1**

**Purpose** Setting

**Function (Purpose)** Used to set non-detection of communication error (U7-00) with RIC. (FSS function)

**Section**

**Operation/Procedure**

- 1) Enter the set value with 10-key.

0	Not detection
1	Detection

- 2) Press [OK] key.  
The set value in step 1) is saved.

**27-2**

<b>Purpose</b>	Setting
<b>Function (Purpose)</b>	Used to set the sender's registration number and the HOST server telephone number. (FSS function)

**Section**

**Operation/Procedure**

- 1) Select an item to be set with touch panel.  
[USER FAX NO] [SERVA TEL NO]
- 2) Enter the set value with 10-key.
- 3) Press [SET] key.  
The set value in step 2) is saved.

USER FAX_NO.	Sender registration number (Max. 16 digits)
SERVA TEL_NO.	Host server telephone number (Max. 16 digits) <ul style="list-style-type: none"> <li>• If the connection process is not completed normally when registering the FSS, calling to the HOST may be continuously made every time when the power is turned ON (from OFF) or rebooted.</li> </ul> In this case, enter "*****" to inhibit calling to the HOST.

**27-4**

<b>Purpose</b>	Setting
<b>Function (Purpose)</b>	Used to set the initial call and toner order auto send. (FSS function)

**Section**

**Operation/Procedure**

- 1) Select an item to be set with scroll keys.
- 2) Enter the set value with 10-key.
- 3) Press [OK] key.  
The set value in step 2) is saved.

Item/Display		Content		Setting range	Default value	Remarks	
A	FSS MODE	NEB1	Set the FSS MODE	0 - 3	0	1	
		NEB2	Exclusive for send in NE-B mode		1		
		NFB1	Send/Receive in NE-B mode		2		For convenience stores
		NFB2	Exclusive for send in NE-F mode		3		For convenience stores
B	RETRY_BUSY	Resend number setting when busy		0 - 15	2	0: No retry	
C	TIMER(MINUTE)_BUSY	Resend timer setting (minute) when busy		1 - 15	3		
D	RETRY_ERROR	Resend number setting when error		0 - 15	1	0: No retry	
E	TIMER(MINUTE)_ERROR	Resend timer setting (minute) when error		1 - 15	1		
F	FAX_RETRY	Resend number setting when FAX initial connection		0 - 15	2	Unit: Number of times	
G	TONER ORDER TIMING(K)	EMPTY	Toner order auto send timing setting (K)	0 - 11	0	6	
		NEAR_END	Empty		1		
		0.05	Near end		2		
		0.1	0.05		3		
		0.15	0.1		4		
		0.2	0.15		5		
		0.25	0.2		6		
		0.3	0.25		7		
		0.35	0.3		8		
		0.4	0.35		9		
		0.45	0.4		10		
		0.5	0.45		11		

Item/Display			Content		Setting range		Default value	Remarks
H	TONER ORDER TIMING(C)	EMPTY	Toner order auto send timing setting (C)	Empty	0 - 11	0	6	
		NEAR_END		Near end		1		
		0.05		0.05		2		
		0.1		0.1		3		
		0.15		0.15		4		
		0.2		0.2		5		
		0.25		0.25		6		
		0.3		0.3		7		
		0.35		0.35		8		
		0.4		0.4		9		
		0.45		0.45		10		
		0.5		0.5		11		
I	TONER ORDER TIMING(M)	EMPTY	Toner order auto send timing setting (M)	Empty	0 - 11	0	6	
		NEAR_END		Near end		1		
		0.05		0.05		2		
		0.1		0.1		3		
		0.15		0.15		4		
		0.2		0.2		5		
		0.25		0.25		6		
		0.3		0.3		7		
		0.35		0.35		8		
		0.4		0.4		9		
		0.45		0.45		10		
		0.5		0.5		11		
J	TONER ORDER TIMING(Y)	EMPTY	Toner order auto send timing setting (Y)	Empty	0 - 11	0	6	
		NEAR_END		Near end		1		
		0.05		0.05		2		
		0.1		0.1		3		
		0.15		0.15		4		
		0.2		0.2		5		
		0.25		0.25		6		
		0.3		0.3		7		
		0.35		0.35		8		
		0.4		0.4		9		
		0.45		0.45		10		
		0.5		0.5		11		
K	TEMP HISTORY CYCLE	Frequency of acquiring the temperature and humidity history		1 - 1440		60	Unit: min.	
L	LOG OUTPUT CAPACITY(PCU)	Log output capacity		0 - 50		30	Unit: [KB]	

27-5

<b>Purpose</b>	Setting
<b>Function (Purpose)</b>	Used to set the machine tag No. (This function allows the host computer to check the machine tag No.) (FSS function)
<b>Section</b>	Communication (RIC/MODEM)

**Operation/Procedure**

- Enter the password (max. 8 digits) with 10-key.  
The entered password is displayed on the column of "NEW".  
In order to correct the entered password, press the [clear] key to delete the entered value one digit by one digit.
- Press [SET] key.

27-6

<b>Purpose</b>	Setting
<b>Function (Purpose)</b>	Used to set of the manual service call. (FSS function)
<b>Section</b>	

**Operation/Procedure**

- Enter the set value with 10-key.

0	Allow (Default)
1	Inhibit

- Press [OK] key.  
The set value in step 1) is saved.

27-7

<b>Purpose</b>	Setting
<b>Function (Purpose)</b>	Used to set of the enable, alert callout. (FSS function)
<b>Section</b>	

**Operation/Procedure**

- Select an item to be set with scroll keys.
- Enter the set value with 10-key.
- Press [OK] key.  
The set value in step 2) is saved.

Item/Display	Content	Setting range	Default value
A	FUNCTION (0: YES 1: NO)	FSS function enable 0	1 (NO)
		FSS function disable 1	
B	ALERT (0: YES 1: NO)	Alert call enable (*1) 0	0 (YES)
		Alert call disable 1	
C	CONNECTION (0: FAX 1: No Use 2: HTTP)	FAX connection enable 0	0 (FAX)
		Not used. 1	
		HTTP connection enable 2	

\*1 Alert send timing

No alert cause	Initial state / Trouble / Continuous JAM alert
Maintenance	When the maintenance timing is reached.
Service call	When pressing Service call.
Toner send request	When the toner order automatic send setting is reached.
Toner collection request	Revision of the toner installation date (only for a new product)
Alert resend	

27-9

<b>Purpose</b>	Setting
<b>Function (Purpose)</b>	Used to set the paper transport time recording YES/NO threshold value and shading gain adjustment retry number. (FSS function)
<b>Section</b>	

**Operation/Procedure**

- Select an item to be set with scroll keys.
- Enter the set value with 10-key.
- Press [OK] key.  
The set value in step 2) is saved.

Item/Display	Content	Setting range	Default value
A	FEED TIME1	Threshold value of paper transport time between sensors (Machine)	0 - 100 50(%)
B	FEED TIME2	Threshold value of paper transport time between sensors (SPF)	0 - 100 50(%)
C	GAIN ADJUSTMENT RETRY	Threshold value of the gain adjustment retry number	0 - 20 11 (TIMES)
D	JAM ALERT	Continuous JAM alert judgment threshold value (Alert judgment threshold value for continuous JAM's) (Setting of the number of JAM's continuously made at which it is judged as an alert.)	1 - 100 10 (TIMES)

\* Items A, B: 0%, standard passing time between sheets of paper; 100%, time for judgment as a jam between sheets of paper.

\* Item C: Because of a trouble in shading operation, the number of retry is actually not registered.

27-10

<b>Purpose</b>	Data clear
<b>Function (Purpose)</b>	Used to clear the trouble prediction history information. (FSS function)
<b>Section</b>	

**Operation/Procedure**

- Press [EXECUTE] key.
- Press [YES] key.  
The history information of trouble prediction is cleared.

Target history	Serial communication retry history
	High density process control error history
	Halfone process control error history
	Automatic registration adjustment error history
	Scanner gain adjustment retry history
	Paper transport time between sensors

27-11

<b>Purpose</b>	Others
<b>Function (Purpose)</b>	Used to check the serial communication retry number and the scanner gain adjustment retry number history. (FSS function)

<b>Section</b>
----------------

**Operation/Procedure**

The serial communication retry number history and the scanner gain adjustment retry number history are displayed.

Display Item			Content
Item name	Occurrence date (Display)	Retry number	
LSU1	Year/month/day hour: min.: sec.	8 digits	Serial communication retry number history display
LSU2	Year/month/day hour: min.: sec.	8 digits	
DESK1	Year/month/day hour: min.: sec.	8 digits	
DESK2	Year/month/day hour: min.: sec.	8 digits	
FINISHER1	Year/month/day hour: min.: sec.	8 digits	
FINISHER2	Year/month/day hour: min.: sec.	8 digits	
SCAN GAIN ADJ1	Year/month/day hour: min.: sec.	8 digits	Scanner gain adjustment retry history
SCAN GAIN ADJ2	Year/month/day hour: min.: sec.	8 digits	
SCAN GAIN ADJ3	Year/month/day hour: min.: sec.	8 digits	
SCAN GAIN ADJ4	Year/month/day hour: min.: sec.	8 digits	
SCAN GAIN ADJ5	Year/month/day hour: min.: sec.	8 digits	Scanner gain adjustment retry history

27-12

<b>Purpose</b>	Others
<b>Function (Purpose)</b>	Used to check the high density, halftone process control and the automatic registration adjustment error history. (FSS Function)

<b>Section</b>
----------------

**Operation/Procedure**

The high density, halftone process control and the automatic registration adjustment error history is displayed.

HV_ERR1	High density process control error history 1
HV_ERR2	High density process control error history 2
HV_ERR3	High density process control error history 3
HV_ERR4	High density process control error history 4
HV_ERR5	High density process control error history 5
H_TONE ERR1	Halftone process control error history 1
H_TONE ERR2	Halftone process control error history 2
H_TONE ERR3	Halftone process control error history 3
H_TONE ERR4	Halftone process control error history 4
H_TONE ERR5	Halftone process control error history 5
AUTO REG ADJ1	Automatic registration adjustment error history 1
AUTO REG ADJ2	Automatic registration adjustment error history 2
AUTO REG ADJ3	Automatic registration adjustment error history 3
AUTO REG ADJ4	Automatic registration adjustment error history 4
AUTO REG ADJ5	Automatic registration adjustment error history 5

27-13

<b>Purpose</b>	Others
<b>Function (Purpose)</b>	Used to check the history of paper transport time between sensors. (FSS function)

<b>Section</b>
----------------

**Operation/Procedure**

Change the display with scroll key.

	Item/Display	Content	Occurrence date	Code between sensors	Passing time	Reference passing time
Main unit	FEED TIME1	History of paper transport time between sensors 1	Year/month/day hour: min.: sec.	5 digits	5 digits (ms)	5 digits (ms)
	FEED TIME2	History of paper transport time between sensors 2	Year/month/day hour: min.: sec.	5 digits	5 digits (ms)	5 digits (ms)
	FEED TIME3	History of paper transport time between sensors 3	Year/month/day hour: min.: sec.	5 digits	5 digits (ms)	5 digits (ms)
	FEED TIME4	History of paper transport time between sensors 4	Year/month/day hour: min.: sec.	5 digits	5 digits (ms)	5 digits (ms)
	FEED TIME5	History of paper transport time between sensors 5	Year/month/day hour: min.: sec.	5 digits	5 digits (ms)	5 digits (ms)
	FEED TIME6	History of paper transport time between sensors 6	Year/month/day hour: min.: sec.	5 digits	5 digits (ms)	5 digits (ms)
	FEED TIME7	History of paper transport time between sensors 7	Year/month/day hour: min.: sec.	5 digits	5 digits (ms)	5 digits (ms)
	FEED TIME8	History of paper transport time between sensors 8	Year/month/day hour: min.: sec.	5 digits	5 digits (ms)	5 digits (ms)
	FEED TIME9	History of paper transport time between sensors 9	Year/month/day hour: min.: sec.	5 digits	5 digits (ms)	5 digits (ms)
	FEED TIME10	History of paper transport time between sensors 10	Year/month/day hour: min.: sec.	5 digits	5 digits (ms)	5 digits (ms)

	Item/Display	Content	Occurrence date	Code between sensors	Passing time	Reference passing time
RSPF	FEED TIME1 (SPF)	History of paper transport time between SPF sensors 1	Year/month/day hour: min.: sec.	5 digits	5 digits (ms)	5 digits (ms)
	FEED TIME2 (SPF)	History of paper transport time between SPF sensors 2	Year/month/day hour: min.: sec.	5 digits	5 digits (ms)	5 digits (ms)
	FEED TIME3 (SPF)	History of paper transport time between SPF sensors 3	Year/month/day hour: min.: sec.	5 digits	5 digits (ms)	5 digits (ms)
	FEED TIME4 (SPF)	History of paper transport time between SPF sensors 4	Year/month/day hour: min.: sec.	5 digits	5 digits (ms)	5 digits (ms)
	FEED TIME5 (SPF)	History of paper transport time between SPF sensors 5	Year/month/day hour: min.: sec.	5 digits	5 digits (ms)	5 digits (ms)
	FEED TIME6 (SPF)	History of paper transport time between SPF sensors 6	Year/month/day hour: min.: sec.	5 digits	5 digits (ms)	5 digits (ms)
	FEED TIME7 (SPF)	History of paper transport time between SPF sensors 7	Year/month/day hour: min.: sec.	5 digits	5 digits (ms)	5 digits (ms)
	FEED TIME8 (SPF)	History of paper transport time between SPF sensors 8	Year/month/day hour: min.: sec.	5 digits	5 digits (ms)	5 digits (ms)
	FEED TIME9 (SPF)	History of paper transport time between SPF sensors 9	Year/month/day hour: min.: sec.	5 digits	5 digits (ms)	5 digits (ms)
	FEED TIME10 (SPF)	History of paper transport time between SPF sensors 10	Year/month/day hour: min.: sec.	5 digits	5 digits (ms)	5 digits (ms)

27-14

<b>Purpose</b>	Setting
<b>Function (Purpose)</b>	Used to set the FSS function connection test mode.

**Section**

**Operation/Procedure**

- 1) Enter the set value with 10-key.

0	Disable (Default)
1	Enable

- 2) Press [OK] key.

The set value in step 1) is saved.

27-15

<b>Purpose</b>	Operation test/check
<b>Function (Purpose)</b>	Used to display the FSS connection status.

**Section**

**Operation/Procedure**

The FSS operating status is displayed.

Item/Display	Content	Setting range	Default value
FSS CONNECTION	Used to display the FSS connection status.	0 Not operated	0
		1 Operated	

27-16

<b>Purpose</b>	Setting
<b>Function (Purpose)</b>	Used to set the FSS alert send.

**Section**

**Operation/Procedure**

- 1) Enter the set value with 10-key.  
The value for the FSS alert operation specification is set.
- 2) Press [OK] key.

	Item/Display	Content	Setting range	Default value	
A	MAINTENANCE ALERT (0:YES 1:NO)	Maintenance alert send Enable setting	Alert send Enable	0	0
			Alert send Disable	1	
B	TONER ORDER ALERT (0:YES 1:NO)	Toner order alert send Enable setting	Alert send Enable	0	0
			Alert send Disable	1	
C	TONER CTRG ALERT (0:YES 1:NO)	Toner cartridge replacement alert send Enable setting	Alert send Enable	0	0
			Alert send Disable	1	
D	JAM ALERT (0:YES 1:NO)	Continuous JAM alert send Enable setting	Alert send Enable	0	0
			Alert send Disable	1	
E	TROUBLE ALERT (0:YES 1:NO)	Trouble alert send Enable setting	Alert send Enable	0	0
			Alert send Disable	1	
F	PAPER ORDER ALERT (0:YES 1:NO)	Paper order alert send Enable setting	Alert send Enable	0	0
			Alert send Disable	1	

27-17

<b>Purpose</b>	Setting
<b>Function (Purpose)</b>	Used to set the FSS paper order alert.

**Section**

**Operation/Procedure**

- 1) Select an item to be set.
- 2) Enter the set value with 10-key.  
The value for the FSS paper order alert operation specification is set.
- 3) Press [SET] key.

Item/Display	Content	Setting range	Default value	NOTE
PAPER TYPE SET	Setting of paper kind for paper order alert SET	0 - 2	0	0: Standard paper and recycled paper
				1: Standard paper only
				2: Recycled paper only
A3	Paper order number setting [Number of sheets] (A3)	500 - 5000	1250	Unit: No. of sheets for a box
A4	Paper order number setting [Number of sheets] (A4)	500 - 5000	2500	Unit: No. of sheets for a box
B4	Paper order number setting [Number of sheets] (B4)	500 - 5000	2500	Unit: No. of sheets for a box
B5	Paper order number setting [Number of sheets] (B5)	500 - 5000	2500	Unit: No. of sheets for a box
A3: FIRST	Paper order alert number setting (A3) (Number of used sheets)	500 - 10000	1000	Unit: No. of alert sheets for the first time
A4: FIRST	Paper order alert number setting (A4) (Number of used sheets)	500 - 10000	1000	Unit: No. of alert sheets for the first time
B4: FIRST	Paper order alert number setting (B4) (Number of used sheets)	500 - 10000	1000	Unit: No. of alert sheets for the first time
B5: FIRST	Paper order alert number setting (B5) (Number of used sheets)	500 - 10000	1000	Unit: No. of alert sheets for the first time

<b>27-18</b>	
<b>Purpose</b>	Data clear
<b>Function (Purpose)</b>	Used to clear the FSS paper feed retry counter.

**Section**

**Operation/Procedure**

- 1) Select an item to be cleared.
  - 2) Press [EXECUTE] key.
  - 3) Press [YES] key.
- The target counter is cleared.

Item/Display	Content
TRAY1	Tray 1 paper feed retry counter
TRAY2	Tray 2 paper feed retry counter
TRAY3	Tray 3 paper feed retry counter
TRAY4	Tray 4 paper feed retry counter
MFT	Manual paper feed retry counter
LCC	LCC paper feed retry counter

**30**

<b>30-1</b>	
<b>Purpose</b>	Operation test/check
<b>Function (Purpose)</b>	Used to check the operations of the sensors and the detectors in other than the paper feed section and the control circuits.

**Section**

**Operation/Procedure**

The operating conditions of the sensors and detectors are displayed.

The sensors and the detectors which are turned ON are highlighted.

PPD1	Paper transport detector 1
PPD2	Paper transport detector 2
POD1	Paper exit detector 1
POD2	Paper exit detector 2
POD3	Paper exit detector 3
TFD2	Paper exit tray full detector (Face-down tray)
TFD3	Paper exit tray full detector (Right paper exit tray)
SHPOS	Shifter home positions sensor
DSW_R	ADU open/close detector
DSW_C	Transport cover open/close detector (Paper feed tray 1)
DSW_F	Front cover open/close detector
DHPD_CL	OPC drum rotation sensor (CL)
DHPD_K	OPC drum rotation sensor (BK)
TNFD	Waste toner full detector
HLPCD	Fusing roller pressure detector
DSW_C2	Transport cover open/close detector (Paper feed tray 2)
PRTPD	Paper exit tray paper detector (Right paper exit tray)
1TUD_CL	Transfer mode detector (CL)
1TUD_K	Transfer mode detector (BK)
2TUD	Secondary transfer position detector
WEBEND	Web end detector (36cpm machine)

<b>30-2</b>	
<b>Purpose</b>	Operation test/check
<b>Function (Purpose)</b>	Used to check the operations of the sensors and the detectors in the paper feed section and the control circuits.

**Section**

**Operation/Procedure**

The operating conditions of the sensors and detectors are displayed.

The sensors and the detectors which are turned ON are highlighted.

CPFD1	Paper transport detector (Paper feed tray 1)
CLUD1	Paper feed tray upper limit sensor (Paper feed tray 1)
CPED1	Paper empty sensor (Paper feed tray 1)
CSPD1	Paper remaining quantity sensor (Paper feed tray 1)
CSS11	Paper feed tray size detector (Paper feed tray 1)(*1)
CSS12	
CSS13	
CSS14	
CPFD2	Paper transport detector (Paper feed tray 2)
CLUD2	Paper feed tray upper limit sensor (Paper feed tray 2)
CPED2	Paper empty sensor (Paper feed tray 2)
CSPD2	Paper remaining quantity sensor (Paper feed tray 2)
CSS21	Paper feed tray paper size detector (Paper feed tray 2)
CSS22	
CSS23	
CSS24	
CSS1	Paper feed tray 1 detector
CSS2	Paper feed tray 2 detector (*1)
CSS2SET	Desk installation detection
MPLD	Paper length detector (Manual paper feed tray)
MPED	Paper empty sensor (Manual paper feed tray)

\*1: Displayed, but not installed in some models.

### 33

33-2	
<b>Purpose</b>	Data clear
<b>Function (Purpose)</b>	Used to delete the ID (IDM) information of Felica card. (23cpm/31cpm(G) machine only)
<b>Section</b>	

#### Operation/Procedure

- 1) Press [EXECUTE] key.
- 2) Press [YES] key.  
The ID (IDM) information of Felica card is deleted.

### 40

40-2	
<b>Purpose</b>	Adjustment/Setup
<b>Function (Purpose)</b>	Manual paper feed tray paper width sensor adjustment.
<b>Section</b>	Paper feed

#### Operation/Procedure

- 1) Open the manual paper feed guide to the max. width (MAX).
- 2) Press [EXECUTE] key.  
The max. width (MAX) detection level is recognized.
- 3) Open the manual paper feed guide to P1 width (A4).
- 4) Press [EXECUTE] key.  
The P1 width (A4) detection level is recognized.
- 5) Open the manual paper feed guide to P2 width (A4R).
- 6) Press [EXECUTE] key.  
The P2 width (A4R) detection level is recognized.
- 7) Open the manual paper feed guide to the min. width (MIN).
- 8) Press [EXECUTE] key.  
The min. width (MIN) detection level is recognized.

When the above operation is not performed normally, "ERROR" is displayed. When completed normally, "COMPLETE" is displayed.

MAX POSITION	Manual feed max. width
P1(A4)POSITION	Manual feed P1 position width (A4)
P2(A4R)POSITION	Manual feed P2 position width (A4R)
MIN POSITION	Manual feed min. width

40-7	
<b>Purpose</b>	Adjustment/Setup
<b>Function (Purpose)</b>	Used to set the adjustment value of the manual paper feed tray paper width sensor.
<b>Section</b>	Paper feed

#### Operation/Procedure

- 1) Select a target item to be adjusted with scroll keys.
- 2) Enter the set value with 10-key.
- 3) Press [OK] key.  
The set value in step 2) is saved.

	Item/Display	Content	Default value
A	MAX POSITION	Manual feed max. width	241
B	P1 (A4) POSITION	Manual feed P1 position width (A4)	231
C	P2 (A4R) POSITION	Manual feed P2 position width (A4R)	140
D	MIN POSITION	Manual feed min. width	19

### 41

41-1	
<b>Purpose</b>	Operation test/check
<b>Function (Purpose)</b>	Used to check the operations of the document size sensor and the control circuit.
<b>Section</b>	

#### Operation/Procedure

The operating conditions of the sensors and detectors are displayed.

The sensors and the detectors which are turned ON are highlighted.

OCSW	Document cover status	Open: Normal display Close: Highlighted
PD1 - 7	Document detection sensor status	No document: Normal display Document present: Highlighted

41-2	
<b>Purpose</b>	Adjustment
<b>Function (Purpose)</b>	Used to adjust the document size sensor detection level.
<b>Section</b>	

#### Operation/Procedure

- 1) Open the document cover, and press [EXECUTE] key without place a document on the document table.  
The sensor level without document is recognized.
- 2) Set A3 (11" x 17") paper on the document table, and press [EXECUTE] key.  
The sensor level when detecting the document is displayed.  
When the above operation is normally completed, it is displayed.

41-3	
<b>Purpose</b>	Operation test/check
<b>Function (Purpose)</b>	Used to check the operations of the document size sensor and the control circuit.
<b>Section</b>	

#### Operation/Procedure

The detection output level (A/D value) of OCSW and the document sensor (PD1 - PD7) is displayed in real time.

The light receiving range of PD1 - PD7 is 1 - 255. (Default: 128)

Item/Display	Content	Detection level range
OCSW	Original cover SW	0-1 ("1" to Close)
PD1	Document detection 1	0 - 255
PD2	Document detection 2	0 - 255
PD3	Document detection 3	0 - 255
PD4	Document detection 4	0 - 255
PD5	Document detection 5	0 - 255
PD6	Document detection 6	0 - 255
PD7	Document detection 7	0 - 255



43-1

<b>Purpose</b>	Setting
<b>Function (Purpose)</b>	Used to set the fusing temperature in each mode.

**Section****Operation/Procedure**

- 1) Select an item to be set with scroll keys.
- 2) Enter the set value with 10-key.
- 3) Press [OK] key.  
The set value in step 2) is saved.

**18cpm/20cpm machine**

Item/Display	Content	Setting range	Default value (SW-A)			Default value (SW-B)			
			Group A	Group B	Group C	Group A	Group B	Group C	
A	HL_UM READY	Ready standby TH_UM set value	70 - 230	150	175	175	165	180	180
B	HL_LM READY	Ready standby TH_LM set value	30 - 200	110	110	110	120	120	120
C	HL_US READY	Ready standby TH_US set value	70 - 230	150	165	165	165	170	170
D	HL_UM PLAIN PAPER BW	Black-White plain paper TH_UM set value	70 - 230	135	160	160	150	165	165
E	HL_LM PLAIN PAPER BW	Black-White plain paper TH_LM set value	30 - 200	125	140	140	140	140	140
F	HL_US PLAIN PAPER BW	Black-White plain paper TH_US set value	70 - 230	135	155	155	150	160	160
G	HL_UM PLAIN PAPER CL	Color plain paper TH_UM set value	70 - 230	145	170	170	160	175	175
H	HL_LM PLAIN PAPER CL	Color plain paper TH_LM set value	30 - 200	135	140	140	140	140	140
I	HL_US PLAIN PAPER CL	Color plain paper TH_US set value	70 - 230	145	160	160	160	165	165
J	WARMUP FUMON HL_US T	Fusing motor pre-rotation start TH_US set value	30 - 200	135	135	135	135	135	135
K	WARMUP FUMOFF	Fusing motor previous rotation complete time	0 - 255	30	30	30	30	30	30
L	WARM UP END TIME	Warm-up complete time	1 - 255	38	38	38	38	38	38
M	HL_UM HEAVY PAPER	Heavy paper TH_UM set value	70 - 230	170	170	170	170	170	170
N	HL_LM HEAVY PAPER	Heavy paper TH_LM set value	30 - 200	140	140	140	140	140	140
O	HL_US HEAVY PAPER	Heavy paper TH_US set value	70 - 230	170	170	170	170	170	170
P	HL_UM OHP PAPER	OHP-TH_UM set value	70 - 230	175	175	175	175	175	175
Q	HL_LM OHP PAPER	OHP-TH_LM set value	30 - 200	135	135	135	135	135	135
R	HL_US OHP PAPER	OHP-TH_US set value	70 - 230	175	175	175	175	175	175
S	HL_UM ENV PAPER	Envelope TH_UM set value	70 - 230	180	170	170	180	170	170
T	HL_LM ENV PAPER	Envelope TH_LM set value	30 - 200	145	135	135	145	135	135
U	HL_US ENV PAPER	Envelope TH_US set value	70 - 230	180	170	170	180	170	170
V	HL_UM GLOSS PAPER	Glossy paper TH_UM set value	70 - 230	180	180	180	180	180	180
W	HL_LM GLOSS PAPER	Glossy paper TH_LM set value	30 - 200	140	140	140	140	140	140
X	HL_US GLOSS PAPER	Glossy paper TH_US set value	70 - 230	180	180	180	180	180	180
Y	HL_UM E-STAR	Preheating TH_UM set value	30 - 200	125	125	125	125	125	125
Z	HL_US E-STAR	Preheating TH_US set value	30 - 200	125	125	125	125	125	125
AA	HL_UM PRE-JOB	Preheat mode restore complete temperature	30 - 200	130	130	130	130	130	130
AB	HL_LM E-STAR	Preheating TH_LM set value	30 - 200	115	115	115	115	115	115
AC	HL_UM HEAVY2 PAPER	Heavy paper 2 TH_UM set value	70 - 230	175	175	175	175	175	175
AD	HL_LM HEAVY2 PAPER	Heavy paper 2 TH_LM set value	30 - 200	140	140	140	140	140	140
AE	HL_US HEAVY2 PAPER	Heavy paper 2 TH_SU set value	70 - 230	175	175	175	175	175	175
AF	HL_UM WARMUP_120L	TH_UM set value when Warm-Up at 120°C or below	70 - 230	145	170	170	160	175	175
AG	HL_LM WARMUP_120L	TH_LM set value when Warm-Up at 120°C or below	30 - 200	110	110	110	110	110	110
AH	HL_US WARMUP_120L	TH_US set value when Warm-Up at 120°C or below	70 - 230	135	150	150	150	155	155
AI	LO_WARMUP_TIME	AF - AH applying time (Timer from completion of Ready)	0 - 255	0	0	0	0	0	0
AJ	HL_UM WARMUP_120H	TH_UM set value when Warm-Up at 120°C or above	70 - 230	145	170	170	160	175	175
AK	HL_LM WARMUP_120H	TH_LM set value when Warm-Up at 120°C or above	30 - 200	110	110	110	110	110	110
AL	HL_US WARMUP_120H	TH_US set value when Warm-Up at 120°C or above	70 - 230	135	150	150	150	155	155
AM	HI_WARMUP_TIME	AJ - AL applying time (Timer from completion of Ready)	0 - 255	0	0	0	0	0	0
AN	HI_WU_FM_ON_TMP	FM prior rotation start TH_US when Warm-Up at alpha °C or above	30 - 200	105	105	105	105	105	105
AO	HI_WU_END_TIME	Warm-Up completion time when Warm-Up at alpha °C or above	0 - 255	38	38	38	38	38	38
AP	HI_WU_JOB_SET_TMP	Job enable TH_UM temperature when Warm-Up at alpha °C or above	70 - 230	145	170	170	160	175	175
AQ	HI_WARMUP_BORDER	Threshold value alpha to which SIM43-1-AN - AP is applied	1 - 119	70	70	70	70	70	70
AR	LO_WU_JOB_SET_TMP	Job enable TH_UM temperature when Warm-Up at alpha °C or below	70 - 230	145	170	170	160	175	175

Item/Display		Content	Setting range	Default value (SW-A)			Default value (SW-B)		
				Group A	Group B	Group C	Group A	Group B	Group C
AS	JOBEND_FUMON_TIME	Fusing motor after rotation time after completion of a job (Excluding heavy paper, OPH, and envelopes)	0 - 255	5	5	5	5	5	5
AT	HL_UM_JOB_SET_TMP_B W	Job enable temperature (B/W) when the upper roller temperature is lower than alpha °C	70 - 230	145	170	170	160	175	175

### Code descriptions

TH_UM	Fusing thermistor main (Front surface of paper)	HL_UM	Heater lamp main (Heat roller for front surface of paper)
TH_LM	Fusing thermistor main (Back surface of paper)	HL_LM	Heater lamp main (Heat roller for front surface of paper)
TH_US	Fusing thermistor sub (Front surface of paper)	HL_US	Heater lamp sub (Heat roller for front surface of paper)

SW-A Setting value when plain paper is selected in the system setting/device setting/fusing control setting.

SW-B Set value when heavy paper is selected in the system setting/device setting/fusing control setting.

The set value displayed in this simulation differs depending on plain paper or heavy paper which is selected in the system setting/device setting/fusing control setting.

(Example) When plain paper is selected in the system setting/device setting/fusing control setting, the value of SW-A is displayed.

### List of destination groups

Group	Destination				
Group A	JAPAN	-	-	-	-
Group B	U. S. A	CANADA	INCH	-	-
Group C	EUROPE	U. K	AUS.	AB_B	CHINA

### 23cpm machine

Item/Display		Content	Setting range	Default value (SW-A)			Default value (SW-B)		
				Group A	Group B	Group C	Group A	Group B	Group C
A	HL_UM READY	Ready standby TH_UM set value	70 - 230	95	110	110	125	115	125
B	HL_LM READY	Ready standby TH_LM set value	30 - 200	90	105	105	100	115	115
C	HL_US READY	Ready standby TH_US set value	70 - 230	135	140	140	150	145	150
D	HL_UM PLAIN PAPER BW	Black-White plain paper TH_UM set value	70 - 230	125	125	135	140	130	145
E	HL_LM PLAIN PAPER BW	Black-White plain paper TH_LM set value	30 - 200	110	115	115	110	125	125
F	HL_US PLAIN PAPER BW	Black-White plain paper TH_US set value	70 - 230	135	135	140	150	140	150
G	HL_UM PLAIN PAPER CL	Color plain paper TH_UM set value	70 - 230	125	130	135	140	135	145
H	HL_LM PLAIN PAPER CL	Color plain paper TH_LM set value	30 - 200	110	115	115	110	125	125
I	HL_US PLAIN PAPER CL	Color plain paper TH_US set value	70 - 230	135	140	140	150	145	150
J	WARMUP FUMON HL_US T	Fusing motor pre-rotation start TH_US set value	30 - 200	30	30	30	30	30	30
K	WARMUP FUMOFF	Fusing motor previous rotation complete time	0 - 255	20	20	20	20	20	20
L	WARM UP END TIME	Warm-up complete time	1 - 255	16	16	16	16	16	16
M	HL_UM HEAVY PAPER	Heavy paper TH_UM set value	70 - 230	170	170	170	170	170	170
N	HL_LM HEAVY PAPER	Heavy paper TH_LM set value	30 - 200	120	120	120	120	120	120
O	HL_US HEAVY PAPER	Heavy paper TH_US set value	70 - 230	160	160	160	160	160	160
P	HL_UM OHP PAPER	OHP-TH_UM set value	70 - 230	175	175	175	175	175	175
Q	HL_LM OHP PAPER	OHP-TH_LM set value	30 - 200	125	125	125	125	125	125
R	HL_US OHP PAPER	OHP-TH_US set value	70 - 230	175	175	175	175	175	175
S	HL_UM ENV PAPER	Envelope TH_UM set value	70 - 230	175	175	175	175	175	175
T	HL_LM ENV PAPER	Envelope TH_LM set value	30 - 200	125	125	125	125	125	125
U	HL_US ENV PAPER	Envelope TH_US set value	70 - 230	175	175	175	175	175	175
V	HL_UM GLOSS PAPER	Glossy paper TH_UM set value	70 - 230	180	180	180	180	180	180
W	HL_LM GLOSS PAPER	Glossy paper TH_LM set value	30 - 200	120	120	120	120	120	120
X	HL_US GLOSS PAPER	Glossy paper TH_US set value	70 - 230	180	180	180	180	180	180
Y	HL_UM E-STAR	Preheating TH_UM set value	30 - 200	85	105	100	85	105	100
Z	HL_US E-STAR	Preheating TH_US set value	30 - 200	125	135	130	125	135	130
AA	HL_UM PRE-JOB	Preheat mode restore complete temperature	30 - 200	120	125	130	135	130	140
AB	HL_LM E-STAR	Preheating TH_LM set value	30 - 200	70	90	90	70	90	90
AC	HL_UM HEAVY2 PAPER	Heavy paper 2 TH_UM set value	70 - 230	170	170	170	170	170	170
AD	HL_LM HEAVY2 PAPER	Heavy paper 2 TH_LM set value	30 - 200	120	120	120	120	120	120
AE	HL_US HEAVY2 PAPER	Heavy paper 2 TH_US set value	70 - 230	160	160	160	160	160	160
AF	HL_UM WARMUP_120L	TH_UM set value when Warm-Up at 120°C or below	70 - 230	135	145	145	140	140	145
AG	HL_LM WARMUP_120L	TH_LM set value when Warm-Up at 120°C or below	30 - 200	90	105	105	100	115	115
AH	HL_US WARMUP_120L	TH_US set value when Warm-Up at 120°C or below	70 - 230	125	135	135	135	135	145
AI	LO_WARMUP_TIME	AF - AH applying time (Timer from completion of Ready)	0 - 255	0	0	0	0	0	0
AJ	HL_UM WARMUP_120H	TH_UM set value when Warm-Up at 120°C or above	70 - 230	135	145	145	140	140	145
AK	HL_LM WARMUP_120H	TH_LM set value when Warm-Up at 120°C or above	30 - 200	90	105	105	100	115	115
AL	HL_US WARMUP_120H	TH_US set value when Warm-Up at 120°C or above	70 - 230	125	135	135	135	135	145
AM	HI_WARMUP_TIME	AJ - AL applying time (Timer from completion of Ready)	0 - 255	0	0	0	0	0	0

Item/Display	Content	Setting range	Default value (SW-A)			Default value (SW-B)		
			Group A	Group B	Group C	Group A	Group B	Group C
AN	HI_WU_FM_ON_TMP	FM prior rotation start TH_US when Warm-Up at alpha °C or above	30 - 200	30	30	30	30	30
AO	HI_WU_END_TIME	Warm-Up completion time when Warm-Up at alpha °C or above	0 - 255	16	16	16	16	16
AP	HI_WU_JOB_SET_TMP	Job enable TH_UM temperature when Warm-Up at alpha °C or above	70 - 230	135	145	145	140	145
AQ	HI_WARMUP_BORDER	Threshold value alpha to which SIM43-1-AN - AP is applied	1 - 119	70	70	70	70	70
AR	LO_WU_JOB_SET_TMP	Job enable TH_UM temperature when Warm-Up at alpha °C or below	70 - 230	135	145	145	140	145
AS	JOBEND_FUMON_TIME	Fusing motor after rotation time after completion of a job (Excluding heavy paper, OPH, and envelopes)	0 - 255	5	5	5	5	5
AT	HL_UM_JOB_SET_TMP_BW	Job enable temperature (B/W) when the upper roller temperature is lower than alpha °C	70 - 230	135	145	145	140	145

### Code descriptions

TH_UM	Fusing thermistor main (Front surface of paper)	HL_UM	Heater lamp main (Heat roller for front surface of paper)
TH_LM	Fusing thermistor main (Back surface of paper)	HL_LM	Heater lamp main (Heat roller for front surface of paper)
TH_US	Fusing thermistor sub (Front surface of paper)	HL_US	Heater lamp sub (Heat roller for front surface of paper)

SW-A Setting value when plain paper is selected in the system setting/device setting/fusing control setting.

SW-B Set value when heavy paper is selected in the system setting/device setting/fusing control setting.

The set value displayed in this simulation differs depending on plain paper or heavy paper which is selected in the system setting/device setting/fusing control setting.

(Example) When plain paper is selected in the system setting/device setting/fusing control setting, the value of SW-A is displayed.

### List of destination groups

Group	Destination				
Group A	JAPAN	–	–	–	–
Group B	U. S. A	CANADA	INCH	–	–
Group C	EUROPE	U. K	AUS.	AB_B	CHINA

### 26cpm/31cpm machine

Item/Display	Content	Setting range	Default value (SW-A)			Default value (SW-B)		
			Group A	Group B	Group C	Group A	Group B	Group C
A	HL_UM READY	Ready standby TH_UM set value	70 - 230	95	110	110	120	125
B	HL_LM READY	Ready standby TH_LM set value	30 - 200	90	105	105	100	115
C	HL_US READY	Ready standby TH_US set value	70 - 230	145	150	155	155	160
D	HL_UM PLAIN PAPER BW	Black-White plain paper TH_UM set value	70 - 230	125	125	135	130	135
E	HL_LM PLAIN PAPER BW	Black-White plain paper TH_LM set value	30 - 200	110	115	115	110	125
F	HL_US PLAIN PAPER BW	Black-White plain paper TH_US set value	70 - 230	145	145	155	150	155
G	HL_UM PLAIN PAPER CL	Color plain paper TH_UM set value	70 - 230	125	130	135	140	145
H	HL_LM PLAIN PAPER CL	Color plain paper TH_LM set value	30 - 200	110	115	115	110	125
I	HL_US PLAIN PAPER CL	Color plain paper TH_US set value	70 - 230	145	150	155	155	160
J	WARMUP FUMON HL_US T	Fusing motor pre-rotation start TH_US set value	30 - 200	30	30	30	30	30
K	WARMUP FUMOFF	Fusing motor previous rotation complete time	0 - 255	20	20	20	20	20
L	WARM UP END TIME	Warm-up complete time	1 - 255	16	16	16	16	16
M	HL_UM HEAVY PAPER	Heavy paper TH_UM set value	70 - 230	160	160	160	160	160
N	HL_LM HEAVY PAPER	Heavy paper TH_LM set value	30 - 200	120	120	120	120	120
O	HL_US HEAVY PAPER	Heavy paper TH_US set value	70 - 230	150	150	150	150	150
P	HL_UM OHP PAPER	OHP-TH_UM set value	70 - 230	175	175	175	175	175
Q	HL_LM OHP PAPER	OHP-TH_LM set value	30 - 200	125	125	125	125	125
R	HL_US OHP PAPER	OHP-TH_US set value	70 - 230	175	175	175	175	175
S	HL_UM ENV PAPER	Envelope TH_UM set value	70 - 230	175	175	175	175	175
T	HL_LM ENV PAPER	Envelope TH_LM set value	30 - 200	125	125	125	125	125
U	HL_US ENV PAPER	Envelope TH_US set value	70 - 230	175	175	175	175	175
V	HL_UM GLOSS PAPER	Glossy paper TH_UM set value	70 - 230	180	180	180	180	180
W	HL_LM GLOSS PAPER	Glossy paper TH_LM set value	30 - 200	120	120	120	120	120
X	HL_US GLOSS PAPER	Glossy paper TH_US set value	70 - 230	180	180	180	180	180
Y	HL_UM E-STAR	Preheating TH_UM set value	30 - 200	90	105	100	90	105
Z	HL_US E-STAR	Preheating TH_US set value	30 - 200	130	135	130	130	135
AA	HL_UM PRE-JOB	Preheat mode restore complete temperature	30 - 200	120	125	130	135	140
AB	HL_LM E-STAR	Preheating TH_LM set value	30 - 200	70	90	90	70	90
AC	HL_UM HEAVY2 PAPER	Heavy paper 2 TH_UM set value	70 - 230	170	170	170	170	170
AD	HL_LM HEAVY2 PAPER	Heavy paper 2 TH_LM set value	30 - 200	120	120	120	120	120
AE	HL_US HEAVY2 PAPER	Heavy paper 2 TH_SU set value	70 - 230	160	160	160	160	160
AF	HL_UM WARMUP_120L	TH_UM set value when Warm-Up at 120°C or below	70 - 230	135	140	145	140	150

Item/Display		Content	Setting range	Default value (SW-A)			Default value (SW-B)		
				Group A	Group B	Group C	Group A	Group B	Group C
AG	HL_LM WARMUP_120L	TH_LM set value when Warm-Up at 120°C or below	30 - 200	90	105	105	100	115	115
AH	HL_US WARMUP_120L	TH_US set value when Warm-Up at 120°C or below	70 - 230	135	140	150	150	140	155
AI	LO_WARMUP_TIME	AF - AH applying time (Timer from completion of Ready)	0 - 255	0	0	0	0	0	0
AJ	HL_UM WARMUP_120H	TH_UM set value when Warm-Up at 120°C or above	70 - 230	135	140	145	140	140	150
AK	HL_LM WARMUP_120H	TH_LM set value when Warm-Up at 120°C or above	30 - 200	90	105	105	100	115	115
AL	HL_US WARMUP_120H	TH_US set value when Warm-Up at 120°C or above	70 - 230	135	140	150	150	140	155
AM	HI_WARMUP_TIME	AJ - AL applying time (Timer from completion of Ready)	0 - 255	0	0	0	0	0	0
AN	HI_WU_FM_ON_TMP	FM prior rotation start TH_US when Warm-Up at alpha °C or above	30 - 200	30	30	30	30	30	30
AO	HI_WU_END_TIME	Warm-Up completion time when Warm-Up at alpha °C or above	0 - 255	16	16	16	16	16	16
AP	HI_WU_JOB_SET_TMP	Job enable TH_UM temperature when Warm-Up at alpha °C or above	70 - 230	135	140	145	140	140	150
AQ	HI_WARMUP_BORDER	Threshold value alpha to which SIM43-1-AN - AP is applied	1 - 119	70	70	70	70	70	70
AR	LO_WU_JOB_SET_TMP	Job enable TH_UM temperature when Warm-Up at alpha °C or below	70 - 230	135	140	145	140	140	150
AS	JOBEND_FUMON_TIME	Fusing motor after rotation time after completion of a job (Excluding heavy paper, OPH, and envelopes)	0 - 255	5	5	5	5	5	5
AT	HL_UM_JOB_SET_TMP_BW	Job enable temperature (B/W) when the upper roller temperature is lower than alpha °C	70 - 230	135	140	145	140	140	150

### Code descriptions

TH_UM	Fusing thermistor main (Front surface of paper)	HL_UM	Heater lamp main (Heat roller for front surface of paper)
TH_LM	Fusing thermistor main (Back surface of paper)	HL_LM	Heater lamp main (Heat roller for front surface of paper)
TH_US	Fusing thermistor sub (Front surface of paper)	HL_US	Heater lamp sub (Heat roller for front surface of paper)

SW-A Setting value when plain paper is selected in the system setting/device setting/fusing control setting.

SW-B Set value when heavy paper is selected in the system setting/device setting/fusing control setting.

The set value displayed in this simulation differs depending on plain paper or heavy paper which is selected in the system setting/device setting/fusing control setting.

(Example) When plain paper is selected in the system setting/device setting/fusing control setting, the value of SW-A is displayed.

### List of destination groups

Group	Destination				
Group A	JAPAN	-	-	-	-
Group B	U. S. A	CANADA	INCH	-	-
Group C	EUROPE	U. K	AUS.	AB_B	CHINA

### 36cpm machine

Item/Display		Content	Setting range	Default value (SW-A)			Default value (SW-B)		
				Group A	Group B	Group C	Group A	Group B	Group C
A	HL_UM READY	Ready standby TH_UM set value	70 - 230	100	120	125	125	130	140
B	HL_LM READY	Ready standby TH_LM set value	30 - 200	90	105	105	110	115	115
C	HL_US READY	Ready standby TH_US set value	70 - 230	145	155	160	155	170	170
D	HL_UM PLAIN PAPER BW	Black-White plain paper TH_UM set value	70 - 230	125	130	145	130	140	145
E	HL_LM PLAIN PAPER BW	Black-White plain paper TH_LM set value	30 - 200	110	115	115	120	125	125
F	HL_US PLAIN PAPER BW	Black-White plain paper TH_US set value	70 - 230	140	145	160	145	155	160
G	HL_UM PLAIN PAPER CL	Color plain paper TH_UM set value	70 - 230	130	140	150	145	150	160
H	HL_LM PLAIN PAPER CL	Color plain paper TH_LM set value	30 - 200	110	115	115	120	125	125
I	HL_US PLAIN PAPER CL	Color plain paper TH_US set value	70 - 230	145	155	160	155	170	170
J	WARMUP FUMON HL_US T	Fusing motor pre-rotation start TH_US set value	30 - 200	30	30	30	30	30	30
K	WARMUP FUMOFF	Fusing motor previous rotation complete time	0 - 255	20	20	20	20	20	20
L	WARM UP END TIME	Warm-up complete time	1 - 255	16	16	16	16	16	16
M	HL_UM HEAVY PAPER	Heavy paper TH_UM set value	70 - 230	160	160	160	160	160	160
N	HL_LM HEAVY PAPER	Heavy paper TH_LM set value	30 - 200	120	120	120	120	120	120
O	HL_US HEAVY PAPER	Heavy paper TH_US set value	70 - 230	150	150	150	150	150	150
P	HL_UM OHP PAPER	OHP-TH_UM set value	70 - 230	175	175	175	175	175	175
Q	HL_LM OHP PAPER	OHP-TH_LM set value	30 - 200	125	125	125	125	125	125
R	HL_US OHP PAPER	OHP-TH_US set value	70 - 230	175	175	175	175	175	175
S	HL_UM ENV PAPER	Envelope TH_UM set value	70 - 230	175	175	175	175	175	175
T	HL_LM ENV PAPER	Envelope TH_LM set value	30 - 200	125	125	125	125	125	125
U	HL_US ENV PAPER	Envelope TH_US set value	70 - 230	175	175	175	175	175	175
V	HL_UM GLOSS PAPER	Glossy paper TH_UM set value	70 - 230	180	180	180	180	180	180
W	HL_LM GLOSS PAPER	Glossy paper TH_LM set value	30 - 200	120	120	120	120	120	120

Item/Display		Content	Setting range	Default value (SW-A)			Default value (SW-B)		
				Group A	Group B	Group C	Group A	Group B	Group C
X	HL_US GLOSS PAPER	Glossy paper TH_US set value	70 - 230	180	180	180	180	180	180
Y	HL_UM E-STAR	Preheating TH_UM set value	30 - 200	100	120	115	100	120	115
Z	HL_US E-STAR	Preheating TH_US set value	30 - 200	145	155	150	145	155	150
AA	HL_UM PRE-JOB	Preheat mode restore complete temperature	30 - 200	135	135	145	140	145	155
AB	HL_LM E-STAR	Preheating TH_LM set value	30 - 200	70	90	90	70	90	90
AC	HL_UM HEAVY2 PAPER	Heavy paper 2 TH_UM set value	70 - 230	170	170	170	170	170	170
AD	HL_LM HEAVY2 PAPER	Heavy paper 2 TH_LM set value	30 - 200	120	120	120	120	120	120
AE	HL_US HEAVY2 PAPER	Heavy paper 2 TH_SU set value	70 - 230	170	170	170	170	170	170
AF	HL_UM WARMUP_120L	TH_UM set value when Warm-Up at 120°C or below	70 - 230	140	150	160	145	160	165
AG	HL_LM WARMUP_120L	TH_LM set value when Warm-Up at 120°C or below	30 - 200	90	105	105	110	115	115
AH	HL_US WARMUP_120L	TH_US set value when Warm-Up at 120°C or below	70 - 230	130	140	160	135	160	165
AI	LO_WARMUP_TIME	AF - AH applying time (Timer from completion of Ready)	0 - 255	10	10	10	10	10	10
AJ	HL_UM WARMUP_120H	TH_UM set value when Warm-Up at 120°C or above	70 - 230	140	150	160	145	160	165
AK	HL_LM WARMUP_120H	TH_LM set value when Warm-Up at 120°C or above	30 - 200	90	105	105	110	115	115
AL	HL_US WARMUP_120H	TH_US set value when Warm-Up at 120°C or above	70 - 230	130	140	160	135	160	165
AM	HI_WARMUP_TIME	AJ - AL applying time (Timer from completion of Ready)	0 - 255	10	10	10	10	10	10
AN	HI_WU_FM_ON_TMP	FM prior rotation start TH_US when Warm-Up at alpha °C or above	30 - 200	30	30	30	30	30	30
AO	HI_WU_END_TIME	Warm-Up completion time when Warm-Up at alpha °C or above	0 - 255	16	16	16	16	16	16
AP	HI_WU_JOB_SET_TMP	Job enable TH_UM temperature when Warm-Up at alpha °C or above	70 - 230	140	150	160	145	160	165
AQ	HI_WARMUP_BORDER	Threshold value alpha to which SIM43-1-AN - AP is applied	1 - 119	70	70	70	70	70	70
AR	LO_WU_JOB_SET_TMP	Job enable TH_UM temperature when Warm-Up at alpha °C or below	70 - 230	140	150	160	145	160	165
AS	JOBEND_FUMON_TIME	Fusing motor after rotation time after completion of a job (Excluding heavy paper, OPH, and envelopes)	0 - 255	5	5	5	5	5	5
AT	HL_UM_JOB_SET_TMP_BW	Job enable temperature (B/W) when the upper roller temperature is lower than alpha °C	70 - 230	140	150	160	145	160	165

#### Code descriptions

TH_UM	Fusing thermistor main (Front surface of paper)	HL_UM	Heater lamp main (Heat roller for front surface of paper)
TH_LM	Fusing thermistor main (Back surface of paper)	HL_LM	Heater lamp main (Heat roller for front surface of paper)
TH_US	Fusing thermistor sub (Front surface of paper)	HL_US	Heater lamp sub (Heat roller for front surface of paper)

SW-A Setting value when plain paper is selected in the system setting/device setting/fusing control setting.

SW-B Set value when heavy paper is selected in the system setting/device setting/fusing control setting.

The set value displayed in this simulation differs depending on plain paper or heavy paper which is selected in the system setting/device setting/fusing control setting.

(Example) When plain paper is selected in the system setting/device setting/fusing control setting, the value of SW-A is displayed.

#### List of destination groups

Group	Destination				
Group A	JAPAN	-	-	-	-
Group B	U. S. A	CANADA	INCH	-	-
Group C	EUROPE	U. K	AUS.	AB_B	CHINA

<b>Purpose</b>	Setting
<b>Function (Purpose)</b>	Used to set the fusing temperature 2 in each mode. (Continued from SIM 43-1.)

**Section****Operation/Procedure**

- 1) Select an item to be set with scroll keys.
  - 2) Enter the set value with 10-key.
  - 3) Press [OK] key.
- The set value in step 2) is saved.

**18cpm/20cpm machine**

	Item/Display	Content	Setting range	Default value (SW-A)			Default value (SW-B)		
				Group A	Group B	Group C	Group A	Group B	Group C
A	HL_UM PLAIN PAPER BW DUP	Black-White plain paper duplex TH_UM set value	70 - 230	135	160	160	150	165	165
B	HL_LM PLAIN PAPER BW DUP	Black-White plain paper duplex TH_LM set value	30 - 200	125	140	140	140	140	140
C	HL_US PLAIN PAPER BW DUP	Black-White plain paper duplex TH_US set value	70 - 230	135	155	155	150	155	155
D	PLAIN PAPER BW DUP APP CNT	Black and white plain paper duplex applying number of sheets	0 - 60	0	0	0	0	0	0
E	HL_UM PLAIN PAPER CL DUP	Color plain paper duplex TH_UM set value	70 - 230	145	170	170	160	175	175
F	HL_LM PLAIN PAPER CL DUP	Color plain paper duplex TH_LM set value	30 - 200	135	140	140	140	140	140
G	HL_US PLAIN PAPER CL DUP	Color plain paper duplex TH_US set value	70 - 230	145	160	160	160	165	165
H	PLAIN PAPER CL DUP APP CNT	Color plain paper duplex applying number of sheets	0 - 60	0	0	0	0	0	0
I	HL_UM HEAVY PAPER BW DUP	Black-White heavy paper duplex TH_UM set value	70 - 230	170	170	170	170	170	170
J	HL_LM HEAVY PAPER BW DUP	Black-White heavy paper duplex TH_LM set value	30 - 200	140	140	140	140	140	140
K	HL_US HEAVY PAPER BW DUP	Black-White heavy paper duplex TH_US set value	70 - 230	170	170	170	170	170	170
L	HEAVY PAPER BW DUP APP CNT	Black and white heavy paper duplex applying number of sheets	0 - 60	0	0	0	0	0	0
M	HL_UM HEAVY PAPER CL DUP	Color heavy paper duplex TH_UM set value	70 - 230	170	170	170	170	170	170
N	HL_LM HEAVY PAPER CL DUP	Color heavy paper duplex TH_LM set value	30 - 200	140	140	140	140	140	140
O	HL_US HEAVY PAPER CL DUP	Color heavy paper duplex TH_US set value	70 - 230	170	170	170	170	170	170
P	HEAVY PAPER CL DUP APP CNT	Color heavy paper duplex applying number of sheets	0 - 60	0	0	0	0	0	0

**Code descriptions**

TH_UM	Fusing thermistor main (Front surface of paper)	HL_UM	Heater lamp main (Heat roller for front surface of paper)
TH_LM	Fusing thermistor main (Back surface of paper)	HL_LM	Heater lamp main (Heat roller for front surface of paper)
TH_US	Fusing thermistor sub (Front surface of paper)	HL_US	Heater lamp sub (Heat roller for front surface of paper)

SW-A Setting value when plain paper is selected in the system setting/device setting/fusing control setting.

SW-B Set value when heavy paper is selected in the system setting/device setting/fusing control setting.

The set value displayed in this simulation differs depending on plain paper or heavy paper which is selected in the system setting/device setting/fusing control setting.

(Example) When plain paper is selected in the system setting/device setting/fusing control setting, the value of SW-A is displayed.

**List of destination groups**

Group	Destination				
Group A	JAPAN	-	-	-	-
Group B	U. S. A	CANADA	INCH	-	-
Group C	EUROPE	U. K	AUS.	AB_B	CHINA

**23cpm machine**

	Item/Display	Content	Setting range	Default value (SW-A)			Default value (SW-B)		
				Group A	Group B	Group C	Group A	Group B	Group C
A	HL_UM PLAIN PAPER BW DUP	Black-White plain paper duplex TH_UM set value	70 - 230	125	135	135	140	140	145
B	HL_LM PLAIN PAPER BW DUP	Black-White plain paper duplex TH_LM set value	30 - 200	110	115	115	110	125	125
C	HL_US PLAIN PAPER BW DUP	Black-White plain paper duplex TH_US set value	70 - 230	135	145	140	150	150	155
D	PLAIN PAPER BW DUP APP CNT	Black and white plain paper duplex applying number of sheets	0 - 60	0	0	0	0	0	0
E	HL_UM PLAIN PAPER CL DUP	Color plain paper duplex TH_UM set value	70 - 230	125	135	135	140	140	150
F	HL_LM PLAIN PAPER CL DUP	Color plain paper duplex TH_LM set value	30 - 200	110	115	115	110	125	125
G	HL_US PLAIN PAPER CL DUP	Color plain paper duplex TH_US set value	70 - 230	135	145	140	150	150	155
H	PLAIN PAPER CL DUP APP CNT	Color plain paper duplex applying number of sheets	0 - 60	0	0	0	0	0	0
I	HL_UM HEAVY PAPER BW DUP	Black-White heavy paper duplex TH_UM set value	70 - 230	170	170	170	170	170	170

Item/Display	Content	Setting range	Default value (SW-A)			Default value (SW-B)			
			Group A	Group B	Group C	Group A	Group B	Group C	
J	HL_LM HEAVY PAPER BW DUP	Black-White heavy paper duplex TH_LM set value	30 - 200	120	120	120	120	120	120
K	HL_US HEAVY PAPER BW DUP	Black-White heavy paper duplex TH_US set value	70 - 230	160	160	160	160	160	160
L	HEAVY PAPER BW DUP APP CNT	Black and white heavy paper duplex applying number of sheets	0 - 60	0	0	0	0	0	0
M	HL_UM HEAVY PAPER CL DUP	Color heavy paper duplex TH_UM set value	70 - 230	170	170	170	170	170	170
N	HL_LM HEAVY PAPER CL DUP	Color heavy paper duplex TH_LM set value	30 - 200	120	120	120	120	120	120
O	HL_US HEAVY PAPER CL DUP	Color heavy paper duplex TH_US set value	70 - 230	160	160	160	160	160	160
P	HEAVY PAPER CL DUP APP CNT	Color heavy paper duplex applying number of sheets	0 - 60	0	0	0	0	0	0

#### Code descriptions

TH_UM	Fusing thermistor main (Front surface of paper)	HL_UM	Heater lamp main (Heat roller for front surface of paper)
TH_LM	Fusing thermistor main (Back surface of paper)	HL_LM	Heater lamp main (Heat roller for front surface of paper)
TH_US	Fusing thermistor sub (Front surface of paper)	HL_US	Heater lamp sub (Heat roller for front surface of paper)

SW-A Setting value when plain paper is selected in the system setting/device setting/fusing control setting.

SW-B Set value when heavy paper is selected in the system setting/device setting/fusing control setting.

The set value displayed in this simulation differs depending on plain paper or heavy paper which is selected in the system setting/device setting/fusing control setting.

(Example) When plain paper is selected in the system setting/device setting/fusing control setting, the value of SW-A is displayed.

#### List of destination groups

Group	Destination				
Group A	JAPAN	–	–	–	–
Group B	U. S. A	CANADA	INCH	–	–
Group C	EUROPE	U. K	AUS.	AB_B	CHINA

#### 26cpm/31cpm machine

Item/Display	Content	Setting range	Default value (SW-A)			Default value (SW-B)			
			Group A	Group B	Group C	Group A	Group B	Group C	
A	HL_UM PLAIN PAPER BW DUP	Black-White plain paper duplex TH_UM set value	70 - 230	125	125	135	130	135	135
B	HL_LM PLAIN PAPER BW DUP	Black-White plain paper duplex TH_LM set value	30 - 200	110	115	115	110	125	125
C	HL_US PLAIN PAPER BW DUP	Black-White plain paper duplex TH_US set value	70 - 230	145	145	155	150	155	160
D	PLAIN PAPER BW DUP APP CNT	Black and white plain paper duplex applying number of sheets	0 - 60	0	0	0	0	0	0
E	HL_UM PLAIN PAPER CL DUP	Color plain paper duplex TH_UM set value	70 - 230	125	130	135	140	145	145
F	HL_LM PLAIN PAPER CL DUP	Color plain paper duplex TH_LM set value	30 - 200	110	115	115	110	125	125
G	HL_US PLAIN PAPER CL DUP	Color plain paper duplex TH_US set value	70 - 230	145	150	155	155	165	165
H	PLAIN PAPER CL DUP APP CNT	Color plain paper duplex applying number of sheets	0 - 60	0	0	0	0	0	0
I	HL_UM HEAVY PAPER BW DUP	Black-White heavy paper duplex TH_UM set value	70 - 230	170	170	170	170	170	170
J	HL_LM HEAVY PAPER BW DUP	Black-White heavy paper duplex TH_LM set value	30 - 200	120	120	120	120	120	120
K	HL_US HEAVY PAPER BW DUP	Black-White heavy paper duplex TH_US set value	70 - 230	160	160	160	160	160	160
L	HEAVY PAPER BW DUP APP CNT	Black and white heavy paper duplex applying number of sheets	0 - 60	0	0	0	0	0	0
M	HL_UM HEAVY PAPER CL DUP	Color heavy paper duplex TH_UM set value	70 - 230	170	170	170	170	170	170
N	HL_LM HEAVY PAPER CL DUP	Color heavy paper duplex TH_LM set value	30 - 200	120	120	120	120	120	120
O	HL_US HEAVY PAPER CL DUP	Color heavy paper duplex TH_US set value	70 - 230	160	160	160	160	160	160
P	HEAVY PAPER CL DUP APP CNT	Color heavy paper duplex applying number of sheets	0 - 60	0	0	0	0	0	0

#### Code descriptions

TH_UM	Fusing thermistor main (Front surface of paper)	HL_UM	Heater lamp main (Heat roller for front surface of paper)
TH_LM	Fusing thermistor main (Back surface of paper)	HL_LM	Heater lamp main (Heat roller for front surface of paper)
TH_US	Fusing thermistor sub (Front surface of paper)	HL_US	Heater lamp sub (Heat roller for front surface of paper)

SW-A Setting value when plain paper is selected in the system setting/device setting/fusing control setting.

SW-B Set value when heavy paper is selected in the system setting/device setting/fusing control setting.

The set value displayed in this simulation differs depending on plain paper or heavy paper which is selected in the system setting/device setting/fusing control setting.

(Example) When plain paper is selected in the system setting/device setting/fusing control setting, the value of SW-A is displayed.

#### List of destination groups

Group	Destination				
Group A	JAPAN	–	–	–	–
Group B	U. S. A	CANADA	INCH	–	–
Group C	EUROPE	U. K	AUS.	AB_B	CHINA

### 36cpm machine

Item/Display	Content	Setting range	Default value (SW-A)			Default value (SW-B)			
			Group A	Group B	Group C	Group A	Group B	Group C	
A	HL_UM PLAIN PAPER BW DUP	Black-White plain paper duplex TH_UM set value	70 - 230	125	130	145	130	140	145
B	HL_LM PLAIN PAPER BW DUP	Black-White plain paper duplex TH_LM set value	30 - 200	110	115	115	120	125	125
C	HL_US PLAIN PAPER BW DUP	Black-White plain paper duplex TH_US set value	70 - 230	140	145	160	145	155	160
D	PLAIN PAPER BW DUP APP CNT	Black and white plain paper duplex applying number of sheets	0 - 60	0	0	0	0	0	0
E	HL_UM PLAIN PAPER CL DUP	Color plain paper duplex TH_UM set value	70 - 230	130	140	150	145	150	160
F	HL_LM PLAIN PAPER CL DUP	Color plain paper duplex TH_LM set value	30 - 200	110	115	115	120	125	125
G	HL_US PLAIN PAPER CL DUP	Color plain paper duplex TH_US set value	70 - 230	145	155	160	155	170	170
H	PLAIN PAPER CL DUP APP CNT	Color plain paper duplex applying number of sheets	0 - 60	0	0	0	0	0	0
I	HL_UM HEAVY PAPER BW DUP	Black-White heavy paper duplex TH_UM set value	70 - 230	170	170	170	170	170	170
J	HL_LM HEAVY PAPER BW DUP	Black-White heavy paper duplex TH_LM set value	30 - 200	120	120	120	120	120	120
K	HL_US HEAVY PAPER BW DUP	Black-White heavy paper duplex TH_US set value	70 - 230	160	160	160	160	160	160
L	HEAVY PAPER BW DUP APP CNT	Black and white heavy paper duplex applying number of sheets	0 - 60	0	0	0	0	0	0
M	HL_UM HEAVY PAPER CL DUP	Color heavy paper duplex TH_UM set value	70 - 230	170	170	170	170	170	170
N	HL_LM HEAVY PAPER CL DUP	Color heavy paper duplex TH_LM set value	30 - 200	120	120	120	120	120	120
O	HL_US HEAVY PAPER CL DUP	Color heavy paper duplex TH_US set value	70 - 230	160	160	160	160	160	160
P	HEAVY PAPER CL DUP APP CNT	Color heavy paper duplex applying number of sheets	0 - 60	0	0	0	0	0	0

### Code descriptions

TH_UM	Fusing thermistor main (Front surface of paper)	HL_UM	Heater lamp main (Heat roller for front surface of paper)
TH_LM	Fusing thermistor main (Back surface of paper)	HL_LM	Heater lamp main (Heat roller for front surface of paper)
TH_US	Fusing thermistor sub (Front surface of paper)	HL_US	Heater lamp sub (Heat roller for front surface of paper)

SW-A Setting value when plain paper is selected in the system setting/device setting/fusing control setting.

SW-B Set value when heavy paper is selected in the system setting/device setting/fusing control setting.

The set value displayed in this simulation differs depending on plain paper or heavy paper which is selected in the system setting/device setting/fusing control setting.

(Example) When plain paper is selected in the system setting/device setting/fusing control setting, the value of SW-A is displayed.

### List of destination groups

Group	Destination				
Group A	JAPAN	—	—	—	—
Group B	U. S. A	CANADA	INCH	—	—
Group C	EUROPE	U. K	AUS.	AB_B	CHINA



<b>Purpose</b>	Adjustment/Setup
<b>Function (Purpose)</b>	Used to set the environmental correction under low temperature and low humidity (L/L) for the fusing temperature setting (SIM 43-1) in each paper mode.

**Section****Operation/Procedure**

- 1) Select an item to be set with scroll keys.
- 2) Enter the set value with 10-key.
- 3) Press [OK] key.  
The set value in step 2) is saved.

Correction value: -49 - +49, Input value: Actually inputted value (1 - 99)

Correction value	-49	-25	-5	0	5	25	49
Input value	1	25	45	50	55	75	99

**18cpm/20cpm machine**

	Item/Display	Content	Setting range	Default value
A	HL_UM READY LL	Correction value for TH_UM set value in Ready standby under LL environment	1 - 99	55
B	HL_LM READY LL	Correction value for TH_LM set value in Ready standby under LL environment	1 - 99	55
C	HL_US READY LL	Correction value for TH_US set value in Ready standby under LL environment	1 - 99	55
D	HL_UM PLAIN BW LL	Correction value for Black-White plain paper TH_UM set value under LL environment	1 - 99	55
E	HL_LM PLAIN BW LL	Correction value for Black-White plain paper TH_LM set value under LL environment	1 - 99	55
F	HL_US PLAIN BW LL	Correction value for Black-White plain paper TH_US set value under LL environment	1 - 99	55
G	HL_UM PLAIN CL LL	Correction value for Color plain paper TH_UM set value under LL environment	1 - 99	55
H	HL_LM PLAIN CL LL	Correction value for Color plain paper TH_LM set value under LL environment	1 - 99	55
I	HL_US PLAIN CL LL	Correction value for Color plain paper TH_US set value under LL environment	1 - 99	55
J	WARMUP FUMON HL_US T LL	Correction value for fusing motor pre-rotation start TH_US set value under LL environment	1 - 99	40
K	WARMUP FUMOFF LL	Fusing motor prior rotation completion time under LL environment	1 - 99	50
L	WARMUP END TIME LL	Correction value for warm-up complete time under LL environment	1 - 99	80
M	HL_UM HEAVY LL	Correction value for heavy paper TH_UM set value under LL environment	1 - 99	55
N	HL_LM HEAVY LL	Correction value for heavy paper TH_LM set value under LL environment	1 - 99	55
O	HL_US HEAVY LL	Correction value for heavy paper TH_US set value under LL environment	1 - 99	55
P	HL_UM OHP LL	Correction value for OHP TH_UM set value under LL environment	1 - 99	55
Q	HL_LM OHP LL	Correction value for OHP TH_LM set value under LL environment	1 - 99	55
R	HL_US OHP LL	Correction value for OHP TH_US set value under LL environment	1 - 99	55
S	HL_UM ENVELOPE LL	Correction value for envelope TH_UM set value under LL environment	1 - 99	55
T	HL_LM ENVELOPE LL	Correction value for envelope TH_LM set value under LL environment	1 - 99	55
U	HL_US ENVELOPE LL	Correction value for envelope TH_US set value under LL environment	1 - 99	55
V	HL_UM GLOSS LL	Correction value for glossy paper TH_UM set value under LL environment	1 - 99	55
W	HL_LM GLOSS LL	Correction value for glossy paper TH_LM set value under LL environment	1 - 99	55
X	HL_US GLOSS LL	Correction value for glossy paper TH_US set value under LL environment	1 - 99	55
Y	HL_UM E-STAR LL	Correction value for preheating TH_UM set value under LL environment	1 - 99	55
Z	HL_US E-STAR LL	Correction value for preheating TH_US set value under LL environment	1 - 99	55
AA	HL_UM PRE-JOB LL	Correction value for the set value of TH_UM when restoring from preheating under LL environment	1 - 99	55
AB	HL_LM E-STAR LL	Correction value for preheating TH_LM set value under LL environment	1 - 99	55
AC	HL_UM HEAVY2 CL LL	Correction value for heavy paper 2 TH_UM set value under LL environment	1 - 99	55
AD	HL_LM HEAVY2 CL LL	Correction value for heavy paper 2 TH_LM set value under LL environment	1 - 99	55
AE	HL_US HEAVY2 CL LL	Correction value for heavy paper 2 TH_US set value under LL environment	1 - 99	55
AF	HL_UM WARMUP_120L LL	Correction value for TH_UM set value in Warm-Up at 120°C or below under LL environment	1 - 99	55
AG	HL_LM WARMUP_120L LL	Correction value for TH_LM set value in Warm-Up at 120°C or below under LL environment	1 - 99	55
AH	HL_US WARMUP_120L LL	Correction value for TH_US set value in Warm-Up at 120°C or below under LL environment	1 - 99	55
AI	LO_WARMUP_TIME_LL	Correction value for AF-AH applying time (timer from Ready complete) under LL environment	1 - 99	50
AJ	HL_UM WARMUP_120H LL	Correction value for TH_UM set value in Warm-Up at 120°C or above under LL environment	1 - 99	55
AK	HL_LM WARMUP_120H LL	Correction value for TH_LM set value in Warm-Up at 120°C or above under LL environment	1 - 99	55
AL	HL_US WARMUP_120H LL	Correction value for TH_US set value in Warm-Up at 120°C or above under LL environment	1 - 99	55
AM	HI_WU_TIME_LL	Correction value for AJ-AL applying time (timer from Ready complete) under LL environment	1 - 99	50
AN	HI_WU_FM_ON_TMP_LL	Correction value for FM prior rotation start TH_UM in Warm-Up at alpha °C or above under LL environment	1 - 99	40
AO	HI_WU_END_TIME_LL	Correction value for Warm-Up completion time in Warm-Up at alpha °C or above under LL environment	1 - 99	50
AP	HI_WU_JOB_SET_TMP_LL	Correction value for Job Enable TH_UM temperature in at alpha °C or above under LL environment	1 - 99	55
AQ	HI_WARMUP_BORDER_LL	Correction value for the threshold value alpha applying SIM43-1-AN - AP under LL environment	1 - 99	50
AR	LO_WU_JOB_SET_TMP_LL	Correction value for Job Enable TH_UM temperature in at alpha °C or below under LL environment	1 - 99	55
AS	JOBEND_FUMON_TIME_LL	Correction value for the after rotation time when completing a job under LL environment	1 - 99	50
AT	HI_WU_JOB_SET_TMP_LL_BW	Correction value (BW) for Job enable TH_UM temperature when Warm-Up at alpha °C or above under LL environment	1 - 99	55

\* Item WARMUP END TIME LL: 1 Count = 1s Change

Correction value for the other items: 1 count for 1°C change

- \* Item D, F: When B5 size, correction of "-5" is made for item D and item F.
- \* Item G, I: When B5 size, correction of "-5" is made for item G and item I.

**Code descriptions**

TH_UM	Fusing thermistor main (Front surface of paper)	HL_UM	Heater lamp main (Heat roller for front surface of paper)
TH_LM	Fusing thermistor main (Back surface of paper)	HL_LM	Heater lamp main (Heat roller for back surface of paper)
TH_US	Fusing thermistor sub (Front surface of paper)	HL_US	Heater lamp sub (Heat roller for front surface of paper)

**23cpm machine**

	Item/Display	Content	Setting range	Default value
A	HL_UM READY LL	Correction value for TH_UM set value in Ready standby under LL environment	1 - 99	55
B	HL_LM READY LL	Correction value for TH_LM set value in Ready standby under LL environment	1 - 99	55
C	HL_US READY LL	Correction value for TH_US set value in Ready standby under LL environment	1 - 99	55
D	HL_UM PLAIN BW LL	Correction value for Black-White plain paper TH_UM set value under LL environment	1 - 99	55
E	HL_LM PLAIN BW LL	Correction value for Black-White plain paper TH_LM set value under LL environment	1 - 99	55
F	HL_US PLAIN BW LL	Correction value for Black-White plain paper TH_US set value under LL environment	1 - 99	55
G	HL_UM PLAIN CL LL	Correction value for Color plain paper TH_UM set value under LL environment	1 - 99	55
H	HL_LM PLAIN CL LL	Correction value for Color plain paper TH_LM set value under LL environment	1 - 99	55
I	HL_US PLAIN CL LL	Correction value for Color plain paper TH_US set value under LL environment	1 - 99	55
J	WARMUP FUMON HL_US T LL	Correction value for fusing motor pre-rotation start TH_US set value under LL environment	1 - 99	40
K	WARMUP FUMOFF LL	Fusing motor prior rotation completion time under LL environment	1 - 99	50
L	WARMUP END TIME LL	Correction value for warm-up complete time under LL environment	1 - 99	80
M	HL_UM HEAVY LL	Correction value for heavy paper TH_UM set value under LL environment	1 - 99	55
N	HL_LM HEAVY LL	Correction value for heavy paper TH_LM set value under LL environment	1 - 99	55
O	HL_US HEAVY LL	Correction value for heavy paper TH_US set value under LL environment	1 - 99	55
P	HL_UM OHP LL	Correction value for OHP TH_UM set value under LL environment	1 - 99	55
Q	HL_LM OHP LL	Correction value for OHP TH_LM set value under LL environment	1 - 99	55
R	HL_US OHP LL	Correction value for OHP TH_US set value under LL environment	1 - 99	55
S	HL_UM ENVELOPE LL	Correction value for envelope TH_UM set value under LL environment	1 - 99	55
T	HL_LM ENVELOPE LL	Correction value for envelope TH_LM set value under LL environment	1 - 99	55
U	HL_US ENVELOPE LL	Correction value for envelope TH_US set value under LL environment	1 - 99	55
V	HL_UM GLOSS LL	Correction value for glossy paper TH_UM set value under LL environment	1 - 99	55
W	HL_LM GLOSS LL	Correction value for glossy paper TH_LM set value under LL environment	1 - 99	55
X	HL_US GLOSS LL	Correction value for glossy paper TH_US set value under LL environment	1 - 99	55
Y	HL_UM E-STAR LL	Correction value for preheating TH_UM set value under LL environment	1 - 99	55
Z	HL_US E-STAR LL	Correction value for preheating TH_US set value under LL environment	1 - 99	55
AA	HL_UM PRE-JOB LL	Correction value for the set value of TH_UM when restoring from preheating under LL environment	1 - 99	55
AB	HL_LM E-STAR LL	Correction value for preheating TH_LM set value under LL environment	1 - 99	55
AC	HL_UM HEAVY2 CL LL	Correction value for heavy paper 2 TH_UM set value under LL environment	1 - 99	55
AD	HL_LM HEAVY2 CL LL	Correction value for heavy paper 2 TH_LM set value under LL environment	1 - 99	55
AE	HL_US HEAVY2 CL LL	Correction value for heavy paper 2 TH_US set value under LL environment	1 - 99	55
AF	HL_UM WARMUP_120L LL	Correction value for TH_UM set value in Warm-Up at 120°C or below under LL environment	1 - 99	55
AG	HL_LM WARMUP_120L LL	Correction value for TH_LM set value in Warm-Up at 120°C or below under LL environment	1 - 99	55
AH	HL_US WARMUP_120L LL	Correction value for TH_US set value in Warm-Up at 120°C or below under LL environment	1 - 99	55
AI	LO_WARMUP_TIME_LL	Correction value for AF-AH applying time (timer from Ready complete) under LL environment	1 - 99	50
AJ	HL_UM WARMUP_120H LL	Correction value for TH_UM set value in Warm-Up at 120°C or above under LL environment	1 - 99	55
AK	HL_LM WARMUP_120H LL	Correction value for TH_LM set value in Warm-Up at 120°C or above under LL environment	1 - 99	55
AL	HL_US WARMUP_120H LL	Correction value for TH_US set value in Warm-Up at 120°C or above under LL environment	1 - 99	55
AM	HI_WU_TIME_LL	Correction value for AJ-AL applying time (timer from Ready complete) under LL environment	1 - 99	50
AN	HI_WU_FM_ON_TMP_LL	Correction value for FM prior rotation start TH_UM in Warm-Up at alpha °C or above under LL environment	1 - 99	40
AO	HI_WU_END_TIME_LL	Correction value for Warm-Up completion time in Warm-Up at alpha °C or above under LL environment	1 - 99	50
AP	HI_WU_JOB_SET_TMP_LL	Correction value for Job Enable TH_UM temperature in at alpha °C or above under LL environment	1 - 99	55
AQ	HI_WARMUP_BORDER_LL	Correction value for the threshold value alpha applying SIM43-1-AN - AP under LL environment	1 - 99	50
AR	LO_WU_JOB_SET_TMP_LL	Correction value for Job Enable TH_UM temperature in at alpha °C or below under LL environment	1 - 99	55
AS	JOBEND_FUMON_TIME_LL	Correction value for the after rotation time when completing a job under LL environment	1 - 99	50
AT	HI_WU_JOB_SET_TMP_LL_BW	Correction value (BW) for Job enable TH_UM temperature when Warm-Up at alpha °C or above under LL environment	1 - 99	55

- \* Item WARMUP END TIME LL: 1 Count = 1s Change  
Correction value for the other items: 1 count for 1°C change
- \* Item D, F: When B5 size, correction of "-5" is made for item D and item F.
- \* Item G, I: When B5 size, correction of "-5" is made for item G and item I.

**Code descriptions**

TH_UM	Fusing thermistor main (Front surface of paper)	HL_UM	Heater lamp main (Heat roller for front surface of paper)
TH_LM	Fusing thermistor main (Back surface of paper)	HL_LM	Heater lamp main (Heat roller for back surface of paper)
TH_US	Fusing thermistor sub (Front surface of paper)	HL_US	Heater lamp sub (Heat roller for front surface of paper)

26cpm/31cpm machine

Item/Display		Content	Setting range	Default value
A	HL_UM READY LL	Correction value for TH_UM set value in Ready standby under LL environment	1 - 99	55
B	HL_LM READY LL	Correction value for TH_LM set value in Ready standby under LL environment	1 - 99	55
C	HL_US READY LL	Correction value for TH_US set value in Ready standby under LL environment	1 - 99	55
D	HL_UM PLAIN BW LL	Correction value for Black-White plain paper TH_UM set value under LL environment	1 - 99	55
E	HL_LM PLAIN BW LL	Correction value for Black-White plain paper TH_LM set value under LL environment	1 - 99	55
F	HL_US PLAIN BW LL	Correction value for Black-White plain paper TH_US set value under LL environment	1 - 99	55
G	HL_UM PLAIN CL LL	Correction value for Color plain paper TH_UM set value under LL environment	1 - 99	55
H	HL_LM PLAIN CL LL	Correction value for Color plain paper TH_LM set value under LL environment	1 - 99	55
I	HL_US PLAIN CL LL	Correction value for Color plain paper TH_US set value under LL environment	1 - 99	55
J	WARMUP FUMON HL_US T LL	Correction value for fusing motor pre-rotation start TH_US set value under LL environment	1 - 99	40
K	WARMUP FUMOFF LL	Fusing motor prior rotation completion time under LL environment	1 - 99	50
L	WARMUP END TIME LL	Correction value for warm-up complete time under LL environment	1 - 99	80
M	HL_UM HEAVY LL	Correction value for heavy paper TH_UM set value under LL environment	1 - 99	55
N	HL_LM HEAVY LL	Correction value for heavy paper TH_LM set value under LL environment	1 - 99	55
O	HL_US HEAVY LL	Correction value for heavy paper TH_US set value under LL environment	1 - 99	55
P	HL_UM OHP LL	Correction value for OHP TH_UM set value under LL environment	1 - 99	55
Q	HL_LM OHP LL	Correction value for OHP TH_LM set value under LL environment	1 - 99	55
R	HL_US OHP LL	Correction value for OHP TH_US set value under LL environment	1 - 99	55
S	HL_UM ENVELOPE LL	Correction value for envelope TH_UM set value under LL environment	1 - 99	55
T	HL_LM ENVELOPE LL	Correction value for envelope TH_LM set value under LL environment	1 - 99	55
U	HL_US ENVELOPE LL	Correction value for envelope TH_US set value under LL environment	1 - 99	55
V	HL_UM GLOSS LL	Correction value for glossy paper TH_UM set value under LL environment	1 - 99	55
W	HL_LM GLOSS LL	Correction value for glossy paper TH_LM set value under LL environment	1 - 99	55
X	HL_US GLOSS LL	Correction value for glossy paper TH_US set value under LL environment	1 - 99	55
Y	HL_UM E-STAR LL	Correction value for preheating TH_UM set value under LL environment	1 - 99	55
Z	HL_US E-STAR LL	Correction value for preheating TH_US set value under LL environment	1 - 99	55
AA	HL_UM PRE-JOB LL	Correction value for the set value of TH_UM when restoring from preheating under LL environment	1 - 99	55
AB	HL_LM E-STAR LL	Correction value for preheating TH_LM set value under LL environment	1 - 99	55
AC	HL_UM HEAVY2 CL LL	Correction value for heavy paper 2 TH_UM set value under LL environment	1 - 99	55
AD	HL_LM HEAVY2 CL LL	Correction value for heavy paper 2 TH_LM set value under LL environment	1 - 99	55
AE	HL_US HEAVY2 CL LL	Correction value for heavy paper 2 TH_US set value under LL environment	1 - 99	55
AF	HL_UM WARMUP_120L LL	Correction value for TH_UM set value in Warm-Up at 120°C or below under LL environment	1 - 99	55
AG	HL_LM WARMUP_120L LL	Correction value for TH_LM set value in Warm-Up at 120°C or below under LL environment	1 - 99	55
AH	HL_US WARMUP_120L LL	Correction value for TH_US set value in Warm-Up at 120°C or below under LL environment	1 - 99	55
AI	LO_WARMUP_TIME_LL	Correction value for AF-AH applying time (timer from Ready complete) under LL environment	1 - 99	50
AJ	HL_UM WARMUP_120H LL	Correction value for TH_UM set value in Warm-Up at 120°C or above under LL environment	1 - 99	55
AK	HL_LM WARMUP_120H LL	Correction value for TH_LM set value in Warm-Up at 120°C or above under LL environment	1 - 99	55
AL	HL_US WARMUP_120H LL	Correction value for TH_US set value in Warm-Up at 120°C or above under LL environment	1 - 99	55
AM	HI_WU_TIME_LL	Correction value for AJ-AL applying time (timer from Ready complete) under LL environment	1 - 99	50
AN	HI_WU_FM_ON_TMP_LL	Correction value for FM prior rotation start TH_UM in Warm-Up at alpha °C or above under LL environment	1 - 99	40
AO	HI_WU_END_TIME_LL	Correction value for Warm-Up completion time in Warm-Up at alpha °C or above under LL environment	1 - 99	50
AP	HI_WU_JOB_SET_TMP_LL	Correction value for Job Enable TH_UM temperature in at alpha °C or above under LL environment	1 - 99	55
AQ	HI_WARMUP_BORDER_LL	Correction value for the threshold value alpha applying SIM43-1-AN - AP under LL environment	1 - 99	50
AR	LO_WU_JOB_SET_TMP_LL	Correction value for Job Enable TH_UM temperature in at alpha °C or below under LL environment	1 - 99	55
AS	JOBEND_FUMON_TIME_LL	Correction value for the after rotation time when completing a job under LL environment	1 - 99	50
AT	HI_WU_JOB_SET_TMP_LL_BW	Correction value (BW) for Job enable TH_UM temperature when Warm-Up at alpha °C or above under LL environment	1 - 99	55

\* Item WARMUP END TIME LL: 1 Count = 1s Change

Correction value for the other items: 1 count for 1°C change

\* Item D, F: When B5 size, correction of "-5" is made for item D and item F.

\* Item G, I: When B5 size, correction of "-5" is made for item G and item I.

**Code descriptions**

TH_UM	Fusing thermistor main (Front surface of paper)	HL_UM	Heater lamp main (Heat roller for front surface of paper)
TH_LM	Fusing thermistor main (Back surface of paper)	HL_LM	Heater lamp main (Heat roller for back surface of paper)
TH_US	Fusing thermistor sub (Front surface of paper)	HL_US	Heater lamp sub (Heat roller for front surface of paper)

36cpm machine

	Item/Display	Content	Setting range	Default value
A	HL_UM READY LL	Correction value for TH_UM set value in Ready standby under LL environment	1 - 99	55
B	HL_LM READY LL	Correction value for TH_LM set value in Ready standby under LL environment	1 - 99	55
C	HL_US READY LL	Correction value for TH_US set value in Ready standby under LL environment	1 - 99	55
D	HL_UM PLAIN BW LL	Correction value for Black-White plain paper TH_UM set value under LL environment	1 - 99	55
E	HL_LM PLAIN BW LL	Correction value for Black-White plain paper TH_LM set value under LL environment	1 - 99	55
F	HL_US PLAIN BW LL	Correction value for Black-White plain paper TH_US set value under LL environment	1 - 99	55
G	HL_UM PLAIN CL LL	Correction value for Color plain paper TH_UM set value under LL environment	1 - 99	55
H	HL_LM PLAIN CL LL	Correction value for Color plain paper TH_LM set value under LL environment	1 - 99	55
I	HL_US PLAIN CL LL	Correction value for Color plain paper TH_US set value under LL environment	1 - 99	55
J	WARMUP FUMON HL_US T LL	Correction value for fusing motor pre-rotation start TH_US set value under LL environment	1 - 99	40
K	WARMUP FUMOFF LL	Fusing motor prior rotation completion time under LL environment	1 - 99	50
L	WARMUP END TIME LL	Correction value for warm-up complete time under LL environment	1 - 99	80
M	HL_UM HEAVY LL	Correction value for heavy paper TH_UM set value under LL environment	1 - 99	55
N	HL_LM HEAVY LL	Correction value for heavy paper TH_LM set value under LL environment	1 - 99	55
O	HL_US HEAVY LL	Correction value for heavy paper TH_US set value under LL environment	1 - 99	55
P	HL_UM OHP LL	Correction value for OHP TH_UM set value under LL environment	1 - 99	55
Q	HL_LM OHP LL	Correction value for OHP TH_LM set value under LL environment	1 - 99	55
R	HL_US OHP LL	Correction value for OHP TH_US set value under LL environment	1 - 99	55
S	HL_UM ENVELOPE LL	Correction value for envelope TH_UM set value under LL environment	1 - 99	55
T	HL_LM ENVELOPE LL	Correction value for envelope TH_LM set value under LL environment	1 - 99	55
U	HL_US ENVELOPE LL	Correction value for envelope TH_US set value under LL environment	1 - 99	55
V	HL_UM GLOSS LL	Correction value for glossy paper TH_UM set value under LL environment	1 - 99	55
W	HL_LM GLOSS LL	Correction value for glossy paper TH_LM set value under LL environment	1 - 99	55
X	HL_US GLOSS LL	Correction value for glossy paper TH_US set value under LL environment	1 - 99	55
Y	HL_UM E-STAR LL	Correction value for preheating TH_UM set value under LL environment	1 - 99	55
Z	HL_US E-STAR LL	Correction value for preheating TH_US set value under LL environment	1 - 99	55
AA	HL_UM PRE-JOB LL	Correction value for the set value of TH_UM when restoring from preheating under LL environment	1 - 99	55
AB	HL_LM E-STAR LL	Correction value for preheating TH_LM set value under LL environment	1 - 99	55
AC	HL_UM HEAVY2 CL LL	Correction value for heavy paper 2 TH_UM set value under LL environment	1 - 99	55
AD	HL_LM HEAVY2 CL LL	Correction value for heavy paper 2 TH_LM set value under LL environment	1 - 99	55
AE	HL_US HEAVY2 CL LL	Correction value for heavy paper 2 TH_US set value under LL environment	1 - 99	55
AF	HL_UM WARMUP_120L LL	Correction value for TH_UM set value in Warm-Up at 120°C or below under LL environment	1 - 99	55
AG	HL_LM WARMUP_120L LL	Correction value for TH_LM set value in Warm-Up at 120°C or below under LL environment	1 - 99	55
AH	HL_US WARMUP_120L LL	Correction value for TH_US set value in Warm-Up at 120°C or below under LL environment	1 - 99	55
AI	LO_WARMUP_TIME_LL	Correction value for AF-AH applying time (timer from Ready complete) under LL environment	1 - 99	50
AJ	HL_UM WARMUP_120H LL	Correction value for TH_UM set value in Warm-Up at 120°C or above under LL environment	1 - 99	55
AK	HL_LM WARMUP_120H LL	Correction value for TH_LM set value in Warm-Up at 120°C or above under LL environment	1 - 99	55
AL	HL_US WARMUP_120H LL	Correction value for TH_US set value in Warm-Up at 120°C or above under LL environment	1 - 99	55
AM	HI_WU_TIME_LL	Correction value for AJ-AL applying time (timer from Ready complete) under LL environment	1 - 99	50
AN	HI_WU_FM_ON_TMP_LL	Correction value for FM prior rotation start TH_UM in Warm-Up at alpha °C or above under LL environment	1 - 99	40
AO	HI_WU_END_TIME_LL	Correction value for Warm-Up completion time in Warm-Up at alpha °C or above under LL environment	1 - 99	50
AP	HI_WU_JOB_SET_TMP_LL	Correction value for Job Enable TH_UM temperature in at alpha °C or above under LL environment	1 - 99	55
AQ	HI_WARMUP_BORDER_LL	Correction value for the threshold value alpha applying SIM43-1-AN - AP under LL environment	1 - 99	50
AR	LO_WU_JOB_SET_TMP_LL	Correction value for Job Enable TH_UM temperature in at alpha °C or below under LL environment	1 - 99	55
AS	JOBEND_FUMON_TIME_LL	Correction value for the after rotation time when completing a job under LL environment	1 - 99	50
AT	HI_WU_JOB_SET_TMP_LL_BW	Correction value (BW) for Job enable TH_UM temperature when Warm-Up at alpha °C or above under LL environment	1 - 99	55

- \* Item WARMUP END TIME LL: 1 Count = 1s Change  
Correction value for the other items: 1 count for 1°C change
- \* Item D, F: When B5 size, correction of "-5" is made for item D and item F.
- \* Item G, I: When B5 size, correction of "-5" is made for item G and item I.

Code descriptions

TH_UM	Fusing thermistor main (Front surface of paper)	HL_UM	Heater lamp main (Heat roller for front surface of paper)
TH_LM	Fusing thermistor main (Back surface of paper)	HL_LM	Heater lamp main (Heat roller for back surface of paper)
TH_US	Fusing thermistor sub (Front surface of paper)	HL_US	Heater lamp sub (Heat roller for front surface of paper)

<b>Purpose</b>	Adjustment/Setup
<b>Function (Purpose)</b>	Used to set the environment correction under high temperature and high humidity (H/H) for the fusing temperature setting (SIM 43-1) in each paper mode.
<b>Section</b>	

**Operation/Procedure**

- 1) Select an item to be set with scroll keys.
- 2) Enter the set value with 10-key.
- 3) Press [OK] key.

The set value in step 2 is saved.

Correction value: -49 - +49, Input value: Actually inputted value (1 - 99)

Correction value	-49	-25	-5	0	5	25	49
Input value	1	25	45	50	55	75	99

**18cpm/20cpm machine**

Item/Display		Content	Setting range	Default value
A	HL_UM READY HH	Correction value for TH_UM set value in Ready standby under HH environment	1 - 99	50
B	HL_LM READY HH	Correction value for TH_LM set value in Ready standby under HH environment	1 - 99	50
C	HL_US READY HH	Correction value for TH_US set value in Ready standby under HH environment	1 - 99	50
D	HL_UM PLAIN BW HH	Correction value for Black-White plain paper TH_UM set value under HH environment	1 - 99	50
E	HL_LM PLAIN BW HH	Correction value for Black-White plain paper TH_LM set value under HH environment	1 - 99	50
F	HL_US PLAIN BW HH	Correction value for Black-White plain paper TH_US set value under HH environment	1 - 99	50
G	HL_UM PLAIN CL HH	Correction value for Color plain paper TH_UM set value under HH environment	1 - 99	50
H	HL_LM PLAIN CL HH	Correction value for Color plain paper TH_LM set value under HH environment	1 - 99	50
I	HL_US PLAIN CL HH	Correction value for Color plain paper TH_US set value under HH environment	1 - 99	50
J	WARMUP FUMON HL_US T HH	Correction value for fusing motor pre-rotation start TH_US set value under HH environment	1 - 99	50
K	WARMUP FUMOFF HH	Fusing motor prior rotation completion time under HH environment	1 - 99	50
L	WARMUP END TIME HH	Correction value for warm-up complete time under HH environment	1 - 99	50
M	HL_UM HEAVY HH	Correction value for heavy paper TH_UM set value under HH environment	1 - 99	50
N	HL_LM HEAVY HH	Correction value for heavy paper TH_LM set value under HH environment	1 - 99	50
O	HL_US HEAVY HH	Correction value for heavy paper TH_US set value under HH environment	1 - 99	50
P	HL_UM OHP HH	Correction value for OHP TH_UM set value under HH environment	1 - 99	50
Q	HL_LM OHP HH	Correction value for OHP TH_LM set value under HH environment	1 - 99	50
R	HL_US OHP HH	Correction value for OHP TH_US set value under HH environment	1 - 99	50
S	HL_UM ENVELOPE HH	Correction value for envelope TH_UM set value under HH environment	1 - 99	50
T	HL_LM ENVELOPE HH	Correction value for envelope TH_LM set value under HH environment	1 - 99	50
U	HL_US ENVELOPE HH	Correction value for envelope TH_US set value under HH environment	1 - 99	50
V	HL_UM GLOSS HH	Correction value for glossy paper TH_UM set value under HH environment	1 - 99	50
W	HL_LM GLOSS HH	Correction value for glossy paper TH_LM set value under HH environment	1 - 99	50
X	HL_US GLOSS HH	Correction value for glossy paper TH_US set value under HH environment	1 - 99	50
Y	HL_UM E-STAR HH	Correction value for preheating TH_UM set value under HH environment	1 - 99	50
Z	HL_US E-STAR HH	Correction value for preheating TH_US set value under HH environment	1 - 99	50
AA	HL_UM PRE-JOB HH	Correction value for the set value of TH_UM when restoring from preheating under HH environment	1 - 99	50
AB	HL_LM E-STAR HH	Correction value for preheating TH_LM set value under HH environment	1 - 99	50
AC	HL_UM HEAVY2 CL HH	Correction value for heavy paper 2 TH_UM set value under HH environment	1 - 99	50
AD	HL_LM HEAVY2 CL HH	Correction value for heavy paper 2 TH_LM set value under HH environment	1 - 99	50
AE	HL_US HEAVY2 CL HH	Correction value for heavy paper 2 TH_US set value under HH environment	1 - 99	50
AF	HL_UM WARMUP_120L HH	Correction value for TH_UM set value in Warm-Up at 120°C or below under HH environment	1 - 99	50
AG	HL_LM WARMUP_120L HH	Correction value for TH_LM set value in Warm-Up at 120°C or below under HH environment	1 - 99	50
AH	HL_US WARMUP_120L HH	Correction value for TH_US set value in Warm-Up at 120°C or below under HH environment	1 - 99	50
AI	LO_WARMUP_TIME_HH	Correction value for AF-AH applying time (timer from Ready complete) under HH environment	1 - 99	50
AJ	HL_UM WARMUP_120H HH	Correction value for TH_UM set value in Warm-Up at 120°C or above under HH environment	1 - 99	50
AK	HL_LM WARMUP_120H HH	Correction value for TH_LM set value in Warm-Up at 120°C or above under HH environment	1 - 99	50
AL	HL_US WARMUP_120H HH	Correction value for TH_US set value in Warm-Up at 120°C or above under HH environment	1 - 99	50
AM	HI_WU_TIME_HH	Correction value for AJ-AL applying time (timer from Ready complete) under HH environment	1 - 99	50
AN	HI_WU_FM_ON_TMP_HH	Correction value for FM prior rotation start TH_US in Warm-Up at alpha °C or above under HH environment	1 - 99	50
AO	HI_WU_END_TIME_HH	Correction value for Warm-Up completion time in Warm-Up at alpha °C or above under HH environment	1 - 99	50
AP	HI_WU_JOB_SET_TMP_HH	Correction value for Job Enable TH_UM temperature in Warm-Up at alpha °C or above under HH environment	1 - 99	50
AQ	HI_WARMUP_BORDER_HH	Correction value for the threshold value alpha applying SIM43-1-AN - AP under HH environment	1 - 99	50
AR	LO_WU_JOB_SET_TMP_HH	Correction value for Job Enable TH_UM temperature in Warm-Up at alpha °C or below under HH environment	1 - 99	50
AS	JOBEND_FUMON_TIME LL	Correction value for the after rotation time when completing a job under HH environment	1 - 99	50
AT	HI_WU_JOB_SET_TMP_HH_B W	Correction value (BW) for Job enable TH_UM temperature when Warm-Up at alpha °C or above under HH environment	1 - 99	50

\* Item WARMUP END TIME HH: 1 Count = 1s Change  
Correction value for the other items: 1 count for 1°C change

**Code descriptions**

TH_UM	Fusing thermistor main (Front surface of paper)	HL_UM	Heater lamp main (Heat roller for front surface of paper)
TH_LM	Fusing thermistor main (Back surface of paper)	HL_LM	Heater lamp main (Heat roller for back surface of paper)
TH_US	Fusing thermistor sub (Front surface of paper)	HL_US	Heater lamp sub (Heat roller for front surface of paper)

**23cpm machine**

Item/Display		Content	Setting range	Default value
A	HL_UM READY HH	Correction value for TH_UM set value in Ready standby under HH environment	1 - 99	50
B	HL_LM READY HH	Correction value for TH_LM set value in Ready standby under HH environment	1 - 99	50
C	HL_US READY HH	Correction value for TH_US set value in Ready standby under HH environment	1 - 99	50
D	HL_UM PLAIN BW HH	Correction value for Black-White plain paper TH_UM set value under HH environment	1 - 99	50
E	HL_LM PLAIN BW HH	Correction value for Black-White plain paper TH_LM set value under HH environment	1 - 99	50
F	HL_US PLAIN BW HH	Correction value for Black-White plain paper TH_US set value under HH environment	1 - 99	50
G	HL_UM PLAIN CL HH	Correction value for Color plain paper TH_UM set value under HH environment	1 - 99	50
H	HL_LM PLAIN CL HH	Correction value for Color plain paper TH_LM set value under HH environment	1 - 99	50
I	HL_US PLAIN CL HH	Correction value for Color plain paper TH_US set value under HH environment	1 - 99	50
J	WARMUP FUMON HL_US T HH	Correction value for fusing motor pre-rotation start TH_US set value under HH environment	1 - 99	50
K	WARMUP FUMOFF HH	Fusing motor prior rotation completion time under HH environment	1 - 99	50
L	WARMUP END TIME HH	Correction value for warm-up complete time under HH environment	1 - 99	50
M	HL_UM HEAVY HH	Correction value for heavy paper TH_UM set value under HH environment	1 - 99	50
N	HL_LM HEAVY HH	Correction value for heavy paper TH_LM set value under HH environment	1 - 99	50
O	HL_US HEAVY HH	Correction value for heavy paper TH_US set value under HH environment	1 - 99	50
P	HL_UM OHP HH	Correction value for OHP TH_UM set value under HH environment	1 - 99	50
Q	HL_LM OHP HH	Correction value for OHP TH_LM set value under HH environment	1 - 99	50
R	HL_US OHP HH	Correction value for OHP TH_US set value under HH environment	1 - 99	50
S	HL_UM ENVELOPE HH	Correction value for envelope TH_UM set value under HH environment	1 - 99	50
T	HL_LM ENVELOPE HH	Correction value for envelope TH_LM set value under HH environment	1 - 99	50
U	HL_US ENVELOPE HH	Correction value for envelope TH_US set value under HH environment	1 - 99	50
V	HL_UM GLOSS HH	Correction value for glossy paper TH_UM set value under HH environment	1 - 99	50
W	HL_LM GLOSS HH	Correction value for glossy paper TH_LM set value under HH environment	1 - 99	50
X	HL_US GLOSS HH	Correction value for glossy paper TH_US set value under HH environment	1 - 99	50
Y	HL_UM E-STAR HH	Correction value for preheating TH_UM set value under HH environment	1 - 99	50
Z	HL_US E-STAR HH	Correction value for preheating TH_US set value under HH environment	1 - 99	50
AA	HL_UM PRE-JOB HH	Correction value for the set value of TH_UM when restoring from preheating under HH environment	1 - 99	50
AB	HL_LM E-STAR HH	Correction value for preheating TH_LM set value under HH environment	1 - 99	50
AC	HL_UM HEAVY2 CL HH	Correction value for heavy paper 2 TH_UM set value under HH environment	1 - 99	50
AD	HL_LM HEAVY2 CL HH	Correction value for heavy paper 2 TH_LM set value under HH environment	1 - 99	50
AE	HL_US HEAVY2 CL HH	Correction value for heavy paper 2 TH_US set value under HH environment	1 - 99	50
AF	HL_UM WARMUP_120L HH	Correction value for TH_UM set value in Warm-Up at 120°C or below under HH environment	1 - 99	50
AG	HL_LM WARMUP_120L HH	Correction value for TH_LM set value in Warm-Up at 120°C or below under HH environment	1 - 99	50
AH	HL_US WARMUP_120L HH	Correction value for TH_US set value in Warm-Up at 120°C or below under HH environment	1 - 99	50
AI	LO_WARMUP_TIME_HH	Correction value for AF-AH applying time (timer from Ready complete) under HH environment	1 - 99	50
AJ	HL_UM WARMUP_120H HH	Correction value for TH_UM set value in Warm-Up at 120°C or above under HH environment	1 - 99	50
AK	HL_LM WARMUP_120H HH	Correction value for TH_LM set value in Warm-Up at 120°C or above under HH environment	1 - 99	50
AL	HL_US WARMUP_120H HH	Correction value for TH_US set value in Warm-Up at 120°C or above under HH environment	1 - 99	50
AM	HI_WU_TIME_HH	Correction value for AJ-AL applying time (timer from Ready complete) under HH environment	1 - 99	50
AN	HI_WU_FM_ON_TMP_HH	Correction value for FM prior rotation start TH_US in Warm-Up at alpha °C or above under HH environment	1 - 99	50
AO	HI_WU_END_TIME_HH	Correction value for Warm-Up completion time in Warm-Up at alpha °C or above under HH environment	1 - 99	50
AP	HI_WU_JOB_SET_TMP_HH	Correction value for Job Enable TH_UM temperature in Warm-Up at alpha °C or above under HH environment	1 - 99	50
AQ	HI_WARMUP_BORDER_HH	Correction value for the threshold value alpha applying SIM43-1-AN - AP under HH environment	1 - 99	50
AR	LO_WU_JOB_SET_TMP_HH	Correction value for Job Enable TH_UM temperature in Warm-Up at alpha °C or below under HH environment	1 - 99	50
AS	JOBEND_FUMON_TIME LL	Correction value for the after rotation time when completing a job under HH environment	1 - 99	50
AT	HI_WU_JOB_SET_TMP_HH_BW	Correction value (BW) for Job enable TH_UM temperature when Warm-Up at alpha °C or above under HH environment	1 - 99	50

\* Item WARMUP END TIME HH: 1 Count = 1s Change  
Correction value for the other items: 1 count for 1°C change

**Code descriptions**

TH_UM	Fusing thermistor main (Front surface of paper)	HL_UM	Heater lamp main (Heat roller for front surface of paper)
TH_LM	Fusing thermistor main (Back surface of paper)	HL_LM	Heater lamp main (Heat roller for back surface of paper)
TH_US	Fusing thermistor sub (Front surface of paper)	HL_US	Heater lamp sub (Heat roller for front surface of paper)

26cpm/31cpm machine

Item/Display		Content	Setting range	Default value		
				Group A	Group B	Group C
A	HL_UM READY HH	Correction value for TH_UM set value in Ready standby under HH environment	1 - 99	40	45	50
B	HL_LM READY HH	Correction value for TH_LM set value in Ready standby under HH environment	1 - 99	40	45	50
C	HL_US READY HH	Correction value for TH_US set value in Ready standby under HH environment	1 - 99	40	45	50
D	HL_UM PLAIN BW HH	Correction value for Black-White plain paper TH_UM set value under HH environment	1 - 99	40	45	50
E	HL_LM PLAIN BW HH	Correction value for Black-White plain paper TH_LM set value under HH environment	1 - 99	40	45	50
F	HL_US PLAIN BW HH	Correction value for Black-White plain paper TH_US set value under HH environment	1 - 99	40	45	50
G	HL_UM PLAIN CL HH	Correction value for Color plain paper TH_UM set value under HH environment	1 - 99	40	45	50
H	HL_LM PLAIN CL HH	Correction value for Color plain paper TH_LM set value under HH environment	1 - 99	40	45	50
I	HL_US PLAIN CL HH	Correction value for Color plain paper TH_US set value under HH environment	1 - 99	40	45	50
J	WARMUP FUMON HL_US T HH	Correction value for fusing motor pre-rotation start TH_US set value under HH environment	1 - 99	50	50	50
K	WARMUP FUMOFF HH	Fusing motor prior rotation completion time under HH environment	1 - 99	50	50	50
L	WARMUP END TIME HH	Correction value for warm-up complete time under HH environment	1 - 99	50	50	50
M	HL_UM HEAVY HH	Correction value for heavy paper TH_UM set value under HH environment	1 - 99	50	50	50
N	HL_LM HEAVY HH	Correction value for heavy paper TH_LM set value under HH environment	1 - 99	50	50	50
O	HL_US HEAVY HH	Correction value for heavy paper TH_US set value under HH environment	1 - 99	50	50	50
P	HL_UM OHP HH	Correction value for OHP TH_UM set value under HH environment	1 - 99	50	50	50
Q	HL_LM OHP HH	Correction value for OHP TH_LM set value under HH environment	1 - 99	50	50	50
R	HL_US OHP HH	Correction value for OHP TH_US set value under HH environment	1 - 99	50	50	50
S	HL_UM ENVELOPE HH	Correction value for envelope TH_UM set value under HH environment	1 - 99	50	50	50
T	HL_LM ENVELOPE HH	Correction value for envelope TH_LM set value under HH environment	1 - 99	50	50	50
U	HL_US ENVELOPE HH	Correction value for envelope TH_US set value under HH environment	1 - 99	50	50	50
V	HL_UM GLOSS HH	Correction value for glossy paper TH_UM set value under HH environment	1 - 99	50	50	50
W	HL_LM GLOSS HH	Correction value for glossy paper TH_LM set value under HH environment	1 - 99	50	50	50
X	HL_US GLOSS HH	Correction value for glossy paper TH_US set value under HH environment	1 - 99	50	50	50
Y	HL_UM E-STAR HH	Correction value for preheating TH_UM set value under HH environment	1 - 99	40	45	50
Z	HL_US E-STAR HH	Correction value for preheating TH_US set value under HH environment	1 - 99	40	45	50
AA	HL_UM PRE-JOB HH	Correction value for the set value of TH_UM when restoring from preheating under HH environment	1 - 99	40	45	50
AB	HL_LM E-STAR HH	Correction value for preheating TH_LM set value under HH environment	1 - 99	40	45	50
AC	HL_UM HEAVY2 CL HH	Correction value for heavy paper 2 TH_UM set value under HH environment	1 - 99	50	50	50
AD	HL_LM HEAVY2 CL HH	Correction value for heavy paper 2 TH_LM set value under HH environment	1 - 99	50	50	50
AE	HL_US HEAVY2 CL HH	Correction value for heavy paper 2 TH_US set value under HH environment	1 - 99	50	50	50
AF	HL_UM WARMUP_120L HH	Correction value for TH_UM set value in Warm-Up at 120°C or below under HH environment	1 - 99	40	45	50
AG	HL_LM WARMUP_120L HH	Correction value for TH_LM set value in Warm-Up at 120°C or below under HH environment	1 - 99	40	45	50
AH	HL_US WARMUP_120L HH	Correction value for TH_US set value in Warm-Up at 120°C or below under HH environment	1 - 99	40	45	50
AI	LO_WARMUP_TIME_HH	Correction value for AF-AH applying time (timer from Ready complete) under HH environment	1 - 99	50	50	50
AJ	HL_UM WARMUP_120H HH	Correction value for TH_UM set value in Warm-Up at 120°C or above under HH environment	1 - 99	40	45	50
AK	HL_LM WARMUP_120H HH	Correction value for TH_LM set value in Warm-Up at 120°C or above under HH environment	1 - 99	40	45	50
AL	HL_US WARMUP_120H HH	Correction value for TH_US set value in Warm-Up at 120°C or above under HH environment	1 - 99	40	45	50
AM	HI_WU_TIME_HH	Correction value for AJ-AL applying time (timer from Ready complete) under HH environment	1 - 99	50	50	50
AN	HI_WU_FM_ON_TMP_HH	Correction value for FM prior rotation start TH_US in Warm-Up at alpha °C or above under HH environment	1 - 99	50	50	50
AO	HI_WU_END_TIME_HH	Correction value for Warm-Up completion time in Warm-Up at alpha °C or above under HH environment	1 - 99	50	50	50
AP	HI_WU_JOB_SET_TMP_HH	Correction value for Job Enable TH_UM temperature in Warm-Up at alpha °C or above under HH environment	1 - 99	40	45	50
AQ	HI_WARMUP_BORDER_HH	Correction value for the threshold value alpha applying SIM43-1-AN - AP under HH environment	1 - 99	50	50	50
AR	LO_WU_JOB_SET_TMP_HH	Correction value for Job Enable TH_UM temperature in Warm-Up at alpha °C or below under HH environment	1 - 99	40	45	50
AS	JOBEND_FUMON_TIME LL	Correction value for the after rotation time when completing a job under HH environment	1 - 99	50	50	50

Item/Display	Content	Setting range	Default value		
			Group A	Group B	Group C
AT HI_WU_JOB_SET_TMP_HH_B W	Correction value (BW) for Job enable TH_UM temperature when Warm-Up at alpha °C or above under HH environment	1 - 99	40	45	50

\* Item WARMUP END TIME HH: 1 Count = 1s Change  
Correction value for the other items: 1 count for 1°C change

#### Code descriptions

TH_UM	Fusing thermistor main (Front surface of paper)	HL_UM	Heater lamp main (Heat roller for front surface of paper)
TH_LM	Fusing thermistor main (Back surface of paper)	HL_LM	Heater lamp main (Heat roller for back surface of paper)
TH_US	Fusing thermistor sub (Front surface of paper)	HL_US	Heater lamp sub (Heat roller for front surface of paper)

#### List of destination groups

Group	Destination				
Group A	JAPAN	-	-	-	-
Group B	U. S. A	CANADA	INCH	-	-
Group C	EUROPE	U. K	AUS.	AB_B	CHINA

#### 36cpm machine

Item/Display	Content	Setting range	Default value
A	HL_UM READY HH	Correction value for TH_UM set value in Ready standby under HH environment	1 - 99 45
B	HL_LM READY HH	Correction value for TH_LM set value in Ready standby under HH environment	1 - 99 45
C	HL_US READY HH	Correction value for TH_US set value in Ready standby under HH environment	1 - 99 45
D	HL_UM PLAIN BW HH	Correction value for Black-White plain paper TH_UM set value under HH environment	1 - 99 45
E	HL_LM PLAIN BW HH	Correction value for Black-White plain paper TH_LM set value under HH environment	1 - 99 45
F	HL_US PLAIN BW HH	Correction value for Black-White plain paper TH_US set value under HH environment	1 - 99 45
G	HL_UM PLAIN CL HH	Correction value for Color plain paper TH_UM set value under HH environment	1 - 99 45
H	HL_LM PLAIN CL HH	Correction value for Color plain paper TH_LM set value under HH environment	1 - 99 45
I	HL_US PLAIN CL HH	Correction value for Color plain paper TH_US set value under HH environment	1 - 99 45
J	WARMUP FUMON HL_US T HH	Correction value for fusing motor pre-rotation start TH_US set value under HH environment	1 - 99 50
K	WARMUP FUMOFF HH	Fusing motor prior rotation completion time under HH environment	1 - 99 50
L	WARMUP END TIME HH	Correction value for warm-up complete time under HH environment	1 - 99 50
M	HL_UM HEAVY HH	Correction value for heavy paper TH_UM set value under HH environment	1 - 99 50
N	HL_LM HEAVY HH	Correction value for heavy paper TH_LM set value under HH environment	1 - 99 50
O	HL_US HEAVY HH	Correction value for heavy paper TH_US set value under HH environment	1 - 99 50
P	HL_UM OHP HH	Correction value for OHP TH_UM set value under HH environment	1 - 99 50
Q	HL_LM OHP HH	Correction value for OHP TH_LM set value under HH environment	1 - 99 50
R	HL_US OHP HH	Correction value for OHP TH_US set value under HH environment	1 - 99 50
S	HL_UM ENVELOPE HH	Correction value for envelope TH_UM set value under HH environment	1 - 99 50
T	HL_LM ENVELOPE HH	Correction value for envelope TH_LM set value under HH environment	1 - 99 50
U	HL_US ENVELOPE HH	Correction value for envelope TH_US set value under HH environment	1 - 99 50
V	HL_UM GLOSS HH	Correction value for glossy paper TH_UM set value under HH environment	1 - 99 50
W	HL_LM GLOSS HH	Correction value for glossy paper TH_LM set value under HH environment	1 - 99 50
X	HL_US GLOSS HH	Correction value for glossy paper TH_US set value under HH environment	1 - 99 50
Y	HL_UM E-STAR HH	Correction value for preheating TH_UM set value under HH environment	1 - 99 45
Z	HL_US E-STAR HH	Correction value for preheating TH_US set value under HH environment	1 - 99 45
AA	HL_UM PRE-JOB HH	Correction value for the set value of TH_UM when restoring from preheating under HH environment	1 - 99 45
AB	HL_LM E-STAR HH	Correction value for preheating TH_LM set value under HH environment	1 - 99 45
AC	HL_UM HEAVY2 CL HH	Correction value for heavy paper 2 TH_UM set value under HH environment	1 - 99 50
AD	HL_LM HEAVY2 CL HH	Correction value for heavy paper 2 TH_LM set value under HH environment	1 - 99 50
AE	HL_US HEAVY2 CL HH	Correction value for heavy paper 2 TH_US set value under HH environment	1 - 99 50
AF	HL_UM WARMUP_120L HH	Correction value for TH_UM set value in Warm-Up at 120°C or below under HH environment	1 - 99 45
AG	HL_LM WARMUP_120L HH	Correction value for TH_LM set value in Warm-Up at 120°C or below under HH environment	1 - 99 45
AH	HL_US WARMUP_120L HH	Correction value for TH_US set value in Warm-Up at 120°C or below under HH environment	1 - 99 45
AI	LO_WARMUP_TIME_HH	Correction value for AF-AH applying time (timer from Ready complete) under HH environment	1 - 99 50
AJ	HL_UM WARMUP_120H HH	Correction value for TH_UM set value in Warm-Up at 120°C or above under HH environment	1 - 99 45
AK	HL_LM WARMUP_120H HH	Correction value for TH_LM set value in Warm-Up at 120°C or above under HH environment	1 - 99 45
AL	HL_US WARMUP_120H HH	Correction value for TH_US set value in Warm-Up at 120°C or above under HH environment	1 - 99 45
AM	HI_WU_TIME_HH	Correction value for AJ-AL applying time (timer from Ready complete) under HH environment	1 - 99 50
AN	HI_WU_FM_ON_TMP_HH	Correction value for FM prior rotation start TH_US in Warm-Up at alpha °C or above under HH environment	1 - 99 50
AO	HI_WU_END_TIME_HH	Correction value for Warm-Up completion time in Warm-Up at alpha °C or above under HH environment	1 - 99 50
AP	HI_WU_JOB_SET_TMP_HH	Correction value for Job Enable TH_UM temperature in Warm-Up at alpha °C or above under HH environment	1 - 99 45
AQ	HI_WARMUP_BORDER_HH	Correction value for the threshold value alpha applying SIM43-1-AN - AP under HH environment	1 - 99 50



Item/Display		Content	Setting range	Default value
AR	LO_WU_JOB_SET_TMP_HH	Correction value for Job Enable TH_UM temperature in Warm-Up at alpha °C or below under HH environment	1 - 99	45
AS	JOBEND_FUMON_TIME LL	Correction value for the after rotation time when completing a job under HH environment	1 - 99	50
AT	HI_WU_JOB_SET_TMP_HH_B W	Correction value (BW) for Job enable TH_UM temperature when Warm-Up at alpha °C or above under HH environment	1 - 99	45

\* Item WARMUP END TIME HH: 1 Count = 1s Change  
Correction value for the other items: 1 count for 1°C change

#### Code descriptions

TH_UM	Fusing thermistor main (Front surface of paper)	HL_UM	Heater lamp main (Heat roller for front surface of paper)
TH_LM	Fusing thermistor main (Back surface of paper)	HL_LM	Heater lamp main (Heat roller for back surface of paper)
TH_US	Fusing thermistor sub (Front surface of paper)	HL_US	Heater lamp sub (Heat roller for front surface of paper)

<b>43-22</b>	
<b>Purpose</b>	Adjustment/Setup
<b>Function (Purpose)</b>	Used to set the environment correction under low temperature and low humidity (L/L) for the fusing temperature setting (SIM 43-4) in each paper mode.

#### Section

#### Operation/Procedure

- 1) Select an item to be set with scroll keys.
  - 2) Enter the set value with 10-key.
  - 3) Press [OK] key.
- The set value in step 2 is saved.

Correction value: -49 - +49, Input value: Actually inputted value (1 - 99)

Correction value	-49	-25	-5	0
Input value	1	25	45	50

#### 18cpm/20cpm machine

Item/Display		Content	Setting range	Default value
A	HL_UM PLAIN BW DUP LL	Correction value for upper TH_UM Black-White plain paper duplex under LL environment	1 - 99	55
B	HL_LM PLAIN BW DUP LL	Correction value for lower TH_LM Black-White plain paper duplex under LL environment	1 - 99	55
C	HL_US PLAIN BW DUP LL	Correction value for upper TH_US Black-White plain paper duplex under LL environment	1 - 99	55
D	PLAIN BW DUP APP CNT LL	Correction value for applying number of sheets in Black-White plain paper duplex under LL environment	1 - 99	50
E	HL_UM PLAIN CL DUP LL	Correction value for upper TH_UM Color plain paper duplex under LL environment	1 - 99	55
F	HL_LM PLAIN CL DUP LL	Correction value for lower TH_LM Color plain paper duplex under LL environment	1 - 99	55
G	HL_US PLAIN CL DUP LL	Correction value for upper TH_US Color plain paper duplex under LL environment	1 - 99	55
H	PLAIN CL DUP APP CNT LL	Correction value for applying number of sheets in Color plain paper duplex under LL environment	1 - 99	50
I	HL_UM HEAVY BW DUP LL	Correction value for upper TH_UM set value in Black-White heavy paper duplex under LL environment	1 - 99	55
J	HL_LM HEAVY BW DUP LL	Correction value for lower TH_LM set value in Black-White heavy paper duplex under LL environment	1 - 99	55
K	HL_US HEAVY BW DUP LL	Correction value for upper TH_US set value in Black-White heavy paper duplex under LL environment	1 - 99	55
L	HEAVY BW DUP APP CNT LL	Correction value for applying number of sheets in Black-White heavy paper duplex under LL environment	1 - 99	50
M	HL_UM HEAVY CL DUP LL	Correction value for upper TH_UM set value in Color heavy paper duplex under LL environment	1 - 99	55
N	HL_LM HEAVY CL DUP LL	Correction value for lower TH_LM set value in Color heavy paper duplex under LL environment	1 - 99	55
O	HL_US HEAVY CL DUP LL	Correction value for upper TH_US set value in Color heavy paper duplex under LL environment	1 - 99	55
P	HEAVY CL DUP APP CNT LL	Correction value for applying number of sheets in Color heavy paper duplex under LL environment	1 - 99	50

\* Items PLAIN BW DUP APP CNT LL/ PLAIN CL DUP APP CNT LL: 1 Count = 1s Change  
Correction value for the other items: 1 count for 1°C change

#### Code descriptions

TH_UM	Fusing thermistor main (Front surface of paper)	HL_UM	Heater lamp main (Heat roller for front surface of paper)
TH_LM	Fusing thermistor main (Back surface of paper)	HL_LM	Heater lamp main (Heat roller for back surface of paper)
TH_US	Fusing thermistor sub (Front surface of paper)	HL_US	Heater lamp sub (Heat roller for front surface of paper)

### 23cpm machine

	Item/Display	Content	Setting range	Default value
A	HL_UM PLAIN BW DUP LL	Correction value for upper TH_UM Black-White plain paper duplex under LL environment	1 - 99	55
B	HL_LM PLAIN BW DUP LL	Correction value for lower TH_LM Black-White plain paper duplex under LL environment	1 - 99	55
C	HL_US PLAIN BW DUP LL	Correction value for upper TH_US Black-White plain paper duplex under LL environment	1 - 99	55
D	PLAIN BW DUP APP CNT LL	Correction value for applying number of sheets in Black-White plain paper duplex under LL environment	1 - 99	50
E	HL_UM PLAIN CL DUP LL	Correction value for upper TH_UM Color plain paper duplex under LL environment	1 - 99	55
F	HL_LM PLAIN CL DUP LL	Correction value for lower TH_LM Color plain paper duplex under LL environment	1 - 99	55
G	HL_US PLAIN CL DUP LL	Correction value for upper TH_US Color plain paper duplex under LL environment	1 - 99	55
H	PLAIN CL DUP APP CNT LL	Correction value for applying number of sheets in Color plain paper duplex under LL environment	1 - 99	50
I	HL_UM HEAVY BW DUP LL	Correction value for upper TH_UM set value in Black-White heavy paper duplex under LL environment	1 - 99	55
J	HL_LM HEAVY BW DUP LL	Correction value for lower TH_LM set value in Black-White heavy paper duplex under LL environment	1 - 99	55
K	HL_US HEAVY BW DUP LL	Correction value for upper TH_US set value in Black-White heavy paper duplex under LL environment	1 - 99	55
L	HEAVY BW DUP APP CNT LL	Correction value for applying number of sheets in Black-White heavy paper duplex under LL environment	1 - 99	50
M	HL_UM HEAVY CL DUP LL	Correction value for upper TH_UM set value in Color heavy paper duplex under LL environment	1 - 99	55
N	HL_LM HEAVY CL DUP LL	Correction value for lower TH_LM set value in Color heavy paper duplex under LL environment	1 - 99	55
O	HL_US HEAVY CL DUP LL	Correction value for upper TH_US set value in Color heavy paper duplex under LL environment	1 - 99	55
P	HEAVY CL DUP APP CNT LL	Correction value for applying number of sheets in Color heavy paper duplex under LL environment	1 - 99	50

\* Items PLAIN BW DUP APP CNT LL/ PLAIN CL DUP APP CNT LL: 1 Count = 1s Change

Correction value for the other items: 1 count for 1°C change

#### Code descriptions

TH_UM	Fusing thermistor main (Front surface of paper)	HL_UM	Heater lamp main (Heat roller for front surface of paper)
TH_LM	Fusing thermistor main (Back surface of paper)	HL_LM	Heater lamp main (Heat roller for back surface of paper)
TH_US	Fusing thermistor sub (Front surface of paper)	HL_US	Heater lamp sub (Heat roller for front surface of paper)

### 26cpm/31cpm machine

	Item/Display	Content	Setting range	Default value
A	HL_UM PLAIN BW DUP LL	Correction value for upper TH_UM Black-White plain paper duplex under LL environment	1 - 99	55
B	HL_LM PLAIN BW DUP LL	Correction value for lower TH_LM Black-White plain paper duplex under LL environment	1 - 99	55
C	HL_US PLAIN BW DUP LL	Correction value for upper TH_US Black-White plain paper duplex under LL environment	1 - 99	55
D	PLAIN BW DUP APP CNT LL	Correction value for applying number of sheets in Black-White plain paper duplex under LL environment	1 - 99	50
E	HL_UM PLAIN CL DUP LL	Correction value for upper TH_UM Color plain paper duplex under LL environment	1 - 99	55
F	HL_LM PLAIN CL DUP LL	Correction value for lower TH_LM Color plain paper duplex under LL environment	1 - 99	55
G	HL_US PLAIN CL DUP LL	Correction value for upper TH_US Color plain paper duplex under LL environment	1 - 99	55
H	PLAIN CL DUP APP CNT LL	Correction value for applying number of sheets in Color plain paper duplex under LL environment	1 - 99	50
I	HL_UM HEAVY BW DUP LL	Correction value for upper TH_UM set value in Black-White heavy paper duplex under LL environment	1 - 99	55
J	HL_LM HEAVY BW DUP LL	Correction value for lower TH_LM set value in Black-White heavy paper duplex under LL environment	1 - 99	55
K	HL_US HEAVY BW DUP LL	Correction value for upper TH_US set value in Black-White heavy paper duplex under LL environment	1 - 99	55
L	HEAVY BW DUP APP CNT LL	Correction value for applying number of sheets in Black-White heavy paper duplex under LL environment	1 - 99	50
M	HL_UM HEAVY CL DUP LL	Correction value for upper TH_UM set value in Color heavy paper duplex under LL environment	1 - 99	55
N	HL_LM HEAVY CL DUP LL	Correction value for lower TH_LM set value in Color heavy paper duplex under LL environment	1 - 99	55
O	HL_US HEAVY CL DUP LL	Correction value for upper TH_US set value in Color heavy paper duplex under LL environment	1 - 99	55
P	HEAVY CL DUP APP CNT LL	Correction value for applying number of sheets in Color heavy paper duplex under LL environment	1 - 99	50

\* Items PLAIN BW DUP APP CNT LL/ PLAIN CL DUP APP CNT LL: 1 Count = 1s Change

Correction value for the other items: 1 count for 1°C change

#### Code descriptions

TH_UM	Fusing thermistor main (Front surface of paper)	HL_UM	Heater lamp main (Heat roller for front surface of paper)
TH_LM	Fusing thermistor main (Back surface of paper)	HL_LM	Heater lamp main (Heat roller for back surface of paper)
TH_US	Fusing thermistor sub (Front surface of paper)	HL_US	Heater lamp sub (Heat roller for front surface of paper)

**36cpm machine**

	Item/Display	Content	Setting range	Default value
A	HL_UM PLAIN BW DUP LL	Correction value for upper TH_UM Black-White plain paper duplex under LL environment	1 - 99	55
B	HL_LM PLAIN BW DUP LL	Correction value for lower TH_LM Black-White plain paper duplex under LL environment	1 - 99	55
C	HL_US PLAIN BW DUP LL	Correction value for upper TH_US Black-White plain paper duplex under LL environment	1 - 99	55
D	PLAIN BW DUP APP CNT LL	Correction value for applying number of sheets in Black-White plain paper duplex under LL environment	1 - 99	50
E	HL_UM PLAIN CL DUP LL	Correction value for upper TH_UM Color plain paper duplex under LL environment	1 - 99	55
F	HL_LM PLAIN CL DUP LL	Correction value for lower TH_LM Color plain paper duplex under LL environment	1 - 99	55
G	HL_US PLAIN CL DUP LL	Correction value for upper TH_US Color plain paper duplex under LL environment	1 - 99	55
H	PLAIN CL DUP APP CNT LL	Correction value for applying number of sheets in Color plain paper duplex under LL environment	1 - 99	50
I	HL_UM HEAVY BW DUP LL	Correction value for upper TH_UM set value in Black-White heavy paper duplex under LL environment	1 - 99	55
J	HL_LM HEAVY BW DUP LL	Correction value for lower TH_LM set value in Black-White heavy paper duplex under LL environment	1 - 99	55
K	HL_US HEAVY BW DUP LL	Correction value for upper TH_US set value in Black-White heavy paper duplex under LL environment	1 - 99	55
L	HEAVY BW DUP APP CNT LL	Correction value for applying number of sheets in Black-White heavy paper duplex under LL environment	1 - 99	50
M	HL_UM HEAVY CL DUP LL	Correction value for upper TH_UM set value in Color heavy paper duplex under LL environment	1 - 99	55
N	HL_LM HEAVY CL DUP LL	Correction value for lower TH_LM set value in Color heavy paper duplex under LL environment	1 - 99	55
O	HL_US HEAVY CL DUP LL	Correction value for upper TH_US set value in Color heavy paper duplex under LL environment	1 - 99	55
P	HEAVY CL DUP APP CNT LL	Correction value for applying number of sheets in Color heavy paper duplex under LL environment	1 - 99	50

\* Items PLAIN BW DUP APP CNT LL/ PLAIN CL DUP APP CNT LL: 1 Count = 1s Change  
Correction value for the other items: 1 count for 1°C change

**Code descriptions**

TH_UM	Fusing thermistor main (Front surface of paper)	HL_UM	Heater lamp main (Heat roller for front surface of paper)
TH_LM	Fusing thermistor main (Back surface of paper)	HL_LM	Heater lamp main (Heat roller for back surface of paper)
TH_US	Fusing thermistor sub (Front surface of paper)	HL_US	Heater lamp sub (Heat roller for front surface of paper)

<b>Purpose</b>	Adjustment/Setup
<b>Function (Purpose)</b>	Used to set the environment correction under high temperature and high humidity (H/H) for the fusing temperature setting (SIM 43-4) in each paper mode.

**Section****Operation/Procedure**

- 1) Select an item to be set with scroll keys.
- 2) Enter the set value with 10-key.
- 3) Press [OK] key.  
The set value in step 2) is saved.

Correction value: -49 - +49, Input value: Actually inputted value (1 - 99)

Correction value	-49	-25	-5	0
Input value	1	25	45	50

**18cpm/20cpm machine**

	Item/Display	Content	Setting range	Default value
A	HL_UM PLAIN BW DUP HH	Correction value for TH_UM Black-White plain paper duplex mode under HH environment	1 - 99	50
B	HL_LM PLAIN BW DUP HH	Correction value for TH_LM Black-White plain paper duplex mode under HH environment	1 - 99	50
C	HL_US PLAIN BW DUP HH	Correction value for TH_US Black-White plain paper duplex mode under HH environment	1 - 99	50
D	PLAIN BW DUP APP CNT HH	Correction value for applying number of sheets in Black-White plain paper duplex under HH environment	1 - 99	50
E	HL_UM PLAIN CL DUP HH	Correction value for TH_UM Color plain paper duplex mode under HH environment	1 - 99	50
F	HL_LM PLAIN CL DUP HH	Correction value for TH_LM Color plain paper duplex mode under HH environment	1 - 99	50
G	HL_US PLAIN CL DUP HH	Correction value for TH_US Color plain paper duplex mode under HH environment	1 - 99	50
H	PLAIN CL DUP APP CNT HH	Correction value for applying number of sheets in Color plain paper duplex under HH environment	1 - 99	50
I	HL_UM HEAVY BW DUP HH	Correction value for Black-White heavy paper duplex mode TH_UM set value under HH environment	1 - 99	50
J	HL_LM HEAVY BW DUP HH	Correction value for Black-White heavy paper duplex mode TH_LM set value under HH environment	1 - 99	50
K	HL_US HEAVY BW DUP HH	Correction value for Black-White heavy paper duplex mode TH_US set value under HH environment	1 - 99	50
L	HEAVY BW DUP APP CNT HH	Correction value for applying number of sheets in Black-White heavy paper duplex under HH environment	1 - 99	50
M	HL_UM HEAVY CL DUP HH	Correction value for Color heavy paper duplex mode TH_UM set value under HH environment	1 - 99	50
N	HL_LM HEAVY CL DUP HH	Correction value for Color heavy paper duplex mode TH_LM set value under HH environment	1 - 99	50
O	HL_US HEAVY CL DUP HH	Correction value for Color heavy paper duplex mode TH_US set value under HH environment	1 - 99	50
P	HEAVY CL DUP APP CNT HH	Correction value for applying number of sheets in Color heavy paper duplex under HH environment	1 - 99	50

- \* Items PLAIN BW DUP APP CNT HH/ PLAIN CL DUP APP CNT HH: 1 Count = 1s Change  
Correction value for the other items: 1 count for 1°C change

**Code descriptions**

TH_UM	Fusing thermistor main (Front surface of paper)	HL_UM	Heater lamp main (Heat roller for front surface of paper)
TH_LM	Fusing thermistor main (Back surface of paper)	HL_LM	Heater lamp main (Heat roller for back surface of paper)
TH_US	Fusing thermistor sub (Front surface of paper)	HL_US	Heater lamp sub (Heat roller for front surface of paper)

**23cpm machine**

	Item/Display	Content	Setting range	Default value
A	HL_UM PLAIN BW DUP HH	Correction value for TH_UM Black-White plain paper duplex mode under HH environment	1 - 99	50
B	HL_LM PLAIN BW DUP HH	Correction value for TH_LM Black-White plain paper duplex mode under HH environment	1 - 99	50
C	HL_US PLAIN BW DUP HH	Correction value for TH_US Black-White plain paper duplex mode under HH environment	1 - 99	50
D	PLAIN BW DUP APP CNT HH	Correction value for applying number of sheets in Black-White plain paper duplex under HH environment	1 - 99	50
E	HL_UM PLAIN CL DUP HH	Correction value for TH_UM Color plain paper duplex mode under HH environment	1 - 99	50
F	HL_LM PLAIN CL DUP HH	Correction value for TH_LM Color plain paper duplex mode under HH environment	1 - 99	50
G	HL_US PLAIN CL DUP HH	Correction value for TH_US Color plain paper duplex mode under HH environment	1 - 99	50
H	PLAIN CL DUP APP CNT HH	Correction value for applying number of sheets in Color plain paper duplex under HH environment	1 - 99	50
I	HL_UM HEAVY BW DUP HH	Correction value for Black-White heavy paper duplex mode TH_UM set value under HH environment	1 - 99	50
J	HL_LM HEAVY BW DUP HH	Correction value for Black-White heavy paper duplex mode TH_LM set value under HH environment	1 - 99	50
K	HL_US HEAVY BW DUP HH	Correction value for Black-White heavy paper duplex mode TH_US set value under HH environment	1 - 99	50
L	HEAVY BW DUP APP CNT HH	Correction value for applying number of sheets in Black-White heavy paper duplex under HH environment	1 - 99	50
M	HL_UM HEAVY CL DUP HH	Correction value for Color heavy paper duplex mode TH_UM set value under HH environment	1 - 99	50
N	HL_LM HEAVY CL DUP HH	Correction value for Color heavy paper duplex mode TH_LM set value under HH environment	1 - 99	50
O	HL_US HEAVY CL DUP HH	Correction value for Color heavy paper duplex mode TH_US set value under HH environment	1 - 99	50
P	HEAVY CL DUP APP CNT HH	Correction value for applying number of sheets in Color heavy paper duplex under HH environment	1 - 99	50

- \* Items PLAIN BW DUP APP CNT HH/ PLAIN CL DUP APP CNT HH: 1 Count = 1s Change  
Correction value for the other items: 1 count for 1°C change

**Code descriptions**

TH_UM	Fusing thermistor main (Front surface of paper)	HL_UM	Heater lamp main (Heat roller for front surface of paper)
TH_LM	Fusing thermistor main (Back surface of paper)	HL_LM	Heater lamp main (Heat roller for back surface of paper)
TH_US	Fusing thermistor sub (Front surface of paper)	HL_US	Heater lamp sub (Heat roller for front surface of paper)

**26cpm/31cpm machine**

	Item/Display	Content	Setting range	Default value
A	HL_UM PLAIN BW DUP HH	Correction value for TH_UM Black-White plain paper duplex mode under HH environment	1 - 99	50
B	HL_LM PLAIN BW DUP HH	Correction value for TH_LM Black-White plain paper duplex mode under HH environment	1 - 99	50
C	HL_US PLAIN BW DUP HH	Correction value for TH_US Black-White plain paper duplex mode under HH environment	1 - 99	50
D	PLAIN BW DUP APP CNT HH	Correction value for applying number of sheets in Black-White plain paper duplex under HH environment	1 - 99	50
E	HL_UM PLAIN CL DUP HH	Correction value for TH_UM Color plain paper duplex mode under HH environment	1 - 99	50
F	HL_LM PLAIN CL DUP HH	Correction value for TH_LM Color plain paper duplex mode under HH environment	1 - 99	50
G	HL_US PLAIN CL DUP HH	Correction value for TH_US Color plain paper duplex mode under HH environment	1 - 99	50
H	PLAIN CL DUP APP CNT HH	Correction value for applying number of sheets in Color plain paper duplex under HH environment	1 - 99	50
I	HL_UM HEAVY BW DUP HH	Correction value for Black-White heavy paper duplex mode TH_UM set value under HH environment	1 - 99	50
J	HL_LM HEAVY BW DUP HH	Correction value for Black-White heavy paper duplex mode TH_LM set value under HH environment	1 - 99	50
K	HL_US HEAVY BW DUP HH	Correction value for Black-White heavy paper duplex mode TH_US set value under HH environment	1 - 99	50
L	HEAVY BW DUP APP CNT HH	Correction value for applying number of sheets in Black-White heavy paper duplex under HH environment	1 - 99	50
M	HL_UM HEAVY CL DUP HH	Correction value for Color heavy paper duplex mode TH_UM set value under HH environment	1 - 99	50
N	HL_LM HEAVY CL DUP HH	Correction value for Color heavy paper duplex mode TH_LM set value under HH environment	1 - 99	50
O	HL_US HEAVY CL DUP HH	Correction value for Color heavy paper duplex mode TH_US set value under HH environment	1 - 99	50
P	HEAVY CL DUP APP CNT HH	Correction value for applying number of sheets in Color heavy paper duplex under HH environment	1 - 99	50

\* Items PLAIN BW DUP APP CNT HH/ PLAIN CL DUP APP CNT HH: 1 Count = 1s Change  
Correction value for the other items: 1 count for 1°C change

**Code descriptions**

TH_UM	Fusing thermistor main (Front surface of paper)	HL_UM	Heater lamp main (Heat roller for front surface of paper)
TH_LM	Fusing thermistor main (Back surface of paper)	HL_LM	Heater lamp main (Heat roller for back surface of paper)
TH_US	Fusing thermistor sub (Front surface of paper)	HL_US	Heater lamp sub (Heat roller for front surface of paper)

**36cpm machine**

	Item/Display	Content	Setting range	Default value
A	HL_UM PLAIN BW DUP HH	Correction value for TH_UM Black-White plain paper duplex mode under HH environment	1 - 99	50
B	HL_LM PLAIN BW DUP HH	Correction value for TH_LM Black-White plain paper duplex mode under HH environment	1 - 99	50
C	HL_US PLAIN BW DUP HH	Correction value for TH_US Black-White plain paper duplex mode under HH environment	1 - 99	50
D	PLAIN BW DUP APP CNT HH	Correction value for applying number of sheets in Black-White plain paper duplex under HH environment	1 - 99	50
E	HL_UM PLAIN CL DUP HH	Correction value for TH_UM Color plain paper duplex mode under HH environment	1 - 99	50
F	HL_LM PLAIN CL DUP HH	Correction value for TH_LM Color plain paper duplex mode under HH environment	1 - 99	50
G	HL_US PLAIN CL DUP HH	Correction value for TH_US Color plain paper duplex mode under HH environment	1 - 99	50
H	PLAIN CL DUP APP CNT HH	Correction value for applying number of sheets in Color plain paper duplex under HH environment	1 - 99	50
I	HL_UM HEAVY BW DUP HH	Correction value for Black-White heavy paper duplex mode TH_UM set value under HH environment	1 - 99	50
J	HL_LM HEAVY BW DUP HH	Correction value for Black-White heavy paper duplex mode TH_LM set value under HH environment	1 - 99	50
K	HL_US HEAVY BW DUP HH	Correction value for Black-White heavy paper duplex mode TH_US set value under HH environment	1 - 99	50
L	HEAVY BW DUP APP CNT HH	Correction value for applying number of sheets in Black-White heavy paper duplex under HH environment	1 - 99	50
M	HL_UM HEAVY CL DUP HH	Correction value for Color heavy paper duplex mode TH_UM set value under HH environment	1 - 99	50
N	HL_LM HEAVY CL DUP HH	Correction value for Color heavy paper duplex mode TH_LM set value under HH environment	1 - 99	50
O	HL_US HEAVY CL DUP HH	Correction value for Color heavy paper duplex mode TH_US set value under HH environment	1 - 99	50
P	HEAVY CL DUP APP CNT HH	Correction value for applying number of sheets in Color heavy paper duplex under HH environment	1 - 99	50

\* Items PLAIN BW DUP APP CNT HH/ PLAIN CL DUP APP CNT HH: 1 Count = 1s Change  
Correction value for the other items: 1 count for 1°C change

**Code descriptions**

TH_UM	Fusing thermistor main (Front surface of paper)	HL_UM	Heater lamp main (Heat roller for front surface of paper)
TH_LM	Fusing thermistor main (Back surface of paper)	HL_LM	Heater lamp main (Heat roller for back surface of paper)
TH_US	Fusing thermistor sub (Front surface of paper)	HL_US	Heater lamp sub (Heat roller for front surface of paper)

<b>Purpose</b>	Adjustment/Setup
<b>Function (Purpose)</b>	Used to set the correction of the temperature adjustment value of SIM 43-1 and 43-4.

**Section****Operation/Procedure**

- 1) Select an item to be set with scroll keys.
- 2) Enter the set value with 10-key.
- 3) Press [OK] key.

The set value in step 2 is saved.

Correction value: -49 - +49, Input value: Actually inputted value (1 - 99)

Correction value	-49	-25	-5	0	5	25	49
Input value	1	25	45	50	55	75	99

**18cpm/20cpm machine**

	Item/Display	Content	Default value (SW-A)			Default value (SW-B)		
			Group A	Group B	Group C	Group A	Group B	Group C
A	NN_120_FUS_DUP_HL_UM	Correction value for SIM43-4-A, E at 120°C or below in N/N Warm-Up	50	50	50	50	50	50
B	NN_120_FUS_DUP_HL_LM	Correction value for SIM43-4-B, F at 120°C or below in N/N Warm-Up	50	50	50	50	50	50
C	LL_120_FUS_DUP_HL_UM	Correction value for SIM43-22-A, E at 120°C or below in N/N Warm-Up	50	50	50	50	50	50
D	LL_120_FUS_DUP_HL_LM	Correction value for SIM43-22-B, F at 120°C or below in N/N Warm-Up	50	50	50	50	50	50
E	HH_120_FUS_DUP_HL_UM	Correction value for SIM43-23-A, E at 120°C or below in N/N Warm-Up	50	50	50	50	50	50
F	HH_120_FUS_DUP_HL_LM	Correction value for SIM43-23-B, F at 120°C or below in N/N Warm-Up	50	50	50	50	50	50
G	NN_120_FUS_DUP_CNT	Fusing duplex paper exit count under NN environment	5	5	5	5	5	5
H	LL_120_FUS_DUP_CNT	Fusing duplex paper exit count under LL environment	10	10	10	10	10	10
I	HH_120_FUS_DUP_CNT	Fusing duplex paper exit count under HH environment	5	5	5	5	5	5
J	COOL_DOWN_HEAVY	Cool down time heavy paper	5	5	5	5	5	5
K	COOL_DOWN_OHP	Cool down time OHP	10	10	10	10	10	10
L	COOL_DOWN_ENVELOPE	Cool down time envelope	15	15	15	15	15	15
M	NN_120_FUS_DUP_HL_US	Correction value for SIM43-4-C, G at 120°C or below in N/N Warm-Up	50	50	50	50	50	50
N	LL_120_FUS_DUP_HL_US	Correction value for SIM43-22-C, G at 120°C or below in L/L Warm-Up	50	50	50	50	50	50
O	HH_120_FUS_DUP_HL_US	Correction value for SIM43-23-C, G at 120°C or below in H/H Warm-Up	50	50	50	50	50	50
P	HL_UM THIN PAPER BW	Thin paper BW-TH_UM	130	130	130	130	130	130
Q	HL_LM THIN PAPER BW	Thin paper BW-TH_LM	120	120	120	120	120	120
R	HL_US THIN PAPER BW	Thin paper BW-TH_US	130	130	130	130	130	130
S	HL_UM THIN PAPER CL	Thin paper COL-TH_UM	140	140	140	140	140	140
T	HL_LM THIN PAPER CL	Thin paper COL-TH_LM	130	130	130	130	130	130
U	HL_US THIN PAPER CL	Thin paper COL-TH_US	140	140	140	140	140	140
V	HL_UM THIN PAPER READY	Thin paper Ready-TH_UM	145	145	145	145	145	145
W	HL_UM REC PAPER BW	Recycled paper BW-TH_UM	135	160	160	135	160	160
X	HL_LM REC PAPER BW	Recycled paper BW-TH_LM	125	140	140	125	140	140
Y	HL_US REC PAPER BW	Recycled paper BW-TH_US	135	155	155	135	155	155
Z	HL_UM REC PAPER CL	Recycled paper COL-TH_UM	145	170	170	145	170	170
AA	HL_LM REC PAPER CL	Recycled paper COL-TH_LM	135	140	140	135	140	140
AB	HL_US REC PAPER CL	Recycled paper COL-TH_US	145	160	160	145	160	160
AC	HL_UM REC PAPER READY	Recycled paper Ready-TH_UM	155	180	180	155	180	180

\* Each temperature correction value: 1 count for 1°C change in temperature control

\* Each paper exit count: 1 count = 1 sheet change

\* Each cool down time: 1 count = 1sec change

**Code descriptions**

TH_UM	Fusing thermistor main (Front surface of paper)	HL_UM	Heater lamp main (Heat roller for front surface of paper)
TH_LM	Fusing thermistor main (Back surface of paper)	HL_LM	Heater lamp main (Heat roller for back surface of paper)
TH_US	Fusing thermistor sub (Front surface of paper)	HL_US	Heater lamp sub (Heat roller for front surface of paper)

SW-A Setting value when plain paper is selected in the system setting/device setting/fusing control setting.

SW-B Set value when heavy paper is selected in the system setting/device setting/fusing control setting.

The set value displayed in this simulation differs depending on plain paper or heavy paper which is selected in the system setting/device setting/fusing control setting.

(Example) When plain paper is selected in the system setting/device setting/fusing control setting, the value of SW-A is displayed.

**List of destination groups**

Group	Destination				
Group A	JAPAN	–	–	–	–
Group B	U. S. A	CANADA	INCH	–	–
Group C	EUROPE	U. K	AUS.	AB_B	CHINA

**23cpm machine**

Item/Display		Content	Default value (SW-A)			Default value (SW-B)		
			Group A	Group B	Group C	Group A	Group B	Group C
A	NN_120_FUS_DUP_HL_UM	Correction value for SIM43-4-A, E at 120°C or below in N/N Warm-Up	50	50	50	50	50	50
B	NN_120_FUS_DUP_HL_LM	Correction value for SIM43-4-B, F at 120°C or below in N/N Warm-Up	50	50	50	50	50	50
C	LL_120_FUS_DUP_HL_UM	Correction value for SIM43-22-A, E at 120°C or below in N/N Warm-Up	50	50	50	50	50	50
D	LL_120_FUS_DUP_HL_LM	Correction value for SIM43-22-B, F at 120°C or below in N/N Warm-Up	50	50	50	50	50	50
E	HH_120_FUS_DUP_HL_UM	Correction value for SIM43-23-A, E at 120°C or below in N/N Warm-Up	50	50	50	50	50	50
F	HH_120_FUS_DUP_HL_LM	Correction value for SIM43-23-B, F at 120°C or below in N/N Warm-Up	50	50	50	50	50	50
G	NN_120_FUS_DUP_CNT	Fusing duplex paper exit count under NN environment	5	5	5	5	5	5
H	LL_120_FUS_DUP_CNT	Fusing duplex paper exit count under LL environment	10	10	10	10	10	10
I	HH_120_FUS_DUP_CNT	Fusing duplex paper exit count under HH environment	5	5	5	5	5	5
J	COOL_DOWN_HEAVY	Cool down time heavy paper	5	5	5	5	5	5
K	COOL_DOWN_OHP	Cool down time OHP	10	10	10	10	10	10
L	COOL_DOWN_ENVELOPE	Cool down time envelope	15	15	15	15	15	15
M	NN_120_FUS_DUP_HL_US	Correction value for SIM43-4-C, G at 120°C or below in N/N Warm-Up	50	50	50	50	50	50
N	LL_120_FUS_DUP_HL_US	Correction value for SIM43-22-C, G at 120°C or below in L/L Warm-Up	50	50	50	50	50	50
O	HH_120_FUS_DUP_HL_US	Correction value for SIM43-23-C, G at 120°C or below in H/H Warm-Up	50	50	50	50	50	50
P	HL_UM THIN PAPER BW	Thin paper BW-TH_UM	115	115	115	115	115	115
Q	HL_LM THIN PAPER BW	Thin paper BW-TH_LM	105	105	105	105	105	105
R	HL_US THIN PAPER BW	Thin paper BW-TH_US	125	125	125	125	125	125
S	HL_UM THIN PAPER CL	Thin paper COL-TH_UM	115	115	115	115	115	115
T	HL_LM THIN PAPER CL	Thin paper COL-TH_LM	105	105	105	105	105	105
U	HL_US THIN PAPER CL	Thin paper COL-TH_US	125	125	125	125	125	125
V	HL_UM THIN PAPER READY	Thin paper Ready-TH_UM	120	120	120	120	120	120
W	HL_UM REC PAPER BW	Recycled paper BW-TH_UM	130	135	135	130	135	135
X	HL_LM REC PAPER BW	Recycled paper BW-TH_LM	110	110	110	110	110	110
Y	HL_US REC PAPER BW	Recycled paper BW-TH_US	135	150	150	135	150	150
Z	HL_UM REC PAPER CL	Recycled paper COL-TH_UM	130	135	135	130	135	135
AA	HL_LM REC PAPER CL	Recycled paper COL-TH_LM	110	110	110	110	110	110
AB	HL_US REC PAPER CL	Recycled paper COL-TH_US	135	150	150	135	150	150
AC	HL_UM REC PAPER READY	Recycled paper Ready-TH_UM	140	145	145	140	145	145

\* Each temperature correction value: 1 count for 1°C change in temperature control

\* Each paper exit count: 1 count = 1 sheet change

\* Each cool down time: 1 count = 1sec change

**Code descriptions**

TH_UM	Fusing thermistor main (Front surface of paper)	HL_UM	Heater lamp main (Heat roller for front surface of paper)
TH_LM	Fusing thermistor main (Back surface of paper)	HL_LM	Heater lamp main (Heat roller for back surface of paper)
TH_US	Fusing thermistor sub (Front surface of paper)	HL_US	Heater lamp sub (Heat roller for front surface of paper)

SW-A Setting value when plain paper is selected in the system setting/device setting/fusing control setting.

SW-B Set value when heavy paper is selected in the system setting/device setting/fusing control setting.

The set value displayed in this simulation differs depending on plain paper or heavy paper which is selected in the system setting/device setting/fusing control setting.

(Example) When plain paper is selected in the system setting/device setting/fusing control setting, the value of SW-A is displayed.

**List of destination groups**

Group	Destination				
Group A	JAPAN	–	–	–	–
Group B	U. S. A	CANADA	INCH	–	–
Group C	EUROPE	U. K	AUS.	AB_B	CHINA

26cpm/31cpm machine

Item/Display		Content	Default value (SW-A)			Default value (SW-B)		
			Group A	Group B	Group C	Group A	Group B	Group C
A	NN_120_FUS_DUP_HL_UM	Correction value for SIM43-4-A, E at 120°C or below in N/N Warm-Up	50	50	50	50	50	50
B	NN_120_FUS_DUP_HL_LM	Correction value for SIM43-4-B, F at 120°C or below in N/N Warm-Up	50	50	50	50	50	50
C	LL_120_FUS_DUP_HL_UM	Correction value for SIM43-22-A, E at 120°C or below in N/N Warm-Up	50	50	50	50	50	50
D	LL_120_FUS_DUP_HL_LM	Correction value for SIM43-22-B, F at 120°C or below in N/N Warm-Up	50	50	50	50	50	50
E	HH_120_FUS_DUP_HL_UM	Correction value for SIM43-23-A, E at 120°C or below in N/N Warm-Up	50	50	50	50	50	50
F	HH_120_FUS_DUP_HL_LM	Correction value for SIM43-23-B, F at 120°C or below in N/N Warm-Up	50	50	50	50	50	50
G	NN_120_FUS_DUP_CNT	Fusing duplex paper exit count under NN environment	5	5	5	5	5	5
H	LL_120_FUS_DUP_CNT	Fusing duplex paper exit count under LL environment	10	10	10	10	10	10
I	HH_120_FUS_DUP_CNT	Fusing duplex paper exit count under HH environment	5	5	5	5	5	5
J	COOL_DOWN_HEAVY	Cool down time heavy paper	5	5	5	5	5	5
K	COOL_DOWN_OHP	Cool down time OHP	10	10	10	10	10	10
L	COOL_DOWN_ENVELOPE	Cool down time envelope	15	15	15	15	15	15
M	NN_120_FUS_DUP_HL_US	Correction value for SIM43-4-C, G at 120°C or below in N/N Warm-Up	50	50	50	50	50	50
N	LL_120_FUS_DUP_HL_US	Correction value for SIM43-22-C, G at 120°C or below in L/L Warm-Up	50	50	50	50	50	50
O	HH_120_FUS_DUP_HL_US	Correction value for SIM43-23-C, G at 120°C or below in H/H Warm-Up	50	50	50	50	50	50
P	HL_UM THIN PAPER BW	Thin paper BW-TH_UM	115	115	115	115	115	115
Q	HL_LM THIN PAPER BW	Thin paper BW-TH_LM	105	105	105	105	105	105
R	HL_US THIN PAPER BW	Thin paper BW-TH_US	135	135	135	135	135	135
S	HL_UM THIN PAPER CL	Thin paper COL-TH_UM	115	115	115	115	115	115
T	HL_LM THIN PAPER CL	Thin paper COL-TH_LM	105	105	105	105	105	105
U	HL_US THIN PAPER CL	Thin paper COL-TH_US	135	135	135	135	135	135
V	HL_UM THIN PAPER READY	Thin paper Ready-TH_UM	120	120	120	120	120	120
W	HL_UM REC PAPER BW	Recycled paper BW-TH_UM	130	135	140	130	135	140
X	HL_LM REC PAPER BW	Recycled paper BW-TH_LM	110	110	110	110	110	110
Y	HL_US REC PAPER BW	Recycled paper BW-TH_US	140	155	165	140	155	165
Z	HL_UM REC PAPER CL	Recycled paper COL-TH_UM	130	135	140	130	135	140
AA	HL_LM REC PAPER CL	Recycled paper COL-TH_LM	110	110	110	110	110	110
AB	HL_US REC PAPER CL	Recycled paper COL-TH_US	140	155	165	140	155	165
AC	HL_UM REC PAPER READY	Recycled paper Ready-TH_UM	140	145	150	140	145	150

\* Each temperature correction value: 1 count for 1°C change in temperature control

\* Each paper exit count: 1 count = 1 sheet change

\* Each cool down time: 1 count = 1sec change

**Code descriptions**

TH_UM	Fusing thermistor main (Front surface of paper)	HL_UM	Heater lamp main (Heat roller for front surface of paper)
TH_LM	Fusing thermistor main (Back surface of paper)	HL_LM	Heater lamp main (Heat roller for back surface of paper)
TH_US	Fusing thermistor sub (Front surface of paper)	HL_US	Heater lamp sub (Heat roller for front surface of paper)

SW-A Setting value when plain paper is selected in the system setting/device setting/fusing control setting.

SW-B Set value when heavy paper is selected in the system setting/device setting/fusing control setting.

The set value displayed in this simulation differs depending on plain paper or heavy paper which is selected in the system setting/device setting/fusing control setting.

(Example) When plain paper is selected in the system setting/device setting/fusing control setting, the value of SW-A is displayed.

**List of destination groups**

Group	Destination				
Group A	JAPAN	-	-	-	-
Group B	U. S. A	CANADA	INCH	-	-
Group C	EUROPE	U. K	AUS.	AB_B	CHINA



### 36cpm machine

Item/Display		Content	Default value		
			Group A	Group B	Group C
A	NN_120_FUS_DUP_HL_UM	Correction value for SIM43-4-A, E at 120°C or below in N/N Warm-Up	50	50	50
B	NN_120_FUS_DUP_HL_LM	Correction value for SIM43-4-B, F at 120°C or below in N/N Warm-Up	50	50	50
C	LL_120_FUS_DUP_HL_UM	Correction value for SIM43-22-A, E at 120°C or below in N/N Warm-Up	50	50	50
D	LL_120_FUS_DUP_HL_LM	Correction value for SIM43-22-B, F at 120°C or below in N/N Warm-Up	50	50	50
E	HH_120_FUS_DUP_HL_UM	Correction value for SIM43-23-A, E at 120°C or below in N/N Warm-Up	50	50	50
F	HH_120_FUS_DUP_HL_LM	Correction value for SIM43-23-B, F at 120°C or below in N/N Warm-Up	50	50	50
G	NN_120_FUS_DUP_CNT	Fusing duplex paper exit count under NN environment	5	5	5
H	LL_120_FUS_DUP_CNT	Fusing duplex paper exit count under LL environment	10	10	10
I	HH_120_FUS_DUP_CNT	Fusing duplex paper exit count under HH environment	5	5	5
J	COOL_DOWN_HEAVY	Cool down time heavy paper	5	5	5
K	COOL_DOWN_OHP	Cool down time OHP	10	10	10
L	COOL_DOWN_ENVELOPE	Cool down time envelope	15	15	15
M	FUSER MOTOR	Web send quantity	10	10	10
N	NN_120_FUS_DUP_HL_US	Correction value for SIM43-4-C, G at 120°C or below in N/N Warm-Up	50	50	50
O	LL_120_FUS_DUP_HL_US	Correction value for SIM43-22-C, G at 120°C or below in L/L Warm-Up	50	50	50
P	HH_120_FUS_DUP_HL_US	Correction value for SIM43-23-C, G at 120°C or below in H/H Warm-Up	50	50	50
Q	HL_UM THIN PAPER BW	Thin paper BW-TH_UM	125	125	125
R	HL_LM THIN PAPER BW	Thin paper BW-TH_LM	105	105	105
S	HL_US THIN PAPER BW	Thin paper BW-TH_US	140	140	140
T	HL_UM THIN PAPER CL	Thin paper COL-TH_UM	125	125	125
U	HL_LM THIN PAPER CL	Thin paper COL-TH_LM	105	105	105
V	HL_US THIN PAPER CL	Thin paper COL-TH_US	140	140	140
W	HL_UM THIN PAPER READY	Thin paper Ready-TH_UM	130	130	130
X	HL_UM REC PAPER BW	Recycled paper BW-TH_UM	130	140	150
Y	HL_LM REC PAPER BW	Recycled paper BW-TH_LM	110	110	110
Z	HL_US REC PAPER BW	Recycled paper BW-TH_US	145	160	170
AA	HL_UM REC PAPER CL	Recycled paper COL-TH_UM	130	140	150
AB	HL_LM REC PAPER CL	Recycled paper COL-TH_LM	110	110	110
AC	HL_US REC PAPER CL	Recycled paper COL-TH_US	145	160	170
AD	HL_UM REC PAPER READY	Recycled paper Ready-TH_UM	140	150	160

\* Each temperature correction value: 1 count for 1°C change in temperature control

\* Each paper exit count: 1 count = 1 sheet change

\* Each cool down time: 1 count = 1sec change

#### Code descriptions

TH_UM	Fusing thermistor main (Front surface of paper)	HL_UM	Heater lamp main (Heat roller for front surface of paper)
TH_LM	Fusing thermistor main (Back surface of paper)	HL_LM	Heater lamp main (Heat roller for back surface of paper)
TH_US	Fusing thermistor sub (Front surface of paper)	HL_US	Heater lamp sub (Heat roller for front surface of paper)

SW-A Setting value when plain paper is selected in the system setting/device setting/fusing control setting.

SW-B Set value when heavy paper is selected in the system setting/device setting/fusing control setting.

The set value displayed in this simulation differs depending on plain paper or heavy paper which is selected in the system setting/device setting/fusing control setting.

(Example) When plain paper is selected in the system setting/device setting/fusing control setting, the value of SW-A is displayed.

#### List of destination groups

Group	Destination				
Group A	JAPAN	-	-	-	-
Group B	U. S. A	CANADA	INCH	-	-
Group C	EUROPE	U. K	AUS.	AB_B	CHINA

43-31

<b>Purpose</b>	Adjustment/Setup
<b>Function (Purpose)</b>	Used to check the operation of the fusing web cleaning. (36cpm machine)
<b>Section</b>	Fusing

**Operation/Procedure**

- 1) Press [EXECUTE] key.  
Cleaning the fusing web is performed.
- 2) When cleaning the fusing web is completed, "COMPLETE" is displayed.

**Note**

The set value may be changed for a design change or an individual arrangement. Except for the above cases, however, the set value must not be changed. If it is changed, a trouble may be occur.

Fusing web unit installation detection state	Operation	Remarks
Fusing web unit not installed	Does not operate	* During this operation, the fusing web cleaning feed counter is counted up.
Fusing web unit installed	Operates for the specified time.	

43-32

<b>Purpose</b>	Adjustment/Setup
<b>Function (Purpose)</b>	Used to set various items related to the forcible operation of web cleaning when job end. (36cpm machine)
<b>Section</b>	Fusing

**Operation/Procedure**

- 1) Select an item to be set with the scroll key.
- 2) Enter the set value with 10-key.
- 3) Press [OK] key.  
The set value in step 2) is saved.

**Note**

The set value may be changed for a design change or an individual arrangement. Except for the above cases, however, the set value must not be changed. If it is changed, a trouble may be occur.

Item/Display	Item	Setting range	Default value
A	JOB END COMPACT CHECK Fusing web motor forcible operation condition when job end	Enable Disable	0 - 1 0 1 1
B	JOB END COMPACT INTERVAL Interval of the print quantity of compulsory action of the fusing web motor at job end		1 - 200 100
C	JOB END COMPACT CNT Number of forcible operations of the fusing web motor when job end		1 - 5 1

44

44-1

<b>Purpose</b>	Setting
<b>Function (Purpose)</b>	Used to set each correction operation function in the image forming (process) section.
<b>Section</b>	Image process (Photoconductor/Developing/Transfer/Cleaning)

**Operation/Procedure**

- 1) Select an item to be set with the touch panel.  
(The selected item is highlighted.)
- 2) Press [EXECUTE] key. (The set value is saved.)

**Important**

Set the items to the default values unless a change is specially required.

Item/Display	Content	Setting range	Default value	NOTE
HV	Normal operation high density process control Enable/Disable setting	Normal (Disable: 1: NO) Reverse (Enable: 0: YES)	Enable	
HT	Normal operation halftone process control Enable/Disable setting		Enable	
TC	Transfer output correction Enable/Disable setting		Enable	
MD VG	Membrane decrease grid voltage correction Enable/Disable setting		Enable	
MD LD	Membrane laser power voltage correction Enable/Disable setting		Disable	
MD EV	Membrane decrease environment grid voltage correction Enable/Disable setting		Enable	
MD DL	Membrane decrease discharge light quantity correction Enable/Disable setting		Enable	
MD DL EV	Membrane decrease environment discharge light quantity correction Enable/Disable setting		Disable	
TN_PIX_SUP	Setting of Enable/Disable of toner supply control for the yield count		Enable	
TN_FB	Setting of Enable/Disable of the toner density correction for the process control result		Enable	
TN_INT	Setting of Enable/Disable of toner compulsory supply correction for the development traveling distance	Enable		
TN_RECV	Setting of Enable/Disable of the toner density recovery operation	Enable		
TN_ADJ	Setting of Enable/Disable of the toner sensor control voltage adjustment in the process control	Enable		

Item/Display	Content	Setting range	Default value	NOTE
TN_EMP	Setting of Enable/Disable of the toner falling distance detection control	Normal (Disable: 1: NO) Reverse (Enable: 0: YES)	Enable	
TN_EMP_INT	Setting of Enable/Disable of the toner falling distance detection control of job interruption		Enable	
TN_EMP_NEW	Setting of Enable/Disable of the new toner cartridge falling distance detection control		Enable	
TN_PIX_TBL	Setting of Enable/Disable of execution of revision of the yield count conversion table for the toner supply control in the halftone process control		Enable	
AR_AUTO	Auto registration adjustment Enable/Disable setting		Enable	
AR_ERROR	Auto registration adjustment execution error check Enable/Disable setting		Enable	
DM_PHASE	Drum phase fitting Enable/Disable setting		Enable	
PRT_HT	Halftone process control printer correction feedback Enable/Disable setting		Enable	
PTC_ENV	PTC environment correction Enable/Disable setting		Enable	Enable: Correction ON

44-2

<b>Purpose</b>	Adjustment/Setup
<b>Function (Purpose)</b>	Used to adjust the sensitivity of the image density sensor (registration sensor).
<b>Section</b>	Process

#### Operation/Procedure

When [EXECUTE] key is pressed, the adjustment is executed automatically.

After completion of the adjustment, the adjustment result is displayed.

If the adjustment is not executed normally, "ERROR" is displayed.

Classification	Item/Display	Content	Setting range	Default value
PROCON	A	PCS_CL LED ADJ	Color image sensor light emitting quantity adjustment value	1 - 255 21
	B	PCS_K LED ADJ	Black image sensor light emitting quantity adjustment value	1 - 255 21
	C	PCS_CL DARK	Dark voltage of color image sensor	0 - 255 0
	D	PCS_K DARK	Dark voltage of black image sensor	0 - 255 0
	E	PCS_K GRND	Transfer belt substrate detection level when the item B adjustment is completed	0 - 255 0

Classification	Item/Display	Content	Setting range	Default value
PROCON	F	PCS_K BELT MAX	Transfer belt substrate input max. value	0 - 255 0
	G	PCS_K BELT MIN	Transfer belt substrate input min. value	0 - 255 0
	H	PCS_K BELT DIF	Transfer belt substrate input difference (Item E - Item F)	0 - 255 0
REGIST	I	REG_F LED ADJ	Registration sensor light emitting quantity adjustment value F	1 - 255 56
	J	REG_F DARK	Registration sensor dark voltage F	0 - 255 0
	K	REG_F GRND	Transfer belt substrate detection level when the item I adjustment is completed	0 - 255 0
	L	REG_R LED ADJ	Registration sensor light emitting quantity adjustment value R	1 - 255 56
	M	REG_R DARK	Registration sensor dark voltage R	0 - 255 0
	N	REG_R GRND	Transfer belt substrate detection level when the item J adjustment is completed	0 - 256 0
	O	REG_F BELT MAX	Transfer belt substrate detection level max. value (F side)	0 - 255 0
	P	REG_F BELT MIN	Transfer belt substrate detection level min. value (F side)	0 - 255 0
	Q	REG_F BELT DIF	Transfer belt substrate detection level difference (Item O - Item P)	0 - 255 0
	R	REG_R BELT MAX	Transfer belt substrate detection level max. value (R side)	0 - 255 0
	S	REG_R BELT MIN	Transfer belt substrate detection level min. value (R side)	0 - 255 0
	T	REG_R BELT DIF	Transfer belt substrate detection level difference (Item R - Item S)	0 - 255 0
	U	REG_F PATCH (K)	Toner patch detection level F (K) in the registration adjustment	0 - 255 0
	V	REG_F PATCH (C)	Toner patch detection level F (C) in the registration adjustment	0 - 255 0
	W	REG_F PATCH (M)	Toner patch detection level F (M) in the registration adjustment	0 - 255 0

Classification	Item/Display		Content	Setting range	Default value
REGIST	X	REG_F PATCH (Y)	Toner patch detection level F (Y) in the registration adjustment	0 - 255	0
	Y	REG_R PATCH (K)	Toner patch detection level R (K) in the registration adjustment	0 - 255	0
	Z	REG_R PATCH (C)	Toner patch detection level R (C) in the registration adjustment	0 - 255	0
	AA	REG_R PATCH (M)	Toner patch detection level R (M) in the registration adjustment	0 - 255	0
	AB	REG_R PATCH (Y)	Toner patch detection level R (Y) in the registration adjustment	0 - 255	0

Error name	Error content
Black sensor adjustment abnormality	PCS_K LED ADJ error The target is not reached by 3 times of adjustments.
Color sensor adjustment abnormality	PCS_CL LED ADJ error The target is not reached by 3 times of adjustments.
Substrate scan abnormality	PCS_K GRND error The difference between the max. value and the min. value of the substrate detection level is greater than the specified value when the transfer belt rotates one turn.
Registration sensor F adjustment abnormality	REG_F LED ADJ error The target is not reached by 3 times of adjustments.
Registration sensor R adjustment abnormality	REG_R LED ADJ error The target is not reached by 3 times of adjustments.
Registration substrate F scan abnormality	REG_F GRND error The difference between the max. value and the min. value of the substrate detection level is greater than the specified value when the transfer belt rotates one turn.
Registration substrate R scan abnormality	REG_R GRND error The difference between the max. value and the min. value of the substrate detection level is greater than the specified value when the transfer belt rotates one turn.

<b>44-4</b>	
<b>Purpose</b>	Setting
<b>Function (Purpose)</b>	Used to set the conditions of the high density process control operation.
<b>Section</b>	Process
<b>Operation/Procedure</b>	
1) Select an item to be set with scroll keys.	
2) Enter the set value with 10-key.	
3) Press [OK] key.	

**Important**

Set the items to the default values unless a change is specially required.

	Item/Display	Content	Setting range	Default value
A	PCS_CL TARGET	Color image sensor adjustment target value	1 - 255	98
B	PCS_K TARGET	Black image sensor adjustment target value	1 - 255	208
C	LED_CL OUTPUT	Color image sensor light emitting start level	1 - 255	21
D	LED_K OUTPUT	Black image sensor light emitting start level	1 - 255	21
E	PCS ADJUSTMENT LIMIT	Color image sensor adjustment error allowance level	1 - 255	4
F	BELT GROUND DIF	Transfer belt one-turn substrate detection level difference allowance level	1 - 255	1
G	BIAS_CL STANDARD DIF	Developing bias (for color) reference correction voltage	0 - 255	60
H	BIAS_BK STANDARD DIF	Developing bias (for black) reference correction voltage	0 - 255	0
I	BIAS PATCH INTERVAL	Toner patch making developing bias interval	1 - 255	60
J	Y_PAT TARGET ID	Process control target density level (yellow)	1 - 255	111
K	M_PAT TARGET ID	Process control target density level (magenta)	1 - 255	135
L	C_PAT TARGET ID	Process control target density level (cyan)	1 - 255	128
M	K_PAT TARGET ID	Process control target density level (black)	1 - 255	45
N	HV BK_GROUND LIMIT	Black image sensor adjustment error allowance level	1 - 255	60

**44-6**

<b>Purpose</b>	Adjustment
<b>Function (Purpose)</b>	Used to execute the high density process control forcibly.
<b>Section</b>	Process

**Operation/Procedure**

Press [EXECUTE] key.

In case of a normal completion, the result is saved.

In case of an abnormal completion, "ERROR" is displayed. (Refer to the table below.)

In case of an ERROR, the previous correction data are saved.

Result display	Content description
COMPLETE	Normal complete
ERROR	Abnormal end
INTERRUPTION	Forcible interruption

Details of error display	Content description
CL_SEN_ADJ_ERR	Color image sensor adjustment abnormality
BK_SEN_ADJ_ERR	Black image sensor adjustment abnormality
K_HV_ERR	K high density process control abnormality
C_HV_ERR	C high density process control abnormality
M_HV_ERR	M high density process control abnormality
Y_HV_ERR	Y high density process control abnormality
TIMEOUT_ERR	Time out

<b>Purpose</b>	Operation data display
<b>Function (Purpose)</b>	Used to display the result data of the high density process control operation.
<b>Section</b>	Image process (Photoconductor/Developing/Transfer/Cleaning)

**Operation/Procedure**

Select a target display mode with [CPY/PRN], [OTHER] keys.

Mode	Item/Display (*: Correction value)	Content	Display range	Default value	
CPY/PRN	P (PROCON)	BLACK : GB **** DV ****	High density process control mode GB/DV data (KCMY) (Output voltage level/base voltage level)	GB: 150 - 850 DV: 0 - 600	GB: 630 DV: 430
		CYAN : GB **** DV ****			
		MAGENTA : GB **** DV ****			
		YELLOW : GB **** DV ****			
	N(M) (NORMAL (MIDDLE))	BLACK : GB **** DV ****	Medium speed print mode GB/DV data (KCMY) (Actual output voltage level/base voltage level)	GB: 150 - 850 DV: 0 - 600	GB: 630 DV: 430
		CYAN : GB **** DV ****			
		MAGENTA : GB **** DV ****			
		YELLOW : GB **** DV ****			
	N(L) (NORMAL (LOW))	BLACK : GB **** DV ****	Low speed print mode GB/DV data (KCMY) (Actual output voltage level/base voltage level)	GB: 150 - 850 DV: 0 - 600	GB: 600 DV: 400
		CYAN : GB **** DV ****			
		MAGENTA : GB **** DV ****			
		YELLOW : GB **** DV ****			
OTHER	TN/TC	TN HUD AREA	Toner density correction humidity area	1 - 8	4
		TN HUD DATA	Toner density correction humidity AD value	0 - 1023	0
		TC TMP AREA	Transfer correction temperature area	1 - 9	4
		TC TMP DATA	Transfer correction temperature AD value	0 - 1023	0
		TC HUD AREA	Transfer correction humidity area	1 - 9	4
		TC HUD DATA	Transfer correction humidity AD value	0 - 1023	0
		MD HUD AREA	Membrane decrease correction humidity area	1 - 8	4
		MD HUD DATA	Membrane decrease correction humidity AD value	0 - 1023	0
	DRUM	MD K STEP	Drum membrane decrease correction STEP level (KCMY)	0 - 4	0
		MD C STEP			
		MD M STEP			
		MD Y STEP			
		MD K DRUM COUNTER	Membrane decrease drum traveling distance area (KCMY)	0 - 20	0
		MD C DRUM COUNTER			
		MD M DRUM COUNTER			
		MD Y DRUM COUNTER			
	LIFE	MD K REVISE(LIFE) : L *** M ***	MC grid correction voltage level (for the drum membrane decrease) (KCMY)	0 - 255	0
		MD C REVISE(LIFE) : L *** M ***			
		MD M REVISE(LIFE) : L *** M ***			
		MD Y REVISE(LIFE) : L *** M ***			
	EV	MD K REVISE(EV) : L *** M ***	MC grid voltage correction level (for the environment) (KCMY)	0 - 255	0
		MD C REVISE(EV) : L *** M ***			
		MD M REVISE(EV) : L *** M ***			
		MD Y REVISE(EV) : L *** M ***			
	ALL	MD K REVISE(ALL) : L *** M ***	MC grid voltage correction level (for the drum membrane decrease) (KCMY)	0 - 255	0
		MD C REVISE(ALL) : L *** M ***			
		MD M REVISE(ALL) : L *** M ***			
		MD Y REVISE(ALL) : L *** M ***			
	LD	MD K REVISE(LD) : L *** M ***	Laser power correction level (for the drum membrane decrease) (KCMY)	0 - 255	0
		MD C REVISE(LD) : L *** M ***			
		MD M REVISE(LD) : L *** M ***			
		MD Y REVISE(LD) : L *** M ***			
	DL	MD K REVISE COL (DL) : L *** M ***	Discharge lamp correction level (%) (for the drum membrane decrease)	0 - 100	70
		MD C REVISE COL (DL) : L *** M ***			
		MD M REVISE COL (DL) : L *** M ***			
		MD Y REVISE COL (DL) : L *** M ***			
	DL EV	MD K REVISE COL (DL EV) : L *** M ***	Discharge lamp correction level (%) (for the environment)	-100 - 100	0
		MD C REVISE COL (DL EV) : L *** M ***			
		MD M REVISE COL (DL EV) : L *** M ***			
		MD Y REVISE COL (DL EV) : L *** M ***			

Mode	Item/Display (*: Correction value)		Content	Display range	Default value
OTHER	CRUM	DESTINATION	CRUM destination (Main unit data)	-	-
		MODEL TYPE	Machine model type	0 - 1	0
		CRUM DEST_K	CRUM destination (CRUM data)	-	-
		CRUM DEST_C			
		CRUM DEST_M			
	CRUM DEST_Y				
	CNT	PROCON COUNT HV	High density process control number of executions	0 - 99999999	0
PROCON COUNT HT		Halfone process control number of executions	0 - 99999999	0	

44-12

**Purpose** Operation data display

**Function (Purpose)** Used to display the operation data of the high density process control and the image density sensor (registration sensor).

**Section** Image process (Photoconductor/Developing)

#### Operation/Procedure

Select a display mode with [TARGET] [PATCH] keys.

Mode	Item/Display	Content	Display range	Default value
TARGET	CARB DATA	Standard reflection plate detection level	0 - 255	108
	SEAL ADJ DATA	Jig patch seal detection level when executing SIM 44-13	1 - 255	108
	ADK_SL (K)	Development characteristics gradient coefficient (High density process control operation)	-9.99 - 9.99	0
	ADK_INT(K)	Development characteristics intercept level (High density process control operation 0V)	-999.9 - 999.9	0
	TARGET (K)	High density process control target density level (K)	0.00 - 255.00	0
	TARGET (C/M/Y)	High density process control target density level (C/M/Y)	0.00 - 255.00	0
PATCH	n-1	High density process control nth time toner patch density level 1 (n=1-5)	0 - 255	0
	n-2	Toner patch data nth time patch 2 (n=1-5)	0 - 255	0
	n-3	Toner patch data nth time patch 3 (n=1-5)	0 - 255	0
	n-4	Toner patch data nth time patch 4 (n=1-5) • BK only	0 - 255	0
	n-5	Toner patch data nth time patch 5 (n=1-5) • BK only	0 - 255	0
PATCH	n-1	Toner patch data nth time patch 1 (n=6-10)	0 - 255	0
	n-2	Toner patch data nth time patch 2 (n=6-10)	0 - 255	0
	n-3	Toner patch data nth time patch 3 (n=6-10)	0 - 255	0
	n-4	Toner patch data nth time patch 4 (n=6-10) • BK only	0 - 255	0
	n-5	Toner patch data nth time patch 5 (n=6-10) • BK only	0 - 255	0

44-13

**Purpose** Adjustment/Setup

**Function (Purpose)** Used to perform the color image sensor (image registration sensor F) calibration.

**Section**

#### Operation/Procedure

- 1) Remove the BK developing unit, the BK OPC drum unit, and the primary transfer unit. Attach the calibration jig.
- 2) Press [EXECUTE] key.  
Calibration is performed, and the data are displayed.
- 3) Install the BK developing unit, the BK OPC drum unit, and the primary transfer unit.
- 4) Press [EXECUTE] key.

	Item/Display	Content	Setting range	Default value
A	PCS_CL CARB OUT	Calibration plate sensor value	1 - 255	108
B	PCS_CL LED ADJ	Color sensor light emitting quantity adjustment value	1 - 255	21

Error display	Content
SEN ADJ ERR	Color image sensor sensitivity adjustment abnormality
SHUTTER CLOSE ERR	Primary transfer operation abnormality
ERROR	Compulsory stop

44-14

**Purpose** Operation data display

**Function (Purpose)** Used to display the output level of the temperature and humidity sensor.

**Section** Process (OPC drum, development)/Fusing/LSU

#### Operation/Procedure

The output levels of the fusing temperature sensor, the machine temperature sensor, and the humidity sensor are displayed.

Item/Display	Content	Display range
TH_UM	Fusing main thermistor differential input level (°C) / (AD value)	Temperature: 0 - 255°C (±1°C) AD value: 0-1023
TH_UM_AD1	Fusing thermistor detection level for compensation (°C) / (AD value)	Temperature: 0.0-255.0°C (±0.2°C) AD value: 0-1023
TH_UM_AD2	Fusing thermistor detection level (AD value)	AD value: 0-1023
TH_LM	Fusing thermistor A/D value (temperature °C) (Fusing roller B edge)	Temperature: 0 - 255°C (±1°C) AD value: 0-1023
TH_US	Fusing sub thermistor A/D value (temperature °C) (Fusing belt)	Temperature: 0 - 255°C (±1°C) AD value: 0-1023
TEMPRATURE	Process control thermistor detection level	Temperature: -40.0 - 60.0°C (±0.1°C) AD value: 0-1023

Item/Display	Content	Display range
HUMIDITY	Process control humidity sensor detection level	Humidity: 5.0-90.0% ( $\pm 0.1\%$ ), AD value: 0-1023
TH1_LSU	LSU thermistor detection level (A/D value) ( $^{\circ}\text{C}$ )	Temperature: 5.0-60.0 $^{\circ}\text{C}$ ( $\pm 0.1^{\circ}\text{C}$ ) AD value: 0-255

44-15

<b>Purpose</b>	Setting
<b>Function (Purpose)</b>	Used to set the OPC drum idle rotation.
<b>Section</b>	Process

#### Operation/Procedure

- 1) Select an item to be set with the scroll key.
- 2) Enter the set value with 10-key.
- 3) Press [OK] key.

The initial value must be set unless any special change is required.

Item/Display	Content	Setting range	Default value
A TIME	Idle rotation interval (time interval between the previous OPC drum idle rotation and the next one) setting (h)	0 - 255	6
B AREA1	Environmental area difference judgment threshold value setting (difference between the previous OPC drum idle rotation and the current one)	0 - 5	2
C AREA2	Environmental area conditions (AND condition of the previous OPC drum idle rotation and the current one)	1 - 15	1
D CYCLE	Previous rotation time setting (sec) in the process control when recovered from power ON, preheating/sleep mode.	0 - 255	0

The execution YES/NO of the OPC drum idle rotation is determined by the AND condition of TIME, AREA1, and AREA 2.

To execute the OPC drum idle rotation, set item B (AREA 1) to "0," and item C (AREA2) to "15."

However, idle rotation is performed in a certain interval while in shut off. This must be fully explained to the user.

44-21

<b>Purpose</b>	Adjustment/Setup
<b>Function (Purpose)</b>	Used to set the halftone process control target.
<b>Section</b>	Process

#### Operation/Procedure

Press [EXECUTE] key.

The halftone process control target is set and the operation data are displayed.

Display	Content
COMPLETE	Normal complete
ERROR COLOR SENSOR ADJUSTMENT	Color image density sensor sensitivity adjustment error
ERROR BLACK SENSOR ADJUSTMENT	Black image density sensor sensitivity adjustment error
[YMCK]	High density process control error [YMCK]
OTHER	Other errors

44-22

<b>Purpose</b>	Operation data display
<b>Function (Purpose)</b>	Used to display the toner patch density level in the halftone process control operation.
<b>Section</b>	Process

#### Operation/Procedure

- 1) Select the display mode with [1ST STEP],[2ND STEP] key.  
The toner patch density level made in the halftone process control operation is displayed.

Item/Display	Content
ID_n	Patch data display (PTK: n = 1 - 24, PTC/PTM/PTY: n = 1 - 16)
BASE1	Belt substrate data (START)
BASE5	Belt substrate data (LAST)

44-24

<b>Purpose</b>	Operation data display
<b>Function (Purpose)</b>	Used to display the correction target and the correction level in the halftone process control operation.
<b>Section</b>	Process

#### Operation/Procedure

- 1) Select the display category with [NEXT] key.
- 2) Select a target adjustment color with [K] [C] [M] [Y] key.

Category	Item/Display	Content
Coefficient	[EX-LOW]	Coefficient of the approximation formula of the minimum density
	[LOW]	Coefficient of the approximation formula of the low density
	[CONNECT]	Coefficient of the approximation formula of when connecting the low density and the medium density
	[MID]	Coefficient of the approximation formula of the medium density
	[HIGH]	Coefficient of the approximation formula of the high density
	[CONNECT POINT]	Each density section connection output ratio
Reference value	[SENSOR_TARGET]	Halftone process control reference value
Correction value	[S_VALUE]	Halftone process control correction value
For printer	[PRINTER_S_VALUE]	Printer halftone process control correction value
	[PRINTER_BASE_DITHER_VALUE]	Printer halftone process control reference dither value
	[PRINTER_AUTO_HT_VALUE]	Printer auto density adjustment correction value
Previous correction value	[BEFORE S_VALUE]	Previous halftone process control value

44-25

<b>Purpose</b>	Setting
<b>Function (Purpose)</b>	Used to set the calculating conditions of the correction value for the halftone process control.
<b>Section</b>	Process

**Operation/Procedure**

- 1) Select a target adjustment color with [K] [C] [M] [Y] key.
- 2) Select a target adjustment density level with scroll key on the touch panel.
- 3) Enter the set value with 10-key.
- 4) Press [OK] key.

**Important**

Set the items to the default values unless a change is specially required.

Item/Display	Content	Setting range	Default value	
			K	CMY
A LOW FIELD LOWER LIMIT	Low density approximate expression data lower limit value	0 - 255	98	2
B LOW FIELD UPPER LIMIT	Low density approximate expression data upper limit value	0 - 255	60	40
C MID FIELD LOWER LIMIT	Medium density approximate expression data lower limit value	0 - 255	90	15
D MID FIELD UPPER LIMIT	Medium density approximate expression data upper limit value	0 - 255	6	144
E HIGHLIGHT POINT	Reference point of the highlight correction amount	1 - 8	7	7
F HIGHLIGHT VALUE LIMIT	Highlight correction amount limit value	0 - 128	20	20
G MAX VALUE LIMIT	Maximum density value correction limit value	0 - 128	20	20

44-26

<b>Purpose</b>	Adjustment/Setup
<b>Function (Purpose)</b>	Used to execute the halftone process control compulsory.
<b>Section</b>	Process

**Operation/Procedure**

Press [EXECUTE] key.

The halftone process control is performed and the operation data are displayed.

COMPLETE	Normal complete
ERROR COLOR SENSOR ADJUSTMENT	Color image density sensor sensitivity adjustment error
ERROR BLACK SENSOR ADJUSTMENT	Black image density sensor sensitivity adjustment error
[YMCK]	High density process control error [YMCK] error
OTHER	Other errors

44-27

<b>Purpose</b>	Data clear
<b>Function (Purpose)</b>	Used to clear the correction data of the halftone process control.
<b>Section</b>	Process

**Operation/Procedure**

- 1) Press [EXECUTE] key.
  - 2) Press [YES] key.
- The correction data of the halftone process control are cleared.

44-28

<b>Purpose</b>	Adjustment/Setup
<b>Function (Purpose)</b>	Used to set the process control execution conditions.
<b>Section</b>	Process

**Operation/Procedure**

- 1) Select a target item of setting with scroll key on the touch panel.
- 2) Enter the set value with 10-key.
- 3) Press [OK] key. (The set value is saved.)

**Important**

Set the items to the default values unless a change is specially required.



Mode	Item/Display		Content	Setting range	Default value			
Process control Enable/Disable setting	A	INITIAL	YES	When warm-up after clearing the counter of the OPC drum and the developer unit	Enable	0 - 1	0	0
			NO		Disable		1	
	B	SW ON		When supplying the power (when canceling power shut-off)	Color process control Enable	0 - 3	0	3
					Process control Disable		1	
					BK process control Enable		2	
					Pixel count judgment		3	
	C	TIME		After passing the specified time from leaving READY continuously (Time can be changed by INTERVAL TIME)	Color process control Enable	0 - 3	0	3
					Process control Disable		1	
					BK process control Enable		2	
					Pixel count judgment		3	
	D	HUM_LIMIT		HUM judgment is made when turning ON the power and after passing INTERVAL TIME.	Color process control Enable	0 - 2	0	0
					Process control Disable		1	
					BK process control Enable		2	
	E	HUM		The temperature and humidity inside the machine are monitored only during a job at the interval set by the item of HUM HOUR. When the changes in the temperature and the humidity are greater than the specified level (the set value of item HUM DIF) in comparison with the previous process control.	Color process control Enable	0 - 2	0	0
Process control Disable					1			
BK process control Enable					2			
F	REV1	YES	When the accumulated traveling distance of K or M OPC drum unit reaches the specified level after turning ON the power.	Enable	0 - 1	0	0	
		NO		Inhibit		1		
G	REV2_BK	YES	When the accumulated traveling distance of K OPC drum unit reaches the specified level from execution of the previous density correction.	Enable	0 - 1	0	0	
		NO		Inhibit		1		
H	REV2_CL	YES	When the accumulated traveling distance of M OPC drum unit reaches the specified level from execution of the previous density correction.	Enable	0 - 1	0	0	
		NO		Inhibit		1		
I	REFRESH MODE	YES	Select of YES/NO of the manual process control key with key operation	Key operation display	0 - 1	0	1	
		NO		Key operation NO display		1		
Setting of the execution conditions of the process control	J	DAY	When there is no color job from when the previous color process control was performed to when the number of days set by this item setting, perform the process control when executing the next warming up.	0: Disable of the specified days judgment	0 - 999	0	1	
				1 - 999: 1 - 999 days passing		999		
	K	HI-COV		Setting of the execution conditions of the process control for the print ratio	The process control is performed by considering the average print ratio of every 10 pages as the judgment criteria.	0 - 2	0	0
Print ratio judgment inhibit (The process control for the target of print ratio is not performed.)					1			
The process control is performed by considering the average print ratio of 30 pages as the judgment criteria in a continuous print job of 30 or more pages.					2			

Mode	Item/Display		Content	Setting range	Default value		
Setting of the execution conditions of the process control	L	LO-COV	Setting of the execution judgment of the process control in continuous printing of low print ratio images	Enable	0 - 1	0	
				Inhibit			1
	M	TonerCA-END	Setting of the process control interval reduction when the toner cartridge remaining quantity is 25% or less (If this is set to Enable, item M RATIO is changed.)	Enable	0 - 1	0	
				Inhibit			1
	N	AVERAGE-PAGE	Setting of the number of pages of item HI-COV set value 2	1: 10 pages - 5: 50 pages 1 step corresponds to 10 pages.	1 - 5	1 5	3
	O	LIMIT PAGE	Setting of the number of connected jobs of the process control and of the limit number of the process control A number of reservation jobs are connected. When the number of jobs exceeds the specified number of pages (the set value of this setting), the process control is performed. / The process control is performed by AND conditions of item REV condition and the specified number of pages (the set value of this setting).	1: 10 pages - 10: 100 pages 1 step corresponds to 10 pages.	1 - 10	1	10
						10	
	P	PIX_RATIO_BK	Magnification ratio setting (%) of the BK toner count specified value The set value of 100 corresponds to K print of A4 at the print ratio of 5%.		1 - 999		10
	Q	PIX_RATIO_CL	Magnification ratio setting (%) of the color (CMY) toner count specified value The set value of 100 corresponds to K print of A4 at the print ratio of 5%.		1 - 999		10
	R	INTERVAL TIME	Setting of the leaving time when turning ON the power (including the sleep recovery time) (h: hour)		1 - 255		3
	S	HUM HOUR	Interval setting of the temperature and humidity monitoring time of "HUM" (unit: 10 minutes)		1 - 24		2
	T	HUM_DIF	The specified value of the area difference in humidity between the level at execution of the previous control and the current humidity (Applied to item HUM)		1 - 9		2
	U	BK_RATIO	Magnification ratio setting (%) of the specified value of the BK OPC drum traveling distance of "REV2_BK"		1 - 999 (Entry of 20 corresponds to 100,000mm.)		15
	V	M_RATIO	Magnification ratio setting (%) of the M OPC drum traveling distance of "REV2_CL"		1 - 999 (Entry of 20 corresponds to 100,000mm.)		15
W	COLOR BORDER	Judgment criteria whether the BK high density process control is individually performed or not (Setting of the ratio of the M OPC drum rotation distance for the K OPC drum rotation distance (%))	0: The BK process control is executed regardless of the M OPC drum traveling distance.	0 - 999		20	
			1 - 999: 1 - 999(%)				
X	BK ONLY	Setting of the frequency of execution of the 4-color high density process control when only monochrome output is continued (The result of this setting is applied only when the M OPC drum rotation distance is smaller than the set value of COLOR BORDER.)	Frequency of once for 5 times	0 - 6	0	5	
			Frequency of once for 1 - 5 times		1 - 5		
			The 4-color high density process control is always performed.		6		
Y	HT_DIF	HT process control execution judgment developing bias variation value		1 - 255		40	
Setting of the execution condition of the registration adjustment	Z	RG_ON_SYNC	CL	Setting of execution of the registration adjustment when executing the process control when turning ON the power	When the color process control is executed.	0	0
			ALL		Executed regardless of the process control.	1	
			CL/BK		When the color process control and the K process control are executed.	2	
	AA	RG_TEMP_TIMER	Time interval from registration adjustment after turning ON the power to the next execution.		0 - 240 (MINUTE)		0
	AB	RG_PERM_TIMER	Setting of inhibit time of execution of the registration adjustment		0 - 15 (HOUR)		1
	AC	RG_HOUR_TIMER	Setting of the interval time of execution of the registration adjustment		0 - 15 (Above)+ (HOUR)		5
	AD	RG_BW_SYNC	Setting of Enable/Disable of the registration adjustment after a monochrome job	Enable	0 - 1	0	1
				Inhibit		1	

Mode	Item/Display	Content	Setting range	Default value	
Setting of the secondary transfer cleaning conditions	AE	2TRAN_CLEAN_TIME1	Secondary transfer cleaning process time judgment threshold value 1 (The total number of sheets for cleaning execution conditions) (Cleaning time: Short)	5 - 999	200
	AF	2TRAN_CLEAN_TIME2	Secondary transfer cleaning process time judgment threshold value 2 (The total number of sheets for cleaning execution conditions) (Cleaning time: Medium)	5 - 999	300
	AG	2TRAN_CLEAN_TIME3	Secondary transfer cleaning process time judgment threshold value 3 (The total number of sheets for cleaning execution conditions) (Cleaning time: Long)	5 - 999	500

When REFRESH MODE setting is enabled (0), the menu of the user process control execution button is displayed on the user system setting menu.

When the color balance or the density change is not within the allowable range, the user can perform the process control manually and forcibly. However, toner is consumed greater than as usual. This point must be explained to the user clearly.

<b>44-29</b>	
<b>Purpose</b>	Setting
<b>Function (Purpose)</b>	Used to set the operating conditions of the process control during a job.
<b>Section</b>	Process

#### Operation/Procedure

- 1) Select a target item of setting with scroll key on the touch panel.
- 2) Enter the set value with 10-key.
- 3) Press [OK] key.

Item/Display	Content	Setting range	Default value
A COPY	During copy job	0 - 2 0: No execution 1: HV only 2: HV → HT	2
B PRINTER	During print job		2
C FAX	During FAX print job		2
D SELF PRINT	During self print		2
E CPY TO PRT TABLE	Half-tone process control copier - printer conversion table select	0 - 1 0: CALCULATED 1: DEFAULT	0 0: Color balance calculation value (Revised every time when SIM46-74 is executed.) 1: Default (Fixed value)

HV: High density process control

HT: Half-tone process control

<b>44-31</b>	
<b>Purpose</b>	Adjustment/Setup
<b>Function (Purpose)</b>	Used to adjust the OPC drum phase. (Manual adjustment)
<b>Section</b>	Process

#### Operation/Procedure



For the OPC drum phase adjustment, do not use this simulation, but use SIM50-22 (auto adjustment).

- 1) Select item A with scroll key.
- 2) Enter the value corresponding to the adjustment pattern with 10-key.
- 3) Press [EXECUTE] key. (The adjustment pattern is printed out.)
- 4) Select an adjustment pattern whose deflection is within two scale lines on the adjustment pattern of C, M, Y colors.
- 5) Select item B with scroll key.
- 6) Enter the adjustment pattern sheet number selected in procedure 4).
- 7) Press [EXECUTE] key.
- 8) The adjusted adjustment pattern is printed.

<b>44-37</b>	
<b>Purpose</b>	Adjustment/Setup
<b>Function (Purpose)</b>	Used to set the development bias correction level in the continuous printing operation.
<b>Section</b>	

#### Operation/Procedure

- 1) Select a set target color with the touch panel.
- 2) Select a target item with scroll keys.
- 3) Enter the set value with 10-key.
- 4) Press [OK] key. (The set value is saved.)

#### Note

When the print density is varied in the continuous printing operation, this simulation is used.

		Item/Display		Default value		Variable range	
		Black	CMY	Black	CMY		
Current DV Bias voltage	Low speed mode Heavy paper mode	less than 300 [v]	A	A	0	0	0-5 (*1)
		300 [v] or more, less than 450 [v] 450 [v] or more	B	B	0	0	
	Middle speed mode	less than 300 [v]	C	C	0	0	
		300 [v] or more, less than 450 [v]	D	D	0	0	
		450 [v] or more	E	E	0	0	
	High speed mode Monochrome mode	less than 300 [v]	F	F	0	0	
		300 [v] or more, less than 450 [v]	G	-	0	-	
		450 [v] or more	H	-	0	-	
	Time (T) from termination of continuous outputs to start of the next output operation	Low speed mode Heavy paper mode	Less than 10 [sec] & after process control JOB	I	-	0	
10 [sec] or more, less than 60 [sec]			J	G	4	4	
60 [sec] or more, less than 240 [sec]			K	H	3	3	
240 [sec] or more			L	I	1	1	
Middle speed mode		Less than 10 [sec] & after process control JOB	M	J	1	1	
		10 [sec] or more, less than 60 [sec]	N	K	4	4	
		60 [sec] or more, less than 240 [sec]	O	L	3	3	
		240 [sec] or more	P	M	1	1	
High speed mode Monochrome mode		Less than 10 [sec] & after process control JOB	Q	N	1	1	
		10 [sec] or more, less than 60 [sec]	R	-	4	-	
		60 [sec] or more, less than 240 [sec]	S	-	3	-	
		240 [sec] or more	T	-	1	-	
		U	-	1	-		

<Use example>

(\*1)

Make multi copy of 10 sheets. If the density of 10th sheet is greater than that of the first sheet, decrease the set value.

Make multi copy of 10 sheets. If the density of 10th sheet is smaller than that of the first sheet, increase the set value.

When the set value is 0 (Default), the correction level does not work.

44-43

<b>Purpose</b>	Data display
<b>Function (Purpose)</b>	Used to display the identification information of the developing unit.
<b>Section</b>	Developing system

#### Operation/Procedure

The identification number and the identification signal level of the developing unit are displayed.

Item/Display	Content	Display range	NOTE
A	DVCH KIND K	K developing unit identification number	The model identification number of the developing unit which is backed up in the EEPROM of the machine.
B	DVCH KIND C	C developing unit identification number	
C	DVCH KIND M	M developing unit identification number	
D	DVCH KIND Y	Y developing unit identification number	
E	DV_TYP_SEL_K	K developing unit identification detection	0 = High (Open) 1 = Low (GND)
F	DV_TYP_SEL_C	C developing unit identification detection	
G	DV_TYP_SEL_M	M developing unit identification detection	
H	DV_TYP_SEL_Y	Y developing unit identification detection	
I	DVCH_AD_K	K developing unit identification AD value	AD value of the developing unit identification voltage
J	DVCH_AD_C	C developing unit identification AD value	
K	DVCH_AD_M	M developing unit identification AD value	
L	DVCH_AD_Y	Y developing unit identification AD value	

\* The developing unit is identified by the combination of items E, F, G, H and items I, J, K, and L.

**44-61**

**Purpose** Adjustment

**Function (Purpose)** Used to adjust the color image density sensor. (The adjustment is made according to the input of SIM44-13 to set the target value of the color sensor gain adjustment.)

**Section**

**Operation/Procedure**

- 1) Select an adjustment target item with scroll key.
- 2) Enter the set value with 10-key.
- 3) Press [OK] key. (The set value is saved.)

Item/Display	Content	Setting range	Default value
A PCS_CL CARB OUT	Calibration plate sensor value	1 - 255	108
B PCS_CL LED ADJ	Color sensor light emitting quantity adjustment value	1 - 255	21

**44-62**

**Purpose** Setup/Adjustment

**Function (Purpose)** Used to set the process control execution conditions.

**Section** Process

**Operation/Procedure**

This simulation allows collective change in the set contents of SIM44-4 and SIM44-28.

A suitable one is selected among a number of options depending on the condition.

- 1) Select an item to be set.  
 To change the image density in the high density area, select PROCON TARGET.  
 To change the frequency of the process control operations, select PROCON MODE.

Display/Item	Content
PROCON TARGET	CL ID DOWN The densities of C, M, and Y decrease. (The C/M/Y high density process control target values decrease.)
	CL ID UP The densities of C, M, and Y increase. (The C/M/Y high density process control target values increase.)
	BK ID DOWN The density of K decreases. (The high density process control target value decreases.)
	BK ID UP The density of K increases. (The high density process control target value increases.)
	ALL ID DOWN The densities of C, M, Y and K decrease. (The C/M/Y/K high density process control target values decrease.)
	ALL ID UP The densities of C, M, Y and K increase. (The C/M/Y/K high density process control target values increase.)
	NORMAL The standard density of C, M, Y and K. (The C/M/Y/K high density process control target values are the standard values.)

Display/Item	Content
PROCON MODE	HIGH QUALITY1 The execution frequency of the process control is high. (It is set when the color image quality is given priority.)
	HIGH QUALITY2 The execution frequency of the process control is highest. (It is set when the color image quality is given priority.)
	PRINT PERFORMANCE The execution frequency of the process control is low. (It is set when the job speed is given priority.)
	BW MODE The process control is executed in the normal frequency. (It is set when there are little color jobs and many monochrome jobs.)
	NORMAL The process control is executed in the normal frequency.

(When PROCON TARGET is selected.)

- 2A) Select the density level.

(When PROCON MODE is selected.)

- 2B) Select the execution frequency of the process control.
- 3) Press [EXECUTE] key.
- 4) Press [YES] key.

**Note**

This simulation may not function with some firmware versions. In such a case, the firmware must be upgraded to the latest version.

**46**

**46-1**

**Purpose** Adjustment (Color copy mode)

**Function (Purpose)** Used to adjust the copy density in the copy mode.

**Section**

**Operation/Procedure**

- 1) Select an adjustment target item with scroll key on the touch panel.
- 2) Enter the set value with 10-key.  
 \* When the  $\Delta$   $\nabla$  key is pressed, the setting value of each item can be changed with 1up (1down) collectively.
- 3) Press [OK] key. (The set value is saved.)

To adjust the copy density in the low density area, select the "LOW" mode and change the adjustment value. To adjust the copy density in the high density area, select the "HIGH" mode and change the adjustment value.

When the adjustment value is increased, the copy density is increased. When the adjustment value is decreased, the copy density is decreased.

**18cpm/20cpm/23cpm/31cpm(G) machine**

Item/Display	Content	Setting range	Default value	
A AUTO	Auto	LOW	1 - 99	50
		HIGH	1 - 99	50
B TEXT	Text	LOW	1 - 99	50
		HIGH	1 - 99	50
C TEXT/PRINTED PHOTO	Text/Printed Photo	LOW	1 - 99	50
		HIGH	1 - 99	50
D TEXT/PHOTO	Text/Photograph	LOW	1 - 99	50
		HIGH	1 - 99	50
E PRINTED PHOTO	Printed Photo	LOW	1 - 99	50
		HIGH	1 - 99	50
F PHOTOGRAPH	Photograph	LOW	1 - 99	50
		HIGH	1 - 99	50

Item/Display	Content	Setting range	Default value
G	MAP	Map	LOW 1 - 99 50
			HIGH 1 - 99 50
H	LIGHT	Light document	LOW 1 - 99 50
			HIGH 1 - 99 50
I	TEXT(COPY TO COPY)	Text (Copy document)	LOW 1 - 99 50
			HIGH 1 - 99 50
J	TEXT/PRINTED PHOTO (COPY TO COPY)	Text/Printed Photo (Copy document)	LOW 1 - 99 50
			HIGH 1 - 99 50
K	PRINTED PHOTO (COPY TO COPY)	Printed Photo (Copy document)	LOW 1 - 99 50
			HIGH 1 - 99 50
L	TEXT (COLOR TONE ENHANCEMENT)	Text (Color tone enhancement)	LOW 1 - 99 50
			HIGH 1 - 99 50
M	TEXT/PRINTED PHOTO (COLOR TONE ENHANCEMENT)	Text/Printed Photo (Color tone enhancement)	LOW 1 - 99 50
			HIGH 1 - 99 50
N	TEXT/PHOTO (COLOR TONE ENHANCEMENT)	Text/Photograph (Color tone enhancement)	LOW 1 - 99 50
			HIGH 1 - 99 50
O	PRINTED PHOTO (COLOR TONE ENHANCEMENT)	Printed Photo (Color tone enhancement)	LOW 1 - 99 50
			HIGH 1 - 99 50
P	PHOTOGRAPH (COLOR TONE ENHANCEMENT)	Photograph (Color tone enhancement)	LOW 1 - 99 50
			HIGH 1 - 99 50
Q	MAP (COLOR TONE ENHANCEMENT)	Map (Color tone enhancement)	LOW 1 - 99 50
			HIGH 1 - 99 50
R	SINGLE COLOR	Single color	LOW 1 - 99 50
			HIGH 1 - 99 50
S	SINGLE COLOR (COPY TO COPY)	Single color (Copy document)	LOW 1 - 99 50
			HIGH 1 - 99 50
T	TWO COLOR	2-color (red/black) copy	LOW 1 - 99 50
			HIGH 1 - 99 50
U	TWO COLOR (COPY TO COPY)	2-color (red/black) copy (copy document)	LOW 1 - 99 50
			HIGH 1 - 99 50

### 26cpm/36cpm/31cpm(A) machine

Item/Display	Content	Setting range	Default value
A	AUTO	Auto	LOW 1 - 99 50
			HIGH 1 - 99 50
B	TEXT	Text	LOW 1 - 99 50
			HIGH 1 - 99 50
C	TEXT/PRINTED PHOTO	Text/Printed Photo	LOW 1 - 99 50
			HIGH 1 - 99 50
D	TEXT/PHOTO	Text/Photograph	LOW 1 - 99 50
			HIGH 1 - 99 50
E	PRINTED PHOTO	Printed Photo	LOW 1 - 99 50
			HIGH 1 - 99 50
F	PHOTOGRAPH	Photograph	LOW 1 - 99 50
			HIGH 1 - 99 50
G	MAP	Map	LOW 1 - 99 50
			HIGH 1 - 99 50
H	LIGHT	Light document	LOW 1 - 99 50
			HIGH 1 - 99 50
I	TEXT(COPY TO COPY)	Text (Copy document)	LOW 1 - 99 50
			HIGH 1 - 99 50
J	TEXT/PRINTED PHOTO (COPY TO COPY)	Text/Printed Photo (Copy document)	LOW 1 - 99 50
			HIGH 1 - 99 50
K	PRINTED PHOTO (COPY TO COPY)	Printed Photo (Copy document)	LOW 1 - 99 50
			HIGH 1 - 99 50
L	TEXT (COLOR TONE ENHANCEMENT)	Text (Color tone enhancement)	LOW 1 - 99 50
			HIGH 1 - 99 50

Item/Display	Content	Setting range	Default value
M	TEXT/PRINTED PHOTO (COLOR TONE ENHANCEMENT)	Text/Printed Photo (Color tone enhancement)	LOW 1 - 99 50
			HIGH 1 - 99 50
N	TEXT/PHOTO (COLOR TONE ENHANCEMENT)	Text/Photograph (Color tone enhancement)	LOW 1 - 99 50
			HIGH 1 - 99 50
O	PRINTED PHOTO (COLOR TONE ENHANCEMENT)	Printed Photo (Color tone enhancement)	LOW 1 - 99 50
			HIGH 1 - 99 50
P	PHOTOGRAPH (COLOR TONE ENHANCEMENT)	Photograph (Color tone enhancement)	LOW 1 - 99 50
			HIGH 1 - 99 50
Q	MAP (COLOR TONE ENHANCEMENT)	Map (Color tone enhancement)	LOW 1 - 99 50
			HIGH 1 - 99 50
R	LIGHT (COLOR TONE ENHANCEMENT)	Light document (Color tone enhancement)	LOW 1 - 99 50
			HIGH 1 - 99 50
S	SINGLE COLOR	Single color	LOW 1 - 99 50
			HIGH 1 - 99 50
T	SINGLE COLOR (COPY TO COPY)	Single color (Copy document)	LOW 1 - 99 50
			HIGH 1 - 99 50
U	TWO COLOR	2-color (red/black) copy	LOW 1 - 99 50
			HIGH 1 - 99 50
V	TWO COLOR (COPY TO COPY)	2-color (red/black) copy (copy document)	LOW 1 - 99 50
			HIGH 1 - 99 50

46-2

**Purpose**

Adjustment (Monochrome copy mode)

**Function (Purpose)**

Used to adjust the copy density in the copy mode.

**Section**

### Operation/Procedure

- 1) Select an adjustment target item with scroll key on the touch panel.
- 2) Enter the set value with 10-key.
  - \* When the  $\Delta$   $\nabla$  key is pressed, the setting value of each item can be changed with 1up (1down) collectively.
- 3) Press [OK] key. (The set value is saved.)

To adjust the copy density in the low density area, select the "LOW" mode and change the adjustment value. To adjust the copy density in the high density area, select the "HIGH" mode and change the adjustment value.

When the adjustment value is increased, the copy density is increased. When the adjustment value is decreased, the copy density is decreased.

Item/Display	Content	Setting range	Default value
A	AUTO1	Auto 1	LOW 1 - 99 50
			HIGH 1 - 99 50
B	AUTO2	Auto 2	LOW 1 - 99 50
			HIGH 1 - 99 50
C	TEXT	Text	LOW 1 - 99 50
			HIGH 1 - 99 50
D	TEXT/PRINTED PHOTO	Text/Printed Photo	LOW 1 - 99 50
			HIGH 1 - 99 50
E	TEXT/PHOTO	Text/Photograph	LOW 1 - 99 50
			HIGH 1 - 99 50
F	PRINTED PHOTO	Printed Photo	LOW 1 - 99 50
			HIGH 1 - 99 50
G	PHOTOGRAPH	Photograph	LOW 1 - 99 50
			HIGH 1 - 99 50
H	MAP	Map	LOW 1 - 99 50
			HIGH 1 - 99 50

Item/Display		Content	Setting range	Default value	
I	TEXT (COPY TO COPY)	Text (Copy document)	LOW	1 - 99	50
			HIGH	1 - 99	50
J	TEXT/PRINTED PHOTO (COPY TO COPY)	Text/Printed Photo (Copy document)	LOW	1 - 99	50
			HIGH	1 - 99	50
K	PRINTED PHOTO (COPY TO COPY)	Printed Photo (Copy document)	LOW	1 - 99	50
			HIGH	1 - 99	50
L	LIGHT	Light document	LOW	1 - 99	50
			HIGH	1 - 99	50

46-4

<b>Purpose</b>	Adjustment (Color scanner mode)
<b>Function (Purpose)</b>	Used to adjust the density in the image send mode.

**Section****Operation/Procedure**

- 1) Select an adjustment target item with scroll key on the touch panel.
- 2) Enter the set value with 10-key.
  - \* When the  $\Delta$   $\nabla$  key is pressed, the setting value of each item can be changed with 1up (1down) collectively.
- 3) Press [OK] key. (The set value is saved.)

When the adjustment value is increased, the image density is increased, and vice versa.

**18cpm/20cpm/23cpm/31cpm(G) machine**

Mode	Item/Display	Content	Setting range	Default value	
LOW	A	AUTO	Auto	1 - 99	50
	B	TEXT	Text	1 - 99	50
	C	TEXT/PRINTED PHOTO	Text/Printed Photo	1 - 99	50
	D	TEXT/PHOTO	Text/Photograph	1 - 99	50
	E	PRINTED PHOTO	Printed Photo	1 - 99	50
	F	PHOTOGRAPH	Photograph	1 - 99	50
	G	MAP	Map	1 - 99	50
HIGH	A	AUTO	Auto	1 - 99	50
	B	TEXT	Text	1 - 99	50
	C	TEXT/PRINTED PHOTO	Text/Printed Photo	1 - 99	50
	D	TEXT/PHOTO	Text/Photograph	1 - 99	50
	E	PRINTED PHOTO	Printed Photo	1 - 99	50
	F	PHOTOGRAPH	Photograph	1 - 99	50
	G	MAP	Map	1 - 99	50

**26cpm/36cpm/31cpm(A) machine**

Mode	Item/Display	Content	Setting range	Default value	
LOW	A	AUTO	Auto	1 - 99	50
	B	TEXT	Text	1 - 99	50
	C	TEXT/PRINTED PHOTO	Text/Printed Photo	1 - 99	50
	D	TEXT/PHOTO	Text/Photograph	1 - 99	50
	E	PRINTED PHOTO	Printed Photo	1 - 99	50
	F	PHOTOGRAPH	Photograph	1 - 99	50
	G	MAP	Map	1 - 99	50
	H	RIP	–	1 - 99	50
HIGH	A	AUTO	Auto	1 - 99	50
	B	TEXT	Text	1 - 99	50
	C	TEXT/PRINTED PHOTO	Text/Printed Photo	1 - 99	50
	D	TEXT/PHOTO	Text/Photograph	1 - 99	50
	E	PRINTED PHOTO	Printed Photo	1 - 99	50
	F	PHOTOGRAPH	Photograph	1 - 99	50
	G	MAP	Map	1 - 99	50
	H	RIP	–	1 - 99	50

46-5

<b>Purpose</b>	Adjustment (Monochrome scanner mode)
<b>Function (Purpose)</b>	Used to adjust the density in the image send mode.

**Section****Operation/Procedure**

- 1) Select an adjustment target item with scroll key on the touch panel.
- 2) Enter the set value with 10-key.
  - \* When the  $\Delta$   $\nabla$  key is pressed, the setting value of each item can be changed with 1up (1down) collectively.
- 3) Press [OK] key. (The set value is saved.)

When the adjustment value is increased, the image density is increased, and vice versa.

**18cpm/20cpm/23cpm/31cpm(G) machine**

Mode	Item/Display	Content	Setting range	Default value	
LOW	A	AUTO	Auto	1 - 99	50
	B	TEXT	Text	1 - 99	50
	C	TEXT/PRINTED PHOTO	Text/Printed Photo	1 - 99	50
	D	TEXT/PHOTO	Text/Photograph	1 - 99	50
	E	PRINTED PHOTO	Printed Photo	1 - 99	50
	F	PHOTOGRAPH	Photograph	1 - 99	50
	G	MAP	Map	1 - 99	50
HIGH	A	AUTO	Auto	1 - 99	50
	B	TEXT	Text	1 - 99	50
	C	TEXT/PRINTED PHOTO	Text/Printed Photo	1 - 99	50
	D	TEXT/PHOTO	Text/Photograph	1 - 99	50
	E	PRINTED PHOTO	Printed Photo	1 - 99	50
	F	PHOTOGRAPH	Photograph	1 - 99	50
	G	MAP	Map	1 - 99	50

**26cpm/36cpm/31cpm(A) machine**

Mode	Item/Display	Content	Setting range	Default value	
LOW	A	AUTO	Auto	1 - 99	50
	B	TEXT	Text	1 - 99	50
	C	TEXT/PRINTED PHOTO	Text/Printed Photo	1 - 99	50
	D	TEXT/PHOTO	Text/Photograph	1 - 99	50
	E	PRINTED PHOTO	Printed Photo	1 - 99	50
	F	PHOTOGRAPH	Photograph	1 - 99	50
	G	MAP	Map	1 - 99	50
	H	RIP	–	1 - 99	50
HIGH	A	AUTO	Auto	1 - 99	50
	B	TEXT	Text	1 - 99	50
	C	TEXT/PRINTED PHOTO	Text/Printed Photo	1 - 99	50
	D	TEXT/PHOTO	Text/Photograph	1 - 99	50
	E	PRINTED PHOTO	Printed Photo	1 - 99	50
	F	PHOTOGRAPH	Photograph	1 - 99	50
	G	MAP	Map	1 - 99	50
	H	RIP	–	1 - 99	50

46-8

<b>Purpose</b>	Adjustment (Color scanner mode)
<b>Function (Purpose)</b>	Used to adjust the image send mode color balance RGB.

**Section****Operation/Procedure**

- 1) Select an adjustment target with [R] [G] [B] keys on the touch panel.
- 2) Select an adjustment target item with scroll key on the touch panel.
- 3) Enter the set value with 10-key.
- 4) Press [OK] key. (The set value is saved.)

The color balance can be adjusted separately for the low density area and the high density area.

When the adjustment value is increased, the image density of the target color is increased, and vice versa.

Item/Display	Content	Default value
A LOW DENSITY POINT	Low density correction amount	50
B HIGH DENSITY POINT	High density correction amount	50

46-9

<b>Purpose</b>	Adjustment (RSPF mode)
<b>Function (Purpose)</b>	Used to adjust the scan image density.

**Section****Operation/Procedure**

- 1) Select an adjustment target item with scroll key on the touch panel.
- 2) Enter the set value with 10-key.
  - \* When the  $\Delta$   $\nabla$  key is pressed, the setting value of each item can be changed with 1up (1down) collectively.
- 3) Press [OK] key. (The set value is saved.)

This adjustment result affects the image send mode, the copy mode, and the fax mode.

When the adjustment value is increased, the image density is increased, and vice versa.

**[RSPF]**

Item/Display	Content	Setting range	Default value
A COPY : LOW	RSPF copy mode exposure adjustment (Low density side)	1 - 99	48
B SCAN : LOW	RSPF scanner mode exposure adjustment (Low density side)	1 - 99	48
C FAX : LOW	RSPF FAX mode exposure adjustment (Low density side)	1 - 99	48
D COPY : HIGH	RSPF copy mode exposure adjustment (High density side)	1 - 99	53
E SCAN : HIGH	RSPF scanner mode exposure adjustment (Low density side)	1 - 99	53
F FAX : HIGH	RSPF FAX mode exposure adjustment (high density)	1 - 99	53

46-10

<b>Purpose</b>	Adjustment
<b>Function (Purpose)</b>	Used to adjust the copy color balance and the gamma (for each color copy mode).

**Section****Operation/Procedure**

- 1) Select an adjustment target mode with the touch panel key.
- 2) Select an adjustment target color with [K][C][M][Y] keys on the touch panel.
- 3) Select an adjustment target item with scroll key on the touch panel.
- 4) Enter the set value with 10-key.
  - \* When the  $\Delta$   $\nabla$  key is pressed, the setting value of each item can be changed with 1up (1down) collectively.
- 5) Press [OK] key. (The set value is saved.)

When the adjustment value is increased, the image density is increased, and vice versa.

TEXT	Text
TEXT/PRT PHOTO	Text/Printed Photo
PRINTED PHOTO	Printed Photo
PHOTO + TEXT/PHOTO	Photograph + Text/Printed Photo
MAP	Map
LIGHT	Light document
COPY ORG	Copy document

Item/Display	Density level (Point)	Setting range	Default value
A POINT1	Point 1	1 - 999	500
B POINT2	Point 2	1 - 999	500
C POINT3	Point 3	1 - 999	500
D POINT4	Point 4	1 - 999	500
E POINT5	Point 5	1 - 999	500
F POINT6	Point 6	1 - 999	500
G POINT7	Point 7	1 - 999	500
H POINT8	Point 8	1 - 999	500
I POINT9	Point 9	1 - 999	500
J POINT10	Point 10	1 - 999	500
K POINT11	Point 11	1 - 999	500
L POINT12	Point 12	1 - 999	500
M POINT13	Point 13	1 - 999	500
N POINT14	Point 14	1 - 999	500
O POINT15	Point 15	1 - 999	500
P POINT16	Point 16	1 - 999	500
Q POINT17	Point 17	1 - 999	500

46-16

<b>Purpose</b>	Adjustment
<b>Function (Purpose)</b>	Used to adjust the monochrome copy density and the gamma (for each monochrome copy mode).

**Section****Operation/Procedure**

- 1) Select an adjustment target item with scroll key on the touch panel.
- 2) Enter the set value with 10-key.
  - \* When the  $\Delta$   $\nabla$  key is pressed, the setting value of each item can be changed with 1up (1down) collectively.
- 3) Press [OK] key. (The set value is saved.)

When the adjustment value is increased, the image density is increased, and vice versa.



Item/Display	Density level (Point)	Setting range	Default value	
A	POINT1	Point 1	1 - 999	500
B	POINT2	Point 2	1 - 999	500
C	POINT3	Point 3	1 - 999	500
D	POINT4	Point 4	1 - 999	500
E	POINT5	Point 5	1 - 999	500
F	POINT6	Point 6	1 - 999	500
G	POINT7	Point 7	1 - 999	500
H	POINT8	Point 8	1 - 999	500
I	POINT9	Point 9	1 - 999	500
J	POINT10	Point 10	1 - 999	500
K	POINT11	Point 11	1 - 999	500
L	POINT12	Point 12	1 - 999	500
M	POINT13	Point 13	1 - 999	500
N	POINT14	Point 14	1 - 999	500
O	POINT15	Point 15	1 - 999	500
P	POINT16	Point 16	1 - 999	500
Q	POINT17	Point 17	1 - 999	500

46-19

<b>Purpose</b>	Setting
<b>Function (Purpose)</b>	Used to set the operating conditions for the density scanning (exposure) of monochrome auto copy mode documents.

**Section**

**Operation/Procedure**

Select an item to be set with touch panel.

When an item is selected, it is highlighted and the setting change is saved.

Item/Display	Content	Set value	Default value
AE_MODE	Auto exposure mode	MODE1, MODE2	MODE1
AE_STOP_COPY	Auto B/W exposure Stop (for copy)	REALTIME/ STOP/ PRESCAN	STOP
AE_STOP_FAX	Auto B/W exposure Stop (for FAX)	ON/OFF	ON
AE_STOP_SCAN	Auto B/W exposure Stop (for scanner)	REALTIME/ STOP/ PRESCAN	STOP
AE_FILTER	Auto exposure filter setting	SOFT NORMAL SHARP	NORMAL
AE_WIDTH	AE exposure width	FULL/PART	FULL

**Note**

MODE 1	High gamma (high contrast images)
MODE 2	Normal gamma
STOP	The image density in 3 - 7mm area at the lead edge is scanned, and the output image density is determined according to the scanned density. (The output image density is even for all the surface.)
REALTIME	The densities of the document width are scanned sequentially, and the output image density is determined according to the density in each area of document. (The output image density may not be even for all the surface.)
PRESCAN	The densities of the all surface of document are scanned sequentially, and the output image density is determined according to the average of the scanned densities. (The output image density is even for all the surface.)
AE_WIDTH FULL	The document density scan area in the monochrome auto mode is 3 - 7mm at the document lead edge x the document width. This is not related to the PRESCAN mode.

AE WIDTH PART	The document density scan area in the monochrome auto mode is 3 - 7mm at the document lead edge x 100mm width. This is not related to the PRESCAN mode.
---------------	---

46-21

<b>Purpose</b>	Adjustment
<b>Function (Purpose)</b>	Copy color balance adjustment (Manual adjustment)

**Section**

**Operation/Procedure**

- 1) Select an adjustment target color with [K][C][M][Y] keys on the touch panel.
- 2) Select an adjustment target item with scroll key on the touch panel.
- 3) Enter the set value with 10-key.  
\* When the  $\Delta$   $\nabla$  key is pressed, the setting value of each item can be changed with 1up (1down) collectively.
- 4) Press [OK] key. (The set value is saved.)

When the adjustment value is increased, the image density is increased, and vice versa.

When [EXECUTE] key is pressed, the check pattern in printed in the color balance and density corresponding to the adjustment value.

Item/Display	Density level (Point)	Setting range	Default value	
A	POINT1	Point 1	1 - 999	500
B	POINT2	Point 2	1 - 999	500
C	POINT3	Point 3	1 - 999	500
D	POINT4	Point 4	1 - 999	500
E	POINT5	Point 5	1 - 999	500
F	POINT6	Point 6	1 - 999	500
G	POINT7	Point 7	1 - 999	500
H	POINT8	Point 8	1 - 999	500
I	POINT9	Point 9	1 - 999	500
J	POINT10	Point 10	1 - 999	500
K	POINT11	Point 11	1 - 999	500
L	POINT12	Point 12	1 - 999	500
M	POINT13	Point 13	1 - 999	500
N	POINT14	Point 14	1 - 999	500
O	POINT15	Point 15	1 - 999	500
P	POINT16	Point 16	1 - 999	500
Q	POINT17	Point 17	1 - 999	500

46-23

<b>Purpose</b>	Adjustment/Setup
<b>Function (Purpose)</b>	Used to set the density correction of copy high density section (High density tone gap supported).

**Section**

**Operation/Procedure**

- 1) Enter the set value with 10-key.

0	Enable
1	Inhibit

- 2) Press [OK] key. (The set value is saved.)

Item/Display	Content	Setting range	Default value		
A	CMY (0: ENABLE 1: DISABLE)	0	CMY engine highest density correction mode: Enable	0 - 1	0
		1	CMY engine highest density correction mode: Disable		

Item/Display		Content		Setting range	Default value
B	K (0: ENABLE 1: DISABLE)	0	K engine highest density correction mode: Enable	0 - 1	1
		1	K engine highest density correction mode: Disable		
C	CYAN MAX TARGET	Scanner target value for CYAN maximum density correction		0 - 999	500
D	MAGENTA MAX TARGET	Scanner target value for MAGENTA maximum density correction		0 - 999	500
E	YELLOW MAX TARGET	Scanner target value for YELLOW maximum density correction		0 - 999	500
F	BLACK MAX TARGET	Scanner target value for BLACK maximum density correction		0 - 999	500

\* When tone gap is generated in the high density area, set items A and B to "0".

The density of high density part decreases. However, the tone gap is better.

\* To increase the density in the high density area further, set items A and B to "1".

The tone gap may occur in high density part.

### Important

Do not change the values of items C, D, E, and F. If these values are changed, the density in the high density area is changed.

46-24	
<b>Purpose</b>	Adjustment
<b>Function (Purpose)</b>	Copy color balance adjustment (Auto adjustment)

### Section

#### Operation/Procedure

- Press [EXECUTE] key.  
The color patch image (adjustment pattern) is printed out.
- Place the printed adjustment pattern on the document table, select [FACTORY] or [SERVICE] mode.
- Press [EXECUTE] key.  
The copy color balance automatic adjustment is performed, then the adjustment result pattern is printed.
- Press [OK] key.  
The halftone correction target registration is processed.

46-25	
<b>Purpose</b>	Adjustment
<b>Function (Purpose)</b>	Used to adjust the copy color balance. (Single color copy mode)

### Section

#### Operation/Procedure

- Select an adjustment target color with [C][M][Y] keys on the touch panel.
- Select an adjustment target item with scroll key on the touch panel.
- Enter the set value with 10-key.
- Press [OK] key. (The set value is saved.)

When the adjustment value is increased, the image density of the target color is increased, and vice versa.

#### 18cpm/20cpm/23cpm/31cpm(G) machine

Item/Display	Setting range	Default value		
		C	M	Y
A RED	0 - 255	0	255	200

Item/Display	Setting range	Default value		
		C	M	Y
B GREEN	0 - 255	255	0	255
C BLUE	0 - 255	255	150	0
D CYAN	0 - 255	255	0	0
E MAGENTA	0 - 255	0	255	0
F YELLOW	0 - 255	0	0	255

#### 26cpm/36cpm/31cpm(A) machine

Item/Display	Setting range	Default value		
		C	M	Y
A RED	0 - 255	0	255	200
B GREEN	0 - 255	255	0	255
C BLUE	0 - 255	255	150	0
D CYAN	0 - 255	255	0	0
E MAGENTA	0 - 255	0	255	0
F YELLOW	0 - 255	0	0	255
G ORANGE	0 - 255	0	150	255
H NAVY	0 - 255	255	200	0
I LIGHT GREEN	0 - 255	150	0	150
J LIGHT BLUE	0 - 255	150	20	0
K AQUA MARINE	0 - 255	170	0	50
L PURPLE	0 - 255	128	255	0
M PINK	0 - 255	0	150	20
N YELLOW GREEN	0 - 255	128	0	255
O BEIGE	0 - 255	0	50	170

46-26	
<b>Purpose</b>	Adjustment
<b>Function (Purpose)</b>	Used to reset the single color mode color balance set value to the default.

### Section

#### Operation/Procedure

- Press [EXECUTE] key.
- Press [YES] key.  
The color balance value of the single color mode is reset to the default value.

46-27	
<b>Purpose</b>	Adjustment/Setup
<b>Function (Purpose)</b>	Used to adjust the gamma/density of copy images, texts, and line image edges.

### Section

#### Operation/Procedure

- Select a target item of setting with scroll key on the touch panel.
- Enter the set value with 10-key.
- Press [OK] key. (The set value is saved.)

Item/Display (Copy mode)	Content	Setting range	Default value
A BLACK TEXT (SLOPE)	Black character edge gamma skew adjustment	1 - 99	50
B BLACK TEXT (INTERCEPT)	Black character edge density adjustment	1 - 99	50
C COLOR TEXT (SLOPE)	Color character edge gamma skew adjustment	1 - 99	50
D COLOR TEXT (INTERCEPT)	Color character edge density adjustment	1 - 99	50
E ED TEXT (SLOPE)	Text/Map mode gamma adjustment (Text/Map mode)	1 - 99	50
F ED TEXT (INTERCEPT)	Text/Map mode density adjustment (Text/Map mode)	1 - 99	50

When the adjustment values of items A, C, and E are changed, the gamma of text and line edge image density section is changed.

When the adjustment value is increased, the image contrast of character edge and line edge is increased. When the adjustment value is decreased, the image contrast of character and line edge is decreased.

When the adjustment values of items B, D, and F are increased, the image density of text and line edge section is decreased, and vice versa.

46-30

<b>Purpose</b>	Adjustment/Setup
<b>Function (Purpose)</b>	Used to adjust the resolution in the sub scanning direction in the copy mode.

**Section**

**Operation/Procedure**

- 1) Refer to the following table, and enter the set value corresponding to the resolution mode with 10-key.
- 2) Press [OK] key. (The set value is saved.)

Item/Display		Content		Setting range		Default value
A	SCAN RESOLUTION SW	Scan resolution selection (COPY: COLOR)	Mode1	0 - 1	0	0
			Mode2		1	

Mode	Scan mode	Resolution in the sub scanning direction (DPI)		
		25-99% [Magnification ratio]	100-200% [Magnification ratio]	201-400% [Magnification ratio]
Mode1	OC	600	600	1200
	RSPF	600	600	1200

46-36

<b>Purpose</b>	Adjustment/Setup
<b>Function (Purpose)</b>	Used to adjust the colors in the 2-color copy mode.

**Section**

**Operation/Procedure**

- 1) Select a target adjustment item with scroll key on the touch panel.
- 2) Enter the set value with 10-key.
- 3) Press [OK] key. (The set value is saved.)

By changing the density level of each color, the color adjustment in the 2-color copy mode can be performed.

**26cpm/36cpm/31cpm(A) machine**

Item/Display	Content	Setting range	Default value			Default value	
			C	M	Y		
OUTCOLOR (Output color coefficient)	A RED	R output color	0 - 255	0	255	200	-
	B GREEN	G output color	0 - 255	255	0	255	-
	C BLUE	B output color	0 - 255	255	150	0	-
	D CYAN	C output color	0 - 255	255	0	0	-
	E MAGENTA	M output color	0 - 255	0	255	0	-
	F YELLOW	Y output color	0 - 255	0	0	255	-
	G ORANGE	O output color	0 - 255	0	150	255	-
	H NAVY	N output color	0 - 255	255	200	0	-
	I LIGHT GREEN	LG output color	0 - 255	150	0	150	-
	J LIGHT BLUE	LB output color	0 - 255	150	20	0	-
	K AQUA MARINE	AM output color	0 - 255	170	0	50	-
	L PURPLE	PU output color	0 - 255	128	255	0	-
	M PINK	P output color	0 - 255	0	150	20	-
	N YELLOW GREEN	YG output color	0 - 255	128	0	255	-
	O BEIGE	BE output color	0 - 255	0	50	170	-

Mode	Scan mode	Resolution in the sub scanning direction (DPI)		
		25-99% [Magnification ratio]	100-200% [Magnification ratio]	201-400% [Magnification ratio]
Mode2	OC	300	600	1200
	RSPF	400	600	1200

46-32

<b>Purpose</b>	Adjustment/Setup
<b>Function (Purpose)</b>	Used to adjust the document background density reproducibility in the monochrome auto copy mode.

**Section**

**Operation/Procedure**

- 1) Select a target item of setting with scroll key on the touch panel.
- 2) Enter the set value with 10-key.
- 3) Press [OK] key. (The set value is saved.)

When the adjustment value is increased, reproducibility of the background and the low density image is increased. When the adjustment value is decreased, reproducibility of the background and the low density image is decreased.

[RSPF]

Item/Display		Content	Setting range	Default value
A	COPY : OC	Copy mode (for OC)	1 - 250	196
B	COPY : RSPF	Copy mode (for RSPF)	1 - 250	196
C	SCAN : OC	Scanner mode (for OC)	1 - 250	196
D	SCAN : RSPF	Scanner mode (for RSPF)	1 - 250	196
E	FAX : OC	FAX mode (for OC)	1 - 250	196
F	FAX : RSPF	FAX mode (for RSPF)	1 - 250	196

**18cpm/20cpm/23cpm/31cpm(G) machine**

Item/Display	Content	Setting range	Default value			
			C	M	Y	
A	RED	R output color	0 - 255	0	255	200
B	GREEN	G output color	0 - 255	255	0	255
C	BLUE	B output color	0 - 255	255	150	0
D	CYAN	C output color	0 - 255	255	0	0
E	MAGENTA	M output color	0 - 255	0	255	0
F	YELLOW	Y output color	0 - 255	0	0	255

Item/Display			Content	Setting range	Default value			Default value
					C	M	Y	
CHROMA (Chroma adjustment)	A	RED / BLACK	Red extraction mode (The red recognition area is adjusted.)	0 - 6	-	-	-	3
	B	KS:CHROMATIC	Chromatic color extraction mode (The chromatic color recognition area is adjusted.)	0 - 6	-	-	-	3

46-37

<b>Purpose</b>	Adjustment/Setup
<b>Function (Purpose)</b>	Used to adjust the reproduction capability of monochrome mode color.
<b>Section</b>	

**Operation/Procedure**

- 1) Select a target item with scroll keys on the touch panel.
- 2) Enter the set value with 10-key.
- 3) Press [EXECUTE] key.
- 4) Press [YES] key.

This is to adjust the reproduction capability of red and yellow images when copying color documents with red and yellow images in the monochrome mode.

**18cpm/20cpm/23cpm/31cpm(G) machine**

Applied to the copy mode only.

Item/Display	Content	Setting range	Default value
A R-Ratio	Gray making setting (R)	0 - 1000	63
B G-Ratio	Gray making setting (G)	0 - 1000	877

**26cpm/36cpm/31cpm(A) machine**

An individual adjustment is available in each of the copy mode and the printer mode.

Item/Display	Content	Setting range	Default value
A R-Ratio	Gray making setting (R)	0 - 1000	63
B G-Ratio	Gray making setting (G)	0 - 1000	877
C R-Ratio RIP	Print gray making setting (R)	0 - 1000	299
D G-Ratio RIP	Print gray making setting (G)	0 - 1000	587

B-Ratio	Gray making setting (B) (1000-R-Ratio - G-Ratio)
B-Ratio RIP	Print gray making setting (B) (1000-R-Ratio RIP - G-Ratio RIP)

\* B-Ratio: The value of gray making setting (B) is obtained from the formula below.

$$1000 - R - Ratio - G - Ratio$$

When [DEFAULT] key is pressed, the values are set to the initial values (Default).

When the adjustment value of the adjustment item A is increased, the copy density of red images is increased. When the adjustment value is decreased, the density is increased.

When the adjustment value of the adjustment item B is increased, the copy density of yellow images is increased. When the adjustment value is decreased, the density is also decreased.

46-38

<b>Purpose</b>	Adjustment/Setup
<b>Function (Purpose)</b>	Used to adjust the black component amount in the color copy mode.
<b>Section</b>	

**Operation/Procedure**

- 1) Select the AUTO MODE or the MANUAL MODE with the mode key.
- 2) Select the mode to be adjusted with the scroll key.
- 3) Press the black component amount select key.

This adjusts black ingredient amount in the color copy mode. (except character and line image)

As a result of this adjustment, the gradation of the shade part changes.

Item/Display (Copy mode)	Select button	Content	Default value
MANUAL TEXT PRT	(-) LUT2	Text print (Manual)	NORMAL
	(-) LUT1		
	NOMAL		
	(+) LUT1		
	(+) LUT2		
TEXT	(-) LUT2	Text (Manual)	NORMAL
	(-) LUT1		
	NOMAL		
	(+) LUT1		
	(+) LUT2		
PRINTED PHOTO	(-) LUT2	Printed photo (Manual)	NORMAL
	(-) LUT1		
	NOMAL		
	(+) LUT1		
	(+) LUT2		
PHOTO	(-) LUT2	Photograph/Text photograph (Manual)	NORMAL
	(-) LUT1		
	NOMAL		
	(+) LUT1		
	(+) LUT2		
TEXT PHOTO	(-) LUT2	Text/Photograph (Manual)	NORMAL
	(-) LUT1		
	NOMAL		
	(+) LUT1		
	(+) LUT2		
MAP	(-) LUT2	Map (Manual)	NORMAL
	(-) LUT1		
	NOMAL		
	(+) LUT1		
	(+) LUT2		
CP ORG/ TEXT PRT	(-) LUT2	Copy document/ Text printed (Manual)	NORMAL
	(-) LUT1		
	NOMAL		
	(+) LUT1		
	(+) LUT2		
COPY ORG/ TEXT	(-) LUT2	Copy document/ Text (Manual)	NORMAL
	(-) LUT1		
	NOMAL		
	(+) LUT1		
	(+) LUT2		

Item/Display (Copy mode)		Select button	Content	Default value
MANUAL	COPY ORG/ PHOTO	(-) LUT2	Copy document/ Printed photo (Manual)	NORMAL
		(-) LUT1		
		NOMAL		
		(+) LUT1		
		(+) LUT2		
	LIGHT ORIGINAL	(-) LUT2	Light document (Manual)	NORMAL
		(-) LUT1		
		NOMAL		
		(+) LUT1		
		(+) LUT2		
AUTO	AUTO0	(-) LUT2	Auto mode judgment 0	NORMAL
		(-) LUT1		
		NOMAL		
		(+) LUT1		
		(+) LUT2		
	AUTO1	(-) LUT2	Auto mode judgment 1	NORMAL
		(-) LUT1		
		NOMAL		
		(+) LUT1		
		(+) LUT2		
	AUTO2	(-) LUT2	Auto mode judgment 2	NORMAL
		(-) LUT1		
		NOMAL		
		(+) LUT1		
		(+) LUT2		
	AUTO3	(-) LUT2	Auto mode judgment 3	NORMAL
		(-) LUT1		
		NOMAL		
		(+) LUT1		
		(+) LUT2		
	AUTO4	(-) LUT2	Auto mode judgment 4	NORMAL
		(-) LUT1		
		NOMAL		
		(+) LUT1		
(+) LUT2				
AUTO5	(-) LUT2	Auto mode judgment 5	NORMAL	
	(-) LUT1			
	NOMAL			
	(+) LUT1			
	(+) LUT2			
AUTO6	(-) LUT2	Auto mode judgment 6	NORMAL	
	(-) LUT1			
	NOMAL			
	(+) LUT1			
	(+) LUT2			

**46-39**

**Purpose** Adjustment/Setup  
**Function (Purpose)** Used to adjust the sharpness of FAX send images.

**Section**

**Operation/Procedure**

- 1) Select a target item with scroll keys on the touch panel.
- 2) Enter the set value with 10-key.
- 3) Press [OK] key. (The set value is saved.)

Input small numeric value to obtain crispy image. Input large numeric value to decrease moire.

Item/Display	Content	Setting range	Default value
A	200 x 100 [DPI] OFF 200 x 100 [DPI] halftone OFF	0 - 2	1
B	200 x 200 [DPI] OFF 200 x 200 [DPI] halftone OFF	0 - 2	1
C	200 x 200 [DPI] ON 200 x 200 [DPI] halftone ON	0 - 2	1

Item/Display	Content	Setting range	Default value
D	200 x 400 [DPI] OFF 200 x 400 [DPI] halftone OFF	0 - 2	1
E	200 x 400 [DPI] ON 200 x 400 [DPI] halftone ON	0 - 2	1
F	400 x 400 [DPI] OFF 400 x 400 [DPI] halftone OFF	0 - 2	1
G	400 x 400 [DPI] ON 400 x 400 [DPI] halftone ON	0 - 2	1
H	600 x 600 [DPI] OFF 600 x 600 [DPI] halftone OFF	0 - 2	1
I	600 x 600 [DPI] ON 600 x 600 [DPI] halftone ON	0 - 2	1

**46-40**

**Purpose** Adjustment/Setup  
**Function (Purpose)** Used to adjust the FAX send image density. (Collective adjustment of all the modes)

**Section**

**Operation/Procedure**

- 1) Set the document on the document table.
- 2) Enter the set value with 10-key.
- 3) Press [EXECUTE] key, or [OK] key  
When [EXECUTE] key is pressed, the adjustment value is set and the scanned document image is outputted.

Item/Display	Content	Setting range	Default value
A	EXPOSURE LEVEL(ALL) Used to adjust the FAX send image density. (Collective adjustment of all the modes)	1 - 99	50

**46-41**

**Purpose** Adjustment/Setup  
**Function (Purpose)** Used to adjust the FAX send image density. (Normal)

**Section**

**Operation/Procedure**

- 1) Set the document on the document table.
- 2) Enter the set value with 10-key.
- 3) Press [EXECUTE] key, or [OK] key  
When [EXECUTE] key is pressed, the adjustment value is set and the scanned document image is outputted.

Item/Display	Content	Setting range	Default value
A	AUTO	Auto	1 - 99 50
B	EXPOSURE1	Exposure 1	1 - 99 50
C	EXPOSURE2	Exposure 2	1 - 99 50
D	EXPOSURE3	Exposure 3	1 - 99 50
E	EXPOSURE4	Exposure 4	1 - 99 50
F	EXPOSURE5	Exposure 5	1 - 99 50
G	EXECUTE MODE	AUTO Print mode Auto Exposure 1 Exposure 2 Exposure 3 Exposure 4 Exposure 5	1 - 6 1 2 3 4 5 6 (AUTO)

To check the adjustment density level of items A - F, set the document and set the setting value of item G according to items A - F, and press [EXECUTE] key.

46-42

<b>Purpose</b>	Adjustment/Setup
<b>Function (Purpose)</b>	Used to adjust the FAX send image density. (Fine)

**Section****Operation/Procedure**

- 1) Set the document on the document table.
- 2) Enter the set value with 10-key.
- 3) Press [EXECUTE] key, or [OK] key

When [EXECUTE] key is pressed, the adjustment value is set and the scanned document image is outputted.

Item/Display	Content	Setting range	Default value
A	AUTO	Fine/Automatic	1 - 99 50
B	EXPOSURE1	Fine/Exposure 1	1 - 99 50
C	EXPOSURE2	Fine/Exposure 2	1 - 99 50
D	EXPOSURE3	Fine/Exposure 3	1 - 99 50
E	EXPOSURE4	Fine/Exposure 4	1 - 99 50
F	EXPOSURE5	Fine/Exposure 5	1 - 99 50
G	AUTO H_TONE	Fine/Automatic/ Half-tone	1 - 99 50
H	EXPOSURE1 H_TONE	Fine/Exposure 1/ Half-tone	1 - 99 50
I	EXPOSURE2 H_TONE	Fine/Exposure 2/ Half-tone	1 - 99 50
J	EXPOSURE3 H_TONE	Fine/Exposure 3/ Half-tone	1 - 99 50
K	EXPOSURE4 H_TONE	Fine/Exposure 4/ Half-tone	1 - 99 50
L	EXPOSURE5 H_TONE	Fine/Exposure 5/ Half-tone	1 - 99 50
M	EXECUTE MODE	AUTO	1 - 12 1 2 3 4 5 6 7 8 9 10 11 12 1 (AUTO)
		EXP1	
		EXP2	
		EXP3	
		EXP4	
		EXP5	
		AUTO H_TONE	
		EXP1 H_TONE	
		EXP2 H_TONE	
		EXP3 H_TONE	
		EXP4 H_TONE	
		EXP5 H_TONE	

To check the adjustment density level of items A - L, set the document and set the setting value of item M according to items A - L, and press [EXECUTE] key.

46-43

<b>Purpose</b>	Adjustment/Setup
<b>Function (Purpose)</b>	Used to adjust the FAX send image density. (Super Fine)

**Section****Operation/Procedure**

- 1) Set the document on the document table.
- 2) Enter the set value with 10-key.
- 3) Press [EXECUTE] key, or [OK] key

When [EXECUTE] key is pressed, the adjustment value is set and the scanned document image is outputted.

Item/Display	Content	Setting range	Default value
A	AUTO	Super Fine/Auto	1 - 99 50
B	EXPOSURE1	Super Fine/ Exposure 1	1 - 99 50
C	EXPOSURE2	Super Fine/ Exposure 2	1 - 99 50
D	EXPOSURE3	Super Fine/ Exposure 3	1 - 99 50
E	EXPOSURE4	Super Fine/ Exposure 4	1 - 99 50
F	EXPOSURE5	Super Fine/ Exposure 5	1 - 99 50
G	AUTO H_TONE	Super Fine/ Auto/Half-tone	1 - 99 50
H	EXPOSURE1 H_TONE	Super Fine/ Exposure 1/Half-tone	1 - 99 50
I	EXPOSURE2 H_TONE	Super Fine/ Exposure 2/Half-tone	1 - 99 50
J	EXPOSURE3 H_TONE	Super Fine/ Exposure 3/Half-tone	1 - 99 50
K	EXPOSURE4 H_TONE	Super Fine/ Exposure 4/Half-tone	1 - 99 50
L	EXPOSURE5 H_TONE	Super Fine/ Exposure 5/Half-tone	1 - 99 50
M	EXECUTE MODE	AUTO	1 - 12 1 2 3 4 5 6 7 8 9 10 11 12 1 (AUTO)
		EXP1	
		EXP2	
		EXP3	
		EXP4	
		EXP5	
		AUTO H_TONE	
		EXP1 H_TONE	
		EXP2 H_TONE	
		EXP3 H_TONE	
		EXP4 H_TONE	
		EXP5 H_TONE	

To check the adjustment density level of items A - L, set the document and set the setting value of item M according to items A - L, and press [EXECUTE] key.

<b>Purpose</b>	Adjustment/Setup
<b>Function (Purpose)</b>	Used to adjust the FAX send image density. (Ultra fine)

**Section****Operation/Procedure**

- 1) Set the document on the document table.
- 2) Enter the set value with 10-key.
- 3) Press [EXECUTE] key, or [OK] key

When [EXECUTE] key is pressed, the adjustment value is set and the scanned document image is outputted.

Item/Display	Content	Setting range	Default value
A	AUTO	Ultra Fine/Auto	1 - 99 50
B	EXPOSURE1	Ultra Fine/Exposure 1	1 - 99 50
C	EXPOSURE2	Ultra Fine/Exposure 2	1 - 99 50
D	EXPOSURE3	Ultra Fine/Exposure 3	1 - 99 50
E	EXPOSURE4	Ultra Fine/Exposure 4	1 - 99 50
F	EXPOSURE5	Ultra Fine/Exposure 5	1 - 99 50
G	AUTO H_TONE	Ultra Fine/Auto/ Halftone	1 - 99 50
H	EXPOSURE1 H_TONE	Ultra Fine/ Exposure 1/Halftone	1 - 99 50
I	EXPOSURE2 H_TONE	Ultra Fine/ Exposure 2/Halftone	1 - 99 50
J	EXPOSURE3 H_TONE	Ultra Fine/ Exposure 3/Halftone	1 - 99 50
K	EXPOSURE4 H_TONE	Ultra Fine/ Exposure 4/Halftone	1 - 99 50
L	EXPOSURE5 H_TONE	Ultra Fine/ Exposure 5/Halftone	1 - 99 50
M	EXECUTE MODE	Print mode	1 - 12 1 (AUTO)
	AUTO	Ultra Fine/Auto	1
	EXP1	Ultra Fine/Exposure 1	2
	EXP2	Ultra Fine/Exposure 2	3
	EXP3	Ultra Fine/Exposure 3	4
	EXP4	Ultra Fine/Exposure 4	5
	EXP5	Ultra Fine/Exposure 5	6
	AUTO H_TONE	Ultra Fine/Auto/ Halftone	7
	EXP1 H_TONE	Ultra Fine/Exposure 1/ Halftone	8
	EXP2 H_TONE	Ultra Fine/Exposure 2/ Halftone	9
	EXP3 H_TONE	Ultra Fine/Exposure 3/ Halftone	10
	EXP4 H_TONE	Ultra Fine/Exposure 4/ Halftone	11
	EXP5 H_TONE	Ultra Fine/Exposure 5/ Halftone	12

To check the adjustment density level of items A - L, set the document and set the setting value of item M according to items A - L, and press [EXECUTE] key.

<b>Purpose</b>	Adjustment/Setup
<b>Function (Purpose)</b>	Used to adjust the FAX send image density. (600dpi).

**Section****Operation/Procedure**

- 1) Set the document on the document table.
- 2) Enter the set value with 10-key.
- 3) Press [EXECUTE] key, or [OK] key

When [EXECUTE] key is pressed, the adjustment value is set and the scanned document image is outputted.

Item/Display	Content	Setting range	Default value
A	AUTO	600dpi/Auto 1	1 - 99 50
B	EXPOSURE1	600dpi/Exposure 1	1 - 99 50
C	EXPOSURE2	600dpi/Exposure 2	1 - 99 50
D	EXPOSURE3	600dpi/Exposure 3	1 - 99 50
E	EXPOSURE4	600dpi/Exposure 4	1 - 99 50
F	EXPOSURE5	600dpi/Exposure 5	1 - 99 50
G	AUTO H_TONE	600dpi/Auto/ Halftone 1	1 - 99 50
H	EXPOSURE1 H_TONE	600dpi/Exposure 1/ Halftone	1 - 99 50
I	EXPOSURE2 H_TONE	600dpi/Exposure 2/ Halftone	1 - 99 50
J	EXPOSURE3 H_TONE	600dpi/Exposure 3/ Halftone	1 - 99 50
K	EXPOSURE4 H_TONE	600dpi/Exposure 4/ Halftone	1 - 99 50
L	EXPOSURE5 H_TONE	600dpi/Exposure 5/ Halftone	1 - 99 50
M	EXECUTE MODE	Print mode	1 - 12 1 (AUTO)
	AUTO	600dpi/Auto	1
	EXP1	600dpi/Exposure 1	2
	EXP2	600dpi/Exposure 2	3
	EXP3	600dpi/Exposure 3	4
	EXP4	600dpi/Exposure 4	5
	EXP5	600dpi/Exposure 5	6
	AUTO H_TONE	600dpi/Auto/ Halftone	7
	EXP1 H_TONE	600dpi/Exposure 1/ Halftone	8
	EXP2 H_TONE	600dpi/Exposure 2/ Halftone	9
	EXP3 H_TONE	600dpi/Exposure 3/ Halftone	10
	EXP4 H_TONE	600dpi/Exposure 4/ Halftone	11
	EXP5 H_TONE	600dpi/Exposure 5/ Halftone	12

To check the adjustment density level of items A - L, set the document and set the setting value of item M according to items A - L, and press [EXECUTE] key.

46-46

<b>Purpose</b>	Adjustment/Setup
<b>Function (Purpose)</b>	Used to adjust the FAX send image density. (RGB RIP) (26cpm/36cpm/31cpm(A) machine)

**Section****Operation/Procedure**

- 1) Select a target mode for adjustment.
- 2) Set the document on the document table.
- 3) Enter the set value with 10-key.
- 4) Press [OK] key.

When the set value is increased, the density becomes higher.  
When the set value is decreased, the density becomes lower.

	Item/Display	Content	Setting range	Default value
A	STANDARD RIP	For Normal/ Halftone OFF mode	1 - 99	50
B	FINE RIP	For Fine/Halftone OFF mode	1 - 99	50
C	FINE RIP H_TONE	For Fine/Halftone ON mode	1 - 99	50
D	SUPER FINE RIP	For Super Fine/ Halftone OFF mode	1 - 99	50
E	SUPER FINE RIP H_TONE	For Super Fine/ Halftone ON mode	1 - 99	50
F	ULTRA FINE RIP	For Ultra fine/ Halftone OFF mode	1 - 99	50
G	ULTRA FINE RIP H_TONE	For Ultra fine/ Halftone ON mode	1 - 99	50
H	600DPI RIP	For 600dpi/ Halftone OFF mode	1 - 99	50
I	600DPI RIP H_TONE	For 600dpi/ Halftone ON mode	1 - 99	50

46-47

<b>Purpose</b>	Adjustment/Setup
<b>Function (Purpose)</b>	Used to set the compression rate of copy and scan images (JPEG).

**Section****Operation/Procedure**

- 1) Select a target item with scroll keys on the touch panel.
- 2) Enter the set value with 10-key.
- 3) Press [OK] key.  
The set value is saved.

**18cpm/20cpm/23cpm/31cpm(G) machine**

Operation mode		Item/Display	Content	Setting range	Default value	
FILLING (COLOR) (COPY (COLOR mode))* <sup>1</sup>	A	COPY (C)	LOW	Low compression (Color)	0	0 (LOW)
			MIDDLE	Medium compression (Color)	1	
			HIGH	High compression (Color)	2	
FILLING (GRAY) (COPY (Monochrome halftone mode))* <sup>1</sup>	B	COPY (G)	LOW	Low compression (Gray)	0	0 (LOW)
			MIDDLE	Medium compression (Gray)	1	
			HIGH	High compression (Gray)	2	
PUSH SCAN (COLOR) (Scanner (Color mode))	C	SCAN (C) * <sup>1</sup>	MIDDLE 1	Medium compression mode 1 Low compression	0	1 (MIDDLE 2)
			MIDDLE 2	Medium compression mode 2 Medium compression	1	
			MIDDLE 3	Medium compression mode 3 High compression	2	
PUSH SCAN (GRAY) (Scanner (Monochrome halftone mode))	D	SCAN (G) * <sup>2</sup>	MIDDLE 1	Medium compression mode 1 Low compression	0	1 (MIDDLE 2)
			MIDDLE 2	Medium compression mode 2 Medium compression	1	
			MIDDLE 3	Medium compression mode 3 High compression	2	

\*1: 20cpm machine: Disable without HDD.

\*2: Setting of compression rate for images when the image compression rate is set to "Medium" in the user mode.



26cpm/36cpm/31cpm(A) machine

Operation mode	Item/Display		Content	Setting range	Default value	
FILLING (COLOR) Filing (Color mode)	A	FILLING (C)	LOW	Low compression (Color)	0	0 (LOW)
			MIDDLE	Medium compression (Color)	1	
			HIGH	High compression (Color)	2	
FILLING (GRAY) Filing (Monochrome halftone mode)	B	FILLING (G)	LOW	Low compression (Halftone)	0	0 (LOW)
			MIDDLE	Medium compression (Monochrome halftone mode)	1	
			HIGH	High compression (Monochrome halftone mode)	2	
PRINT HOLD (COLOR) Print hold (Color mode)	C	PRINT (C)	LOW	Low compression (Color)	0	0 (LOW)
			MIDDLE	Medium compression (Color)	1	
			HIGH	High compression (Color)	2	
PRINT HOLD (GRAY) Print hold (Monochrome halftone mode)	D	PRINT (G)	LOW	Low compression (Halftone)	0	0 (LOW)
			MIDDLE	Medium compression (Monochrome halftone mode)	1	
			HIGH	High compression (Monochrome halftone mode)	2	

Operation mode	Item/Display		Content	Setting range	Default value	
PUSH SCAN (COLOR) (Scanner color)	E	SCAN (C) *1	MIDDLE 1	Medium compression mode 1 Low compression	0	1 (MIDDLE 2)
			MIDDLE 2	Medium compression mode 2 Medium compression	1	
			MIDDLE 3	Medium compression mode 3 High compression	2	
PUSH SCAN (GRAY) (Scanner monochrome halftone mode)	F	SCAN (G) *1	MIDDLE 1	Medium compression mode 1 Low compression	0	1 (MIDDLE 2)
			MIDDLE 2	Medium compression mode 2 Medium compression	1	
			MIDDLE 3	Medium compression mode 3 High compression	2	

\*1: Setting of compression rate for images when the image compression rate is set to "Medium" in the user mode.

**Note**

When the compression rate is increased, the HDD capacity in the document filing mode is decreased. On the other hand, however, the image quality of some documents may be remarkably reduced.

46-51

<b>Purpose</b>	Adjustment/Setup
<b>Function (Purpose)</b>	Used to adjust the gamma for the copy mode heavy paper mode and the image process mode.

**Section****Operation/Procedure**

- 1) Select a target adjustment mode with the touch panel key [PAPER/DITHER].
- 2) Select an adjustment target color with [K][C][M][Y] keys on the touch panel.
- 3) Select a target adjustment density level with scroll key on the touch panel.
- 4) Enter the set value with 10-key.
- 5) Press [EXECUTE] key, or [OK] key.

When [EXECUTE] key is pressed, the self print image is out-putted.

When the image density is insufficient or a background copy is made in heavy paper copy, change this adjustment value to adjust the image density.

Item/Display	Content	Color
HEAVY* <sup>1</sup>	Copier heavy paper gamma	KCMY
DITH1* <sup>1</sup>	Black edge	K
DITH2* <sup>1</sup>	Color edge	KCMY
DITH3	Color error diffusion	KCMY
DITH4	Monochrome error diffusion	K
DITH8* <sup>1</sup>	Monochrome dither	K

\*1: 18cpm/20cpm machine: Disable without HDD.

	Item/Display	Density level (Point)	Setting range	Default value
A	POINT1	Point 1	1 - 999	500
B	POINT2	Point 2	1 - 999	500
C	POINT3	Point 3	1 - 999	500
D	POINT4	Point 4	1 - 999	500
E	POINT5	Point 5	1 - 999	500
F	POINT6	Point 6	1 - 999	500
G	POINT7	Point 7	1 - 999	500
H	POINT8	Point 8	1 - 999	500
I	POINT9	Point 9	1 - 999	500
J	POINT10	Point 10	1 - 999	500
K	POINT11	Point 11	1 - 999	500
L	POINT12	Point 12	1 - 999	500
M	POINT13	Point 13	1 - 999	500
N	POINT14	Point 14	1 - 999	500
O	POINT15	Point 15	1 - 999	500
P	POINT16	Point 16	1 - 999	500
Q	POINT17	Point 17	1 - 999	500

46-52

<b>Purpose</b>	Adjustment/Setup
<b>Function (Purpose)</b>	Used to set the gamma default for the copy mode heavy paper and the image process mode. (After execution of either SIM46-54 or SIM46-51, the adjustment value is reset to the initial value.)

**Section****Operation/Procedure**

- 1) Select an item to be set to the default with the touch panel key.  
To reset the adjustment values of all the items, select [ALL].
- 2) Press [EXECUTE] key.
- 3) Press [YES] key.

46-54

<b>Purpose</b>	Adjustment
<b>Function (Purpose)</b>	Used to perform the engine halftone automatic density adjustment (dither).

**Section****Operation/Procedure**

- 1) Press [EXECUTE] key.  
The high density process control is started to make 48 patch self print. (A4 (11" x 8.5") or A3 (11" x 17") paper in the paper feed tray is used.)
- 2) Place the 48 patch self print on the document table, and press [EXECUTE] key.  
Scanning the 48 patch self print is started.  
After scanning the 48 patch self print, the 17 patch self print is automatically printed.
- 3) Press [OK] key.  
After completion of the correction amount registration, the screen shifts to the dither selection menu.
- 4) Select an item (dither) to be adjusted.

**18cpm/20cpm/23cpm/31cpm(G) machine**

HEAVYPAPER* <sup>1</sup>	Copier/gamma for heavy paper
BLACK EDGE* <sup>1</sup>	Black edge
COLOR EDGE* <sup>1</sup>	Color edge
COLOR ED	Color error diffusion
B/W ED	Monochrome error diffusion
B/W 600* <sup>1</sup>	Monochrome dither 600dpi

\*1: 18cpm/20cpm machine: Disable without HDD.

**26cpm/36cpm/31cpm(A) machine**

HEAVYPAPER	Copier/gamma for heavy paper
BLACK EDGE	Black edge
COLOR EDGE	Color edge
COLOR ED	Color error diffusion
B/W ED	Monochrome error diffusion
B/W 600	Monochrome dither 600dpi
WOVEN1	Watermark mode 1
WOVEN2	Watermark mode 2
WOVEN3	Watermark mode 3
WOVEN4	Watermark mode 4

- 5) Press [EXECUTE] key.  
The 48 patch self print is printed.
- 6) Place the 48 patch self print on the document table, and press [EXECUTE] key.  
Scanning the 48 patch self print is started.  
After scanning the patch, the screen automatically shifts to the dither selection menu.
- 7) After completion of the adjustment of all the density adjustment items (dither), press [OK] key.

46-55

<b>Purpose</b>	Adjustment/Setup
<b>Function (Purpose)</b>	Used to adjust the drop out color in the image send mode (monochrome manual text mode). (26cpm/36cpm/31cpm(A) machine)

**Section****Operation/Procedure**

In the image send mode (monochrome manual text mode), the range where color images are reproduced as monochrome images is adjusted.

- Enter the adjustment value with 10-key and press [OK] key.  
When the adjustment value is increased, colors dropout becomes easy to narrow the reproduction range. When the adjustment value is decreased, color dropout becomes difficult to widen the reproduction range.

Item/Display	Content	Setting range	Default value
A	CHROMA	Dropout color range adjustment	0 - 6 3

- Scan the document in the image send mode (monochrome manual text mode), and check the adjustment result.

46-58

<b>Purpose</b>	Adjustment/Setup
<b>Function (Purpose)</b>	Used to set the copy mode pseudo resolution. (Smoothing process)

**Section****Operation/Procedure**

- Select an item (mode) to be set with the button and the scroll key.
  - Enter the set value with 10-key.
  - Press [OK] key.
- 1(ON): 9600 (equivalent) x 600 dpi  
0 (OFF): 600 x 600 dpi
- The setting is reflected only the image edge area.

Mode	Item/Display	Content (copy mode)	Setting range	Default value
COLOR	A	AUTO	Auto	OFF 0 ON 1 0 (OFF)
	B	TEXT	Text	OFF 0 ON 1 1 (ON)
	C	TEXT PRT	Text print	OFF 0 ON 1 0 (OFF)
	D	PRINTED PHOTO	Printed Photo	OFF 0 ON 1 0 (OFF)
	E	TEXT PHOTO	Text photograph	OFF 0 ON 1 0 (OFF)
	F	PHOTO	Photograph	OFF 0 ON 1 0 (OFF)
	G	MAP	Map	OFF 0 ON 1 1 (ON)
	H	LIGHT	Light document	OFF 0 ON 1 0 (OFF)
	I	CPY TO CPY/ TEXT	Text (copy document)	OFF 0 ON 1 1 (ON)
	J	CPY TO CPY/ TXT PRT	Text print (copy document)	OFF 0 ON 1 0 (OFF)
	K	CPY TO CPY/ PHOTO	Printed Photo (copy document)	OFF 0 ON 1 0 (OFF)

Mode	Item/Display	Content (copy mode)	Setting range	Default value
MONO	A	AUTO	Auto	OFF 0 ON 1 0 (OFF)
	B	TEXT	Text	OFF 0 ON 1 1 (ON)
	C	TEXT PRT	Text print	OFF 0 ON 1 0 (OFF)
	D	PRINTED PHOTO	Printed Photo	OFF 0 ON 1 0 (OFF)
	E	TEXT PHOTO	Text photograph	OFF 0 ON 1 0 (OFF)
	F	PHOTO	Photograph	OFF 0 ON 1 0 (OFF)
	G	MAP	Map	OFF 0 ON 1 1 (ON)
	H	LIGHT	Light document	OFF 0 ON 1 0 (OFF)
	I	CPY TO CPY/ TEXT	Text (copy document)	OFF 0 ON 1 1 (ON)
	J	CPY TO CPY/ TXT PRT	Text print (copy document)	OFF 0 ON 1 0 (OFF)
	K	CPY TO CPY/ PHOTO	Printed Photo (copy document)	OFF 0 ON 1 0 (OFF)

46-59

<b>Purpose</b>	Adjustment/Setup
<b>Function (Purpose)</b>	Used to perform the copy mode pseudo resolution image process adjustment.

**Section****Operation/Procedure**

- Select the MAIN (main scanning direction) or the SUB (sub scanning direction) button.
- Press the button of the adjustment value of the target copy mode.



This adjustment is valid when SIM46-58 Pseudo resolution setting is set to ON.

The thickness of images in the section processed by smoothing is changed.

Positive: The image in the section processed by smoothing becomes thicker.

Negative: The image in the section processed by smoothing becomes thinner.

Scanning direction	Item (copy mode)	Adjustment button	Content	Default value	NOTE
MAIN	COLOR COPY K	(-)2	Color copy For BLACK	0	Main scanning direction smoothing fine adjustment Negative (-) direction: The smoothing section becomes thinner. Positive (+) direction: The smoothing section becomes thicker.
		(-)1			
		0			
		(+)1			
		(+)2			
	COLOR COPY C	(-)2	Color copy For CYAN	0	
		(-)1			
		0			
		(+)1			
		(+)2			
	COLOR COPY M	(-)2	Color copy For MAGENTA	0	
		(-)1			
		0			
		(+)1			
		(+)2			
	COLOR COPY Y	(-)2	Color copy For YELLOW	0	
		(-)1			
		0			
		(+)1			
		(+)2			
	MONO COPY K	(-)2	Monochrome copy For BLACK	0	
		(-)1			
		0			
		(+)1			
		(+)2			
	COLOR PRINT K	(-)2	Color print For BLACK	0	
		(-)1			
		0			
		(+)1			
		(+)2			
	COLOR PRINT C	(-)2	Color print For CYAN	0	
		(-)1			
		0			
		(+)1			
		(+)2			
	COLOR PRINT M	(-)2	Color print For MAGENTA	0	
		(-)1			
		0			
		(+)1			
		(+)2			
	COLOR PRINT Y	(-)2	Color print For YELLOW	0	
		(-)1			
		0			
		(+)1			
		(+)2			
	MONO PRINT K	(-)2	Monochrome print For BLACK	0	
		(-)1			
		0			
(+)1					
(+)2					

Scanning direction	Item (copy mode)	Adjustment button	Content	Default value	NOTE
SUB	COLOR COPY K	(-)2	Color copy For BLACK	0	Sub scanning direction smoothing fine adjustment Negative (-) direction: The smoothing section becomes thinner. Positive (+) direction: The smoothing section becomes thicker.
		(-)1			
		0			
		(+)1			
		(+)2			
	COLOR COPY C	(-)2	Color copy For CYAN	0	
		(-)1			
		0			
		(+)1			
		(+)2			
	COLOR COPY M	(-)2	Color copy For MAGENTA	0	
		(-)1			
		0			
		(+)1			
		(+)2			
	COLOR COPY Y	(-)2	Color copy For YELLOW	0	
		(-)1			
		0			
		(+)1			
		(+)2			
	MONO COPY K	(-)2	Monochrome copy For BLACK	0	
		(-)1			
		0			
		(+)1			
		(+)2			
	COLOR PRINT K	(-)2	Color print For BLACK	0	
		(-)1			
		0			
		(+)1			
		(+)2			
	COLOR PRINT C	(-)2	Color print For CYAN	0	
		(-)1			
		0			
		(+)1			
		(+)2			
	COLOR PRINT M	(-)2	Color print For MAGENTA	0	
		(-)1			
		0			
		(+)1			
		(+)2			
	COLOR PRINT Y	(-)2	Color print For YELLOW	0	
		(-)1			
		0			
		(+)1			
		(+)2			
	MONO PRINT K	(-)2	Monochrome print For BLACK	0	
		(-)1			
		0			
(+)1					
(+)2					

<b>Purpose</b>	Adjustment/Setup
<b>Function (Purpose)</b>	Used to adjust the sharpness in the color auto copy mode.

<b>Section</b>
----------------

**Operation/Procedure**

- 1) Select a target item with scroll keys on the touch panel.
- 2) Input numeric value corresponding to sharpness level (filter process mode).
- 3) Press [OK] key.

This is used to adjust the sharpness in the color auto copy mode and the smoothness (roughness) in the dark area.

Item/Display		Content		Setting range	Default value	
A	SCREEN FILTER LEVEL	H	Sharpness (filter) adjustment of dot pattern image in auto copy mode	Strong emphasis	1	3 (Auto)
		L		Soft emphasis	2	
		AUTO		Auto	3	
B	CPY CL AUTO FILTER LEVEL	SOFT	Sharpness (filter) adjustment for the automatic copy mode (Text, Printed Photo / Printed Photo images)	SOFT	1	2 (CENTER)
		CENTER		CENTER	2	
		HIGH		HIGH	3	
C	CPY PUSH AUTO FILTER LEVEL	SOFT	Sharpness (filter) adjustment for the automatic push scan mode (Text, Printed Photo / Printed Photo images)	SOFT	1	2 (CENTER)
		CENTER		CENTER	2	
		HIGH		HIGH	3	
D	COLOR COPY : CMY	OFF	Soft filter applying setting to C, M, Y image in color copy mode	OFF	0	1 (ON)
		ON		ON	1	
E	COLOR COPY : K	OFF	Soft filter applying setting to K image in color copy mode	OFF	0	1 (ON)
		ON		ON	1	
F	SINGLE COLOR : CMY	OFF	Soft filter applying setting to C, M, Y image in single color copy mode	OFF	0	1 (ON)
		ON		ON	1	
G	2 COLOR COPY : CMY	OFF	Setting of YES/NO of applying the soft filter to C/M/Y images of the 2-color copy mode	OFF	0	1 (ON)
		ON		ON	1	
H	2 COLOR COPY : K	OFF	Setting of YES/NO of applying the soft filter to K images of the 2-color copy mode	OFF	0	1 (ON)
		ON		ON	1	
I	B/W COPY	OFF	Soft filter applying setting in monochrome copy mode	OFF	0	1 (ON)
		ON		ON	1	
J	COLOR PUSH : RGB	OFF	Soft filter applying setting to image in push scan color mode	OFF	0	1 (ON)
		ON		ON	1	
K	B/W PUSH	OFF	Soft filter applying setting to image in push scan monochrome mode	OFF	0	1 (ON)
		ON		ON	1	
L	COLOR PRINT: CMY*1	OFF	Setting of ON/OFF of soft filter application to color print C, M, Y images	OFF	0	0 (OFF)
		ON		ON	1	
M	COLOR PRINT: K*1	OFF	Setting of ON/OFF of soft filter application to color print K images	OFF	0	0 (OFF)
		ON		ON	1	
N	B/W PRINT*1	OFF	Setting of ON/OFF of soft filter application to monochrome print images	OFF	0	0 (OFF)
		ON		ON	1	

\*1: 18cpm/20cpm/23cpm/31cpm(G) machine: Disable

46-61

<b>Purpose</b>	Adjustment/Setup
<b>Function (Purpose)</b>	Used to adjust the area separation recognition level.

**Section****Operation/Procedure**

- 1) Select an adjustment mode.
- 2) Select a target adjustment item with scroll key on the touch panel.
- 3) Enter the adjustment value using the 10-key.
- 4) Press [OK] key.

**Important**

This must be set to the default unless any change is specially required.

When the adjustment value is set to a value greatly different from the default value, image quality trouble may occur for some documents.

Item/Display	Content	
COLOR	AUTO	[Color/Gray] Auto
	TPP	[Color/Gray] Manual (Text print)
	COPY(TPP)	[Color/Gray] Copy document (Text print)
MONO	AUTO	[Monochrome] Auto
	TPP	[Monochrome] Manual (Text print)
	COPY(TPP)	[Monochrome] Copy document (Text print)

Item/Display	Content	Setting range	Default value
A	SEGMENT: SWITCH [TXT ON SCR]	Detection ON/OFF: Text on dot	0 - 1 0
B	SEGMENT: SWITCH [LINE SCR]	Detection ON/OFF: line screen	0 - 1 0
C	SEGMENT: SWITCH [SMALL SCR]	Detection ON/OFF: Dot in a small area	0 - 1 0
D	SEGMENT: SWITCH [HIGH LPI]	Detection ON/OFF: High line number judgment select	0 - 1 0
E	SEGMENT: SWITCH [TXT ON SCR IMAGE SEND]	Detection ON/OFF: Text on image send dots	0 - 1 0
F	SEGMENT: ADJUST [BK TXT 1]	Detection level adjustment: Black text 1	1 - 99 50
G	SEGMENT: ADJUST [CL TXT 1]	Detection level adjustment: Color text 1	1 - 99 50
H	SEGMENT: ADJUST [BK TXT 2, CL TXT 2]	Detection level adjustment: Black text 2, Color text 2	1 - 49 25
I	SEGMENT: ADJUST [TXT ON SCR 1]	Detection level adjustment: Text 1 on dots	1 - 99 50
J	SEGMENT: ADJUST [TXT ON SCR 2]	Detection level adjustment: Text 2 on dots	1 - 99 50
K	SEGMENT: ADJUST [TXT ON SCR AREA]	Detection level adjustment: Detection area of text on dots	1 - 15 8
L	SEGMENT: ADJUST [HIGH LPI]	Detection level adjustment: High line number judgment	1 - 49 25
M	SEGMENT: ADJUST [BK]	Detection level adjustment: No chrome judgment	1 - 99 50
N	SEGMENT: ADJUST [CL]	Detection level adjustment: Chrome judgment	1 - 99 50
O	SEGMENT: ADJUST [TXT ON BG]	Detection level adjustment: Text on background	1 - 99 50

Item/Display	Content	Setting range	Default value
P	SEGMENT: ADJUST [SCR 1 HIGH]	Detection level adjustment: High density dots	1 - 49 25
Q	SEGMENT: ADJUST [SCR 1 MIDDLE]	Detection level adjustment: Medium density dots	1 - 49 25
R	SEGMENT: ADJUST [SCR 1 LOW]	Detection level adjustment: Low density dots	1 - 49 25
S	SEGMENT: ADJUST [SCR 2]	Detection level adjustment: Dot 2	1 - 15 8
T	SEGMENT: ADJUST [SCR 3]	Detection level adjustment: Dot 3	1 - 15 8
U	SEGMENT: ADJUST [LINE HALFTONE]	Detection level adjustment: line screen	1 - 49 25

46-62

<b>Purpose</b>	Adjustment/Setup
<b>Function (Purpose)</b>	Used to set the operating conditions of the ACS, the area separation, the background image process, and the auto exposure mode.

**Section****Operation/Procedure**

- 1) Select a target adjustment item with scroll key on the touch panel.
- 2) Enter the adjustment value using the 10-key.
- 3) Press [OK] key.

**Important**

This must be set to the default unless any change is specially required.

When the adjustment value is set to a value greatly different from the default value, image quality trouble may occur for some documents.

**18cpm/20cpm/23cpm/31cpm(G) machine**

Item/Display	Content	Setting range	Default value
A	SW_ACS	ACS judgment reference area select	0 - 1 1
B	TEXT_IMAGE	Text/Image judgment priority level adjustment	0 - 6 3
C	TEXT_BLANK	Text/Blank judgment priority level adjustment	0 - 6 4
D	HT_LV	Dot area judgment threshold value adjustment	0 - 6 1
E	AE_AREA_LV	Color AE judgment target area adjustment	0 - 6 3
F	AE_LV_CC	AE background detection division result adjustment: For color copy	0 - 8 4
G	AE_LV_MC	AE background detection division result adjustment: For monochrome copy	0 - 8 4
H	AE_LV_CS	AE background detection division result adjustment: For color scan	0 - 8 4
I	AE_LV_MS	AE background detection division result adjustment: For monochrome scan	0 - 8 4

Item/Display	Content		Setting range	Default value
J	AE_JUDGE_LV_L_U	Color AE background density threshold value adjustment (lower limit)	0 - 4	0
K	AE_JUDGE_LV_L_O	Color AE background density threshold value adjustment (upper limit)	0 - 10	0
L	AE_JUDGE_LV_C	Color AE background detection level adjustment (chroma)	0 - 10	5
M	AE_ONOFF_CC	AE mode ON/OFF switch: For color copy	0 - 1	0 (ON)
N	AE_ONOFF_MC	AE mode ON/OFF switch: For monochrome copy	0 - 1	0 (ON)
O	AE_ONOFF_CS	AE mode ON/OFF switch: For color scan	0 - 1	0 (ON)
P	AE_ONOFF_MS	AE mode ON/OFF switch: For monochrome copy	0 - 1	0 (ON)
Q	BLANK_JUDGE_LV_L	Blank judgment level adjustment (value)	0 - 10	0
R	BLANK_JUDGE_LV_C	Blank judgment level adjustment (chroma)	0 - 10	0
S	MODE0_UNDER	Mode 0 developing paper mode select	0 - 6	0
T	MODE1_UNDER	Mode 1 developing paper mode select	0 - 6	0
U	MODE5_UNDER	Mode 5 developing paper mode select	0 - 6	0
V	MODE6_UNDER	Mode 6 developing paper mode select	0 - 6	0

### 26cpm/36cpm/31cpm(A) machine

Item/Display	Content		Setting range	Default value
A	SW_ACS	ACS judgment reference area select	0 - 1	1
B	TEXT_IMAGE	Text/Image judgment priority level adjustment	0 - 6	3
C	TEXT_BLANK	Text/Blank judgment priority level adjustment	0 - 6	4
D	HT_LV	Dot area judgment threshold value adjustment	0 - 6	1
E	AE_AREA_LV	Color AE judgment target area adjustment	0 - 6	3
F	AE_LV_CC	AE background detection division result adjustment: For color copy	0 - 8	4
G	AE_LV_MC	AE background detection division result adjustment: For monochrome copy	0 - 8	4
H	AE_LV_CS	AE background detection division result adjustment: For color scan	0 - 8	4
I	AE_LV_MS	AE background detection division result adjustment: For monochrome scan	0 - 8	4
J	AE_JUDGE_LV_L_U	Color AE background density threshold value adjustment (lower limit)	0 - 4	0
K	AE_JUDGE_LV_L_O	Color AE background density threshold value adjustment (upper limit)	0 - 10	0
L	AE_JUDGE_LV_C	Color AE background detection level adjustment (chroma)	0 - 10	5

Item/Display	Content		Setting range	Default value
M	AE_ONOFF_CC	AE mode ON/OFF switch: For color copy	0 - 1	0 (ON)
N	AE_ONOFF_MC	AE mode ON/OFF switch: For monochrome copy	0 - 1	0 (ON)
O	AE_ONOFF_CS	AE mode ON/OFF switch: For color scan	0 - 1	0 (ON)
P	AE_ONOFF_MS	AE mode ON/OFF switch: For monochrome copy	0 - 1	0 (ON)
Q	BLANK_JUDGE_LV_L	Blank judgment level adjustment (value)	0 - 10	0
R	BLANK_JUDGE_LV_C	Blank judgment level adjustment (chroma)	0 - 10	0
S	MODE0_UNDER	Mode 0 developing paper mode select	0 - 6	0
T	MODE1_UNDER	Mode 1 developing paper mode select	0 - 6	0
U	MODE5_UNDER	Mode 5 developing paper mode select	0 - 6	0
V	MODE6_UNDER	Mode 6 developing paper mode select	0 - 6	0
W	SW_CHANGE_MODE0	Mode 0: Mode judgment select	0 - 6	0
X	SW_CHANGE_MODE1	Mode 1: Mode judgment select	0 - 6	1
Y	SW_CHANGE_MODE2	Mode 2: Mode judgment select	0 - 6	2
Z	SW_CHANGE_MODE3	Mode 3: Mode judgment select	0 - 6	3
AA	SW_CHANGE_MODE4	Mode 4: Mode judgment select	0 - 6	4
AB	SW_CHANGE_MODE5	Mode 5: Mode judgment select	0 - 6	5
AC	SW_CHANGE_MODE6	Mode 6: Mode judgment select	0 - 6	6

46-63

<b>Purpose</b>	Adjustment/Setup
<b>Function (Purpose)</b>	Used to adjust the density in the copy low density section.

**Section**

#### Operation/Procedure

- 1) Select a target adjustment item with scroll key on the touch panel.
- 2) Enter the adjustment value using the 10-key.
- 3) Press [OK] key.

When the adjustment value is increased, reproducibility of the background and the low density image is increased. When the adjustment value is decreased, reproducibility of the background and the low density image is decreased.

Item/Display	Content	Setting range	Default value
A	COLOR COPY : TEXT/PRINTED PHOTO	Text print (color copy)	1 - 9
B	COLOR COPY : TEXT	Text (color copy)	1 - 9
C	COLOR COPY : PRINTED PHOTO	Printed photo (color copy)	1 - 9
D	COLOR COPY : PHOTOGRAPH	Photograph (color copy)	1 - 9
E	COLOR COPY : TEXT/PHOTO	Text/Photograph (color copy)	1 - 9
F	COLOR COPY : MAP	Map (color copy)	1 - 9
G	COLOR COPY : LIGHT	Light document (color density)	1 - 9



	Item/Display	Content	Setting range	Default value
H	COLOR COPY : TEXT/PRINTED PHOTO (COPY TO COPY)	Copy document, Character print (color copy)	1 - 9	5
I	COLOR COPY : TEXT (COPY TO COPY)	Copy document, Character (color copy)	1 - 9	5
J	COLOR COPY : PRINTED PHOTO (COPY TO COPY)	Copy document, Printed photo (color copy)	1 - 9	5
K	COLOR PUSH : TEXT/PRINTED PHOTO	Text print (color PUSH)	1 - 9	3
L	COLOR PUSH : TEXT	Text (color PUSH)	1 - 9	3
M	COLOR PUSH : PRINTED PHOTO	Printed photo (color PUSH)	1 - 9	5
N	COLOR PUSH : PHOTOGRAPH	Photograph (color PUSH)	1 - 9	5
O	COLOR PUSH : TEXT/PHOTO	Text/Photograph (color PUSH)	1 - 9	3
P	COLOR PUSH : MAP	Map (color PUSH)	1 - 9	5

46-65

<b>Purpose</b>	Adjustment/Setup
<b>Function (Purpose)</b>	Used to set the color correction table.
<b>Section</b>	

#### Operation/Procedure

- 1) Select an adjustment mode.
- 2) Select an item (mode) to be set with the scroll key.
- 3) Enter the adjustment value using the 10-key.
- 4) Press [OK] key.

When the setting is changed, the color tone is changed. This function is used to make copies of different color tone for each copy mode.

The initial value must be set unless any special change is required.

Mode	Item/Display	Content	Setting range	Default value
COPY	A [MANUAL] TEXT PRT	Text print	0 - 8	0
	B [MANUAL] TEXT	Text	0 - 8	0
	C [MANUAL] PRINTED PHOTO	Printed Photo	0 - 8	0
	D [MANUAL] PHOTO	Photograph	0 - 8	1
	E [MANUAL] TEXT PHOTO	Text photograph	0 - 8	1
	F [MANUAL] MAP	Map	0 - 8	0
	G [MANUAL] LIGHT	Pencil	0 - 8	0
	H [MANUAL] CPT TO CPT/TXT PRT	Copy document/ Text print	0 - 8	0
	I [MANUAL] CPT TO CPT/TEXT	Copy document/ Text	0 - 8	0
	J [MANUAL] CPY TO CPY/PHOTO	Copy document/ Printed Photo	0 - 8	0
	K AUTO0	Automatic mode judgment 0	0 - 8	2
L AUTO1	Automatic mode judgment 1	0 - 8	2	

Mode	Item/Display	Content	Setting range	Default value
COPY	M AUTO2	Automatic mode judgment 2	0 - 8	3
	N AUTO3	Automatic mode judgment 3	0 - 8	3
	O AUTO4	Automatic mode judgment 4	0 - 8	2
	P AUTO5	Automatic mode judgment 5	0 - 8	2
	Q AUTO6	Automatic mode judgment 6	0 - 8	2
	PREVIEW (Preview screen)	A [MANUAL] TEXT PRT	Text print	0 - 4
B [MANUAL] TEXT		Text	0 - 4	0
C [MANUAL] PRINTED PHOTO		Printed Photo	0 - 4	0
D [MANUAL] PHOTO		Photograph	0 - 4	1
E [MANUAL] TEXT PHOTO		Text photograph	0 - 4	1
F [MANUAL] MAP		Map	0 - 4	0
G [MANUAL] LIGHT		Pencil	0 - 4	0
H [MANUAL] CPT TO CPT/TXT PRT		Copy document/ Text print	0 - 4	0
I [MANUAL] CPT TO CPT/TEXT		Copy document/ Text	0 - 4	0
J [MANUAL] CPY TO CPY/PHOTO		Copy document/ Printed Photo	0 - 4	0
K AUTO0		Automatic mode judgment 0	0 - 4	2
L AUTO1		Automatic mode judgment 1	0 - 4	2
M AUTO2		Automatic mode judgment 2	0 - 4	3
N AUTO3		Automatic mode judgment 3	0 - 4	3
O AUTO4	Automatic mode judgment 4	0 - 4	2	
P AUTO5	Automatic mode judgment 5	0 - 4	2	
Q AUTO6	Automatic mode judgment 6	0 - 4	2	

<b>Purpose</b>	Adjustment/Setup
<b>Function (Purpose)</b>	Used to adjust the reproduction capability of watermarks in the copy/printer mode. (26cpm/36cpm/31cpm(A) machine)

<b>Section</b>
----------------

**Operation/Procedure**

This is to adjust the reproduction capability of watermarks in the copy/printer mode.

- 1) Select the adjustment mode.
- 2) Select an adjustment item according to the necessity.
- 3) Enter the adjustment value with 10-key and press [OK] key.
- 4) Make a copy, and check the adjustment result.

	Item/Display	Content	Setting range	Default value	Note	
PATTERN	A	WOVEN DEN BK LOW	Watermark density level (Black LOW)	0 - 255	15	<p>The adjustment value is changed to increase or decrease the density of the watermark of background documents (primary output).</p> <p>To increase the watermark density, increase the adjustment value. To decrease the watermark density, decrease the adjustment value.</p> <p><b>Important</b></p> <p>When the adjustment value is increased, the watermark area which is originally not reproduced becomes difficult to disappear. When the adjustment value is decreased, the watermark area which is originally reproduced becomes easy to disappear.</p>
	B	WOVEN DEN BK MIDDLE	Watermark density level (Black MIDDLE)	0 - 255	19	
	C	WOVEN DEN BK HIGH	Watermark density level (Black HIGH)	0 - 255	23	
	D	WOVEN DEN C LOW	Watermark density level (Cyan LOW)	0 - 255	19	
	E	WOVEN DEN C MIDDLE	Watermark density level (Cyan MIDDLE)	0 - 255	23	
	F	WOVEN DEN C HIGH	Watermark density level (Cyan HIGH)	0 - 255	27	
	G	WOVEN DEN M LOW	Watermark density level (Magenta LOW)	0 - 255	15	
	H	WOVEN DEN M MIDDLE	Watermark density level (Magenta MIDDLE)	0 - 255	18	
	I	WOVEN DEN M HIGH	Watermark density level (Magenta HIGH)	0 - 255	21	
	J	CONTRAST	Contrast adjustment	0 - 255	2	
K	HT TYPE (POSI)	For half-tone index watermark type positive	42 - 43	42	<p>To reproduce the containing characters of watermark copy (secondary output) more clearly, set to 43.</p> <p>In that case, however, the containing characters of the watermark document (primary output) can be easily reproduced.</p>	
L	HT TYPE (NEGA)	For half-tone index watermark type negative	42 - 43	42	<p>To reproduce the containing characters of watermark copy (secondary output) more clearly, set to 43.</p> <p>In that case, however, the containing characters of the watermark document (primary output) can be easily reproduced.</p>	

Item/Display		Content		Setting range	Default value	Note		
COPY MODE	A	TEXT/PRINTED PHOTO	Text/Printed Photo mode select Enable/Disable	OFF ON	0 - 1 0 1	1	Normally set to the default. No need to change in the market.	
	B	TEXT	Text mode select Enable/Disable	OFF ON	0 - 1 0 1	1		
	C	PRINTED PHOTO	Printed Photo mode select Enable/Disable	OFF ON	0 - 1 0 1	1		
	D	PHOTOGRAPH	Photograph mode select Enable/Disable	OFF ON	0 - 1 0 1	1		
	E	TEXT/PHOTO	Text/Photograph mode select Enable/Disable	OFF ON	0 - 1 0 1	1		
	F	MAP	Map mode select Enable/Disable	OFF ON	0 - 1 0 1	1		
	G	LIGHT	Light density document mode select Enable/Disable	OFF ON	0 - 1 0 1	1		
	H	TEXT/PRINTED PHOTO (CPY TO CPY)	Copy document: Text/Printed Photo mode select Enable/Disable	OFF ON	0 - 1 0 1	1		
	I	TEXT (CPY TO CPY)	Copy document: Text mode select Enable/Disable	OFF ON	0 - 1 0 1	1		
	J	PRINTED PHOTO (CPY TO CPY)	Copy document: Printed Photo mode select Enable/Disable	OFF ON	0 - 1 0 1	1		
	K	AUTO	Automatic mode select Enable/Disable	OFF ON	0 - 1 0 1	1		
	L	DEFAULT MODE	Default exposure mode Used to specify the exposure mode set when the watermark is ON.	TEXT/ PRINTED PHOTO TEXT PRINTED PHOTO PHOTOGRAPH TEXT/PHOTO MAP	0 - 5 0 1 2 3 4 5	0 0 0 0 0 0		0
	POSITION	A	LINE SPACE 1	Line space in the watermark print box (24P - 36P)		0 - 200		20
B		LINE SPACE 2	Line space in the watermark print box (37P - 48P)		0 - 200	20		
C		LINE SPACE 3	Line space in the watermark print box (49P - 64P)		0 - 200	20		
D		LINE SPACE 4	Line space in the watermark print box (65P - 80P)		0 - 200	20		
E		BLANK H/B 1	Upper margin/Lower margin in the watermark print box (24P - 36P)		0 - 200	10		
F		BLANK H/B 2	Upper margin/Lower margin in the watermark print box (37P - 48P)		0 - 200	10		
G		BLANK H/B 3	Upper margin/Lower margin in the watermark print box (49P - 64P)		0 - 200	10		
H		BLANK H/B 4	Upper margin/Lower margin in the watermark print box (65P - 80P)		0 - 200	10		
I		BLANK L/R 1	Left margin/Right margin in the watermark print box (24P - 36P)		0 - 200	60		
J		BLANK L/R 2	Left margin/Right margin in the watermark print box (37P - 48P)		0 - 200	90		
K		BLANK L/R 3	Left margin/Right margin in the watermark print box (49P - 64P)		0 - 200	120		
L		BLANK L/R 4	Left margin/Right margin in the watermark print box (65P - 80P)		0 - 200	150		

46-74

<b>Purpose</b>	Adjustment
<b>Function (Purpose)</b>	Copy color balance adjustment (Auto adjustment)/Printer color balance adjustment (Auto adjustment)

**Section****Operation/Procedure**

This simulation is used to perform SIM46-24 and SIM67-24 continuously.

To perform both the copy color balance adjustment (Automatic adjustment) and the printer color balance adjustment (Automatic adjustment), use this simulation for efficient adjustment operations.

- 1) Press [EXECUTE] key, and the high density process control is performed. Then, the copy color balance adjustment pattern is printed.
- 2) Place the printed adjustment pattern on the document table, select [FACTORY] or [SERVICE] mode.
- 3) Press [EXECUTE] key, and the copy color balance adjustment is performed and the adjustment result pattern is printed.
- 4) Press [EXECUTE] key, and the printer color balance adjustment pattern is printed.
- 5) Place the printed adjustment pattern on the document table, select [FACTORY] or [SERVICE] mode.
- 6) Press [EXECUTE] key, and the printer color balance adjustment (automatic adjustment) is performed and the adjustment result pattern is printed.
- 7) Press [OK] key, and the halftone correction target is registered.
- 8) When [EXECUTE] key is displayed, press it.

When "COMPLETED THIS PROCEDURE" is displayed, the adjustment is completed.

**Important**

The adjustment result becomes effective only when the adjustment procedure for both copy and print mode have completed successfully. For example, when the copy color balance adjustment (automatic adjustment) is performed and the simulation is canceled, the adjustment result is not effective.

46-90

<b>Purpose</b>	Adjustment
<b>Function (Purpose)</b>	Used to set the process operation of high-compression PDF images. (26cpm/36cpm/31cpm(A) machine)

**Section****Operation/Procedure**

- 1) Select a target adjustment mode.
- 2) Select an adjustment target item with the scroll key.
- 3) Enter the set value with 10-key.
- 4) Press [OK] key. The set value is saved.

Mode	Item/Display	Content	Setting range	Default value	
TEXT	A	GLYPH SENSITIVITY	Text handling selection	0 - 2	0
	B	BG SW FOR FINDLINES	Line handling selection	0 - 1	0
	C	HOR FINDLINES SW	Line detection SW (H)	0 - 2	0
	D	VERT FINDLINES SW	Line detection SW (V)	0 - 2	0
	E	FGCOLOR INDEXING SEL	Text color number adjustment SW	0 - 3	0
	F	FGCOLOR INDEXING ADJ	Text color adjustment	0 - 4	2
COLOR	A	LUMINANCE ADJUSTMENT	Luminance adjustment	0 - 4	2
	B	CHROMA INTENT	Chroma selection	0 - 2	1
	C	NEUTRAL ADJUSTMENT	Neutral adjustment	0-2	0
	D	R-RATIO ADJUSTMENT	Gray scale adjustment (R)	0-1000	299
	E	G-RATIO ADJUSTMENT	Gray scale adjustment (G)	0-1000	587
BG LAYER	A	BG LAYER INTENT 1	Speed priority setting	0 - 2	1
	B	BG LAYER INTENT 2	Image quality priority setting	0 - 2	1

46-91

<b>Purpose</b>	Adjustment
<b>Function (Purpose)</b>	Used to adjust the reproduction capability of black text. (26cpm/36cpm/31cpm(A) machine)

**Section****Operation/Procedure**

- 1) Select an item to be set with the scroll key.
  - 2) Enter the set value with 10-key.
  - 3) Press [OK] key.
- The adjustment value is set.

When COLOR key or MONO key is pressed, the adjustment value is set and a copy is made simultaneously.

Item	Display		Content	Description	Setting range	Default value
A	SEGMENT PARAM	COMMON	Area separation setting select	0: Other than image send mode black text emphasis (simple, high compression) 1: Image send mode black text emphasis (simple, high compression)	0 - 1	0
		SPECIAL				
B	BG: JPEG QUALITY LV [COL: COMPACT]		JPEG recompression level adjustment [Color: High compression mode]	The JPEG compression ratio of the background layer is selected. 0: Low 1: Middle 2: High	0 - 2	1
C	BG: JPEG QUALITY LV [COL: ULTRA FINE]		JPEG recompression level adjustment [Color: Ultra fine mode]		0 - 2	1
D	BG: JPEG QUALITY LV [GRY: COMPACT]		JPEG recompression level adjustment [Gray: High compression mode]		0 - 2	1
E	BG: JPEG QUALITY LV [GRY: ULTRA FINE]		JPEG recompression level adjustment [Gray: Ultra fine mode]		0 - 2	1
F	FG: TARGET AREA	TYPE0	Front ground extraction area select		0: type0	0 - 2
		TYPE1		1: type1		
		TYPE2		2: type2		
G	FG: TEXT DENSITY [COL]		Front ground black text density adjustment [Color]	The black text density in the front ground layer is changed.	0 - 10	5
H	FG: TEXT DENSITY [GRY]		Front ground black text density adjustment [Gray]	0: Dark - 5: Default - 10: Light	0 - 10	5
I	ULTRA FINE MODE	OFF	High compression/Ultra Fine mode select	0: High compression mode 1: Ultra fine mode	0 - 1	0

### Note

This must be set to the default unless any change is specially required.  
When the adjustment value is changed greatly from the initial value, an image quality trouble may occur.

## 48

48-1

<b>Purpose</b>	Adjustment
<b>Function (Purpose)</b>	Used to adjust the scan image magnification ratio (in the main scanning direction and the sub scanning direction).

### Section

#### Operation/Procedure

- 1) Select a target adjustment item with scroll key on the touch panel.
- 2) Enter the set value with 10-key.
- 3) Press [OK] key.  
The set value is saved.

When the adjustment value is increased, the image magnification ratio is increased.

A change of "1" in the adjustment value of item A, C, or E corresponds to a change of about 0.02% in the copy magnification ratio.  
A change of "1" in the adjustment value of item B, D, or F corresponds to a change of about 0.1% in the copy magnification ratio.

#### [RSPF]

Item/Display	Content	Setting range	Default value
A	CCD (MAIN) SCAN main scanning magnification ratio adjustment (CCD)	1 - 99	50
B	CCD (SUB) SCAN sub scanning magnification ratio adjustment (CCD)	1 - 99	50
C	SPF (MAIN) RSPF document front surface magnification ratio adjustment (Main scan)	1 - 99	50
D	SPF (SUB) RSPF document front surface magnification ratio adjustment (Sub scan)	1 - 99	50
E	SPFB (MAIN) RSPF document back surface magnification ratio adjustment (Main scan)	1 - 99	50

Item/Display	Content	Setting range	Default value
F	SPFB (SUB) RSPF document back surface magnification ratio adjustment (Sub scan)	1 - 99	50

48-5

<b>Purpose</b>	Adjustment
<b>Function (Purpose)</b>	Used to correction the scan image magnification ratio (in the sub scanning direction).
<b>Section</b>	Scanner section

#### Operation/Procedure

- 1) Select a target adjustment item with scroll key on the touch panel.
- 2) Enter the set value with 10-key.
- 3) Press [OK] key.  
The set value is saved.

When the image magnification ratio in the sub scanning direction is adjusted with SIM48-1, and a different magnification ratio is specified, and the image magnification ratio is not satisfactory, perform this adjustment.

When there is an error in the image magnification ratio in reduction, change the adjustment value in the high speed mode. When there is an error in the image magnification ratio in enlargement, change the adjustment value in the low speed mode.

Item/Display	Content	Setting range	Default value
A	MR (HI) Scanner motor (High speed)	1 - 99	50
B	MR(MID) Scanner motor (Reference speed)	1 - 99	50
C	MR(LO) Scanner motor (Low speed)	1 - 99	50
D	SPF(HI) Document feed (SPF) motor (High speed)	1 - 99	50
E	SPF(MID) Document feed (SPF) motor (Reference speed)	1 - 99	50

48-6

<b>Purpose</b>	Adjustment
<b>Function (Purpose)</b>	Used to adjust the rotation speed of each motor.

**Section****Operation/Procedure**

- 1) Select an adjustment target mode with [COLOR] [MONO] [HEAVY] keys on the touch panel.
- 2) Select a target adjustment item with scroll key on the touch panel.
- 3) Enter the set value with 10-key.
- 4) Press [OK] key.

The set value is saved.

When the adjustment value is increased, the speed is increased, and vice versa. A change of 1 in the adjustment value corresponds to a change of about 0.1% in the speed.

**18cpm/20cpm/23cpm/26cpm/31cpm machine**

Mode Select	Item/Display	Content	Setting range	Default value
COLOR MONO HEAVY	A RRM	Registration motor correction value (23cpm machine only)	1 - 99	51
COLOR MONO HEAVY	B DVM_K	Developing K motor correction value	1 - 99	45
COLOR** HEAVY	C FSM	Fusing motor correction value	1 - 99	38*1 44*2 41
COLOR HEAVY	D DVM_CL	Developing CL motor correction value	1 - 99	45
COLOR*	E PFM	Paper transport motor correction value (23cpm machine only)	1 - 99	48
COLOR*	F POM	Paper exit motor correction value	1 - 99	50
HEAVY	E FUSER SETTING	Fusing speed select timing (23 cpm machine only)	1 - 99	60
HEAVY	F RRM START	Registration motor speed increasing start timing	0 - 255	109
HEAVY	G RRM END	Registration motor speed increasing end timing	0 - 255	210

\* Common items for color, monochrome, and heavy paper

\*\* Common items for color and monochrome

The greater the correction value is, the higher the speed is, and vice versa. Change by  $\pm 1$  corresponds to 0.1%.

\*1: In the case of 20cpm machine

\*2: In the case of 23cpm machine

**36cpm machine**

Mode	Item/Display	Content	Setting range	Default value
COLOR MONO HEAVY	A RRM	Registration motor correction value	1 - 99	51
COLOR MONO HEAVY	B BTM	Belt motor correction value	1 - 99	47
COLOR MONO HEAVY	C DVM_K	Developing K motor correction value	1 - 99	45
COLOR** HEAVY	D FSM	Fusing motor correction value	1 - 99	Refer to the list below.
COLOR HEAVY	E DVM_CL	Developing CL motor correction value	1 - 99	45

Mode	Item/Display	Content	Setting range	Default value
COLOR*	F PFM	Paper transport motor correction value	1 - 99	48
COLOR*	G POM	Paper exit motor correction value	1 - 99	50
HEAVY	F FUSER SETTING	Fusing speed select timing	1 - 99	60
HEAVY	G RRM START	RPM acceleration start timing	0 - 255	109
HEAVY	H RRM END	RPM acceleration end timing	0 - 255	210

**Default value of FSM**

Item	Default value					
	26cpm/31cpm machine			36cpm machine		
	Group A	Group A	Group B	Group C	Group B	Group C
D	44	44	44	44	44	44

Group	Destination				
Group A	JAPAN	AB_B	CHINA		
Group B	U. S. A	CANADA	INCH		
Group C	EUROPE	U. K	AUS.	AB_A	

**Important**

This must be set to the default unless any change is specially required.

When the adjustment value is set to a value greatly different from the default value, a jam, paper wrinkle, or image quality trouble may occur.

**49**

49-1

<b>Purpose</b>	
<b>Function (Purpose)</b>	Used to perform the firmware update.
<b>Section</b>	

**Operation/Procedure**

- 1) Save the firmware to the USB memory.
- 2) Insert the USB memory into the main unit. (Use USB I/F of the operation panel section.)
- 3) Select a target firmware file for update with the touch panel.
- 4) Select a target firmware.  
Press [ALL] key to select all the Firmware collectively.
- 5) Press [EXECUTE] key.
- 6) Press [YES] key.

The selected firmware is updated.

When the operation is normally completed, "COMPLETE" is displayed. When terminated abnormally, "ERROR" is displayed.

**18cpm/20cpm/23cpm/31cpm(G) machine**

Item/Display	Content	Error display in case of abnormality
CONFIG	Configuration data	CONF
ICU (MAIN)	ICU Main section	ICUM
ICU (BOOTM)	ICU Boot section main	ICUBM
ICU (BOOTCN)	ICU Boot section CN	ICUCN
ICU (SUB)	ICU Sub section (ARM9)	ICUS
LANGUAGE	Language support data program	LANG
GRAPHIC	Graphic data for L-LCD	GRAPH
SLIST	SLIST data for L-LCD	SLIST
PCL (BOOT)	PCL Boot section	PCLB
PCL (MAIN)	PCL Main section	PCLM

Item/Display	Content	Error display in case of abnormality
PCL (CONFIG)	PCL Configuration data	PCLC
PCL (PROFILE)	PCL Color profile	PCLP
PCU (BOOT)	PCU Boot section	PCUB
PCU (MAIN)	PCU Main section	PCUM
DESK (BOOT)	Desk unit boot section	DESKB
DESK (MAIN)	Desk unit main section	DESKM
FIN (BOOT)	Inner finisher boot section	FINB
FIN (MAIN)	Inner finisher main section	FINM
SCU (BOOT)	SCU Boot section	SCUB
SCU (MAIN)	SCU Main section	SCUM
FAX (BOOT)	FAX1 Boot section	FAXB
FAX (MAIN)	FAX1 Main section	FAXM
ANIMATION	Animation data	ANIME
WEB HELP	WEB help	WEBHP

### 26cpm/36cpm/31cpm(A) machine

Item/Display	Content	Error display in case of abnormality
CONFIG	Configuration data	CONF
ICU (MAIN)	ICU Main section	ICUM
ICU (BOOTM)	ICU Boot section main	ICUBM
ICU (BOOTCN)	ICU Boot section CN	ICUCN
ICU (SUB)	ICU Sub section (ARM9)	ICUS
LANGUAGE	Language support data program	LANG
GRAPHIC	Graphic data for L-LCD	GRAPH
UICONTENTS	Content data for display	UICON
SLIST	SLIST data for L-LCD	SLIST
EOSA	embedded OSA	EOSA
PCL (BOOT)	PCL Boot section	PCLB
PCL (MAIN)	PCL Main section	PCLM
PCL (CONFIG)	PCL Configuration data	PCLC
PCL (PROFILE)	PCL Color profile	PCLP
PCU (BOOT)	PCU Boot section	PCUB
PCU (MAIN)	PCU Main section	PCUM
DESK (BOOT)	Desk unit boot section	DESKB
DESK (MAIN)	Desk unit main section	DESKM
A4LCC (BOOT)	LCC Boot	LCC4B
A4LCC (MAIN)	LCC Main	LCC4M
FIN (BOOT)	Inner finisher boot section	FINB
FIN (MAIN)	Inner finisher main section	FINM
1KFIN (BOOT)	Saddle stitch finisher Boot	FIN1B
1KFIN (MAIN)	Saddle stitch finisher Main	FIN1M
1KPUNCH (BOOT)	Saddle punch unit Boot	1PUNB
1KPUNCH (MAIN)	Saddle punch unit Main	1PUNM
SCU (BOOT)	SCU Boot section	SCUB
SCU (MAIN)	SCU Main section	SCUM
FAXOPT1 (BOOT)	FAX1 Boot section	FXO1B
FAXOPT1 (MAIN)	FAX1 Main section	FXO1M
PDL_FONT	PDL font	PDL
ANIMATION	Animation data	ANIME
WEB HELP	WEB help	WEBHP
ACRE (BOOT)	Enhanced compression kit Boot	ACREB
ACRE (MAIN)	Enhanced compression kit Main	ACREM
ACRE_DATA	Enhanced compression kit Table	ACRED

### List of error displays in case of abnormal end

Item/Display	Content
CONF	Configuration data
ICUM	ICU Main section former half
ICUBM	ICU Boot section main
ICUCN	ICU Boot section CN
LANG	Language support data program (General term)
GRAPH	Graphic data for L-LCD
SLIST	SLIST data for L-LCD
PCUB	PCU Boot section
PCUM	PCU Main section

Item/Display	Content
DESKB	Desk unit BOOT section
DESKM	Desk unit MAIN section
LCC4B	Side LCC (A4) Boot section
LCC4M	Side LCC (A4) main section
FINB	Inner finisher BOOT section
FINM	Inner finisher MAIN section
FIN1B	1K finisher Boot section
FIN1M	1K finisher Main section
FIN4B	4K finisher Boot section
FIN4M	4K finisher Main section
1PUNB	Punch unit Boot section for 1K finisher
1PUNM	Punch unit Main section for 1K finisher
4PUNB	Punch unit Boot section for 4K finisher
4PUNM	Punch unit Main section for 4K finisher
SCUB	SCU Boot section
SCUM	SCU Main section
FAXB	FAX1 Boot section
FAXM	FAX1 Main section
FXOPB	FAX2 Boot section (Japan only)
FXOPM	FAX2 Main section (Japan only)
ESCP	ESC/P font
PDL	PDL font
ANIME	Animation data
IMGDT	Image ASIC data
CORP	Color profile
WEBHP	WEB help
UNICD	UNICODE table
UICON	Content data for display

### 49-3

#### Purpose

#### Function (Purpose)

Used to update the operation manual in the HDD.

#### Section

#### Operation/Procedure

- 1) Insert the USB memory into the main unit.
  - \* When the USB is not inserted, "INSERT A STORAGE E-MANUAL STORED ON" is displayed. When [OK] key is pressed, the display is shifted to the folder select menu 1.
- 2) Press the folder button of the operation manual data. (The display is shifted to the operation manual update menu.)  
The current version and the update version are displayed.
- 3) Press [EXECUTE] key.  
[EXECUTE] key is highlighted, and [YES] [NO] keys becomes active from gray out.
- 4) When [YES] key is pressed, the selected operation manual is updated.  
When update is completed normally, "COMPLETE" is displayed. When terminated abnormally, "ERROR" is displayed.

### 49-5

#### Purpose

#### Function (Purpose)

Used to perform the watermark update.

#### Section

#### Operation/Procedure

- 1) Insert the USB memory into the main unit.
- 2) Select the button of the folder to perform the watermark update.
- 3) The current version and the update version are displayed.
- 4) Press [EXECUTE] key.
- 5) Press [YES] key.  
The selected watermark is updated.

50-1

**Purpose** Adjustment

**Function (Purpose)** Copy image position, image loss adjustment

**Section**

**Operation/Procedure**

- 1) Select an adjustment target item with scroll key on the touch panel.
- 2) Enter the set value with 10-key.  
Set the items other than RRCA, LEAD, and SIDE to the default.  
RRCA: Image lead edge reference position adjustment  
LEAD: Lead edge image loss adjustment  
SIDE: Side image loss adjustment
- 3) Press [OK] key. (The set value is saved.)

Item/Display	Content	Setting range	Default value			
A	Lead edge adjustment value	RRCA	Document lead edge reference position (OC)	0 - 99	50	
B	Image loss area setting value	RRCB-CS1	Registration motor ON timing adjustment	Standard Tray	1 - 99	60
C		RRCB-DSK	Desk	1 - 99	60	
D		RRCB-LCC	LCC	1 - 99	60	
E		RRCB-MFT	Manual paper feed	1 - 99	60	
F		RRCB-ADU	ADU	1 - 99	60	
G	Image loss area setting value	LEAD	Lead edge image loss area setting	0 - 99	40	
H		SIDE	Side image loss area adjustment	0 - 99	20	
I	Void area adjustment	DENA	Lead edge void area adjustment	1 - 99	40	
J		DENB	Rear edge void area adjustment	1 - 99	30	
K		FRONT/REAR	FRONT/REAR void area adjustment	1 - 99	20	
L	Off-center adjustment	OFFSET_OC	OC document off-center adjustment	1 - 99	50	
M	Magnification ratio correction	SCAN_SPEED_OC	SCAN sub scanning magnification ratio adjustment (CCD)	1 - 99	50	
N	Sub scanning direction print area correction value	DENB-MFT	Manual feed correction value	1 - 99	50	
O		DENB-CS1	Tray 1 correction value	1 - 99	50	
P		DENB-CS2	Tray 2 correction value	1 - 99	50	
Q		DENB-CS3	Tray 3 correction value	1 - 99	50	
R		DENB-CS4	Tray 4 correction value	1 - 99	50	
S		DENB-LCC	LCC correction value	1 - 99	50	
T		DENB-ADU	ADU correction value	1 - 99	50	
U		DENB-HV	Heavy paper correction value	1 - 99	50	

- A. (RRC-A) Timing from starting document scanning to specifying the image lead edge reference is adjusted. (0.1mm/step)
  - \* When the value is decreased, the timing is advanced. When the value is increased, the timing is delayed.
- B - F. (RRC-B) Timing of paper (registration roller ON) for the image position on the transfer belt is adjusted. (0.1mm/step)
  - \* When the value is decreased, the timing is delayed. When the value is increased, the timing is advanced.
- G. (LEAD) The lead edge image loss amount is adjusted. (0.1mm/step)
  - \* When the value is increased, the image loss is increased.
- H. (SIDE) The side image loss amount is adjusted.
  - \* When the value is increased, the image loss is increased. (0.1mm/step)
- I. (DEN-A) The paper lead edge void amount is adjusted. (0.1mm/step)
  - \* When the value is increased, the void is increased.
- J. (DEN-B) The paper rear edge void amount is adjusted. (0.1mm/step)
  - \* When the value is increased, the void is increased.
- K. (FRONT/REAR) The void amount on the right and left edges of paper is adjusted. (0.1mm/step)

50-2

**Purpose** Adjustment

**Function (Purpose)** Used to adjust the copy image position and the image loss. (This simulation is a simplified version of SIM 50-1.) (18cpm/20cpm/23cpm/31cpm(G) machine)

**Section**

**Operation/Procedure**

- 1) Set item A (L1) and item B (L2) to 0.
- 2) Place a rule on the left edge of the document table, and make a copy at a magnification ratio of 400%.
- 3) Measure the length of L1 and L2 on the copied image in the unit of 0.1mm (referring to the figure below). Enter the adjustment values of L1 x 10 and L2 x 10. Be sure to enter the both adjustment values of L1 and L2.  
L1: Distance from the lead edge of the copied image to 10mm scale.  
L2: Distance from the paper lead edge to the copy image lead edge.

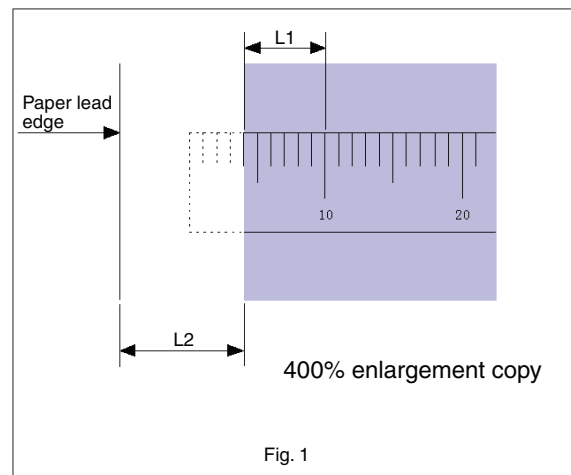

Fig. 1



- 4) Press [EXECUTE] key. (The set value is saved.)
- 5) Make a copy at the magnification ratio of 100%, and adjust the rear edge void.

Item/Display			Description	Setting range	Default value
A	Actual measurement value	L1	Distance from the image lead edge to the scale of 10mm. (Platen 400%, 0.1mm increment)	0 - 999	-
B		L2	Distance from the paper lead edge to the image lead edge (0.1mm increment)	0 - 999	0
C	Image loss area setting value	LEAD	Lead edge image loss amount setting (When the adjustment value is increased, the image loss is increased.)	0 - 99	40
D		SIDE	Side edge image loss amount setting (When the adjustment value is increased, the image loss is increased.)	0 - 99	20
E	Void area adjustment	DENA	Lead edge void area adjustment (When the adjustment value is increased, the void is increased.)	1 - 99	40
F		DENB	Rear edge void area adjustment (When the adjustment value is increased, the void is increased.)	1 - 99	30
G		FRONT/ REAR	FRONT/REAR void amount adjustment (When the adjustment value is increased, the void is increased.)	1 - 99	20

Same as the adjusted items of SIM50-01 except for A and B.

The values adjusted with A and B are reflected to the document lead edge reference position (RRC-A) of SIM50-01 and all the paper lead edge positions (RRCB-\*\*).

All adjustment items: 1 step = 0.1mm change

<b>Purpose</b>	Adjustment
<b>Function (Purpose)</b>	Used to adjust the print lead edge image position. (PRINTER MODE)

**Section****Operation/Procedure**

- 1) Select a target adjustment item (DEN-C) with scroll key on the touch panel.
- 2) Enter the adjustment value using the 10-key.
- 3) Press [EXECUTE] key.  
The set value is saved, and the adjustment check pattern is printed.
- 4) Measure the distance from the paper lead edge the adjustment pattern to the image lead edge, and check to confirm that it is in the standard adjustment value range.

Standard reference value: 4.0±2.0mm

When the adjustment value is increased, the distance from the paper lead edge to the image lead edge is increased. When the adjustment value is decreased, the distanced is decreased.

When the set value is changed by 1, the distance is changed by about 0.1mm.

Item/Display		Content		Setting range	Default value	NOTE	
A	DEN-C	Used to adjust the print lead edge image position. (PRINTER MODE)		1 - 99	30	Adjustment value too align the print lead edge for the printer. When the adjustment value of this item is decreased by 1, the printer print start position in the paper transport direction is shifted to the lead edge by 0.1mm.	
B	DEN-B	Rear edge void area adjustment		1 - 99	30	Void amount generated at the paper rear edge. When the adjustment value of item B (DEN-B) is decreased by 1, the print area adjustment value in the sub scanning direction for the paper transport direction is decreased by 0.1mm.	
C	FRONT/REAR	FRONT/REAR void area adjustment		1 - 99	20	Adjustment of the void amount generated on the left and right edges of paper. When the adjustment value is increased, the void amount is increased.	
D	DENB-MFT	Manual feed rear edge void area adjustment correction value		1 - 99	50	Fine adjustment value of each paper feed source for the adjustment value of DEN-B	
E	DENB-CS1	Tray 1 rear edge void area adjustment correction value		1 - 99	50		
F	DENB-CS2	Tray 2 rear edge void area adjustment correction value		1 - 99	50		
G	DENB-CS3	Tray 3 rear edge void area adjustment correction value		1 - 99	50		
H	DENB-CS4	Tray 4 rear edge void area adjustment correction value		1 - 99	50		
I	DENB-LCC	LCC rear edge void aria adjustment correction value		1 - 99	50		
J	DENB-ADU	ADU rear edge void aria adjustment correction value		1 - 99	55		
K	DENB-HV	Heavy paper correction value		1 - 99	50		
L	MULTI COUNT	Number of print		1 - 999	1	Adjustment pattern print conditions setting	
M	PAPER	MFT	Tray selection	Manual paper feed	1 - 6	1	2 (CS1)
		CS1				2	
		CS2				3	
		CS3				4	
		CS4				5	
		LCC				6	
N	DUPLEX	YES	Duplex print selection	Yes	0 - 1	0	1 (NO)
		NO				No	

When the adjustment value is increased, the distance from the paper lead edge to the image lead edge is increased. When the adjustment value is decreased, the distance from the paper lead edge to the image lead edge is decreased.

When the set value is changed by 1, the distance is changed by about 0.1mm.

50-6

<b>Purpose</b>	Adjustment
<b>Function (Purpose)</b>	Used to adjust the copy image position and the image loss. (RSPF mode)
<b>Section</b>	RSPF

**Operation/Procedure**

- 1) Select an adjustment target item with scroll key on the touch panel.
- 2) Enter the set value with 10-key.
- 3) Press [OK] key. (The set value is saved.)

**[RSPF]**

	Item/Display	Content	Setting range	Default value
A	SIDE1	Front surface document scan position adjustment (CCD)	1 - 99	50
B	SIDE2	Back surface document scan position adjustment (CCD)	1 - 99	50
C	Image loss amount setting SIDE1	LEAD_EDGE (SIDE1) Front surface lead edge image loss amount setting	0 - 99	20
D	Image loss amount setting SIDE1	FRONT_REAR (SIDE1) Front surface side image loss amount setting	0 - 99	20
E	Image loss amount setting SIDE1	TRAIL_EDGE (SIDE1) Front surface rear edge image loss amount setting	0 - 99	40
F	Image loss amount setting SIDE2	LEAD_EDGE (SIDE2) Back surface lead edge image loss amount setting	0 - 99	20
G	Image loss amount setting SIDE2	FRONT_REAR (SIDE2) Back surface side image loss amount setting	0 - 99	20
H	Image loss amount setting SIDE2	TRAIL_EDGE (SIDE2) Back surface rear edge image loss amount setting	0 - 99	40
I	OFFSET_SPF1	SPF front surface document off-center adjustment	1 - 99	50
J	OFFSET_SPF2	SPF back surface document off-center adjustment	1 - 99	50
K	SCAN_SPEED_SPF1	RSPF document front surface magnification ratio (Sub scan)	1 - 99	50
L	SCAN_SPEED_SPF2	RSPF document back surface magnification ratio (Sub scan)	1 - 99	50

Item A, B: When the adjustment value is increased, the scan timing is delayed.

Item C - H: When the adjustment value is increased, the image loss is increased.

Item E - H: When a shadow image appears on the rear edge, increase the adjustment value to delete the shadow.

All adjustment items: 1 step = 0.1mm change

50-7

<b>Purpose</b>	Adjustment
<b>Function (Purpose)</b>	Used to adjust the copy image position and the image loss (RSPF mode). (This simulation is a simplified version of SIM 50-6.) (18cpm/20cpm/23cpm/31cpm(G) machine)
<b>Section</b>	RSPF

**Operation/Procedure**

- 1) Select an adjustment target item with scroll key on the touch panel.
- 2) Set item A (L4) and item B (L5) to 0.
- 3) Set the magnification ratio to 200%, and make a copy in the RSPF duplex mode.
- 4) Measure the size of the printed image. Enter the actual measurement value of distance a (RSPF) to L4 and L5 in the unit of 0.1mm.

(Adjustment value "1" for 0.1mm)

L4: Distance a (RSPF front surface: 200%) (unit: 0.1mm)

L5: Distance a (RSPF back surface: 200%) (unit: 0.1mm)

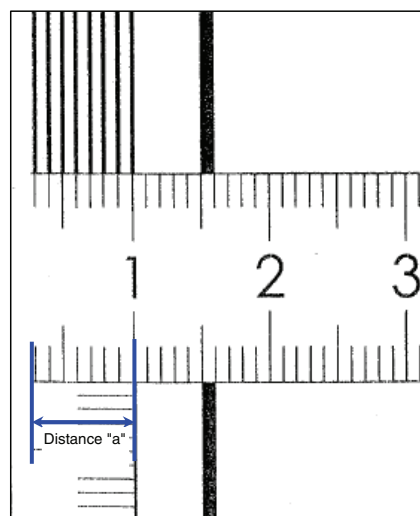

- 5) Press [EXECUTE] key. (The set value is saved.)

**[RSPF]**

	Item/Display	Content	Setting range	Default value
A	L4	Distance (SPF 200%, 0.1mm unit) from the front surface image lead edge to the scale of 10mm.	0 - 999	-
B	L5	Distance (SPF 200%, 0.1mm unit) from the back surface image lead edge to the scale of 10mm.	0 - 999	-
C	LEAD_EDGE (SIDE1)	Front surface lead edge image loss amount setting	0 - 99	20
D	FRONT_REAR (SIDE1)	Front surface side image loss amount setting	0 - 99	20
E	TRAIL_EDGE (SIDE1)	Front surface rear edge image loss amount setting	0 - 99	40
F	LEAD_EDGE (SIDE2)	Back surface lead edge image loss amount setting	0 - 99	20
G	FRONT_REAR (SIDE2)	Back surface side image loss amount setting	0 - 99	20
H	TRAIL_EDGE (SIDE2)	Back surface rear edge image loss amount setting	0 - 99	40

Item C - H: When the adjustment value is increased, the image loss is increased.

All adjustment items: 1 step = 0.1mm change

Items C - H are linked with items C - H of SIM50-06.

50-10

<b>Purpose</b>	Adjustment
<b>Function (Purpose)</b>	Used to adjust the black print image magnification ratio and the off-center position. (The adjustment is made separately for each paper feed section.)
<b>Section</b>	

**Operation/Procedure**

- 1) Select an adjustment target item with scroll key on the touch panel.
- 2) Enter the set value with 10-key.
- 3) Press [EXECUTE] key. (The set value is saved.)

Item/Display	Content	Setting range	Default value	NOTE			
A BK-MAG	Main scan print magnification ratio BK	60 - 140	110	Adjustment Item List			
B MAIN-MFT	Print off center adjustment value (Manual paper feed)	1 - 99	50				
C MAIN-CS1	Print off center adjustment value (Tray 1)	1 - 99	52				
D MAIN-CS2	Print off center adjustment value (Tray 2)	1 - 99	52				
E MAIN-CS3	Print off center adjustment value (Tray 3)	1 - 99	52				
F MAIN-CS4	Print off center adjustment value (Tray 4)	1 - 99	52				
G MAIN-LCC	Print off center adjustment value (Large capacity tray)	1 - 99	52				
H MAIN-ADU	Print off center adjustment value (Duplex) <b>Important</b> If the adjustment items A - G are not properly adjusted, this adjustment cannot be executed properly.	1 - 99	42	Adjustment Item List			
I SUB-MFT	Registration motor ON timing adjustment	Manual paper feed	1 - 99		60		
J SUB-CS1		Standard cassette	1 - 99		60		
K SUB-DSK		DESK	1 - 99		60		
L SUB-LCC		LCC	1 - 99		60		
M SUB-ADU		ADU	1 - 99		60		
N MULTI COUNT	Number of print	1 - 999	1	Adjustment pattern print conditions setting			
O PAPER	MFT CS1 CS2 CS3 CS4 LCC	Tray selection	Manual paper feed		1 - 6	1	2 (CS1)
			Tray 1			2	
			Tray 2			3	
			Tray 3			4	
			Tray 4			5	
			LCC			6	
P DUPLEX	YES NO	Duplex print selection	Yes	0 - 1	0	1 (NO)	
			No		1		

Item A: When the set value is increased, the BK image magnification ratio in the main scanning direction is increased. When the set value is decreased, the image magnification ratio is decreased.

Item B - H: When the adjustment value is increased, it is shifted to the front frame side. When the adjustment value is decreased, it is shifted to the rear frame side.

All adjustment items: 1 step = 0.1mm change

50-12

<b>Purpose</b>	Adjustment
<b>Function (Purpose)</b>	Used to perform the scan image off-center position adjustment. (The adjustment is made separately for each scan mode.)
<b>Section</b>	

**Operation/Procedure**

- 1) Select an adjustment target item with scroll key on the touch panel.
- 2) Enter the set value with 10-key.
- 3) Press [OK] key. (The set value is saved.)

When the adjustment value is increased, the image position is shifted to the rear frame side. When the adjustment value is decreased, it is shifted to the front frame side.

1step = 0.1mm

Item/Display	Content	Setting range	Default value
A OC	Document table image off-center adjustment	1 - 99	50
B SPF (SIDE1)	SPF front surface image off-center adjustment	1 - 99	50
C SPF (SIDE2)	SPF back surface image off-center adjustment	1 - 99	50

<b>Purpose</b>	Adjustment
<b>Function (Purpose)</b>	Image registration adjustment (Main scanning direction)

**Section****Operation/Procedure**

- 1) Select an adjustment target item with scroll key on the touch panel.
- 2) Enter the set value with 10-key.
- 3) Press [EXECUTE] key. (The set value is saved.)

Item/Display	Content	Setting range	Default value				
			18cpm/ 20cpm/ 23cpm machine	26cpm/ 31cpm/ 36cpm machine			
A	CYAN(FRONT)	Registration adjustment value main scanning direction CYAN F side	1 - 199	100			
B	CYAN(REAR)	Registration adjustment value main scanning direction CYAN R side	1 - 199	100			
C	MAGENTA(FRONT)	Registration adjustment value main scanning direction MAGENTA F side	1 - 199	100			
D	MAGENTA(REAR)	Registration adjustment value main scanning direction MAGENTA R side	1 - 199	100			
E	YELLOW(FRONT)	Registration adjustment value main scanning direction YELLOW F side	1 - 199	100			
F	YELLOW(REAR)	Registration adjustment value main scanning direction YELLOW R side	1 - 199	100			
G	CYAN(SUB)	Registration adjustment value sub scanning direction CYAN (Black drum reference)	1 - 199	100			
H	MAGENTA(SUB)	Registration adjustment value sub scanning direction MAGENTA (Black drum reference)	1 - 199	100			
I	YELLOW(SUB)	Registration adjustment value sub scanning direction YELLOW (Black drum reference)	1 - 199	100			
J	OFFSET_C_F	Registration adjustment value main scanning direction offset value CYAN (FRONT)	1 - 99	50			
K	OFFSET_C_R	Registration adjustment value main scanning direction offset value CYAN (REAR)	1 - 99	50			
L	OFFSET_M_F	Registration adjustment value main scanning direction offset value MAGENTA (FRONT)	1 - 99	50			
M	OFFSET_M_R	Registration adjustment value main scanning direction offset value MAGENTA (REAR)	1 - 99	50			
N	OFFSET_Y_F	Registration adjustment value main scanning direction offset value YELLOW (FRONT)	1 - 99	50			
O	OFFSET_Y_R	Registration adjustment value main scanning direction offset value YELLOW (REAR)	1 - 99	50			
P	OFFSET_C_S	Registration adjustment value sub scanning direction offset value CYAN	1 - 99	49	50		
Q	OFFSET_M_S	Registration adjustment value sub scanning direction offset value MAGENTA	1 - 99	49	47		
R	OFFSET_Y_S	Registration adjustment value sub scanning direction offset value YELLOW	1 - 99	49	48		
S	MULTICOUNT	Number of print	1 - 999	1			
T	PAPER	MFT	Tray selection	Manual paper feed	1 - 6	1	2 (CS1)
		CS1				2	
		CS2				3	
		CS3				4	
		CS4				5	
		LCC				6	
U	DUPLEX	YES	Duplex print selection	Yes	0 - 1	0	1 (NO)
		NO		No		1	

<b>Purpose</b>	Adjustment
<b>Function (Purpose)</b>	Used to adjust the image registration. (Main scan direction, sub scan direction) (Auto adjustment)/OPC drum phase adjustment (Auto adjustment)

<b>Section</b>
----------------

**Operation/Procedure**

- 1) Press [EXECUTE] key.

The adjustment is automatically performed, and the adjustment data are displayed.

<b>Note</b>
-------------

The contents of the following list are mainly used by the technical division, and are not necessary for the market.

Item/Display		Content	Display	Default value	NOTE	
MAIN F	C	Image registration adjustment value (Main scanning direction) (Position of writing by cyan laser is F side)	1.0 - 199.0	100		
	M	Image registration adjustment value (Main scanning direction) (Position of writing by magenta laser is F side)	1.0 - 199.0	100		
	Y	Image registration adjustment value (Main scanning direction) (Position of writing by yellow laser is F side)	1.0 - 199.0	100		
MAIN R	C	Image registration adjustment value (Main scanning direction) (Position of writing by cyan laser is R side)	1.0 - 199.0	100		
	M	Image registration adjustment value (Main scanning direction) (Position of writing by magenta laser is R side)	1.0 - 199.0	100		
	Y	Image registration adjustment value (Main scanning direction) (Position of writing by yellow laser is R side)	1.0 - 199.0	100		
SUB	C	Image registration adjustment value (Sub scanning direction) (Cyan drum to black drum)	1.0 - 199.0	100		
	M	Image registration adjustment value (Sub scanning direction) (Magenta drum to cyan drum)	1.0 - 199.0	100		
	Y	Image registration adjustment value (Sub scanning direction) (Yellow drum to magenta drum)	1.0 - 199.0	100		
SKEW	C	Calculated result of print skew amount (Cyan)	-99.9 - 99.9	-	If the value is plus, R is displayed to left side of numerical value. If the value is minus, L is displayed to left side of numerical value. When the value is -4 - +4, "(OK)" is place at the back of the value. For the other cases, "(NG)" is displayed. *1	
	M	Calculated result of print skew amount (magenta)	-99.9 - 99.9	-		
	Y	Calculated result of print skew amount (yellow)	-99.9 - 99.9	-		
PHASE	Phase adjustment value BK → CL	Angle step 0°(1) → 45°(2) → 90°(3) → 135°(4) → 180°(5) → 225°(6) → 270°(7) → 315°(8)	1 - 8	2	Same item as SIM44-31.	
	Phase adjustment value C			2		Same item as SIM44-31. (50-sheet machine)
	Phase adjustment value M			4		
	Phase adjustment value Y			5		

Item/Display			Content	Setting range (unit)	Color/History	Default value	NOTE
MAIN F	-	REG_M_F (VALUE)	Registration adjustment correction amount main scanning direction F	1.0 - 199.0 ( $\pm 0.1$ )	CMY/-	100	
	( )	REG_M_F (DIF)	Registration value correction amount from the previous one, main scanning F	-199.0 - 199.0 ( $\pm 0.1$ )	CMY/-	0	
MAIN R	-	REG_M_R (VALUE)	Registration adjustment correction value, main scanning direction R	1.0 - 199.0 ( $\pm 0.1$ )	CMY/-	100	
	( )	REG_M_R (DIF)	Registration value correction amount from the previous one, main scanning R	-199.0 - 199.0 ( $\pm 0.1$ )	CMY/-	0	
SUB	-	REG_SUB (VALUE)	Registration adjustment correction value, sub scanning direction	1.0 - 199.0 ( $\pm 0.1$ )	CMY/-	100	
	( )	REG_SUB (DIF)	Registration value correction amount from the previous one, sub scanning	-199.0 - 199.0 ( $\pm 0.1$ )	CMY/-	0	
SKEW	CMY	SKEW_CLC	SKEW adjustment rotating direction and the number of clicks (CMY)	L99.9 - R99.9 ( $\pm 0.1$ )	KCMY/-	0	If the value is plus, L is displayed to left side of numerical value. If the value is minus, R is displayed to left side of numerical value. When the value is -2.1 - +2.1, "(OK)" is place at the back of the value. For the other cases, "(NG)" is displayed. *1
	ALL_ROTATE		SKEW adjustment rotating direction and the number of clicks (K)				
PHASE		PHASE_ADJ	Phase adjustment value (1: Value of this time, 2: Value of the previous time) Angle step 0° (1) → 45° (2) → 90° (3) → 135° (4) → 180° (5) → 225° (6) → 270° (7) → 315° (8)	1 - 8 ( $\pm 1$ )	-/2	1	-

\*1: The color image skew adjustment is performed according to this display value.

When "R" is displayed in front of the value, turn and click the skew adjustment screw (LSU) clockwise by the value.

When "L" is displayed in front of the value, turn and click the skew adjustment screw (LSU) counterclockwise by the value.

\*2: The color image skew adjustment is performed according to this display value.

When "R" is displayed at the head of the value, turn the skew adjustment screw (LSU) clockwise by the number of the value.

When "L" is displayed at the head of the value, turn the skew adjustment screw (LSU) counterclockwise by the number of the value.

At that time, the values under the decimal point are rounded.

#### Error displays in case of abnormal end

	Error code	Error display	Error content	Description
Forcible end error	-	SUSPENDED	Door open end	Door open during operation
	-	SUSPENDED	CA end	CA button pressed during operation
	-	-	OFF end	Unconfirmed operation during operation (Power OFF)
Basic error	1	TONNER EMPTY	Toner Empty	BK or ALL Color toner EMPTY detection
	2	BEFOR BEHAVIOR	Other condition	Other condition
	4	SENSOR CALIBLATION F	Calibration error F	The target is not reached by 3 times of retry of F or R
	5	SENSOR CALIBLATION R	Calibration error R	
	6	SENSOR CALIBLATION FR	Calibration error FR	
	7	TIME OVER	Time error	No data are obtained for 90sec from data acquisition
8	PROCESS CONTROL	Process control error	Process control error detection	
Sub scanning adjustment error	10 - 47	SUB XXX XXXX XXX		
Main scanning adjustment error	50 - 88	MAIN XXX XXXX XXX		
Others	99	OTHER 99	Other errors	Other errors

50-24

**Purpose** (This simulation is normally not used in the market.)

**Function (Purpose)** Used to display the detail data of SIM 44-2, 50-20, 21 and 22.

**Section**

**Operation/Procedure**

**Note**

This simulation is mainly used by the technical division, and is not necessary for the market.

50-27

**Purpose** Adjustment

**Function (Purpose)** Used to perform the image loss adjustment of scanned images in the FAX or image send mode.

**Section**

**Operation/Procedure**

- 1) Select a target adjustment mode with [FAX] or [SCANNER] key.
- 2) Select an adjustment target item with scroll key on the touch panel.
- 3) Enter the set value with 10-key.
- 4) Press [OK] key. (The set value is saved.)

**[RSPF]**

		Item/Display	Content	Setting range	Default value	
FAX send	A	Image loss amount setting OC	LEAD_EDGE (OC)	OC lead edge image loss amount setting	0 - 100	30 (3mm)
	B		FRONT_REAR (OC)	OC side image loss amount setting	0 - 100	20 (2mm)
	C		TRAIL_EDGE (OC)	OC rear edge image loss amount setting	0 - 100	20 (2mm)
	D	Image loss amount setting SPF SIDE1	LEAD_EDGE (SPF_SIDE1)	Front surface lead edge image loss amount setting	0 - 100	20 (2mm)
	E		FRONT_REAR (SPF_SIDE1)	Front surface side image loss amount setting	0 - 100	20 (2mm)
	F		TRAIL_EDGE (SPF_SIDE1)	Front surface rear edge image loss amount setting	0 - 100	30 (3mm)
	G	Image loss amount setting SPF SIDE2	LEAD_EDGE (SPF_SIDE2)	Back surface lead edge image loss amount setting	0 - 100	20 (2mm)
	H		FRONT_REAR (SPF_SIDE2)	Back surface side image loss amount setting	0 - 100	20 (2mm)
	I		TRAIL_EDGE (SPF_SIDE2)	Back surface rear edge image loss amount setting	0 - 100	30 (3mm)
When image send mode (Except for FAX and copy)	A	Image loss amount setting OC	LEAD_EDGE (OC)	OC lead edge image loss amount setting	0 - 100	0 (0mm)
	B		FRONT_REAR(OC)	OC side image loss amount setting	0 - 100	0 (0mm)
	C		TRAIL_EDGE(OC)	OC rear edge image loss amount setting	0 - 100	0 (0mm)
	D	Image loss amount setting SPF SIDE1	LEAD_EDGE (SPF_SIDE1)	Front surface lead edge image loss amount setting	0 - 100	0 (0mm)
	E		FRONT_REAR (SPF_SIDE1)	Front surface side image loss amount setting	0 - 100	0 (0mm)
	F		TRAIL_EDGE(SPF_SIDE1)	Front surface rear edge image loss amount setting	0 - 100	0 (0mm)
	G	Image loss amount setting SPF SIDE2	LEAD_EDGE (SPF_SIDE2)	Back surface lead edge image loss amount setting	0 - 100	0 (0mm)
	H		FRONT_REAR (SPF_SIDE2)	Back surface side image loss amount setting	0 - 100	0 (0mm)
	I		TRAIL_EDGE(SPF_SIDE2)	Back surface rear edge image loss amount setting	0 - 100	0 (0mm)

A-I: When the adjustment value is increased, the image loss is increased.

1step = 0.1mm



50-28

<b>Purpose</b>	Adjustment
<b>Function (Purpose)</b>	Used to automatically adjust the image loss, void area, image off-center, and image magnification ratio.

**Section****Operation/Procedure**

The following adjustment items can be executed automatically with SIM50-28.

- \* ADJ16 Print image position, image magnification ratio, void area, off-center adjustments (Manual adjustments)
- \* ADJ 17 Scan image magnification ratio adjustment (Manual adjustment)
- \* ADJ 18 Scan image off-center adjustment (Manual adjustment)
- \* ADJ 19 Used to adjust the copy image position and the image loss (Manual adjustments)

- 1) Select an adjustment item with the menu button.
- 2) Press [EXECUTE] key, and the adjustment pattern is printed.
- 3) Set the adjustment pattern on the document table.
- 4) Press [EXECUTE] key, and the adjustment pattern is scanned.
- 5) Press [OK] key.

Item/Display		Content		Section
OC ADJ	MFT	Document lead edge	Image loss off-center sub scanning direction image magnification ratio adjustment (Document table mode)	Scanner
	CS1			
	CS2			
	ADU	Document off-center		
	CS3	Sub scanning magnification ratio		
	CS4			
LCC				

Item/Display		Content		Section		
SPF ADJ (RSPF)	ALL	SIDE1 (Front surface)	MFT	Document lead edge Image loss off-center sub scanning direction image magnification ratio adjustment (RSPF mode)	Scanner	
			CS1			Document off-center
		SIDE2 (Back surface)	ADU			Sub scanning magnification ratio
			CS3			
			CS4			
			LCC			Document lead edge Document off-center Sub scanning magnification ratio

Item/Display		Content		Section		
SETUP/PRINT ADJ	ALL	LEAD	MFT	Print lead edge adjustment, image off-center (each paper feed tray, duplex mode) adjustment	Engine	
			CS1			Print off center
			CS2			Print lead edge
		OFFSET	ADU			
			CS3			
			LCC			

Item/Display		Content		Section
BK-MAG ADJ	MFT	BK main scanning magnification ratio	Main scanning direction image magnification ratio adjustment	Engine
	CS1			
	CS2			
	ADU			
	CS3			
	CS4			
LCC				

RESULT	Adjustment result display
DATA	Adjustment operation data display

51

51-1

<b>Purpose</b>	Adjustment/Setup
<b>Function (Purpose)</b>	Used to adjust the ON/OFF timing of the secondary transport voltage.

**Section****Operation/Procedure**

- 1) Select an adjustment target item with scroll key on the touch panel.
- 2) Enter the set value with 10-key.
- 3) Press [OK] key. (The set value is saved.)

When the adjustment value is decreased, the transfer ON/OFF timing for the paper is advanced. When the adjustment value is increased, the timing is delayed.

When the adjustment value is changed by 1, the timing is changed by about 10ms. The setting range is -490 - +490ms.

Item/Display		Content	Default value
A	TC2 ON TIMING	Secondary transfer voltage ON timing setting	50
B	TC2 OFF TIMING	Secondary transfer voltage OFF timing setting	60

51-2

<b>Purpose</b>	Adjustment/Setup
<b>Function (Purpose)</b>	Used to adjust the contact pressure (deflection amount) on paper by the main unit and the RSPF registration roller. (This adjustment is performed when there is a considerable variation in the print image position on the paper or when paper jams frequently occur.)

**Section****Operation/Procedure**

- 1) (When RSPF model)  
Select a target adjustment mode with [SIDE1] or [SIDE2] or [ENGINE] keys.
- 2) Select a target item to be adjusted with scroll keys.
- 3) Enter the set value with 10-key.
- 4) Press [OK] key. (The set value is saved.)

[RSPF]

Mode	Display/Item	Content	Setting range	Default value					
				18cpm/ 20cpm machine	23cpm machine	26cpm/ 31cpm machine	36cpm machine		
SIDE1	A	NORMAL_PLAIN_HIGH	RSPF front surface document deflection amount adjustment value (Normal/Plain paper/HIGH)	-	1 - 99	50	50	50	50
	B	NORMAL_PLAIN_LOW	RSPF front surface document deflection amount adjustment value (Normal/Plain paper/LOW)	-	1 - 99	50	50	50	50
	C	NORMAL_THIN_HIGH	RSPF front surface document deflection amount adjustment value (Normal/Thin paper/HIGH)	-	1 - 99	50	50	50	50
	D	NORMAL_THIN_LOW	RSPF front surface document deflection amount adjustment value (Normal/Thin paper/LOW)	-	1 - 99	50	50	50	50
	E	RANDOM_PLAIN_HIGH	RSPF front surface document deflection amount adjustment value (Random/Plain paper/HIGH)	-	1 - 99	50	50	50	50
	F	RANDOM_PLAIN_LOW	RSPF front surface document deflection amount adjustment value (Random/Plain paper/LOW)	-	1 - 99	50	50	50	50
	G	RANDOM_THIN_HIGH	RSPF front surface document deflection amount adjustment value (Random/Thin paper/HIGH)	-	1 - 99	50	50	50	50
	H	RANDOM_THIN_LOW	RSPF front surface document deflection amount adjustment value (Random/Thin paper/LOW)	-	1 - 99	50	50	50	50
SIDE2	A	NORMAL_PLAIN_HIGH_1	RSPF back surface document deflection amount adjustment value 1 (Normal/Plain paper/HIGH)	-	1 - 99	50	50	50	50
	B	NORMAL_PLAIN_LOW_1	RSPF back surface document deflection amount adjustment value 1 (Normal/Plain paper/LOW)	-	1 - 99	50	50	50	50
ENGINE	A	TRAY1(S)	Main unit cassette 1 (Upper stage)/ deflection adjustment value (Plain paper/Small size)	LT size (216mm) or less	1 - 99	30	30	30	30
	B	TRAY1(L)	Main unit cassette 1 (Upper stage)/ deflection adjustment value (Plain paper/Large size)	LT size (216mm) or above	1 - 99	30	30	30	30
	C	TRAY1 HEAVY PAPER (S)	Main unit cassette 1 (Upper stage)/ deflection adjustment value (Heavy paper/Small size)	LT size (216mm) or less	1 - 99	40	10	10	2
	D	TRAY1 HEAVY PAPER (L)	Main unit cassette 1 (Upper stage)/ deflection adjustment value (Heavy paper/Large size)	LT size (216mm) or above	1 - 99	40	10	10	2
	E	TRAY2(S)	Main unit cassette 2 (Lower stage)/ deflection adjustment value (Plain paper/Small size)	LT size (216mm) or less	1 - 99	30	30	30	30
	F	TRAY2(L)	Main unit cassette 2 (Lower stage)/ deflection adjustment value (Plain paper/Large size)	LT size (216mm) or above	1 - 99	30	30	30	30
	G	TRAY2 HEAVY PAPER (S)	Main unit cassette 2 (Upper stage)/ deflection adjustment value (Heavy paper/Small size)	LT size (216mm) or less	1 - 99	40	10	10	2
	H	TRAY2 HEAVY PAPER (L)	Main unit cassette 2 (Upper stage)/ deflection adjustment value (Heavy paper/Large size)	LT size (216mm) or above	1 - 99	40	10	10	2
	I	MANUAL PLAIN PAPER (S)	Manual feed tray/deflection adjustment value (Plain paper/Small size)	LT size (216mm) or less	1 - 99	30	30	30	30
	J	MANUAL PLAIN PAPER (L)	Manual feed tray/deflection adjustment value (Plain paper/Large size)	LT size (216mm) or above	1 - 99	30	30	30	30
	K	MANUAL HEAVY PAPER (S)	Manual feed tray/deflection adjustment value (Heavy paper/Small size)	LT size (216mm) or less	1 - 99	40	10	10	2
	L	MANUAL HEAVY PAPER (L)	Manual feed tray/deflection adjustment value (Heavy paper/Large size)	LT size (216mm) or above	1 - 99	40	10	10	2
	M	MANUAL OHP	Manual feed tray/deflection adjustment value (OHP)	-	1 - 99	40	10	10	2
	N	MANUAL ENV	Manual feed tray/deflection adjustment value (Envelope)	-	1 - 99	40	10	10	2
O	ADU PLAIN PAPER (S)	ADU/deflection adjustment value (Plain paper/Small size)	LT size (216mm) or less	1 - 99	30	30	30	30	

Mode	Display/lte	Content	Setting range	Default value					
				18cpm/ 20cpm machine	23cpm machine	26cpm/ 31cpm machine	36cpm machine		
ENGINE	P	ADU PLAIN PAPER (L)	ADU/deflection adjustment value (Plain paper/Large size)	LT size (216mm) or above	1 - 99	30	30	30	30
	Q	ADU HEAVY PAPER (S)	ADU/deflection adjustment value (Heavy paper/Small size)	LT size (216mm) or less	1 - 99	40	10	10	2
	R	ADU HEAVY PAPER (L)	ADU/deflection adjustment value (Heavy paper/Large size)	LT size (216mm) or above	1 - 99	40	10	10	2
	S	DESK (S)	DESK/deflection adjustment value (Plain paper/Small size)	LT size (216mm) or less	1 - 99	30	30	30	30
	T	DESK (L)	DESK/deflection adjustment value (Plain paper/Large size)	LT size (216mm) or above	1 - 99	30	30	30	30
	U	DESK HEAVY PAPER (S)	DESK/deflection adjustment value (Heavy paper/Small size)	LT size (216mm) or less	1 - 99	40	10	10	2
	V	DESK HEAVY PAPER (L)	DESK/deflection adjustment value (Heavy paper/Large size)	LT size (216mm) or above	1 - 99	40	10	10	2
	W	A4LCC	A4LCC/deflection adjustment value	-	1 - 99	30	30	30	30

#### Note on "Large size" and "Small size"

Small size: The paper length in the transport direction is shorter than the LT size (216mm).

Large size: The paper length in the transport direction is longer than the LT size (216mm).

#### Adjustment value

When the adjustment value is increased, the warp amount is increased. When the adjustment value is decreased, the warp amount is decreased.

(When the adjustment value is changed by 1, the stop timing is changed by 0.1mm.)

**53**

<b>53-6</b>	
<b>Purpose</b>	Adjustment
<b>Function (Purpose)</b>	Used to adjust the detection level of the RSPF document width.
<b>Section</b>	

#### Operation/Procedure

- 1) Open the RSPF paper feed guide to the maximum width.
- 2) Press [EXECUTE] key.  
The maximum width detection level is recognized.
- 3) Open the RSPF paper feed guide to the A4R width.
- 4) Press [EXECUTE] key.  
The A4R width detection level is recognized.
- 5) Open the RSPF paper feed guide to the A5R width.
- 6) Press [EXECUTE] key.  
The A5R width detection level is recognized.
- 7) Open the RSPF paper feed guide to the minimum width.
- 8) Press [EXECUTE] key.  
The minimum width detection level is recognized.

When the above operation is not performed normally, "ERROR" is displayed and. When the above operation is completed normally, "COMPLETE" is displayed.

1	TRAYVOLMAX	Tray size volume maximum value
2	TRAYVOLA4R	Tray volume A4R size adjustment value
3	TRAYVOLA5R	Tray volume A5R size adjustment value
4	TRAYVOLMIN	Tray size volume minimum value

<b>53-7</b>	
<b>Purpose</b>	Adjustment/Setup
<b>Function (Purpose)</b>	Used to adjust the RSPF document size width sensor.
<b>Section</b>	

#### Operation/Procedure

- 1) Select an adjustment target item with scroll key on the touch panel.
- 2) Enter the set value with 10-key.
- 3) Press [OK] key. (The set value is saved.)

#### [RSPF]

	Item/Display	Setting range	Default value
A	AD_MAX	Max. width position	0 - 1023
B	AD_P1	A4R width position	509
C	AD_P2	A5R width position	808
D	AD_MIN	Min. width position	961

53-8

<b>Purpose</b>	Adjustment
<b>Function (Purpose)</b>	Used to adjust the document lead edge reference and the RSPF mode document scan position.

**Section****Operation/Procedure**

Select an adjustment item with [AUTO] [MANUAL] key.

<AUTO: Document lead edge reference (RRCA) adjustment>(Auto adjustment)

- 1) Set a sheet of black paper of A4 or 11"x 8.5" on the document table.
- 2) Press [EXECUTE] key. (The adjustment is performed and the adjustment value is saved.)

Item/Display	Content	Setting range	Default value
MEASUREMENT DISTANCE	Document lead edge measurement distance	0-255 (0.1mm unit)	-
RRCA	Document lead edge reference position	0 - 99	50

<MANUAL: RSPF mode document scan position adjustment>

- 1) Enter the set value with 10-key.
- 2) Press [OK] key. (The set value is saved.)

Item/Display	Content	Setting range	Default value
A ADJUST VALUE	RSPF mode document scan position adjustment (Scanner stop position adjustment)	1 - 99	5

- When the adjustment value is increased, the scanner stop position in the RSPF mode is shifted to the right.
- When the adjustment value is changed by 1, the position is shifted by 0.1mm.

**55**

55-1

<b>Purpose</b>	(Do not use this function unless specially required.)
----------------	---

<b>Function (Purpose)</b>	Used to set the specifications of the engine control operations. (SOFT SW)
---------------------------	--

**Section****Operation/Procedure**

55-2

<b>Purpose</b>	(Do not use this function unless specially required.)
----------------	---

<b>Function (Purpose)</b>	Used to set the specifications of the scanner control operation. (SOFT SW)
---------------------------	--

**Section****Operation/Procedure**

55-3

<b>Purpose</b>	(Do not use this function unless specially required.)
----------------	---

<b>Function (Purpose)</b>	Used to set the specifications of the controller operation. (SOFT SW)
---------------------------	---

**Section****Operation/Procedure**

55-10

<b>Purpose</b>	Adjustment/Setting
----------------	--------------------

<b>Function (Purpose)</b>	Used to set the special stamp text. (Taiwan only)
---------------------------	---

**Section****Operation/Procedure**

- 1) Select an item to be set (digit, color, type) with the scroll key.
- 2) Enter the value corresponding to the setting item with 10-key.
- 3) Press [OK] key.

	Item/Display	Content	Setting range	Default value	
A	1ST DIGIT	First digit (left edge)	1 - 90	1	
B	2ND DIGIT	Second digit			
C	3RD DIGIT	Third digit	32 [blank: 20H]		
D	4TH DIGIT	Fourth digit	65 - 90 [Alphabet: 41H("A") - 5AH("Z")]		
E	5TH DIGIT	Fifth digit	48 - 57 [Numeral: 30H("0") - 39H("9")]		
F	6TH DIGIT	Sixth digit (right edge)			
G	COLOR	K	Color specification input	0	
		C			
		M			
		Y			
		R			
		G			
		B			
H	TYPE	PATTERN 1	Print composing method	Edging type	1
		PATTERN 2		OR process type	
		PATTERN 3		No-delete-composition type	

**Input value**

Print	Blank	A	B	C	E	F	G
Input value	32	65	66	67	69	70	71

Print	H	I	J	K	L	M	N
Input value	72	73	74	75	76	77	78

Print	O	P	Q	R	T	U	V
Input value	79	80	81	82	84	85	86

Print	W	X	Y	Z	0	1	2
Input value	87	88	89	90	48	49	50

Print	3	5	6	7	8	9
Input value	51	53	54	55	56	57

# 56

## 56-1

<b>Purpose</b>	Backup
<b>Function (Purpose)</b>	Used to transport data between HDD - MFP PWB SRAM/EEPROM. (Used to repair the PWB.)

### Section

#### Operation/Procedure

- 1) Select a target content of data transfer.
- 2) Press [EXECUTE] key and press [YES] key.  
Data transfer of the item selected in procedure 1) is executed.  
When the operation is completed normally, "COMPLETE" is displayed. In case of an abnormal end, "ERROR" is displayed.

EEPROM → HDD	Transfer from EEPROM to HDD
HDD → EEPROM	Transfer from HDD to EEPROM

## 56-2

<b>Purpose</b>	Data backup
<b>Function (Purpose)</b>	Used to backup the data in the EEPROM, SD Card, and HDD (including user authentication data and address data) to the USB memory. (Corresponding to the device cloning and the storage backup.)

### Section

#### Operation/Procedure

- 1) Insert the USB memory into the main unit.
- 2) Select a target transfer item with the touch panel.  
<IMPORT>  
From USB MEMORY DEVICE To EEPROM, SD Card HDD  
<EXPORT>  
From EEPROM, SD Card, HDD To USB MEMORY
- 3) Press [EXECUTE] key, and press [YES] key.  
Data transfer selected in the procedure 2) is performed  
When the operation is completed normally, "COMPLETE" is displayed. In case of an abnormal end, "ERROR" is displayed.

(Machine with the DSK installed)

- 1) Insert the USB memory into the main unit.
- 2) Select a target transfer item with the touch panel.  
<IMPORT>  
From USB MEMORY DEVICE to EEPROM, SD Card HDD  
<EXPORT>  
From EEPROM, SD Card, HDD to USB MEMORY DEVICE
- 3) Enter the password with 10-key.
- 4) Press [SET] key.
- 5) Press [EXECUTE] key, and press [YES] key.  
Data transfer selected in the procedure 2) is performed.  
When the operation is completed normally, "COMPLETE" is displayed. In case of an abnormal end, "ERROR" is displayed.

<Data list outside the backup targets>

(EEPROM/SD Card)

PWB Type	Content	NOTE
Controller	Machine serial No.	
	Product key information	
	Various counter	Copy counter/FAX send counter etc.
	Trouble history	

PWB Type	Content	NOTE
PCU	Machine serial No.	
	Various counter	Maintenance counter
	Machine adjustment execute history	
	Trouble history	
SCU	Various counter	Maintenance counter
	Trouble history	

(HDD)

Classification	Content	NOTE
Japanese FEP	User dictionary	
Job end list	Job end list display data (The image send series include the preserved job list.)	
Log	Job log	Read from WEB is enable.
New N/A	<ul style="list-style-type: none"> <li>• Print history information</li> <li>• JAM history information</li> <li>• Trouble history information</li> <li>• Same position continuous jam count value</li> <li>• Charging information</li> <li>• Life information</li> </ul>	
Operation manual	E-manual	

## 56-3

<b>Purpose</b>	Data backup
<b>Function (Purpose)</b>	Used to backup the document filing data to the USB memory.

### Section

#### Operation/Procedure

- 1) Insert the USB memory into the main unit.
- 2) Select a target transfer item with the touch panel.  
<IMPORT>  
From USB MEMORY DEVICE to EEPROM, SD Card, HDD  
<EXPORT>  
From EEPROM, SD Card, HDD to USB MEMORY DEVICE
- 3) Press [EXECUTE] key, and press [YES] key.  
Data transfer selected in the procedure 2) is performed.  
When the operation is completed normally, "COMPLETE" is displayed. In case of an abnormal end, "ERROR" is displayed.

## 56-4

<b>Purpose</b>	Data backup
<b>Function (Purpose)</b>	Used to backup the JOB log data to the USB memory.

### Section

#### Operation/Procedure

- 1) Insert the USB memory into the main unit.
- 2) Press [JOB LOG EXPORT] key.
- 3) Press [EXECUTE] key, and press [YES] key.  
Data transfer selected in the procedure 2) is performed.  
When the operation is completed normally, "COMPLETE" is displayed. In case of an abnormal end, "ERROR" is displayed.

<b>56-5</b>	
<b>Purpose</b>	Adjustment/Setting/Operation data check
<b>Function (Purpose)</b>	Used to import the SIM22-6 data to a USB memory in the TEXT format.

**Section**

**Operation/Procedure**

- 1) Insert the USB memory into the main unit.
- 2) Select a kind of data to be imported.
- 3) Press [EXECUTE] key, and press [YES] key.

Procedure 2) The selected data are imported.

When the operation is completed normally, "COMPLETE" is displayed. In case of an abnormal end, "ERROR" is displayed.

<b>56-11</b>	
<b>Purpose</b>	Data copy
<b>Function (Purpose)</b>	Used to copy the SD Card data to an option HDD.

**Section**

**Operation/Procedure**

- 1) Install an option HDD.
- 2) Press [EXECUTE] key, and press [YES] key.

The SD Card data are copied to the option HDD.

When the operation is completed normally, "COMPLETE" is displayed. In case of an abnormal end, "ERROR" is displayed.

**Note**

This simulation functions only for the 18cpm/20cpm model without HDD.

Result display	Description
COMPLETE	Normal completion
ERROR (HDD ACCESS ERROR)	HDD access disable
ERROR (LOW LEVEL BLOCK WRITE ERROR)	Write error
ERROR (LOW LEVEL BLOCK READ ERROR)	Read error
ERROR (NO DATA ADJUSTMENT)	Data discrepancy between the SD Card and the HDD
TROUBLE (U2-42)	U2-42 occurrence

<b>56-12</b>	
<b>Purpose</b>	Data copy
<b>Function (Purpose)</b>	Used to copy the SD Card data to an option HDD.
<b>Section</b>	MFP PWB/HDD

**Operation/Procedure**

- 1) Install the accessory SD Card (4GB) to the option HDD kit.
- 2) Press [EXECUTE] key, and press [YES] key.

The data which were copied to the HDD with SIM56-11 are copied to the SD Card (4GB).

When the operation is completed normally, "COMPLETE" is displayed. In case of an abnormal end, "ERROR" is displayed.

**Note**

This simulation functions only for the 18cpm/20cpm model with HDD installed.

Result display	Description
COMPLETE	Normal completion
NO DATA	There are no copy data of the SD Card in the HDD.
ERROR (EXPORT DATA ILLEGAL)	SD Card data error in the HDD
ERROR (LOW LEVEL BLOCK READ ERROR)	Read error
ERROR (NO DATA ADJUSTMENT)	Data discrepancy between the SD Card and the HDD
ERROR (SD ACCESS ERROR)	SD Card access error

**60**

<b>60-1</b>	
<b>Purpose</b>	Operation test/check
<b>Function (Purpose)</b>	Used to check the memory operations (read/write) of the MFP PWB.

**Section**

**Operation/Procedure**

- 1) Press [EXECUTE] key.  
Start the test.

Result display	Description
OK	Success
NG	Fail
NONE	Not installed (Including DIMM trouble)
INVALID	Execution disable

SLOT	Description	
ICU SLOT-1	ICU standard memory	DIMM1
ICU SLOT-2	ICU expansion memory	DIMM2
PCL SLOT-1	Printer standard memory	DIMM3
PCL SLOT-2	Printer expansion memory	DIMM4
ACRE SLOT	Enhanced compression kit memory	-

**61**

<b>61-1</b>	
<b>Purpose</b>	Operation test/check
<b>Function (Purpose)</b>	Used to check the LSU polygon motor rotation and laser detection.
<b>Section</b>	LSU

**Operation/Procedure**

- 1) Press [EXECUTE] key.

When the operation is completed normally, [OK] is displayed. In case of an abnormal end, [NG] is displayed.

Display	Content
LSU TESTRESULT NG: PG	Polygon mirror rotation abnormality
LSU TESTRESULT NG: K	Laser abnormality (K)
LSU TESTRESULT NG: CL	Laser light emitting abnormality (C,M,Y)

<b>Purpose</b>	Adjustment/Setup
<b>Function (Purpose)</b>	Used to set the laser power
<b>Section</b>	

**Operation/Procedure**

- 1) Select a target mode for adjustment with [COPY], [PR600/ FAX] on the touch panel.
- 2) Select an adjustment target item with scroll key on the touch panel.
- 3) Enter the adjustment value using the 10-key.
- 4) Press [OK] key. (The set value is saved.)

When the laser power and the DUTY adjustment value are increased, the print density is increased and the line width of line images are increased.

**18cpm/20cpm machine**

Mode	Item/Display	Content	Setting range	Default value	Destination linkage	
COPY	A	LASER POWER MIDDLE (K1)	Used to set the laser power (Middle speed/K1)	0 - 255	110	×
	B	LASER POWER MIDDLE (K2)	Used to set the laser power (Middle speed/K2)	0 - 255	110	×
	C	LASER POWER MIDDLE (C1)	Used to set the laser power (Middle speed/C1)	0 - 255	110	×
	D	LASER POWER MIDDLE (C2)	Used to set the laser power (Middle speed/C2)	0 - 255	110	×
	E	LASER POWER MIDDLE (M1)	Used to set the laser power (Middle speed/M1)	0 - 255	110	×
	F	LASER POWER MIDDLE (M2)	Used to set the laser power (Middle speed/M2)	0 - 255	110	×
	G	LASER POWER MIDDLE (Y1)	Used to set the laser power (Middle speed/Y1)	0 - 255	110	×
	H	LASER POWER MIDDLE (Y2)	Used to set the laser power (Middle speed/Y2)	0 - 255	110	×
	I	LASER POWER LOW (K1)	Used to set the laser power (Low speed/K1)	0 - 255	141	×
	J	LASER POWER LOW (K2)	Used to set the laser power (Low speed/K2)	0 - 255	141	×
	K	LASER POWER LOW (C1)	Used to set the laser power (Low speed/C1)	0 - 255	141	×
	L	LASER POWER LOW (C2)	Used to set the laser power (Low speed/C2)	0 - 255	141	×
	M	LASER POWER LOW (M1)	Used to set the laser power (Low speed/M1)	0 - 255	141	×
	N	LASER POWER LOW (M2)	Used to set the laser power (Low speed/M2)	0 - 255	141	×
	O	LASER POWER LOW (Y1)	Used to set the laser power (Low speed/Y1)	0 - 255	141	×
	P	LASER POWER LOW (Y2)	Used to set the laser power (Low speed/Y2)	0 - 255	141	×
	Q	LASER POWER MIDDLE (BW1)	Used to set the laser power (Middle speed/BW1)	0 - 255	110	×
	R	LASER POWER MIDDLE (BW2)	Used to set the laser power (Middle speed/BW2)	0 - 255	110	×
	S	LASER POWER LOW (BW1)	Used to set the laser power (Low speed/BW1)	0 - 255	141	×
	T	LASER POWER LOW (BW2)	Used to set the laser power (Low speed/BW2)	0 - 255	141	×
	U	LASER DUTY MIDDLE (K)	Laser DUTY select middle speed (K)	0 - 255	0	○
	V	LASER DUTY MIDDLE (C)	Laser DUTY select middle speed (C)	0 - 255	0	○
	W	LASER DUTY MIDDLE (M)	Laser DUTY select middle speed (M)	0 - 255	0	○
	X	LASER DUTY MIDDLE (Y)	Laser DUTY select middle speed (Y)	0 - 255	0	○
	Y	LASER DUTY LOW (K)	Laser DUTY select low speed (K)	0 - 255	0	○
	Z	LASER DUTY LOW (C)	Laser DUTY select low speed (C)	0 - 255	0	○
	AA	LASER DUTY LOW (M)	Laser DUTY select low speed (M)	0 - 255	0	○
	AB	LASER DUTY LOW (Y)	Laser DUTY select low speed (Y)	0 - 255	0	○
	AC	LASER DUTY MIDDLE(BW)	Laser DUTY select middle speed (BW)	0 - 255	0	○
	AD	LASER DUTY LOW (BW)	Laser DUTY select low speed (BW)	0 - 255	0	○
	AE	LASER DUTY MIDDLE (K 1BIT)	Laser DUTY select middle speed (K)*1	0 - 255	0	○
	AF	LASER DUTY MIDDLE (C 1BIT)	Laser DUTY select middle speed (C)*1	0 - 255	0	○
AG	LASER DUTY MIDDLE (M 1BIT)	Laser DUTY select middle speed (M)*1	0 - 255	0	○	
AH	LASER DUTY MIDDLE (Y 1BIT)	Laser DUTY select middle speed (Y)*1	0 - 255	0	○	
AI	LASER DUTY LOW (K 1BIT)	Laser DUTY select low speed (K)*1	0 - 255	0	○	
AJ	LASER DUTY LOW (C 1BIT)	Laser DUTY select low speed (C)*1	0 - 255	0	○	
AK	LASER DUTY LOW (M 1BIT)	Laser DUTY select low speed (M)*1	0 - 255	0	○	
AL	LASER DUTY LOW (Y 1BIT)	Laser DUTY select low speed (Y)*1	0 - 255	0	○	
AM	LASER DUTY MIDDLE (BW 1BIT)	Laser DUTY select middle speed (BW)*1	0 - 255	0	○	
AN	LASER DUTY LOW (BW 1BIT)	Laser DUTY select low speed (BW)	0 - 255	0	○	
PR600/FAX	A	LASER POWER MIDDLE (K1)	Used to set the laser power (Middle speed/K1)	0 - 255	110	×
	B	LASER POWER MIDDLE (K2)	Used to set the laser power (Middle speed/K2)	0 - 255	110	×
	C	LASER POWER MIDDLE (C1)	Used to set the laser power (Middle speed/C1)	0 - 255	110	×
	D	LASER POWER MIDDLE (C2)	Used to set the laser power (Middle speed/C2)	0 - 255	110	×
	E	LASER POWER MIDDLE (M1)	Used to set the laser power (Middle speed/M1)	0 - 255	110	×
	F	LASER POWER MIDDLE (M2)	Used to set the laser power (Middle speed/M2)	0 - 255	110	×
	G	LASER POWER MIDDLE (Y1)	Used to set the laser power (Middle speed/Y1)	0 - 255	110	×
	H	LASER POWER MIDDLE (Y2)	Used to set the laser power (Middle speed/Y2)	0 - 255	110	×
	I	LASER POWER LOW (K1)	Used to set the laser power (Low speed/K1)	0 - 255	141	×
	J	LASER POWER LOW (K2)	Used to set the laser power (Low speed/K2)	0 - 255	141	×
	K	LASER POWER LOW (C1)	Used to set the laser power (Low speed/C1)	0 - 255	141	×

Mode	Item/Display	Content	Setting range	Default value		Destination linkage
PR600/FAX	L	LASER POWER LOW (C2)	Used to set the laser power (Low speed/C2)	0 - 255	141	X
	M	LASER POWER LOW (M1)	Used to set the laser power (Low speed/M1)	0 - 255	141	X
	N	LASER POWER LOW (M2)	Used to set the laser power (Low speed/M2)	0 - 255	141	X
	O	LASER POWER LOW (Y1)	Used to set the laser power (Low speed/Y1)	0 - 255	141	X
	P	LASER POWER LOW (Y2)	Used to set the laser power (Low speed/Y2)	0 - 255	141	X
	Q	LASER POWER MIDDLE (BW1)	Used to set the laser power (Middle speed/BW1)	0 - 255	110	X
	R	LASER POWER MIDDLE (BW2)	Used to set the laser power (Middle speed/BW2)	0 - 255	110	X
	S	LASER POWER LOW (BW1)	Used to set the laser power (Low speed/BW1)	0 - 255	141	X
	T	LASER POWER LOW (BW2)	Used to set the laser power (Low speed/BW2)	0 - 255	141	X
	U	LASER DUTY MIDDLE (K)	Laser DUTY select middle speed (K)	0 - 255	0	○
	V	LASER DUTY MIDDLE (C)	Laser DUTY select middle speed (C)	0 - 255	0	○
	W	LASER DUTY MIDDLE (M)	Laser DUTY select middle speed (M)	0 - 255	0	○
	X	LASER DUTY MIDDLE (Y)	Laser DUTY select middle speed (Y)	0 - 255	0	○
	Y	LASER DUTY LOW (K)	Laser DUTY select low speed (K)	0 - 255	0	○
	Z	LASER DUTY LOW (C)	Laser DUTY select low speed (C)	0 - 255	0	○
	AA	LASER DUTY LOW (M)	Laser DUTY select low speed (M)	0 - 255	0	○
	AB	LASER DUTY LOW (Y)	Laser DUTY select low speed (Y)	0 - 255	0	○
	AC	LASER DUTY MIDDLE (BW)	Laser DUTY select middle speed (BW)	0 - 255	0	○
	AD	LASER DUTY LOW (BW)	Laser DUTY select low speed (BW)	0 - 255	0	○
	AE	LASER DUTY MIDDLE (K 1BIT)	Laser DUTY select middle speed (K)	0 - 255	0	○
	AF	LASER DUTY MIDDLE (C 1BIT)	Laser DUTY select middle speed (C)	0 - 255	0	○
	AG	LASER DUTY MIDDLE (M 1BIT)	Laser DUTY select middle speed (M)	0 - 255	0	○
	AH	LASER DUTY MIDDLE (Y 1BIT)	Laser DUTY select middle speed (Y)	0 - 255	0	○
	AI	LASER DUTY LOW (K 1BIT)	Laser DUTY select low speed (K)	0 - 255	0	○
	AJ	LASER DUTY LOW (C 1BIT)	Laser DUTY select low speed (C)	0 - 255	0	○
	AK	LASER DUTY LOW (M 1BIT)	Laser DUTY select low speed (M)	0 - 255	0	○
	AL	LASER DUTY LOW (Y 1BIT)	Laser DUTY select low speed (Y)	0 - 255	0	○
	AM	LASER DUTY MIDDLE (BW 1BIT)	Laser DUTY select middle speed (BW)	0 - 255	0	○
AN	LASER DUTY LOW (BW 1BIT)	Laser DUTY select low speed (BW)	0 - 255	0	○	

### 23cpm/31cpm(G) machine

Mode	Item/Display	Content	Setting range	Default value		Destination linkage	
				23cpm machine	31cpm(G) machine		
COPY	A	LASER POWER MIDDLE (K1)	Used to set the laser power (Middle speed/K1)	0 - 255	110	148	X
	B	LASER POWER MIDDLE (K2)	Used to set the laser power (Middle speed/K2)	0 - 255	110	148	X
	C	LASER POWER MIDDLE (C1)	Used to set the laser power (Middle speed/C1)	0 - 255	110	148	X
	D	LASER POWER MIDDLE (C2)	Used to set the laser power (Middle speed/C2)	0 - 255	110	148	X
	E	LASER POWER MIDDLE (M1)	Used to set the laser power (Middle speed/M1)	0 - 255	110	148	X
	F	LASER POWER MIDDLE (M2)	Used to set the laser power (Middle speed/M2)	0 - 255	110	148	X
	G	LASER POWER MIDDLE (Y1)	Used to set the laser power (Middle speed/Y1)	0 - 255	110	148	X
	H	LASER POWER MIDDLE (Y2)	Used to set the laser power (Middle speed/Y2)	0 - 255	110	148	X
	I	LASER POWER LOW (K1)	Used to set the laser power (Low speed/K1)	0 - 255	141	141	X
	J	LASER POWER LOW (K2)	Used to set the laser power (Low speed/K2)	0 - 255	141	141	X
	K	LASER POWER LOW (C1)	Used to set the laser power (Low speed/C1)	0 - 255	141	141	X
	L	LASER POWER LOW (C2)	Used to set the laser power (Low speed/C2)	0 - 255	141	141	X
	M	LASER POWER LOW (M1)	Used to set the laser power (Low speed/M1)	0 - 255	141	141	X
	N	LASER POWER LOW (M2)	Used to set the laser power (Low speed/M2)	0 - 255	141	141	X
	O	LASER POWER LOW (Y1)	Used to set the laser power (Low speed/Y1)	0 - 255	141	141	X
	P	LASER POWER LOW (Y2)	Used to set the laser power (Low speed/Y2)	0 - 255	141	141	X
	Q	LASER POWER MIDDLE (BW1)	Used to set the laser power (Middle speed/BW1)	0 - 255	110	148	X
	R	LASER POWER MIDDLE (BW2)	Used to set the laser power (Middle speed/BW2)	0 - 255	110	148	X
	S	LASER POWER LOW (BW1)	Used to set the laser power (Low speed/BW1)	0 - 255	141	141	X
	T	LASER POWER LOW (BW2)	Used to set the laser power (Low speed/BW2)	0 - 255	141	141	X
	U	LASER DUTY MIDDLE (K)	Laser DUTY select middle speed (K)	0 - 255	0	0	○
	V	LASER DUTY MIDDLE (C)	Laser DUTY select middle speed (C)	0 - 255	0	0	○
	W	LASER DUTY MIDDLE (M)	Laser DUTY select middle speed (M)	0 - 255	0	0	○
	X	LASER DUTY MIDDLE (Y)	Laser DUTY select middle speed (Y)	0 - 255	0	0	○
	Y	LASER DUTY LOW (K)	Laser DUTY select low speed (K)	0 - 255	0	0	○
	Z	LASER DUTY LOW (C)	Laser DUTY select low speed (C)	0 - 255	0	0	○
	AA	LASER DUTY LOW (M)	Laser DUTY select low speed (M)	0 - 255	0	0	○
	AB	LASER DUTY LOW (Y)	Laser DUTY select low speed (Y)	0 - 255	0	0	○
AC	LASER DUTY MIDDLE (BW)	Laser DUTY select middle speed (BW)	0 - 255	0	0	○	
AD	LASER DUTY LOW (BW)	Laser DUTY select low speed (BW)	0 - 255	0	0	○	



Mode	Item/Display		Content	Setting range	Default value		Destination linkage
					23cpm machine	31cpm(G) machine	
PR600/FAX	A	LASER POWER MIDDLE (K1)	Used to set the laser power (Middle speed/K1)	0 - 255	110	148	X
	B	LASER POWER MIDDLE (K2)	Used to set the laser power (Middle speed/K2)	0 - 255	110	148	X
	C	LASER POWER MIDDLE (C1)	Used to set the laser power (Middle speed/C1)	0 - 255	110	148	X
	D	LASER POWER MIDDLE (C2)	Used to set the laser power (Middle speed/C2)	0 - 255	110	148	X
	E	LASER POWER MIDDLE (M1)	Used to set the laser power (Middle speed/M1)	0 - 255	110	148	X
	F	LASER POWER MIDDLE (M2)	Used to set the laser power (Middle speed/M2)	0 - 255	110	148	X
	G	LASER POWER MIDDLE (Y1)	Used to set the laser power (Middle speed/Y1)	0 - 255	110	148	X
	H	LASER POWER MIDDLE (Y2)	Used to set the laser power (Middle speed/Y2)	0 - 255	110	148	X
	I	LASER POWER LOW (K1)	Used to set the laser power (Low speed/K1)	0 - 255	141	141	X
	J	LASER POWER LOW (K2)	Used to set the laser power (Low speed/K2)	0 - 255	141	141	X
	K	LASER POWER LOW (C1)	Used to set the laser power (Low speed/C1)	0 - 255	141	141	X
	L	LASER POWER LOW (C2)	Used to set the laser power (Low speed/C2)	0 - 255	141	141	X
	M	LASER POWER LOW (M1)	Used to set the laser power (Low speed/M1)	0 - 255	141	141	X
	N	LASER POWER LOW (M2)	Used to set the laser power (Low speed/M2)	0 - 255	141	141	X
	O	LASER POWER LOW (Y1)	Used to set the laser power (Low speed/Y1)	0 - 255	141	141	X
	P	LASER POWER LOW (Y2)	Used to set the laser power (Low speed/Y2)	0 - 255	141	141	X
	Q	LASER POWER MIDDLE (BW1)	Used to set the laser power (Middle speed/BW1)	0 - 255	110	148	X
	R	LASER POWER MIDDLE (BW2)	Used to set the laser power (Middle speed/BW2)	0 - 255	110	148	X
	S	LASER POWER LOW (BW1)	Used to set the laser power (Low speed/BW1)	0 - 255	141	141	X
	T	LASER POWER LOW (BW2)	Used to set the laser power (Low speed/BW2)	0 - 255	141	141	X
	U	LASER DUTY MIDDLE (K)	Laser DUTY select middle speed (K)	0 - 255	0	0	O
	V	LASER DUTY MIDDLE (C)	Laser DUTY select middle speed (C)	0 - 255	0	0	O
	W	LASER DUTY MIDDLE (M)	Laser DUTY select middle speed (M)	0 - 255	0	0	O
	X	LASER DUTY MIDDLE (Y)	Laser DUTY select middle speed (Y)	0 - 255	0	0	O
	Y	LASER DUTY LOW (K)	Laser DUTY select low speed (K)	0 - 255	0	0	O
	Z	LASER DUTY LOW (C)	Laser DUTY select low speed (C)	0 - 255	0	0	O
	AA	LASER DUTY LOW (M)	Laser DUTY select low speed (M)	0 - 255	0	0	O
	AB	LASER DUTY LOW (Y)	Laser DUTY select low speed (Y)	0 - 255	0	0	O
	AC	LASER DUTY MIDDLE (BW)	Laser DUTY select middle speed (BW)	0 - 255	0	0	O
	AD	LASER DUTY LOW (BW)	Laser DUTY select low speed (BW)	0 - 255	0	0	O
	AE	LASER DUTY MIDDLE (K 1BIT)	Laser DUTY select middle speed (K)	0 - 255	0	0	O
	AF	LASER DUTY MIDDLE (C 1BIT)	Laser DUTY select middle speed (C)	0 - 255	0	0	O
	AG	LASER DUTY MIDDLE (M 1BIT)	Laser DUTY select middle speed (M)	0 - 255	0	0	O
	AH	LASER DUTY MIDDLE (Y 1BIT)	Laser DUTY select middle speed (Y)	0 - 255	0	0	O
AI	LASER DUTY LOW (K 1BIT)	Laser DUTY select low speed (K)	0 - 255	0	0	O	
AJ	LASER DUTY LOW (C 1BIT)	Laser DUTY select low speed (C)	0 - 255	0	0	O	
AK	LASER DUTY LOW (M 1BIT)	Laser DUTY select low speed (M)	0 - 255	0	0	O	
AL	LASER DUTY LOW (Y 1BIT)	Laser DUTY select low speed (Y)	0 - 255	0	0	O	
AM	LASER DUTY MIDDLE (BW 1BIT)	Laser DUTY select middle speed (BW)	0 - 255	0	0	O	
AN	LASER DUTY LOW (BW 1BIT)	Laser DUTY select low speed (BW)	0 - 255	0	0	O	

**26cpm/36cpm/31cpm(A) machine**

Mode	Item/Display		Content	Setting range	Default value		Destination linkage
					26cpm/31cpm(A) machine	36cpm machine	
COPY	A	LASER POWER MIDDLE (K1)	Used to set the laser power (Middle speed/K1)	0 - 255	128	151	X
	B	LASER POWER MIDDLE (K2)	Used to set the laser power (Middle speed/K2)	0 - 255	128	151	X
	C	LASER POWER MIDDLE (C1)	Used to set the laser power (Middle speed/C1)	0 - 255	128	151	X
	D	LASER POWER MIDDLE (C2)	Used to set the laser power (Middle speed/C2)	0 - 255	128	151	X
	E	LASER POWER MIDDLE (M1)	Used to set the laser power (Middle speed/M1)	0 - 255	128	151	X
	F	LASER POWER MIDDLE (M2)	Used to set the laser power (Middle speed/M2)	0 - 255	128	151	X
	G	LASER POWER MIDDLE (Y1)	Used to set the laser power (Middle speed/Y1)	0 - 255	128	151	X
	H	LASER POWER MIDDLE (Y2)	Used to set the laser power (Middle speed/Y2)	0 - 255	128	151	X
	I	LASER POWER LOW (K1)	Used to set the laser power (Low speed/K1)	0 - 255	128	151	X
	J	LASER POWER LOW (K2)	Used to set the laser power (Low speed/K2)	0 - 255	128	151	X
	K	LASER POWER LOW (C1)	Used to set the laser power (Low speed/C1)	0 - 255	128	151	X
	L	LASER POWER LOW (C2)	Used to set the laser power (Low speed/C2)	0 - 255	128	151	X
	M	LASER POWER LOW (M1)	Used to set the laser power (Low speed/M1)	0 - 255	128	151	X
	N	LASER POWER LOW (M2)	Used to set the laser power (Low speed/M2)	0 - 255	128	151	X
	O	LASER POWER LOW (Y1)	Used to set the laser power (Low speed/Y1)	0 - 255	128	151	X
	P	LASER POWER LOW (Y2)	Used to set the laser power (Low speed/Y2)	0 - 255	128	151	X
	Q	LASER POWER MIDDLE (BW1)	Used to set the laser power (Middle speed/BW1)	0 - 255	128	151	X
	R	LASER POWER MIDDLE (BW2)	Used to set the laser power (Middle speed/BW2)	0 - 255	128	151	X
	S	LASER POWER LOW (BW1)	Used to set the laser power (Low speed/BW1)	0 - 255	128	151	X
	T	LASER POWER LOW (BW2)	Used to set the laser power (Low speed/BW2)	0 - 255	128	151	X
	U	LASER DUTY MIDDLE (K)	Laser DUTY select middle speed (K)	0 - 255	0	0	O
	V	LASER DUTY MIDDLE (C)	Laser DUTY select middle speed (C)	0 - 255	0	0	O
	W	LASER DUTY MIDDLE (M)	Laser DUTY select middle speed (M)	0 - 255	0	0	O

Mode	Item/Display		Content	Setting range	Default value		Destination linkage
					26cpm/31cpm(A) machine	36cpm machine	
COPY	X	LASER DUTY MIDDLE (Y)	Laser DUTY select middle speed (Y)	0 - 255	0	0	○
	Y	LASER DUTY LOW (K)	Laser DUTY select low speed (K)	0 - 255	0	0	○
	Z	LASER DUTY LOW (C)	Laser DUTY select low speed (C)	0 - 255	0	0	○
	AA	LASER DUTY LOW (M)	Laser DUTY select low speed (M)	0 - 255	0	0	○
	AB	LASER DUTY LOW (Y)	Laser DUTY select low speed (Y)	0 - 255	0	0	○
	AC	LASER DUTY MIDDLE(BW)	Laser DUTY select middle speed (BW)	0 - 255	0	0	○
AD	LASER DUTY LOW (BW)	Laser DUTY select low speed (BW)	0 - 255	0	0	○	
PR600/FAX	A	LASER POWER MIDDLE (K1)	Used to set the laser power (Middle speed/K1)	0 - 255	128	151	×
	B	LASER POWER MIDDLE (K2)	Used to set the laser power (Middle speed/K2)	0 - 255	128	151	×
	C	LASER POWER MIDDLE (C1)	Used to set the laser power (Middle speed/C1)	0 - 255	128	151	×
	D	LASER POWER MIDDLE (C2)	Used to set the laser power (Middle speed/C2)	0 - 255	128	151	×
	E	LASER POWER MIDDLE (M1)	Used to set the laser power (Middle speed/M1)	0 - 255	128	151	×
	F	LASER POWER MIDDLE (M2)	Used to set the laser power (Middle speed/M2)	0 - 255	128	151	×
	G	LASER POWER MIDDLE (Y1)	Used to set the laser power (Middle speed/Y1)	0 - 255	128	151	×
	H	LASER POWER MIDDLE (Y2)	Used to set the laser power (Middle speed/Y2)	0 - 255	128	151	×
	I	LASER POWER LOW (K1)	Used to set the laser power (Low speed/K1)	0 - 255	128	151	×
	J	LASER POWER LOW (K2)	Used to set the laser power (Low speed/K2)	0 - 255	128	151	×
	K	LASER POWER LOW (C1)	Used to set the laser power (Low speed/C1)	0 - 255	128	151	×
	L	LASER POWER LOW (C2)	Used to set the laser power (Low speed/C2)	0 - 255	128	151	×
	M	LASER POWER LOW (M1)	Used to set the laser power (Low speed/M1)	0 - 255	128	151	×
	N	LASER POWER LOW (M2)	Used to set the laser power (Low speed/M2)	0 - 255	128	151	×
	O	LASER POWER LOW (Y1)	Used to set the laser power (Low speed/Y1)	0 - 255	128	151	×
	P	LASER POWER LOW (Y2)	Used to set the laser power (Low speed/Y2)	0 - 255	128	151	×
	Q	LASER POWER MIDDLE (BW1)	Used to set the laser power (Middle speed/BW1)	0 - 255	128	151	×
	R	LASER POWER MIDDLE (BW2)	Used to set the laser power (Middle speed/BW2)	0 - 255	128	151	×
	S	LASER POWER LOW (BW1)	Used to set the laser power (Low speed/BW1)	0 - 255	128	151	×
	T	LASER POWER LOW (BW2)	Used to set the laser power (Low speed/BW2)	0 - 255	128	151	×
	U	LASER DUTY MIDDLE (K)	Laser DUTY select middle speed (K)	0 - 255	0	0	○
	V	LASER DUTY MIDDLE (C)	Laser DUTY select middle speed (C)	0 - 255	0	0	○
	W	LASER DUTY MIDDLE (M)	Laser DUTY select middle speed (M)	0 - 255	0	0	○
	X	LASER DUTY MIDDLE (Y)	Laser DUTY select middle speed (Y)	0 - 255	0	0	○
	Y	LASER DUTY LOW (K)	Laser DUTY select low speed (K)	0 - 255	0	0	○
	Z	LASER DUTY LOW (C)	Laser DUTY select low speed (C)	0 - 255	0	0	○
	AA	LASER DUTY LOW (M)	Laser DUTY select low speed (M)	0 - 255	0	0	○
	AB	LASER DUTY LOW (Y)	Laser DUTY select low speed (Y)	0 - 255	0	0	○
	AC	LASER DUTY MIDDLE (BW)	Laser DUTY select middle speed (BW)	0 - 255	0	0	○
	AD	LASER DUTY LOW (BW)	Laser DUTY select low speed (BW)	0 - 255	0	0	○
AE	LASER DUTY MIDDLE (K 1BIT)	Laser DUTY select middle speed (K)	0 - 255	0	0	○	
AF	LASER DUTY MIDDLE (C 1BIT)	Laser DUTY select middle speed (C)	0 - 255	0	0	○	
AG	LASER DUTY MIDDLE (M 1BIT)	Laser DUTY select middle speed (M)	0 - 255	0	0	○	
AH	LASER DUTY MIDDLE (Y 1BIT)	Laser DUTY select middle speed (Y)	0 - 255	0	0	○	
AI	LASER DUTY LOW (K 1BIT)	Laser DUTY select low speed (K)	0 - 255	0	0	○	
AJ	LASER DUTY LOW (C 1BIT)	Laser DUTY select low speed (C)	0 - 255	0	0	○	
AK	LASER DUTY LOW (M 1BIT)	Laser DUTY select low speed (M)	0 - 255	0	0	○	
AL	LASER DUTY LOW (Y 1BIT)	Laser DUTY select low speed (Y)	0 - 255	0	0	○	
AM	LASER DUTY MIDDLE (BW 1BIT)	Laser DUTY select middle speed (BW)	0 - 255	0	0	○	
AN	LASER DUTY LOW (BW 1BIT)	Laser DUTY select low speed (BW)	0 - 255	0	0	○	
PR1200	A	LASER POWER MIDDLE (K1)	Used to set the laser power (Middle speed/K1)	0 - 255	128	151	×
	B	LASER POWER MIDDLE (K2)	Used to set the laser power (Middle speed/K2)	0 - 255	128	151	×
	C	LASER POWER MIDDLE (C1)	Used to set the laser power (Middle speed/C1)	0 - 255	128	151	×
	D	LASER POWER MIDDLE (C2)	Used to set the laser power (Middle speed/C2)	0 - 255	128	151	×
	E	LASER POWER MIDDLE (M1)	Used to set the laser power (Middle speed/M1)	0 - 255	128	151	×
	F	LASER POWER MIDDLE (M2)	Used to set the laser power (Middle speed/M2)	0 - 255	128	151	×
	G	LASER POWER MIDDLE (Y1)	Used to set the laser power (Middle speed/Y1)	0 - 255	128	151	×
	H	LASER POWER MIDDLE (Y2)	Used to set the laser power (Middle speed/Y2)	0 - 255	128	151	×
	I	LASER POWER LOW (K1)	Used to set the laser power (Low speed/K1)	0 - 255	128	151	×
	J	LASER POWER LOW (K2)	Used to set the laser power (Low speed/K2)	0 - 255	128	151	×
	K	LASER POWER LOW (C1)	Used to set the laser power (Low speed/C1)	0 - 255	128	151	×
	L	LASER POWER LOW (C2)	Used to set the laser power (Low speed/C2)	0 - 255	128	151	×
	M	LASER POWER LOW (M1)	Used to set the laser power (Low speed/M1)	0 - 255	128	151	×
	N	LASER POWER LOW (M2)	Used to set the laser power (Low speed/M2)	0 - 255	128	151	×
	O	LASER POWER LOW (Y1)	Used to set the laser power (Low speed/Y1)	0 - 255	128	151	×
	P	LASER POWER LOW (Y2)	Used to set the laser power (Low speed/Y2)	0 - 255	128	151	×
	Q	LASER POWER MIDDLE (BW1)	Used to set the laser power (Middle speed/BW1)	0 - 255	128	151	×
	R	LASER POWER MIDDLE (BW2)	Used to set the laser power (Middle speed/BW2)	0 - 255	128	151	×
	S	LASER POWER LOW (BW1)	Used to set the laser power (Low speed/BW1)	0 - 255	128	151	×
	T	LASER POWER LOW (BW2)	Used to set the laser power (Low speed/BW2)	0 - 255	128	151	×
U	LASER DUTY MIDDLE (K)	Laser DUTY select middle speed (K)	0 - 255	0	0	○	

Mode	Item/Display		Content	Setting range	Default value		Destination linkage
					26cpm/31cpm(A) machine	36cpm machine	
PR1200	V	LASER DUTY MIDDLE (C)	Laser DUTY select middle speed (C)	0 - 255	0	0	○
	W	LASER DUTY MIDDLE (M)	Laser DUTY select middle speed (M)	0 - 255	0	0	○
	X	LASER DUTY MIDDLE (Y)	Laser DUTY select middle speed (Y)	0 - 255	0	0	○
	Y	LASER DUTY LOW (K)	Laser DUTY select low speed (K)	0 - 255	0	0	○
	Z	LASER DUTY LOW (C)	Laser DUTY select low speed (C)	0 - 255	0	0	○
	AA	LASER DUTY LOW (M)	Laser DUTY select low speed (M)	0 - 255	0	0	○
	AB	LASER DUTY LOW (Y)	Laser DUTY select low speed (Y)	0 - 255	0	0	○
	AC	LASER DUTY MIDDLE(BW)	Laser DUTY select middle speed (BW)	0 - 255	0	0	○
AD	LASER DUTY LOW (BW)	Laser DUTY select low speed (BW)	0 - 255	0	0	○	

<b>61-4</b>	
<b>Purpose</b>	Adjustment
<b>Function (Purpose)</b>	Used to print the print image skew adjustment pattern. (LSU unit)
<b>Section</b>	

#### Operation/Procedure

- 1) Select a target item with scroll key on the touch panel.
- 2) Enter the print conditions setting value with 10-key.
- 3) Press [EXECUTE] key.

The print image skew adjustment pattern is printed.

Item/Display		Content		Default value	
A	MULTICOUNT	Print quantity (1-999)		1	
B	PAPER	MFT selection	1	Manual paper feed	2 (Paper feed tray 1)
			2	Paper feed tray 1	
			3	Paper feed tray 2	
			4	Paper feed tray 3	
			5	Paper feed tray 4	
			6	LCC	

## 62

<b>62-1</b>	
<b>Purpose</b>	Data clear
<b>Function (Purpose)</b>	Used to format the hard disk/SD Card. (HDD: Excluding the Operation manual and the watermark data) (SD Card: User data)
<b>Section</b>	

#### Operation/Procedure

- 1) Press [EXECUTE] key.
- 2) Press [YES] key.

Used to execute the HDD/SD Card format.

When the operation is completed, [EXECUTE] key returns to the normal display.

<b>62-2</b>	
<b>Purpose</b>	Operation test/check
<b>Function (Purpose)</b>	Used to check read/write of the hard disk (partial).
<b>Section</b>	

#### Operation/Procedure

- 1) Press [EXECUTE] key.
- 2) Press [YES] key.

<b>62-3</b>	
<b>Purpose</b>	Operation test/check
<b>Function (Purpose)</b>	Used to check read/write of the hard disk (all areas).
<b>Section</b>	

#### Operation/Procedure

- 1) Press [EXECUTE] key.
  - 2) Press [YES] key.
- Read/write operations are performed.

<b>62-6</b>	
<b>Purpose</b>	Operation test/check
<b>Function (Purpose)</b>	Used to perform the self diagnostics of the hard disk.
<b>Section</b>	

#### Operation/Procedure

- 1) Select the self diag area.
  - 2) Press [EXECUTE] key.
- The self diag operation is performed.

### Note

E7-03 error occurs. If there may be a trouble in the HDD, use this simulation to check the HDD.

SHORT S.T	Partial area diag
EXTENDED S.T	All area diag

When the operation is completed, [EXECUTE] key returns to the normal display.

Normal completion → "OK (RESULT:0)" is displayed.

Abnormal end → "NG (RESULT: Other than 0)" is displayed.

\* If the simulation cannot be executed or terminated abnormally for some reason, "ERROR" is displayed on the corresponding section.

<b>62-7</b>	
<b>Purpose</b>	Operation test/check
<b>Function (Purpose)</b>	Used to print the hard disk self diagnostics error log.
<b>Section</b>	

#### Operation/Procedure

- 1) Press [EXECUTE] key.
- ERROR LOG SECTOR of the SMART function is executed, and the result is printed.
- When the operation is completed, [EXECUTE] key returns to the normal display.

<b>62-8</b>	
<b>Purpose</b>	Data clear
<b>Function (Purpose)</b>	Used to format the hard disk/SD Card. (HDD: Excluding the Operation Manual, the watermark data, and the system area) (SD Card: User data)
<b>Section</b>	
<b>Operation/Procedure</b>	
1) Press [EXECUTE] key.	
2) Press [YES] key.	
Used to execute the hard disk format.	
When the operation is completed, [EXECUTE] key returns to the normal display.	
* When the HDD formatting (except for the system area) is not completed normally, "HDD FORMAT (EXCEPT SYSTEM AREA) NG" is displayed.	

<b>62-10</b>	
<b>Purpose</b>	Data clear
<b>Function (Purpose)</b>	Used to clear the job completion list data.
<b>Section</b>	
<b>Operation/Procedure</b>	
1) Press [EXECUTE] key.	
2) Press [YES] key.	
Used to delete the job log data.	
When the operation is completed, [EXECUTE] key returns to the normal display.	

<b>62-11</b>	
<b>Purpose</b>	Data clear
<b>Function (Purpose)</b>	Used to delete the document filing data.
<b>Section</b>	
<b>Operation/Procedure</b>	
1) Press [EXECUTE] key.	
2) Press [YES] key.	
Used to delete the document filing data.	
When the operation is completed, [EXECUTE] key returns to the normal display.	

<b>62-12</b>	
<b>Purpose</b>	Setting
<b>Function (Purpose)</b>	Used to set Enable/Disable of auto format in a hard disk trouble.
<b>Section</b>	
<b>Operation/Procedure</b>	
1) Enter the set value with 10-key.	
2) Press [OK] key.	
The set value is saved.	
When it is set to Enable, if a read error of HDD occurs in the system data storage area (FAX/device cloning data, etc.), only the system data storage area is cleared.	

A	0	Enable
	1	Disable (Default)

<b>62-13</b>	
<b>Purpose</b>	Data clear
<b>Function (Purpose)</b>	Used to format the hard disk. (Operation Manual, watermark data only)
<b>Section</b>	
<b>Operation/Procedure</b>	
1) Press [EXECUTE] key.	
2) Press [YES] key.	
The operation manual data are deleted.	
When the operation is completed, [EXECUTE] key returns to the normal display.	

<b>62-14</b>	
<b>Purpose</b>	Data clear
<b>Function (Purpose)</b>	Used to delete the document filing management data.
<b>Section</b>	HDD
<b>Operation/Procedure</b>	
1) Press [EXECUTE] key.	
2) Press [YES] key.	
The document filing management data are cleared.	
At the same time, the job log data are also cleared.	
This simulation is executed in the following trouble cases.	
* The document filing function does not work normally.	
* The job log is not recorded normally.	

**Note**

This simulation may not function with some firmware versions. In such a case, the firmware must be upgraded to the latest version.

<b>62-15</b>	
<b>Purpose</b>	Data conversion
<b>Function (Purpose)</b>	Used to convert the setting data for document filing reprint.
<b>Section</b>	MFP
<b>Operation/Procedure</b>	
Press [EXECUTE] key.	
Conversion of the setting data for document filing reprint is started. When the procedure is completed, "EXECUTE" button returns to the normal display.	
<b>Description:</b>	
The document filing data made in a machine of the 26cpm/31cpm/36 cpm machine with the ICU firmware version 00.28.A1 or before cannot be reprinted under the environment of the ICU firmware version 01.00.A1 or later.	
To solve this problem, use this simulation to convert the document filing data made under the older firmware into those for the new firmware, enabling reprinting.	
Be sure to execute this simulation when the ICU firmware version is upgraded from 00.28.A1 or before to 01.00.A1 or later.	

**62-20**

**Purpose** Operation test/check

**Function (Purpose)** Used to check the operation of the mirroring hard disk. (26cpm/36cpm/31cpm(A) machine)

**Section** Mirroring hard disk

**Operation/Procedure**

Enter the simulation mode, and the operation status of the HDD is displayed.

The status display is renewed in every second.

Display	Content description
OK	Normal operation
NONE	Not connected
REBUILDING	Data rebuilding
ERROR	Error occurrence
TROUBLE	Trouble

**63**

**63-1**

**Purpose** Adjustment/Setting/Operation data check

**Function (Purpose)** Used to display the shading correction result.

**Section** Scanner

**Operation/Procedure**

- 1) Select a target color to display with [R] [G] [B] on the touch panel.

**[RSPF]**

Item/Display	Content	NOTE
GAIN ODD	Gain adjustment value (odd number)	
GAIN EVEN	Gain adjustment value (Even number)	
OFFSET ODD	Offset value (odd number)	
OFFSET EVEN	Offset value (even number)	
SMP AVE ODD	Reference plate sampling average value (ODD)	
SMP AVE EVEN	Reference plate sampling average value (EVEN)	
TARGET VALUE	Target value	
BLACK LEVEL	Black output level	

Item/Display	Content	NOTE	
ERROR CODE	Error code (0, 1-14) (for debug)	0	No error
		1	Loop number over
		2	The target value is under the specified value.
		3	The gain set value is negative.
		4	END is not asserted. (Gain adjustment)
		5	(reserve)
		6	Underflow
		7	Black shading error
		8	Other error
		9	END is not asserted. (White shading)
		10	END is not asserted. (Black shading)
		11	END is not asserted. (Light quantity correction)
		12	END is not asserted. (Scan)
		13	Register check error. (When booting/ Before gain)
14	Register check error. (Before light quantity correction)		
RSPF WHITE LEVEL 1ST	First scan RSPF white reference level		
RSPF WHITE LEVEL 2ND	Second scan RSPF white reference level		

**63-2**

**Purpose** Adjustment

**Function (Purpose)** Used to perform shading.

**Section**

**Operation/Procedure**

- 1) (When RSPF model)

Press [EXECUTE] key.

Used to perform shading.

When the operation is completed, [EXECUTE] key returns to the normal display.

**63-3**

**Purpose** Adjustment

**Function (Purpose)** Used to perform scanner (CCD) color balance and gamma auto adjustment.

**Section** Scanner

**Operation/Procedure**

- 1) Place the SIT chart (UKOG-0280FCZZ or UKOG-0280FCZ1) on the reference position of the left rear frame side of the document table.
- 2) Press [EXECUTE] key.  
The scanner (CCD) color balance automatic adjustment is performed.

When the operation is completed, [EXECUTE] key returns to the normal display.

After completion of the operation, press [RESULT] key, and the adjustment data are displayed. At that time, the target color of data display can be selected with [R] [G] [B] key.

63-4

<b>Purpose</b>	Adjustment/Setting/Operation data check
<b>Function (Purpose)</b>	Used to display the SIT chart patch density.
<b>Section</b>	

**Operation/Procedure**

- 1) Set the SIT chart (UKOG-0280FCZZ or UKOG-0280FCZ1) to the reference position on the left rear frame side of the document table.
- 2) Press [EXECUTE] key.  
The patch of the SIT chart is scanned.  
When the operation is completed, [EXECUTE] key returns to the normal display.
- 3) Select a data display mode.

THROUGH GAMMA	SIT chart scan data
COPY GAMMA	Copy mode gamma process data of the SIT chart scan data
SCANNER GAMMA	Image send mode gamma process data of the SIT chart scan data
SIT CHECK	SIT chart scan data/Check result

Select an target display color with [R] [G] [B] keys.

63-5

<b>Purpose</b>	Adjustment/Setup
<b>Function (Purpose)</b>	Used to perform the scanner (CCD) color balance and gamma default setting.
<b>Section</b>	

**Operation/Procedure**

- 1) Press [EXECUTE] key, and press [YES] key
- 2) The scanner (CCD) color balance and gamma are set to the default.

63-6

<b>Purpose</b>	Adjustment/Setting/Operation data check
<b>Function (Purpose)</b>	Used to display the scan level and the density level of the copy color balance adjustment patch.
<b>Section</b>	

**Operation/Procedure**

- 1) Set the color balance adjustment pattern sheet printed with SIM46-21 on the document table.
- 2) Press [EXECUTE] key.  
The patch image of the adjustment pattern sheet is scanned.  
Select a target color with [C] [M] [Y] [K] key.

63-7

<b>Purpose</b>	Adjustment/Setup
<b>Function (Purpose)</b>	Used to register the service target of the copy mode auto color balance adjustment.
<b>Section</b>	

**Operation/Procedure**

- 1) Press [SETUP] key on the touch panel.
- 2) Set the color balance adjustment pattern sheet printed with SIM46-21 on the document table.
- 3) Press [EXECUTE] key.  
The patch image of the adjustment pattern sheet is scanned.
- 4) Press [OK] key.  
The service target of the copy mode automatic color balance adjustment is registered according to the patch image of the scanned adjustment pattern sheet.  
The registered color balance and the density are displayed.  
Select a target color with [C] [M] [Y] [K] key.

**Important**

This simulation is executed only when the copy color balance is manually adjusted.

B	Point B target value
C	Point C target value
D	Point D target value
E	Point E target value
F	Point F target value
G	Point G target value
H	Point H target value
I	Point I target value
J	Point J target value
K	Point K target value
L	Point L target value
M	Point M target value
N	Point N target value
O	Point O target value
BASE	Background sampling value

63-8

<b>Purpose</b>	Adjustment/Setup
<b>Function (Purpose)</b>	Used to set the default of the service target of the copy mode auto color balance adjustment.
<b>Section</b>	

**Operation/Procedure**

- 1) Press [EXECUTE] key.
- 2) Press [YES] key.  
The service target of the copy mode automatic color balance adjustment is set to the default.  
The service color balance target and the color balance target for the user color balance adjustment are set to the same color balance as the factory color balance target.

63-11

<b>Purpose</b>	Adjustment/Setup
<b>Function (Purpose)</b>	Used to set the target color balance of the copy mode auto color balance adjustment.
<b>Section</b>	

**Operation/Procedure**

- 1) Select the target color balance with the touch panel.

Item/Display	Content	Default value
Target color balance	DEF1	The engine color balance adjustment target in the automatic color balance operation is slightly shifted to Magenta. When this target is selected, the color balance is converted into natural gray color balance by the color table in an actual copy mode and print is made.
	DEF2	The engine color balance adjustment target in the automatic color balance operation is slightly shifted to natural gray color balance. When this target is selected, the color balance is slightly shifted to Cyan by the color table in an actual copy mode and print is made.
	DEF3	The engine color balance adjustment target in the automatic color balance operation is slightly shifted to Cyan. When this target is selected, the color balance is converted into the color balance with enhanced Cyan by the color table in an actual copy mode and print is made.
		DEF 1

64-1	
<b>Purpose</b>	Operation test/check
<b>Function (Purpose)</b>	Test print. (Self print) (Color mode)
<b>Section</b>	

**Operation/Procedure**

- 1) Set the print conditions.
  - Select an item to be print condition with scroll keys.
  - Set the print conditions with 10-key.
  - Select a target print color with [K] [C] [M] [Y] key.
- 2) Press [EXECUTE] key.
  - The test print (self print) is performed.

Item/Display		Content		Setting range		Default value	
A	PRINT PATTERN (1, 2, 9 - 11, 17 - 19, 21, 22, 29)	Specification of the print pattern (* For details, refer to the description below.)		1 - 58 (Printable only 1, 2, 9 - 11, 17 - 19, 21, 22, 29)		1	
B	DOT1 (DOT1>=2 IF A: 2,11)	Setting of print dot number (M parameter) (Self print pattern: m by n)		1-255 (Pattern 2, 11: 2-255 except above: 1-255)		1	
C	DOT2 (DOT2>=2 IF A: 2,11)	Setting of blank dot number (N parameter) (Self print pattern: m by n)		0-255 (Pattern2, 11: 2-255 except above: 0-255)		254	
D	DENSITY (FIXED "255" IF A: 9)	Used to specify the print gradation.		1-255 (Pattern 9: 255 Fixed except above:1-255)		255	
E	MULTI COUNT	Number of print		1 - 999		1	
F	EXPOSURE (2 - 8 IF A: 17 - 19)	THROUGH	Exposure mode specification	No process (through)	1-8 (Pattern 17-19: 2-8 except above:1-8)	1	8 (STANDARD DITHER)
		CHAR/PIC		Text/Printed Photo		2	
		CHAR/PRPIC		Text/ Photograph		3	
		CHAR		Text		4	
		PRINT PIC		Printed Photo		5	
		PRINT PAPER		Photograph		6	
		MAP		Map		7	
		STANDARD DITHER		Dither without correction		8	
G	PAPER	MFT	Tray selection	Manual paper feed	1 - 6	1	2 (CS1)
		CS1		Tray 1		2	
		CS2		Tray 2		3	
		CS3		Tray 3		4	
		CS4		Tray 4		5	
		LCC		LCC		6	
H	DUPLEX	YES	Duplex print selection	Yes	0 - 1	0	1 (NO)
		NO		No		1	
I	PAPER TYPE	PLAIN	Paper type	Standard paper	1 - 6	1	1 (PLAIN)
		HEAVY		Heavy paper		2	
		OHP		OHP		3	
		ENVELOPE		Envelope		4	
		HEAVY2		Heavy paper 2		5	
		GLOSSY		Glossy paper		6	

**Print pattern of Item A**

Pattern No.	Content	Pattern generating section	NOTE
1	Grid pattern	LSU-ASIC	<ul style="list-style-type: none"> <li>When the print width is 100 or more and all colors are selected, print is made in the three colors (CMY).</li> <li>Print is started at 4mm from the paper lead edge.</li> <li>Writing regardless of pound. The first one is fixed to LD1.</li> </ul>
2	Dot print		-
9	Each color 10% area (A4/A4R) density print		<ul style="list-style-type: none"> <li>Each interval is 41.86mm (989dot).</li> <li>If m is not in the range of 1 - 13%, it is rounded.</li> <li>K print is started at 17mm from the paper lead edge.</li> </ul>
10	8-color belt print		
11	4-color dot print (sub scan)		<ul style="list-style-type: none"> <li>For every 1/4 of the sub scanning direction paper size, print is made for each color.</li> <li>When N=0, print of all the background is made in 4 colors.</li> </ul>
17	All background (halftone)	Halftone (IMG-ASIC rear process)	<ul style="list-style-type: none"> <li>When all colors are selected, print is made in CMY.</li> </ul>
18	256 gradations pattern (Other dither)		<ul style="list-style-type: none"> <li>When all colors are selected, print is made in CMY.</li> <li>16 gradations are printed in the main scanning direction, and feedback is made, and the next 16 gradations are printed. (16 x 16 patch print)</li> <li>Print is started at 5mm from the paper lead edge.</li> <li>Print is made from 255 gradations, and 0-254 gradations are printed.</li> </ul>
19	256 gradations pattern (For text dither)		<ul style="list-style-type: none"> <li>Print is made from 255 gradations, and 0-254 gradations are printed.</li> </ul>

Pattern No.	Content	Pattern generating section	NOTE
21	4-point dot print (main scan)	LSU-ASIC	<ul style="list-style-type: none"> <li>For every 1/4 of the main scanning direction paper size, print is made for each color.</li> <li>When N=0, print of all the background is made in 4 colors.</li> </ul>
22	Slant line	LSU-ASIC	
29 (26cpm/36cpm/ 31cpm(A) machine)	Dot print 1200dpi	LSU-ASIC	M = 1 (Fixed), N = 1 or 3

<b>64-2</b>	
<b>Purpose</b>	Operation test/check
<b>Function (Purpose)</b>	Test print. (Self print) (Monochrome mode)
<b>Section</b>	

#### Operation/Procedure

- Set the print conditions.
  - Select an item to be print condition with scroll keys.
  - Set the print conditions with 10-key.
- Press [EXECUTE] key.
  - The test print (self print) is performed.

Item/Display		Content		Setting range	Default value	
A	PRINT PATTERN (1, 2, 9 - 11, 17 - 19, 21, 22, 29)	Print pattern specification (* For details, refer to the description below.)		1 - 58 (Printable only 1, 2, 9 - 11, 17 - 19, 21, 22, 29)	1	
B	DOT1 (DOT1>=2 IF A: 2,11)	Setting of print dot number (M parameter) (Self print pattern: m by n)		1-255 (Pattern 2, 11: 2-255 except above: 1-255)	1	
C	DOT2 (DOT2>=2 IF A: 2,11)	Setting of blank dot number (N parameter) (Self print pattern: m by n)		0-255 (Pattern2, 11: 2-255 except above: 0-255)	254	
D	DENSITY (FIXED "255" IF A: 9)	Used to specify the print gradation.		1-255 (Pattern 9: 255 Fixed except above:1-255)	255	
E	MULTI COUNT	Number of print		1 - 999	1	
F	EXPOSURE (2 - 8 IF A: 17 - 19)	THROUGH	Exposure mode specification	No process (through)	1	8 (STANDARD DITHER)
		CHAR/PIC		Text/Printed Photo	2	
		CHAR/PRPIC		Text/ Photograph	3	
		CHAR		Text	4	
		PRINT PIC		Printed Photo	5	
		PRINT PAPER		Photograph	6	
		MAP		Map	7	
		STANDARD DITHER		Dither without correction	8	
G	PAPER	MFT	Tray selection	Manual paper feed	1	2 (CS1)
		CS1		Tray 1	2	
		CS2		Tray 2	3	
		CS3		Tray 3	4	
		CS4		Tray 4	5	
		LCC		LCC	6	
H	DUPLEX	YES	Duplex print selection	Yes	0	1 (NO)
		NO		No	1	
I	PAPER TYPE	PLAIN	Paper type	Standard paper	1	1 (PLAIN)
		HEAVY		Heavy paper	2	
		OHP		OHP	3	
		ENVELOPE		Envelope	4	
		HEAVY2		Heavy paper 2	5	
		GLOSSY		Glossy paper	6	

#### Print pattern of Item A

Pattern No.	Content	Pattern generating section	NOTE
1	Grid pattern	LSU-ASIC	<ul style="list-style-type: none"> <li>When the print width is 100 or more and all colors are selected, print is made in the three colors (CMY).</li> <li>Print is started at 4mm from the paper lead edge.</li> <li>Writing regardless of pound. The first one is fixed to LD1.</li> </ul>
2	Dot print		-
9	Each color 10% area (A4/A4R) density print		<ul style="list-style-type: none"> <li>Each interval is 41.86mm (989dot).</li> <li>If m is not in the range of 1 - 13%, it is rounded.</li> <li>K print is started at 17mm from the paper lead edge.</li> </ul>
10	8-color belt print		
11	4-color dot print (sub scan)		<ul style="list-style-type: none"> <li>For every 1/4 of the sub scanning direction paper size, print is made for each color.</li> <li>When N=0, print of all the background is made in 4 colors.</li> </ul>



Pattern No.	Content	Pattern generating section	NOTE
17	All background (halftone)	Halftone (IMG-ASIC rear process)	-
18	256 gradations pattern (Other dither)		-
19	256 gradations pattern (For text dither)		-
21	4-point dot print (main scan)	LSU-ASIC	<ul style="list-style-type: none"> <li>For every 1/4 of the main scanning direction paper size, print is made for each color.</li> <li>When N=0, print of all the background is made in 4 colors.</li> </ul>
22	Slant line	LSU-ASIC	
29 (26cpm/36cpm/ 31cpm(A) machine)	Dot print 1200dpi	LSU-ASIC	M = 1 (Fixed), N = 1 or 3

<b>64-4</b>	
<b>Purpose</b>	Operation test/check
<b>Function (Purpose)</b>	Printer test print. (Self print)
<b>Section</b>	

#### Operation/Procedure

- Set the print conditions.
  - Select an item to be print condition with scroll keys.
  - Set the print conditions with 10-key.
  - Select a target print color with [K] [C] [M] [Y] key.
- Press [EXECUTE] key.
- The test print (self print) is performed.

Item/Display		Content		Setting range	Default value	
A	PRINT PATTERN	Specification of the print pattern (* For details, refer to the description below.)		1 - 6	6	
B	DENSITY	Used to specify the print gradation.		1 - 255	128	
C	MULTI COUNT	Number of print		1 - 999	1	
D	PAPER	MFT	Paper feed tray selection	Manual paper feed	1	3 (CS2)
		CS1		Tray 1	2	
		CS2		Tray 2	3	
		CS3		Tray 3	4	
		CS4		Tray 4	5	
		LCC		LCC	6	
E	HALFTONE	LOW	Halftone	Low line number	0	0 (LOW)
		HIGH		High line number	1	
		GLOSSY		Glossy paper	2	
F	QUALITY	STANDARD	Image quality setting	Standard	0	1 (HIGHQUALITY)
		HIGHQUALITY		High quality	1	
		FINE		Fine (26cpm/36cpm/31cpm(A) machine)	2	
G	DITHER	STRAIGHT	Specification of dither correction	Straight	0	1 (CALIB)
		CALIB		Calibration	1	
H	PAPER TYPE	PLAIN	Paper type	Standard paper	0	0
		HEAVY		Heavy paper	1	
		HEAVY2		Heavy paper 2	2	
		GLOSSY		Glossy paper	3	

#### Print pattern of Item A

Pattern No.	Content
1	256 gradations pattern (COLOR)
2	256 gradations pattern (B/W)
3	256 gradations pattern (COLOR) (Y-M-C-K continuous)
4	Halftone pattern (COLOR)
5	Halftone pattern (B/W)
6	Background dot print

<b>Purpose</b>	Operation test/check
<b>Function (Purpose)</b>	Printer test print. (Self print) (PCL)
<b>Section</b>	

**Operation/Procedure**

- Set the print conditions.
  - Select an item to be print condition with scroll keys.
  - Set the print conditions with 10-key.
  - Select a target print color with [K] [C] [M] [Y] key.
- Press [EXECUTE] key.
  - The test print (self print) is performed.

Item/Display		Content		Setting range	Default value	
A	PRINT PATTERN	Print pattern specification		1 - 5	3	
B	DENSITY	Print gradation specification		1 - 255	255	
C	MULTI COUNT	Number of print		1 - 999	1	
D	PAPER	MFT	Paper feed tray selection	Manual paper feed	1	2 (CS1)
		CS1		Tray 1	2	
		CS2		Tray 2	3	
		CS3		Tray 3	4	
		CS4		Tray 4	5	
		LCC		LCC	6	
E	HALFTONE	LOW(IMAGE)	Halftone	For Photo	0	3 (AUTO)
		HIGH(TEXT)		For text	1	
		GLOSSY		For glossy paper	2	
		AUTO		Auto (for photo/text)	3	
F	QUALITY	STANDARD	Image quality setting	Standard (600dpi, 1bit)	0	1 (HIGHQUALITY)
		HIGHQUALITY		High quality (600dpi, 4bit)	1	
		FINE		Fine (1200dpi, 1bit) (26cpm/36cpm/31cpm(A) machine)	2	
G	DITHER	STRAIGHT	Specification of dither correction	0: Straight	0	1
		CALIB		1: Calibration	1	
H	PAPER TYPE	PLAIN	Paper type	Standard paper	0	0 (PLAIN)
		HEAVY		Heavy paper	1	
		HEAVY2		Heavy paper 2	2	
		GLOSSY		Glossy paper	3	
I	INTENT	PERCEPTUAL	Rendering indent	Perceptual	0	0 (PERCEPTUAL)
		COLORIMETRIC		Color metric	1	
		SATURATION		Saturation	2	
J	OUTPUT PROFILE	SHARP	Output profile	Standard	0	0 (SHARP)
		STANDARD		Photo image	1	
		GRAPHICS		Graphics	2	
K	RGB SOURCE PROFILE	SRGB	RGB source profile	SRGB	0	0 (SRGB)
		GAMMA1.6		Gamma 1.6	1	
		GAMMA1.8		Gamma 1.8	2	
		GAMMA2.0		Gamma 2.0	3	
		GAMMA2.6		Gamma 2.6	4	
		GAMMA3.0		Gamma 3.0	5	
L	GRAY COMPENSATION	K	Gray print method	Print method K	0	0 (K)
		KCMY		KCMY	1	
M	PURE BLACK PRINT	ON	Black monochrome print	set.	0	0 (ON)
		OFF		not set.	1	
N	TONER SAVE MODE	OFF	Monochrome toner save	not set.	0	0 (OFF)
		ON		set.	1	

**Print pattern of Item A**

Pattern No.	Content
1	COLOR
2	B/W
3	Continuous COLOR,B/W
4	Service chart (COLOR)
5	Service chart (B/W)

<b>Purpose</b>	Operation test/check
<b>Function (Purpose)</b>	Printer test print. (Self print) (PS)
<b>Section</b>	

**Operation/Procedure**

- Set the print conditions.
  - Select an item to be print condition with scroll keys.
  - Set the print conditions with 10-key.
  - Select a print color with [K] [C] [M] [Y] key.
- Press [EXECUTE] key.
  - The test print (self print) is performed.

Item/Display		Content		Setting range	Default value
A	PRINT PATTERN	Print pattern specification		1 - 2	1
B	DENSITY	Print gradation specification		1 - 255	255
C	MULTI COUNT	Number of print		1 - 999	1
D	PAPER	MFT	Paper feed tray selection	Manual paper feed	2 (CS1)
		CS1		Tray 1	
		CS2		Tray 2	
		CS3		Tray 3	
		CS4		Tray 4	
		LCC		LCC	
E	HALFTONE	LOW(IMAGE)	Halftone	For Photo	3 (AUTO)
		HIGH(TEXT)		For text	
		GLOSSY		For glossy paper	
		AUTO		Auto (for photo/text)	
F	QUALITY	STANDARD	Image quality setting	Standard (600dpi, 1bit)	1 (HIGHQUALITY)
		HIGHQUALITY		High quality (600dpi, 4bit)	
		FINE		Fine (1200dpi, 1bit) (26cpm/36cpm/31cpm(A) machine)	
G	DITHER	STRAIGHT	Specification of dither correction	0: Straight	1 (CALIB)
		CALIB		1: Calibration	
H	PAPER TYPE	PLAIN	Paper type	Standard paper	0 (PLAIN)
		HEAVY		Heavy paper	
		HEAVY2		Heavy paper 2	
		GLOSSY		Glossy paper	
I	INTENT	PERCEPTUAL	Rendering indent	Perceptual	0 (PERCEPTUAL)
		COLORIMETRIC		Color metric	
		SATURATION		Saturation	
J	OUTPUT PROFILE	SHARP	Output profile	Standard	0 (SHARP)
		STANDARD		Photo image	
		GRAPHICS		Graphics	
K	RGB SOURCE PROFILE	SRGB	RGB source profile	SRGB	0 (SRGB)
		GAMMA1.6		Gamma 1.6	
		GAMMA1.8		Gamma 1.8	
		GAMMA2.0		Gamma 2.0	
		GAMMA2.6		Gamma 2.6	
		GAMMA3.0		Gamma 3.0	
		TONER SAVE		For TONER SAVE	
L	GRAY COMPENSATION	K	Gray print method	Print method K only	0 (K)
		KCMY		KCMY	
M	PURE BLACK PRINT	ON	Black monochrome print	set.	0 (ON)
		OFF		not set.	
N	TONER SAVE MODE	OFF	Monochrome toner save	not set.	0 (OFF)
		ON		set.	
O	CMY SIMULATION	OFF	CMYK simulation	OFF	0 (OFF)
		SWOP		SWOP	
		EURO		EURO	
		JAPAN COLOR		JAPAN COLOR	
		TONER SAVE		For TONER SAVE	

**Print pattern of Item A**

Pattern No.	Content
1	COLOR
2	B/W

64-7

<b>Purpose</b>	Operation test/check
<b>Function (Purpose)</b>	Used to print the adjustment pattern of the test print. (Self print). (The adjustment pattern of SIM46-21 is printed.)

**Section**

**Operation/Procedure**

- Set the print conditions.  
 Select an item to be print condition with scroll keys.  
 Set the print conditions with 10-key.
- Press [EXECUTE] key.  
 The adjustment pattern of SIM46-21 is printed.

Item/Display	Content		Setting range	Default value	Writing	
A	COPIES	Number of print	1 - 999	1	No	
B	PROC ADJ	YES	0	0 - 1	1	Yes
		NO	1			

**65**

65-1

<b>Purpose</b>	Adjustment
<b>Function (Purpose)</b>	Used to adjust the touch panel (LCD display section) detection coordinates.
<b>Section</b>	Operation panel section

**Operation/Procedure**

Touch the center of the cross mark at the four corners of the screen.

When the adjustment is completed normally, the screen shifts to the simulation sub number entry menu.

In case of an error, the screen returns to the adjustment menu.

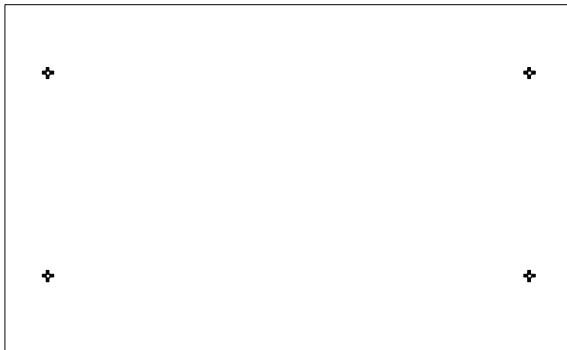

65-2

<b>Purpose</b>	Operation check/test
<b>Function (Purpose)</b>	Used to display the touch panel (LCD display section) detection coordinates.

**Section**

**Operation/Procedure**

Touch the touch panel.

The coordinates X (horizontal direction) and Y (vertical direction) of the touched position is displayed in real time.

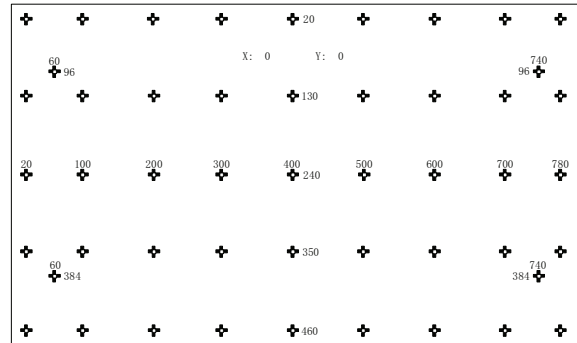

65-5

<b>Purpose</b>	Operation check/test
<b>Function (Purpose)</b>	Used to check the operation panel key input.

**Section**

**Operation/Procedure**

Press the keys sequentially according to the guidance displayed on the screen.

If the key entry is effective, the guidance for pressing the next key is displayed. When all the key entries are completed, "COMPLETE" is displayed.

**<Check target key>**

7 Inch LCD model
JOB STATUS
SYSTEM SETTINGS
HOME
1
2
3
4
5
6
7
8
9
AUDIT CLEAR
0
PROGRAM
CLEAR
STOP
CLEAR ALL/RESET
START (COLOR)
START (MONO)

10 Inch LCD model
HOME

## 66-1

<b>Purpose</b>	Setting
<b>Function (Purpose)</b>	Used to display the FAX-related soft SW (2 - 150) on the LCD to allow changing the soft SW while checking with the LCD.
<b>Section</b>	FAX

**Operation/Procedure**

- Enter the [SW NO] with 10-key.
  - \* When [C] key is pressed, the entered value of [SW NO] is cleared.
- Press [DATA] button.  
The soft SW data entered in procedure 1) is displayed.
  - \* When [SW NO] button is pressed, the display returns to the initial screen.
- Enter the number corresponding to the bit to be changed with 10-key.
  - \* [1] → [0]
  - [0] → [1]
- When [EXECUTE] button is pressed, it is highlighted and the setting is saved.  
After saving the setting, [EXECUTE] button returns to the normal display.

## 66-2

<b>Purpose</b>	Setting
<b>Function (Purpose)</b>	Used to enter a country code and set the default value for the country code.
<b>Section</b>	FAX

**Operation/Procedure**

- When the machine enters Simulation 66-02, the following screen is displayed.
  - \* When [DEST CODE] button is pressed, the display is shifted to the country code list screen.
  - \* The currently set country code is displayed in the column of "PRESENT:".
- Enter the country code (8 digits) with 10-key([0]/[1]). The entered country code is displayed in the column of "NEW:" and [SET] key becomes active.
  - \* When [C] key is pressed, the column of "NEW:" is cleared.
- When [SET] button is pressed after entering the country code, [EXECUTE] button becomes active. The country code is displayed in the column of "PRESENT:", and the column of "NEW:" is cleared.
- When [EXECUTE] button is pressed, it is highlighted and [YES] and [NO] buttons become active. The country name is displayed on the tile line.
- When [YES] button is pressed, it is highlighted and the soft SW corresponding to the country code is initialized.
- After completion of initialization of the soft SW, [EXECUTE], [YES], and [NO] buttons become inactive.

**Operation/Procedure (Shifting to the country page)**

- \* When [DEST CODE] button is pressed on the initial screen, the display is shifted to the country code list screen.  
Use scroll keys to select the country select page.

## &lt;Country code list&gt;

JAPAN	00000000
U.S.A.	10110101
AUSTRALIA	00001001
U.K.	10110100
FRANCE	00111101
GERMANY	00000100
SWEDEN	10100101
NEWZEALAND	01111110
CHINA	00100110
SINGAPORE	10011100
TW	11111110
MIDDLEANDNEAREAST	11111101
SLOVAKIA	11111100
OTHER3	11110111
FINLAND	00111100
NORWAY	10000010
DENMARK	00110001
NETHERLANDS	01111011
ITALY	01011001
SWITZERLAND	10100110
AUSTRIA	00001010
INDONESIA	01010100
THAILAND	10101001
MALAYSIA	01101100
INDIA	01010011
PHILIPPINES	10001001
HONGKONG	01010000
RUSSIA	10111000
SOUTHAFRICA	10011111
SPAIN	10100000
PORTUGUESE	10001011
LUXEMBURG	01101001
BELGIUM	00001111
CZECH	00101110
HUNGARY	01010001
GREECE	01000110
POLAND	10001010
BRAZIL	00010110

## 66-3

<b>Purpose</b>	Operation test/Check
<b>Function (Purpose)</b>	Used to check read/write of the EEPROM and the SDRAM on the MODEM controller and display the result.
<b>Section</b>	FAX

**Operation/Procedure**

- When the machine enters Simulation 66-03, the following screen is displayed.
  - \* Select the page of memory check item with the scroll key.
- When the memory check item button is selected, the display is shifted to the memory check screen.
- When [EXECUTE] button is pressed, it is highlighted and the memory check of the selected item is started.
- After completion of memory check, [EXECUTE] button returns to the normal display and the result of memory check is displayed.

**Memory check status**

NO CHECK	No check	
CHECKING	During checking	
OK	Check complete OK	
NG A##	Check complete NG	Error occurring address or data line is displayed for each item.

**Check item**

	Check memory item	Remark
1	All Memory Device Check (once)	All the items are checked once.
2	MFP SRAM (once) *1	Check only once
3	MFP SRAM (repeat) *1	Repeat check
4	MFP FLASH + OP.FLASH (once) *1	Check only once
5	MFP FLASH + OP.FLASH (repeat) *1	Repeat check
6	MODEM EEPROM <1> (once)	Check only once in LINE1
7	MODEM EEPROM <1> (repeat)	Repeat check in LINE1
8	MODEM SDRAM <1> (once)	Check only once in LINE1
9	MODEM SDRAM<1>(repeat)	Repeat check in LINE1

The number in < > indicates the line.

\*1: This function does not operated in the 26cpm/36cpm/31cpm(A) machines.

**66-4**

**Purpose** Operation test/Check

**Function (Purpose)** Used to send the selected signals to the line and the main unit speaker. (Send level: max.)

**Section** FAX

**Operation/Procedure**

- When the machine enters Simulation 66-04, the screen on the right is displayed. (Default, left upper selected.)  
\* Use scroll keys to switch the send mode select page.
- When a button of a signal to be sent is selected, it is highlighted and the previously set button is shifted to the normal display.
- When [EXECUTE] button is pressed, it is highlighted and signals are sent.
- To end signal send:  
When [EXECUTE] button is pressed, it is highlighted and signal send is interrupted.

**<Signal send table>**

NOSIGNAL	33.6 V34	31.2 V34	28.8 V34
26.4 V34	24.0 V34	21.6 V34	19.2 V34
16.8 V34	14.4 V34	12.0 V34	9.6 V34
7.2 V34	4.8 V34	2.4 V34	14.4 V33
12.0 V33	14.4 V17	12.0 V17	9.6 V17
7.2 V17	9.6 V29	7.2 V29	4.8 V27t
2.4 V27t	0.3 FLG	CED 2100	CNG 1100
0.3 V21	ANSam	RINGER	No RBT

DP MAKE	DP BRK	NO MSG
---------	--------	--------

**66-5**

**Purpose** Operation test/Check

**Function (Purpose)** Used to send the selected signal to the line and the main unit speaker. (Send level: Soft SW setting) (For the kinds of send signals, refer to SIM66-04.)

**Section** FAX

**Operation/Procedure**

- When the machine enters Simulation 66-05, the following screen is displayed.  
\* Use scroll keys to switch the send mode select page.
- When a button of a signal to be sent is selected, it is highlighted and the previously set button is shifted to the normal display.
- When [EXECUTE] button is pressed, it is highlighted and signals are sent.
- To end signal send:  
\* When [EXECUTE] button is pressed, it is highlighted and signal send is interrupted.

**66-6**

**Purpose** Data output/Check

**Function (Purpose)** Used to print the confidential registration check table (BOX NO., BOX name, pass-code. (If there is no confidential registration, no print is made.)

**Section** FAX

**Operation/Procedure**

- When [EXECUTE] button is pressed, it is highlighted and the confidential checkable is printed.  
\* If there is no confidential registration, no print is made even though [EXECUTE] key is pressed.
- After completion of printing, [EXECUTE] button returns to the normal display.

**66-7**

**Purpose** Data output/Check

**Function (Purpose)** Used to output all image data saved in the image memory. (Confidential data are also outputted.)

**Section** FAX

**Operation/Procedure**

- When [EXECUTE] button is pressed, it is highlighted and all image data saved in the image memory are outputted.
- After completion of printing, [EXECUTE] button returns to the normal display.

**66-8**

**Purpose** Operation test/Check

**Function (Purpose)** Used to send the selected sound messages to the line and the speaker. (Send level: Max.)

**Section** FAX

**Operation/Procedure**

- When the machine enters Simulation 66-08, the following screen is displayed.
- When the sound message button to be sent is selected, it is highlighted and the previously set button returns to the normal display.

**<Sound message table>**

NONE (Mute)	PAUSE (Pause melody)	MESSAGE1 (Message 1)	MESSAGE2 (Message 2)
MESSAGE3 (Message 3)	MESSAGE4 (Message 4)	MESSAGE5 (Message 5)	MESSAGE6 (Message 6)
ALARM (Alarm)	RINGER (Ringing sound (Speaker))	EXT.TEL.RING (External telephone call)	

**66-9**

<b>Purpose</b>	Operation test/Check
<b>Function (Purpose)</b>	Used to send the selected sound message to the line and the speaker. (Send level: Soft SW setting) * For details of sound messages, refer to the sound message table of SIM66-08.
<b>Section</b>	FAX

**Operation/Procedure**

- 1) When the machine enters Simulation 66-09, the following screen is displayed.
- 2) When a button of a sound message to be sent is selected, it is highlighted and the previously set button returns to the normal display.
- 3) When [EXECUTE] button is pressed, it is highlighted and a sound message is sent.
- 4) To end signal send:  
When [EXECUTE] button is pressed, it is highlighted and signal send is interrupted.

**66-10**

<b>Purpose</b>	Data clear
<b>Function (Purpose)</b>	Used to clear the FAX and image send image data. (The confidential data are also cleared.)
<b>Section</b>	FAX

**Operation/Procedure**

- 1) Press [EXECUTE] button.
- 2) Press [YES] button.
- 3) After completion of clearing, press [CA] key to reboot the machine.

**66-11**

<b>Purpose</b>	Operation test/Check
<b>Function (Purpose)</b>	Used to send the selected signal at 300bps to the line and the speaker. (Send level: Max.)
<b>Section</b>	FAX

**Operation/Procedure**

- 1) When the machine enters Simulation 66-11, the following screen is displayed.
- 2) When a button of a sound message to be sent is selected, it is highlighted and the previously set button returns to the normal display.
- 3) When [EXECUTE] button is pressed, it is highlighted and a sound message is sent.
- 4) To end signal send:  
When [EXECUTE] button is pressed, it is highlighted and signal send is interrupted.

**<300bps send signal table>**

NO SIGNAL	11111	11110	00000
010101	00001		

**66-12**

<b>Purpose</b>	Operation test/Check
<b>Function (Purpose)</b>	Used to send the selected signal at 300bps to the line and the speaker. (Send level: Soft SW setting) * For the kings of send signals at 300bps, refer to SIM66-11, 300bps send signal table.
<b>Section</b>	FAX

**Operation/Procedure**

- 1) When the machine enters Simulation 66-12, the following screen is displayed.
- 2) When a button of a sound message to be sent is selected, it is highlighted and the previously set button returns to the normal display.
- 3) When [EXECUTE] button is pressed, it is highlighted and a sound message is sent.
- 4) To end signal send:  
When [EXECUTE] button is pressed, it is highlighted and signal send is interrupted.

**66-13**

<b>Purpose</b>	Setting
<b>Function (Purpose)</b>	Used to register dial numbers for SIM66-14/15/16, Dial test. (Up to 20 digits can be registered.)
<b>Section</b>	FAX

**Operation/Procedure**

- 1) When the machine enters Simulation 66-13, the following screen is displayed.  
\* The number saved in the memory is displayed in the column of [PRESENT:]. (If there is no data, [-----] is displayed.)
- 2) Enter a number with 10-key.  
The entered number is displayed in the column of [NEW:].  
After entering 20 digits, 10-key is disabled (no response). Only [C] key is enabled. (10-key [0] to [9], [\*], [#], [C] key (back by one digit))
- 3) When [SET] key is pressed after completion of entry, the entered number is displayed (registered) in the column of [PRESENT:]. The column of [NEW:] becomes blank.

**66-14**

<b>Purpose</b>	Adjustment
<b>Function (Purpose)</b>	Used to execute the dial pulse (10PPS) send test and to adjust the make time.
<b>Section</b>	FAX

**Operation/Procedure**

- 1) When the machine enters Simulation 66-14, the following screen is displayed.
- 2) When [EXECUTE] button is pressed, it is highlighted and the dial pulse is sent from the line in the set make time.
- 3) To end the dial test, press [EXECUTE] button again. The button returns to the normal display and the test is terminated.

**66-15****Purpose** Adjustment**Function (Purpose)** Used to execute the dial pulse (20PPS) send test and to adjust the make time.**Section** FAX**Operation/Procedure**

- 1) When the machine enters Simulation 66-15, the following screen is displayed.
- 2) When [EXECUTE] button is pressed, it is highlighted and the dial pulse is sent from the line in the set make time.  
\* The dial pulse in this example is up to 20 digits registered with SIM66-13.
- 3) To end the dial test, press [EXECUTE] button again. The button returns to the normal display and the test is terminated.

**66-16****Purpose** Adjustment**Function (Purpose)** Used to execute the DTFM signal send test and to adjust the send level.**Section** FAX**Operation/Procedure**

- 1) When the machine enters Simulation 66-16, the following screen is displayed.
- 2) When [EXECUTE] button is pressed, it is highlighted and the dial pulse signal is sent from the line by the setting of high/low group of the signal send level.
- 3) To terminate the dial test, press [EXECUTE] button. The button returns to the normal display and the test is terminated.

**66-17****Purpose** Operation test/Check**Function (Purpose)** Used to send the DTMF signal to the line and the speaker. (Send level: Max.)**Section** FAX**Operation/Procedure**

- 1) When the machine enters Simulation 66-17, the following screen is displayed.
- 2) When a button of a send signal is selected, it is highlighted and the previously set button returns to the normal display.
- 3) When [EXECUTE] button is pressed, it is highlighted and signals are sent.
- 4) To stop signal sending:  
When [EXECUTE] button is pressed, it returns to the normal display and signal sending is interrupted.

**66-18****Purpose** Operation test/Check**Function (Purpose)** Used to send the DTMF signal to the line and the speaker. (Send level: Soft SW setting)**Section** FAX**Operation/Procedure**

- 1) When the machine enters Simulation 66-18, the following screen is displayed.
- 2) When a button of a send signal is selected, it is highlighted and the previously set button returns to the normal display.
- 3) When [EXECUTE] button is pressed, it is highlighted and signals are sent.
- 4) To stop signal sending:  
When [EXECUTE] button is pressed, it returns to the normal display and signal sending is interrupted.

**66-21****Purpose** Check**Function (Purpose)** Used to print the selected items (system error, protocol monitor).**Section** FAX**Operation/Procedure**

- 1) When an item button to be printed is selected, it is highlighted and the previously set button returns to the normal display.
- 2) Press [EXECUTE] button.  
[EXECUTE] button is highlighted and printing is started.
- 3) After completion of printing, [EXECUTE] button returns to the normal display.

**<FAX information print content table>**

PROTOCOL LINE 1	SYSTEM ERROR LINE 1
-----------------	---------------------

**66-22****Purpose** Setting**Function (Purpose)** Used to set the handset sound volume. (This simulation can be executed even though the handset setting is set to NO. When, however, the handset is not installed, the sound volume cannot be checked.) (Japan model only)**Section** FAX**Operation/Procedure**

- 1) When the machine enters the simulation, the number of the set sound volume is displayed. (In this example, MIDDLE is set as the default sound volume.)
- 2) Use 10-key to set the handset sound volume. (0: MIN 1:MIDDLE 2:MAX)
- 3) Press [EXECUTE] button to deliver the selected on-hold tone.  
\* If, however, the handset is not installed, the sound volume cannot be checked. Execution is possible.
- 4) When [EXECUTE] button is pressed, it is highlighted and delivery of the on-hold tone is stopped.

**66-24****Purpose** Data clear**Function (Purpose)** Used to clear the FAST save data.**Section** FAX**Operation/Procedure**

- 1) Press [EXECUTE] button.
- 2) Press [YES] button.  
The FAST save data are cleared.
- 3) After completion of memory clear, [EXECUTE] button returns to the normal display and [YES] and [NO] buttons gray out.



<b>66-29</b>	
<b>Purpose</b>	Clear
<b>Function (Purpose)</b>	Used to initialize the telephone book data (the one-touch registration table, the FTP/Desktop expansion table, the group expansion table, the program registration table, the interface memory box table, the meta data, InboundRouting, and the DocumentAdmin table).

**Section** FAX

**Operation/Procedure**

- 1) Press [EXECUTE] button.
- 2) Press [YES] button.  
The telephone book data area cleared.
- 3) After completion of memory clear, [EXECUTE] button returns to the normal display and [YES] and [NO] buttons gray out.

<b>66-30</b>	
<b>Purpose</b>	Operation test/Check
<b>Function (Purpose)</b>	Used to display the TEL/LIU status change, The display is highlighted by status change.

**Section** FAX

**Operation/Procedure**

- 1) When the machine enters Simulation 66-30, the following screen is displayed.
- 2) HS1, HS2, RHS, and EXHS are highlighted when the signal is detected, and displayed normally when the signal is not detected.

**<TEL/LIU status change item description>**

HS1	Polarity inversion signal
HS2	Polarity inversion signal
RHS	Handset hook SW
EXHS	External telephone hook SW

<b>66-31</b>	
<b>Purpose</b>	Setting
<b>Function (Purpose)</b>	Used to set ON/OFF the port for output to TEL/LIU.

**Section** FAX

**Operation/Procedure**

- 1) When the machine enters Simulation 66-31, the following screen is displayed.
- 2) Change the port setting.  
When a port is set to ON, the port display is highlighted.
- 3) When [EXECUTE] button is pressed, the changed setting is reflected to the port which outputs to TEL/LIU.
- 4) To terminate the process, press [EXECUTE] button again.  
[EXECUTE] button returns to the normal display.

**<Port which outputs to TEL/LIU>**

CION	MR	EC	S.
------	----	----	----

<b>66-32</b>	
<b>Purpose</b>	Operation test/Check
<b>Function (Purpose)</b>	Used to check the fixed data received from the line and to display the result.

**Section** FAX

**Operation/Procedure**

- 1) Press [EXECUTE] button to check the fixed data received from the line. At that time, [EXECUTE] button is highlighted.
  - \* Fixed data check procedure
    - The data received from the line is checked of the following fixed data status for minutes, then if they are in accord with "OK" is displayed on LCD, if not "NG" is displayed.
    - The judgment is made in 2 minutes.  
Receive speed: 300BPS  
Receive data: 00H  
Judgment data: 100byte
- 2) After completion of check, [EXECUTE] button returns to the normal display. The result is displayed as "OK" or "NG."

<b>66-33</b>	
<b>Purpose</b>	Operation test/Check
<b>Function (Purpose)</b>	Used to execute detection of various signals with the line connected and to display the detection result. When a signal is detected, the display is highlighted.

**Section** FAX

**Operation/Procedure**

- 1) When the machine enters Simulation 66-33, the following screen is displayed.
- 2) The signal to be checked can be selected from the two options: "FNET" and "BT/CNG/CED/DTMF."
- 3) When a signal is detected, "FNET" and "BUSY TONE CNG CED DTMF" are highlighted. When a signal is not detected, they are normally displayed.

**<Signal used for signal detection check>**

**(When "FNET" is selected)**

FNET
------

**(When "BT/CNG/CED/DTMF" is selected)**

BUSY TONE	CNG	CED	DTMF
-----------	-----	-----	------

<b>66-34</b>	
<b>Purpose</b>	Operation test/Check
<b>Function (Purpose)</b>	Used to execute the send test and display the time required for sending image data in the test. Used to execute send test and display. (Unit: ms)

**Section** FAX

**Operation/Procedure**

- 1) FAX send is performed.
- 2) Enter the SIM 66-34 mode.  
The send time in procedure 1) is displayed.

66-36

<b>Purpose</b>	Operation test/Check
<b>Function (Purpose)</b>	Used to check send and receive data from the MODEM controller to the MFP controller or the data line or the command line individually.
<b>Section</b>	FAX

**Operation/Procedure**

- When the machine enters Simulation 66-36, the following screen is displayed.
- Operation check  
Select an item to be checked on the screen.

**<MFP controller I/F check item table>**

MFP ← MDMC (DATA once) Data line Once	MFP → MDMC (DATA once) Data line Once
MFP ← MDMC (DATA repeat) Data line Repeat	MFP → MDMC (DATA repeat) Data line Repeat
MFP ← MDMC (CMD once) Command line Once	MFP → MDMC (CMD once) Command line Once
MFP ← MDMC (CMD repeat) Command line Repeat	MFP → MDMC (CMD repeat) Command line Repeat

66-39

<b>Purpose</b>	Setting
<b>Function (Purpose)</b>	Used to check and change the destination setting saved in EEPROM of the FAX BOX.
<b>Section</b>	FAX

**Operation/Procedure**

- When the machine enters the simulation, the currently set destination button is highlighted. (In the default state, JAPAN is set as the destination.)
- Select a destination button to set the destination. (In this example, USA/CANADA is selected.) The selected button is highlighted and the previously selected button returns to the normal display.  
\* When the destination button is changed, the new destination setting is saved to EEPROM of the FAX BOX.

**<Destination setting table>**

JAPAN	U.S.A/CANADA	EUROPE	AUSTRALIA
CHINA	ASIA&OTHERS		

66-42

<b>Purpose</b>	Setting
<b>Function (Purpose)</b>	Used to rewrite the program to power control installed in the FAX BOX.
<b>Section</b>	FAX

**Operation/Procedure**

- Press [EXECUTE] button.[EXECUTE] button is highlighted and [YES] and [NO] buttons become active.
- Press [YES] button.  
The power control program is rewritten.
- When rewriting of the power control program is normally completed, "OK" is displayed and [EXECUTE] button returns to the normal display, and [YES] and [NO] buttons gray out.

66-43

<b>Purpose</b>	Setting
<b>Function (Purpose)</b>	Used to write the adjustment value into the power control installed in the FAX BOX.
<b>Section</b>	FAX

**Operation/Procedure**

- When the machine enters Simulation 66-43, the following screen is displayed.  
\* Use scroll keys to select the select item of the power control adjustment value.
- When [EXECUTE] key is pressed, it is highlighted and writing to the power control is executed. When writing is normally completed, "OK" is displayed. When it is failed, "NG" is displayed.
- After completion of writing, [EXECUTE] key returns to the normal display.

**<Set range and default value of each set value>**

	Item	Set range	Default value
A	CI_LEVEL_JUDGE	2 to 15	6
B	CI_CYCLE_MIN	1 to 254	10
C	CI_CYCLE_MAX	2 to 255	142
D	CI_COUNT	2 to 15	3
E	RES_3.3V_LEVEL_JUDGE	2 to 15	15
F	EXHS_LEVEL_JUDGE	2 to 225	240
G	RHS_LEVEL_JUDGE	2 to 15	2
H	SON_TIMEOUT	1 to 127	20

66-61

<b>Purpose</b>	Setting
<b>Function (Purpose)</b>	Used to display the FAX-related soft SW (151 - 250) on the LCD to allow changing the soft SW while checking with the LCD.
<b>Section</b>	FAX

**Operation/Procedure**

- Enter the [SW NO] with 10-key.
- Press [DATA] button.  
The soft SW data entered in procedure 1) is displayed.
- Enter the number corresponding to the bit to be changed with 10-key.  
\* [1] → [0]  
[0] → [1]
- When [EXECUTE] button is pressed, it is highlighted and the setting is saved.

66-62

<b>Purpose</b>	Backup
<b>Function (Purpose)</b>	Used to import the FAX receive data into a USB memory in PDF file type.
<b>Section</b>	FAX

**Operation/Procedure**

- Insert the USB memory into the main unit.
- Select data to be imported.
- Press [EXECUTE] key.  
Execute import of data selected in procedure 2).  
When the operation is completed normally, [COMPLETE] is displayed. In case of an abnormal end, [ERROR] is displayed.

Error display	Content
ERROR: NO USB MEMORY DEVICE	No USB memory installed
ERROR: NO IMAGE DATA	No image data
ERROR	Other errors

# 67

## 67-17

<b>Purpose</b>	Reset
<b>Function (Purpose)</b>	Printer reset
<b>Section</b>	Printer

### Operation/Procedure

- 1) Press [EXECUTE] key.
- 2) Press [YES] key.  
The set data related to the printer are initialized. (Including the NIC setting.)

When the operation is completed, [EXECUTE] key returns to the normal display.

## 67-24

<b>Purpose</b>	Adjustment/Setup
<b>Function (Purpose)</b>	Printer color balance adjustment (Auto adjustment)
<b>Section</b>	Printer

### Operation/Procedure

- 1) Press [EXECUTE] key.  
The color patch image (adjustment pattern) is printed out.
- 2) Plate the printed adjustment pattern on the document table, select [FACTORY] or [SERVICE] mode.
- 3) Press [EXECUTE] key.  
The printer color balance auto adjustment is performed, and the adjustment result is printed.
- 4) Press [OK] key.  
The halftone correction target registration is processed.

## 67-25

<b>Purpose</b>	Adjustment/Setup
<b>Function (Purpose)</b>	Printer color balance adjustment (Manual adjustment)
<b>Section</b>	Printer

### Operation/Procedure

- 1) Select an adjustment target color with [K][C][M][Y] keys on the touch panel.
- 2) Select a target adjustment density level with scroll key on the touch panel.
- 3) Enter the set value with 10-key.  
\* When the  $\Delta$   $\nabla$  key is pressed, the setting value of each item can be changed with 1up (1down) collectively.
- 4) Press [OK] key. (The set value is saved.)

When the adjustment value is increased, the image density is increased, and vice versa.

When [EXECUTE] key is pressed, the check pattern in printed in the color balance and density corresponding to the adjustment value.

	Item/Display	Setting range	Default value
A	POINT1	1 - 999	500
B	POINT2	1 - 999	500
C	POINT3	1 - 999	500
D	POINT4	1 - 999	500
E	POINT5	1 - 999	500
F	POINT6	1 - 999	500
G	POINT7	1 - 999	500
H	POINT8	1 - 999	500
I	POINT9	1 - 999	500
J	POINT10	1 - 999	500
K	POINT11	1 - 999	500
L	POINT12	1 - 999	500
M	POINT13	1 - 999	500
N	POINT14	1 - 999	500
O	POINT15	1 - 999	500
P	POINT16	1 - 999	500
Q	POINT17	1 - 999	500

## 67-26

<b>Purpose</b>	Adjustment/Setup
<b>Function (Purpose)</b>	Used to set the target color balance of the printer mode auto color balance adjustment.
<b>Section</b>	Printer

### Operation/Procedure

- 1) Select the target color balance with the touch panel.

Item/Display	Content	Default value
Target value table select	DEF1	The engine color balance adjustment target in the automatic color balance operation is slightly shifted to Magenta. When this target is selected, the color balance is converted into natural gray color balance by the color table in an actual printer mode and print is made.
	DEF2	The engine color balance adjustment target in the automatic color balance operation is slightly shifted to natural gray color balance. When this target is selected, the color balance is slightly shifted to Cyan by the color table in an actual copy mode and print is made.
	DEF3	The engine color balance adjustment target in the automatic color balance operation is slightly shifted to Cyan. When this target is selected, the color balance is converted into the color balance with enhanced Cyan by the color table in an actual copy mode and print is made.
		DEF 1

67-27

<b>Purpose</b>	Adjustment/Setup
<b>Function (Purpose)</b>	Used to set the service target of the printer mode auto color balance adjustment.

<b>Section</b>	Printer
----------------	---------

**Operation/Procedure**

- 1) Press [SETUP] key on the touch panel.
- 2) Place the printed color balance adjustment pattern sheet printed in SIM 67-25 on the document table.
- 3) Press [EXECUTE] key.  
The patch image of the adjustment pattern sheet is scanned.
- 4) Press [OK] key.

The service target of the printer mode auto color balance adjustment is set according to the scanned adjustment pattern sheet patch images.

The registered color balance and the density are displayed.

Select a target color with [C] [M] [Y] [K] key.

**Important**

This simulation is executed only when the printer color balance is manually adjusted.

B	Point B target value
C	Point C target value
D	Point D target value
E	Point E target value
F	Point F target value
G	Point G target value
H	Point H target value
I	Point I target value
J	Point J target value
K	Point K target value
L	Point L target value
M	Point M target value
N	Point N target value
O	Point O target value
BASE	Background sampling value

67-28

<b>Purpose</b>	Adjustment/Setup
<b>Function (Purpose)</b>	Used to set the default of the service target of the printer mode auto color balance adjustment.

<b>Section</b>	Printer
----------------	---------

**Operation/Procedure**

- 1) Press [EXECUTE] key.
- 2) Press [YES] key.

The service target of the printer mode auto color balance adjustment is set to the default.

The service color balance target and the color balance target for the user color balance adjustment are set to the same color balance as the factory color balance target.

67-31

<b>Purpose</b>	Data clear
<b>Function (Purpose)</b>	Used to clear the printer calibration value.
<b>Section</b>	Printer

**Operation/Procedure**

- 1) Press [EXECUTE] key.
- 2) Press [YES] key.

The printer calibration data (Halftone correction data) are cleared.

(The printer color balance correction is canceled.)

67-33

<b>Purpose</b>	Adjustment/Setup
<b>Function (Purpose)</b>	Used to change the gamma of the printer screen.

<b>Section</b>	Printer
----------------	---------

**Operation/Procedure**

- 1) Select a target change color with [K] [C] [M] [Y] key on the touch panel.
- 2) Select a target screen with [SCREEN] key.
- 3) Select a target adjustment density level with scroll key.
- 4) Enter the set value with 10-key.
- 5) Press [OK] key. (The set value is saved.)

When [EXECUTE] key is pressed, the check pattern in printed in the color balance and density corresponding to the adjustment value.

However, check pattern print-out cannot be made in the GDI printer mode. (Only the adjustment can be made.)

Item/Display	Content	Setting range	Default value
A	POINT1	Point 1	0 - 255 128
B	POINT2	Point 2	0 - 255 128
C	POINT3	Point 3	0 - 255 128
D	POINT4	Point 4	0 - 255 128
E	POINT5	Point 5	0 - 255 128
F	POINT6	Point 6	0 - 255 128
G	POINT7	Point 7	0 - 255 128
H	POINT8	Point 8	0 - 255 128
I	POINT9	Point 9	0 - 255 128
J	POINT10	Point 10	0 - 255 128
K	POINT11	Point 11	0 - 255 128
L	POINT12	Point 12	0 - 255 128
M	POINT13	Point 13	0 - 255 128
N	POINT14	Point 14	0 - 255 128
O	POINT15	Point 15	0 - 255 128
P	POINT16	Point 16	0 - 255 128
Q	POINT17	Point 17	0 - 255 128

**18cpm/20cpm/23cpm/31cpm(G) machine****PCL/PS printer**

Display	Content
SCREEN1	600dpi 1bit Photo
SCREEN2	600dpi 1 bit Graphics
SCREEN3	600dpi 4 bit Photo
SCREEN4	600dpi 4 bit Graphics
SCREEN7	B/W 600dpi 1 bit
SCREEN8	B/W 600dpi 4 bit
SCREEN10	Gloss 600dpi 4bit
HEAVY PAPER	Printer paper kind manual gamma correction (Heavy paper)

**GDI printer**

Display	Content	Button
SCREEN1	600dpi 1bit Low (Photo)	CMYK
SCREEN2	600dpi 1bit High (Graphics)	CMYK
SCREEN3	600dpi 2bit Low (Photo)	CMYK
SCREEN4	600dpi 2bit High (Graphics)	CMYK
SCREEN5	B/W 600dpi 1bit	K
SCREEN6	B/W 600dpi 2bit Low (Photo)	K
SCREEN7	B/W 600dpi 2bit High (Graphics)	K
SCREEN8	Gloss 600dpi 1bit	CMYK
SCREEN9	Gloss 600dpi 2bit	CMYK

**26cpm/36cpm/31cpm(A) machine**

Display	Content
HEAVY PAPER	Heavy paper
SCREEN1	600dpi 1bit Photo
SCREEN2	600dpi 1bit Graphics
SCREEN3	600dpi 4bit Photo
SCREEN4	600dpi 4bit Graphics
SCREEN5	1200dpi 1bit Photo
SCREEN6	1200dpi 1bit Graphics
SCREEN7	B/W 600 dpi 1bit
SCREEN8	B/W 600 dpi 4bit
SCREEN9	B/W 1200dpi 1bit
SCREEN10	Gloss 600 dpi 4bit

<b>67-34</b>	
<b>Purpose</b>	Adjustment/Setup
<b>Function (Purpose)</b>	Used to set the density correction in the printer high density section. (Support for the high density section tone gap)
<b>Section</b>	Printer

**Operation/Procedure**

- 1) Enter the set value with 10-key.

0	Enable
1	Disable

- 2) Press [OK] key. (The set value is saved.)

Item/Display	Content	Setting range	Default value		
A	CMY (0: ENABLE 1: DISABLE)	0	CMY engine highest density correction mode: Enable	0 - 1	0
		1	CMY engine highest density correction mode: Disable		
B	K (0: ENABLE 1: DISABLE)	0	K engine highest density correction mode: Enable	0 - 1	1
		1	K engine highest density correction mode: Disable		
C	CYAN MAX TARGET	Scanner target value for CYAN maximum density correction		0 - 999	500
D	MAGENTA MAX TARGET	Scanner target value for MAGENTA maximum density correction		0 - 999	500
E	YELLOW MAX TARGET	Scanner target value for YELLOW maximum density correction		0 - 999	500
F	BLACK MAX TARGET	Scanner target value for BLACK maximum density correction		0 - 999	500

- When tone gap is generated in the high density section, set items A and B to "0."  
The density in the high density section is decreased, but tone gap is reduced.
- To increase the density in the high density section further, set items A and B to "1."  
The tone gap may occur in high density part.

**Important**

Do not change the values of items C, D, E, and F. If these values are changed, the density in the high density area is changed.

<b>67-36</b>	
<b>Purpose</b>	Adjustment/Setup
<b>Function (Purpose)</b>	Used to adjust the density in the low density section.
<b>Section</b>	Printer

**Operation/Procedure**

- 1) Enter the adjustment value using the 10-key.
- 2) Press [OK] key.

When the adjustment value is increased, the low density images are strongly reduced. When the adjustment value is decreased, the low density are images are weakly reproduced.

When tone gap is generated in the low density section (highlight section), changing this adjustment value may improve the trouble.

Item/Display	Content	Setting range	Default value	
A	A PATCH INPUT	A patch input value	0 - 13	1

<b>67-45</b>	
<b>Purpose</b>	Adjustment/Setup
<b>Function (Purpose)</b>	Used to adjust the printer image filter and trapping.
<b>Section</b>	Printer

**Operation/Procedure**

- 1) Select an adjustment item with the scroll key.
- 2) Enter the set value.
- 3) Press [OK] key.

Item/Display	Content	Setting range	Default value	NOTE	
A	SHARPNESS: COLOR PRINT	Color print	0 - 4	2	The greater the set value is, the stronger the filter enhancement is. The smaller the set value is, the stronger the filter smoothness is. (0: Soft High, 1: Soft Low, 2: Center, 3: Sharp Low, 4: Sharp High)
B	SHARPNESS: B/W PRINT	Monochrome print	0 - 4	2	
C	TRAPPING: CMY (PCL & DIRECTPRINT)	CMY (PCL, Direct Print)	0 - 5	3	
D	TRAPPING: K (PCL & DIRECTPRINT)	K (PCL, Direct Print)	0 - 5	3	
E	TRAPPING: CMY (PS)	CMY (PS)	0 - 5	3	The greater the set value is, the stronger the trapping is. (0: OFF, (Low) 1 < 2 < 3 < 4 < 5) (The target is vector images. There is no effect for the raster images.) However, the sharpness also varies.
F	TRAPPING: K (PS)	K (PS)	0 - 5	0	
G	TRAPPING: CMY (XPS)	CMY (XPS)	0 - 5	0	
H	TRAPPING: K (XPS)	K (XPS)	0 - 5	0	

67-52

<b>Purpose</b>	Adjustment/Setup
<b>Function (Purpose)</b>	Used to set the default of the gamma of the printer screen.
<b>Section</b>	Printer

**Operation/Procedure**

- 1) Select a target default setting mode with the touch panel.  
Press [ALL] key to select all the modes.
- 2) Press [EXECUTE] key and press [YES] key.

When the printer screen gamma was changed by SIM 67-33, SIM67-54, it is reset to the default.

**18cpm/20cpm/23cpm/31cpm(G) machine****PCL/PS printer**

Item/Display		Content
Screen	HEAVYPAPER	Heavy paper screen
		Printer heavy paper automatic density correction amount
	600DPI_1BIT	SCREEN1 (600dpi 1bit Photo)
		SCREEN2 (600dpi 1bit Graphics)
	B/W	SCREEN7 (600dpi 1bit Graphics)
		SCREEN8 (600dpi 1bit Graphics)
		SCREEN9 (600dpi 1bit Graphics)
		Printer B/W toner save automatic density correction amount
	GLOSSPAPER	SCREEN10 (Glossy paper screen)

**GDI printer**

Item/Display		Content
Screen	600DPI_1BIT	SCREEN1 (600dpi 1bit Low (Photo))
		SCREEN2 (600dpi 1bit High (Graphics))
	B/W	SCREEN5 (B/W 600dpi 1bit)
		SCREEN6 (B/W 600dpi 2bit Low (Photo))
		SCREEN7 (B/W 600dpi 2bit High (Graphics))
	GLOSSPAPER	SCREEN8 (Gloss 600dpi 1bit)
		SCREEN9 (Gloss 600dpi 2bit)

**26cpm/36cpm/31cpm(A) machine**

Item/Display		Content
Screen	HEAVYPAPER	Heavy paper screen
		Printer heavy paper automatic density correction amount
	1200DPI_1BIT	SCREEN5 (1200dpi 1bit Photo)
		SCREEN6 (1200dpi 1bit Graphics)
	600DPI_1BIT	SCREEN1 (600dpi 1bit Photo)
		SCREEN2 (600dpi 1bit Graphics)
	B/W	SCREEN7 (600dpi 1bit Graphics)
		SCREEN8 (600dpi 1bit Graphics)
		SCREEN9 (600dpi 1bit Graphics)
		Printer B/W toner save automatic density correction amount
	GLOSSPAPER	SCREEN10 (Glossy paper screen)

67-54

<b>Purpose</b>	Adjustment
<b>Function (Purpose)</b>	Printer color balance adjustment (Automatic adjustment for each dither (The adjustment is disable in a GDI printer.))
<b>Section</b>	Printer

**Operation/Procedure**

This simulation is used to adjust the color balance, the density, and the gradation in the monochrome mode, the heavy paper mode, the 1200dpi mode, and the 600dpi 1bit mode.

This simulation is used to improve image quality in these modes and images.

- 1) Press [EXECUTE] key. (A3 or 11" x 17" paper is automatically selected.)  
The color patch image (adjustment pattern) is printed out.
- 2) Set the color patch image (adjustment pattern) printed in the procedure 1) on the document table so that the thin lines on the printed color patch image (adjustment pattern) are on the left side. Place 5 sheets of white paper on the printed color patch image (adjustment pattern).
- 3) Press [EXECUTE] key.  
The color balance adjustment is automatically performed.  
The adjustment pattern is printed out. Check it for any abnormality.
- 4) Press [OK] key.  
The list of the adjustment items (for each dither) is displayed.
- 5) Select an adjustment item (for each dither).

Select item (Mode)	Content
Heavy Paper	Adjustment item to improve the color balance in the heavy paper mode
B/W	Adjustment item to improve the density and gradation in the monochrome mode
Glossy	Adjustment item to improve the color balance in glossy paper mode
1200dpi 1bit	Adjustment item to improve the color balance in 1200dpi mode

- 6) Press [EXECUTE] key. (A3 or 11" x 17" paper is automatically selected.)  
The color patch image (adjustment pattern) is printed out.
- 7) Set the color patch image (adjustment pattern) printed in the procedure 6) on the document table so that the thin lines on the printed color patch image (adjustment pattern) are on the left side. Place 5 sheets of white paper on the printed color patch image (adjustment pattern).
- 8) Press [EXECUTE] key.  
The color balance adjustment is automatically performed, and the color balance check patch image is printed out.
- 9) When [OK] key is pressed, the adjustment result is registered and the adjustment mode is terminated. When [EXECUTE] key is pressed, the adjustment result is registered and the screen is shifted to the other item (Mode/Image) select menu.  
To execute the adjustment of the other item (Mode/Image), press [EXECUTE] key.  
After completion of all the adjustments of the items (Mode/Image), press [OK] key, and the adjustment results are registered.
- 10) Make a print, and check the print image quality.

**Note**

Use SIM67-52 to reset the adjustment values to the default values.

# [6] TROUBLESHOOTING

## 1. Error code and troubleshooting

### A. General

When a trouble occurs in the machine or when the life of a consumable part is nearly expired or when the life is expired, the machine detects and displays it on the display section. This allows the user and the serviceman to take the suitable action. In case of a trouble, this feature notifies the occurrence of a trouble and stops the machine to minimize the damage.

### B. Function and purpose

- 1) Securing safety. (The machine is stopped on detection of a trouble.)
- 2) The damage to the machine is minimized. (The machine is stopped on detection of a trouble.)
- 3) By displaying the trouble content, the trouble position can be quickly identified. (This allows to perform an accurate repair, improving the repair efficiency.)
- 4) Preliminary warning of running out of consumable parts allows to arrange for new parts in advance of running out. (This avoids stopping of the machine due to running out the a consumable part.)

### C. Self diag message kinds

The self diag messages are classified as shown in the table below.

Class 1	User	Warning of troubles which can be recovered by the user. (Paper jam, consumable part life expiration, etc.)
	Service	Warning of troubles which can be recovered only by a serviceman. (Motor trouble, maintenance, etc.)
	Others	-
Class 2	Warning	Warning to the user, not a machine trouble (Preliminary warning of life expiration of a consumable part, etc.)
	Trouble	Warning of a machine trouble. The machine is stopped.
	Others	-

### D. Self diag operation

The machine always monitors its own state.

When the machine recognizes a trouble, it stops the operation and displays the trouble message.

A warning message is displayed when a consumable part life is nearly expired or is expired.

When a warning message is displayed, the machine may be or may not be stopped.

The trouble messages and the warning messages are displayed by the LCD and lamp.

Some trouble messages are automatically cleared when the trouble is repaired. Some other troubles must be cleared by a simulation.

Some warning messages of consumable parts are automatically cleared when the trouble is repaired. Some other warning messages must be cleared by a simulation.

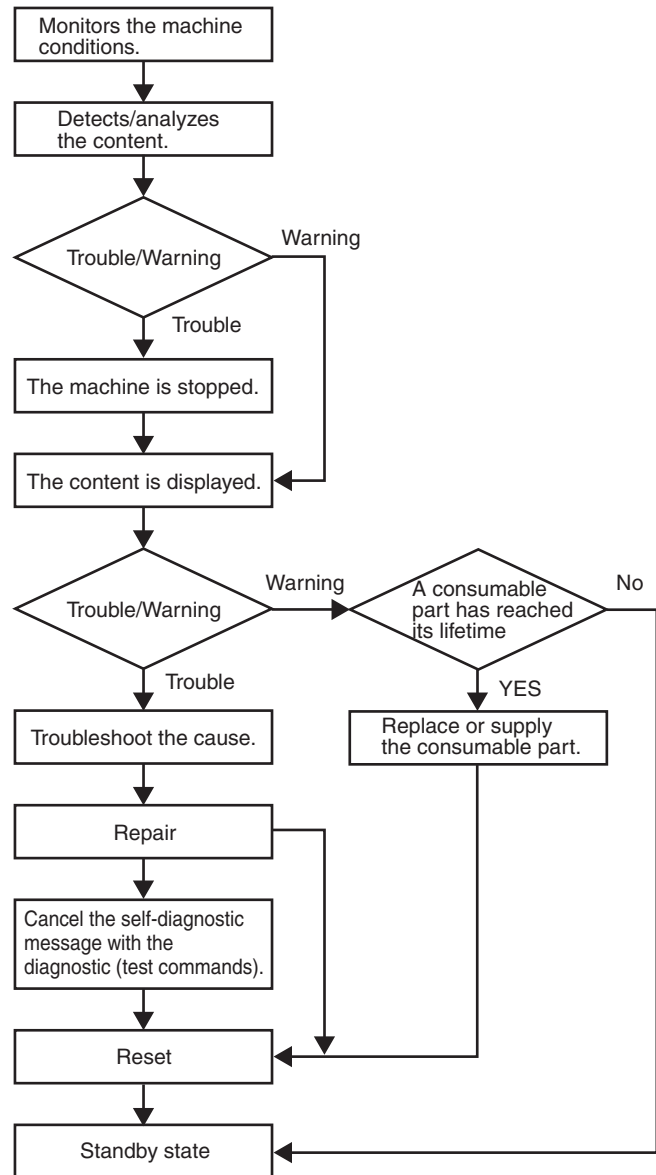

## E. Breakdown sequence

### (1) Error code and operatable mode

18cpm/20cpm machine

Trouble content		Judgment block	Trouble code (20cpm machine)	Operatable mode								FAST Notification to host	
				Copy scan (including interruption)	Scan (Push)	Scan (Pull)	Scan-To HDD	Print	List print	FAX Send	FAX print		
FAX board trouble	• FAX board breakdown	MFP	F6 (00, 01, 04, 21, 30, 97, 98)	○	○	○	○	○	○	-	-	-	
HDD trouble	• SD card breakdown		E7(07)	×	×	×	×	×	×	×	×	×	×
	• HDD breakdown		E7(03)	×	×	×	×	×	×	×	×	×	×
	• HDD-ASIC breakdown		E7(04)	×	×	×	×	×	×	×	×	×	×
Scanner communication trouble	• SCU communication error		A0(02) E7(80)	×	×	×	×	○	○	×	○	○	
Engine communication trouble	• PCU communication error		A0(01) E7(90)	×	×	×	×	×	×	×	×	○	
Option communication trouble	• ACU communication error		A0(04)	×	×	×	×	×	×	×	×	○	
Printer port system trouble	• Printer port system trouble		F9(91,92)	○	×	×	○	×	△	○	○	○	
Backup battery voltage fall trouble	• Backup battery voltage fall		U1(01)	×	×	×	×	×	×	×	×	○	
Operation disable trouble 1	• Controller fan trouble		L4(30)	×	×	×	×	×	×	×	×	×	
Operation disable trouble 2	• External serial I/F communication error (RIC)		U7(50,51)	×	×	×	×	×	×	×	×	○	
	• Memory error (included not installed the expansion RAM)		U2 (00, 05, 10, 11, 24, 40, 41, 42)	×	×	×	×	×	×	×	×	△15	
	• Connection trouble (Model data discrepancy) (MFPC detection)		A0 (10, 11, 15, 16, 20) E7 (60, 61, 65, 89)	×	×	×	×	×	×	×	×	×	
	• Serial number data error		U2 (30)	×	×	×	×	×	×	×	×	×	
	• HDD registration data check sum error		U2 (50)	×	×	×	×	×	×	×	×	○	
Operation disable trouble 3	• Memory check error when booting	E7 (95, 96)	×	×	×	×	×	×	×	×	○		
	• Image memory trouble, decode error	E7 (01, 91, 92, 93, 94)	×	×	×	×	×	×	×	×	○		
	• Image memory trouble, decode error (Image high compression)		×	△17	×	×	×	○	○	○	○		
Operation disable trouble 4	• Personal counter connection trouble	PC (00)	×	×	×	×	×	×	×	×	○		
Power controller trouble	• Power controller error	L8 (20)	×	×	×	×	×	×	×	×	○		
Special function trouble	• Watermark data error	P1 (00, 01, 02) U2 (60)	○	○	○	○	○	○	○	○	○		



Trouble content		Judgment block	Trouble code (20cpm machine)	Operatable mode										
				Copy scan (including interruption)	Scan (Push)	Scan (Pull)	Scan-To HDD	Print	List print	FAX Send	FAX print	FAST Notification to host		
Laser trouble	• LSU breakdown	PCU	E7 (20, 28, 29) L6 (10)	×	×	×	×	×	×	×	×	×	○	
Engine trouble 1	• Connection trouble (Model data discrepancy) (PCU detection)		A0 (21) E7 (50, 55) F1 (50)	×	×	×	×	×	×	×	×	×	×	×
Engine trouble 2	• PCU troubles (motor, fusing, etc.)		C1 (10,14) C4 (00) F2 (22, 40, 64, 70, 74, 91) H2 (00, 01, 02, 03) H3 (00, 01, 02) H4 (00, 01, 02) H5 (01) H7 (10) L4 (02, 03, 04, 05, 06, 11, 12, 16, 31, 32, 35, 43, 50, 51) L8 (01) U2 (90, 91)	×	×	×	×	×	×	×	×	×	×	○
Process system trouble	• LSU/Process system breakdown		E7 (21, 22, 23) F2 (23, 24, 25, 41, 42, 43, 65, 66, 67, 71, 72, 73, 75, 76, 77, 92, 93, 94)	×	×	×	×	×	×	×	×	×	×	○
Paper feed tray 1 trouble	• Paper feed tray 1 breakdown		F3 (12)	△3	○	○	○	△3	△3	○	△3	△3	○	○
Paper feed tray 2 trouble	• Paper feed tray 2 breakdown		F3 (22)	△3	○	○	○	△3	△3	○	△3	△3	○	○
Paper feed tray 3 trouble	• Paper feed tray 3 breakdown		U6 (01)	△3	○	○	○	△3	△3	○	△3	△3	○	○
Paper feed tray 4 trouble	• Paper feed tray 4 breakdown		U6 (02)	△3	○	○	○	△3	△3	○	△3	△3	○	○
Paper feed tray 5 trouble	• Paper feed tray 5 breakdown		U6 (52)	△3	○	○	○	△3	△3	○	△3	△3	○	○
Paper feed tray other troubles	• Paper feed tray other breakdown		U6 (00, 10, 50)	△11	○	○	○	△11	△11	○	△11	△11	○	○
Staple trouble	• Staple breakdown		F1 (08, 10)	△4	△4	△4	△4	△4	△4	△4	△4	△4	△4	○
Saddle stitch section trouble	• Saddle stitch section breakdown			△4	△4	△4	△4	△4	△4	△4	△4	△4	△4	○
Finisher trouble	• After-process breakdown		F1 (00, 03, 15, 19, 20, 21, 33, 34, 37)	△4	△4	△4	△4	△4	△4	△4	△4	△4	△4	○
Other troubles	• Other troubles		EE (EC, EL, EU)	○	○	○	○	○	○	○	○	○	○	○
Process control trouble	• Process control breakdown (PCU detection)		F2 (39, 49, 50, 51, 58, 78)	○	○	○	○	○	○	○	○	○	○	○
Operation disable trouble	• Connection trouble (Model data discrepancy) (SCU detection)	SCU	A0 (22)	×	×	×	×	×	×	×	×	×	×	
SCU CPT ASIC trouble	• SCU CPT ASIC error		UC (02)	△9	△9	△9	△9	○	○	△9	○	○	○	
SCU ASIC trouble (SCU detection)	• SCU ASIC error (SCU detection)		UC (20)	×	×	×	×	○	○	×	○	○	○	
Scanner trouble 1	• SCU EEPROM error		U2 (80, 81)	×	×	×	×	○	○	×	○	○	○	
Scanner trouble 2	• Scanner section breakdown (mirror motor, lens, copy lamp)		L1 (00) L3 (00)	×	×	×	×	○	○	×	○	○	○	
CCD trouble	• CCD breakdown (shading, etc.)		E7 (10, 11, 14)	×	×	×	×	○	○	×	○	○	○	

23cpm/26cpm/31cpm/36cpm machine

Trouble content		Judgment block	Trouble code (23cpm/31cpm(G) machine)	Trouble code (26cpm/36cpm/31cpm(A) machine)	Operatable mode									
					Copy scan (including interruption)	Scan (Push)	Scan (Pull)	Scan-To HDD	Print	List print	FAX Send	FAX print	FAST Notification to host	
FAX board trouble	• FAX board breakdown	MFP	F6 (00, 01, 04, 21, 30, 97, 98)	F6 (00, 01, 04, 21, 30, 97, 98)	○	○	○	○	○	○	-	-	-	
HDD trouble	• SD card breakdown		E7 (07)	E7 (07)	×	×	×	×	×	×	×	×	×	×
	• HDD breakdown		E7 (03)	E7 (03)	×	×	×	×	×	×	×	×	×	×
	• HDD-ASIC breakdown		E7 (04)	E7 (04)	×	×	×	×	×	×	×	×	×	×
Scanner communication trouble	• SCU communication error		A0 (02) E7 (80)	A0 (02) E7 (80)	×	×	×	×	○	○	×	○	○	
Engine communication trouble	• PCU communication error		A0 (01) E7 (90)	A0 (01) E7 (90)	×	×	×	×	×	×	×	×	○	
Option communication trouble	• ACU communication error		A0 (04)	A0 (04, 05)	×	×	×	×	×	×	×	×	○	
Printer port system trouble	• Printer port system trouble		F9 (91, 92)	F9 (91, 92)	○	×	×	○	×	△	○	○	○	
Backup battery voltage fall trouble	• Backup battery voltage fall		U1 (01)	U1 (01)	×	×	×	×	×	×	×	×	○	
Operation disable trouble 1	• Controller fan trouble		L4 (30)	L4 (30)	×	×	×	×	×	×	×	×	×	
Operation disable trouble 2	• External serial I/F communication error (RIC)		U7 (50, 51)	U7 (50, 51)	×	×	×	×	×	×	×	×	○	
	• Memory error (included not installed the expansion RAM)		U2 (00, 05, 10, 11, 24, 40, 41, 42)	U2 (00, 11, 40, 41, 42)	×	×	×	×	×	×	×	×	△15	
	• Connection trouble (Model data discrepancy) (MFPC detection)		A0 (10, 11, 15, 16, 20) E7 (60, 61, 65, 89)	A0 (10, 11, 14, 15, 16, 17, 20) E7 (60, 61, 65, 89)	×	×	×	×	×	×	×	×	×	
	• Serial number data error	U2 (30)	U2 (30)	×	×	×	×	×	×	×	×	×		
	• HDD registration data check sum error	U2 (50)	U2 (50)	×	×	×	×	×	×	×	×	○		
Operation disable trouble 3	• Memory check error when booting	E7 (95, 96)	E7 (95, 96)	×	×	×	×	×	×	×	×	○		
	• Image memory trouble, decode error	E7 (01, 49, 91, 92, 93, 94)	E7 (01, 49, 91, 92, 93, 94)	×	×	×	×	×	×	×	×	○		
	• Image memory trouble, decode error (Image high compression)		E7 (42, 46, 48)	×	△17	×	×	×	○	○	○	○		
Operation disable trouble 4	• Personal counter connection trouble	PC (00)	PC (00)	×	×	×	×	×	×	×	×	○		
Power controller trouble	• Power controller error	L8 (20)	L8 (20)	×	×	×	×	×	×	×	×	○		
Special function trouble	• Watermark data error	U2 (60) P1 (00, 01, 02)	U2 (60) P1 (00, 01, 02)	○	○	○	○	○	○	○	○	○		

Trouble content		Judgment block	Trouble code (23cpm/31cpm(G) machine)	Trouble code (26cpm/36cpm/31cpm(A) machine)	Operatable mode								FAST Notification to host		
					Copy scan (including interruption)	Scan (Push)	Scan (Pull)	Scan-To HDD	Print	List print	FAX Send	FAX print			
Laser trouble	• LSU breakdown	PCU	E7 (20, 28, 29) L6 (10)	E7 (20, 24, 28, 29, A0) L6 (10)	×	×	×	×	×	×	×	×	×	○	
Engine trouble 1	• Connection trouble (Model data discrepancy) (PCU detection)		A0 (21) E7 (50, 55) F1 (50)	A0 (21) E7 (50, 55) F1 (50)	×	×	×	×	×	×	×	×	×	×	×
Engine trouble 2	• PCU troubles (motor, fusing, etc.)		C1 (10, 14) C4 (00) F2 (22, 40, 64, 70, 74, 91) H2 (00, 01, 02, 03) H3 (00, 01, 02) H4 (00, 01, 02, 30) H5 (01) H7 (10, 11, 12) L4 (02, 03, 04, 05, 06, 11, 12, 16, 31, 32, 35, 43, 50, 51) L8 (01) U2 (90, 91)	C1 (10, 14) C4 (00) F2 (22, 40, 64, 70, 74, 91) H2 (00, 01, 02, 03) H3 (00, 01, 02) H4 (00, 01, 02, 30) H5 (01) H7 (10, 11, 12) L4 (02, 03, 04, 05, 06, 07, 11, 12, 16, 29, 31, 32, 34, 35, 43, 50, 51) L8 (01) U2 (90, 91)	×	×	×	×	×	×	×	×	×	○	
Process system trouble	• LSU/Process system breakdown		E7 (21, 22, 23) F2 (23, 24, 25, 41, 42, 43, 65, 66, 67, 71, 72, 73, 75, 76, 77, 92, 93, 94)	E7 (21, 22, 23, 25, 26, 27, A1, A2, A3) F2 (23, 24, 25, 41, 42, 43, 65, 66, 67, 71, 72, 73, 75, 76, 77, 92, 93, 94)	×	×	×	×	×	×	×	×	×	×	○
Paper feed tray 1 trouble	• Paper feed tray 1 breakdown		F3 (12)	F3 (12)	△3	○	○	○	△3	△3	○	△3	*10	○	
Paper feed tray 2 trouble	• Paper feed tray 2 breakdown		F3 (22)	F3 (22)	△3	○	○	○	△3	△3	○	△3	*10	○	
Paper feed tray 3 trouble	• Paper feed tray 3 breakdown		U6 (01)	U6 (01)	△3	○	○	○	△3	△3	○	△3	*10	○	
Paper feed tray 4 trouble	• Paper feed tray 4 breakdown		U6 (02)	U6 (02)	△3	○	○	○	△3	△3	○	△3	*10	○	
Paper feed tray 5 trouble	• Paper feed tray 5 breakdown		U6 (52)	U6 (03, 09, 20, 21, 22, 51, 52)	△3	○	○	○	△3	△3	○	△3	*10	○	
Paper feed tray other troubles	• Paper feed tray other breakdown		U6 (00, 10, 50)	U6 (00, 10, 50)	△11	○	○	○	△11	△11	○	△11	*10	○	
Staple trouble	• Staple breakdown	F1 (08, 10)	F1 (08, 10)	△4	△4	△4	△4	△4	△4	△4	△4	*10	○		
Saddle stitch section trouble	• Saddle stitch section breakdown		F1 (31, 41, 43, 45, 47)	△4	△4	△4	△4	△4	△4	△4	△4	*10	○		
Finisher trouble	• After-process breakdown	F1 (00, 03, 15, 19, 20, 21, 33, 34, 37)	F1 (00, 03, 11, 15, 19, 20, 21, 32, 33, 34, 36, 37, 38, 39)	△4	△4	△4	△4	△4	△4	△4	△4	*10	○		
Other troubles	• Other troubles	EE (EC, EL, EU)	EE (EC, EL, EU)	○	○	○	○	○	○	○	○	○	○		
Process control trouble	• Process control breakdown (PCU detection)	F2 (39, 49, 50, 51, 58, 78)	F2 (39, 49, 50, 51, 58, 78)	○	○	○	○	○	○	○	○	○	○		

Trouble content		Judgment block	Trouble code (23cpm/31cpm(G) machine)	Trouble code (26cpm/36cpm/31cpm(A) machine)	Operatable mode								
					Copy scan (including interruption)	Scan (Push)	Scan (Pull)	Scan-To HDD	Print	List print	FAX Send	FAX print	FAST Notification to host
Operation disable trouble	• Connection trouble (Model data discrepancy) (SCU detection)	SCU	A0 (22)	A0 (22)	×	×	×	×	×	×	×	×	×
SCU CPT ASIC trouble	• SCU CPT ASIC error		UC (02)	UC (02)	△9	△9	△9	△9	○	○	△9	○	○
SCU ASIC trouble (SCU detection)	• SCU ASIC error (SCU detection)		UC (20)	UC (20)	×	×	×	×	○	○	×	○	○
Scanner trouble 1	• SCU EEPROM error		U2 (80, 81)	U2 (80, 81)	×	×	×	×	○	○	×	○	○
Scanner trouble 2	• Scanner section breakdown (mirror motor, lens, copy lamp)		L1 (00) L3 (00)	L1 (00) L3 (00)	×	×	×	×	○	○	×	○	○
CCD trouble	• CCD breakdown (shading, etc.)		E7 (10, 11, 14)	E7 (10, 11, 14)	×	×	×	×	○	○	×	○	○

#### Error where only history data are saved

Trouble content	Judgment block	Trouble code	Operatable mode									
			Copy scan (including interruption)	Scan (Push)	Scan (Pull)	Scan-To HDD	Print	List print	FAX Send	FAX print	FAST Notification to host	
Error history	PCU	F2 (45)	○	○	○	○	○	○	○	○	○	○
Error history	MFP	E7 (02)*20 U2 (05)*20	○	○	○	○	○	○	○	○	○	○

○: Operation enabled    ×: Operation disabled

△1: The operation is enabled in a line other than the trouble line.

△3: When detected during other than a job, the operation is enabled with a tray other than the trouble tray.

△4: When detected during other than a job, the operation is enabled in a section other than the trouble paper exit section. \* However, it is valid only when the escape tray setting has been made.

△9: When detected during other than a job, the operation is enabled in the black and white mode.

\*10: Since communication is enabled, reception can be transferred.

△11: When detected during other than a job, the operation is enabled in other than the DESK and the LCC.

\*12: A trouble message is displayed. (Example: Ready to copy. F2 trouble)

△15: FAST notification function (When in U2-22, trouble notification cannot be made. If there is no abnormality in the FAX software or the FAST data in U2-23, trouble notification can be made.)

△17: Job execution enable only in a format other than high compression PDF.

\*19: When the color mode is set to disable in the "Color mode disable setting" of the system setting, the operation is enabled in the black and white mode.

\*20: 26cpm/31cpm/36cpm machine only

**(2) Trouble detection sequence and trouble cancel sequence when turning on the power**

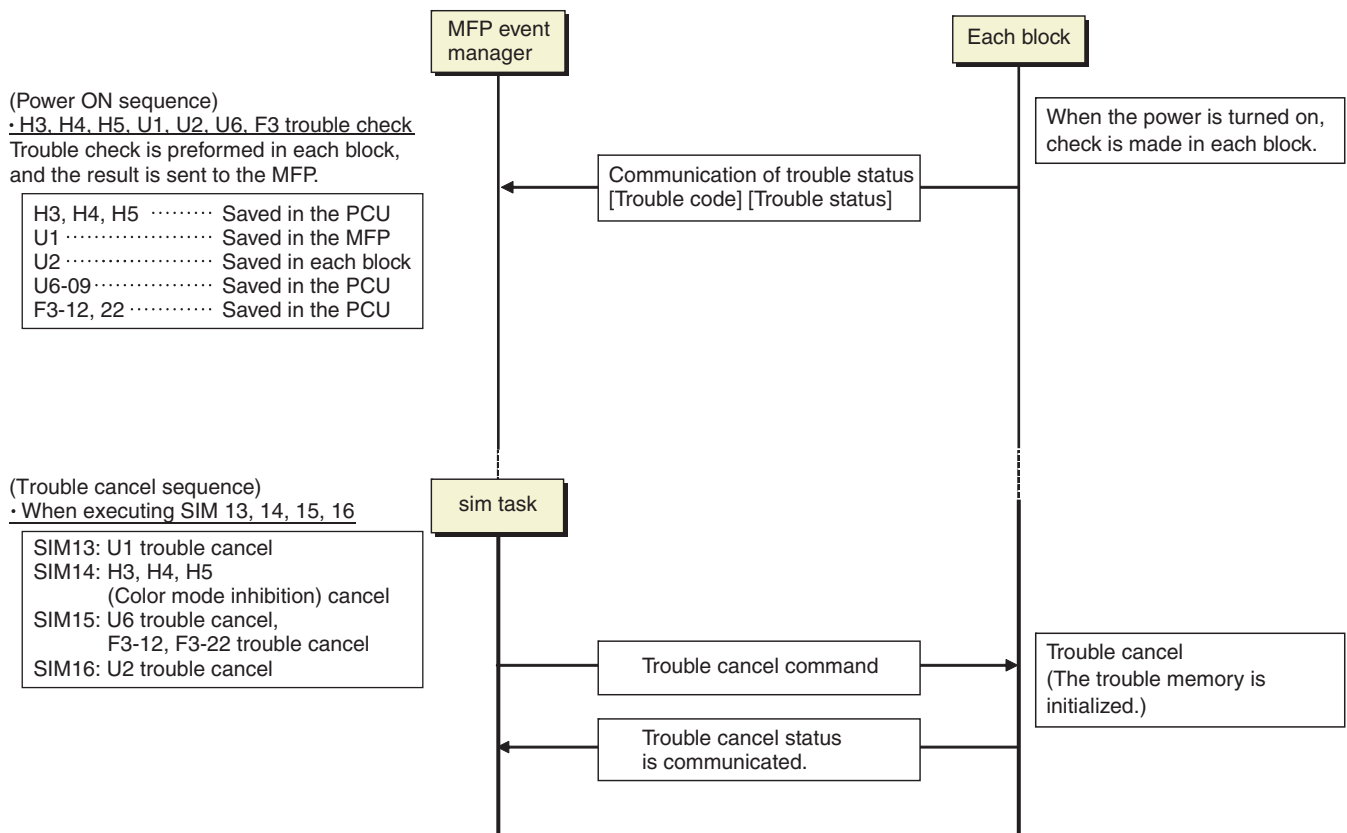

**The process has priority when the power is turned ON with the MFP.**

When booting, two or more troubles in the list below may be detected. In this case, the trouble code of higher priority is displayed.

Process sequence	Error code	Content
First (Low priority)	U2	60 Watermark check error
		50 HDD user authentication data check sum error
		30 MFPC PWB and PCU PWB manufacturing No. data inconsistency
		24 User authentication counter check sum error
		10 User authentication index check sum error
↑	A0	15 Incompatible DSK BOOT and program firmware
		20 Conflict firmware and EEPROM data version (MFP)
↓	U2	11 MFPC PWB EEPROM counter check sum error
		00 MFP EEPROM read/write error
Last (High priority)	E7	48 Scanner expansion PWB (ACRE) ASIC memory error
		42 Image data trouble (Scanner expansion PWB (ACRE) ASIC)
		96 MFPC PWB DIMM memory check error (MFPC PWB)
		95 Printer PWB DIMM memory check error (PRINTER section)
	U1	01 Battery trouble
E7	60 Combination error between PWB and firmware (MFPC PWB detection)	
A0	04 Scanner expansion PWB (ACU) (ACRE) ROM error	

## F. Error code list

Trouble code		Trouble content	Trouble detection	Mechanism	Option	Electricity	FAX	Supply
Main code	Sub code							
A0	01	PCU PWB ROM error	MFP			○		
	02	SCU PWB ROM error	MFP			○		
	04	Scanner expansion PWB (ACU) (ACRE) ROM error	MFP			○		
	05	Scanner expansion PWB (ACU) (ACRE) firmware error	MFP			○		
	10	Color profile error	MFP			○		
	11	Firmware version inconsistency (MFP - PCU)	MFP			○		
	14	Inconsistency between the MFP and the CPU firmware version	MFP			○		
	15	Incompatible DSK BOOT and program firmware	MFP			○		
	16	Data error of the energy-saving NIC controller firmware in the SD card	MFP			○		
	17	Inconsistency between the UI data and the CPU firmware version	MFP			○		
	20	Conflict firmware and EEPROM data version (MFP)	MFP			○		
	21	Conflict firmware and EEPROM data version (PCU)	PCU			○		
22	Conflict firmware and EEPROM data version (SCU)	SCU			○			
C1	10	Main charger trouble (Monochrome)	PCU			○		
	14	Main charger trouble (Color)	PCU			○		
C4	00	PTC trouble (TC high voltage trouble)	PCU			○		
E7	01	MFP image data error	MFP			○		
	02	HDD trouble when the mirroring kit is installed	MFP		○			
	03	HDD trouble / Mirroring kit error	MFP			○		
	04	HDD-ASIC error	MFP			○		
	07	SD card error	MFP			○		
	10	Shading error (Black correction)	SCU			○		
	11	Shading error (White correction)	SCU			○		
	14	CCD-ASIC error	SCU			○		
	20	LSU laser detection error (K)	PCU			○		
	21	LSU laser detection error (C)	PCU			○		
	22	LSU laser detection error (M)	PCU			○		
	23	LSU laser detection error (Y)	PCU			○		
	24	LSU LD driver error (K)	PCU			○		
	25	LSU LD driver error (C)	PCU			○		
	26	LSU LD driver error (M)	PCU			○		
	27	LSU LD driver error (Y)	PCU			○		
	28	LSU - PCU connection error	PCU			○		
	29	LSU ASIC frequency error	PCU			○		
	42	Image data trouble (Scanner expansion PWB (ACRE) ASIC)	MFP			○		
	46	Image data decode error (Scanner expansion PWB (ACRE) ASIC)	MFP			○		
	48	Scanner expansion PWB (ACRE) ASIC memory error	MFP			○		
	49	Water Mark data error	MFP			○		
	50	Combination error between PWB and firmware (PCU PWB detection)	PCU			○		
	55	PCU PWB information sum error	PCU			○		
	60	Combination error between PWB and firmware (MFPC PWB detection)	MFP			○		
	61	Combination error between the MFPC PWB and the PCU PWB (MFPC PWB detection)	MFP			○		
	65	MFP EEPROM sum check error	MFP			○		
	80	MFP - SCU PWB communication error	MFP			○		
	89	Communication error between MFPC PWB CPU and energy-saving NIC controller	MFP			○		
	90	MFP - PCU PWB communication error	MFP			○		
	91	FAX reception image data error	MFP				○	
	92	Copy image data error	MFP			○		
	93	Copy, image send, FAX, filing, print image data process error	MFP			○		
94	Image file data process error (when importing file data)	MFP			○			
95	Printer PWB DIMM memory check error	MFP			○			
96	MFPC PWB DIMM memory check error	MFP			○			
A0	LSU LD PWB EEPROM read/write error (K)	PCU			○			
A1	LSU LD PWB EEPROM read/write error (C)	PCU			○			
A2	LSU LD PWB EEPROM read/write error (M)	PCU			○			
A3	LSU LD PWB EEPROM read/write error (Y)	PCU			○			
EE	EC	Automatic toner density adjustment error	PCU			○		
	EL	Automatic toner density adjustment error (Over toner)	PCU			○		
	EU	Automatic toner density adjustment error (Under toner)	PCU			○		
F1	00	Finisher - PCU PWB communication error	PCU		○			
	03	Finisher paper exit roller lifting operation trouble	PCU		○			
	08	Stapler shift trouble	PCU		○			
	10	Staple operation trouble	PCU		○			
	11	Finisher grip motor trouble	PCU		○			
	15	Finisher paper exit tray lift operation trouble	PCU		○			

Trouble code		Trouble content	Trouble detection	Mechanism	Option	Electricity	FAX	Supply
Main code	Sub code							
F1	19	Finisher alignment operation trouble F	PCU		○			
	20	Finisher alignment operation trouble R	PCU		○			
	21	Finisher fan trouble	PCU		○			
	31	Finisher saddle motor trouble (Saddle stitch finisher)	PCU		○			
	32	Communication error between the finisher and the punch unit (Saddle stitch finisher)	PCU		○			
	33	Punch unit shift operation trouble	PCU		○			
	34	Punch operation trouble	PCU		○			
	36	Punch paper edge detection error	PCU		○			
	37	Finisher data backup RAM error	PCU		○			
	38	Punch data backup RAM error	PCU		○			
	39	Punch paper dust sensor error	PCU		○			
	41	Saddle paper positioning operation trouble	PCU		○			
	43	Saddle alignment operation trouble	PCU		○			
	45	Saddle staple trouble	PCU		○			
	47	Saddle paper transport motor trouble	PCU		○			
50	Main unit - Finisher combination error	PCU		○				
F2	22	Discharge lamp trouble (K)	PCU					○
	23	Discharge lamp trouble (C)	PCU					○
	24	Discharge lamp trouble (M)	PCU					○
	25	Discharge lamp trouble (Y)	PCU					○
	39	Process thermistor trouble	PCU					○
	40	Toner density sensor trouble (K)	PCU					○
	41	Toner density sensor trouble (C)	PCU					○
	42	Toner density sensor trouble (M)	PCU					○
	43	Toner density sensor trouble (Y)	PCU					○
	45	Color image density sensor trouble	PCU					○
	49	LSU thermistor trouble	PCU					○
	50	K drum phase sensor trouble	PCU					○
	51	CL drum phase sensor trouble	PCU					○
	58	Temperature/humidity sensor trouble (HUD_M/TH_M)	PCU					○
	64	Toner supply operation trouble (K)	PCU					○
	65	Toner supply operation trouble (C)	PCU					○
	66	Toner supply operation trouble (M)	PCU					○
	67	Toner supply operation trouble (Y)	PCU					○
	70	Improper toner cartridge detection (K)	PCU					○
	71	Improper toner cartridge detection (C)	PCU					○
	72	Improper toner cartridge detection (M)	PCU					○
	73	Improper toner cartridge detection (Y)	PCU					○
	74	Toner cartridge CRUM error (K)	PCU					○
	75	Toner cartridge CRUM error (C)	PCU					○
	76	Toner cartridge CRUM error (M)	PCU					○
	77	Toner cartridge CRUM error (Y)	PCU					○
78	Registration/BK image density sensor trouble (Transfer belt substrate reflection rate abnormality)	PCU					○	
91	High density process control high voltage error (K)	PCU					○	
92	High density process control high voltage error (C)	PCU					○	
93	High density process control high voltage error (M)	PCU					○	
94	High density process control high voltage error (Y)	PCU					○	
F3	12	Paper feed tray 1 lift operation trouble	PCU	○				
	22	Paper feed tray 2 lift operation trouble	PCU	○				
F6	00	MFPC PWB - FAX communication trouble	MFP				○	
	01	FAX control PWB EEPROM read/write error	FAX				○	
	04	FAX MODEM operation trouble	FAX				○	
	21	Improper combination of TEL/LIU PWB and FAX soft switch	MFP				○	
	30	FAX 1-chip microprocessor access error (FAX detection)	MFP				○	
	97	Incompatibility between FAX control PWB and the main machine	MFP				○	
	98	Incompatibility between the FAX control PWB destination and the main machine destination	MFP				○	
F9	91	Communication error between MFP and the printer section when booting	MFP					
	92	Printer (section) PWB hardware error	PRINTER (section) PWB			○		
H2	00	Thermistor open trouble (TH_UM_AD2)	PCU	○				
	01	Thermistor open trouble (TH_LM)	PCU	○				
	02	Thermistor open trouble (TH_US)	PCU	○				
	03	Thermistor open trouble (TH_UM_AD1)	PCU	○				

Trouble code		Trouble content	Trouble detection	Mechanism	Option	Electricity	FAX	Supply	
Main code	Sub code								
H3	00	Fusing section high temperature trouble (TH_UM)	PCU	○					
	01	Fusing section high temperature trouble (TH_LM)	PCU	○					
	02	Fusing section high temperature trouble (TH_US)	PCU	○					
H4	00	Fusing section low temperature trouble (TH_UM_AD2)	PCU	○					
	01	Fusing section low temperature trouble (TH_LM)	PCU	○					
	02	Fusing section low temperature trouble (TH_US)	PCU	○					
H5	01	5 times continuous POD1 not-reach jam	PCU	○					
H7	10	Recovery error from low fuser temp. (TH_UM_AD2)	PCU	○					
	11	Recovery error from low fuser temp. (TH_LM)	PCU	○					
L1	00	Scanner feed trouble	SCU	○					
L3	00	Scanner return trouble	SCU	○					
L4	02	Paper feed motor trouble	PCU			○			
	03	Fusing motor trouble	PCU			○			
	04	Developing motor trouble (BLACK)	PCU			○			
	05	Developing motor trouble (COLOR)	PCU			○			
	06	Transfer unit lift trouble	PCU			○			
	07	Transfer belt motor trouble	PCU			○			
	11	Shift motor trouble	PCU			○			
	12	Secondary transfer separation trouble	PCU	○					
	16	Fusing pressure release trouble	PCU			○			
	31	Paper exit cooling fan trouble	PCU			○			
	32	Power source cooling fan trouble	PCU			○			
	34	LSU cooling fan trouble	PCU			○			
	35	Fusing cooling fan trouble	PCU			○			
	43	Paper exit cooling fan 2 trouble	PCU			○			
	L6	50	Process fan trouble	PCU			○		
51		Process fan 2 trouble	PCU			○			
L8	10	Polygon motor trouble	PCU			○			
	01	Full wave signal detection error	PCU			○			
P1	20	Communication error of MFPC PWB/LSU mother board	MFP			○			
	00	PCI communication error	MFP		○				
	01	PCI fan error	MFP		○				
PC	02	Plasma generating device error	MFP		○				
	-	Personal counter not detected	MFP	○					
U1	01	Battery trouble	MFP			○			
U2	00	MFP EEPROM read/write error	MFP			○			
	05	HDD/MFPC PWB SRAM contents inconsistency (18cpm/20cpm/23cpm/31cpm(G) machine)	MFP			○			
	05	Erroneous detection of account management data / HDD internal authentication DB table error (26cpm/36cpm/31cpm(A) machine)	MFP			○			
	10	MFPC PWB SRAM user authentication index check sum error	MFP			○			
	11	MFPC PWB EEPROM counter check sum error	MFP			○			
	24	MFPC PWB SRAM memory user authentication counter check sum error	MFP			○			
	30	MFPC PWB and PCU PWB manufacturing No. data inconsistency	MFP			○			
	40	SD card system storage data area error	MFP			○			
	41	HDD system storage data area error	MFP			○			
	42	Machine adjustment data (system storage data area) error	MFP			○			
	50	HDD user authentication data check sum error	MFP			○			
	60	Watermark check error	MFP			○			
	80	SCU PWB EEPROM read/write error	SCU			○			
	81	SCU PWB EEPROM check sum error	SCU			○			
	U6	90	PCU PWB EEPROM read/write error	PCU			○		
91		PCU PWB EEPROM check sum error	PCU			○			
00		PCU PWB - Paper feed desk (paper feed tray 3, 4) communication trouble	PCU			○			
01		Desk paper feed tray 1 lift trouble	PCU		○				
02		Desk paper feed tray 2 lift trouble	PCU		○				
09		LCC lift motor trouble	PCU		○				
10		Desk paper feed unit paper transport motor trouble	PCU		○				
20		LCC control PWB - PCU PWB communication error	PCU		○				
21		LCC transport motor trouble	PCU		○				
22		LCC 24V power trouble	PCU		○				
50		Desk - Main unit combination trouble	PCU		○				
51		LCC - Main unit combination trouble	PCU		○				
52		PCU PWB - Paper feed desk (paper feed tray 2) communication trouble	PCU			○			
U7		50	MFPC PWB - Vendor machine communication error	MFP			○		
		51	Vendor machine error	MFP			○		
UC	02	CPT - ASIC error	SCU			○			
	20	DOCC ASIC error	SCU			○			



## G. Details of error codes and countermeasures

### A0-01 PCU PWB ROM error

Trouble content	
Detail	MFP
Cause	The firmware version-up is not completed properly by interruption of the power during the version-up operation, etc. PCU PWB trouble.
Check & Remedy	Use SIM49-1 to perform the firmware version-up procedure again. Replace the PCU PWB.

### A0-02 SCU PWB ROM error

Trouble content	
Detail	MFP
Cause	The firmware version-up is not completed properly by interruption of the power during the version-up operation, etc. SCU PWB trouble.
Check & Remedy	Use SIM49-1 to perform the firmware version-up procedure again. Replace the SCU PWB.

### A0-04 Scanner expansion PWB (ACU) (ACRE) ROM error

Trouble content	
Detail	MFP
Cause	Scanner expansion PWB (ACU) (ACRE) ROM data error. An error occurs during firmware upgrading for some reasons.
Check & Remedy	Perform firmware upgrading again.

### A0-05 Scanner expansion PWB (ACU) (ACRE) firmware error

Trouble content	
Detail	MFP
Cause	Improper firmware A firmware of a different model is installed. A ROM of a different model is installed.
Check & Remedy	Replace the ROM with a proper one. Write the proper firmware. (Upgrade to the proper firmware.)

### A0-10 Color profile error

Trouble content	Color profile error
Detail	MFP
Cause	The content of the color profile is abnormal. Combination error between the MFPC PWB firmware and the color profile
Check & Remedy	Upgrade the firmware collectively. Replace the MFPC PWB.

### A0-11 Firmware version inconsistency (MFP - PCU)

Trouble content	
Detail	MFP
Cause	Firmware combination error between the MFP and the PCU.
Check & Remedy	Install the firmware in the all-firmware version-up mode.

### A0-14 Inconsistency between the MFP and the CPU firmware version

Trouble content	
Detail	MFP
Cause	Combination error between the MFP and the CPU UI firmware version.
Check & Remedy	Install the firmware in the all-firmware version-up mode.

### A0-15 Incompatible DSK BOOT and program firmware

Trouble content	
Detail	MFP
Cause	Installation of the normal firmware was performed with a security kit enable.
Check & Remedy	Stop installation of the normal firmware.

### A0-16 Data error of the energy-saving NIC controller firmware in the SD card

Trouble content	Data error of the energy-saving NIC controller firmware in the SD card.
Detail	MFP
Cause	SD card trouble. MFPC PWB trouble.
Check & Remedy	Reinstall the firmware. Replace the SD card. Replace the MFPC PWB.

### A0-17 Inconsistency between the UI data and the CPU firmware version

Trouble content	
Detail	MFP
Cause	Combination error between the UI contents data and the CPU UI firmware version.
Check & Remedy	Install the firmware in the all-firmware version-up mode.

### A0-20 Conflict firmware and EEPROM data version (MFP)

Trouble content	
Detail	MFP
Cause	Inconsistency between the MFP firmware version and the EEPROM data version.
Check & Remedy	Check the combination of the firmware.

### A0-21 Conflict firmware and EEPROM data version (PCU)

Trouble content	
Detail	PCU
Cause	Inconsistency between the PCU firmware version and the EEPROM data version.
Check & Remedy	Check the combination of the firmware.

### A0-22 Conflict firmware and EEPROM data version (SCU)

Trouble content	
Detail	SCU
Cause	Inconsistency between the SCU firmware version and the EEPROM data version.
Check & Remedy	Check the combination of the firmware.

### C1-10 Main charger trouble (Monochrome)

Trouble content	
Detail	PCU
Cause	The main charger unit (BK) is not installed properly. There is an abnormality in the main charger unit (BK). The developer unit (KCMY) is not installed properly. There is an abnormality in the developer unit (KCMY). Disconnection of the high voltage MC PWB connector. Breakage of the high voltage harness. High voltage MC PWB trouble. PCU PWB trouble.
Check & Remedy	Check the output of the main charger with SIM8-2. Check the output of the developing bias with SIM8-1. Check disconnection of the main charger./Replace. Check disconnection of the developer unit./Replace. Check disconnection of the high voltage MC PWB connector./Replace. Replace the high voltage MC PWB. Replace the PCU PWB.

### C1-14 Main charger trouble (Color)

Trouble content	
Detail	PCU
Cause	The main charger unit (CMY) is not installed properly. There is an abnormality in the main charger unit (CMY). Disconnection of the high voltage MC PWB connector. Breakage of the high voltage harness. High voltage MC PWB trouble. PCU PWB trouble.
Check & Remedy	Check the output of the main charger with SIM8-2. Check disconnection of the main charger./Replace. Check disconnection of the high voltage MC PWB connector./Replace. Replace the high voltage MC PWB Replace the PCU PWB.

### C4-00 PTC trouble (TC high voltage trouble)

Trouble content	
Detail	PCU
Cause	The PTC unit is not installed properly./Trouble. The primary transfer unit is not installed properly./ Trouble. The secondary transfer unit is not installed properly./ Trouble. High voltage TC PWB trouble. PCU PWB trouble. Connection trouble of the connector and the harness.
Check & Remedy	Replace the PTC unit. Replace the primary transfer unit. Replace the secondary transfer unit. Check disconnection of the high voltage TC PWB connector./Replace. Replace the high voltage TC PWB. Replace the PCU PWB.

### E7-01 MFP image data error

Trouble content	
Detail	MFP
Cause	Image data transfer error in the MFPC PWB. MFPC PWB trouble.
Check & Remedy	Check connection of the connector and the harness of the MFPC PWB. Check or replace the MFPC PWB.

### E7-02 HDD trouble when the mirroring kit is installed

Trouble content	
Detail	MFP
Cause	When installing the mirroring kit, the HDD of the machine or the HDD of the mirroring kit breaks down or connection fails. <ul style="list-style-type: none"> <li>• Defective installation of the mirroring kit</li> <li>• Breakdown of the HDD of the mirroring kit</li> <li>• Breakdown of the HDD of</li> <li>• Defective connection between the HDD and the mirroring kit harness</li> <li>• MFP PWB trouble</li> </ul>
Check & Remedy	<ul style="list-style-type: none"> <li>• Use SIM62-20 to check the trouble.</li> <li>• Check installation of the mirroring kit (connector and harness), and replace if necessary.</li> <li>• Replace the broken HDD.</li> <li>• Replace the mirroring kit.</li> <li>• Replace the MFP PWB.</li> </ul>

**E7-03 HDD trouble / Mirroring kit error**

Trouble content	
Detail	MFP
Cause	Connector, harness connection trouble in the MFPC PWB and HDD. HDD (error file management area) data abnormality (FAT breakage). MFPC PWB trouble.  (When the mirroring kit is installed) RAID PWB trouble. A HDD which has been used for mirroring is installed. Both HDD's go into trouble under the use environment of mirroring.
Check & Remedy	Check connection of the connector and the harness of the MFPC PWB and HDD. Use SIM62-2, 3 to check read/write operations of the HDD. Replace the HDD. Check or replace the MFPC PWB.  (When the mirroring kit is installed) Check the RAID PWB, and replace if necessary. Replace the HDD. (For details, refer to the HDD and RAID PWB replacement procedures under mirroring environment.)

**E7-04 HDD-ASIC error**

Trouble content	
Detail	MFP
Cause	HDD-ASIC trouble. (MFPC PWB trouble.) An error occurs in the HDD-ASIC self test when booting.
Check & Remedy	Check or replace the MFPC PWB.

**E7-07 SD card error**

Trouble content	
Detail	MFP
Cause	SD card trouble or contact error MFPC PWB trouble.
Check & Remedy	Replace the SD card. Check the SD card socket. Replace the MFPC PWB.

**E7-10 Shading error (Black correction)**

Trouble content	
Detail	SCU
Cause	Abnormality in the CCD black scan level when the scanner lamp is turned OFF. Improper installation of the harness to the CCD unit. CCD unit abnormality. SCU PWB abnormality.
Check & Remedy	Check connection of the harness to the CCD unit. Check the CCD unit. Check the SCU PWB.

**E7-11 Shading error (White correction)**

Trouble content	
Detail	SCU
Cause	Abnormality in the CCD white reference plate scan level when the scanner lamp is turned ON. Improper installation of the harness to the CCD unit. Dirt on the mirror, lens, and the reference white plate. Scanner lamp lighting trouble. Scanner lamp drive PWB trouble CCD unit abnormality. SCU PWB abnormality.
Check & Remedy	Check connection of the harness to the CCD unit. Check connection of the harness to the scanner lamp unit. Check or replace the scanner lamp. Check or replace the scanner lamp drive PWB. Clean or replace the mirror, the lens, and the reference white board. Check or replace the CCD unit. Check or replace the SCU PWB.

**E7-14 CCD-ASIC error**

Trouble content	
Detail	SCU
Cause	SCU PWB trouble.
Check & Remedy	Check the SCU PWB. Replace the SCU PWB.

**E7-20 LSU laser detection error (K)**

Trouble content	
Detail	PCU
Cause	Laser optical axis misalignment Reduced laser power, lighting error, laser diode trouble. LSU harness, connector trouble LSU trouble
Check & Remedy	Use SIM61-1 to check the operation of the LSU. Check or replace the LSU control PWB. Check connection of the LSU harness. Replace the LSU.

**E7-21 LSU laser detection error (C)**

Trouble content	
Detail	PCU
Cause	Laser optical axis misalignment Reduced laser power, lighting error, laser diode trouble. LSU harness, connector trouble LSU trouble
Check & Remedy	Use SIM61-1 to check the operation of the LSU. Check or replace the LSU control PWB. Check connection of the LSU harness. Replace the LSU.

**E7-22 LSU laser detection error (M)**

Trouble content	
Detail	PCU
Cause	Laser optical axis misalignment Reduced laser power, lighting error, laser diode trouble. LSU harness, connector trouble LSU trouble
Check & Remedy	Use SIM61-1 to check the operation of the LSU. Check or replace the LSU control PWB. Check connection of the LSU harness. Replace the LSU.

**E7-23 LSU laser detection error (Y)**

Trouble content	
Detail	PCU
Cause	Laser optical axis misalignment Reduced laser power, lighting error, laser diode trouble. LSU harness, connector trouble LSU trouble
Check & Remedy	Use SIM61-1 to check the operation of the LSU. Check or replace the LSU control PWB. Check connection of the LSU harness. Replace the LSU.

**E7-24 LSU LD driver error (K)**

Trouble content	
Detail	PCU
Cause	When lighting the LSU LD, initialization of the LD driver is not performed normally. Harness/connector trouble between the LD PWB and the LSU mother PWB. LD PWB trouble. LSU mother PWB trouble.
Check & Remedy	Use SIM61-1 to check the operation of the LSU. Check the LSU, and replace if necessary. Check the LSU mother PWB, and replace if necessary. Check connection of the harness/connector between the LD PWB and the LSU mother PWB.

**E7-25 LSU LD driver error (C)**

Trouble content	
Detail	PCU
Cause	When lighting the LSU LD, initialization of the LD driver is not performed normally. Harness/connector trouble between the LD PWB and the LSU mother PWB. LD PWB trouble. LSU mother PWB trouble.
Check & Remedy	Use SIM61-1 to check the operation of the LSU. Check the LSU, and replace if necessary. Check the LSU mother PWB, and replace if necessary. Check connection of the harness/connector between the LD PWB and the LSU mother PWB.

**E7-26 LSU LD driver error (M)**

Trouble content	
Detail	PCU
Cause	When lighting the LSU LD, initialization of the LD driver is not performed normally. Harness/connector trouble between the LD PWB and the LSU mother PWB. LD PWB trouble. LSU mother PWB trouble.
Check & Remedy	Use SIM61-1 to check the operation of the LSU. Check the LSU, and replace if necessary. Check the LSU mother PWB, and replace if necessary. Check connection of the harness/connector between the LD PWB and the LSU mother PWB.

**E7-27 LSU LD driver error (Y)**

Trouble content	
Detail	PCU
Cause	When lighting the LSU LD, initialization of the LD driver is not performed normally. Harness/connector trouble between the LD PWB and the LSU mother PWB. LD PWB trouble. LSU mother PWB trouble.
Check & Remedy	Use SIM61-1 to check the operation of the LSU. Check the LSU, and replace if necessary. Check the LSU mother PWB, and replace if necessary. Check connection of the harness/connector between the LD PWB and the LSU mother PWB.

**E7-28 LSU - PCU connection error**

Trouble content	
Detail	PCU
Cause	Communication error between the CPU in the PCU PWB and the LSU control ASIC. Improper connection of the communication connector between the PCU PWB and the LSU control PWB (interface PWB). Harness trouble between the PCU PWB and the LSU control PWB (interface PWB) PCU PWB trouble. LSU control PWB trouble. LSU trouble. LSU mother PWB trouble.
Check & Remedy	Check connection of the connector and the harness between the PCU PWB and the LSU control PWB (interface PWB). Replace the LSU mother PWB. Replace the PCU PWB. Replace the LSU. Replace the LSU control PWB.

**E7-29 LSU ASIC frequency error**

Trouble content	
Detail	PCU
Cause	Oscillation abnormality of the external oscillator and the internal oscillating circuit used in the LSU ASIC. LSU ASIC abnormality on the LSU ASIC PWB.
Check & Remedy	Replace the LSU control PWB.

**E7-42 Image data trouble (Scanner expansion PWB (ACRE) ASIC)**

Trouble content	
Detail	MFP
Cause	An image data error occurs. An image data send error occurs. Scanner expansion PWB (ACRE) connection trouble. Scanner expansion PWB (ACRE) trouble. MFPC PWB trouble.
Check & Remedy	Check connection of the scanner expansion PWB (ACRE). Check the scanner expansion PWB (ACRE), and replace if necessary. Check the MFPC PWB, and replace if necessary.

**E7-46 Image data decode error (Scanner expansion PWB (ACRE) ASIC)**

Trouble content	
Detail	MFP
Cause	A decode error occurs while high compression PDF images are made. (garbled data) Scanner expansion PWB (ACRE) connection trouble. Scanner expansion PWB (ACRE) trouble. MFPC PWB trouble.
Check & Remedy	Check connection of the scanner expansion PWB (ACRE). Check the scanner expansion PWB (ACRE), and replace if necessary. Check the MFPC PWB, and replace if necessary.

**E7-48 Scanner expansion PWB (ACRE) ASIC memory error**

Trouble content	<ul style="list-style-type: none"> <li>• DDR calibration error</li> <li>• DIMM insertion trouble, etc.</li> </ul>
Detail	MFP
Cause	Scanner expansion PWB (ACRE) DIMM trouble, memory slot trouble. Scanner expansion PWB (ACRE) DIMM insertion trouble. Scanner expansion PWB (ACRE) connection trouble. Scanner expansion PWB (ACRE) trouble. MFPC PWB trouble.
Check & Remedy	Check insertion of the scanner expansion PWB (ACRE) DIMM memory. Check the scanner expansion PWB (ACRE) DIMM memory, and replace if necessary. Check connection of the scanner expansion PWB (ACRE). Check the scanner expansion PWB (ACRE), and replace if necessary. Check the MFPC PWB, and replace if necessary.

**E7-49 Water Mark data error**

Trouble content	
Detail	MFP
Cause	Watermark data trouble. HDD trouble.
Check & Remedy	Use SIM49-5 to upload the watermark data. Replace the HDD.

**E7-50 Combination error between PWB and firmware (PCU PWB detection)**

Trouble content	
Detail	PCU
Cause	A PWB/firmware/LSU which is not compatible with the machine specifications is detected. PCU PWB trouble LSU trouble
Check & Remedy	Check the kind and the version of the firmware. Check or replace the LSU. Check or replace the PCU PWB.

**E7-55 PCU PWB information sum error**

Trouble content	PCU EEPROM PWB information sum error
Detail	PCU
Cause	PCU EEPROM sum check error. PCU EEPROM trouble. PCU EEPROM contact trouble.
Check & Remedy	Replace the PCU PWB. Replace the PCU EEPROM.

**E7-60 Combination error between PWB and firmware (MFPC PWB detection)**

Trouble content	
Detail	MFP
Cause	A PWB/firmware which is not compatible with the machine specifications is detected in the MFPC PWB. MFPC PWB trouble.
Check & Remedy	Check the kind and the version of the firmware. Check or replace the MFPC PWB.

**E7-61 Combination error between the MFPC PWB and the PCU PWB (MFPC PWB detection)**

Trouble content	
Detail	MFP
Cause	Combination error between the MFPC PWB and the PCU PWB. MFPC PWB trouble. PCU PWB trouble.
Check & Remedy	Check the combination between the MFPC PWB and the PCU PWB. Replace the MFPC PWB. Replace the PCU PWB.

**E7-65 MFP EEPROM sum check error**

Trouble content	
Detail	MFP
Cause	MFPC PWB EEPROM trouble. MFPC PWB EEPROM contact trouble.
Check & Remedy	Replace the MFPC PWB. Replace the MFPC PWB EEPROM.

**E7-80 MFP - SCU PWB communication error**

Trouble content	
Detail	MFP
Cause	SCU PWB - MFPC PWB connection trouble. SCU PWB trouble. MFPC PWB trouble.
Check & Remedy	Check connection of the SCU PWB and the MFPC PWB. Check the ground. Replace the SCU PWB. Replace the MFPC PWB.

**E7-89 Communication error between MFPC PWB CPU and energy-saving NIC controller**

Trouble content	No response can be obtained from the energy-saving NIC controller.
Detail	MFP
Cause	MFPC PWB trouble.
Check & Remedy	Replace the MFPC PWB.

**E7-90 MFP - PCU PWB communication error**

Trouble content	
Detail	MFP
Cause	PCU PWB - MFPC PWB connection trouble. PCU PWB trouble. MFPC PWB trouble.
Check & Remedy	Check connection of the PCU PWB and the MFPC PWB. Check the ground. Replace the PCU PWB. Replace the MFPC PWB.

**E7-91 FAX reception image data error**

Trouble content	An error of FAX reception image data process occurs.
Detail	MFP
Cause	Image data process abnormality HDD trouble SD card trouble or contact error Image compression data corruption MFPC PWB trouble DIMM memory trouble or contact error FAX control PWB trouble
Check & Remedy	Use SIM60-01 to check the read/write operations of the memory. Replace the HDD. Replace or check installation of the SD card. Replace the MFPC PWB. Replace or check installation of the DIMM memory. Replace the FAX control PWB.

**E7-92 Copy image data error**

Trouble content	An error of copy image data process occurs. (In Non ERDH)
Detail	MFP
Cause	Image data process abnormality HDD trouble Image compression data corruption MFPC PWB trouble DIMM memory trouble or contact error
Check & Remedy	Use SIM60-01 to check the read/write operations of the memory. Replace the HDD. Replace the MFPC PWB. Replace or check installation of the DIMM memory.

**E7-93 Copy, image send, FAX, filing, print image data process error**

Trouble content	An image data process error occurs in the following operation mode: • Copy (in ERDH) • Copy composing system function (Water mark) • When in image send • When filing documents • When displaying the preview • When printing with the GDI/PCL printer • Copy composing system function (Water mark)
Detail	MFP
Cause	Image data process abnormality HDD trouble Image compression data corruption MFPC PWB trouble DIMM memory trouble or contact error
Check & Remedy	Use SIM60-01 to check the read/write operations of the memory. Replace the HDD. Replace the MFPC PWB. Replace or check installation of the DIMM memory.

**E7-94 Image file data process error (when importing file data)**

Trouble content	File image process error (backup restore error) when importing filing data
Detail	MFP
Cause	Image data process abnormality HDD trouble Image compression data corruption MFPC PWB trouble DIMM memory trouble or contact error
Check & Remedy	Use SIM60-01 to check the read/write operations of the memory. Replace the HDD. Replace the MFPC PWB. Replace or check installation of the DIMM memory.

**E7-95 Printer PWB DIMM memory check error**

Trouble content	Printer PWB DIMM memory access trouble
Detail	MFP
Cause	Memory data corruption occurs Printer PWB trouble DIMM memory trouble or contact error
Check & Remedy	Use SIM60-01 to check the read/write operations of the memory. Replace the printer PWB. DIMM memory socket check Replace the DIMM memory.

**E7-96 MFPC PWB DIMM memory check error**

Trouble content	MFPC PWB DIMM memory access trouble
Detail	MFP
Cause	Memory data corruption occurs MFPC PWB trouble DIMM memory trouble or contact error
Check & Remedy	Use SIM60-01 to check the read/write operations of the memory. Replace the MFPC PWB. DIMM memory socket check Replace the DIMM memory.

**E7-A0 LSU LD PWB EEPROM read/write error (K)**

Trouble content	Write error in the EEPROM write sequence
Detail	PCU
Cause	LD PWB EEPROM trouble. LSU mother PWB trouble. Connector/harness trouble between the LD PWB and the LSU mother PWB. Connector/harness trouble between the PCU PWB and the LSU mother PWB.
Check & Remedy	Check the LSU, and replace if necessary. Check the LSU mother PWB, and replace if necessary. Check the connector/harness between the LD PWB and the LSU mother PWB, and replace if necessary. Check the connector/harness between the PCU PWB and the LSU mother PWB, and replace if necessary. Replace the LSU.

**E7-A1 LSU LD PWB EEPROM read/write error (C)**

Trouble content	Write error in the EEPROM write sequence
Detail	PCU
Cause	LD PWB EEPROM trouble. LSU mother PWB trouble. Connector/harness trouble between the LD PWB and the LSU mother PWB. Connector/harness trouble between the PCU PWB and the LSU mother PWB.
Check & Remedy	Check the LSU, and replace if necessary. Check the LSU mother PWB, and replace if necessary. Check the connector/harness between the LD PWB and the LSU mother PWB, and replace if necessary. Check the connector/harness between the PCU PWB and the LSU mother PWB, and replace if necessary. Replace the LSU.

**E7-A2 LSU LD PWB EEPROM read/write error (M)**

Trouble content	Write error in the EEPROM write sequence
Detail	PCU
Cause	LD PWB EEPROM trouble. LSU mother PWB trouble. Connector/harness trouble between the LD PWB and the LSU mother PWB. Connector/harness trouble between the PCU PWB and the LSU mother PWB.
Check & Remedy	Check the LSU, and replace if necessary. Check the LSU mother PWB, and replace if necessary. Check the connector/harness between the LD PWB and the LSU mother PWB, and replace if necessary. Check the connector/harness between the PCU PWB and the LSU mother PWB, and replace if necessary. Replace the LSU.

**E7-A3 LSU LD PWB EEPROM read/write error (Y)**

Trouble content	Write error in the EEPROM write sequence
Detail	PCU
Cause	LD PWB EEPROM trouble. LSU mother PWB trouble. Connector/harness trouble between the LD PWB and the LSU mother PWB. Connector/harness trouble between the PCU PWB and the LSU mother PWB.
Check & Remedy	Check the LSU, and replace if necessary. Check the LSU mother PWB, and replace if necessary. Check the connector/harness between the LD PWB and the LSU mother PWB, and replace if necessary. Check the connector/harness between the PCU PWB and the LSU mother PWB, and replace if necessary. Replace the LSU.

**EE-EC Automatic toner density adjustment error**

Trouble content	The sampling level in the automatic toner density adjustment is outside of $128 \pm 10$ .
Detail	PCU
Cause	Toner density sensor trouble. Developing unit trouble. PCU PWB trouble.
Check & Remedy	Replace the toner density sensor. Replace the developing unit. Replace the PCU PWB.

**EE-EL Automatic toner density adjustment error (Over toner)**

Trouble content	The sampling level in the automatic toner density adjustment is 76 or less or the control voltage is 208 or above.
Detail	PCU
Cause	Toner density sensor trouble. Developing unit trouble. PCU PWB trouble.
Check & Remedy	Replace the toner density sensor. Replace the developing unit. Replace the PCU PWB.

## EE-EU Automatic toner density adjustment error (Under toner)

Trouble content	The sampling level in the automatic toner density adjustment is 178 or above or the control voltage is 51 or less.
Detail	PCU
Cause	Toner density sensor trouble. Developing unit trouble. PCU PWB trouble.
Check & Remedy	Replace the toner density sensor. Replace the developing unit. Replace the PCU PWB.

## F1-00 Finisher - PCU PWB communication error

Trouble content	
Detail	PCU
Cause	Connection trouble of the connector and the harness between the finisher and the PCU PWB. Finisher control PWB trouble. PCU PWB trouble.
Check & Remedy	Check the connector and the harness between the finisher and the PCU PWB. Replace the finisher control PWB. Replace the PCU PWB.

## F1-03 Finisher paper exit roller lifting operation trouble

Trouble content	
Detail	PCU
Cause	Finisher paper exit roller lift motor trouble Harness and connector connection trouble Home position sensor trouble Finisher control PWB trouble
Check & Remedy	Use SIM3-3 to check the operation of the paper exit roller lift motor. Use SIM3-2 to check the operation of the home position sensor. Replace the paper exit roller lift motor. Check connection of the connector and the harness. Replace the home position sensor. Replace the finisher control PWB.

## F1-08 Stapler shift trouble

Trouble content	
Detail	PCU
Cause	Stapler shift motor trouble. Finisher control PWB trouble. Home position sensor trouble.
Check & Remedy	Use SIM3-3 to check the operation of the stapler shift motor. Use SIM3-2 to check the operation of the home position sensor. Replace the stapler shift motor. Check connection of the connector and the harness. Replace the home position sensor. Replace the finisher control PWB.

## F1-10 Staple operation trouble

Trouble content	
Detail	PCU
Cause	Staple motor trouble. Finisher control PWB trouble. Home position sensor trouble.
Check & Remedy	Use SIM3-3 to check the operation of the staple motor. Use SIM3-2 to check the operation of the home position sensor. Replace the staple motor. Check connection of the connector and the harness. Replace the home position sensor. Replace the finisher control PWB.

## F1-11 Finisher gripper motor trouble

Trouble content	
Detail	PCU
Cause	Paper exit operation trouble caused by the gripper. Gripper motor lock or trouble. Gripper home position sensor trouble. Finisher control PWB trouble. Connection trouble of the harness and the connector of the finisher control PWB and the gripper motor.
Check & Remedy	Use SIM3-3 to check the operation of the gripper motor. Check the connection of the harness and the connector of the finisher control PWB and the gripper motor, and replace if necessary. Check the gripper motor, and replace if necessary. Check the gripper home position sensor, and replace if necessary. Check the finisher control PWB, and replace if necessary.

## F1-15 Finisher paper exit tray lift operation trouble

Trouble content	Lift motor trouble.
Detail	PCU
Cause	Paper exit tray lift motor trouble. Finisher control PWB trouble. Home position sensor trouble.
Check & Remedy	Use SIM3-3 to check the operation of the paper exit tray lift motor. Use SIM3-2 to check the operation of the home position sensor. Replace the finisher control PWB. Replace the paper exit tray lift motor. Replace the home position sensor.

## F1-19 Finisher alignment operation trouble F

Trouble content	
Detail	PCU
Cause	Finisher paper alignment motor lock. Motor speed abnormality. Over-current to the motor. Finisher control PWB trouble. Home position sensor trouble.
Check & Remedy	Use SIM3-3 to check the operation of the paper alignment motor F. Use SIM3-2 to check the operation of the home position sensor. Replace the finisher control PWB. Replace the paper alignment motor F. Replace the home position sensor.



### F1-20 Finisher alignment operation trouble R

Trouble content	
Detail	PCU
Cause	Finisher paper alignment motor lock. Motor speed abnormality. Over-current to the motor. Finisher control PWB trouble. Home position sensor trouble.
Check & Remedy	Use SIM3-3 to check the operation of the paper alignment motor R. Use SIM3-2 to check the operation of the home position sensor. Replace the finisher control PWB. Replace the paper alignment motor R. Replace the home position sensor.

### F1-21 Finisher fan trouble

Trouble content	
Detail	PCU
Cause	Motor lock, motor harness short-circuit/open, finisher control PWB trouble, connection harness/connector trouble. Fan motor lock, short-circuit, open circuit. Finisher fan trouble. Finisher control PWB trouble. Connector/harness trouble
Check & Remedy	Use SIM3-3 to check the operation of the fan. Check the finisher fan, and replace if necessary. Check the finisher control PWB, and replace if necessary. Check the connector/harness, and replace if necessary.

### F1-31 Finisher saddle motor trouble (Saddle stitch finisher)

Trouble content	
Detail	PCU
Cause	Saddle paper folding motor trouble. Saddle paper folding mechanism trouble. Finisher control PWB trouble. Folding plate home position sensor trouble. Saddle paper folding motor rotation sensor trouble. Harness/connector connection trouble. PCU PWB trouble.
Check & Remedy	Use SIM3-3 to check the operation of the saddle motor. Check the saddle paper folding mechanism. Check the finisher control PWB, and replace if necessary. Check the folding plate home position sensor, and replace if necessary. Check the saddle paper folding motor rotation sensor, and replace if necessary. Check connection of the harness/connector, and replace if necessary. Check the PCU PWB, and replace if necessary.

### F1-32 Communication error between the finisher and the punch unit (Saddle stitch finisher)

Trouble content	
Detail	PCU
Cause	Connector/harness trouble between the finisher and the punch unit. Finisher control PWB trouble. PCU PWB trouble. Malfunction due to noises.
Check & Remedy	Check the connector/harness between the finisher and the punch unit, and replace if necessary. Check the finisher control PWB, and replace if necessary. Check the PCU PWB, and replace if necessary.

### F1-33 Punch unit shift operation trouble

Trouble content	
Detail	PCU
Cause	Punch shift motor trouble. Finisher control PWB trouble. Home position sensor trouble. Harness and connector connection trouble.
Check & Remedy	Use SIM3-3 to check the operation of the punch shifting. Use SIM3-2 to check the operation of the home position sensor. Replace the punch shift motor. Replace the finisher control PWB. Replace the home position sensor. Check connection of the connectors and the harness.

### F1-34 Punch operation trouble

Trouble content	
Detail	PCU
Cause	Punch motor trouble. Finisher control PWB trouble. Home position sensor trouble. Harness and connector connection trouble.
Check & Remedy	Use SIM3-2 to check the operation of the home position sensor. Use SIM3-3 to check the operation of the punch. Replace the punch motor. Replace the finisher control PWB. Replace the home position sensor. Check connection of the connectors and the harness.

### F1-36 Punch paper edge detection error

Trouble content	
Detail	PCU
Cause	Punch paper edge sensor trouble. Harness disconnection. Finisher control PWB trouble. Punch control PWB trouble.
Check & Remedy	Use SIM3-2 to check the operation of the sensor. Replace the punch paper edge sensor. Replace the finisher control PWB. Replace the punch control PWB.

**F1-37 Finisher data backup RAM error**

Trouble content	
Detail	PCU
Cause	Finisher control PWB trouble. Malfunction due to noises
Check & Remedy	Replace the finisher control PWB. Readjust the finisher. (Use SIM3-10, Finisher control PWB DIP SW adjustment.)

**F1-38 Punch data backup RAM error**

Trouble content	
Detail	PCU
Cause	Punch control PWB trouble. Malfunction due to noises
Check & Remedy	Replace the punch control PWB. Set the punch unit specifications, and adjust the sensor. (Punch unit control PWB DIP SW adjustment.)

**F1-39 Punch paper dust sensor error**

Trouble content	
Detail	PCU
Cause	Punch dust sensor trouble. Harness and connector connection trouble. Finisher control PWB trouble. Punch unit control PWB trouble.
Check & Remedy	Use SIM3-2 to check the operation of the sensor. Check connection of the connectors and the harness. Replace the punch dust sensor. Replace the finisher control PWB. Replace the punch unit control PWB.

**F1-41 Saddle paper positioning operation trouble**

Trouble content	Abnormality in the folding positioning guide motor in the saddle section.
Detail	PCU
Cause	Saddle paper positioning guide drive motor trouble. Finisher control PWB trouble. Home position sensor trouble. Harness and connector connection trouble.
Check & Remedy	Use SIM3-3 to check the operation of the saddle paper positioning motor. Check connection from the control PWB to the motor. Turn OFF/ON the power. Replace the control PWB. Replace the sensor.

**F1-43 Saddle alignment operation trouble**

Trouble content	
Detail	PCU
Cause	Saddle alignment motor trouble. Finisher control PWB trouble. Home position sensor trouble. Harness and connector connection trouble.
Check & Remedy	Use SIM3-3 to check the operation of the Saddle alignment motor (FSPAM). Check connection from the control PWB to the motor. Turn OFF/ON the power. Replace the control PWB. Replace the sensor.

**F1-45 Saddle staple trouble**

Trouble content	Abnormality of the staple unit drive motor in the saddle section.
Detail	PCU
Cause	Saddle staple motor trouble. Finisher control PWB trouble. Home position sensor trouble. Harness and connector connection trouble.
Check & Remedy	Use SIM3-3 to check the operation of the saddle staple motor. Check connection from the control PWB to the motor. Turn OFF/ON the power. Replace the control PWB. Replace the sensor.

**F1-47 Saddle paper transport motor trouble**

Trouble content	Abnormality in the drive roller oscillation motor in the finisher saddle transport section.
Detail	PCU
Cause	Saddle paper transport motor trouble. Finisher control PWB trouble. Harness and connector connection trouble. Fuse blown (24V line).
Check & Remedy	Use SIM3-3 to check the operation of the saddle paper transport motor. Check connection from the control PWB to the motor. Replace the control PWB. Replace the sensor.

**F1-50 Main unit - Finisher combination error**

Trouble content	
Detail	PCU
Cause	The finisher which is not supported by the main unit model is installed. Finisher control PWB trouble.
Check & Remedy	Install a proper finisher. Replace the finisher control PWB.

**F2-22 Discharge lamp trouble (K)**

Trouble content	The lamp is kept open for 1 sec from turning on the discharge lamp.
Detail	PCU
Cause	Contact trouble between the discharge lamp PWB (K) and the PCU PWB. Discharge lamp PWB (K) trouble. PCU PWB trouble.
Check & Remedy	Replace the discharge lamp PWB (K). Check the harness and the connector. Replace the PCU PWB.

**F2-23 Discharge lamp trouble (C)**

Trouble content	The lamp is kept open for 1 sec from turning on the discharge lamp.
Detail	PCU
Cause	Contact trouble between the discharge lamp PWB (C) and the PCU PWB. Discharge lamp PWB (C) trouble. PCU PWB trouble.
Check & Remedy	Replace the discharge lamp PWB (C). Check the harness and the connector. Replace the PCU PWB.

**F2-24 Discharge lamp trouble (M)**

Trouble content	The lamp is kept open for 1 sec from turning on the discharge lamp.
Detail	PCU
Cause	Contact trouble between the discharge lamp PWB (M) and the PCU PWB. Discharge lamp PWB (M) trouble. PCU PWB trouble.
Check & Remedy	Replace the discharge lamp PWB (M). Check the harness and the connector. Replace the PCU PWB.

**F2-25 Discharge lamp trouble (Y)**

Trouble content	The lamp is kept open for 1 sec from turning on the discharge lamp.
Detail	PCU
Cause	Contact trouble between the discharge lamp PWB (Y) and the PCU PWB. Discharge lamp PWB (Y) trouble. PCU PWB trouble.
Check & Remedy	Replace the discharge lamp PWB (Y). Check the harness and the connector. Replace the PCU PWB.

**F2-39 Process thermistor trouble**

Trouble content	
Detail	PCU
Cause	Process thermistor trouble. Process thermistor harness connection trouble. PCU PWB trouble.
Check & Remedy	Replace the process thermistor. Check connection of the process thermistor harness and the connector. Replace the PCU PWB.

**F2-40 Toner density sensor trouble (K)**

Trouble content	
Detail	PCU
Cause	Toner density sensor output abnormality. Sensor connector and harness connection trouble. Developing unit trouble. PCU PWB trouble.
Check & Remedy	Replace the toner density sensor. Check connection of the sensor connector and the harness. Replace the developing unit. Replace the PCU PWB.

**F2-41 Toner density sensor trouble (C)**

Trouble content	
Detail	PCU
Cause	Toner density sensor output abnormality. Sensor connector and harness connection trouble. Developing unit trouble. PCU PWB trouble.
Check & Remedy	Replace the toner density sensor. Check connection of the sensor connector and the harness. Replace the developing unit. Replace the PCU PWB.

**F2-42 Toner density sensor trouble (M)**

Trouble content	
Detail	PCU
Cause	Toner density sensor output abnormality. Sensor connector and harness connection trouble. Developing unit trouble. PCU PWB trouble.
Check & Remedy	Replace the toner density sensor. Check connection of the sensor connector and the harness. Replace the developing unit. Replace the PCU PWB.

**F2-43 Toner density sensor trouble (Y)**

Trouble content	
Detail	PCU
Cause	Toner density sensor output abnormality. Sensor connector and harness connection trouble. Developing unit trouble. PCU PWB trouble.
Check & Remedy	Replace the toner density sensor. Check connection of the sensor connector and the harness. Replace the developing unit. Replace the PCU PWB.

**F2-45 Color image density sensor trouble**

Trouble content	
Detail	PCU
Cause	Color image density sensor sensitivity adjustment trouble. Color image density sensor trouble. Sensor harness and connector connection trouble. Image density sensor dirt. Calibration plate dirt. Transfer unit lift operation trouble PCU PWB trouble.
Check & Remedy	Replace the color image density sensor. Check connection of the sensor harness and the connector. Clean the image density sensor. Replace the calibration plate. Repair the transfer unit lift mechanism. Replace the PCU PWB. Use SIM44-13 to perform the sensitivity adjustment of the process control sensor.

**F2-49 LSU thermistor trouble**

Trouble content	
Detail	PCU
Cause	The LSU temperature is outside of -28°C - 78°C. LSU thermistor trouble. LSU thermistor harness and connector connection trouble PCU PWB trouble. LSU control PWB trouble.
Check & Remedy	Replace the PCU PWB. Replace the LSU control PWB. Replace the LSU.

**F2-50 K drum phase sensor trouble**

Trouble content	
Detail	PCU
Cause	Drum phase sensor trouble. Drum phase sensor harness and connector connection trouble Drum drive section trouble. PCU PWB trouble.
Check & Remedy	Use SIM30-1 to check the operation of "DHPD_K". Replace the drum phase sensor. Check connection of the drum phase sensor harness and the connector. Repair the drum drive section. Replace the PCU PWB.

**F2-51 CL drum phase sensor trouble**

Trouble content	
Detail	PCU
Cause	Drum phase sensor trouble. Drum phase sensor harness and connector connection trouble Drum drive section trouble. PCU PWB trouble.
Check & Remedy	Use SIM30-1 to check the operation of "DHPD_CL". Replace the drum phase sensor. Check connection of the drum phase sensor harness and the connector. Repair the drum drive section. Replace the PCU PWB.

**F2-58 Temperature/humidity sensor trouble (HUD\_M/TH\_M)**

Trouble content	
Detail	PCU
Cause	Temperature/humidity sensor trouble. Process humidity sensor harness and connector connection trouble PCU PWB trouble.
Check & Remedy	Replace the temperature/humidity sensor. Check connection of the temperature/humidity sensor harness and the connector. Replace the PCU PWB.

**F2-64 Toner supply operation trouble (K)**

Trouble content	
Detail	PCU
Cause	Toner motor trouble. Toner density sensor trouble. Connector/harness trouble. PCU PWB trouble. Toner cartridge trouble. Developing unit trouble. Toner transport pipe section trouble
Check & Remedy	Replace the toner motor. Replace the toner density sensor. Connector and harness check. Replace the PCU PWB. Replace the toner cartridge. Replace the developing unit. Check the toner transport pipe section.

**F2-65 Toner supply operation trouble (C)**

Trouble content	
Detail	PCU
Cause	Toner motor trouble. Toner density sensor trouble. Connector/harness trouble. PCU PWB trouble. Toner cartridge trouble. Developing unit trouble. Toner transport pipe section trouble
Check & Remedy	Replace the toner motor. Replace the toner density sensor. Connector and harness check. Replace the PCU PWB. Replace the toner cartridge. Replace the developing unit. Check the toner transport pipe section.

**F2-66 Toner supply operation trouble (M)**

Trouble content	
Detail	PCU
Cause	Toner motor trouble. Toner density sensor trouble. Connector/harness trouble. PCU PWB trouble. Toner cartridge trouble. Developing unit trouble. Toner transport pipe section trouble
Check & Remedy	Replace the toner motor. Replace the toner density sensor. Connector and harness check. Replace the PCU PWB. Replace the toner cartridge. Replace the developing unit. Check the toner transport pipe section.

**F2-67 Toner supply operation trouble (Y)**

Trouble content	
Detail	PCU
Cause	Toner motor trouble. Toner density sensor trouble. Connector/harness trouble. PCU PWB trouble. Toner cartridge trouble. Developing unit trouble. Toner transport pipe section trouble
Check & Remedy	Replace the toner motor. Replace the toner density sensor. Connector and harness check. Replace the PCU PWB. Replace the toner cartridge. Replace the developing unit. Check the toner transport pipe section.

**F2-70 Improper toner cartridge detection (K)**

Trouble content	
Detail	PCU
Cause	An improper toner cartridge is inserted. (The main unit detects a toner cartridge of a different specification.) Toner cartridge trouble. PCU PWB trouble.
Check & Remedy	Replace the toner cartridge. Replace the PCU PWB.

**F2-71 Improper toner cartridge detection (C)**

Trouble content	
Detail	PCU
Cause	An improper toner cartridge is inserted. (The main unit detects a toner cartridge of a different specification.) Toner cartridge trouble. PCU PWB trouble.
Check & Remedy	Replace the toner cartridge. Replace the PCU PWB.

**F2-72 Improper toner cartridge detection (M)**

Trouble content	
Detail	PCU
Cause	An improper toner cartridge is inserted. (The main unit detects a toner cartridge of a different specification.) Toner cartridge trouble. PCU PWB trouble.
Check & Remedy	Replace the toner cartridge. Replace the PCU PWB.

**F2-73 Improper toner cartridge detection (Y)**

Trouble content	
Detail	PCU
Cause	An improper toner cartridge is inserted. (The main unit detects a toner cartridge of a different specification.) Toner cartridge trouble. PCU PWB trouble.
Check & Remedy	Replace the toner cartridge. Replace the PCU PWB.

**F2-74 Toner cartridge CRUM error (K)**

Trouble content	
Detail	PCU
Cause	Toner cartridge (CRUM) trouble. PCU PWB trouble. Connector and harness trouble between PCU PWB and toner cartridge
Check & Remedy	Replace the toner cartridge. Replace the PCU PWB. Check the connector and the harness between the PCU PWB and the toner cartridge.

**F2-75 Toner cartridge CRUM error (C)**

Trouble content	
Detail	PCU
Cause	Toner cartridge (CRUM) trouble. PCU PWB trouble. Connector and harness trouble between PCU PWB and toner cartridge
Check & Remedy	Replace the toner cartridge. Replace the PCU PWB. Check the connector and the harness between the PCU PWB and the toner cartridge.

**F2-76 Toner cartridge CRUM error (M)**

Trouble content	
Detail	PCU
Cause	Toner cartridge (CRUM) trouble. PCU PWB trouble. Connector and harness trouble between PCU PWB and toner cartridge
Check & Remedy	Replace the toner cartridge. Replace the PCU PWB. Check the connector and the harness between the PCU PWB and the toner cartridge.

**F2-77 Toner cartridge CRUM error (Y)**

Trouble content	
Detail	PCU
Cause	Toner cartridge (CRUM) trouble. PCU PWB trouble. Connector and harness trouble between PCU PWB and toner cartridge
Check & Remedy	Replace the toner cartridge. Replace the PCU PWB. Check the connector and the harness between the PCU PWB and the toner cartridge.

**F2-78 Registration/BK image density sensor trouble (Transfer belt substrate reflection rate abnormality)**

Trouble content	
Detail	PCU
Cause	Image density (registration) sensor trouble (Sensor sensitivity adjustment trouble). PCU PWB trouble. Image density (resist) sensor connector and harness connection trouble Image density (registration) sensor dirt. Transfer belt dirt, scratch.
Check & Remedy	Replace the image density (registration) sensor. Replace the PCU PWB. Check connection of the connector and the harness of the image density (resist) sensor. Clean the image density (registration) sensor. Clean or replace the transfer belt.

**F2-91 High density process control high voltage error (K)**

Trouble content	For the production process (Not occur in the market.)
Detail	PCU
Cause	—
Check & Remedy	—

**F2-92 High density process control high voltage error (C)**

Trouble content	For the production process (Not occur in the market.)
Detail	PCU
Cause	—
Check & Remedy	—

**F2-93 High density process control high voltage error (M)**

Trouble content	For the production process (Not occur in the market.)
Detail	PCU
Cause	—
Check & Remedy	—

**F2-94 High density process control high voltage error (Y)**

Trouble content	For the production process (Not occur in the market.)
Detail	PCU
Cause	—
Check & Remedy	—

**F3-12 Paper feed tray 1 lift operation trouble**

Trouble content	
Detail	PCU
Cause	LUD1 is not turned ON within the specified time. CLUD1 sensor trouble. Paper feed tray 1 lift unit trouble. PCU PWB trouble. Sensor harness and connector connection trouble
Check & Remedy	Check connection of the harness and the connector of LUD1. Replace the lift-up unit. Replace the PCU PWB.

**F3-22 Paper feed tray 2 lift operation trouble**

Trouble content	LUD2 does not turn ON within the specified time.
Detail	PCU
Cause	LUD2 does not turn ON within the specified time. CLUD2 sensor trouble. Paper feed tray 2 lift unit trouble. PCU PWB trouble. Sensor harness and connector connection trouble
Check & Remedy	Check the harness and the connector of LUD2. Replace the lift-up unit. Replace the PCU PWB.

**F6-00 MFPC PWB - FAX communication trouble**

Trouble content	MFP - FAX communication establishment error / Framing / Parity / Protocol error	
Section	MFP	
Case 1	Cause	FAX control PWB trouble.
	Check and Remedy	Replace the FAX control PWB.
Case 2	Cause	FAX control PWB - MFPC PWB connector and harness trouble
	Check and Remedy	Check the connector and the harness between the FAX control PWB and the MFPC PWB.
Case 3	Cause	FAX control PWB - Mother board connector and harness trouble
	Check and Remedy	Check the connector and the harness between the FAX control PWB and the mother board.
Case 4	Cause	FAX control PWB ROM trouble / ROM pin breakage
	Check and Remedy	Check the ROM of the FAX control PWB.

**F6-01 FAX control PWB EEPROM read/write error**

Trouble content	FAX control PWB EEPROM access error (Read and write)	
Section	FAX	
Case 1	Cause	FAX control PWB EEPROM trouble
	Check and Remedy	Check that no trouble occurs after replacement of EEPROM. Execute the memory check of SIM66-3 to insure that EEPROM can be accessed.
Case 2	Cause	FAX control PWB EEPROM access circuit trouble
	Check and Remedy	Replace the FAX control PWB.

**F6-04 FAX MODEM operation trouble**

Trouble content	FAX control PWB MODEM chip operation trouble	
Section	FAX	
Case 1	Cause	FAX MODEM chip operation trouble.
	Check and remedy	Replace the FAX control PWB.
Case 2	Cause	The FAX MODEM chip cannot be accessed.
	Check and Remedy	Replace the FAX control PWB.

**F6-21 Improper combination of TEL/LIU PWB and FAX soft switch**

Trouble content	Incompatibility between the TEL/LIU PWB and the FAX control PWB information (soft switch)	
Section	MFP	
Case 1	Cause	The destination of the TEL/LIU PWB installed is improper.
	Check and Remedy	Check the destination of the TEL/LIU PWB.
Case 2	Cause	TEL/LIU PWB trouble.
	Check and Remedy	Replace the TEL/LIU PWB.

**F6-30 FAX 1-chip microprocessor access error (FAX detection)**

Trouble content	FAX 1-chip microprocessor access error (Read and write)	
Section	MFP	
Case 1	Cause	Program writing trouble to the 1-chip microprocessor, or no program data written.
	Check and Remedy	Use SIM66-42 to rewrite the 1-chip microprocessor program.
Case 2	Cause	FAX 1-chip microprocessor circuit trouble.
	Check and Remedy	Replace the FAX control PWB.

### F6-97 Incompatibility between FAX control PWB and the main machine

Trouble content		Incompatibility between FAX control PWB and the main machine
Section		MFP
Case 1	Cause	The FAX control PWB installed is improper. FAX control PWB trouble.
	Check and Remedy	Install a proper FAX control PWB. Replace the FAX control PWB.

### F6-98 Incompatibility between the FAX control PWB destination and the main machine destination

Trouble content		Incompatibility between the FAX control PWB destination and the main machine destination
Section		MFP
Case 1	Cause	Incompatibility between the destination information written into the FAX control PWB EEPROM and that in the main machine (set with SIM26-6)
	Check and Remedy	1) Check the destination of the FAX control PWB. 2) Check the destination of the machine. (SIM26-6)

### F9-91 Communication error between MFP and the printer section when booting

Trouble content		Booting of the printer section cannot be recognized when booting.
Detail		MFP
Cause		MFPC (section) PWB trouble. Printer (section) PWB trouble. Printer flash ROM trouble. MFPC (section) PWB - printer (section) PWB connection trouble.
Check & Remedy		Replace the MFPC (section) PWB. Replace the printer (section) PWB. Replace the printer flash ROM. Check connection between the MFPC (section) PWB and the printer (section) PWB.

### F9-92 Printer (section) PWB hardware error

Trouble content		
Detail		Printer (section) PWB
Cause		Printer PWB trouble Font ROM contact trouble or error DIMM memory contact trouble or error
Check & Remedy		Replace the printer PWB. Check the font ROM socket. Check the DIMM memory socket. Check the font ROM. Replace the DIMM memory.

### H2-00 Thermistor open trouble (TH\_UM\_AD2)

Trouble content		
Detail		PCU
Cause		Thermistor trouble PCU PWB trouble Thermistor connector and harness connection trouble Fusing section connector connection trouble Fusing unit not installed
Check & Remedy		Use SIM44-14 to check the state of the thermistor. Replace the thermistor. Replace the PCU PWB. Check connection of the thermistor connector and the harness. Check the connector in the fusing section.

### H2-01 Thermistor open trouble (TH\_LM)

Trouble content		
Detail		PCU
Cause		Thermistor trouble PCU PWB trouble Thermistor connector and harness connection trouble Fusing section connector connection trouble Fusing unit not installed
Check & Remedy		Use SIM44-14 to check the state of the thermistor. Replace the thermistor. Replace the PCU PWB. Check connection of the thermistor connector and the harness. Check the connector in the fusing section.

### H2-02 Thermistor open trouble (TH\_US)

Trouble content		
Detail		PCU
Cause		Thermistor trouble PCU PWB trouble Thermistor connector and harness connection trouble Fusing section connector connection trouble Fusing unit not installed
Check & Remedy		Use SIM44-14 to check the state of the thermistor. Replace the thermistor. Replace the PCU PWB. Check connection of the thermistor connector and the harness. Check the connector in the fusing section.

### H2-03 Thermistor open trouble (TH\_UM\_AD1)

Trouble content		
Detail		PCU
Cause		Thermistor trouble PCU PWB trouble Thermistor connector and harness connection trouble Fusing section connector connection trouble Fusing unit not installed
Check & Remedy		Use SIM44-14 to check the state of the thermistor. Replace the thermistor. Replace the PCU PWB. Check connection of the thermistor connector and the harness. Check the connector in the fusing section.

### H3-00 Fusing section high temperature trouble (TH\_UM)

Trouble content	
Detail	PCU
Cause	The fusing temperature exceeds the specified level. Thermistor trouble PCU PWB trouble Thermistor connector and harness connection trouble HL control PWB trouble
Check & Remedy	Use SIM44-14 to check the state of the thermistor. Use SIM5-2 to check the flashing operation of the heater lamp. Use SIM14 to cancel the trouble. Replace the thermistor. Replace the PCU PWB. Check connection of the thermistor connector and the harness. Replace the HL control PWB.

### H3-01 Fusing section high temperature trouble (TH\_LM)

Trouble content	
Detail	PCU
Cause	The fusing temperature exceeds the specified level. Thermistor trouble PCU PWB trouble Thermistor connector and harness connection trouble HL control PWB trouble
Check & Remedy	Use SIM44-14 to check the state of the thermistor. Use SIM5-2 to check the flashing operation of the heater lamp. Use SIM14 to cancel the trouble. Replace the thermistor. Replace the PCU PWB. Check connection of the thermistor connector and the harness. Replace the HL control PWB.

### H3-02 Fusing section high temperature trouble (TH\_US)

Trouble content	
Detail	PCU
Cause	The fusing temperature exceeds the specified level. Thermistor trouble PCU PWB trouble Thermistor connector and harness connection trouble HL control PWB trouble
Check & Remedy	Use SIM44-14 to check the state of the thermistor. Use SIM5-2 to check the flashing operation of the heater lamp. Use SIM14 to cancel the trouble. Replace the thermistor. Replace the PCU PWB. Check connection of the thermistor connector and the harness. Replace the HL control PWB.

### H4-00 Fusing section low temperature trouble (TH\_UM\_AD2)

Trouble content	The fusing temperature does not reach the specified level within the specified time from turning ON the power relay.
Detail	PCU
Cause	Thermistor trouble. Heater lamp trouble. PCU PWB trouble. Thermostat trouble. Connector, harness connection trouble. HL control PWB trouble. Power unit trouble.
Check & Remedy	Use SIM14 to cancel the trouble. Use SIM44-14 to check the state of the thermistor. Use SIM5-2 to check the flashing operation of the heater lamp. Replace the thermistor. Replace the heater lamp. Replace the PCU PWB. Replace the thermostat. Check connection of the connector and the harness. Replace the HL control PWB. Replace the power unit.

### H4-01 Fusing section low temperature trouble (TH\_LM)

Trouble content	The fusing temperature does not reach the specified level within the specified time from turning ON the power relay.
Detail	PCU
Cause	Thermistor trouble. Heater lamp trouble. PCU PWB trouble. Thermostat trouble. Connector, harness connection trouble. HL control PWB trouble. Power unit trouble.
Check & Remedy	Use SIM14 to cancel the trouble. Use SIM44-14 to check the state of the thermistor. Use SIM5-2 to check the flashing operation of the heater lamp. Replace the thermistor. Replace the heater lamp. Replace the PCU PWB. Replace the thermostat. Check connection of the connector and the harness. Replace the HL control PWB. Replace the power unit.



#### H4-02 Fusing section low temperature trouble (TH\_US)

Trouble content	The fusing temperature does not reach the specified level within the specified time from turning ON the power relay.
Detail	PCU
Cause	Thermistor trouble. Heater lamp trouble. PCU PWB trouble. Thermostat trouble. Connector, harness connection trouble. HL control PWB trouble. Power unit trouble.
Check & Remedy	Use SIM14 to cancel the trouble. Use SIM44-14 to check the state of the thermistor. Use SIM5-2 to check the flashing operation of the heater lamp. Replace the thermistor. Replace the heater lamp. Replace the PCU PWB. Replace the thermostat. Check connection of the connector and the harness. Replace the HL control PWB. Replace the power unit.

#### H5-01 5 times continuous POD1 not-reach jam

Trouble content	
Detail	PCU
Cause	A fusing jam is not canceled completely. (A jam paper remains.) POD1 sensor trouble Fusing unit installation trouble POD1 sensor connector and harness connection trouble PCU PWB trouble Fusing unit, drive section trouble
Check & Remedy	Replace the POD1 sensor. Check installation of the fusing unit. Replace the fusing unit. Check or repair the fusing drive section. Check connection of the POD1 sensor connector and the harness. Replace the PCU PWB. Use SIM14 to cancel the trouble.

#### H7-10 Recovery error from low fuser temp. (TH\_UM\_AD2)

Trouble content	The fusing temperature does not reach the specified level within the specified time from stopping a job due to fall in the fusing temperature.
Detail	PCU
Cause	Thermistor trouble. Heater lamp trouble. PCU PWB trouble. Thermostat trouble. Connector, harness connection trouble. HL control PWB trouble. Power unit trouble.
Check & Remedy	Replace the thermistor. Replace the heater lamp. Replace the PCU PWB. Replace the thermostat. Check connection of the connector and the harness. Replace the HL control PWB. Replace the power unit. Use SIM5-2 to check the flashing operation of the heater lamp.

#### H7-11 Recovery error from low fuser temp. (TH\_LM)

Trouble content	The fusing temperature does not reach the specified level within the specified time from stopping a job due to fall in the fusing temperature.
Detail	PCU
Cause	Thermistor trouble. Heater lamp trouble. PCU PWB trouble. Thermostat trouble. Connector, harness connection trouble. HL control PWB trouble. Power unit trouble.
Check & Remedy	Replace the thermistor. Replace the heater lamp. Replace the PCU PWB. Replace the thermostat. Check connection of the connector and the harness. Replace the HL control PWB. Replace the power unit. Use SIM5-2 to check the flashing operation of the heater lamp.

#### L1-00 Scanner feed trouble

Trouble content	Scanner feed is not completed within the specified time.
Detail	SCU
Cause	Scanner unit trouble. SCU PWB trouble. Scanner control PWB trouble. Harness and connector connection trouble. Scanner home position sensor trouble. Scanner motor trouble.
Check & Remedy	Use SIM1-1 to check the scan operation. Replace the scanner unit. Replace the SCU PWB. Check connection of the connectors and the harness. Replace the scanner home position sensor. Replace the scanner motor.

#### L3-00 Scanner return trouble

Trouble content	Scanner return is not completed within the specified time.
Detail	SCU
Cause	Scanner unit trouble SCU PWB trouble Scanner control PWB trouble Harness and connector connection trouble Scanner home position sensor trouble Scanner motor trouble
Check & Remedy	Use SIM1-1 to check the scan operation. Replace the scanner unit. Replace the SCU PWB. Check connection of the connectors and the harness. Replace the scanner home position sensor. Replace the scanner motor.

#### L4-02 Paper feed motor trouble

Trouble content	A lock signal is not detected within the specified time in ON operation of the paper feed motor after warming-up or canceling a jam.
Detail	PCU
Cause	Paper feed motor trouble Paper feed motor harness and connector connection trouble PCU PWB trouble
Check & Remedy	Use SIM6-1 to check the operation of the paper feed motor. Replace the paper feed motor. Check connection of the paper feed motor harness and the connector. Replace the PCU PWB.

#### L4-03 Fusing motor trouble

Trouble content	The motor lock signal is detected during rotation of the fusing motor.
Detail	PCU
Cause	Fusing motor trouble Fusing motor harness and connector connection trouble PCU PWB trouble
Check & Remedy	Use SIM6-1 to check the operation of the fusing motor. Replace the Fusing motor. Check connection of the fusing motor harness and the connection. Replace the PCU PWB.

#### L4-04 Developing motor trouble (BLACK)

Trouble content	The motor lock signal is detected during rotation of the developing motor.
Detail	PCU
Cause	Developing motor trouble Developing motor harness and connector connection trouble PCU PWB trouble Developing unit trouble
Check & Remedy	Use SIM25-1 to check the operation of the developing motor. Replace the developing motor. Check connection of the developing motor harness and the connection. Replace the PCU PWB. Replace the developing motor. Replace the developing unit.

#### L4-05 Developing motor trouble (COLOR)

Trouble content	The motor lock signal is detected during rotation of the developing motor.
Detail	PCU
Cause	Developing motor trouble Developing motor harness and connector connection trouble PCU PWB trouble Developing unit trouble
Check & Remedy	Use SIM25-1 to check the operation of the developing motor. Replace the developing motor. Check connection of the developing motor harness and the connection. Replace the PCU PWB. Replace the developing motor. Replace the developing unit.

#### L4-06 Transfer unit lift trouble

Trouble content	A change in the primary transfer position sensor cannot be detected within the specified time in lifting operation of the primary transfer unit.
Detail	PCU
Cause	Transfer unit position sensor trouble Dirt on the transfer unit position sensor. PCU PWB trouble Connection trouble of the connector and the harness. Transfer unit lift mechanism trouble Primary transfer belt unit is not installed.
Check & Remedy	Use SIM6-3 to check the separating operation of the transfer unit. Install the primary transfer belt unit. Replace the transfer unit position sensor. Clean the transfer unit position sensor. Replace the PCU PWB. Check connection of the connector and the harness. Repair the transfer unit lift mechanism.

#### L4-07 Transfer belt motor trouble

Trouble content	
Detail	PCU
Cause	The motor lock signal is detected during rotation of the transfer belt motor. Transfer belt motor trouble Transfer belt motor harness and connector connection trouble PCU PWB trouble
Check & Remedy	Use SIM25-1 to check the operation of the transfer belt motor. Check the transfer belt motor, and replace if necessary. Check connection of the harness and connectors of the transfer belt motor, and replace if necessary. Check the PCU PWB, and replace if necessary.

#### L4-11 Shift motor trouble

Trouble content	No change in the shifter home position sensor signal is detected in the operation of the shifter initializing.
Detail	PCU
Cause	Shift motor trouble. PCU PWB trouble. Connection trouble of the connector and the harness. Shifter home position sensor trouble.
Check & Remedy	Use SIM6-1 to check the shift operation. Use SIM30-1 to check the operation of the shifter home position sensor. Replace the shift motor. Replace the PCU PWB. Check connection of the connector and the harness. Replace the shifter home position sensor.

**L4-12 Secondary transfer separation trouble**

Trouble content	A change in the separation sensor status cannot be detected within the specified time in separation operation of the secondary transfer.
Detail	PCU
Cause	Secondary transfer separation mechanism trouble. Secondary transfer separation clutch trouble. Secondary transfer separation sensor trouble. Connection trouble of the connector and the harness. PCU PWB trouble.
Check & Remedy	Check or repair the secondary transfer separation mechanism. Replace the secondary transfer separation clutch. Replace the secondary transfer separation sensor. Replace the PCU PWB. Check connection of the connector and the harness.

**L4-16 Fusing pressure release trouble**

Trouble content	A change in the fusing pressure release sensor signal cannot be detected within the specified time after outputting the fusing pressure release motor.
Detail	PCU
Cause	Fusing pressure release sensor trouble. Fusing pressure release motor trouble. Pressure release drive gear and pressure release idle gear trouble. PCU PWB trouble. Connection trouble of the connector and the harness.
Check & Remedy	Replace the fusing pressure release sensor. Replace the fusing pressure release motor. Replace the pressure release drive gear and the pressure release idle gear. Replace the PCU PWB. Check connection of the connector and the harness.

**L4-31 Paper exit cooling fan trouble**

Trouble content	The fan operation signal is not detected.
Detail	PCU
Cause	Paper exit cooling fan trouble. PCU PWB trouble Connection trouble of the connector and the harness.
Check & Remedy	Check connection of the connectors and the harness. Use SIM6-2 to check the rotating operation of the fan. Replace the paper exit cooling fan. Replace the PCU PWB.

**L4-32 Power source cooling fan trouble**

Trouble content	The fan operation signal is not detected.
Detail	PCU
Cause	Power cooling fan trouble. PCU PWB trouble. Connection trouble of the connector and the harness.
Check & Remedy	Use SIM6-2 to check that the fan is actually rotating. Replace the power cooling fan. Replace the PCU PWB. Check connection of the connectors and the harness.

**L4-34 LSU cooling fan trouble**

Trouble content	
Detail	PCU
Cause	When the LSU cooling fan is operated, the fan operation signal is not detected within the specified time. LSU fan trouble. Harness, connector trouble. LSU mother PWB trouble.
Check & Remedy	Use SIM6-2 to check the fan operation. Check the LSU fan, and replace if necessary. Check the harness/connector, and replace if necessary. Check the LSU mother PWB, and replace if necessary.

**L4-35 Fusing cooling fan trouble**

Trouble content	The fan operation signal is not detected.
Detail	PCU
Cause	Fusing cooling fan trouble. PCU PWB trouble. Connection trouble of the connector and the harness.
Check & Remedy	Use SIM6-2 to check that the fan is actually rotating. Replace the fusing cooling fan. Replace the PCU PWB. Check connection of the connector and the harness.

**L4-43 Paper exit cooling fan 2 trouble**

Trouble content	The fan operation signal is not detected.
Detail	PCU
Cause	Paper exit cooling fan trouble. (Machine R side) PCU PWB trouble. Connection trouble of the connector and the harness.
Check & Remedy	Replace the fan. Replace the PCU PWB. Check the connector and the harness. Use SIM6-2 to check that the fan is actually rotating.

**L4-50 Process fan trouble**

Trouble content	The fan operation signal is not detected.
Detail	PCU
Cause	Process fan trouble. PCU PWB trouble. Connection trouble of the connector and the harness.
Check & Remedy	Check that the fan is rotating after turning ON the power. Replace the process fan. Replace the PCU PWB. Check connection of the connector and the harness.

**L4-51 Process fan 2 trouble**

Trouble content	The fan operation signal is not detected.
Detail	PCU
Cause	Fan trouble. PCU PWB trouble. Connection trouble of the connector and the harness.
Check & Remedy	Replace the fan. Replace the PCU PWB. Check the connector and the harness. Check that the fan is rotating after turning ON the power.

**L6-10 Polygon motor trouble**

Trouble content	The polygon motor does not reach the specified RPM within the specified time after starting rotation of the polygon motor.
Detail	PCU
Cause	Polygon motor trouble. LSU mother PWB trouble. Connection trouble of the connector and the harness.
Check & Remedy	Use SIM61-1 to check the operation of the polygon motor. Check connection of the connector and the harness. Replace the LSU. Replace the LSU mother PWB.

**L8-01 Full wave signal detection error**

Trouble content	The full wave signal is not detected.
Detail	PCU
Cause	PCU PWB trouble. Power unit trouble. Connection trouble of the connector and the harness.
Check & Remedy	Replace the PCU PWB. Replace the power unit. Check connection of the connector and the harness.

**L8-20 Communication error of MFPC PWB/LSU mother board**

Trouble content	
Detail	MFP
Cause	LSU mother board PWB - MFPC PWB connection trouble. MFPC PWB trouble. LSU mother board trouble.
Check & Remedy	Check connection between the LSU mother board PWB and the MFPC PWB. Check the ground of the main unit. Replace the MFPC PWB. Replace the LSU mother board.

**P1-00 PCI communication error**

Trouble content	
Detail	MFP
Cause	Communication error between the MFPC PWB and the PCI. Connection failure of connectors and harness between the MFPC PWB and the PCI. MFPC PWB trouble. PCI control PWB trouble.
Check & Remedy	Check connection of the harness and connectors between the MFPC PWB and the PCI. Check the MFPC PWB, and replace if necessary. (Refer to the necessary procedures after replacement of the MFPC PWB in the Service Manual, and perform the procedures.) Check the PCI control PWB, and replace if necessary.

**P1-01 PCI fan error**

Trouble content	
Detail	MFP
Cause	The PCI fan operation signal is not detected. PCI fan trouble. PCI control PWB trouble.
Check & Remedy	Check connection of the connectors and harness between the PCI fan and the PCI control PWB. Check the PCI control PWB, and replace if necessary. Check the PCI fan, and replace if necessary.

**P1-02 Plasma generating device error**

Trouble content	
Detail	MFP
Cause	Connection failure of connectors and harness between the plasma generating device and the PCI control PWB. Plasma generating device trouble. PCI control PWB trouble.
Check & Remedy	Check connection of the connectors and harness between the plasma generating device and the PCI control PWB. Replace the plasma generating device. Check the PCI control PWB, and replace if necessary.

**PC-- Personal counter not detected**

Trouble content	
Detail	MFP
Cause	The personal counter is not installed. The personal counter is not detected. SCU PWB trouble.
Check & Remedy	Check connection of the connectors and the harness. Replace the SCU PWB.

**U1-01 Battery trouble**

Trouble content	RTC backup battery voltage fall
Detail	MFP
Case 1	Cause 1) Battery life 2) Battery circuit abnormality
	Check and Remedy Check to confirm that the battery voltage is about 2.5V or above. Replace the battery.

**U2-00 MFP EEPROM read/write error**

Trouble content	
Detail	MFP
Cause	MFPC PWB EEPROM trouble EEPROM socket contact trouble MFPC PWB trouble Strong external noises.
Check & Remedy	Replace the MFPC PWB EEPROM. Replace the MFPC PWB. (Refer to the pages on the necessary works after replacing the MFPC PWB in the Service Manual, and perform the works.) Check the power environment.

**U2-05 HDD/MFPC PWB SRAM contents inconsistency (18cpm/20cpm/23cpm/31cpm(G) machine)**

Trouble content	The HDD or the MFPC PWB installed is improper. (Erroneous detection of account management data)
Detail	MFP
Cause	The HDD was replaced. The MFPC PWB was replaced. HDD trouble MFPC PWB trouble
Check & Remedy	(Refer to the pages on the necessary works after replacing the HDD and the MFPC PWB in the Service Manual, and perform the works.) Use SIM16 to cancel the error.

**U2-05 Erroneous detection of account management data / HDD internal authentication DB table error (26cpm/36cpm/31cpm(A) machine)**

Trouble content	
Detail	MFP
Cause	The HDD internal authentication DB table is broken. After detection of the broken authentication DB table, the machine is rebooted to rebuild the authentication table. This error can be confirmed only by the error history of SIM22-4. If frequent occurrence of this error is found, the following devices may possibly be damaged. HDD trouble MFPC PWB trouble
Check & Remedy	Check the HDD, and replace if necessary. Check the MFPC PWB, and replace if necessary. When replacing the HDD and the MFPC PWB, refer to "Necessary works and procedures for replacement of HDD and MFPC PWB" and perform the necessary procedures. If this error does not occur frequently, the above procedure is not required.

**U2-10 MFPC PWB SRAM user authentication index check sum error**

Trouble content	
Detail	MFP
Cause	SRAM user index information (user authentication basic data) check sum error. MFPC PWB SRAM trouble. MFPC PWB trouble. Strong external noises.
Check & Remedy	Use SIM16 to cancel the error. (Index information data in the HDD are transferred to the SRAM.) Replace the MFPC PWB. (Refer to the pages on the necessary works after replacing the MFPC PWB in the Service Manual, and perform the works.)

**U2-11 MFPC PWB EEPROM counter check sum error**

Trouble content	
Detail	MFP
Cause	MFPC PWB EEPROM trouble EEPROM socket contact trouble MFPC PWB trouble Strong external noises.
Check & Remedy	Use SIM16 to cancel the error. (The previous writing data (about the latest 8 sheets) are written into the EEPROM.) Replace the MFPC PWB. (Refer to the pages on the necessary works after replacing the MFPC PWB in the Service Manual, and perform the works.)

**U2-24 MFPC PWB SRAM memory user authentication counter check sum error**

Trouble content	
Detail	MFP
Cause	MFPC PWB SRAM trouble MFPC PWB trouble Strong external noises.
Check & Remedy	Use SIM16 to cancel the error. (The check sum error detection data are calculated again to reset the proper check sum data.) Replace the MFPC PWB. (Refer to the pages on the necessary works after replacing the MFPC PWB in the Service Manual, and perform the works.)

**U2-30 MFPC PWB and PCU PWB manufacturing No. data inconsistency**

Trouble content	Inconsistency between the manufacturing No. saved in the PCU PWB and that in the MFPC PWB.
Detail	MFP
Cause	When replacing the PCU PWB or the MFPC PWB, the EEPROM which was mounted on the PWB before replacement is not mounted on the new PWB. MFPC PWB trouble PCU PWB trouble
Check & Remedy	Check that the EEPROM is properly set. Check to confirm that the EEPROM which was mounted on the PWB before replacement is mounted on the new PWB. Replace the MFPC PWB. (Refer to the pages on the necessary works after replacing the MFPC PWB in the Service Manual, and perform the works.) Replace the PCU PWB.

**U2-40 SD card system storage data area error**

Trouble content	
Detail	MFP
Cause	A file error occurs in the SD card system storage data partition. SD card trouble MFPC PWB trouble
Check & Remedy	Turn OFF/ON the power, and the backup data in the HDD are written into the SD card and the machine is automatically booted. Check the MFPC PWB, and replace if necessary. Check the SD card, and replace if necessary.

## U2-41 HDD system storage data area error

Trouble content	
Detail	MFP
Cause	A file error occurs in the HDD system saved data area, disabling backup of the saved file of the machine adjustment values in the SD card. HDD trouble MFPC PWB trouble
Check & Remedy	Check the HDD, and replace if necessary. Check the MFPC PWB, and replace if necessary. When replacing the HDD and the MFPC PWB, refer to the chapter of "Necessary works and procedures of HDD and MFPC PWB replacement."

## U2-42 Machine adjustment data (system storage data area) error

Trouble content	
Detail	MFP
Cause	The saved file of the machine adjustment values in the SD card and the HDD cannot be found or is broken. Both of the SD card set data and the HDD system saved data area are broken. HDD trouble MFPC PWB trouble SD card trouble
Check & Remedy	Check the HDD, and replace if necessary. Check the MFPC PWB, and replace if necessary. Check the SD card, and replace if necessary. When replacing the HDD, the MFPC PWB, and the SD card, refer to the chapter of "Necessary works and procedures of HDD, MFPC PWB, and SD card replacement." Use SIM to adjust the machine again and set the adjustment values.

## U2-50 HDD\*1 user authentication data check sum error

Trouble content	
Detail	MFP
Cause	HDD trouble*1 MFPC PWB trouble Strong external noises.
Check & Remedy	Check the data related to the check sum error (address book, image send system registration data (senders record, meta data)) and register again. Use SIM16 to cancel the U2 trouble. Replace the HDD*1. Replace the MFPC PWB. (Refer to the pages on the necessary works after replacing the HDD and the MFPC PWB in the Service Manual, and perform the works.)*1

\*1: SD card when no HDD is installed.

## U2-60 Watermark check error

Trouble content	
Detail	MFP
Cause	Watermark data trouble HDD trouble MFPC PWB trouble
Check & Remedy	Use SIM16 to cancel the U2 trouble. Use SIM49-5 to install the watermark data. Replace the HDD. Replace the MFPC PWB. (Refer to the pages on the necessary works after replacing the HDD and the MFPC PWB in the Service Manual, and perform the works.)

## U2-80 SCU PWB EEPROM read/write error

Trouble content	
Detail	SCU
Cause	SCU PWB EEPROM trouble SCU PWB trouble SCU PWB EEPROM socket connection trouble
Check & Remedy	Replace the SCU PWB EEPROM. Replace the SCU PWB. Check connection of the SCU PWB EEPROM socket. Check the SIM adjustment value of the following items, and adjust again if they are improper. <ul style="list-style-type: none"><li>• Scanner-related adjustments</li><li>• Touch panel-related adjustments</li></ul> Use SIM16 to cancel the trouble.

## U2-81 SCU PWB EEPROM check sum error

Trouble content	
Detail	SCU
Cause	SCU PWB EEPROM trouble. Installation of non-initialized EEPROM. SCU PWB trouble. EEPROM socket contact trouble.
Check & Remedy	Replace the SCU PWB EEPROM. Replace the SCU PWB. Check contact of the EEPROM socket. Use SIM16 to cancel the trouble. (The check sum error detection data are calculated again to reset the proper check sum data.)

## U2-90 PCU PWB EEPROM read/write error

Trouble content	
Detail	PCU
Cause	PCU PWB EEPROM trouble PCU PWB trouble EEPROM socket contact trouble
Check & Remedy	Replace the PCU PWB EEPROM. Check the SIM adjustment values of the engine, and adjust again if they are improper. Replace the PCU PWB. Check contact of the EEPROM socket. Use SIM16 to cancel the trouble.

**U2-91 PCU PWB EEPROM check sum error**

Trouble content	
Detail	PCU
Cause	PCU PWB EEPROM trouble PCU PWB trouble EEPROM socket contact trouble
Check & Remedy	Replace the PCU PWB EEPROM. Replace the PCU PWB. Check contact of the EEPROM socket. Use SIM16 to cancel the trouble. (The check sum error detection data are calculated again to reset the proper check sum data.)

**U6-00 PCU PWB - Paper feed desk (paper feed tray 3, 4) communication trouble**

Trouble content	
Detail	PCU
Cause	Connection trouble of the connector and the harness. Paper feed desk control PWB trouble PCU PWB trouble
Check & Remedy	Check connection of the connector and the harness. Replace the paper feed desk control PWB. Replace the PCU PWB.

**U6-01 Desk paper feed tray 1 lift trouble**

Trouble content	D1ULD does not turn ON within the specified time when lift-up operation.
Detail	PCU
Cause	D1ULD sensor trouble. Desk control PWB trouble. Lift unit trouble. Connection trouble of the connector and the harness. PCU PWB trouble.
Check & Remedy	Replace the D1ULD sensor. Replace the desk control PWB. Replace the lift unit. Check connection of the connector and the harness. Replace the PCU PWB.

**U6-02 Desk paper feed tray 2 lift trouble**

Trouble content	D2ULD does not turn ON within the specified time when lift-up operation.
Detail	PCU
Cause	D2ULD sensor trouble Desk control PWB trouble Lift unit trouble Connection trouble of the connector and the harness. PCU PWB trouble
Check & Remedy	Replace the D2ULD sensor. Replace the desk control PWB. Replace the lift unit. Check connection of the connector and the harness. Replace the PCU PWB.

**U6-09 LCC lift motor trouble**

Trouble content	No variation in the motor rotation sensor signal (encoder sign) is detected within the specified time after booting or stopping the LCC lift motor.
Detail	PCU
Cause	LCC lift motor rotation sensor trouble LCC control PWB trouble LCC lift mechanism trouble LCC lift motor trouble
Check & Remedy	Use SIM4-2 and 4-3 to check the operation of the LCC sensor and the lift motor. Check the LCC lift motor rotation sensor, and replace if necessary. Check the LCC control PWB, and replace if necessary. Check the LCC lift mechanism, and repair if necessary. Check the LCC lift motor, and replace if necessary. Use SIM15 to cancel the trouble.

**U6-10 Desk paper feed unit paper transport motor trouble**

Trouble content	
Detail	PCU
Cause	Desk paper feed motor trouble (motor lock, motor rpm abnormality, over-current to the motor). Desk control PWB trouble Connection trouble of the connector and the harness.
Check & Remedy	Use SIM4-3 to check the operation of the desk transport motor. Replace the desk control PWB. Replace the desk paper feed motor. Check connection of the connector and the harness.

**U6-20 LCC control PWB - PCU PWB communication error**

Trouble content	.
Detail	PCU
Cause	Communication error between the LCC control PWB and the PCU PWB. Connection trouble of the harness and the connector between the machine and the LCC and those of the LCC control PWB. LCC control PWB trouble PCU PWB trouble Malfunction due to noises.
Check & Remedy	Check to confirm the LCC model. Check the connection of the harness and the connector between the machine and the LCC and those of the LCC control PWB, and replace if necessary. Check the LCC control PWB, and replace if necessary. Check the PCU PWB, and replace if necessary.

**U6-21 LCC transport motor trouble**

Trouble content	No variation in the motor rotation sensor signal (encoder sign) is detected within the specified time after booting or stopping the LCC transport motor.
Detail	PCU
Cause	LCC transport motor rotation sensor trouble LCC control PWB trouble LCC paper transport mechanism trouble LCC paper transport motor trouble
Check & Remedy	Use SIM4-3 to check the operation of the LCC transport motor. Check the LCC transport motor rotation sensor, and replace if necessary. Check the LCC control PWB, and replace if necessary. Check the LCC paper transport mechanism, and replace if necessary. Check the LCC transport motor, and replace if necessary.

**U6-22 LCC 24V power trouble**

Trouble content	The power voltage of DC24V is not supplied to the LCC unit.
Detail	PCU
Cause	Connection trouble of the harness and the connector between the machine and the LCC and those of the LCC control PWB. LCC control PWB trouble Machine power unit trouble
Check & Remedy	Check the connection of the harness and the connector between the machine and the LCC and those of the LCC control PWB, and replace if necessary. Check the LCC control PWB, and replace if necessary. Check the machine power unit, and replace if necessary.

**U6-50 Desk - Main unit combination trouble**

Trouble content	
Detail	PCU
Cause	Improper combination between the main unit and the desk. Desk control PWB trouble.
Check & Remedy	Install a desk which is proper for the main unit mode. Replace the desk control PWB.

**U6-51 LCC - Main unit combination trouble**

Trouble content	An LCC of a different model which is not supported by the machine is installed. (Improper combination of the machine and the LCC model code.)
Detail	PCU
Cause	LCC control PWB trouble PCU PWB trouble
Check & Remedy	Check to confirm the LCC model. Check the LCC control PWB, and replace if necessary. Check the PCU PWB, and replace if necessary.

**U6-52 PCU PWB - Paper feed desk (paper feed tray 2) communication trouble**

Trouble content	Paper feed tray 2 (desk unit) is not recognized.
Detail	PCU
Cause	Connection failure between the machine and paper feed tray 2 (desk unit) PCU PWB trouble.
Check & Remedy	Check connection of the connector and the harness. Replace the PCU PWB.

**U7-50 MFPC PWB - Vendor machine communication error**

Trouble content	Communication error between the MFP and the serial vendor.
Detail	MFP
Cause	Improper setting of the vendor machine specifications (SIM26-3). Vendor machine trouble. MFPC PWB trouble. Connector, harness connection trouble. Strong external noises.
Check & Remedy	Cancel the error by turning OFF/ON the power. Check the connector and the harness in the communication line. Change the specifications of the vendor machine (SIM26-3). Replace the MFPC PWB.

**U7-51 Vendor machine error**

Trouble content	
Detail	MFP (Notification of a trouble from the serial vendor)
Cause	Serial vendor machine trouble. Connector, harness connection trouble.
Check & Remedy	Err.XX is displayed on the operation panel of the vendor. (XX is the detail code.) Repair the vendor machine referring to the detail code. Check the connector and the harness in the communication line.

**UC-02 CPT - ASIC error**

Trouble content	
Detail	SCU
Cause	SCU PWB trouble. (CPT-ASIC trouble.)
Check & Remedy	Replace the SCU PWB.

**UC-20 DOCC ASIC error**

Trouble content	
Detail	SCU
Cause	SCU PWB trouble. (DOCC-ASIC trouble.)
Check & Remedy	Replace the SCU PWB.



**(1) Descriptions on E7-91 - 94 errors**

Two-digit numbers with double parentheses are added to E7-91 - 94 error codes recorded in SIM22-6 indicate the detailed contents of the errors.

The number in each digit has its own meaning.

(Example) E7-91(\*\*)

The upper digit of the added code indicates the job kind at the occurrence of the error.

Error code	The upper digit of the added code	Image type	Job kind at the occurrence of the error	
E7-91	0*	Other	• FAX (Internet FAX) reception print (Other than long size images)	*1
	1*	JPEG		*1
	2*	JBIG		*1
	3*	Mxx1ch		
	4*	Mxx4ch		
	5*	Other	• FAX (Internet FAX) reception print (Long size images)	*1
	6*	JPEG		*1
	7*	JBIG		*1
	8*	Mxx1ch		
	9*	Mxx4ch		
A* - F*	Not Used		*1	
E7-92	0*	Other	• OC copy (in Non ERDH)	*1
	1*	JPEG		
	2*	JBIG		*1
	3*	Mxx1ch		*1
	4*	Mxx4ch		
5* - F*	Not Used		*1	
E7-93	0*	Other	• Copy print (in ERDH) • Copy composing system function (Custom Stamp, Water mark)	*1
	1*	JPEG		
	2*	JBIG		
	3*	Mxx1ch		*1
	4*	Mxx4ch		
	5*	Other	• Image send • Document filing • Preview display	*1
	6*	JPEG		
	7*	JBIG		
	8*	Mxx1ch		
	9*	Mxx4ch		
	A*	Other	• GDI/PCL printer print • Copy composing system function (Custom Stamp, Water mark)	*1
	B*	JPEG		
	C*	JBIG		
	D*	Mxx1ch		*1
	E*	Mxx4ch		
F*	Not Used	*1		
E7-94	0*	Other	• Backup restore (Filing data import)	*1
	1*	JPEG		
	2*	JBIG		*1
	3*	Mxx1ch		*1
	4*	Mxx4ch		*1
5* - F*	Not Used		*1	

\*1: Added code without generating

The lower digit of the added code indicates the kind and the content of the abnormality or the result of the automatic memory check executed when the abnormality is detected.

		Lower digit of the added code → Kind/Content of the error							
		*1	*9	*A	*B	*C	*D	*E	*F
		Memory verify NG	—	Huffman code error	Restart marker error	Improper marker error	Head decoding error detection (ASIC detection)	Head decoding error detection (CPU detection)	Other abnormal termination
The upper digit of the added code ↓ Error detection circuit	1*, 6*, B*	JPEG	●	—	○	○	○	—	○
	2*, 7*, C*	JBIG	●	—	—	○	○	—	○
	3*, 8*, D*	Mxx1ch	●	—	—	—	—	—	○
	4*, 9*, E*	Mxx4ch	●	—	—	—	—	—	○

- : Added code indicating that the memory and its peripheral must be focused for check in case of an error.
- : Added code indicating that doubtful sections are in a wider range such as the memory, PWB's, HDD, etc.
- : Added code without generating

**(2) Countermeasures in case of E7-91 - 94**  
**In case of E7-9x (11), E7-9x (21), E7-9x (31), E7-9x (41)**

Cause	In case of E7-91 - 94, the DIMM memory (DRAM) is automatically read/written to perform a simplified check. If an abnormality is detected in that case, the added code becomes (*1). Therefore, there is a strong possibility that an abnormality lies around the memory.
Check and remedy	<ul style="list-style-type: none"> <li>• Check the installing state of the DIMM memory and the MFPC PWB to insure that there is no abnormality. (Disconnect and connect the DIMM memory and the MFPC PWB to check to insure that there is no error occurring again.)</li> <li>• Use SIM60-01 (Memory read/write check) to check to insure that no error occurs.</li> <li>• Replace the DIMM memory.</li> <li>• Replace the MFPC PWB.</li> </ul>

**Note**

Since the automatic memory check executed when E7-91 - 94 occurs is a simplified check, it cannot detect an abnormality with absolute certainty.

If the added code is (\*1), there may be a memory abnormality. Even if it is not (\*1), however, it cannot be said that there is no abnormality around the memory.

**Other added codes**

Cause	Mostly because the data inputted to the ASIC for decoding are broken for some reasons. There is an abnormality in the process of read/write of the process data in the memory or the hard disk. A great noise unexpectedly generated may be the cause. For the cases of FAX or Internet FAX reception data, when broken data are saved, printing is performed every time when the machine is booted, generating an error repeatedly. (E7-91) (To clear the received data, execute SIM66-10.)
Check and remedy	<ul style="list-style-type: none"> <li>• Check the DIMM memory, the MFPC PWB, and the HDD to insure that there is no abnormality.</li> <li>• When the job at occurrence of an error is FAX (E7-91), check the installing state of the FAX control PWB and the SC CARD PWB.</li> <li>• Perform SIM60-01 (Memory read/write check) to insure that there is no NG.</li> <li>• Perform SIM62-02 and SIM62-03 (HDD read/write check) to insure that there is no NG. (It is not required, however, when the job at occurrence of an error is FAX.)</li> <li>• Check the installing state of the DIMM memory and the MFPC PWB to insure that there is no abnormality. (Disconnect and connect the DIMM memory and the MFPC PWB to check to insure that there is no error occurring again.)</li> <li>• Replace the HDD.</li> <li>• Replace the FAX control PWB.</li> <li>• Replace the DIMM memory.</li> <li>• Replace the MFPC PWB.</li> <li>• Replace the SD card.</li> </ul>

**Note**

When there is an abnormality around the HDD, E7-03 may occur.  
If error E7-91 - 94 as well as E7-03 occurs, there is a high possibility that the error can be removed by replacing the HDD and the MFPC PWB.

**(3) Countermeasures against the case where nothing is displayed when the machine is booted**

**[Trouble content]**

If nothing is displayed when the machine is booted, the error code cannot be checked and the cause is hard to identify.

One of the causes may be an abnormality in the boot program of the SD card. To check that, the following method is used.

**[Check method]**

Check to confirm that the LED (red) under the CPU heat sink on the MFPC PWB shown in the figure below is lighted when the power is supplied.

If the LED is lighted, it is judged as an abnormality of the SD card.

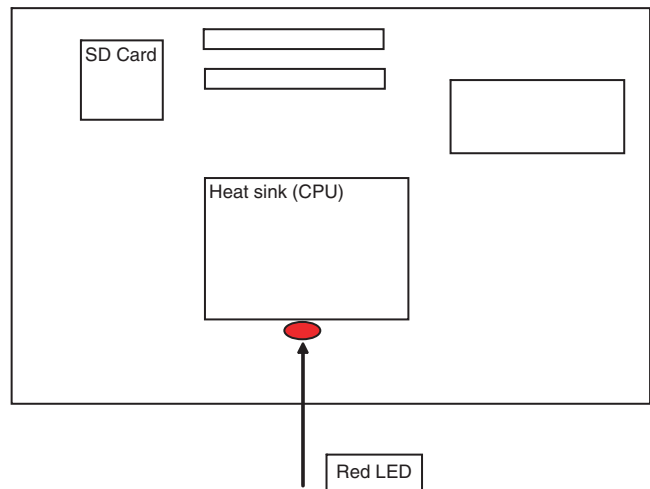

**[Countermeasures]**

- 1) Replace the SD card with a new one. (Be sure to use a service part.)
- 2) Upgrade the firmware to the latest version.
- 3) Use SIIM66-62 to backup the FAX reception data from the HDD to a USB memory device. (If there is no FAX reception data, this procedure is not required.) (The FAX reception data are backed up in the PDF format. Supply the date to the user.)
- 4) Use SIM66-10 to clear the FAX and image send memory. (Ensure consistency between the HDD data and the image related memory.)

#### (4) Relation between the MFPC PWB LED status and errors

When the machine cannot be booted, check the LED status of the MFPC PWB to presume the error content and its cause.

##### <Process content and LED display>

LED status (Lighting)	Process operation content	Cause for halt during operation
○○○○	CPU initial setting	Reus ASIC trouble
○○○●	Memory adjustment	Memory and its peripheral circuit trouble
○○●○	Memory check	Memory and its peripheral circuit trouble
○○●●	—	—
○●○○	Program memory development	Memory-related trouble
○●●●	Interruption-related initialization	Reus ASIC trouble
○●●○	PCIe initialization	PCIe and its peripheral circuit trouble (SoC/ACRE, etc.)
○●●●	Basic device initialization	Reus ASIC trouble
●○○○	SD card initialization SATA initialization	Reus ASIC trouble SD card trouble HDD trouble
●○○●	OS initialization (1)	Reus ASIC trouble
●○●○	Timer enabling	Reus ASIC trouble
●○●●	Serial driver enabling I2C driver enabling	Reus ASIC trouble
●●○○	LCD initialization	Reus ASIC trouble
●●●○	Image process IP initialization	Reus ASIC trouble
●●●○	OS initialization (2)	Reus ASIC trouble
●●●●	Main process	Reus ASIC trouble

\* ● : LED ON / ○ : LED OFF

##### <When an error occurs>

LED status (Flashing)	Error content	Cause
○○○●	Nonsupport memory	Memory trouble
○○●○	Nonsupport memory (access speed)	Memory trouble
○○●●	Nonsupport memory controller	Memory trouble
○●○○	DDR-PHY setting error	Reus ASIC trouble
○●●○	Interruption handler process error	Reus ASIC trouble
●○○○	Memory check error	Memory trouble
●●●●	Memory combination error	Memory trouble

\* In case of an error, the LED's flash as shown in the above table.

\* ● : LED ON / ○ : LED OFF

○ ○ ○ ○ ●

LED No D25/D24/D23/D22  
3 / 2 / 1 / 0

## 2. JAM and troubleshooting

### A. JAM code list

#### (1) Main unit (18cpm/20cpm machine)

JAM code	JAM content	JAM detection method		Basic distance (A) [mm]	JAM margin distance (B) [mm]	JAM detection distance (A+B) [mm]
		JAM detection start trigger	JAM judgment condition			
TRAY1	Main cassette paper feed JAM (CPFD1 not-reached JAM)	CPUC1 ON	CPFD1 ON	103.4	65.0	168.4
CPFD1_N2	CPFD1 not-reached JAM (Main cassette 2 feed paper)	CPFD2 ON	CPFD1 ON	99.1	65.0	164.1
CPFD1_N3	CPFD1 not-reached JAM (Desk upper stage feed paper)	CPFD2 ON	CPFD1 ON	107.0	65.0	172.0
CPFD1_N4	CPFD1 not-reached JAM (Desk lower stage feed paper)	CPFD2 ON	CPFD1 ON	107.0	65.0	172.0
TRAY2	CPFD2 not-reached JAM (Main cassette 2 feed paper)	CPUC2 ON	CPFD2 ON	103.4	65.0	168.4
CPFD2_N3	CPFD2 not-reached JAM (Desk upper stage feed paper)	Reception of the paper feed start command from DESK (At position 45mm from the final roller of the DESK.)	CPFD2 ON	35.5	65.0	100.5
CPFD2_N4	CPFD2 not-reached JAM (Desk lower stage feed paper)	Reception of the paper feed start command from DESK (At position 45mm from the final roller of the DESK.)	CPFD2 ON	35.5	65.0	100.5
MFT	Manual feed tray paper feed JAM (PPD1 not-reached)	MPFS ON	PPD1 ON	83.2	65.0	148.2
PPD1_N1	PPD1 not-reached JAM (Cassette 1 feed paper)	CPFD1 ON	PPD1 ON	151.9	65.0	216.9
PPD1_N2	PPD1 not-reached JAM (Main cassette 2 feed paper)	CPFD1 ON	PPD1 ON	149.6	65.0	214.6
PPD1_N3	PPD1 not-reached JAM (Desk upper stage feed paper)	CPFD1 ON	PPD1 ON	149.6	65.0	214.6
PPD1_N4	PPD1 not-reached JAM (Desk lower stage feed paper)	CPFD1 ON	PPD1 ON	149.6	65.0	214.6
PPD1_NA	PPD1 not-reached JAM (ADU refeed paper)	APPD2 ON	PPD1 ON	135.7	65.0	200.7
PPD2_N1	PPD2 not-reached JAM (Main cassette feed paper)	CPFD1 ON	PPD2 ON	71.9	65.0	136.9
PPD2_N2	PPD2 not-reached JAM (Main cassette 2 feed paper)	CPFD1 ON	PPD2 ON	71.9	65.0	136.9
PPD2_N3	PPD2 not-reached JAM (Desk upper stage feed paper)	CPFD1 ON	PPD2 ON	71.9	65.0	136.9
PPD2_N4	PPD2 not-reached JAM (Desk lower stage feed paper)	CPFD1 ON	PPD2 ON	71.9	65.0	136.9
PPD2_NM	PPD2 not-reached JAM (Manual feed tray feed paper)	PPD1 ON	PPD2 ON	70.4	65.0	135.4
PPD2_NA	PPD2 not-reached JAM (ADU refeed paper)	PPD1 ON	PPD2 ON	70.4	65.0	135.4
POD1_N	POD1 not-reached JAM	RRM ON	POD1 ON	242.4	50.0	292.4
POD2_N	POD2 not-reached JAM	POD1 ON	POD2 ON	92.2	65.0	157.2
POD3_N	POD3 not-reached JAM	Reversing start	POD3 ON	53.7	65.0	118.7
APPD1_N	APPD1 not-reached JAM	Reversing start	APPD1 ON	39.3	65.0	104.3
APPD2_N	APPD2 not-reached JAM	APPD1 ON	APPD2 ON	226.3	65.0	291.3
CPFD1_S1	CPFD1 remaining JAM (Main cassette paper)	CPUC1 OFF	CPFD1 OFF	144.4	65.0	209.4
CPFD1_S2	CPFD1 remaining JAM (Main cassette 2 feed paper)	CPFD2 OFF	CPFD1 OFF	96.8	65.0	161.8
CPFD1_S3	CPFD1 remaining JAM (Desk upper stage feed paper)	CPFD2 OFF	CPFD1 OFF	107.0	65.0	172.0
CPFD1_S4	CPFD1 remaining JAM (Desk lower stage feed paper)	CPFD2 OFF	CPFD1 OFF	107.0	65.0	172.0
CPFD2_S2	CPFD2 remaining JAM (Main cassette 2 feed paper)	CPUC2 OFF	CPFD2 OFF	144.4	65.0	209.4
CPFD2_S3	CPFD2 remaining JAM (Desk upper stage feed paper)	Reception of the paper feed end command from DESK (The final roller position of DSEK)	CPFD2 OFF	89.2	65.0	154.2
CPFD2_S4	CPFD2 remaining JAM (Desk lower stage feed paper)	Reception of the paper feed end command from DESK (The final roller position of DSEK)	CPFD2 OFF	89.2	65.0	154.2

JAM code	JAM content	JAM detection method		Basic distance (A) [mm]	JAM margin distance (B) [mm]	JAM detection distance (A+B) [mm]
		JAM detection start trigger	JAM judgment condition			
PPD1_S1	PPD1 remaining JAM (Main cassette paper)	CPFD1 OFF	PPD1 OFF	149.9	65.0	214.9
PPD1_S2	PPD1 remaining JAM (Main cassette 2 feed paper)	CPFD1 OFF	PPD1 OFF	149.9	65.0	214.9
PPD1_S3	PPD1 remaining JAM (Desk upper stage feed paper)	CPFD1 OFF	PPD1 OFF	149.9	65.0	214.9
PPD1_S4	PPD1 remaining JAM (Desk lower stage feed paper)	CPFD1 OFF	PPD1 OFF	149.9	65.0	214.9
PPD1_SM	PPD1 remaining JAM (Manual feed tray feed paper)	PPD1 ON	PPD1 OFF	Sub scan size -9	65.0	Sub scan size -9+65
PPD1_SA	PPD1 remaining JAM (ADU refeed paper)	APPD2 OFF	PPD1 OFF	131.1	65.0	196.1
PPD2_S1	PPD2 remaining JAM (Main cassette feed paper)	PPD1 OFF	PPD2 OFF	62.9	65.0	127.9
PPD2_S2	PPD2 remaining JAM (Main cassette 2 feed paper)	PPD1 OFF	PPD2 OFF	62.9	65.0	127.9
PPD2_S3	PPD2 remaining JAM (Desk upper stage feed paper)	PPD1 OFF	PPD2 OFF	62.9	65.0	127.9
PPD2_S4	PPD2 remaining JAM (Desk lower stage feed paper)	PPD1 OFF	PPD2 OFF	62.9	65.0	127.9
PPD2_SM	PPD2 remaining JAM (Manual feed tray feed paper)	PPD1 OFF	PPD2 OFF	61.4	65.0	126.4
PPD2_SA	PPD2 remaining JAM (ADU refeed paper)	PPD1 OFF	PPD2 OFF	61.4	65.0	126.4
POD1_S	POD1 remaining JAM	PPD2 OFF	POD1 OFF	297.6	65.0	362.6
POD2_S	POD2 remaining JAM (When left paper exit)	POD1 OFF	POD2 OFF	90.2	65.0	155.2
	POD2 remaining JAM (When ADU reversing)	Reversing start	POD2 OFF after starting reversing	Sub scan size -60.6	65.0	Sub scan size -60.6 + 65
POD3_S	POD3 remaining JAM	POD2 OFF after starting reversing	POD3 OFF	68.9	65.0	133.9
APPD1_S	APPD1 remaining JAM	POD2 OFF after starting reversing	APPD1 OFF	111.0	65.0	176.0
APPD2_S	APPD2 remaining JAM	APPD1 OFF	APPD2 OFF	228.8	65.0	293.8
PPD2_PRI	PPD2 JAM (Image preparation wait time-out)	Transmission of the IMAGE_PREPARE command to ICU	Reception time-out of the END_IMAGE_PREPARE command from ICU (50 sec)	—	—	—
CPFD2_DESK	CPFD2 JAM (Desk communication abnormality detection)	Transmission of the preliminary paper feed request command to DESK	Reception time-out of the preliminary paper feed start command from DESK (30 sec)	—	—	—
		Reception of the preliminary paper feed start command from DESK	Reception time-out of the preliminary paper feed end command from DESK (30 sec)	—	—	—
		Transmission of the paper feed request command to DESK	Reception time-out of the paper feed start command from DESK (30 sec)	—	—	—
		Reception of the paper feed start command from DESK	Reception time-out of the paper feed end command from DESK (30 sec)	—	—	—
PPD2_FIN	PPD2 JAM (Finisher communication abnormality detection)	Transmission of the paper attribute data command to FINISHER	Reception time-out of the paper interval data command from FINISHER (30 sec)	—	—	—

## (2) Main unit (23cpm machine)

JAM code	JAM content	JAM detection method		Basic distance (A) [mm]	JAM margin distance (B) [mm]	JAM detection distance (A+B) [mm]
		JAM detection start trigger	JAM judgment condition			
TRAY1	Main cassette paper feed JAM (CPFD1 not-reached JAM)	CPUC1 ON	CPFD1 ON	103.4	65.0	168.4
CPFD1_N2	CPFD1 not-reached JAM (Main cassette 2 feed paper)	CPFD2 ON	CPFD1 ON	99.1	65.0	164.1
CPFD1_N3	CPFD1 not-reached JAM (Desk upper stage feed paper)	CPFD2 ON	CPFD1 ON	107.0	65.0	172.0
CPFD1_N4	CPFD1 not-reached JAM (Desk lower stage feed paper)	CPFD2 ON	CPFD1 ON	107.0	65.0	172.0

JAM code	JAM content	JAM detection method		Basic distance (A) [mm]	JAM margin distance (B) [mm]	JAM detection distance (A+B) [mm]
		JAM detection start trigger	JAM judgment condition			
TRAY2	CPFD2 not-reached JAM (Main cassette 2 feed paper)	CPUC2 ON	CPFD2 ON	103.4	65.0	168.4
CPFD2_N3	CPFD2 not-reached JAM (Desk upper stage feed paper)	Reception of the paper feed start command from DESK (At position 45mm from the final roller of the DESK.)	CPFD2 ON	35.5	65.0	100.5
CPFD2_N4	CPFD2 not-reached JAM (Desk lower stage feed paper)	Reception of the paper feed start command from DESK (At position 45mm from the final roller of the DESK.)	CPFD2 ON	35.5	65.0	100.5
MFT	Manual feed tray paper feed JAM (PPD1 not-reached)	MPFS ON	PPD1 ON	83.2	65.0	148.2
PPD1_N1	PPD1 not-reached JAM (Cassette 1 feed paper)	CPFD1 ON	PPD1 ON	151.9	65.0	216.9
PPD1_N2	PPD1 not-reached JAM (Main cassette 2 feed paper)	CPFD1 ON	PPD1 ON	149.6	65.0	214.6
PPD1_N3	PPD1 not-reached JAM (Desk upper stage feed paper)	CPFD1 ON	PPD1 ON	149.6	65.0	214.6
PPD1_N4	PPD1 not-reached JAM (Desk lower stage feed paper)	CPFD1 ON	PPD1 ON	149.6	65.0	214.6
PPD1_NA	PPD1 not-reached JAM (ADU refeed paper)	APPD2 ON	PPD1 ON	135.7	65.0	200.7
PPD2_N1	PPD2 not-reached JAM (Main cassette feed paper)	CPFD1 ON	PPD2 ON	71.9	65.0	136.9
PPD2_N2	PPD2 not-reached JAM (Main cassette 2 feed paper)	CPFD1 ON	PPD2 ON	71.9	65.0	136.9
PPD2_N3	PPD2 not-reached JAM (Desk upper stage feed paper)	CPFD1 ON	PPD2 ON	71.9	65.0	136.9
PPD2_N4	PPD2 not-reached JAM (Desk lower stage feed paper)	CPFD1 ON	PPD2 ON	71.9	65.0	136.9
PPD2_NM	PPD2 not-reached JAM (Manual feed tray feed paper)	PPD1 ON	PPD2 ON	70.4	65.0	135.4
PPD2_NA	PPD2 not-reached JAM (ADU refeed paper)	PPD1 ON	PPD2 ON	70.4	65.0	135.4
POD1_N	POD1 not-reached JAM	RRM ON	POD1 ON	242.4	50.0	292.4
POD2_N	POD2 not-reached JAM	POD1 ON	POD2 ON	92.2	65.0	157.2
POD3_N	POD3 not-reached JAM	Reversing start	POD3 ON	53.7	65.0	118.7
APPD1_N	APPD1 not-reached JAM	Reversing start	APPD1 ON	39.3	65.0	104.3
APPD2_N	APPD2 not-reached JAM	APPD1 ON	APPD2 ON	226.3	65.0	291.3
CPFD1_S1	CPFD1 remaining JAM (Main cassette paper)	CPUC1 OFF	CPFD1 OFF	144.4	65.0	209.4
CPFD1_S2	CPFD1 remaining JAM (Main cassette 2 feed paper)	CPFD2 OFF	CPFD1 OFF	96.8	65.0	161.8
CPFD1_S3	CPFD1 remaining JAM (Desk upper stage feed paper)	CPFD2 OFF	CPFD1 OFF	107.0	65.0	172.0
CPFD1_S4	CPFD1 remaining JAM (Desk lower stage feed paper)	CPFD2 OFF	CPFD1 OFF	107.0	65.0	172.0
CPFD2_S2	CPFD2 remaining JAM (Main cassette 2 feed paper)	CPUC2 OFF	CPFD2 OFF	144.4	65.0	209.4
CPFD2_S3	CPFD2 remaining JAM (Desk upper stage feed paper)	Reception of the paper feed end command from DESK (The final roller position of DSEK)	CPFD2 OFF	89.2	65.0	154.2
CPFD2_S4	CPFD2 remaining JAM (Desk lower stage feed paper)	Reception of the paper feed end command from DESK (The final roller position of DSEK)	CPFD2 OFF	89.2	65.0	154.2
PPD1_S1	PPD1 remaining JAM (Main cassette paper)	CPFD1 OFF	PPD1 OFF	149.9	65.0	214.9
PPD1_S2	PPD1 remaining JAM (Main cassette 2 feed paper)	CPFD1 OFF	PPD1 OFF	149.9	65.0	214.9
PPD1_S3	PPD1 remaining JAM (Desk upper stage feed paper)	CPFD1 OFF	PPD1 OFF	149.9	65.0	214.9
PPD1_S4	PPD1 remaining JAM (Desk lower stage feed paper)	CPFD1 OFF	PPD1 OFF	149.9	65.0	214.9
PPD1_SM	PPD1 remaining JAM (Manual feed tray feed paper)	PPD1 ON	PPD1 OFF	Sub scan size -9	65.0	Sub scan size -9+65
PPD1_SA	PPD1 remaining JAM (ADU refeed paper)	APPD2 OFF	PPD1 OFF	131.1	65.0	196.1

JAM code	JAM content	JAM detection method		Basic distance (A) [mm]	JAM margin distance (B) [mm]	JAM detection distance (A+B) [mm]
		JAM detection start trigger	JAM judgment condition			
PPD2_S1	PPD2 remaining JAM (Main cassette feed paper)	PPD1 OFF	PPD2 OFF	62.9	65.0	127.9
PPD2_S2	PPD2 remaining JAM (Main cassette 2 feed paper)	PPD1 OFF	PPD2 OFF	62.9	65.0	127.9
PPD2_S3	PPD2 remaining JAM (Desk upper stage feed paper)	PPD1 OFF	PPD2 OFF	62.9	65.0	127.9
PPD2_S4	PPD2 remaining JAM (Desk lower stage feed paper)	PPD1 OFF	PPD2 OFF	62.9	65.0	127.9
PPD2_SM	PPD2 remaining JAM (Manual feed tray feed paper)	PPD1 OFF	PPD2 OFF	61.4	65.0	126.4
PPD2_SA	PPD2 remaining JAM (ADU refeed paper)	PPD1 OFF	PPD2 OFF	61.4	65.0	126.4
POD1_S	POD1 remaining JAM	PPD2 OFF	POD1 OFF	297.6	65.0	362.6
POD2_S	POD2 remaining JAM (When left paper exit)	POD1 OFF	POD2 OFF	90.2	65.0	155.2
	POD2 remaining JAM (When ADU reversing)	Reversing start	POD2 OFF after starting reversing	Sub scan size -60.6	65.0	Sub scan size -60.6 + 65
POD3_S	POD3 remaining JAM	POD2 OFF after starting reversing	POD3 OFF	68.9	65.0	133.9
APPD1_S	APPD1 remaining JAM	POD2 OFF after starting reversing	APPD1 OFF	111.0	65.0	176.0
APPD2_S	APPD2 remaining JAM	APPD1 OFF	APPD2 OFF	228.8	65.0	293.8
PPD2_PRI	PPD2 JAM (Image preparation wait time-out)	Transmission of the IMAGE_PREPARE command to ICU	Reception time-out of the END_IMAGE_PREPARE command from ICU (50 sec)	—	—	—
CPFD2_DESK	CPFD2 JAM (Desk communication abnormality detection)	Transmission of the preliminary paper feed request command to DESK	Reception time-out of the preliminary paper feed start command from DESK (30 sec)	—	—	—
		Reception of the preliminary paper feed start command from DESK	Reception time-out of the preliminary paper feed end command from DESK (30 sec)	—	—	—
		Transmission of the paper feed request command to DESK	Reception time-out of the paper feed start command from DESK (30 sec)	—	—	—
		Reception of the paper feed start command from DESK	Reception time-out of the paper feed end command from DESK (30 sec)	—	—	—
PPD2_FIN	PPD2 JAM (Finisher communication abnormality detection)	Transmission of the paper attribute data command to FINISHER	Reception time-out of the paper interval data command from FINISHER (30 sec)	—	—	—

### (3) 26cpm/31cpm machine

JAM code	JAM content	JAM detection method		Basic distance (A) [mm]	JAM margin distance (B) [mm]	JAM detection distance (A+B) [mm]
		JAM detection start trigger	JAM judgment condition			
TRAY1	Main cassette paper feed JAM (CPFD1 not-reached JAM)	CPUC1 ON	CPFD1 ON	103.4	65.0	168.4
CPFD1_N2	CPFD1 not-reached JAM (Main cassette 2 feed paper)	CPFD2 ON	CPFD1 ON	99.1	65.0	164.1
CPFD1_N3	CPFD1 not-reached JAM (Desk upper stage feed paper)	CPFD2 ON	CPFD1 ON	107.0	65.0	172.0
CPFD1_N4	CPFD1 not-reached JAM (Desk lower stage feed paper)	CPFD2 ON	CPFD1 ON	107.0	65.0	172.0
TRAY2	CPFD2 not-reached JAM (Main cassette 2 feed paper)	CPUC2 ON	CPFD2 ON	103.4	65.0	168.4
CPFD2_N3	CPFD2 not-reached JAM (Desk upper stage feed paper)	Reception of the paper feed start command from DESK (At position 45mm from the final roller of the DESK.)	CPFD2 ON	35.5	65.0	100.5
CPFD2_N4	CPFD2 not-reached JAM (Desk lower stage feed paper)	Reception of the paper feed start command from DESK (At position 45mm from the final roller of the DESK.)	CPFD2 ON	35.5	65.0	100.5
MFT	Manual feed tray paper feed JAM (PPD1 not-reached)	MPFS ON	PPD1 ON	83.2	65.0	148.2
PPD1_N1	PPD1 not-reached JAM (Cassette 1 feed paper)	CPFD1 ON	PPD1 ON	151.9	65.0	216.9

JAM code	JAM content	JAM detection method		Basic distance (A) [mm]	JAM margin distance (B) [mm]	JAM detection distance (A+B) [mm]
		JAM detection start trigger	JAM judgment condition			
PPD1_N2	PPD1 not-reached JAM (Main cassette 2 feed paper)	CPFD1 ON	PPD1 ON	149.6	65.0	214.6
PPD1_N3	PPD1 not-reached JAM (Desk upper stage feed paper)	CPFD1 ON	PPD1 ON	149.6	65.0	214.6
PPD1_N4	PPD1 not-reached JAM (Desk lower stage feed paper)	CPFD1 ON	PPD1 ON	149.6	65.0	214.6
PPD1_NA	PPD1 not-reached JAM (ADU refeed paper)	APPD2 ON	PPD1 ON	135.7	65.0	200.7
PPD1_NL	PPD1 not-reached JAM (LCC feed paper)	Reception of the paper feed start command from LCC (Extension amount 19mm position)	PPD1 ON	141.7	65.0	206.7
PPD2_N1	PPD2 not-reached JAM (Main cassette feed paper)	CPFD1 ON	PPD2 ON	71.9	65.0	136.9
PPD2_N2	PPD2 not-reached JAM (Main cassette 2 feed paper)	CPFD1 ON	PPD2 ON	71.9	65.0	136.9
PPD2_N3	PPD2 not-reached JAM (Desk upper stage feed paper)	CPFD1 ON	PPD2 ON	71.9	65.0	136.9
PPD2_N4	PPD2 not-reached JAM (Desk lower stage feed paper)	CPFD1 ON	PPD2 ON	71.9	65.0	136.9
PPD2_NM	PPD2 not-reached JAM (Manual feed tray feed paper)	PPD1 ON	PPD2 ON	70.4	65.0	135.4
PPD2_NA	PPD2 not-reached JAM (ADU refeed paper)	PPD1 ON	PPD2 ON	70.4	65.0	135.4
PPD2_NL	PPD2 not-reached JAM (LCC feed paper)	PPD1 ON	PPD2 ON	71.9	65.0	136.9
POD1_N	POD1 not-reached JAM	RRM ON	POD1 ON	242.4	50.0	292.4
POD2_N	POD2 not-reached JAM	POD1 ON	POD2 ON	92.2	65.0	157.2
POD3_N	POD3 not-reached JAM	Reversing start	POD3 ON	53.7	65.0	118.7
APPD1_N	APPD1 not-reached JAM	Reversing start	APPD1 ON	39.3	65.0	104.3
APPD2_N	APPD2 not-reached JAM	APPD1 ON	APPD2 ON	226.3	65.0	291.3
CPFD1_S1	CPFD1 remaining JAM (Main cassette paper)	CPUC1 OFF	CPFD1 OFF	144.4	65.0	209.4
CPFD1_S2	CPFD1 remaining JAM (Main cassette 2 feed paper)	CPFD2 OFF	CPFD1 OFF	96.8	65.0	161.8
CPFD1_S3	CPFD1 remaining JAM (Desk upper stage feed paper)	CPFD2 OFF	CPFD1 OFF	107.0	65.0	172.0
CPFD1_S4	CPFD1 remaining JAM (Desk lower stage feed paper)	CPFD2 OFF	CPFD1 OFF	107.0	65.0	172.0
CPFD2_S2	CPFD2 remaining JAM (Main cassette 2 feed paper)	CPUC2 OFF	CPFD2 OFF	144.4	65.0	209.4
CPFD2_S3	CPFD2 remaining JAM (Desk upper stage feed paper)	Reception of the paper feed end command from DESK (The final roller position of DSEK)	CPFD2 OFF	89.2	65.0	154.2
CPFD2_S4	CPFD2 remaining JAM (Desk lower stage feed paper)	Reception of the paper feed end command from DESK (The final roller position of DSEK)	CPFD2 OFF	89.2	65.0	154.2
PPD1_S1	PPD1 remaining JAM (Main cassette paper)	CPFD1 OFF	PPD1 OFF	149.9	65.0	214.9
PPD1_S2	PPD1 remaining JAM (Main cassette 2 feed paper)	CPFD1 OFF	PPD1 OFF	149.9	65.0	214.9
PPD1_S3	PPD1 remaining JAM (Desk upper stage feed paper)	CPFD1 OFF	PPD1 OFF	149.9	65.0	214.9
PPD1_S4	PPD1 remaining JAM (Desk lower stage feed paper)	CPFD1 OFF	PPD1 OFF	149.9	65.0	214.9
PPD1_SM	PPD1 remaining JAM (Manual feed tray feed paper)	PPD1 ON	PPD1 OFF	Sub scan size -9	65.0	Sub scan size -9 + 65
PPD1_SA	PPD1 remaining JAM (ADU refeed paper)	APPD2 OFF	PPD1 OFF	131.1	65.0	196.1
PPD1_SL	PPD1 remaining JAM (LCC refeed paper)	Reception of the paper feed end command from LCC (LPFD OFF)	PPD1 OFF	179.1	65.0	244.1
PPD2_S1	PPD2 remaining JAM (Main cassette feed paper)	PPD1 OFF	PPD2 OFF	62.9	65.0	127.9
PPD2_S2	PPD2 remaining JAM (Main cassette 2 feed paper)	PPD1 OFF	PPD2 OFF	62.9	65.0	127.9
PPD2_S3	PPD2 remaining JAM (Desk upper stage feed paper)	PPD1 OFF	PPD2 OFF	62.9	65.0	127.9



JAM code	JAM content	JAM detection method		Basic distance (A) [mm]	JAM margin distance (B) [mm]	JAM detection distance (A+B) [mm]
		JAM detection start trigger	JAM judgment condition			
PPD2_S4	PPD2 remaining JAM (Desk lower stage feed paper)	PPD1 OFF	PPD2 OFF	62.9	65.0	127.9
PPD2_SM	PPD2 remaining JAM (Manual feed tray feed paper)	PPD1 OFF	PPD2 OFF	61.4	65.0	126.4
PPD2_SA	PPD2 remaining JAM (ADU refeed paper)	PPD1 OFF	PPD2 OFF	61.4	65.0	126.4
PPD2_SL	PPD2 remaining JAM (LCC feed paper)	PPD1 OFF	PPD2 OFF	62.9	65.0	127.9
POD1_S	POD1 remaining JAM	PPD2 OFF	POD1 OFF	297.6	65.0	362.6
POD2_S	POD2 remaining JAM (When left paper exit)	POD1 OFF	POD2 OFF	90.2	65.0	155.2
	POD2 remaining JAM (When ADU reversing)	Reversing start	POD2 OFF after starting reversing	Sub scan size -60.6	65.0	Sub scan size -60.6 + 65
POD3_S	POD3 remaining JAM	POD2 OFF after starting reversing	POD3 OFF	68.9	65.0	133.9
APPD1_S	APPD1 remaining JAM	POD2 OFF after starting reversing	APPD1 OFF	111.0	65.0	176.0
APPD2_S	APPD2 remaining JAM	APPD1 OFF	APPD2 OFF	228.8	65.0	293.8
PPD2_PRI	PPD2 JAM (Image preparation wait time-out)	Transmission of the IMAGE_PREPARE command to ICU	Reception time-out of the END_IMAGE_PREPARE command from ICU (50 sec)	—	—	—
CPFD2_DESK	CPFD2 JAM (Desk communication abnormality detection)	Transmission of the preliminary paper feed request command to DESK	Reception time-out of the preliminary paper feed start command from DESK (30 sec)	—	—	—
		Reception of the preliminary paper feed start command from DESK	Reception time-out of the preliminary paper feed end command from DESK (30 sec)	—	—	—
		Transmission of the paper feed request command to DESK	Reception time-out of the paper feed start command from DESK (30 sec)	—	—	—
		Reception of the paper feed start command from DESK	Reception time-out of the paper feed end command from DESK (30 sec)	—	—	—
PPD1_LCC	PPD1 JAM (LCC communication abnormality detection)	Transmission of the preliminary paper feed request command to LCC	Reception time-out of the preliminary paper feed start command from LCC (30 sec)	—	—	—
		Reception of the preliminary paper feed start command from LCC	Reception time-out of the preliminary paper feed end command from LCC (30 sec)	—	—	—
		Transmission of the paper feed request command to LCC	Reception time-out of the paper feed start command from LCC (30 sec)	—	—	—
		Reception of the paper feed start command from LCC	Reception time-out of the paper feed end command from LCC (30 sec)	—	—	—
PPD2_FIN	PPD2 JAM (Finisher communication abnormality detection)	Transmission of the paper attribute data command to FINISHER	Reception time-out of the paper interval data command from FINISHER (30 sec)	—	—	—

#### (4) 36cpm machine

JAM code	JAM content	JAM detection method		Basic distance (A) [mm]	JAM margin distance (B) [mm]	JAM detection distance (A+B) [mm]
		JAM detection start trigger	JAM judgment condition			
TRAY1	Main cassette paper feed JAM (CPFD1 not-reached JAM)	CPUC1 ON	CPFD1 ON	103.4	65.0	168.4
CPFD1_N2	CPFD1 not-reached JAM (Main cassette 2 feed paper)	CPFD2 ON	CPFD1 ON	99.1	65.0	164.1
CPFD1_N3	CPFD1 not-reached JAM (Desk upper stage feed paper)	CPFD2 ON	CPFD1 ON	107.0	65.0	172.0
CPFD1_N4	CPFD1 not-reached JAM (Desk lower stage feed paper)	CPFD2 ON	CPFD1 ON	107.0	65.0	172.0
TRAY2	CPFD2 not-reached JAM (Main cassette 2 feed paper)	CPUC2 ON	CPFD2 ON	103.4	65.0	168.4
CPFD2_N3	CPFD2 not-reached JAM (Desk upper stage feed paper)	Reception of the paper feed start command from DESK (At position 45mm from the final roller of the DESK.)	CPFD2 ON	35.5	65.0	100.5

JAM code	JAM content	JAM detection method		Basic distance (A) [mm]	JAM margin distance (B) [mm]	JAM detection distance (A+B) [mm]
		JAM detection start trigger	JAM judgment condition			
CPFD2_N4	CPFD2 not-reached JAM (Desk lower stage feed paper)	Reception of the paper feed start command from DESK (At position 45mm from the final roller of the DESK.)	CPFD2 ON	35.5	65.0	100.5
MFT	Manual feed tray paper feed JAM (PPD1 not-reached)	MPFS ON	PPD1 ON	113.2	65.0	178.2
PPD1_N1	PPD1 not-reached JAM (Cassette 1 feed paper)	CPFD1 ON	PPD1 ON	151.9	65.0	216.9
PPD1_N2	PPD1 not-reached JAM (Main cassette 2 feed paper)	CPFD1 ON	PPD1 ON	149.6	65.0	214.6
PPD1_N3	PPD1 not-reached JAM (Desk upper stage feed paper)	CPFD1 ON	PPD1 ON	149.6	65.0	214.6
PPD1_N4	PPD1 not-reached JAM (Desk lower stage feed paper)	CPFD1 ON	PPD1 ON	149.6	65.0	214.6
PPD1_NA	PPD1 not-reached JAM (ADU refeed paper)	APPD2 ON	PPD1 ON	133.3	65.0	198.3
PPD1_NL	PPD1 not-reached JAM (LCC feed paper)	Reception of the paper feed start command from LCC (Extension amount 19mm position)	PPD1 ON	141.7	65.0	206.7
PPD2_N1	PPD2 not-reached JAM (Main cassette feed paper)	CPFD1 ON	PPD2 ON	71.9	65.0	136.9
PPD2_N2	PPD2 not-reached JAM (Main cassette 2 feed paper)	CPFD1 ON	PPD2 ON	71.9	65.0	136.9
PPD2_N3	PPD2 not-reached JAM (Desk upper stage feed paper)	CPFD1 ON	PPD2 ON	71.9	65.0	136.9
PPD2_N4	PPD2 not-reached JAM (Desk lower stage feed paper)	CPFD1 ON	PPD2 ON	71.9	65.0	136.9
PPD2_NM	PPD2 not-reached JAM (Manual feed tray feed paper)	PPD1 ON	PPD2 ON	70.4	65.0	135.4
PPD2_NA	PPD2 not-reached JAM (ADU refeed paper)	PPD1 ON	PPD2 ON	70.4	65.0	135.4
PPD2_NL	PPD2 not-reached JAM (LCC feed paper)	PPD1 ON	PPD2 ON	71.9	65.0	136.9
POD1_N	POD1 not-reached JAM	RRM ON	POD1 ON	242.4	50.0	292.4
POD2_N	POD2 not-reached JAM	POD1 ON	POD2 ON	92.2	65.0	157.2
POD3_N	POD3 not-reached JAM	Reversing start	POD3 ON	89.5	65.0	154.5
APPD1_N	APPD1 not-reached JAM	Reversing start	APPD1 ON	133.4	65.0	198.4
APPD2_N	APPD2 not-reached JAM	APPD1 ON	APPD2 ON	244.0	65.0	309.0
CPFD1_S1	CPFD1 remaining JAM (Main cassette paper)	CPUC1 OFF	CPFD1 OFF	144.4	65.0	209.4
CPFD1_S2	CPFD1 remaining JAM (Main cassette 2 feed paper)	CPFD2 OFF	CPFD1 OFF	96.8	65.0	161.8
CPFD1_S3	CPFD1 remaining JAM (Desk upper stage feed paper)	CPFD2 OFF	CPFD1 OFF	107.0	65.0	172.0
CPFD1_S4	CPFD1 remaining JAM (Desk lower stage feed paper)	CPFD2 OFF	CPFD1 OFF	107.0	65.0	172.0
CPFD2_S2	CPFD2 remaining JAM (Main cassette 2 feed paper)	CPUC2 OFF	CPFD2 OFF	144.4	65.0	209.4
CPFD2_S3	CPFD2 remaining JAM (Desk upper stage feed paper)	Reception of the paper feed end command from DESK (The final roller position of DSEK)	CPFD2 OFF	89.2	65.0	154.2
CPFD2_S4	CPFD2 remaining JAM (Desk lower stage feed paper)	Reception of the paper feed end command from DESK (The final roller position of DSEK)	CPFD2 OFF	89.2	65.0	154.2
PPD1_S1	PPD1 remaining JAM (Main cassette paper)	CPFD1 OFF	PPD1 OFF	149.9	65.0	214.9
PPD1_S2	PPD1 remaining JAM (Main cassette 2 feed paper)	CPFD1 OFF	PPD1 OFF	149.9	65.0	214.9
PPD1_S3	PPD1 remaining JAM (Desk upper stage feed paper)	CPFD1 OFF	PPD1 OFF	149.9	65.0	214.9
PPD1_S4	PPD1 remaining JAM (Desk lower stage feed paper)	CPFD1 OFF	PPD1 OFF	149.9	65.0	214.9
PPD1_SM	PPD1 remaining JAM (Manual feed tray feed paper)	PPD1 ON	PPD1 OFF	Sub scan size -9	65.0	Sub scan size -9 + 65
PPD1_SA	PPD1 remaining JAM (ADU refeed paper)	APPD2 OFF	PPD1 OFF	190.8	65.0	255.8

JAM code	JAM content	JAM detection method		Basic distance (A) [mm]	JAM margin distance (B) [mm]	JAM detection distance (A+B) [mm]
		JAM detection start trigger	JAM judgment condition			
PPD1_SL	PPD1 remaining JAM (LCC refeed paper)	Reception of the paper feed end command from LCC (LPFD OFF)	PPD1 OFF	179.1	65.0	244.1
PPD2_S1	PPD2 remaining JAM (Main cassette feed paper)	PPD1 OFF	PPD2 OFF	62.9	65.0	127.9
PPD2_S2	PPD2 remaining JAM (Main cassette 2 feed paper)	PPD1 OFF	PPD2 OFF	62.9	65.0	127.9
PPD2_S3	PPD2 remaining JAM (Desk upper stage feed paper)	PPD1 OFF	PPD2 OFF	62.9	65.0	127.9
PPD2_S4	PPD2 remaining JAM (Desk lower stage feed paper)	PPD1 OFF	PPD2 OFF	62.9	65.0	127.9
PPD2_SM	PPD2 remaining JAM (Manual feed tray feed paper)	PPD1 OFF	PPD2 OFF	61.4	65.0	126.4
PPD2_SA	PPD2 remaining JAM (ADU refeed paper)	PPD1 OFF	PPD2 OFF	61.4	65.0	126.4
PPD2_SL	PPD2 remaining JAM (LCC feed paper)	PPD1 OFF	PPD2 OFF	62.9	65.0	127.9
POD1_S	POD1 remaining JAM	PPD2 OFF	POD1 OFF	297.6	65.0	362.6
POD2_S	POD2 remaining JAM (When left paper exit)	POD1 OFF	POD2 OFF	90.2	65.0	155.2
	POD2 remaining JAM (When ADU reversing)	Reversing start	POD2 OFF after starting reversing	Sub scan size -9.4	65.0	Sub scan size -9.4 + 65
POD3_S	POD3 remaining JAM	POD2 OFF after starting reversing	POD3 OFF	104.9	65.0	169.9
APPD1_S	APPD1 remaining JAM	POD2 OFF after starting reversing	APPD1 OFF	146.7	65.0	211.7
APPD2_S	APPD2 remaining JAM	APPD1 OFF	APPD2 OFF	251.6	65.0	316.6
PPD2_PRI	PPD2 JAM (Image preparation wait time-out)	Transmission of the IMAGE_PREPARE command to ICU	Reception time-out of the END_IMAGE_PREPARE command from ICU (50 sec)	—	—	—
CPFD2_DESK	CPFD2 JAM (Desk communication abnormality detection)	Transmission of the preliminary paper feed request command to DESK	Reception time-out of the preliminary paper feed start command from DESK (30 sec)	—	—	—
		Reception of the preliminary paper feed start command from DESK	Reception time-out of the preliminary paper feed end command from DESK (30 sec)	—	—	—
		Transmission of the paper feed request command to DESK	Reception time-out of the paper feed start command from DESK (30 sec)	—	—	—
		Reception of the paper feed start command from DESK	Reception time-out of the paper feed end command from DESK (30 sec)	—	—	—
PPD1_LCC	PPD1 JAM (LCC communication abnormality detection)	Transmission of the preliminary paper feed request command to LCC	Reception time-out of the preliminary paper feed start command from LCC (30 sec)	—	—	—
		Reception of the preliminary paper feed start command from LCC	Reception time-out of the preliminary paper feed end command from LCC (30 sec)	—	—	—
		Transmission of the paper feed request command to LCC	Reception time-out of the paper feed start command from LCC (30 sec)	—	—	—
		Reception of the paper feed start command from LCC	Reception time-out of the paper feed end command from LCC (30 sec)	—	—	—
PPD2_FIN	PPD2 JAM (Finisher communication abnormality detection)	Transmission of the paper attribute data command to FINISHER	Reception time-out of the paper interval data command from FINISHER (30 sec)	—	—	—

(5) RSPF

JAM code	JAM content	JAM detection method		Basic distance (A) [mm]	JAM margin distance (B) [mm]	JAM detection distance (A+B) [mm]
		JAM detection start trigger	JAM judgment condition			
SPPD1_N	SPPD1 not-reached JAM	Paper feed start (When the document width is more than B5 size.)	SPPD1 ON	51.5	450.0	501.5
SPPD2_N	SPPD2 not-reached JAM	Paper feed start (When the document width is less than B5 size.)	SPPD2 ON	90.2	450.0	540.2
		SPPD1 ON (When the document width is more than B5 size.)	SPPD2 ON	38.7	50.0	88.7
SPPD3_N	SPPD3 not-reached JAM	Restart at the temporal stop position	SPPD3 ON	23.7	50.0	73.7
SPPD4_N	SPPD4 not-reached JAM	SPPD3 ON	SPPD4 ON	149.1	50.0	199.1
SPPD2_NR	SPPD2 reverse not-reached JAM	Reversing start	SPPD2 ON	85.5	50.0	135.5
SPPD1_S	SPPD1 remaining JAM	SPPD1 ON (When the document width is more than B5 size.)	SPPD1 OFF	Normal mode: 431.8mm Long size mode: 1000mm/ 800mm (18cpm/ 20cpm/23cpm model 600dpi mode)	50.0	Normal mode: 481.8mm Long size mode: 1050mm/ 850mm (18cpm/ 20cpm/23cpm model 600dpi mode)
SPPD2_S	SPPD2 remaining JAM	SPPD2 ON (When the document width is less than B5 size.)	SPPD2 OFF	Normal mode: 431.8mm Long size mode: 1000mm/ 800mm (18cpm/ 20cpm/23cpm model 600dpi mode)	50.0	Normal mode: 481.8mm Long size mode: 1050mm/ 850mm (18cpm/ 20cpm/23cpm model 600dpi mode)
		SPPD1 OFF (When the document width is more than B5 size.)	SPPD2 OFF	37.8	50.0	87.8
SPPD3_S	SPPD3 remaining JAM	SPPD2 OFF	SPPD3 OFF	68.8	50.0	118.8
SPPD4_S	SPPD4 remaining JAM	SPPD3 OFF	SPPD4 OFF	153.3	50.0	203.3
SPPD2_SR	SPPD2 reverse remaining JAM	SPPD4 OFF	SPPD2 OFF	100.9	50.0	150.9
SPSD_SCN	Exposure start notification timer end	Arrival at temporal stop position	Exposure start command from ICU to SCU no reception time-out (120 sec)	—	—	—
P_SHORT	Short size JAM	SPPD3 ON	When the document length is less than 120.0mm.	—	—	—
SDFS_S	Paper JAM	Start of the light quantity correction between papers	When canceling of the light quantity correction between papers does not make it in time.	—	—	—
ICU_REQ	ICU factor stop JAM	—	Stop by a job stop request command from ICU to SCU	—	—	—
STOP_JAM	Emergency stop JAM	—	Trouble mode transition request from ICU to SCU Emergency stop by a command	—	—	—

(6) Desk

JAM code	JAM content	JAM detection method	
		JAM detection start trigger	JAM judgment condition
TRAY3	Cassette 3 (Desk 1) paper feed JAM	D1PFC ON (Paper feed start)	D1PPD does not turn ON within the specified time.
DPFD1_N4	DPFD1 not-reached JAM (Desk 2 feed paper)	D2PPD ON	D1PPD does not turn ON within the specified time.
DPFD1_S3	DPFD1 remaining JAM (Desk 1 feed paper)	D1PPD ON	D1PPD does not turn OFF within the specified time.
DPFD1_S4	DPFD1 remaining JAM (Desk 2 feed paper)	D2PPD OFF	D1PPD does not turn OFF within the specified time.
DPFD2_S4	DPFD2 remaining JAM (Desk 2 feed paper)	D2PPD ON	D2PPD does not turn OFF within the specified time.
TRAY4	Cassette 4 (Desk 2) paper feed JAM	D2PFC ON (Paper feed start)	D2PPD does not turn ON within the specified time.

## (7) LCC

JAM code	JAM content	JAM detection method	
		JAM detection start trigger	JAM judgment condition
LCC	Side LCC paper feed JAM (LPFD not-reached)	LPFC ON (paper feed start)	LPFD does not turn ON within the specified time.
LPFD_SL	LPFD remaining JAM (Side LCC feed paper)	LPFD ON	LPFD does not turn OFF within the specified time.

## (8) Inner finisher

JAM code	JAM content	JAM detection method		Basic distance (A) [mm]	JAM margin distance (B) [mm]	JAM detection distance (A+B) [mm]
		JAM detection start trigger	JAM judgment condition			
FPPD1_N	Finisher inlet port not-reached JAM	Machine paper exit command reception	FPPD1 does not turn ON within the specified time.	134.602 [mm]	400 [mm]	534.602 [mm]
FPPD1_S	Finisher inlet port remaining JAM (When Long-size paper support OFF)	FPPD1 ON	FPPD1 does not turn OFF within the specified time.	464.803 [mm]	50 [mm]	514.803 [mm]
	Finisher inlet port remaining JAM (When Long-size paper support ON)	FPPD1 ON	FPPD1 does not turn OFF within the specified time.	1207.803 [mm]	50 [mm]	1257.803 [mm]
FPDD_S	Bundle exit remaining JAM	Driving the bundle exit roller is started.	FSTPD does not turn OFF within the specified time.	133.1 [mm]	13.66 [mm]	146.76 [mm]
FIN_TIME	Finisher paper early reaching JAM	FPPD1 ON by the prior paper detection	FPPD1 of the next paper turns ON at the timing earlier than the specified paper interval.	Specified paper interval time	30 [mm]	(Paper interval time) - (Paper transport time of 30 [mm]) [msec]
FSTPD_S	Finisher paper exit remaining JAM	Driving the paper exit roller in the straight mode is started.	FSTPD does not turn OFF within the specified time.	96.76 [mm]	50 [mm]	146.76 [mm]
FSTPLJ	Staple JAM	FSHPS OFF after FSM ON	FSHPS does not turn ON within the specified time.	350 [msec]	250 [msec]	600 [msec]

## (9) Saddle finisher

JAM code	JAM content	JAM detection method		Basic distance (A) [mm]	JAM margin distance (B) [mm]	JAM detection distance (A+B) [mm]
		JAM detection start trigger	JAM judgment condition			
PDPPD1_N	Interface inlet port not-reached JAM	Machine paper exit command reception	PDPPD1 does not turn ON within the specified time.	79.6 [mm]	238.8 [mm]	318.4 [mm]
PDPPD1_S	Interface inlet port remaining JAM	PDPPD1 ON	PDPPD1 does not turn OFF within the specified time.	(Paper length + 11.3) [mm]	(Paper length + 11.3) [mm]	(Paper length + 11.3) x 2 [mm]
PDPPD2_N	Interface outlet port not-reached JAM	PDPPD1 ON	PDPPD2 does not turn ON within the specified time.	318.7 [mm]	318.7 [mm]	637.4 [mm]
PDPPD2_S	Interface outlet port remaining JAM	PDPPD2 ON	PDPPD2 does not turn OFF within the specified time.	(Paper length + 11.3) [mm]	(Paper length + 11.3) [mm]	(Paper length + 11.3) x 2 [mm]
FPPD1_N	Finisher inlet port not-reached JAM	PDPPD2 ON	FPPD1 does not turn ON within the specified time.	180.3 [mm]	180.3 [mm]	360.6 [mm]
FPPD1_S	Finisher inlet port remaining JAM	Paper reaches the finisher speed change position.	FPPD1 does not turn OFF within the specified time.	108.4 [mm]	216.8 [mm]	325.2 [mm]
FPPD2_N	Saddle section not-reached JAM	The lead edge of paper reaches the position of 20mm past the saddle No. 1 transport roller.	FPPD2 does not turn ON within the specified time.	110.4 [mm]	110.4 [mm]	220.8 [mm]
FPPD2_S	Saddle section remaining JAM	The rear edge of paper reaches the position of 20mm past the process roller.	FPPD2 does not turn OFF within the specified time.	220.4 [mm]	220.4 [mm]	440.8 [mm]
FPDD_S	Bundle exit remaining JAM	Gripper discharging is started.	FATPD does not turn OFF within the specified time.	437 [msec]	437 [msec]	874 [msec]
		Gripper discharging is completed.	FPDD does not turn ON when gripper discharging is completed.			FPDD OFF

JAM code	JAM content	JAM detection method		Basic distance (A) [msec]	JAM margin distance (B) [mm]	JAM detection distance (A+B) [mm]
		JAM detection start trigger	JAM judgment condition			
FSTPLJ	Staple JAM	Driving the staple motor is started.	FSSHS ON is not detected within the specified time after detection of FSSHS OFF during stapling operation, and FSSHS ON is detected by reverse rotation of the staple motor after stapling operation is stopped.	400 [msec]	200 [msec]	600 [msec]
		Staple extending operation is started.	Staple extending cannot be executed by execution of staple feeding by the specified number of times (9 times) during staple extending operation.			9 times
		Driving the saddle staple motor is started.	FSSHS ON is not detected within the specified time after detection of FSSHS OFF during stapling operation, and FSSHS ON is detected by reverse rotation of the staple motor after stapling operation is stopped.	480 [msec]	240 [msec]	720 [msec]
		Saddle staple extending operation is started.	Staple extending cannot be executed by execution of staple feeding by the specified number of times (14 times) during staple extending operation.			14 times
FPNCHJ	Punch JAM	Punch motor stop	FPCHPS does not turn ON after punching operation.			FPCHPS OFF
FIN_TIME	Finisher paper early reaching JAM	Paper exit command of the preceding paper	The paper exit command of the next paper is received at the timing earlier than the specified paper interval.	Specified paper interval time	150 [msec]	(Specified paper interval time) - 150 [msec]
FIN_PAOF	Paper attribute data reception overflow	Paper information data command is received.	Paper information data of more than allowable buffer (16 sheets) are received.			16 sheets
FPATPD_S	Saddle transport remaining JAM	Transport operation is started after folding operation.	FSATPD does not turn OFF within the specified time.	(Paper length/ 2 - 26.2) [mm]	(Paper length/ 2 - 26.2) [mm]	(Paper length/ 2 - 26.2) x 2 [mm]
FPPD3_N	Saddle paper exit not-reached JAM	Thrusting operation is started.	FPPD3 does not turn ON within the specified time.	66.9 [mm]	66.9 [mm]	133.8 [mm]
FPPD3_S	Saddle paper exit remaining JAM	Transport operation is started after folding operation.	FPPD3 does not turn OFF within the specified time.	(Paper length/ 2 - 26.2) [mm]	(Paper length/ 2 - 26.2) [mm]	(Paper length/ 2 - 26.2) x 2 [mm]
FSSMJ	Stapler shift motor JAM	Driving the stapler shift motor is started.	Change from FSSHPS ON to OFF is not detected within the specified time during the stapler shift operation.	1434 [msec]	1434 [msec]	2868 [msec]
			Change from FSSHPS OFF to ON is not detected within the specified time during the stapler shift operation.	2085 [msec]	2085 [msec]	4170 [msec]
			Change from FSSSHPS ON to OFF is not detected within the specified time during the stapler shift operation.	401 [msec]	401 [msec]	802 [msec]
			Change from FSSSHPS OFF to ON is not detected within the specified time during the stapler shift operation.	3179 [msec]	3179 [msec]	6358 [msec]
			Change from FSSSW2 ON to OFF is not detected within the specified time during the stapler shift operation.	138 - 503 [msec]	138 - 503 [msec]	276 - 1006 [msec]
			Change from FSSSW2 OFF to ON is not detected within the specified time during the stapler shift operation.	291 - 803 [msec]	291 - 803 [msec]	582 - 1606 [msec]
FDRLMJ	Paper exit roller lift motor JAM	Driving the finisher paper exit roller lift motor is started.	Change from FDRHS ON to OFF is not detected within the specified time during the paper exit roller lift operation.	176 [msec]	176 [msec]	352 [msec]
			Change from FDRHS OFF to ON is not detected within the specified time during the paper exit roller lift operation.	235 [msec]	235 [msec]	470 [msec]
FSDMJ	Saddle motor JAM		JAM which is not detected yet			

JAM code	JAM content	JAM detection method		Basic distance (A) [mm]	JAM margin distance (B) [mm]	JAM detection distance (A+B) [mm]
		JAM detection start trigger	JAM judgment condition			
FGMJ	Gripper motor JAM	Driving the gripper motor is started.	Change from FGHP ON to OFF is not detected within the specified time during the gripper operation.	187 [msec]	187 [msec]	374 [msec]
			Change from FGHP OFF to ON is not detected within the specified time during the gripper operation.	535 [msec]	535 [msec]	1070 [msec]
FSPTMJ	Saddle paper transport motor JAM	Driving the saddle paper transport motor is started.	Change from FSRHS ON to OFF is not detected within the specified time during the paper transport roller lift operation in the saddle section.	37 [msec]	37 [msec]	74 [msec]
			Change from FSRHS OFF to ON is not detected within the specified time during the paper transport roller lift operation in the saddle section.	24 [msec]	24 [msec]	48 [msec]

### 3. Image send communication report code

#### A. Outline and code system descriptions

After completion of communication, the communication report table, the communication management table, and the protocol are described on the communication report column.

The communication report code is composed as follows:

Communication report: XX (XXXX)

The upper 2 digits of the communication report code:

Communication report code of 00 – 99 (Refer to communication report main code.)

The lower 4 digits of the communication report code:

Used by the serviceman.

The upper 2 digits: Communication report sub code 1 (Refer to communication report sub code 1.)

The lower 2 digits: Communication report sub code 2 (Refer to communication report sub code 2.)

**Important**

The communication report sub code 1 and sub code 2 are in hexadecimal notation. (The others are in decimal notation.)

**Important**

The communication report sub code 1 is not used in the these models.

#### B. Details

##### (1) Communication report main code

Report code	Final receive signal (Send side)	Final receive signal (Receive side)
0	Abnormal signal	Abnormal signal
1	NSF, DIS	(SID), (SUB), NSS, DCS
2	CFR	(PWD), (SEP), NSC, DTC
3	FTT	EOP
4	MCF	EOM
5	PIP, PIN	MPS
6	RTN, RTP	PRI-Q
7	No signal, DCN	DCN
8	PPR	PPS-EOP
9		PPS-EOM
10		PPS-MPS, PPS-NULL
11	RNR	RR
12	CTR	CTC
13	ERR	EOR-Q
14		PPS-PRI-Q
16	Abnormal signal	Abnormal signal
17	NSF, DIS	SID, SUB, NSS, DCS
18	CFR	PWD, SEP, NSC, DTC
19	FTT	PPS-EOP
20	MCF	PPS-EOM
21	PIP, PIN	PPS-MPS, PPS-NULL
22	RTN, RTP	PRI-Q
23	No signal, DCN	DCN
24	PPR	
25	RNR	RR
26	CTR	CTC
27	ERR	EOR-Q
28		PPS-PRI-Q
29	V.8 Phase-1	V.8 Phase-1
30	V.8 Phase-2	V.8 Phase-2
31	V.8 Phase-3	V.8 Phase-3

**Important**

For report codes 16 – 31, V.34 MODE COMMUNICATION.

Report code (Communication result)	Display in the column of result	Content of communication interruption
0 – 31	Refer to "previous table".	Depends on the point of communication interruption. For 16 or later, V.34 mode communication.
33	BUSY	The calling side cannot establish connection with the remote party.
34	CANCEL	A communication interruption command is made during sending/receiving. The interruption key is pressed for interruption of input. <Send/Receive/Polling/Bulletin board>
35	NG35 XXXX	Power is failed during sending/receiving. <Send/Receive/Polling/Bulletin board>
36	(No record paper)	
37	(Record paper jam)	
38	MEM. FULL	Memory over during reception. <Receive/Polling> Print is not made during reception in acting reception inhibit. <Receive/Polling>
39	(Number of paper unmatched)	
40	(Relay not received)	
41	LENGTH OVER	The send data length of one page exceeds the limit (2m) in sending. <Send/Bulletin board>
42	LENGTH OVER	The receive data length of one page exceeds the limit. <Receive/Polling>
43	(Communication) (OK)	Speaking before data transmission
44	ORIGINAL ERROR	A document jam occurs in direct sending. <Send>
45	(Picture quality error)	
46	NO RESPONSE	The FAX signal from the remote party is not detected within T1 time. <Send/Polling> (When in recall, however, the recall setting in case of a communication error is valid.)
47	TX DECODE ERROR	A decode error occurs in the FAX board. <Send/Bulletin board>
48	OK	Normal end of communication
	OK REPLY RECEIVE	OK in Internet FAX send with reception confirmation.
49	NO RX POLL	The called side does not have polling function in polling reception. <Polling> The called side has no data to send. <Polling>
50	RX POLL FAIL	In polling reception, DCN is received for DTC. <Polling> In polling sending, there is no send data. <Bulletin board>
51	PASS # NG	In polling sending, the allow number is not matched. <Bulletin board> In polling sending, the system number is not matched. <Bulletin board>
52	(No confidential function in remote party)	In confidential sending, the remote party does not have confidential function. <Send> (Including other company's machines) 1) The NSF signal has not "Confidential function" bit. 2) The NSF is not a Sharp machine.
53	(Confidential not received)	1) In confidential sending, DCN is received for NSS. <Send>
54	(Confidential BOX NO NG)	1) In confidential reception, a confidential box number which is not registered is specified.
55	(No relay function in remote party)	In relay command sending, the remote machine has no relay function. <Send> (Including other company's machine) 1) The NSF signal has not "Confidential function" bit. 2) The NSF is not a Sharp machine.
56	NO REL RX	1) In relay command sending, DCN is received for NSS. <Send> 2) In relay command reception, a remote station number which is not registered is specified. <Receive> 3) In F code relay broadcasting, an F code relay command is received. <Receive>
57	(Relay ID unmatched)	1) In relay command reception, the relay ID does not match. <Receive>
58	REJECTED	In reception, data are sent from a remote machine of receive inhibit number. <Receive> (Not rejected in the bulletin board send or the F code bulletin board send.)
59	RX NO F-CODE POLL	In F code polling (calling), the remote machine has no DIS bit 47 (polling function). <Polling> In F code polling (calling), the called side has no send data. (DIS bit 9 is 0.) <Polling>
60	NO F-CODE POLL	In F code polling (calling), DCN is received for SEP. <Polling> In bulletin board, there is no send data for SEP. <Bulletin board>
61	RX POLL # NG	In bulletin board, the sub address (bulletin board number (SEP)) is not matched. <Bulletin board>
62	F POLL PASS # NG	In bulleting board, the pass code (PWD) is not matched. <Bulletin board>
63	NO F FUNC	In F code sending, the remote machine has no DIS bit 49 (sub address function). <Send> (Check that the remote machine conforms to F code.)
64	NO F-CODE	In F code sending : <Send> 1) DCN is received for SUB. --- Check the box number. 2) DCN is received for SID. --- Check the box number and pass code.  In F code receiving : <Receive> "F code relay broadcasting" or "F code confidential reception" is "Inhibited with soft SW."
67	F PASS # NG	In F code receiving, the pass code (SID) is not matched. <Receive>
68	BOX NO. NG	In F code reception, a box number which is not registered is specified. (SUB is not matched.) <Receive>
69	MEMORY OVER	Memory over in quick online sending <Send>
70	(JOB MEMORY OVER)	In PC-FAX reservation, the number of remote parties is exceeded. <Send>
71	NG71 XXXX *1	In PC-FAX reservation, data sent from PC includes some errors. <Send>
72	(NG72 XXXX) *1	In department management setting on the machine side: • In reservation from PC-FAX or PC-Internet FAX, a department number which is not registered on the machine side is specified. <Send> • In reservation from PC-FAX or PC-Internet FAX, the department number is not specified. <Send>
73	NG73 XXXX *1	In reservation from PC-FAX or PC-Internet FAX, the use quantity limit is exceeded. <Send>
74	NG74 XXXX *1	When reserving specified filing in document filing in PC-FAX or PC-Internet FAX; • The pass-code for the folder is set on the machine side and the pass-code from PC-XXX does not match with it. <Send> • The pass-code for the folder is set on the machine side and no pass-code is specified by PC-XXX. <Send>



Report code (Communication result)	Display in the column of result	Content of communication interruption
75	NG75 XXXX *1	<ul style="list-style-type: none"> <li>Reservation cannot be made due to machine busy. (Reservation of PC-FAX cannot be accepted.)</li> <li>When "PC-FAX or PC-internet FAX send inhibit" is set on the machine side.</li> </ul>
76	NG76 XXXX *1	Reserved with receive confirmation request in PC-Internet FAX, but the Internet FAX sender is not registered on the machine side. <Send>
77	NG77 XXXX *1	In reserving specified filing in PC-FAX or PC-Internet FAX, the machine has no filing function.
78	NG78 XXXX *1	The filing function is inhibited on the machine side when filing specification is reserved by PC-FAX or PC-Internet FAX.
79	NG79 XXXX *1	An authentication error occurs when PC-FAX or PC-Internet FAX is reserved.
80	NG80 XXXX *1	NIC connect failure (network abnormality) <ul style="list-style-type: none"> <li>Check for disconnection of cables.</li> <li>A network trouble (CE-XX) occurs.</li> <li>The port is set to DISABLE.</li> <li>Authentication of the POP server is failed when POP before SMTP is enabled.</li> <li>When an error other than the communication result code 93 or 94 in D-SMTP send (including error response of 5XX)</li> </ul>
81	NG REPORT	In Internet FAX send, reply of receive confirmation of the remote machine is not normal. (Including PC-Internet FAX). <ul style="list-style-type: none"> <li>Error of the disposition-modifier.</li> <li>The disposition modifier is not in an error, and the disposition type is other than displayed, dispatched, or processed.</li> </ul>
82	NO REPORT	In Internet FAX send, time-out occurs in waiting for receive confirmation from the remote machine. (Including PC-Internet FAX). <ul style="list-style-type: none"> <li>In a case where send confirmation wait time-out time is other than 0, when send confirmation reply from an Internet FAX destination is not received.</li> <li>Recalls of the set number of recalls are performed, but send confirmation reply from an internet FAX destination is not received.</li> </ul>
83	NG LIMIT	In E-mail/FTP, Internet FAX send, the send data size exceeds the upper limit of send data.
84	REJECTED	In e-mail receive, a sender is registered in receive reject address/domain. <Receive>
85	NG85 XXXX *1	In e-mail receive, an error occurs in communication with POP3 server. <ul style="list-style-type: none"> <li>Header acquisition error.</li> <li>Time-out during mail receive</li> </ul>
86	RECEIVED	In e-mail receive, an unsupported attached file is received. Only the TIFF-F type is supported for attached files. <ul style="list-style-type: none"> <li>The TIFF-F type of the attached file cannot be recognized.</li> <li>There is no attached file.</li> </ul>
87	NG87 XXXX *1	In e-mail receive, an attached file cannot be stored in memory. <ul style="list-style-type: none"> <li>Memory over</li> </ul>
88	NG88 XXXX *1	In SMTP e-mail receive, an attached file cannot be stored in memory. <ul style="list-style-type: none"> <li>Cannot be stored in memory.</li> <li>The number of items of acting receive data is the maximum, and an additional data cannot be stored.</li> </ul>
89	NG89 XXXX *1	In SMTP e-mail receive, an error occurs in communication with the mail server. <ul style="list-style-type: none"> <li>Time-out occurs during e-mail receive.</li> </ul>
90	NG90 XXXX *1	After reservation by re-operation of document filing, conversion for image send cannot be made.
91	NG91 XXXX *1 *2	Data cannot be written to the memory device when Scan To USB is executed. <ul style="list-style-type: none"> <li>The memory device is disconnected during writing to the memory device.</li> <li>An error occurs due to a memory device trouble.</li> </ul>
92	NG92 XXXX *1 *2	The USB device memory overflows during writing data into the memory device when "Scan to USB" is executed.
93	NG93 XXXX *1	When error in D-SMTP send (with recall) <ul style="list-style-type: none"> <li>An error response of 4XX occurs during communication with the SMTP server.</li> <li>Time out occurs after establishment of connection with the SMTP server.</li> </ul>
94	NG94 XXXX *1	When busy in D-SMTP send <ul style="list-style-type: none"> <li>Time out occurs during establishment of connection with the SMTP server.</li> </ul>
95	NG95 XXXX *1	When the path is too long in execution of Scan To USB.
96	NG96 XXXX *1	When the normal process is not executed in the secure mail sending.
98	NG98 XXXX *1	The copy inhibit pattern is detected when scanning a document.
99	NG99 XXXX *1	A document which is inhibited to be copied such as a banknote is scanned.

\*1: For a job status result in "Display in the column of result," "NG △△ XXXX" is displayed. "△△" is the code number.

For a communication result, "Communication error △△ (XXXX)" is displayed.

\*2: The error code of Scan To USB is specified only in the job log.

- When the communication result is OK, the communication sub code 1 and the communication sub code 2 are "0000."
- Errors in ( ) are not used.

## (2) Communication report sub code 1

The communication report sub code 1 (upper 2 digits) are always indicated as "00."

## (3) Communication report sub code 2

Report code 2	Content of communication interruption	Send/Receive
00	When the conditions after 01 do not apply.	Send/Receive
01	Send length over	Send
02	EOL time up	Receive
03	Carrier detection time up	Receive
04	Time up of the communication start command from the machine side	Receive
05	Time up in phase C (8 min)	Send
06	Memory image decode error	Receive
07	Memory image decode error	Send
08	Time up between frames in phase C (Report code is 0 or 16.)	Send/Receive
09	Not used	—
10	Not used	—
11	Polarity reversion detection	Receive
12	Invalid command reception	Receive
13	Time up (1-minute timer/6-second time)	Receive
14	PUT error	Receive
15	In V.34 mode, time up is generated when shifting from Primary to Control.	Receive
16	In V.34 mode, time up is generated when shifting from Control to Primary.	Receive
17	Command receive time-up from MFP controller	Receive
18	Not used	—
19	Not used	—
20	Polarity reversion detection	Send
21	Invalid command reception	Send
22	Fallback retry number over	Send
23	Command retry number resend over	Send
24	Time up (T5 timer)	Send
25	Time up (T5 timer) in V.34 mode	Send
26	In V.34 mode, time up is generated when shifting from Primary to Control.	Send
27	In V.34 mode, time up is generated when shifting from Control to Primary.	Send
28	When sending the FSK signal, no response of send completion is sent back from the MODEM chip within a certain time. (V.34, other than V.34)	Send
29	Not used	—
30	A communication error is generated between MFP controller and Modem controller. (Report code is 0 or 16.)	—
31	DC current not detected (busy)	Send
32	Dial tone not detected (busy)	Send
33	Busy tone detection (busy)	Send
34	T0 time up (Remote machine not responding)	Send
35	T1 time up (Remote machine not responding)	Send
36	In dialing, polarity reversion detection (Remote machine not responding)	Send
37	Calling is not made (busy)<Collision detected (including CNG detection)>	Send
38	Not used	—
60	In resend of document filed data, an error occurs in decoding or coding.	Resend
61	In resend of document filed data, setting to inhibit resolution conversion is made. (The resolution after resend is set to be Enlarged.)	Resend
62	In resend of document filed data, rotation setting is made for data which cannot be rotated.	Resend
63	In resend of document filed data, data cannot be stored in HD after conversion of resolution for resend.	Resend
64	In resending data of document file, during conversion for resending, the number of IMS management pages exceeds the upper limit (999). (IT occurs in OSA Scan to FTP also, resulting in memory over.)	Resend OSAScanToFTP
70	E-mail header acquisition error	E-mail receive
71	Time out occurs during e-mail receive.	E-mail receive
72	Receive reject occurs during e-mail receive.	E-mail receive
73	Network communication cannot be made due to port disable.	Network send
74	An authentication of the POP server is failed when POP before SMTP is enabled.	Network send
75	In the setting of SSL communication, when SSL communication is tried but the server side does not support SSL.	Network send
76	There is no image in network communication (transfer).	Network send
80	There is no attached file in received e-mail.	E-mail receive
81	The attached file of received e-mail is not of TIFF type which is supported.	E-mail receive
82	The TIFF type of the attached file in received e-mail cannot be recognized. ID error	E-mail receive
83	The TIFF type of the attached file in received e-mail cannot be recognized. Endian error	E-mail receive
84	The TIFF type of the attached file in received e-mail cannot be recognized. Version error	E-mail receive
85	The TIFF type of the attached file in received e-mail cannot be recognized. Tag data error	E-mail receive
86	The TIFF type of the attached file in received e-mail cannot be recognized. Tag parameter error	E-mail receive
87	The TIFF type of the attached file in received e-mail cannot be recognized. Header size error	E-mail receive

Report code 2	Content of communication interruption	Send/Receive
88	The TIFF type of the attached file in received e-mail cannot be recognized. Data error	E-mail receive
90	In e-mail receive, an attached file cannot be stored in memory. Memory over. Cannot be stored in memory.	E-mail receive
91	In e-mail receive, an attached file cannot be stored in memory. The file size is too great to be stored in memory.	E-mail receive
92	In SMTP e-mail receive, an attached file cannot be stored in memory. Cannot be stored in memory.	E-mail receive

When the sub code 2 is "08" or "30" and the communication report is "OK," the report code is "00" or "16."

#### 4. Dial tone

When shipping from the factory, the dial tone detection when sending is set to Enable (changed from OFF to ON). When installing this machine, be sure to check and confirm that the dial tone is properly detected and the auto dial sending is enabled.

Check to confirm that the continuous buzzer sound is heard when the on-hook key is pressed. (Press the on-hook key again to cancel the buzzer sound.)

If facsimile communication cannot be executed normally through the IP telephone line, try the general telephone line.

# [7] FIRMWARE UPDATE

## 1. Outline

### A. Cases where update is required

ROM update is required in the following cases:

- 1) When there is a necessity to upgrade the performance.
- 2) When installing a new spare part ROM for repair to the machine.
- 3) When installing a new spare parts PWB unit (with ROM) for repair to the machine.
- 4) When there is a trouble in the ROM program and it must be repaired.

### B. Notes for update

#### (1) Relationship between each ROM and update

Before execution of ROM update, check combinations with ROM's installed in the other PWB's including options. Some combinations of each ROM's versions may cause malfunctions of the machine.

### C. Update procedures and kinds of firmware

There are following methods of update of the firmware.

- 1) Update method using SIM 49-1
- 2) Update method using FTP
- 3) Update method using the Web page
- 4) Update method using the CN update function (There are three methods.)

Normally, one of 1) - 3) is used to update the firmware.

When any one of 1) - 3) is interrupted by an error such as power-off during updating, etc., and when retries of these methods are failed, the method 4) is employed.

#### Firmware types

The firmware type can be displayed by SIM22-5.

Use SIM22-5 to check the firmware type.

## 2. Update procedure

### A. Update method using SIM 49-1

For the update, connect the media or USB memory to the USB port that exists in the main body, and select the firmware data in the media or USB memory by simulation screen in the main unit.

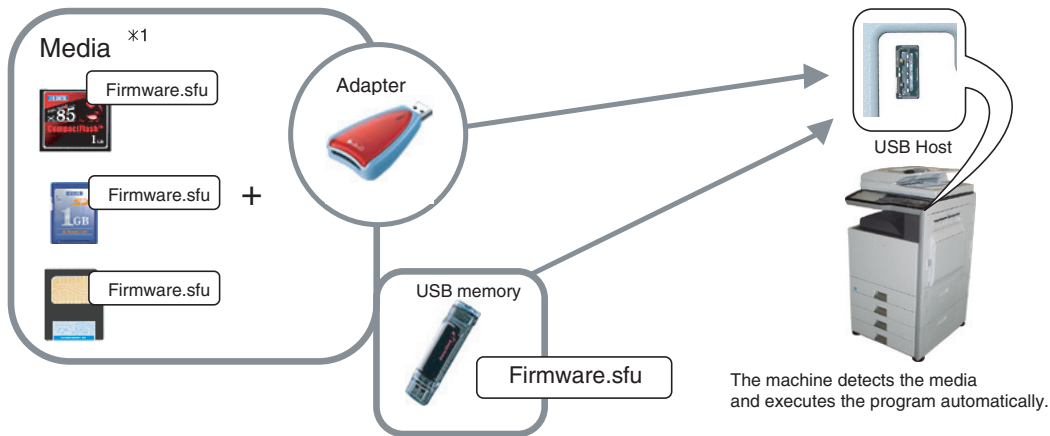

\*1:

- Store the firmware data (xxx .sfu) to the media or USB memory beforehand.
- The media used for the update must have an enough capacity for storing the firmware data.
- The USB memory equipped with the security (secure) function cannot be used.

### Execution of the firmware by SIM49-01

- 1) Insert the media or USB memory which stores the firmware into the main unit. (Be sure to use the USB I/F on the operation panel.)
- 2) Enter the SIM49-01.

Press the key of the file to be updated. The screen transfers to the update screen.

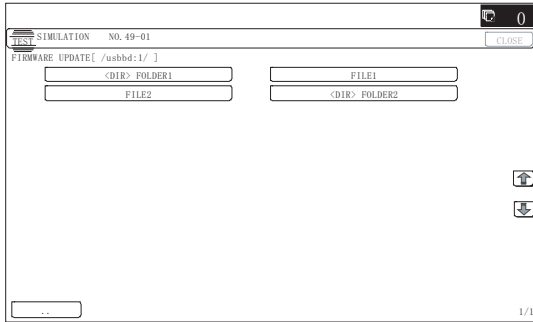

- \* The number of key changes according to the number of the sfu file in the media or USB memory inserted.
- \* If the media or USB memory was not inserted when entry to the SIM49-01 screen, "INSERT A USB MEMORY DEVICE CONTAINING MFP FIRMWARE [OK]" is displayed on the screen. Insert the media or USB memory and push the [OK] key to open the file. If the media have not been inserted and [OK] key is pushed, the next screen does not appear and the screen waits the entry. Conversely, if the media or USB memory is pulled out on the file list screen, the error is detected by the [FILE] key pressing, and the first screen appears.

- 3) Current version number and the version number to be updated will be shown for each firmware respectively.

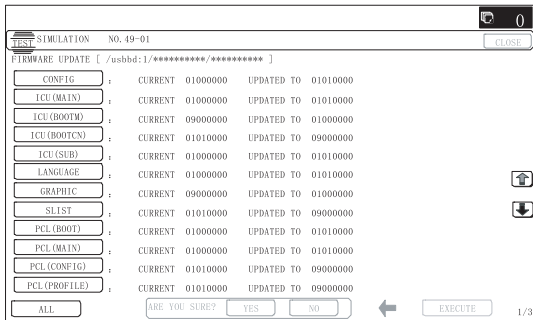

- 4) Press [ALL] key.  
All the firmware programs are selected.

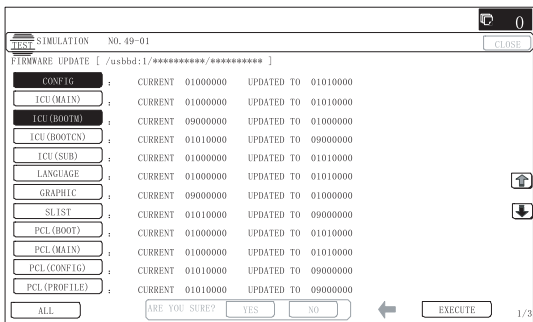

- \* Normally select all the firmwares and execute updating.
- \* In this case, firmwares which do not exist on the machine side are ignored.  
To update a certain firmware only, select the firmware with the firmware display key.
- \* If firmware's key is not selected, [EXECUTE] key is gray out and cannot be pressed.

- 5) Press [EXECUTE] key. "ARE YOU SURE? [YES] [NO]" becomes clear. Press [YES] key to start the update of selected firmware.

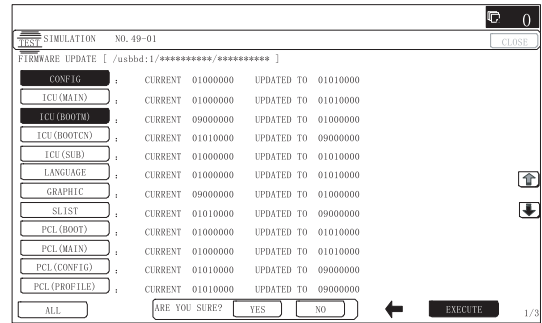

The progress is displayed on right side of "FIRMWARE UPDATE" title by 20 steps.

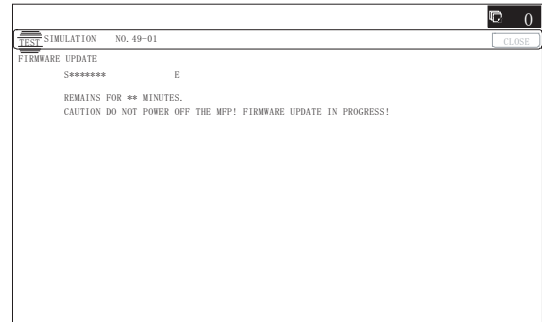

At this time, only the progress gauge is displayed on the screen, and the version and the firmware selection key are not displayed.

- 6) If the update is normal completion, following screen is displayed.



Press [OK] key. (The machine is rebooted.)

Go to SIM22-05 and confirm the firmware has upgraded successfully.

- 7) If the update is not normal completion, following screen is displayed.

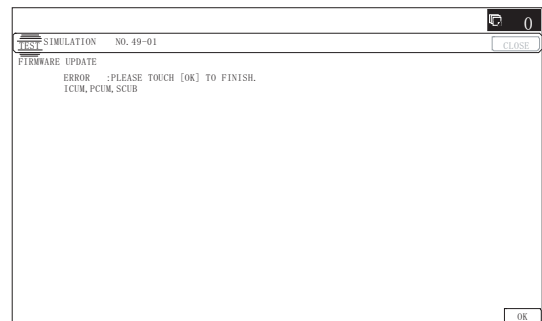

## B. Firmware update using FTP

FTP software is used to transfer the firmware data (extension ".sfu") from the PC to the machine. The controller recognizes the firmware identifier and the machine automatically switches to firmware write mode. After the firmware is updated, the machine automatically resets.

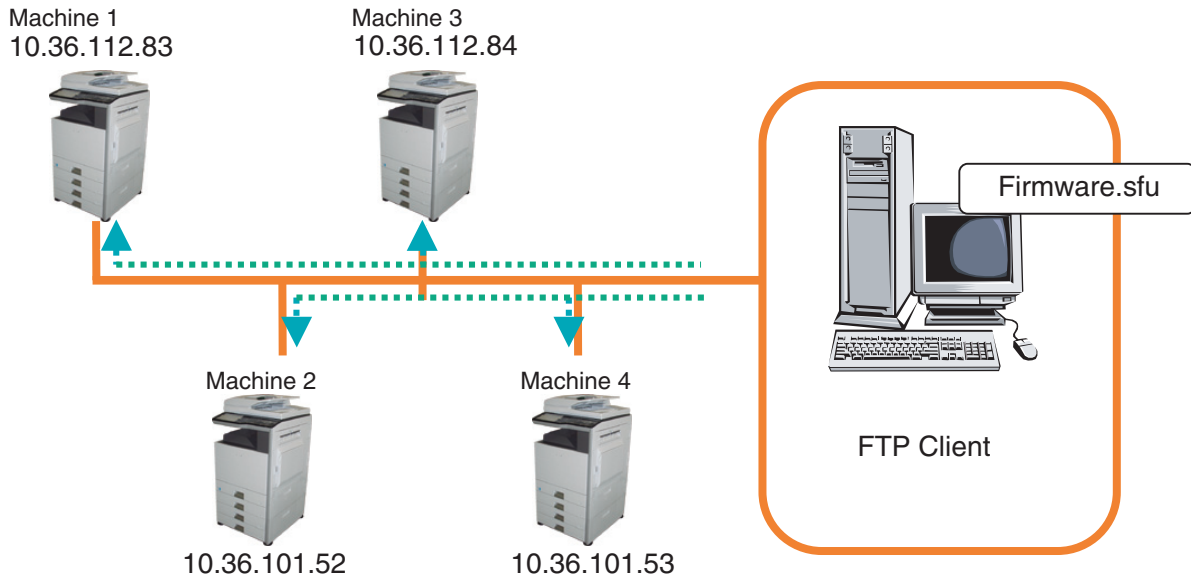

## C. Firmware update using the Web page

An Web browser (service technician's Web page) is used to update the firmware.

- 1) Start the Web browser on a PC and enter the specified URL. A special firmware upgrade page appears.
- 2) Click the "Update of Firmware" key in the Web page. Click the [Browse] key and select the firmware for the update.

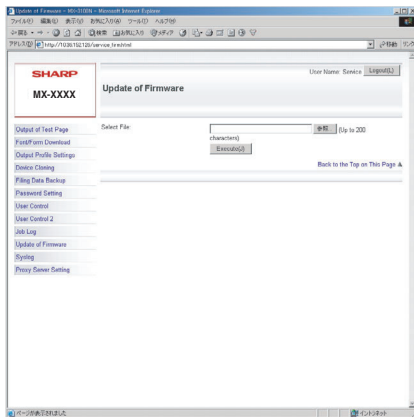

- 3) After selecting the file, click the [Submit] key to send the firmware to the machine. Update processing begins. While processing takes place, "Firmware Update, now processing..." appears.

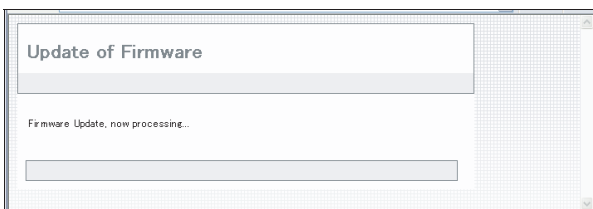

- 4) When the firmware update is finished, "Firmware Update completed. Please reboot the MFP." appears. Pressing the [Reboot] key, the machine will restart to complete the update. The browser will shift to the following screen.

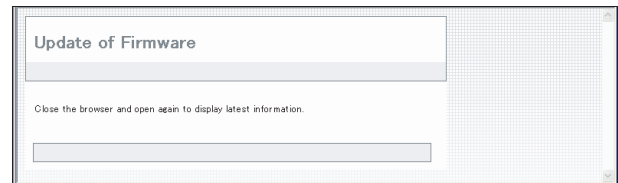

"Close the browser and open again to display latest information." will be displayed.

- 5) Check the firmware version of machine again.

## D. Firmware update using the CN update function (There are three methods.)

### (1) Outline

The update method using the DIP SW of the MFP PWB is called the CN update.

#### a. Function

There are the following three functions in the CN update mode.

##### 1) Firmware update function

This function is used to update the firmware by transferring data from the PC which is connected to the MFP PWB, the SCU PWB, the PCU PWB, the FAX PWB, and various options by means of a USB memory or USB cable.

This is basically the same as SIM49-01, but differs in the following points:

When the power is shut down or an abnormality occurs in a section other than the boot program for some reasons during firmware update operation of other method than the CN update, this method can be used to update the firmware.

If, however, an abnormality occurs in the boot program, the SD card must be replaced with a new one having the normal boot program.

If the boot animation is not displayed, there is an abnormality in the boot program.

If the boot animation is displayed but "Copying is enabled" is not displayed on the copier basic menu, there is an abnormality in the main program.

##### 2) Firmware version check function

(The method to check the firmware version by using SIM22-5 is easier than this method. Therefore, it is not described in this manual.)

##### 3) ROM making function

(This function is not used in the market, and not described in this manual.)

#### b. Purpose

This function is used in the following cases:

##### 1) When an error occurs during firmware update operation other than the CN update.

When the power is shut down or an error occurs in a section other than the boot program for some reasons during firmware update operation of other method than the CN update, this method can be used to update the firmware.

If, however, an abnormality occurs in the boot program, the SD card must be replaced with a new one having the normal boot program.

If an error occurs in the boot program, this method cannot be used. In such a case, the SD card must be replaced with a new one having the normal boot program.

#### c. DIP-SW used in the CN update mode

To enter the CN update mode, turn ON the UPDATE DIP-SW on the MFP PWB and boot the machine.

When terminating the CN update mode, reset UPDATE DIP-SW to OFF (normal mode).



#### d. Keys used in the CN update mode

The following five keys are used for operations in the CN update mode. Be careful that the functions of the keys differ those in the normal mode.

##### • 18cpm/20cpm/23cpm/31cpm(G) machine

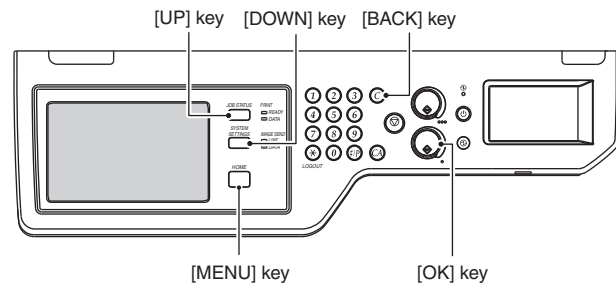

##### • 26cpm/36cpm/31cpm(A) machine

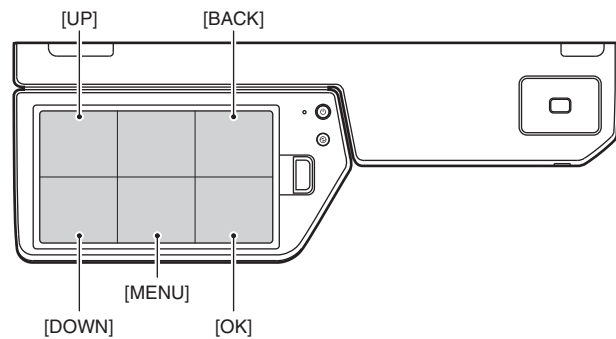

Key name	Functions in the CN update mode
[OK] key	Executes the selected function or item.
[MENU] key	Selects a menu.
[BACK] key	Selects a menu. (Serves as a cancel key in the execution check screen.)
[UP] key	Selects an item.
[DOWN] key	Selects an item.

## (2) Operating procedures

### a. Firmware update function

This function is used to revise the firmware by using the USB memory for the MFP PWB, the SCU PWB, the PCU PWB, the FAX PWB, and each option.

It is basically same as SIM 49-01, but differs in the following points.

- 1) The update target ROM is automatically selected.
- 2) When the power is shut down or an abnormality occurs in a section other than the boot program for some reasons during firmware update operation of other method than the CN update.

If, however, an abnormality occurs in the boot program, this method cannot be used. On that case, the SD card must be replaced with a new one having the normal boot program.

When the boot animation is displayed but "Copying is enabled" is not displayed on the copier basic menu, there is an abnormality in the main program (SD card).

#### a-1. Necessary items

- 1) Insert the SD card to the MFP PWB of the machine.
- 2) USB memory with the firmware file (SFU) saved in it.

#### Note

Save the firmware file in the main directory or in a one-level lower directory.

#### a-2. Procedures

- 1) Turn OFF the power, and remove the cabinet and the MFP PWB cover.
- 2) Turn ON the DIP SW of the MFP PWB UP DATE. (Tilt it to the PWB side.)
- 3) Install the USB memory into the USB port.

#### USB memory installing position

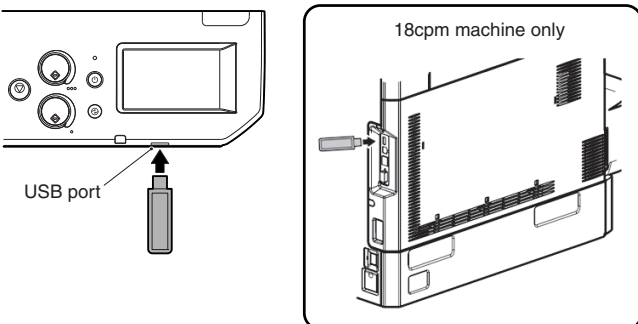

- 4) Turn ON the power.
- 5) Check to confirm that the machine starts booting. (It takes more than ten seconds to display the menu.)

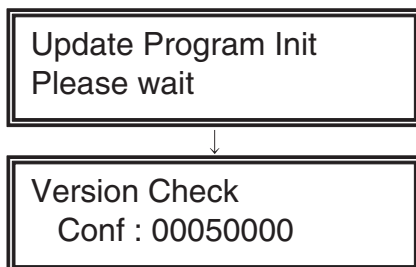

Display when booting is completed

- 6) Select the firmware update mode.  
Select the update mode with [MENU] key and [BACK] key.



Display of the firmware update mode

- 7) Press [OK] key.  
The firmware file saved in the USB memory is retrieved, and the file selection menu is displayed.



Display of file selection

- 8) Select the firmware file (SFU).  
Select the target firmware file (SFU) with [UP] key and [DOWN] key.

When [OK] key is pressed with a directory name (the head: "> D") displayed, the menu goes to the one-stage lower directory. When [BACK] key is pressed in the lower-stage directory, the menu returns to the original upper directory.

- 9) Press [OK] key.  
The selected firmware file (SFU) is read. It takes about one minute.



Display of file reading

- 10) After completion of reading, the firmware update process is continued.

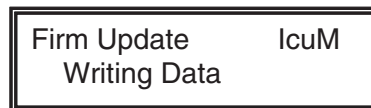

Display of the firmware update process

\* The abbreviated name of the firmware which is under update process is indicated on the right upper corner of the display.

\* During the update process, the display may flash instantaneously. It is a normal operation.

- 11) Check the update result.  
Use [UP] key and [DOWN] key to display the results of all the firmware programs.

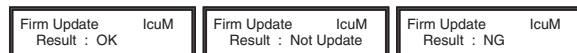

Display of the firmware update result

OK: Update is completed successfully.

NG: Update is failed.

Not Update: Update is not executed.

- 12) Turn OFF the power.
- 13) Turn OFF the DIP SW of the MFP PWB UP DATE. (Set the DIP-SW to the normal mode.)
- 14) Turn ON the power, and check to confirm that the machine boots up normally.  
Check to confirm that the boot animation is displayed.  
Check to confirm that "Copying is enabled" is displayed on the copier basic menu.
- 15) Check to confirm the version of each firmware with SIM22-5.
- 16) Attach the MFP PWB cover and the cabinet.



## [8] MAINTENANCE

### 1. Works necessary when executing the maintenance

#### A. Counter check

Before execution of the maintenance, execute SIM22 to check the counter values of the following counters to confirm consuming states of each section.

- 1) Each consumable part counter
- 2) Each unit counter
- 3) Trouble counter, JAM counter

#### B. Counter reset

When a part or consumable part is replaced with new one in the maintenance, execute SIM24 to reset the following counters.

- 1) Maintenance counter
- 2) Each consumable part counter
- 3) Each unit counter
- 4) Trouble counter, JAM counter

#### C. Firmware version check and upgrading

Execute SIM22-5 to check the firmware version, and upgrade it as needed. (SIM49-1)

#### D. Confirmation, adjustment

After completion of part replacement and cleaning, etc, execute the following procedures.

##### Items necessary to execute

Item				SIM to be used
ADJ 5	Print engine image distortion adjustment / OPC drum phase adjustment / Color registration adjustment (Print engine section)	ADJ5A	Print engine image distortion adjustment (Manual adjustment) / OPC drum phase adjustment (Automatic adjustment) / Color registration adjustment (Automatic adjustment)	50-22
ADJ10/SET1	Image quality adjustment		Copy image quality adjustment	
			Printer image quality adjustment	
		ADJ10B	Printer, copy color balance, density adjustments (Automatic adjustments) (Basic adjustments)	46-74

##### Items to execute as needed

Item				SIM to be used
ADJ 2	High voltage adjustment	ADJ2A	Main charger grid voltage adjustments	8-2
		ADJ2B	Developing bias voltage adjustments	8-1
		ADJ2C	Transfer current/voltage adjustment	8-6
ADJ 3	Image density sensor adjustment	ADJ3A	Image density sensor calibration	44-13
		ADJ3B	Image density sensor adjustment	44-2
ADJ4	Image lead edge position, image loss, void area, image off-center, image magnification ratio adjustments (Automatic adjustments)	ADJ4A	Print image main scanning direction automatic magnification ratio adjustment (Print engine)	50-28
		ADJ4B	Print image off-center automatic adjustment (Print engine) (Each paper feed tray)	50-28
		ADJ4C	Copy mode image lead edge position, image loss, void area, image off-center, sub scanning direction image magnification ratio automatic adjustment (Scanner) (Document table mode)	50-28
		ADJ4D	Copy mode image lead edge position, image loss, void area, image off-center, sub scanning direction image magnification ratio automatic adjustment (Scanner) (RSPF mode)	50-28
ADJ10/SET1	Image quality adjustment	ADJ10A	Scanner calibration (CCD calibration)	63-3 (63-5)

## 2. Display of maintenance execution timing

The message of maintenance execution timing is displayed when each counter reaches the set value. The relations between the messages and the counters are shown below.

### A. Maintenance counter

Display content	Display condition			Print JOB Enable/Disable
	SIM26-38-A set value	Counter name	Counter value	
Maintenance required. Code: TA	0 (Print continue)	Maintenance counter (Total)	When the SIM21-1 set value is reached.	Enable
	1 (Print stop)		When 90% of the SIM21-1 set value is reached.	
Maintenance required. Code: TA	1 (Print stop)		When the SIM21-1 set value is reached.	Disable
Maintenance required. Code: CA	0 (Print continue)	Maintenance counter (Color)	When the SIM21-1 set value is reached.	Enable
	1 (Print stop)		When 90% of the SIM21-1 set value is reached.	
Maintenance required. Code: CA	1 (Print stop)		When the SIM21-1 set value is reached.	Disable
Maintenance required. Code: AA	0 (Print continue)	Both of total and color	When the SIM21-1 set value is reached.	Enable
	1 (Print stop)		When 90% of the SIM21-1 set value is reached.	
Maintenance required. Code: AA	1 (Print stop)		When the SIM21-1 set value is reached.	Disable

\* After execution of maintenance, be sure to execute SIM24-4 to clear the maintenance counter (Total) and the maintenance counter (Color).

### B. Primary transfer unit

Display content	Display condition			Print JOB Enable/Disable
	SIM26-38-A set value	Counter name	Counter value	
Maintenance required.: TK1	0 (Print continue)	Primary transfer unit print counter	<b>18cpm machine:</b> When 80K is reached.	Enable
	1 (Print stop)		<b>20/23/26/31cpm machine:</b> When 100K is reached. <b>36cpm machine:</b> When 120K is reached.	

\* After execution of the maintenance, execute SIM24-4 to clear the primary transfer unit print counter, the accumulated number of rotations counter, and the use day counter.

### C. Secondary transfer unit

Display content	Display condition			Print JOB Enable/Disable
	SIM26-38-A set value	Counter name	Counter value	
Maintenance required.: TK2	0 (Print continue)	Secondary transfer unit print counter	<b>18cpm machine:</b> When 240K is reached.	Enable
	1 (Print stop)		<b>20/23/26/31cpm machine:</b> When 300K is reached. <b>36cpm machine:</b> When 360K is reached.	

\* After execution of the maintenance, execute SIM24-4 to clear the secondary transfer print counter, the accumulated number of rotations counter, and the use day counter.

### D. Fusing unit

Display content	Display condition				Print JOB Enable/Disable
	SIM26-38-A set value	SIM26-38-B set value	Counter name	Counter value	
Maintenance required.: FK1	0 (Print continue)	–	Fusing roller print counter (18/20cpm machine) Fusing belt print counter (23/26/31/36cpm machine)	<b>18/20/26/31cpm machine: (Excpet North America)</b> When 100K is reached. <b>23cpm machine:</b> When 100K is reached. <b>26/31cpm machine: (North America)</b> When 200K is reached. <b>36cpm machine:</b> When 240K is reached.	Enable
	1 (Print stop)	–			
Maintenance required.: FK2	0 (Print continue)	–	Pressure roller print counter	<b>18/20cpm machine:</b> When 100K is reached. <b>23/26/31cpm machine:</b> When 200K is reached. <b>36cpm machine:</b> When 240K is reached.	Enable
	1 (Print stop)	–			
Maintenance required.: FK3 (36cpm machine only)	–	0 (Print continue)	Fusing web print counter	When 120K is reached.	Enable
Maintenance required.: FK3 (Pop-up) (36cpm machine only)	–	0 (Print continue)	Fusing web print counter	When Web end detection is ON.	Enable
	–	1 (Print stop)			Disable

\* After execution of the maintenance, execute SIM24-4 to clear the fusing roller counter, the fusing belt counter, the fusing web print counter, the accumulated rotation number counter, and the use day counter.

## E. OPC drum

Display content	Display condition			Print JOB Enable/Disable
	SIM26-38-A set value	Counter name	Counter value	
Maintenance required.: DK	0 (Print continue)	OPC drum print counter (K)	<b>18cpm machine:</b> When 80K is reached. <b>20/23/26/31cpm machine:</b> When 100K is reached. <b>36cpm machine:</b> When 120K is reached.	Enable
	1 (Print stop)	OPC drum accumulated rotation number counter (K)	When 840K is reached.	
Maintenance required.: D (C/M/Y)	0 (Print continue)	OPC drum print counter (C/M/Y)	<b>18cpm machine:</b> When 50K is reached. <b>20/23/26/31cpm machine:</b> When 60K is reached. <b>36cpm machine:</b> When 70K is reached.	
	1 (Print stop)	OPC drum accumulated rotation number counter (C/M/Y)	When 840K is reached.	

\* After execution of the maintenance, execute SIM24-4 to clear the OPC drum print counter, the accumulated number of rotations counter, and the use day counter.

## F. Developer

Display content	Display condition			Print JOB Enable/Disable
	SIM26-38-A set value	Counter name	Counter value	
Maintenance required.: VK	0 (Print continue)	Developer print counter (K)	<b>18cpm machine:</b> When 80K is reached. <b>20/23/26/31cpm machine:</b> When 100K is reached. <b>36cpm machine:</b> When 120K is reached.	Enable
	1 (Print stop)	DV unit accumulated number of rotations (K)	When 840K is reached.	
Maintenance required.: V (C/M/Y)	0 (Print continue)	Developer print counter (C/M/Y)	<b>18cpm machine:</b> When 50K is reached. <b>20/23/26/31cpm machine:</b> When 60K is reached. <b>36cpm machine:</b> When 70K is reached.	
	1 (Print stop)	DV unit accumulated number of rotations (C/M/Y)	When 840K is reached.	

\* After execution of the maintenance, execute SIM24-4 to clear the developer print counter, the accumulated number of rotations counter, and the use day counter.

## G. Waste toner box

Display content	Display condition		Print JOB Enable/Disable
	Counter name	Counter value	
Check the waste toner box.	After detection of near end, pixel count 836K (equivalent to color 2K, monochrome 8K print)		Near end: Enable End: Disable

\* When the waste toner box is replaced with an empty one, the message disappears.

## H. Toner

Display content	Display condition			Print JOB Enable/Disable
	SIM26-38-A set value	Counter name	Counter value	
(K/C/M/Y) Prepare a toner (Near near end)	No relation	Toner motor rotation time	Specified time of rotations	Enable
(K/C/M/Y) Toner supply is low (Near end)	No relation	Toner supply amount is decreasing.	ATC sensor output variation	Enable
Replace the toner cartridge. (K) (End)	0 (Print continue)	The pixel count from near end reaches the specified value.	Specified pixel count	(Disable for a JOB which requires K toner)
	1 (Print stop)			
Replace the toner cartridge. (C/M/Y) (End)	0 (Print continue)	The pixel count from near end reaches the specified value.	Specified pixel count	Enable for monochrome, Disable for color
	1 (Print stop)			

### 3. Maintenance list

#### Main unit (18cpm machine)

×: Check (Clean, replace, or adjust according to necessity.) ○: Clean ▲: Replace △: Adjust ☆: Lubricate

Section/Unit work sequence	Name	Unit name	Work sequence	Part name	When calling	80 k	160 k	240 k	320 k	400 k	480 k	Remark	
Monochrome consumable	Developing section	Developing unit (monochrome)	1	Developer	×	▲	▲	▲	▲	▲	▲		
			2	DV seal	×	×	×	×	×	×	×	×	Replace as needed.
			3	DV side seals F/R	×	×	×	×	×	×	×	×	Replace as needed.
			4	Toner filter	×	×	×	×	×	×	×	×	Replace as needed.
			5	Bias pin	×	×	×	×	×	×	×	×	
			6	Connector	×	×	×	×	×	×	×	×	
	OPC drum section	OPC drum unit	1	Drum	×	▲	▲	▲	▲	▲	▲		
			2	Cleaning blade	×	▲	▲	▲	▲	▲	▲		
			3	Toner reception blade	×	▲	▲	▲	▲	▲	▲		
			4	Side seals F/R	×	×	×	×	×	×	×	×	
5			Charger cleaner	×	▲	▲	▲	▲	▲	▲	▲	Integrated as a drum kit.	

Section/Unit work sequence	Name	Unit name	Work sequence	Part name	When calling	50 k	100 k	150 k	200 k	250 k	300 k	Remark	
Color consumable	Developing section	Developing unit (color)	1	Developer	×	▲	▲	▲	▲	▲	▲		
			2	DV seal	×	×	×	×	×	×	×	×	Replace as needed.
			3	DV side seals F/R	×	×	×	×	×	×	×	×	Replace as needed.
			4	Toner filter	×	×	×	×	×	×	×	×	Replace as needed.
			5	Bias pin	×	×	×	×	×	×	×	×	
			6	Connector	×	×	×	×	×	×	×	×	
	OPC drum section	OPC drum unit	1	Drum	×	▲	▲	▲	▲	▲	▲	▲	
			2	Cleaning blade	×	▲	▲	▲	▲	▲	▲	▲	
			3	Toner reception blade	×	▲	▲	▲	▲	▲	▲	▲	
			4	Side seals F/R	×	×	×	×	×	×	×	×	
5			Charger cleaner	×	▲	▲	▲	▲	▲	▲	▲	Integrated as a drum kit.	

Section/Unit work sequence	Name	Unit name	Work sequence	Part name	When calling	80 k	160 k	240 k	320 k	400 k	480 k	Remark	
1	RPSF section	RPSF unit	1	Document pickup roller	○	○	○	○	○	○	○	Replace at 80K of the SPF paper feed counter or 1 year of use. When replacing the paper feed roller, apply grease to the paper feed shaft. GP-501MR (UKOG-0013QSZZ)	
			2	Paper feed roller	○	○	○	○	○	○	○		
			3	Separation roller	○	○	○	○	○	○	○		
			4	Torque limiter SPF	×	×	×	×	×	×	×	×	Replacement reference: Replace referring to the paper feed counter value. SPF section torque limiter: Replace at 400K or 2 years of use.
			5	Take-up torque limiter	×	×	×	×	×	×	×	×	
			6	Discage brush	×	×	×	×	×	×	×	×	
			7	Registration roller	○	○	○	○	○	○	○	○	
			8	Transport roller 2	○	○	○	○	○	○	○	○	
			9	Transport roller 3	○	○	○	○	○	○	○	○	
			10	Paper exit roller	○	○	○	○	○	○	○	○	
			11	Sensors	×	×	×	×	×	×	×	×	
			12	Scan plate	○	○	○	○	○	○	○	○	
			13	Gears	×	×	×	×	×	×	×	×	
			14	Belts	×	×	×	×	×	×	×	×	
			15	OC mat	○	○	○	○	○	○	○	○	
2	Scanner section	Scanner unit	1	Drive belt	×	×	×	×	×	×	×	×	
			2	Drive wire	×	×	×	×	×	×	×	×	
			3	Sensors	×	×	×	×	×	×	×	×	
			4	Rails	☆	☆	☆	☆	☆	☆	☆	☆	
			5	Mirror	○	○	○	○	○	○	○	○	
			6	Reflector	○	○	○	○	○	○	○	○	
			7	Scanner lamp	○	○	○	○	○	○	○	○	
			8	Lens	○	○	○	○	○	○	○	○	
			9	CCD	○	○	○	○	○	○	○	○	
			10	Table glass	○	○	○	○	○	○	○	○	
			11	SPF glass	○	○	○	○	○	○	○	○	

Section/Unit work sequence	Name	Unit name	Work sequence	Part name	When calling	80 k	160 k	240 k	320 k	400 k	480 k	Remark
3	Transfer section	Primary transfer unit	1	Separation pawl	-	×	×	×	×	×	×	Replace as needed.
			2	Primary transfer belt	-	▲	▲	▲	▲	▲	▲	When replacing, apply KYNAR powder.
			3	Secondary drive transmission gear	-	○	○	○	○	○	○	
			4	Primary transfer belt drive roller	-	○	○	○	○	○	○	
			5	Primary transfer belt follower roller	-	○	○	○	○	○	○	
			6	Primary transfer belt tension roller	-	○	○	○	○	○	○	
			7	Registration backup roller	-	○	○	○	○	○	○	
			8	Y auxiliary roller	-	○	○	○	○	○	○	
			9	PTC backup roller	-	○	○	○	○	○	○	
			10	Primary transfer roller	-	×	×	×	×	×	×	Replace as needed.
			11	Transfer cleaner seals F/R	-	×	×	×	×	×	×	Replace as needed.
			12	Primary transfer belt cleaner blade	-	▲	▲	▲	▲	▲	▲	
			13	Primary transfer toner reception blade	-	×	×	×	×	×	×	Replace as needed.
			14	Primary transfer operation mode detector	-	○	○	○	○	○	○	
4	Transfer section	Secondary transfer unit	1	Secondary transfer belt follower roller	-	-	-	○	-	-	○	
			2	Secondary transfer belt	-	-	-	▲	-	-	▲	Never use alcohol or solvents for cleaning..
			3	Secondary transfer belt drive roller	-	-	-	○	-	-	○	
			4	Secondary transfer backup roller	-	-	-	○	-	-	○	
			5	Secondary transfer belt tension roller	-	-	-	○	-	-	○	
			6	Secondary transfer roller	-	-	-	×	-	-	×	Replace as needed.
			7	Secondary transfer drive gear	-	-	-	×	-	-	×	Replace as needed.
			8	Separation cam	-	-	-	☆	-	-	☆	When replacing, apply UKOG-0299FCZZ to the shaft section.
			9	Secondary transfer frame	-	-	-	☆	-	-	☆	When replacing, apply UKOG-0299FCZZ to the shaft section.
5		Other	1	PTC unit	○	▲	▲	▲	▲	▲	▲	
			2	Image density sensor/Registration sensor/ Standard reflection plate	-	○	○	○	○	○	○	Remove dirt from the light emitting/receiving sections (transparent plastic sections) of the sensor and the standard reflection plate (gray plastic section) with dry waste cloth. *1
6	LSU section	LSU	1	Dust-proof glass	○	○	○	○	○	○	○	Use the LSU cleaning rod.
		Other	2	Cleaning base	×	Replace every time the waste toner box is replaced.					Attached to the waste toner box. (2 pcs.) / Replace when the waste toner box is replaced, or at 100K, or 2 years of use.	
7	Manual paper feed section	Manual paper feed unit	1	Paper feed roller	×	○	○	○	○	○	○	Replace at 80K of each paper feed counter or after 2-year use.
			2	Separation roller	×	○	○	○	○	○	○	Replace at 80K of each paper feed counter or after 3-year use.
			3	Torque limiter	×	×	×	×	×	×	×	
			4	Transport roller 9	×	○	○	○	○	○	○	
			5	Sensors	×	×	×	×	×	×	×	
-			-	Paper guides	○	○	○	○	○	○		

Section/Unit work sequence	Name	Unit name	Work sequence	Part name	When calling	80 k	160 k	240 k	320 k	400 k	480 k	Remark	
8	Tray paper feed section	Tray paper feed unit	1	Paper pickup roller	×	○	○	○	○	○	○	Replace at 80K of each paper feed counter or after 1-year use	
			2	Paper feed roller	×	○	○	○	○	○	○	Replace at 80K of each paper feed counter or after 2-year use	
			3	Separation roller	×	○	○	○	○	○	○	Replace at 80K of each paper feed counter or after 3-year use	
			4	Transport roller 4	×	○	○	○	○	○	○		
			5	Transport roller 2	×	○	○	○	○	○	○		
			6	Torque limiter	×	×	×	×	×	×	×	×	
			7	Sensors	×	×	×	×	×	×	×	×	
9	Paper registration section (paper transport section)/ Paper exit section/ ADU section	PS unit	1	Registration roller (Idle)	×	○	○	○	○	○	○		
			2	Registration roller (drive)	×	○	○	○	○	○	○		
			3	Transport roller 5	×	○	○	○	○	○	○		
			4	Sensors									
		Right door unit	5	Transport roller 7	×	○	○	○	○	○	○	○	
			6	Transport roller 8	×	○	○	○	○	○	○	○	
			7	Sensors									
		Fusing rear unit	8	Transport roller 6	×	○	○	○	○	○	○	○	
		Paper exit unit	9	Paper exit roller 1	×	○	○	○	○	○	○	○	
			10	Discharge brush	×	×	×	×	×	×	×	×	
			11	Sensors	×	×	×	×	×	×	×	×	
		Other	12	Paper dust removing unit	○	▲	▲	▲	▲	▲	▲	▲	▲
–	Paper guides		○	○	○	○	○	○	○	○	○		
10	Drive section	Main drive unit	1	Gears (grease)	×	×	×	×	×	×	×	Apply to the specified position when checking. FLOIL G-313S	
			2	Shafts (grease)	×	×	×	×	×	×	×		
			3	Shaft earth sections (conduction grease)	×	×	×	×	×	×	×		Apply to the specified position when checking. FLOIL GE-676
			4	Belts	×	×	×	×	×	×	×		
			5	Sensors	×	×	×	×	×	×	×		×
		Transport drive unit	6	Belts	×	×	×	×	×	×	×	×	Apply to the specified position when checking. HANARL FL-955R
			7	Connection arm	×	×	×	×	×	×	×	×	
		8	Shafts (grease)	×	×	×	×	×	×	×	×		
		Fusing drive unit	9	Shafts (grease)	×	×	×	×	×	×	×	×	
		Paper exit drive unit	10	Shafts (grease)	×	×	×	×	×	×	×	×	
			11	Belts	×	×	×	×	×	×	×	×	
11	Fusing section	Fusing unit	1	Lower separation pawl	×	×	×	×	×	×	×	×	Replace as needed.
			2	Lower separation pawl spring	×	×	×	×	×	×	×	×	Replace as needed.
			3	Separation plate	×	×	×	×	×	×	×	×	Replace as needed.
			4	Oil applying roller	×	▲	▲	▲	▲	▲	▲	▲	
			5	Backup roller	×	▲	▲	▲	▲	▲	▲	▲	
			6	CL roller bearing	×	▲	▲	▲	▲	▲	▲	▲	
			7	Lower thermistor	×	×	×	×	×	×	×	×	Replace as needed.
			8	Pressure roller gear	×	×	×	×	×	×	×	×	Replace as needed.
			9	Pressure roller bearing	×	×	×	×	×	×	×	×	Replace as needed.
			10	Pressure roller	×	▲	▲	▲	▲	▲	▲	▲	Apply grease to the shaft section when replacing. (UKOG-0235FCZZ)
			11	Sub thermistor	×	×	×	×	×	×	×	×	Replace as needed.
			12	Heat-insulating bush	×	×	×	×	×	×	×	×	Replace as needed.
			13	Heating roller bearing	×	×	×	×	×	×	×	×	Replace as needed.
			14	Fusing roller	×	▲	▲	▲	▲	▲	▲	▲	Apply grease to the shaft section when replacing. (UKOG-0235FCZZ)
			15	Main thermistor	×	×	×	×	×	×	×	×	Replace as needed.
			16	Paper guides	○	○	○	○	○	○	○	○	
			17	Gears	×	×	×	×	×	×	×	×	
			18	Lower scraper assembly	×	▲	▲	▲	▲	▲	▲	▲	▲

Section/Unit work sequence	Name	Unit name	Work sequence	Part name	When calling	80 k	160 k	240 k	320 k	400 k	480 k	Remark	
11	Fusing section	Fusing unit	19	Pressure spring									
12	Other		1	Ozone filter	–	▲	▲	▲	▲	▲	▲		
			2	Toner cartridge BK	User replacement for every toner empty.								
			3	Toner cartridge C									
			4	Toner cartridge M									
			5	Toner cartridge Y									
			6	Waste toner box	Replaced by the user when full is detected.								Replacement reference: 50K

\* 1: Note for cleaning the image density sensor, the registration sensor, and the standard reflection plate

When in maintenance or in case of a service call, refer to "Criteria for necessity of cleaning" below to judge the necessity of cleaning the image density sensor, the registration sensor, and the standard reflection plate. If it is judged that cleaning is necessary, then execute cleaning.

#### Criteria for necessity of cleaning

- The SIM44-2 PCS\_CL LED ADJ value is increased by aging and dirt of the image density sensor and the standard reflection plate.
- When the density of an output image is decreased and the difference between the SIM44-2 PCS\_CL LED ADJ value and the SIM44-13 PCS\_CL LED ADJ value is 30 or more, the image density sensor, the registration sensor, and the standard reflection plate may be dirtied.  
In this case, clean the image density sensor, the registration sensor, and the standard reflection plate with dry cloth, and perform calibration with SIM44-13 by using the calibration tool (UKOG-0318FCZZ).  
After completion of cleaning, use SIM46-74 ADJ 10B to adjust the copy/printer color balance.

#### Note

#### Greasing

Greasing is not always required for every maintenance. In the following cases, check and grease.

- When there are some noises.
- When a lot of jams occur frequently. (Check the jam history.)

For the part code of grease to be used, refer to "[15] TOOL LIST."

#### Note

#### Cleaning of sensors and detectors in the paper feed/transport system

Cleaning of sensors and detectors in the paper feed/transport system is not always required for every maintenance. In the following cases, check and clean.

- When a trouble or a jam occurs due to a sensor or a detector. (Check the jam history.)

#### Note

#### Torque limiter check and replacement

Torque limiter check and replacement is not always required for every maintenance. In the following cases, check and replace.

- When there are some noises.
- When a lot of jams occur frequently. (Check the jam history.)

#### Note

#### Alcohol for cleaning

Be sure to use ethanol for cleaning.

#### Note

#### Cleaning of the primary transfer mode detector (CL/BK)

- When replacing the OPC drum, remove the primary transfer unit and the developing unit, and clean them. (Every 100K)
- Blow air to the light emitting section and light receiving section to remove the attached toner.
- Blow air also when the sensor is wiped and cleaned with waste cloth.

**Main unit (20cpm machine)**

X: Check (Clean, replace, or adjust according to necessity.) O: Clean ▲: Replace △: Adjust ☆: Lubricate

Section/ Unit work sequence	Section name	Unit name	Parts work sequence	Part name	When calling	60 K	100 K	120 K	180 K	200 K	240 K	300 K	360 K	400 K	Remark		
1	RSPF section	RSPF unit	1	Document pickup roller	O	-	O	-	-	O	-	O	-	O	Replace at 100K of the SPF paper feed counter or 1 year of use. When replacing the paper feed roller, apply grease to the paper feed shaft. GP-501MR		
			2	Paper feed roller	O	-	O	-	-	O	-	O	-	O		Replace at 400K of the SPF paper feed counter or 2 years of use.	
			3	Separation roller	O	-	O	-	-	O	-	O	-	O			
			4	Torque limiter SPF	X	-	X	-	-	X	-	X	-	X	-	X	Replace at 400K of the SPF paper feed counter or 2 years of use.
			5	Take-up torque limiter	X	-	X	-	-	X	-	X	-	X	-	X	
			6	Discharge brush	X	-	X	-	-	X	-	X	-	X	-	X	
			7	Registration roller	O	-	O	-	-	O	-	O	-	O	-	O	
			8	Transport roller 2	O	-	O	-	-	O	-	O	-	O	-	O	
			9	Transport roller 3	O	-	O	-	-	O	-	O	-	O	-	O	
			10	Paper exit roller	O	-	O	-	-	O	-	O	-	O	-	O	
			11	Sensors	X	-	X	-	-	X	-	X	-	X	-	X	
			12	Scan plate	O	-	O	-	-	O	-	O	-	O	-	O	
			13	Gears	X	-	X	-	-	X	-	X	-	X	-	X	
			14	Belts	X	-	X	-	-	X	-	X	-	X	-	X	
			15	OC mat	O	-	O	-	-	O	-	O	-	O	-	O	
2	Scanner section	Scanner unit	1	Drive belt	X	-	X	-	-	X	-	X	-	X			
			2	Drive wire	X	-	X	-	-	X	-	X	-	X	-	X	
			3	Sensors	X	-	X	-	-	X	-	X	-	X	-	X	
			4	Rails	☆	-	☆	-	-	☆	-	☆	-	☆	-	☆	
			5	Mirror	O	-	O	-	-	O	-	O	-	O	-	O	
			6	Reflector	O	-	O	-	-	O	-	O	-	O	-	O	
			7	Scanner lamp	O	-	O	-	-	O	-	O	-	O	-	O	
			8	Lens	O	-	O	-	-	O	-	O	-	O	-	O	
			9	CCD	O	-	O	-	-	O	-	O	-	O	-	O	
			10	Table glass	O	-	O	-	-	O	-	O	-	O	-	O	
			11	SPF glass	O	-	O	-	-	O	-	O	-	O	-	O	
3	Developing section	Developing unit (monochrome)	1	Developer	X	-	▲	-	-	▲	-	▲	-	▲	Replace as needed.		
			2	DV seal	X	-	X	-	-	X	-	X	-	X			
			3	DV side seals F/R	X	-	X	-	-	X	-	X	-	X			
			4	Toner filter	X	-	X	-	-	X	-	X	-	X	-	X	
			5	Bias pin	X	-	X	-	-	X	-	X	-	X	-	X	
			6	Connector	X	-	X	-	-	X	-	X	-	X	-	X	
		Developing unit (color)	1	Developer	X	▲	-	▲	▲	-	▲	▲	▲	-	▲	Replace as needed.	
			2	DV seal	X	X	-	X	X	-	X	X	X	-	X		
			3	DV side seals F/R	X	X	-	X	X	-	X	X	X	-	X		
			4	Toner filter	X	X	-	X	X	-	X	X	X	-	X	-	X
			5	Bias pin	X	X	-	X	X	-	X	X	X	-	X	-	X
			6	Connector	X	X	-	X	X	-	X	X	X	-	X	-	X
4	OPC drum section	OPC drum unit (monochrome)	1	Drum	X	-	▲	-	-	▲	-	▲	-	▲	Integrated as a drum kit (Common to monochrome and color)		
			2	MC unit	X	-	▲	-	-	▲	-	▲	-	▲		Replace as needed.	
			3	Cleaning blade	X	-	▲	-	-	▲	-	▲	-	▲			
			4	Toner reception blade	X	-	X	-	-	X	-	X	-	X	-	X	Replace as needed.
			5	Side seals F/R	X	-	X	-	-	X	-	X	-	X	-	X	
			6	Charger cleaner	X	-	▲	-	-	▲	-	▲	-	▲	-	▲	



Section/ Unit work sequence	Section name	Unit name	Parts work sequence	Part name	When calling	60 K	100 K	120 K	180 K	200 K	240 K	300 K	360 K	400 K	Remark	
4	OPC drum section	OPC drum unit (color)	1	Drum	×	▲	–	▲	▲	–	▲	▲	▲	–	Integrated as a drum kit (Common to monochrome and color)	
			2	MC unit	×	▲	–	▲	▲	–	▲	▲	▲	–		
			3	Cleaning blade	×	▲	–	▲	▲	–	▲	▲	▲	–		
			4	Toner reception blade	×	×	–	×	×	–	×	×	×	×	–	Replace as needed.
			5	Side seals F/R	×	×	–	×	×	–	×	×	×	×	–	
			6	Charger cleaner	×	▲	–	▲	▲	–	▲	▲	▲	▲	–	Integrated as a drum kit (Common to monochrome and color)
5	Transfer section	Primary transfer unit	1	Separation pawl	×	–	×	–	–	×	–	×	–	×	Replace as needed.	
			2	Primary transfer belt	×	–	▲	–	–	▲	–	▲	–	▲	When replacing, apply KYNAR powder.	
			3	Secondary drive transmission gear	×	–	○	–	–	○	–	○	–	○		
			4	Primary transfer belt drive roller	×	–	○	–	–	○	–	○	–	○		
			5	Primary transfer belt follower roller	×	–	○	–	–	○	–	○	–	○		
			6	Primary transfer belt tension roller	×	–	○	–	–	○	–	○	–	○		
			7	Registration backup roller	×	–	○	–	–	○	–	○	–	○		
			8	Y auxiliary roller	×	–	○	–	–	○	–	○	–	○		
			9	PTC backup roller	×	–	○	–	–	○	–	○	–	○		
			10	Primary transfer roller	×	–	×	–	–	×	–	×	–	×	Replace as needed.	
			11	Transfer cleaner seals F/R	×	–	×	–	–	×	–	×	–	×		
			12	Primary transfer belt cleaner blade	×	–	▲	–	–	▲	–	▲	–	▲		
			13	Primary transfer toner reception blade	×	–	×	–	–	×	–	×	–	×	Replace as needed.	
			14	Primary transfer operation mode detector	×	–	○	–	–	○	–	○	–	○		
6	Transfer section	Secondary transfer unit	1	Secondary transfer belt follower roller	×	–	–	–	–	–	–	○	–	–		
			2	Secondary transfer belt	×	–	–	–	–	–	–	–	▲	–	–	Never use alcohol or solvents for cleaning. Replace at every 300K.
			3	Secondary transfer belt drive roller	×	–	–	–	–	–	–	–	○	–	–	
			4	Secondary transfer backup roller	×	–	–	–	–	–	–	–	○	–	–	
			5	Secondary transfer belt tension roller	×	–	–	–	–	–	–	–	○	–	–	
			6	Secondary transfer roller	×	–	–	–	–	–	–	–	×	–	–	Replace as needed.
			7	Secondary transfer drive gear	×	–	–	–	–	–	–	–	×	–	–	

Section/ Unit work sequence	Section name	Unit name	Parts work sequence	Part name	When calling	60 K	100 K	120 K	180 K	200 K	240 K	300 K	360 K	400 K	Remark	
6	Transfer section	Secondary transfer unit	8	Separation cam	×	-	-	-	-	-	-	☆	-	-	When replacing, apply HANARL FL-955R to the shaft section.	
			9	Secondary transfer frame	×	-	-	-	-	-	-	-	☆	-		-
7		Other	1	PTC unit	×	○	▲	○	○	▲	○	▲	○	▲		
			2	Image density sensor/ Registration sensor/ Standard reflection plate	×	-	○	-	-	○	-	○	-	○	-	○
8	LSU section	LSU	1	Dust-proof glass	○	-	○	-	-	○	-	○	-	○	Use the LSU cleaning rod.	
		Other	2	Cleaning base	×	Replace every time the waste toner box is replaced.									Attached to the waste toner box. (2 pcs.) / Replace when the waste toner box is replaced, or at 100K, or 2 years of use.	
9	Manual paper feed section	Manual paper feed unit	1	Paper feed roller	×	-	○	-	-	○	-	○	-	○	Replace at 100K of the manual paper feed counter or 1 year of use.	
			2	Separation roller	×	-	○	-	-	○	-	○	-	○		
			3	Torque limiter	×	-	×	-	-	×	-	×	-	×	-	
			4	Transport roller 9	×	-	○	-	-	○	-	○	-	○	-	○
			5	Sensors	×	-	×	-	-	×	-	×	-	×	-	×
-	Paper guides	○	-	○	-	-	○	-	○	-	○	-	○	Clean with alcohol.		
10	Tray paper feed section	Tray paper feed unit	1	Paper pickup roller	×	-	○	-	-	○	-	○	-	○	Replace at 100K of the tray paper feed counter or 1 year of use.	
			2	Paper feed roller	×	-	○	-	-	○	-	○	-	○		
			3	Separation roller	×	-	○	-	-	○	-	○	-	○	-	○
			4	Transport roller 4	×	-	○	-	-	○	-	○	-	○	-	○
			5	Transport roller 2	×	-	○	-	-	○	-	○	-	○	-	○
			6	Torque limiter	×	-	×	-	-	×	-	×	-	×	-	×
			7	Sensors	×	-	×	-	-	×	-	×	-	×	-	×
			-	Paper guides	○	-	○	-	-	○	-	○	-	○	-	○
11	Paper registration section (paper transport section)/ Paper exit section/ ADU section	PS unit	1	Registration roller (idle)	×	-	○	-	-	○	-	○	-	○		
			2	Registration roller (drive)	×	-	○	-	-	○	-	○	-	○		
			3	Transport roller 5	×	-	○	-	-	○	-	○	-	○		
			4	Sensors	×	-	×	-	-	×	-	×	-	×	-	×
		Right door unit	5	Transport roller 7	×	-	○	-	-	○	-	○	-	○	-	○
			6	Transport roller 8	×	-	○	-	-	○	-	○	-	○	-	○
			7	Paper exit roller 2	×	-	○	-	-	○	-	○	-	○	-	○
			8	Discharge brush	×	-	×	-	-	×	-	×	-	×	-	×
			9	Sensors	×	-	×	-	-	×	-	×	-	×	-	×
		Fusing rear unit	10	Transport roller 6	×	-	○	-	-	○	-	○	-	○	-	○
		Paper exit unit	11	Paper exit roller 1	×	-	○	-	-	○	-	○	-	○	-	○
			12	Discharge brush	×	-	×	-	-	×	-	×	-	×	-	×
			13	Sensors	×	-	×	-	-	×	-	×	-	×	-	×
		Other	14	Paper dust removing unit	○	-	▲	-	-	▲	-	▲	-	▲	-	▲
-	Paper guides	○	-	○	-	-	○	-	○	-	○	-	○	Clean with alcohol.		

Section/ Unit work sequence	Section name	Unit name	Parts work sequence	Part name	When calling	60 K	100 K	120 K	180 K	200 K	240 K	300 K	360 K	400 K	Remark		
12	Drive section	Main drive unit	1	Gears (grease)	×	-	×	-	-	×	-	×	-	×	Apply to the specified position when checking. FLOIL G-313S		
			2	Shafts (grease)	×	-	×	-	-	×	-	×	-	×			
			3	Shaft earth sections (conduction grease)	×	-	×	-	-	×	-	×	-	×	×	Apply to the specified position when checking. FLOIL GE-676	
			4	Belts	×	-	×	-	-	×	-	×	-	×	×		
			5	Sensors	×	-	×	-	-	×	-	×	-	×	×		
		7	Transport drive unit	Connection arm	×	-	×	-	-	×	-	×	-	×	×	Apply to the specified position when checking. HANARL FL-955R	
		8	Fusing drive unit	Shafts (grease)	×	-	×	-	-	×	-	×	-	×	×		
		Paper exit drive unit	9	Shafts (grease)	×	-	×	-	-	×	-	×	-	×			
13	Fusing section	Fusing unit	1	Lower separation pawl	×	-	×	-	-	×	-	×	-	×	Replace as needed.		
			2	Lower separation pawl spring	×	-	×	-	-	×	-	×	-	×		×	
			3	Separation plate	×	-	×	-	-	×	-	×	-	×		×	
			4	Oil applying roller	×	-	▲	-	-	▲	-	▲	-	▲	▲		
			5	Backup roller	×	-	▲	-	-	▲	-	▲	-	▲	▲		
			6	CL roller bearing	×	-	▲	-	-	▲	-	▲	-	▲	▲		
			7	Lower thermistor	×	-	×	-	-	×	-	×	-	×	-	×	Replace as needed.
			8	Pressure roller gear	×	-	×	-	-	×	-	×	-	×	-	×	
			9	Pressure roller bearing	×	-	×	-	-	×	-	×	-	×	-	×	
			10	Pressure roller	×	-	×	-	-	▲	-	×	-	▲	-	▲	Apply grease to the shaft section when replacing. (JEF552) / After completion of replacement, clean the new pressure roller surface with alcohol. / Integrated with the fusing roller as a maintenance kit.
			11	Sub thermistor	×	-	×	-	-	×	-	×	-	×	-	×	Replace as needed.
			12	Heat- insulating bush	×	-	×	-	-	×	-	×	-	×	-	×	Replace as needed. / When replacing, apply grease to the inner ring section and the outer ring section. (JEF552)
			13	Heating roller bearing	×	-	×	-	-	×	-	×	-	×	-	×	Replace as needed.
			14	Fusing roller	×	-	×	-	-	▲	-	×	-	▲	-	▲	Apply grease to the shaft section when replacing. (JEF552) / Integrated with the pressure roller as a maintenance kit.
			15	Main thermistor	×	-	×	-	-	×	-	×	-	×	-	×	Replace as needed.
			16	Paper guides	○	-	○	-	-	○	-	○	-	○	-	○	
			17	Gears	×	-	×	-	-	×	-	×	-	×	-	×	Replace as needed.
			18	Lower scraper assembly	×	-	▲	-	-	▲	-	▲	-	▲	-	▲	
			19	Pressure spring	×	-	×	-	-	×	-	×	-	×	-	×	

Section/ Unit work sequence	Section name	Unit name	Parts work sequence	Part name	When calling	60 K	100 K	120 K	180 K	200 K	240 K	300 K	360 K	400 K	Remark
14	Other		1	Ozone filter	—	—	▲	—	—	▲	—	▲	—	▲	
			2	Toner cartridge BK	User replacement for every toner empty.										
			3	Toner cartridge C											
			4	Toner cartridge M											
			5	Toner cartridge Y											
			6	Waste toner box	Replaced by the user when full is detected.										

\* 1: Note for cleaning the image density sensor, the registration sensor, and the standard reflection plate

When in maintenance or in case of a service call, refer to "Criteria for necessity of cleaning" below to judge the necessity of cleaning the image density sensor, the registration sensor, and the standard reflection plate. If it is judged that cleaning is necessary, then execute cleaning.

#### Criteria for necessity of cleaning

- The SIM44-2 PCS\_CL LED ADJ value is increased by aging and dirt of the image density sensor and the standard reflection plate.
- When the density of an output image is decreased and the difference between the SIM44-2 PCS\_CL LED ADJ value and the SIM44-13 PCS\_CL LED ADJ value is 30 or more, the image density sensor, the registration sensor, and the standard reflection plate may be dirtied.  
In this case, clean the image density sensor, the registration sensor, and the standard reflection plate with dry cloth, and perform calibration with SIM44-13 by using the calibration tool (UKOG-0318FCZZ).  
After completion of cleaning, use SIM46-74 ADJ 10B to adjust the copy/printer color balance.

#### Note

##### Greasing

Greasing is not always required for every maintenance. In the following cases, check and grease.

- When there are some noises.
  - When a lot of jams occur frequently. (Check the jam history.)
- For the part code of grease to be used, refer to "[15] TOOL LIST."

#### Note

##### Cleaning of sensors and detectors in the paper feed/transport system

Cleaning of sensors and detectors in the paper feed/transport system is not always required for every maintenance. In the following cases, check and clean.

- When a trouble or a jam occurs due to a sensor or a detector. (Check the jam history.)

#### Note

##### Torque limiter check and replacement

Torque limiter check and replacement is not always required for every maintenance. In the following cases, check and replace.

- When there are some noises.
- When a lot of jams occur frequently. (Check the jam history.)

#### Note

##### Alcohol for cleaning

Be sure to use ethanol for cleaning.

#### Note

##### Cleaning of the primary transfer mode detector (CL/BK)

- When replacing the OPC drum, remove the primary transfer unit and the developing unit, and clean them. (Every 100K)
- Blow air to the light emitting section and light receiving section to remove the attached toner.
- Blow air also when the sensor is wiped and cleaned with waste cloth.

**Main unit (23cpm machine)**

X: Check (Clean, replace, or adjust according to necessity.) O: Clean ▲: Replace △: Adjust ☆: Lubricate

Section/ Unit work sequence	Section name	Unit name	Parts work sequence	Part name	When calling	60 K	100 K	120 K	180 K	200 K	240 K	300 K	360 K	400 K	Remark		
1	RSPF section	RSPF unit	1	Document pickup roller	O	-	O	-	-	O	-	O	-	O	Replace at 100K of the SPF paper feed counter or 1 year of use. When replacing the paper feed roller, apply grease to the paper feed shaft. GP-501MR		
			2	Paper feed roller	O	-	O	-	-	O	-	O	-	O		Replace at 400K of the SPF paper feed counter or 2 years of use.	
			3	Separation roller	O	-	O	-	-	O	-	O	-	O			
			4	Torque limiter SPF	X	-	X	-	-	X	-	X	-	X	-	X	Replace at 400K of the SPF paper feed counter or 2 years of use.
			5	Take-up torque limiter	X	-	X	-	-	X	-	X	-	X	-	X	
			6	Discharge brush	X	-	X	-	-	X	-	X	-	X	-	X	
			7	Registration roller	O	-	O	-	-	O	-	O	-	O	-	O	
			8	Transport roller 2	O	-	O	-	-	O	-	O	-	O	-	O	
			9	Transport roller 3	O	-	O	-	-	O	-	O	-	O	-	O	
			10	Paper exit roller	O	-	O	-	-	O	-	O	-	O	-	O	
			11	Sensors	X	-	X	-	-	X	-	X	-	X	-	X	
			12	Scan plate	O	-	O	-	-	O	-	O	-	O	-	O	
			13	Gears	X	-	X	-	-	X	-	X	-	X	-	X	
			14	Belts	X	-	X	-	-	X	-	X	-	X	-	X	
			15	OC mat	O	-	O	-	-	O	-	O	-	O	-	O	
2	Scanner section	Scanner unit	1	Drive belt	X	-	X	-	-	X	-	X	-	X			
			2	Drive wire	X	-	X	-	-	X	-	X	-	X	-	X	
			3	Sensors	X	-	X	-	-	X	-	X	-	X	-	X	
			4	Rails	☆	-	☆	-	-	☆	-	☆	-	☆	-	☆	
			5	Mirror	O	-	O	-	-	O	-	O	-	O	-	O	
			6	Reflector	O	-	O	-	-	O	-	O	-	O	-	O	
			7	Scanner lamp	O	-	O	-	-	O	-	O	-	O	-	O	
			8	Lens	O	-	O	-	-	O	-	O	-	O	-	O	
			9	CCD	O	-	O	-	-	O	-	O	-	O	-	O	
			10	Table glass	O	-	O	-	-	O	-	O	-	O	-	O	
			11	SPF glass	O	-	O	-	-	O	-	O	-	O	-	O	
3	Developing section	Developing unit (monochrome)	1	Developer	X	-	▲	-	-	▲	-	▲	-	▲	Replace as needed.		
			2	DV seal	X	-	X	-	-	X	-	X	-	X		Replace as needed.	
			3	DV side seals F/R	X	-	X	-	-	X	-	X	-	X			
			4	Toner filter	X	-	X	-	-	X	-	X	-	X	-	X	
			5	Bias pin	X	-	X	-	-	X	-	X	-	X	-	X	
			6	Connector	X	-	X	-	-	X	-	X	-	X	-	X	
		Developing unit (color)	1	Developer	X	▲	-	▲	▲	-	▲	▲	▲	-	▲	Replace as needed.	
			2	DV seal	X	X	-	X	X	-	X	X	X	-	X		Replace as needed.
			3	DV side seals F/R	X	X	-	X	X	-	X	X	X	-	X		
			4	Toner filter	X	X	-	X	X	-	X	X	X	-	X	-	X
			5	Bias pin	X	X	-	X	X	-	X	X	X	-	X	-	X
			6	Connector	X	X	-	X	X	-	X	X	X	-	X	-	X
4	OPC drum section	OPC drum unit (monochrome)	1	Drum	X	-	▲	-	-	▲	-	▲	-	▲	Integrated as a drum kit (Common to monochrome and color)		
			2	MC unit	X	-	▲	-	-	▲	-	▲	-	▲			
			3	Cleaning blade	X	-	▲	-	-	▲	-	▲	-	▲	-	▲	
		4	Toner reception blade	X	-	X	-	-	X	-	X	-	X	-	X	Replace as needed.	
		5	Side seals F/R	X	-	X	-	-	X	-	X	-	X	-	X		
		6	Charger cleaner	X	-	▲	-	-	▲	-	▲	-	▲	-	▲	Integrated as a drum kit (Common to monochrome and color)	

Section/ Unit work sequence	Section name	Unit name	Parts work sequence	Part name	When calling	60 K	100 K	120 K	180 K	200 K	240 K	300 K	360 K	400 K	Remark	
4	OPC drum section	OPC drum unit (color)	1	Drum	×	▲	–	▲	▲	–	▲	▲	▲	–	Integrated as a drum kit (Common to monochrome and color)	
			2	MC unit	×	▲	–	▲	▲	–	▲	▲	▲	–		
			3	Cleaning blade	×	▲	–	▲	▲	–	▲	▲	▲	–		
			4	Toner reception blade	×	×	–	×	×	–	×	×	×	×	–	Replace as needed.
			5	Side seals F/R	×	×	–	×	×	–	×	×	×	×	–	
			6	Charger cleaner	×	▲	–	▲	▲	–	▲	▲	▲	▲	–	Integrated as a drum kit (Common to monochrome and color)
5	Transfer section	Primary transfer unit	1	Separation pawl	×	–	×	–	–	×	–	×	–	×	Replace as needed.	
			2	Primary transfer belt	×	–	▲	–	–	▲	–	▲	–	▲	When replacing, apply KYNAR powder.	
			3	Secondary drive transmission gear	×	–	○	–	–	○	–	○	–	○		
			4	Primary transfer belt drive roller	×	–	○	–	–	○	–	○	–	○		
			5	Primary transfer belt follower roller	×	–	○	–	–	○	–	○	–	○		
			6	Primary transfer belt tension roller	×	–	○	–	–	○	–	○	–	○		
			7	Registration backup roller	×	–	○	–	–	○	–	○	–	○		
			8	Y auxiliary roller	×	–	○	–	–	○	–	○	–	○		
			9	PTC backup roller	×	–	○	–	–	○	–	○	–	○		
			10	Primary transfer roller	×	–	×	–	–	×	–	×	–	×	Replace as needed.	
			11	Transfer cleaner seals F/R	×	–	×	–	–	×	–	×	–	×		
			12	Primary transfer belt cleaner blade	×	–	▲	–	–	▲	–	▲	–	▲		
			13	Primary transfer toner reception blade	×	–	×	–	–	×	–	×	–	×	Replace as needed.	
			14	Primary transfer operation mode detector	×	–	○	–	–	○	–	○	–	○		
6	Transfer section	Secondary transfer unit	1	Secondary transfer belt follower roller	×	–	–	–	–	–	–	○	–	–		
			2	Secondary transfer belt	×	–	–	–	–	–	–	–	▲	–	–	Never use alcohol or solvents for cleaning. Replace at every 300K.
			3	Secondary transfer belt drive roller	×	–	–	–	–	–	–	–	○	–	–	
			4	Secondary transfer backup roller	×	–	–	–	–	–	–	–	○	–	–	
			5	Secondary transfer belt tension roller	×	–	–	–	–	–	–	–	○	–	–	
			6	Secondary transfer roller	×	–	–	–	–	–	–	–	×	–	–	Replace as needed.
			7	Secondary transfer drive gear	×	–	–	–	–	–	–	–	×	–	–	

Section/ Unit work sequence	Section name	Unit name	Parts work sequence	Part name	When calling	60 K	100 K	120 K	180 K	200 K	240 K	300 K	360 K	400 K	Remark
6	Transfer section	Secondary transfer unit	8	Separation cam	×	-	-	-	-	-	-	☆	-	-	When replacing, apply HANARL FL-955R to the shaft section.
			9	Secondary transfer frame	×	-	-	-	-	-	-	-	☆	-	
7		Other	1	PTC unit	×	○	▲	○	○	▲	○	▲	○	▲	
			2	Image density sensor/ Registration sensor/ Standard reflection plate	×	-	○	-	-	○	-	○	-	-	○
8	LSU section	LSU	1	Dust-proof glass	○	-	○	-	-	○	-	○	-	○	Use the LSU cleaning rod.
		Other	2	Cleaning base	×	Replace every time the waste toner box is replaced.									Attached to the waste toner box. (2 pcs.) / Replace when the waste toner box is replaced, or at 100K, or 2 years of use.
9	Manual paper feed section	Manual paper feed unit	1	Paper feed roller	×	-	○	-	-	○	-	○	-	○	Replace at 100K of the manual paper feed counter or 1 year of use.
			2	Separation roller	×	-	○	-	-	○	-	○	-	○	
			3	Torque limiter	×	-	×	-	-	×	-	×	-	×	
			4	Transport roller 9	×	-	○	-	-	○	-	○	-	○	
			5	Sensors	×	-	×	-	-	×	-	×	-	×	
			-	Paper guides	○	-	○	-	-	○	-	○	-	○	Clean with alcohol.
10	Tray paper feed section	Tray paper feed unit	1	Paper pickup roller	×	-	○	-	-	○	-	○	-	○	Replace at 100K of the tray paper feed counter or 1 year of use.
			2	Paper feed roller	×	-	○	-	-	○	-	○	-	○	
			3	Separation roller	×	-	○	-	-	○	-	○	-	○	
			4	Transport roller 4	×	-	○	-	-	○	-	○	-	○	
			5	Transport roller 2	×	-	○	-	-	○	-	○	-	○	
			6	Torque limiter	×	-	×	-	-	×	-	×	-	×	
			7	Sensors	×	-	×	-	-	×	-	×	-	×	
						-	Paper guides	○	-	○	-	-	○	-	○
11	Paper registration section (paper transport section)/ Paper exit section/ ADU section	PS unit	1	Registration roller (idle)	×	-	○	-	-	○	-	○	-	○	
			2	Registration roller (drive)	×	-	○	-	-	○	-	○	-	○	
			3	Transport roller 5	×	-	○	-	-	○	-	○	-	○	
			4	Sensors	×	-	×	-	-	×	-	×	-	×	
		Right door unit	5	Transport roller 7	×	-	○	-	-	○	-	○	-	○	
			6	Transport roller 8	×	-	○	-	-	○	-	○	-	○	
			7	Paper exit roller 2	×	-	○	-	-	○	-	○	-	○	
			8	Discharge brush	×	-	×	-	-	×	-	×	-	×	
			9	Sensors	×	-	×	-	-	×	-	×	-	×	
		Fusing rear unit	10	Transport roller 6	×	-	○	-	-	○	-	○	-	○	
		Paper exit unit	11	Paper exit roller 1	×	-	○	-	-	○	-	○	-	○	
			12	Discharge brush	×	-	×	-	-	×	-	×	-	×	
			13	Sensors	×	-	×	-	-	×	-	×	-	×	
		Other	14	Paper dust removing unit	○	-	▲	-	-	▲	-	▲	-	▲	
			-	Paper guides	○	-	○	-	-	○	-	○	-	○	Clean with alcohol.

Section/ Unit work sequence	Section name	Unit name	Parts work sequence	Part name	When calling	60 K	100 K	120 K	180 K	200 K	240 K	300 K	360 K	400 K	Remark	
12	Drive section	Main drive unit	1	Gears (grease)	×	-	×	-	-	×	-	×	-	×	Apply to the specified position when checking. FLOIL G-313S	
			2	Shafts (grease)	×	-	×	-	-	×	-	×	-	×		
			3	Shaft earth sections (conduction grease)	×	-	×	-	-	×	-	×	-	-	×	Apply to the specified position when checking. FLOIL GE-676
			4	Belts	×	-	×	-	-	×	-	×	-	-	×	
			5	Sensors	×	-	×	-	-	×	-	×	-	-	×	
		Transport drive unit	6	Belts	×	-	×	-	-	×	-	×	-	-	×	
			7	Connection arm	×	-	×	-	-	×	-	×	-	-	×	Apply to the specified position when checking. HANARL FL-955R
		Fusing drive unit	8	Shafts (grease)	×	-	×	-	-	×	-	×	-	-	×	
		Paper exit drive unit	9	Shafts (grease)	×	-	×	-	-	×	-	×	-	-	×	
			10	Belts	×	-	×	-	-	×	-	×	-	-	×	
13	Fusing section	Fusing unit	1	Lower separation pawl	×	-	×	-	-	×	-	×	-	×	Replace as needed.	
			2	Lower separation pawl spring	×	-	×	-	-	×	-	×	-	×		
			3	Separation plate	×	-	×	-	-	×	-	×	-	×		
			4	Oil applying roller	×	-	▲	-	-	▲	-	▲	-	▲	▲	
			5	Backup roller	×	-	▲	-	-	▲	-	▲	-	▲	▲	
			6	CL roller bearing	×	-	▲	-	-	▲	-	▲	-	▲	▲	
			7	Lower thermistor	×	-	×	-	-	×	-	×	-	-	×	Replace as needed.
			8	Pressure roller gear	×	-	×	-	-	×	-	×	-	-	×	
			9	Pressure roller bearing	×	-	×	-	-	×	-	×	-	-	×	
			10	Pressure roller	×	-	×	-	-	▲	-	×	-	-	▲	Apply grease to the shaft section when replacing. (JEF552) / After completion of replacement, clean the new pressure roller surface with alcohol. / Integrated with the fusing roller as a maintenance kit.
			11	Sub thermistor	×	-	×	-	-	×	-	×	-	-	×	Replace as needed.
			12	Fusing roller bearing	×	-	×	-	-	×	-	×	-	-	×	
			13	Heat- insulating bush	×	-	×	-	-	×	-	×	-	-	×	Replace as needed. / When replacing, apply grease to the inner ring section and the outer ring section. (JEF552)
			14	Heating roller bearing	×	-	×	-	-	×	-	×	-	-	×	Replace as needed.
			15	Fuser belt guide collar	×	-	▲	-	-	▲	-	▲	-	-	▲	Integrated with the fusing belt as a maintenance kit.
			16	Fusing roller	×	-	×	-	-	▲	-	×	-	-	▲	Apply grease to the shaft section when replacing. (JEF552) / Integrated with the pressure roller as a maintenance kit.
			17	Heating roller	×	-	×	-	-	×	-	×	-	-	×	Replace as needed.
			18	Fusing belt (Except North America)	×	-	▲	-	-	▲	-	▲	-	-	▲	Integrated with the fuser belt guide collar as a maintenance kit. / When replacing, clean the fusing belt surface with alcohol.
			19	Main thermistor	×	-	×	-	-	×	-	×	-	-	×	Replace as needed.
			20	Paper guides	○	-	○	-	-	○	-	○	-	-	○	
			21	Gears	×	-	×	-	-	×	-	×	-	-	×	Replace as needed.



Section/ Unit work sequence	Section name	Unit name	Parts work sequence	Part name	When calling	60 K	100 K	120 K	180 K	200 K	240 K	300 K	360 K	400 K	Remark
13	Fusing section	Fusing unit	22	Lower scraper assembly	×	–	▲	–	–	▲	–	▲	–	▲	
			23	Pressure spring	×	–	×	–	–	×	–	×	–	×	
			24	Washer	×	–	×	–	–	×	–	×	–	×	
14	Other		1	Ozone filter	–	–	▲	–	–	▲	–	▲	–	▲	
			2	Toner cartridge BK	User replacement for every toner empty.										
			3	Toner cartridge C											
			4	Toner cartridge M											
			5	Toner cartridge Y											
			6	Waste toner box	Replaced by the user when full is detected.										

\* 1: Note for cleaning the image density sensor, the registration sensor, and the standard reflection plate

When in maintenance or in case of a service call, refer to "Criteria for necessity of cleaning" below to judge the necessity of cleaning the image density sensor, the registration sensor, and the standard reflection plate. If it is judged that cleaning is necessary, then execute cleaning.

#### Criteria for necessity of cleaning

- The SIM44-2 PCS\_CL LED ADJ value is increased by aging and dirt of the image density sensor and the standard reflection plate.
- When the density of an output image is decreased and the difference between the SIM44-2 PCS\_CL LED ADJ value and the SIM44-13 PCS\_CL LED ADJ value is 30 or more, the image density sensor, the registration sensor, and the standard reflection plate may be dirtied.  
In this case, clean the image density sensor, the registration sensor, and the standard reflection plate with dry cloth, and perform calibration with SIM44-13 by using the calibration tool (UKOG-0318FCZZ).  
After completion of cleaning, use SIM46-74 ADJ 10B to adjust the copy/printer color balance.

#### Note

#### Greasing

Greasing is not always required for every maintenance. In the following cases, check and grease.

- When there are some noises.
- When a lot of jams occur frequently. (Check the jam history.)

For the part code of grease to be used, refer to "[15] TOOL LIST."

#### Note

#### Cleaning of sensors and detectors in the paper feed/transport system

Cleaning of sensors and detectors in the paper feed/transport system is not always required for every maintenance. In the following cases, check and clean.

- When a trouble or a jam occurs due to a sensor or a detector. (Check the jam history.)

#### Note

#### Torque limiter check and replacement

Torque limiter check and replacement is not always required for every maintenance. In the following cases, check and replace.

- When there are some noises.
- When a lot of jams occur frequently. (Check the jam history.)

#### Note

#### Alcohol for cleaning

Be sure to use ethanol for cleaning.

#### Note

#### Cleaning of the primary transfer mode detector (CL/BK)

- When replacing the OPC drum, remove the primary transfer unit and the developing unit, and clean them. (Every 100K)
- Blow air to the light emitting section and light receiving section to remove the attached toner.
- Blow air also when the sensor is wiped and cleaned with waste cloth.

**Main unit (26cpm/31cpm machine)**

X: Check (Clean, replace, or adjust according to necessity.) O: Clean ▲: Replace △: Adjust ☆: Lubricate

Section/ Unit work sequence	Section name	Unit name	Parts work sequence	Part name	When calling	60 K	100 K	120 K	180 K	200 K	240 K	300 K	360 K	400 K	Remark		
1	RSPF section	RSPF unit	1	Document pickup roller	O	-	O	-	-	O	-	O	-	O	Replace at 100K of the SPF paper feed counter or 1 year of use. When replacing the paper feed roller, apply grease to the paper feed shaft. GP-501MR		
			2	Paper feed roller	O	-	O	-	-	O	-	O	-	O			
			3	Separation roller	O	-	O	-	-	O	-	O	-	O			
			4	Torque limiter SPF	X	-	X	-	-	X	-	X	-	X	-	X	Replace at 400K of the SPF paper feed counter or 2 years of use.
			5	Take-up torque limiter	X	-	X	-	-	X	-	X	-	X	-	X	
			6	Discharge brush	X	-	X	-	-	X	-	X	-	X	-	X	
			7	Registration roller	O	-	O	-	-	O	-	O	-	O	-	O	
			8	Transport roller 2	O	-	O	-	-	O	-	O	-	O	-	O	
			9	Transport roller 3	O	-	O	-	-	O	-	O	-	O	-	O	
			10	Paper exit roller	O	-	O	-	-	O	-	O	-	O	-	O	
			11	Sensors	X	-	X	-	-	X	-	X	-	X	-	X	
			12	Scan plate	O	-	O	-	-	O	-	O	-	O	-	O	
			13	Gears	X	-	X	-	-	X	-	X	-	X	-	X	
			14	Belts	X	-	X	-	-	X	-	X	-	X	-	X	
			15	OC mat	O	-	O	-	-	O	-	O	-	O	-	O	
2	Scanner section	Scanner unit	1	Drive belt	X	-	X	-	-	X	-	X	-	X			
			2	Drive wire	X	-	X	-	-	X	-	X	-	X	-	X	
			3	Sensors	X	-	X	-	-	X	-	X	-	X	-	X	
			4	Rails	☆	-	☆	-	-	☆	-	☆	-	☆	-	☆	
			5	Mirror	O	-	O	-	-	O	-	O	-	O	-	O	
			6	Reflector	O	-	O	-	-	O	-	O	-	O	-	O	
			7	Scanner lamp	O	-	O	-	-	O	-	O	-	O	-	O	
			8	Lens	O	-	O	-	-	O	-	O	-	O	-	O	
			9	CCD	O	-	O	-	-	O	-	O	-	O	-	O	
			10	Table glass	O	-	O	-	-	O	-	O	-	O	-	O	
			11	SPF glass	O	-	O	-	-	O	-	O	-	O	-	O	
3	Developing section	Developing unit (monochrome)	1	Developer	X	-	▲	-	-	▲	-	▲	-	▲	Replace as needed.		
			2	DV seal	X	-	X	-	-	X	-	X	-	X			
			3	DV side seals F/R	X	-	X	-	-	X	-	X	-	X			
			4	Toner filter	X	-	X	-	-	X	-	X	-	X	-	X	
			5	Bias pin	X	-	X	-	-	X	-	X	-	X	-	X	
			6	Connector	X	-	X	-	-	X	-	X	-	X	-	X	
		Developing unit (color)	1	Developer	X	▲	-	▲	▲	-	▲	▲	▲	-	▲	Replace as needed.	
			2	DV seal	X	X	-	X	X	-	X	X	X	-	X		
			3	DV side seals F/R	X	X	-	X	X	-	X	X	X	-	X		
			4	Toner filter	X	X	-	X	X	-	X	X	X	-	X		
			5	Bias pin	X	X	-	X	X	-	X	X	X	-	X		
			6	Connector	X	X	-	X	X	-	X	X	X	-	X		
4	OPC drum section	OPC drum unit (monochrome)	1	Drum	X	-	▲	-	-	▲	-	▲	-	▲	Integrated as a drum kit		
			2	MC unit	X	-	▲	-	-	▲	-	▲	-	▲			
			3	Cleaning blade	X	-	▲	-	-	▲	-	▲	-	▲			
		Developing unit (color)	4	Toner reception blade	X	-	X	-	-	X	-	X	-	X	Replace as needed.		
			5	Side seals F/R	X	-	X	-	-	X	-	X	-	X			
			6	Charger cleaner	X	-	▲	-	-	▲	-	▲	-	▲	▲	Integrated as a drum kit	

Section/ Unit work sequence	Section name	Unit name	Parts work sequence	Part name	When calling	60 K	100 K	120 K	180 K	200 K	240 K	300 K	360 K	400 K	Remark	
4	OPC drum section	OPC drum unit (color)	1	Drum	×	▲	–	▲	▲	–	▲	▲	▲	–	Integrated as a drum kit	
			2	MC unit	×	▲	–	▲	▲	–	▲	▲	▲	–		
			3	Cleaning blade	×	▲	–	▲	▲	–	▲	▲	▲	–		
			4	Toner reception blade	×	×	–	×	×	–	×	×	×	×	–	Replace as needed.
			5	Side seals F/R	×	×	–	×	×	–	×	×	×	×	–	
			6	Charger cleaner	×	▲	–	▲	▲	–	▲	▲	▲	▲	–	Integrated as a drum kit
5	Transfer section	Primary transfer unit	1	Separation pawl	×	–	×	–	–	×	–	×	–	×	Replace as needed.	
			2	Primary transfer belt	×	–	▲	–	–	▲	–	▲	–	▲	When replacing, apply KYNAR powder.	
			3	Secondary drive transmission gear	×	–	○	–	–	○	–	○	–	○		
			4	Primary transfer belt drive roller	×	–	○	–	–	○	–	○	–	○		
			5	Primary transfer belt follower roller	×	–	○	–	–	○	–	○	–	○		
			6	Primary transfer belt tension roller	×	–	○	–	–	○	–	○	–	○		
			7	Registration backup roller	×	–	○	–	–	○	–	○	–	○		
			8	Y auxiliary roller	×	–	○	–	–	○	–	○	–	○		
			9	PTC backup roller	×	–	○	–	–	○	–	○	–	○		
			10	Primary transfer roller	×	–	×	–	–	×	–	×	–	×	Replace as needed.	
			11	Transfer cleaner seals F/R	×	–	×	–	–	×	–	×	–	×		
			12	Primary transfer belt cleaner blade	×	–	▲	–	–	▲	–	▲	–	▲		
			13	Primary transfer toner reception blade	×	–	×	–	–	×	–	×	–	×	Replace as needed.	
			14	Primary transfer operation mode detector	×	–	○	–	–	○	–	○	–	○		
6	Transfer section	Secondary transfer unit	1	Secondary transfer belt follower roller	×	–	–	–	–	–	–	○	–	–		
			2	Secondary transfer belt	×	–	–	–	–	–	–	–	▲	–	–	Never use alcohol or solvents for cleaning. Replace at every 300K.
			3	Secondary transfer belt drive roller	×	–	–	–	–	–	–	–	○	–	–	
			4	Secondary transfer backup roller	×	–	–	–	–	–	–	–	○	–	–	
			5	Secondary transfer belt tension roller	×	–	–	–	–	–	–	–	○	–	–	
			6	Secondary transfer roller	×	–	–	–	–	–	–	–	×	–	–	Replace as needed.
			7	Secondary transfer drive gear	×	–	–	–	–	–	–	–	×	–	–	

Section/ Unit work sequence	Section name	Unit name	Parts work sequence	Part name	When calling	60 K	100 K	120 K	180 K	200 K	240 K	300 K	360 K	400 K	Remark
6	Transfer section	Secondary transfer unit	8	Separation cam	×	-	-	-	-	-	-	☆	-	-	When replacing, apply HANARL FL-955R to the shaft section.
			9	Secondary transfer frame	×	-	-	-	-	-	-	-	☆	-	
7		Other	1	PTC unit	×	○	▲	○	○	▲	○	▲	○	▲	
			2	Image density sensor/ Registration sensor/ Standard reflection plate	×	-	○	-	-	○	-	○	-	-	○
8	LSU section	LSU	1	Dust-proof glass	○	-	○	-	-	○	-	○	-	○	Use the LSU cleaning rod.
		Other	2	Cleaning base	×	Replace every time the waste toner box is replaced.									Attached to the waste toner box. (2 pcs.) / Replace when the waste toner box is replaced, or at 100K, or 2 years of use.
9	Manual paper feed section	Manual paper feed unit	1	Paper feed roller	×	-	○	-	-	○	-	○	-	○	Replace at 100K of the manual paper feed counter or 1 year of use.
			2	Separation roller	×	-	○	-	-	○	-	○	-	○	
			3	Torque limiter	×	-	×	-	-	×	-	×	-	×	
			4	Transport roller 9	×	-	○	-	-	○	-	○	-	○	
			5	Sensors	×	-	×	-	-	×	-	×	-	×	
			-	Paper guides	○	-	○	-	-	○	-	○	-	○	Clean with alcohol.
10	Tray paper feed section	Tray paper feed unit	1	Paper pickup roller	×	-	○	-	-	○	-	○	-	○	Replace at 100K of the tray paper feed counter or 1 year of use.
			2	Paper feed roller	×	-	○	-	-	○	-	○	-	○	
			3	Separation roller	×	-	○	-	-	○	-	○	-	○	
			4	Transport roller 4	×	-	○	-	-	○	-	○	-	○	
			5	Transport roller 2	×	-	○	-	-	○	-	○	-	○	
			6	Torque limiter	×	-	×	-	-	×	-	×	-	×	
			7	Sensors	×	-	×	-	-	×	-	×	-	×	
						-	Paper guides	○	-	○	-	-	○	-	○
11	Paper registration section (paper transport section)/ Paper exit section/ ADU section	PS unit	1	Registration roller (idle)	×	-	○	-	-	○	-	○	-	○	
			2	Registration roller (drive)	×	-	○	-	-	○	-	○	-	○	
			3	Transport roller 5	×	-	○	-	-	○	-	○	-	○	
			4	Sensors	×	-	×	-	-	×	-	×	-	×	
		Right door unit	5	Transport roller 7	×	-	○	-	-	○	-	○	-	○	
			6	Transport roller 8	×	-	○	-	-	○	-	○	-	○	
			7	Paper exit roller 2	×	-	○	-	-	○	-	○	-	○	
			8	Discharge brush	×	-	×	-	-	×	-	×	-	×	
			9	Sensors	×	-	×	-	-	×	-	×	-	×	
		Fusing rear unit	10	Transport roller 6	×	-	○	-	-	○	-	○	-	○	
		Paper exit unit	11	Paper exit roller 1	×	-	○	-	-	○	-	○	-	○	
			12	Discharge brush	×	-	×	-	-	×	-	×	-	×	
			13	Sensors	×	-	×	-	-	×	-	×	-	×	
		Other	14	Paper dust removing unit	○	-	▲	-	-	▲	-	▲	-	▲	
			-	Paper guides	○	-	○	-	-	○	-	○	-	○	Clean with alcohol.

Section/ Unit work sequence	Section name	Unit name	Parts work sequence	Part name	When calling	60 K	100 K	120 K	180 K	200 K	240 K	300 K	360 K	400 K	Remark	
12	Drive section	Main drive unit	1	Gears (grease)	×	-	×	-	-	×	-	×	-	×	Apply to the specified position when checking. FLOIL G-313S	
			2	Shafts (grease)	×	-	×	-	-	×	-	×	-	×		
			3	Shaft earth sections (conduction grease)	×	-	×	-	-	×	-	×	-	×	×	Apply to the specified position when checking. FLOIL GE-676
			4	Belts	×	-	×	-	-	×	-	×	-	×	×	
			5	Sensors	×	-	×	-	-	×	-	×	-	×	×	
		Transport drive unit	6	Belts	×	-	×	-	-	×	-	×	-	×	×	
			7	Connection arm	×	-	×	-	-	×	-	×	-	×	×	Apply to the specified position when checking. HANARL FL-955R
		Fusing drive unit	8	Shafts (grease)	×	-	×	-	-	×	-	×	-	×	×	
			Paper exit drive unit	9	Shafts (grease)	×	-	×	-	-	×	-	×	-	×	
		10		Belts	×	-	×	-	-	×	-	×	-	×	×	
13	Fusing section	Fusing unit	1	Lower separation pawl	×	-	×	-	-	×	-	×	-	×		
			2	Lower separation pawl spring	×	-	×	-	-	×	-	×	-	×	×	
			3	Separation plate	×	-	×	-	-	×	-	×	-	×	×	
			4	Oil applying roller	×	-	▲	-	-	▲	-	▲	-	▲	▲	
			5	Backup roller	×	-	▲	-	-	▲	-	▲	-	▲	▲	
			6	CL roller bearing	×	-	▲	-	-	▲	-	▲	-	▲	▲	
			7	Lower thermistor	×	-	×	-	-	×	-	×	-	×	×	Replace as needed.
			8	Pressure roller gear	×	-	×	-	-	×	-	×	-	×	×	
			9	Pressure roller bearing	×	-	×	-	-	×	-	×	-	×	×	
			10	Pressure roller	×	-	×	-	-	▲	-	×	-	▲	▲	Apply grease to the shaft section when replacing. (JEF552) / After completion of replacement, clean the new pressure roller surface with alcohol. / Integrated with the fusing roller as a maintenance kit.
			11	Sub thermistor	×	-	×	-	-	×	-	×	-	×	×	Replace as needed.
			12	Fusing roller bearing	×	-	×	-	-	×	-	×	-	×	×	
			13	Heat- insulating bush	×	-	×	-	-	×	-	×	-	×	×	Replace as needed. / When replacing, apply grease to the inner ring section and the outer ring section. (JEF552)
			14	Heating roller bearing	×	-	×	-	-	×	-	×	-	×	×	Replace as needed.
			15	Fuser belt guide collar	×	-	▲	-	-	▲	-	▲	-	▲	▲	Integrated with the fuser belt as a maintenance kit.
			16	Fusing roller	×	-	×	-	-	▲	-	×	-	▲	▲	Apply grease to the shaft section when replacing. (JEF552) / Integrated with the pressure roller as a maintenance kit.
			17	Heating roller	×	-	×	-	-	×	-	×	-	×	×	Replace as needed.
			18	Fusing belt (Except North America)	×	-	▲	-	-	▲	-	▲	-	▲	▲	Integrated with the fuser belt guide collar as a maintenance kit. / When replacing, clean the fusing belt surface with alcohol.
				Fusing belt (North America)	×	-	-	-	-	▲	-	-	-	-	▲	
19	Main thermistor	×	-	×	-	-	×	-	×	-	×	×	Replace as needed.			

Section/ Unit work sequence	Section name	Unit name	Parts work sequence	Part name	When calling	60 K	100 K	120 K	180 K	200 K	240 K	300 K	360 K	400 K	Remark
13	Fusing section	Fusing unit	20	Paper guides	○	–	○	–	–	○	–	○	–	○	
			21	Gears	×	–	×	–	–	×	–	×	–	×	Replace as needed.
			22	Lower scraper assembly	×	–	▲	–	–	▲	–	▲	–	▲	
			23	Pressure spring	×	–	×	–	–	×	–	×	–	×	
			24	Washer	×	–	×	–	–	×	–	×	–	×	
14	Other		1	Ozone filter	–	–	▲	–	–	▲	–	▲	–	▲	
			2	Toner cartridge BK	User replacement for every toner empty.										
			3	Toner cartridge C											
			4	Toner cartridge M											
			5	Toner cartridge Y											
			6	Waste toner box	Replaced by the user when full is detected.										

\* 1: Note for cleaning the image density sensor, the registration sensor, and the standard reflection plate

When in maintenance or in case of a service call, refer to "Criteria for necessity of cleaning" below to judge the necessity of cleaning the image density sensor, the registration sensor, and the standard reflection plate. If it is judged that cleaning is necessary, then execute cleaning.

#### Criteria for necessity of cleaning

- The SIM44-2 PCS\_CL LED ADJ value is increased by aging and dirt of the image density sensor and the standard reflection plate.
- When the density of an output image is decreased and the difference between the SIM44-2 PCS\_CL LED ADJ value and the SIM44-13 PCS\_CL LED ADJ value is 30 or more, the image density sensor, the registration sensor, and the standard reflection plate may be dirtied.

In this case, clean the image density sensor, the registration sensor, and the standard reflection plate with dry cloth, and perform calibration with SIM44-13 by using the calibration tool (UKOG-0318FCZZ).

After completion of cleaning, use SIM46-74 ADJ 10B to adjust the copy/printer color balance.

#### Note

#### Greasing

Greasing is not always required for every maintenance. In the following cases, check and grease.

- When there are some noises.
- When a lot of jams occur frequently. (Check the jam history.)

For the part code of grease to be used, refer to "[15] TOOL LIST."

#### Note

#### Cleaning of sensors and detectors in the paper feed/transport system

Cleaning of sensors and detectors in the paper feed/transport system is not always required for every maintenance. In the following cases, check and clean.

- When a trouble or a jam occurs due to a sensor or a detector. (Check the jam history.)

#### Note

#### Torque limiter check and replacement

Torque limiter check and replacement is not always required for every maintenance. In the following cases, check and replace.

- When there are some noises.
- When a lot of jams occur frequently. (Check the jam history.)

#### Note

#### Alcohol for cleaning

Be sure to use ethanol for cleaning.

#### Note

#### Cleaning of the primary transfer mode detector (CL/BK)

- When replacing the OPC drum, remove the primary transfer unit and the developing unit, and clean them. (Every 100K)
- Blow air to the light emitting section and light receiving section to remove the attached toner.
- Blow air also when the sensor is wiped and cleaned with waste cloth.

**Main unit (36cpm machine)**

X: Check (Clean, replace, or adjust according to necessity.) O: Clean ▲: Replace △: Adjust ☆: Lubricate

Section/ Unit work sequence	Section name	Unit name	Parts work sequence	Part name	When calling	70 K	120 K	140 K	210 K	240 K	280 K	350 K	360 K	Remark		
1	RSPF section	RSPF unit	1	Document pickup roller	O	-	O	-	-	O	-	-	O	Replace at 100K of the SPF paper feed counter or 1 year of use. When replacing the paper feed roller, apply grease to the paper feed shaft. GP-501MR		
			2	Paper feed roller	O	-	O	-	-	O	-	-	O			
			3	Separation roller	O	-	O	-	-	O	-	-	O			
			4	Torque limiter SPF	X	-	X	-	-	X	-	-	X	-	X	Replace at 400K of the SPF paper feed counter or 2 years of use.
			5	Take-up torque limiter	X	-	X	-	-	X	-	-	X	-	X	
			6	Discharge brush	X	-	X	-	-	X	-	-	X	-	X	
			7	Registration roller	O	-	O	-	-	O	-	-	O	-	O	
			8	Transport roller 2	O	-	O	-	-	O	-	-	O	-	O	
			9	Transport roller 3	O	-	O	-	-	O	-	-	O	-	O	
			10	Paper exit roller	O	-	O	-	-	O	-	-	O	-	O	
			11	Sensors	X	-	X	-	-	X	-	-	X	-	X	
			12	Scan plate	O	-	O	-	-	O	-	-	O	-	O	
			13	Gears	X	-	X	-	-	X	-	-	X	-	X	
			14	Belts	X	-	X	-	-	X	-	-	X	-	X	
			15	OC mat	O	-	O	-	-	O	-	-	O	-	O	
2	Scanner section	Scanner unit	1	Drive belt	X	-	X	-	-	X	-	-	X			
			2	Drive wire	X	-	X	-	-	X	-	-	X	-	X	
			3	Sensors	X	-	X	-	-	X	-	-	X	-	X	
			4	Rails	☆	-	☆	-	-	☆	-	-	☆	-	☆	
			5	Mirror	O	-	O	-	-	O	-	-	O	-	O	
			6	Reflector	O	-	O	-	-	O	-	-	O	-	O	
			7	Scanner lamp	O	-	O	-	-	O	-	-	O	-	O	
			8	Lens	O	-	O	-	-	O	-	-	O	-	O	
			9	CCD	O	-	O	-	-	O	-	-	O	-	O	
			10	Table glass	O	-	O	-	-	O	-	-	O	-	O	
			11	SPF glass	O	-	O	-	-	O	-	-	O	-	O	
3	Developing section	Developing unit (monochrome)	1	Developer	X	-	▲	-	-	▲	-	-	▲			
			2	DV seal	X	-	X	-	-	X	-	-	X	-	X	
			3	DV side seals F/R	X	-	X	-	-	X	-	-	X	-	X	
			4	Toner filter	X	-	X	-	-	X	-	-	X	-	X	
			5	Bias pin	X	-	X	-	-	X	-	-	X	-	X	
			6	Connector	X	-	X	-	-	X	-	-	X	-	X	
		Developing unit (color)	1	Developer	X	▲	-	▲	▲	-	▲	▲	-	-	-	
			2	DV seal	X	X	-	X	X	-	X	X	-	X	-	X
			3	DV side seals F/R	X	X	-	X	X	-	X	X	-	X	-	X
			4	Toner filter	X	X	-	X	X	-	X	X	-	X	-	X
			5	Bias pin	X	X	-	X	X	-	X	X	-	X	-	X
			6	Connector	X	X	-	X	X	-	X	X	-	X	-	X
4	OPC drum section	OPC drum unit (monochrome)	1	Drum	X	-	▲	-	-	▲	-	-	▲	Integrated as a drum kit		
			2	MC unit	X	-	▲	-	-	▲	-	-	▲			
			3	Cleaning blade	X	-	▲	-	-	▲	-	-	▲			
		4	Toner reception blade	X	-	X	-	-	X	-	-	X	-	X	Replace as needed.	
		5	Side seals F/R	X	-	X	-	-	X	-	-	X	-	X		
		6	Charger cleaner	X	-	▲	-	-	▲	-	-	▲	-	▲		

Section/ Unit work sequence	Section name	Unit name	Parts work sequence	Part name	When calling	70 K	120 K	140 K	210 K	240 K	280 K	350 K	360 K	Remark	
4	OPC drum section	OPC drum unit (color)	1	Drum	×	▲	–	▲	▲	–	▲	▲	▲	Integrated as a drum kit	
			2	MC unit	×	▲	–	▲	▲	–	▲	▲	▲		
			3	Cleaning blade	×	▲	–	▲	▲	–	▲	▲	▲		
			4	Toner reception blade	×	×	–	×	×	–	×	×	×	×	Replace as needed.
			5	Side seals F/R	×	×	–	×	×	–	×	×	×	×	Integrated as a drum kit
			6	Charger cleaner	×	▲	–	▲	▲	–	▲	▲	▲	▲	
5	Transfer section	Primary transfer unit	1	Separation pawl	×	–	×	–	–	×	–	×	–	Replace as needed.	
			2	Primary transfer belt	×	–	▲	–	–	▲	–	–	▲	When replacing, apply KYNAR powder.	
			3	Secondary drive transmission gear	×	–	○	–	–	○	–	–	○		
			4	Primary transfer belt drive roller	×	–	○	–	–	○	–	–	○		
			5	Primary transfer belt follower roller	×	–	○	–	–	○	–	–	○		
			6	Primary transfer belt tension roller	×	–	○	–	–	○	–	–	○		
			7	Registration backup roller	×	–	○	–	–	○	–	–	○		
			8	Y auxiliary roller	×	–	○	–	–	○	–	–	○		
			9	PTC backup roller	×	–	○	–	–	○	–	–	○		
			10	Primary transfer roller	×	–	×	–	–	×	–	–	×	Replace as needed.	
			11	Transfer cleaner seals F/R	×	–	×	–	–	×	–	–	×		
			12	Primary transfer belt cleaner blade	×	–	▲	–	–	▲	–	–	▲		
			13	Primary transfer toner reception blade	×	–	×	–	–	×	–	–	×	Replace as needed.	
			14	Primary transfer operation mode detector	×	–	○	–	–	○	–	–	○		
6	Transfer section	Secondary transfer unit	1	Secondary transfer belt follower roller	×	–	–	–	–	–	–	–	○		
			2	Secondary transfer belt	×	–	–	–	–	–	–	–	▲	Never use alcohol or solvents for cleaning. Replace at every 360K.	
			3	Secondary transfer belt drive roller	×	–	–	–	–	–	–	–	○		
			4	Secondary transfer backup roller	×	–	–	–	–	–	–	–	○		
			5	Secondary transfer belt tension roller	×	–	–	–	–	–	–	–	○		
			6	Secondary transfer roller	×	–	–	–	–	–	–	–	×	Replace as needed.	
			7	Secondary transfer drive gear	×	–	–	–	–	–	–	–	×		



Section/ Unit work sequence	Section name	Unit name	Parts work sequence	Part name	When calling	70 K	120 K	140 K	210 K	240 K	280 K	350 K	360 K	Remark	
6	Transfer section	Secondary transfer unit	8	Separation cam	×	-	-	-	-	-	-	-	☆	When replacing, apply HANARL FL-955R to the shaft section.	
			9	Secondary transfer frame	×	-	-	-	-	-	-	-	-		☆
7		Other	1	PTC unit	×	○	▲	○	○	▲	○	○	▲	Replace. Reciprocate the PTC cleaning rod back and forth 3 times.	
			2	Image density sensor/ Registration sensor/ Standard reflection plate	×	-	○	-	-	○	-	-	-	○	Remove dirt from the light emitting/receiving sections (transparent plastic sections) of the sensor and the standard reflection plate (gray plastic section) with dry waste cloth. *1
8	LSU section	LSU	1	Dust-proof glass	○	-	○	-	-	○	-	-	○	Use the LSU cleaning rod.	
		Other	2	Cleaning base	×	Replace every time the waste toner box is replaced.							Attached to the waste toner box. (2 pcs.) / Replace when the waste toner box is replaced, or at 100K, or 2 years of use.		
9	Manual paper feed section	Manual paper feed unit	1	Paper feed roller	×	-	○	-	-	○	-	-	○	Replace at 100K of the manual paper feed counter or 1 year of use.	
			2	Separation roller	×	-	○	-	-	○	-	-	○		
			3	Torque limiter	×	-	×	-	-	×	-	-	-	×	
			4	Transport roller 9	×	-	○	-	-	○	-	-	-	○	
			5	Transport roller 10	×	-	○	-	-	○	-	-	-	○	
			6	Sensors	×	-	×	-	-	×	-	-	-	×	
			-	Paper guides	○	-	○	-	-	○	-	-	-	○	Clean with alcohol.
10	Tray paper feed section	Tray paper feed unit	1	Paper pickup roller	×	-	○	-	-	○	-	-	○	Replace at 100K of the tray paper feed counter or 1 year of use.	
			2	Paper feed roller	×	-	○	-	-	○	-	-	○		
			3	Separation roller	×	-	○	-	-	○	-	-	-	○	
			4	Transport roller 4	×	-	○	-	-	○	-	-	-	○	
			5	Transport roller 2	×	-	○	-	-	○	-	-	-	○	
			6	Torque limiter	×	-	×	-	-	×	-	-	-	×	
			7	Sensors	×	-	×	-	-	×	-	-	-	×	
-	Paper guides	○	-	○	-	-	○	-	-	-	○	Clean with alcohol.			
11	Paper registration section (paper transport section)/ Paper exit section/ ADU section	PS unit	1	Registration roller (idle)	×	-	○	-	-	○	-	-	○		
			2	Registration roller (drive)	×	-	○	-	-	○	-	-	○		
			3	Transport roller 5	×	-	○	-	-	○	-	-	○		
			4	Sensors	×	-	×	-	-	×	-	-	-	×	
		Right door unit	5	Transport roller 7	×	-	○	-	-	○	-	-	-	○	
			6	Transport roller 8	×	-	○	-	-	○	-	-	-	○	
			7	Paper exit roller 3	×	-	○	-	-	○	-	-	-	○	
			8	Paper exit roller 2	×	-	○	-	-	○	-	-	-	○	
			9	Discharge brush	×	-	×	-	-	×	-	-	-	×	
			10	Sensors	×	-	×	-	-	×	-	-	-	×	

Section/ Unit work sequence	Section name	Unit name	Parts work sequence	Part name	When calling	70 K	120 K	140 K	210 K	240 K	280 K	350 K	360 K	Remark	
11	Paper registration section (paper transport section)/ Paper exit section/ ADU section	Fusing rear unit	11	Transport roller 6	×	-	○	-	-	○	-	-	○		
		Paper exit unit	12	Paper exit roller 1	×	-	○	-	-	○	-	-	-	○	
			13	Discharge brush	×	-	×	-	-	×	-	-	-	×	
			14	Sensors	×	-	×	-	-	×	-	-	-	×	
		Other	15	Paper dust removing unit	○	-	▲	-	-	▲	-	-	-	▲	
-	-	Paper guides	○	-	○	-	-	○	-	-	-	○	Clean with alcohol.		
12	Drive section	Main drive unit Belt drive unit	1	Gears (grease)	×	-	×	-	-	×	-	-	×	Apply to the specified position when checking. FLOIL G-313S	
			2	Shafts (grease)	×	-	×	-	-	×	-	-	×		
			3	Shaft earth sections (conduction grease)	×	-	×	-	-	×	-	-	-	×	Apply to the specified position when checking. FLOIL GE-676
			4	Belts	×	-	×	-	-	×	-	-	-	×	
			5	Sensors	×	-	×	-	-	×	-	-	-	×	
		Transport drive unit	6	Belts	×	-	×	-	-	×	-	-	-	×	
			7	Connection arm	×	-	×	-	-	×	-	-	-	×	Apply to the specified position when checking. HANARL FL-955R
		Fusing drive unit	8	Shafts (grease)	×	-	×	-	-	×	-	-	-	×	
		Paper exit drive unit	9	Shafts (grease)	×	-	×	-	-	×	-	-	-	×	
			10	Belts	×	-	×	-	-	×	-	-	-	×	
11	Lower separation pawl		×	-	×	-	-	×	-	-	-	×			
13	Fusing section	Fusing unit	2	Lower separation pawl spring	×	-	×	-	-	×	-	-	×		
			3	Separation plate	×	-	×	-	-	×	-	-	-	×	
			4	Web guide shaft	×	-	▲	-	-	▲	-	-	-	▲	
			5	Web pressure roller bearing	×	-	▲	-	-	▲	-	-	-	▲	
			6	Web pressure roller	×	-	▲	-	-	▲	-	-	-	▲	
			7	Web roller	×	-	▲	-	-	▲	-	-	-	▲	
			8	Lower thermistor	×	-	×	-	-	×	-	-	-	×	Replace as needed.
			9	Pressure roller gear	×	-	×	-	-	×	-	-	-	×	
			10	Pressure roller bearing	×	-	×	-	-	×	-	-	-	×	
			11	Pressure roller	×	-	×	-	-	▲	-	-	-	×	Apply grease to the shaft section when replacing. (JEF552) / After completion of replacement, clean the new pressure roller surface with alcohol. / Integrated with the fusing roller as a maintenance kit. Replace at every 240K.
			12	Sub thermistor	×	-	×	-	-	×	-	-	-	×	Replace as needed.
			13	Fusing roller bearing	×	-	×	-	-	×	-	-	-	×	
			14	Heat-insulating bush	×	-	×	-	-	×	-	-	-	×	Replace as needed. / When replacing, apply grease to the inner ring section and the outer ring section. (JEF552)
			15	Heating roller bearing	×	-	×	-	-	×	-	-	-	×	Replace as needed.
			16	Fuser belt guide collar	×	-	×	-	-	▲	-	-	-	×	Integrated with the fusing belt as a maintenance kit. Replace at every 240K.

Section/ Unit work sequence	Section name	Unit name	Parts work sequence	Part name	When calling	70 K	120 K	140 K	210 K	240 K	280 K	350 K	360 K	Remark
13	Fusing section	Fusing unit	17	Fusing roller	×	–	×	–	–	▲	–	–	×	Apply grease to the shaft section when replacing. (JEF552) / Integrated with the pressure roller as a maintenance kit. Replace at every 240K.
			18	Heating roller	×	–	×	–	–	×	–	–	×	Replace as needed.
			19	Fusing belt	×	–	×	–	–	▲	–	–	×	Integrated with the fuser belt guide collar as a maintenance kit. / When replacing, clean the fusing belt surface with alcohol. Replace at every 240K.
			20	Main thermistor	×	–	×	–	–	×	–	–	×	Replace as needed.
			21	Paper guides	○	–	○	–	–	○	–	–	○	
			22	Gears	×	–	×	–	–	×	–	–	×	Replace as needed.
			23	Pressure spring	×	–	×	–	–	×	–	–	×	
			24	Washer	×	–	×	–	–	×	–	–	×	
14	Other		1	Ozone filter	–	–	▲	–	–	▲	–	–	▲	
			2	Toner cartridge BK	User replacement for every toner empty.									
			3	Toner cartridge C										
			4	Toner cartridge M										
			5	Toner cartridge Y										
			6	Waste toner box	Replaced by the user when full is detected.									

\* 1: Note for cleaning the image density sensor, the registration sensor, and the standard reflection plate

When in maintenance or in case of a service call, refer to "Criteria for necessity of cleaning" below to judge the necessity of cleaning the image density sensor, the registration sensor, and the standard reflection plate. If it is judged that cleaning is necessary, then execute cleaning.

#### Criteria for necessity of cleaning

- The SIM44-2 PCS\_CL LED ADJ value is increased by aging and dirt of the image density sensor and the standard reflection plate.
- When the density of an output image is decreased and the difference between the SIM44-2 PCS\_CL LED ADJ value and the SIM44-13 PCS\_CL LED ADJ value is 30 or more, the image density sensor, the registration sensor, and the standard reflection plate may be dirtied.  
In this case, clean the image density sensor, the registration sensor, and the standard reflection plate with dry cloth, and perform calibration with SIM44-13 by using the calibration tool (UKOG-0318FCZZ).  
After completion of cleaning, use SIM46-74 ADJ 10B to adjust the copy/printer color balance.

#### Note

##### Greasing

Greasing is not always required for every maintenance. In the following cases, check and grease.

- When there are some noises.
- When a lot of jams occur frequently. (Check the jam history.)  
For the part code of grease to be used, refer to "[15] TOOL LIST."

#### Note

##### Cleaning of sensors and detectors in the paper feed/transport system

Cleaning of sensors and detectors in the paper feed/transport system is not always required for every maintenance. In the following cases, check and clean.

- When a trouble or a jam occurs due to a sensor or a detector. (Check the jam history.)

#### Note

##### Torque limiter check and replacement

Torque limiter check and replacement is not always required for every maintenance. In the following cases, check and replace.

- When there are some noises.
- When a lot of jams occur frequently. (Check the jam history.)

#### Note

##### Alcohol for cleaning

Be sure to use ethanol for cleaning.

#### Note

##### Cleaning of the primary transfer mode detector (CL/BK)

- When replacing the OPC drum, remove the primary transfer unit and the developing unit, and clean them.
- Blow air to the light emitting section and light receiving section to remove the attached toner.
- Blow air also when the sensor is wiped and cleaned with waste cloth.

**Option**

×: Check (Clean, replace, or adjust according to necessity.) ○: Clean ▲: Replace △: Adjust ☆: Lubricate

Option name	Unit work sequence	Unit name	Parts work sequence	Part name	When calling	At the machine cycle	Remark
Stand/ 500 sheet paper drawer	1	Tray 2 paper feed unit	1	Paper pickup roller	×	○	Replace at 100K of each tray paper feed counter or 1 year of use.
			2	Paper feed roller	×	○	
			3	Separation roller	×	○	
			4	Transport roller 1	×	○	
			5	Torque limiter	×	×	Replace at 100K of each tray paper feed counter.
			6	Sensors	×	×	
	–	Paper guides	○	○	Clean with alcohol.		
	2	1CS drive unit	7	Gears (grease)	×	×	Apply to the specified position when checking. HANARL FL-955R
8			Shafts (grease)	×	×	Apply to the specified position when checking. FLOIL G-313S	
Stand/ 2x500 sheet paper drawer	1	Tray 2 paper feed unit	1	Paper pickup roller	×	○	Replace at 100K of each tray paper feed counter or 1 year of use.
			2	Paper feed roller	×	○	
			3	Separation roller	×	○	
			4	Transport roller 1	×	○	
			5	Torque limiter	×	×	Replace at 100K of each tray paper feed counter.
			6	Sensors	×	×	
	–	Paper guides	○	○	Clean with alcohol.		
	2	Tray 3 paper feed unit	7	Paper pickup roller	×	○	Replace at 100K of each tray paper feed counter or 1 year of use.
			8	Paper feed roller	×	○	
			9	Separation roller	×	○	
			10	Vertical transport roller 1	×	○	
			11	Transport roller 3	×	○	
			12	Torque limiter	×	×	Replace at 100K of each tray paper feed counter.
	13	Sensors	×	×			
	–	Paper guides	○	○	Clean with alcohol.		
	3	1CS drive unit	14	Gears (grease)	×	×	Apply to the specified position when checking. HANARL FL-955R
			15	Shafts (grease)	×	×	Apply to the specified position when checking. FLOIL G-313S
	4	2CS drive unit	16	Gears (grease)	×	×	Apply to the specified position when checking. HANARL FL-955R
17			Shafts (grease)	×	×	Apply to the specified position when checking. FLOIL G-313S	

Option name	Unit work sequence	Unit name	Parts work sequence	Part name	When calling	At the machine cycle	Remark
Stand/ 3x500 sheet paper drawer	1	Tray 2 paper feed unit	1	Paper pickup roller	×	○	Replace at 100K of each tray paper feed counter or 1 year of use.
			2	Paper feed roller	×	○	
			3	Separation roller	×	○	
			4	Transport roller 1	×	○	
			5	Torque limiter	×	×	Replace at 100K of each tray paper feed counter.
			6	Sensors	×	×	
		–	Paper guides	○	○	Clean with alcohol.	
	2	Tray 3 paper feed unit	7	Paper pickup roller	×	○	Replace at 100K of each tray paper feed counter or 1 year of use.
			8	Paper feed roller	×	○	
			9	Separation roller	×	○	
			10	Vertical transport roller 1	×	○	
			11	Transport roller 3	×	○	
			12	Torque limiter	×	×	Replace at 100K of each tray paper feed counter.
		13	Sensors	×	×		
		–	Paper guides	○	○	Clean with alcohol.	
	3	Tray 4 paper feed unit	14	Paper pickup roller	×	○	Replace at 100K of each tray paper feed counter or 1 year of use.
			15	Paper feed roller	×	○	
			16	Separation roller	×	○	
			17	Vertical transport roller 2	×	○	
			18	Transport roller 5	×	○	
19			Torque limiter	×	×	Replace at 100K of each tray paper feed counter.	
	20	Sensors	×	×			
	–	Paper guides	○	○	Clean with alcohol.		
4	1CS drive unit	21	Gears (grease)	×	×	Apply to the specified position when checking. HANARL FL-955R	
		22	Shafts (grease)	×	×	Apply to the specified position when checking. FLOIL G-313S	
5	2CS drive unit	23	Gears (grease)	×	×	Apply to the specified position when checking. HANARL FL-955R	
		24	Shafts (grease)	×	×	Apply to the specified position when checking. FLOIL G-313S	
6	3CS drive unit	25	Shafts (grease)	×	×	Apply to the specified position when checking. FLOIL G-313S	
Large capacity tray	1	Paper feed unit	1	Paper pickup roller	×	○	As a rough guide, these rollers should be replaced when each tray paper feed counter reaches a value of 100K or when one year has elapsed since the start of use.
			2	Paper feed roller	×	○	
			3	Separation roller	×	○	
			4	Torque limiter	×	×	As a rough guide, the torque limiter should be replaced when each tray paper feed counter reaches a value of 800K.
			5	Transport roller	×	○	
			6	Each gear (grease)	×	×	When checking, apply to the specified positions. HANARL FL-955R
			7	Each sensor	×	×	
		–	Each paper guide	○	○	Clean with alcohol.	
	2	Drive unit	8	Each gear (grease)	×	×	When checking, apply to the specified positions. MOLYKOTE X5-6020 MOLYKOTE BR-2 Plus
			9	Each belt	×	×	
			10	Each sensor	×	×	
	3	Other	11	Each gear (grease)	×	×	When checking, apply to the specified positions. MOLYKOTE X5-6020
12			Each sensor	×	×		

Option name	Parts work sequence	Part name	When calling	At the machine cycle	Remark
Finisher	1	Staple cartridge	×	×	Replacement is made by the user at every 5,000 pcs.
	2	Staple unit	×	×	Replacement reference: Replace the unit at every 200K staple.
	3	Paddle	×	○	
	4	Inlet port paper transport roller	×	○	
	5	Inlet port paper transport roller B	×	○	
	6	Discharge brush	×	×	
	7	Paper exit roller B	×	○	
	8	Paper exit roller	×	○	
	9	Bundle exit paper transport roller	×	○	
	10	Bundle exit paper exit transport roller B	×	○	
	11	Scraping roller	×	○	Replacement reference: Replace at every 1000K of the finisher paper exit count value.
	12	Sensors	×	×	
	-	Paper guides	×	○	Clean with alcohol.
Punch unit	1	Punch unit	×	×	Replacement reference: Replace the unit at every 1000K.
	2	Sensors	×	×	
Paper pass unit	1	Inlet port roller	○	○	
	2	Inlet port rear roller	○	○	
	3	Paper exit front roller	○	○	
	4	Paper exit roller	○	○	
	5	Sensors	×	×	
	-	Paper guides	×	○	Clean with alcohol.
Saddle stitch finisher	1	Transport rollers	○	○	
	2	Knurling belt	×	○	
	3	Discharge brush	×	×	
	4	Sensors	×	×	
	5	Staple unit	×	×	Replacement reference: Replace the unit at every 200K staple.
	6	Staple unit (for saddle)	×	×	Replacement reference: Replace the unit at every 100K staple.
	7	Staple unit	×	×	Replacement reference: Replacement is made by the user at every 5,000 pcs.
	8	Staple unit (for saddle)	×	×	Replacement reference: Replacement is made by the user at every 2,000 pcs.
	-	Gears	×	×	
	-	Belts	×	×	
Punch unit	-	Paper guides	×	○	Clean with alcohol.
	1	Punch unit	×	×	Replacement reference: Replace the unit at every 1000K.
	2	Sensors	×	×	

### Note

#### Greasing

Greasing is not always required for every maintenance. In the following cases, check and grease.

- When there are some noises.
- When a lot of jams occur frequently. (Check the jam history.)

For the part code of grease to be used, refer to "[15] TOOL LIST."

### Note

#### Cleaning of sensors and detectors in the paper feed/transport system

Cleaning of sensors and detectors in the paper feed/transport system is not always required for every maintenance. In the following cases, check and clean.

- When a trouble or a jam occurs due to a sensor or a detector. (Check the jam history.)

### Note

#### Torque limiter check and replacement

Torque limiter check and replacement is not always required for every maintenance. In the following cases, check and replace.







- When there are some noises.
- When a lot of jams occur frequently. (Check the jam history.)





### Note

#### Alcohol for cleaning

Be sure to use ethanol for cleaning.

## A. RSPF section

✕/  : Check (Clean, replace, or adjust according to necessity.)    ○/       : Clean

▲/  : Replace    △/  : Adjust    ☆/    : Lubricate

### 18cpm machine

Unit name	Parts work sequence	Part name	When calling	80k	160k	240k	320k	400k	480k	Remark	
RSPF unit	1	Document pickup roller	○	○	○	○	○	○	○	Replace at 80K of the SPF paper feed counter or 1 year of use. When replacing the paper feed roller, apply grease to the paper feed shaft. GP-501MR (UKOG-0013QSZZ)	
	2	Paper feed roller	○	○	○	○	○	○	○		
	3	Separation roller	○	○	○	○	○	○	○		
	4	Torque limiter SPF	✕	✕	✕	✕	✕	✕	✕	Replacement reference: Replace referring to the paper feed counter value. SPF section torque limiter: Replace at 400K or 2 years of use.	
	5	Take-up torque limiter	✕	✕	✕	✕	✕	✕	✕		
	6	Discharge brush	✕	✕	✕	✕	✕	✕	✕	✕	
	7	Registration roller	○	○	○	○	○	○	○	○	
	8	Transport roller 2	○	○	○	○	○	○	○	○	
	9	Transport roller 3	○	○	○	○	○	○	○	○	
	10	Paper exit roller	○	○	○	○	○	○	○	○	
	11	Sensors	✕	✕	✕	✕	✕	✕	✕	✕	
	12	Scan plate	○	○	○	○	○	○	○	○	
	13	Gears	✕	✕	✕	✕	✕	✕	✕	✕	
	14	Belts	✕	✕	✕	✕	✕	✕	✕	✕	
	15	OC mat	○	○	○	○	○	○	○	○	

### 20cpm/23cpm/26cpm/31cpm machine

Unit name	Parts work sequence	Part name	When calling	60 K	100 K	120 K	180 K	200 K	240 K	300 K	360 K	400 K	Remark
RSPF unit	1	Document pickup roller	○	-	○	-	-	○	-	○	-	○	Replace at 100K of the SPF paper feed counter or 1 year of use. When replacing the paper feed roller, apply grease to the paper feed shaft. GP-501MR
	2	Paper feed roller	○	-	○	-	-	○	-	○	-	○	
	3	Separation roller	○	-	○	-	-	○	-	○	-	○	
	4	Torque limiter SPF	✕	-	✕	-	-	✕	-	✕	-	✕	Replace at 400K of the SPF paper feed counter or 2 years of use.
	5	Take-up torque limiter	✕	-	✕	-	-	✕	-	✕	-	✕	
	6	Discharge brush	✕	-	✕	-	-	✕	-	✕	-	✕	
	7	Registration roller	○	-	○	-	-	○	-	○	-	○	
	8	Transport roller 2	○	-	○	-	-	○	-	○	-	○	
	9	Transport roller 3	○	-	○	-	-	○	-	○	-	○	
	10	Paper exit roller	○	-	○	-	-	○	-	○	-	○	
	11	Sensors	✕	-	✕	-	-	✕	-	✕	-	✕	
	12	Scan plate	○	-	○	-	-	○	-	○	-	○	
	13	Gears	✕	-	✕	-	-	✕	-	✕	-	✕	
	14	Belts	✕	-	✕	-	-	✕	-	✕	-	✕	
	15	OC mat	○	-	○	-	-	○	-	○	-	○	

36cpm machine

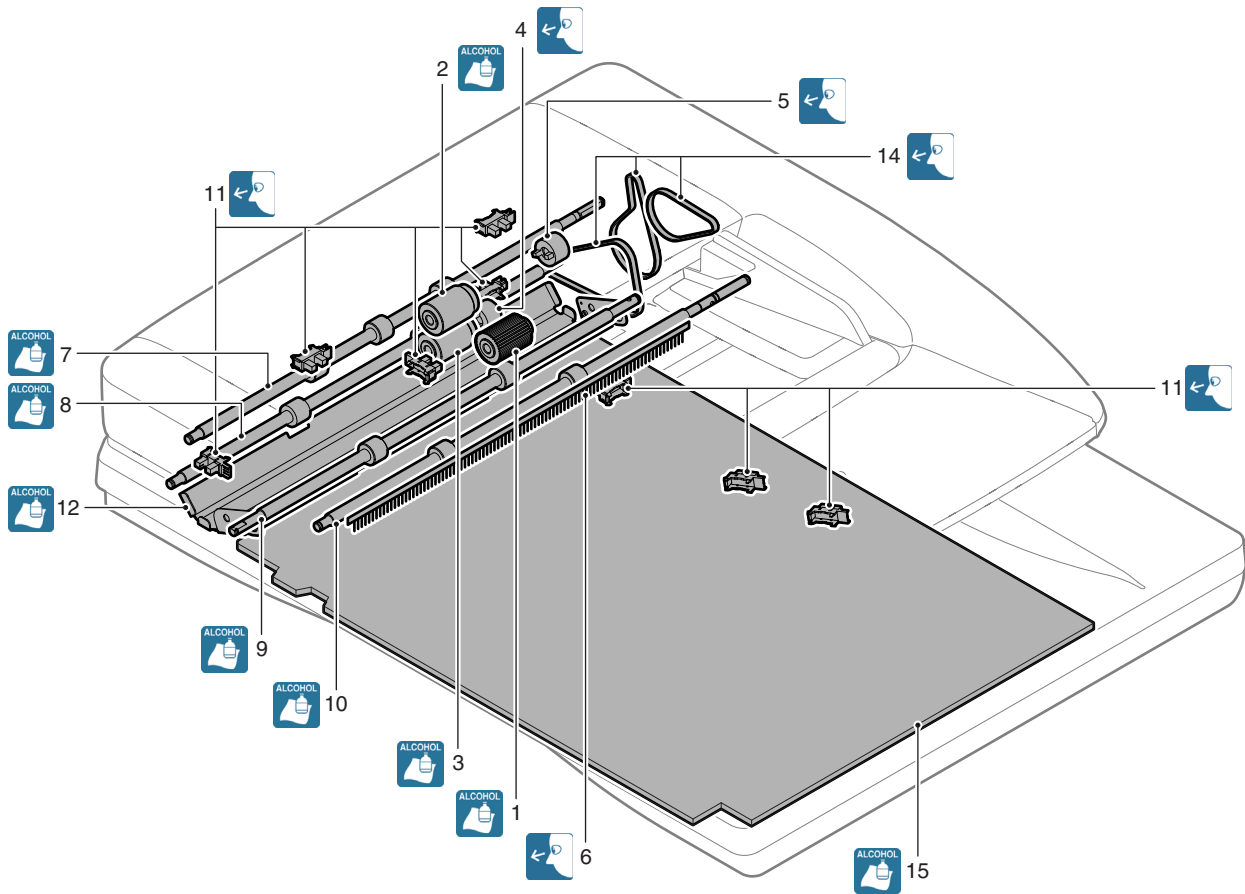

Unit name	Parts work sequence	Part name	When calling	70K	120K	140K	210K	240K	280K	350K	360K	Remark
RSPF unit	1	Document pickup roller	○	-	○	-	-	○	-	-	○	Replace at 100K of the SPF paper feed counter or 1 year of use. When replacing the paper feed roller, apply grease to the paper feed shaft. GP-501MR
	2	Paper feed roller	○	-	○	-	-	○	-	-	○	
	3	Separation roller	○	-	○	-	-	○	-	-	○	
	4	Torque limiter SPF	×	-	×	-	-	×	-	-	×	Replace at 400K of the SPF paper feed counter or 2 years of use.
	5	Take-up torque limiter	×	-	×	-	-	×	-	-	×	
	6	Discharge brush	×	-	×	-	-	×	-	-	×	
	7	Registration roller	○	-	○	-	-	○	-	-	○	
	8	Transport roller 2	○	-	○	-	-	○	-	-	○	
	9	Transport roller 3	○	-	○	-	-	○	-	-	○	
	10	Paper exit roller	○	-	○	-	-	○	-	-	○	
	11	Sensors	×	-	×	-	-	×	-	-	×	
	12	Scan plate	○	-	○	-	-	○	-	-	○	
	13	Gears	×	-	×	-	-	×	-	-	×	
	14	Belts	×	-	×	-	-	×	-	-	×	
	15	OC mat	○	-	○	-	-	○	-	-	○	





## B. Scanner section

×/  : Check (Clean, replace, or adjust according to necessity.)    ○/       : Clean

▲/  : Replace    △/  : Adjust    ☆/    : Lubricate

### 18cpm machine

Unit name	Parts work sequence	Part name	When calling	80k	160k	240k	320k	400k	480k	Remark
Scanner unit	1	Drive belt	×	×	×	×	×	×	×	
	2	Drive wire	×	×	×	×	×	×	×	
	3	Sensors	×	×	×	×	×	×	×	
	4	Rails	☆	☆	☆	☆	☆	☆	☆	
	5	Mirror	○	○	○	○	○	○	○	
	6	Reflector	○	○	○	○	○	○	○	
	7	Scanner lamp	○	○	○	○	○	○	○	
	8	Lens	○	○	○	○	○	○	○	
	9	CCD	○	○	○	○	○	○	○	
	10	Table glass	○	○	○	○	○	○	○	
	11	SPF glass	○	○	○	○	○	○	○	

### 20cpm/23cpm/26cpm/31cpm machine





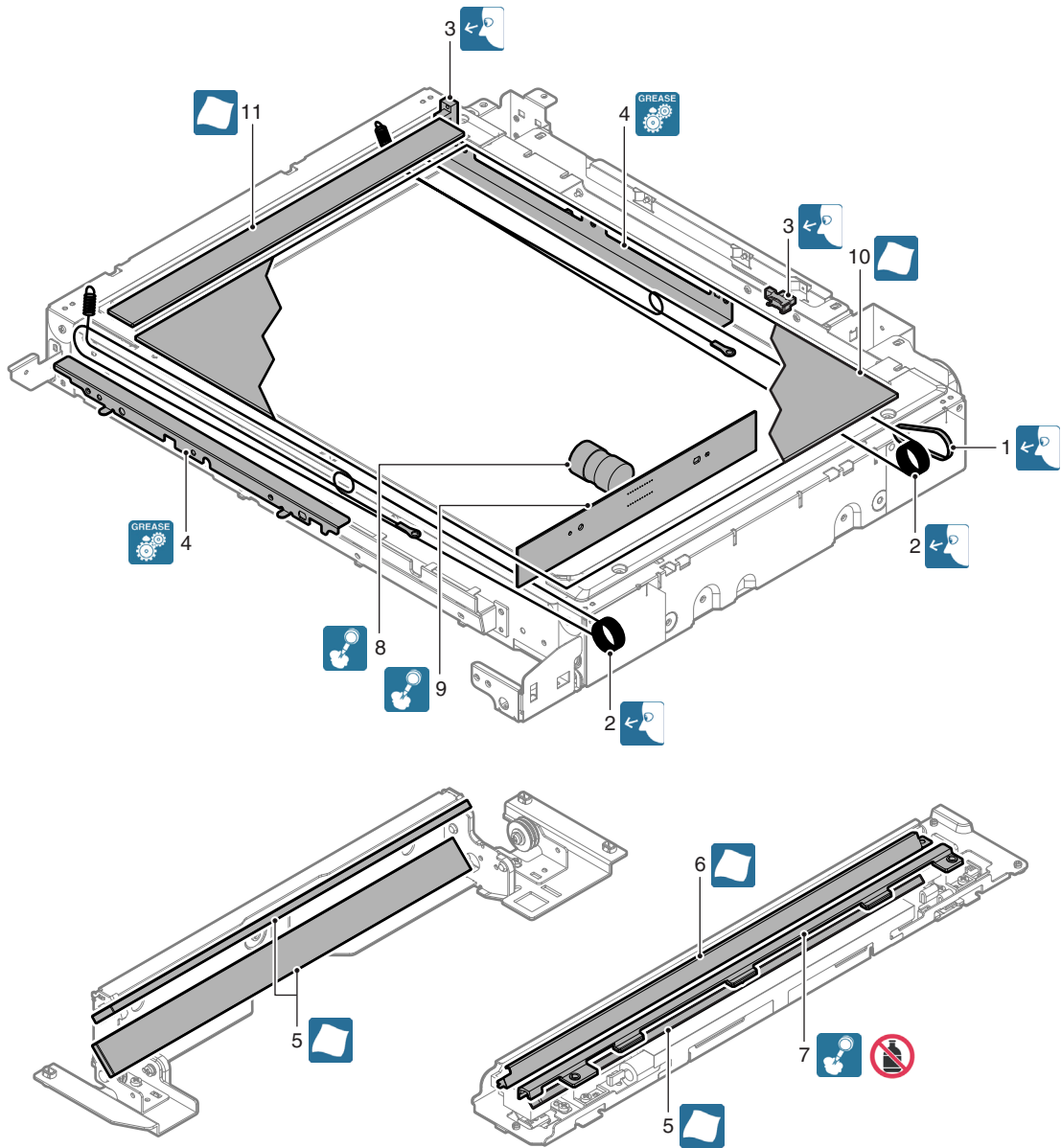

Unit name	Parts work sequence	Part name	When calling	60 K	100 K	120 K	180 K	200 K	240 K	300 K	360 K	400 K	Remark
Scanner unit	1	Drive belt	×	-	×	-	-	×	-	×	-	×	
	2	Drive wire	×	-	×	-	-	×	-	×	-	×	
	3	Sensors	×	-	×	-	-	×	-	×	-	×	
	4	Rails	☆	-	☆	-	-	☆	-	☆	-	☆	
	5	Mirror	○	-	○	-	-	○	-	○	-	○	
	6	Reflector	○	-	○	-	-	○	-	○	-	○	
	7	Scanner lamp	○	-	○	-	-	○	-	○	-	○	
	8	Lens	○	-	○	-	-	○	-	○	-	○	
	9	CCD	○	-	○	-	-	○	-	○	-	○	
	10	Table glass	○	-	○	-	-	○	-	○	-	○	
	11	SPF glass	○	-	○	-	-	○	-	○	-	○	





### 36cpm machine

Unit name	Parts work sequence	Part name	When calling	70K	120K	140K	210K	240K	280K	350K	360K	Remark
Scanner unit	1	Drive belt	×	-	×	-	-	×	-	-	×	
	2	Drive wire	×	-	×	-	-	×	-	-	×	
	3	Sensors	×	-	×	-	-	×	-	-	×	
	4	Rails	☆	-	☆	-	-	☆	-	-	☆	
	5	Mirror	○	-	○	-	-	○	-	-	○	
	6	Reflector	○	-	○	-	-	○	-	-	○	
	7	Scanner lamp	○	-	○	-	-	○	-	-	○	
	8	Lens	○	-	○	-	-	○	-	-	○	
	9	CCD	○	-	○	-	-	○	-	-	○	
	10	Table glass	○	-	○	-	-	○	-	-	○	
	11	SPF glass	○	-	○	-	-	○	-	-	○	



## C. Developing section

✕/  : Check (Clean, replace, or adjust according to necessity.)    ○/       : Clean

▲/  : Replace    △/  : Adjust    ☆/    : Lubricate

### 18cpm machine

Unit name	Parts work sequence	Part name	When calling	80k	160k	240k	320k	400k	480k	Remark
Developing unit (monochrome)	1	Developer	✕	▲	▲	▲	▲	▲	▲	
	2	DV seal	✕	✕	✕	✕	✕	✕	✕	Replace as needed.
	3	DV side seals F/R	✕	✕	✕	✕	✕	✕	✕	Replace as needed.
	4	Toner filter	✕	✕	✕	✕	✕	✕	✕	Replace as needed.
	5	Bias pin	✕	✕	✕	✕	✕	✕	✕	
	6	Connector	✕	✕	✕	✕	✕	✕	✕	

Unit name	Parts work sequence	Part name	When calling	50k	100k	150k	200k	250k	300k	Remark
Developing unit (color)	1	Developer	✕	▲	▲	▲	▲	▲	▲	
	2	DV seal	✕	✕	✕	✕	✕	✕	✕	Replace as needed.
	3	DV side seals F/R	✕	✕	✕	✕	✕	✕	✕	Replace as needed.
	4	Toner filter	✕	✕	✕	✕	✕	✕	✕	Replace as needed.
	5	Bias pin	✕	✕	✕	✕	✕	✕	✕	
	6	Connector	✕	✕	✕	✕	✕	✕	✕	

### 20cpm/23cpm/26cpm/31cpm machine





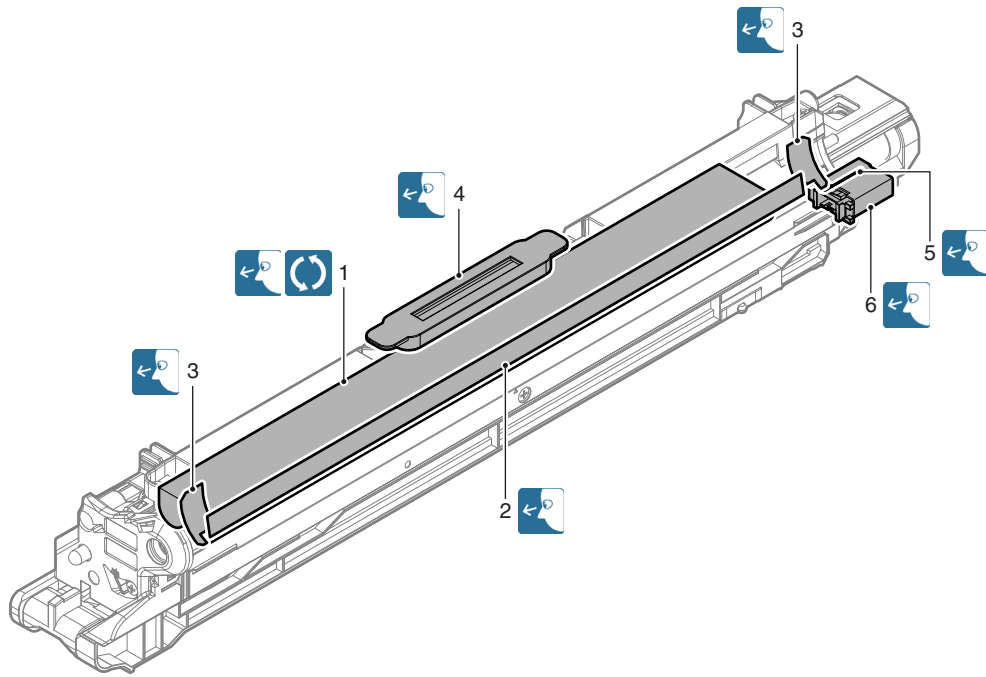

Unit name	Parts work sequence	Part name	When calling	60 K	100 K	120 K	180 K	200 K	240 K	300 K	360 K	400 K	Remark
Developing unit (monochrome)	1	Developer	✕	-	▲	-	-	▲	-	▲	-	▲	
	2	DV seal	✕	-	✕	-	-	✕	-	✕	-	✕	Replace as needed.
	3	DV side seals F/R	✕	-	✕	-	-	✕	-	✕	-	✕	
	4	Toner filter	✕	-	✕	-	-	✕	-	✕	-	✕	
	5	Bias pin	✕	-	✕	-	-	✕	-	✕	-	✕	
	6	Connector	✕	-	✕	-	-	✕	-	✕	-	✕	
Developing unit (color)	1	Developer	✕	▲	-	▲	▲	-	▲	▲	▲	-	Replace as needed.
	2	DV seal	✕	✕	-	✕	✕	-	✕	✕	✕	-	
	3	DV side seals F/R	✕	✕	-	✕	✕	-	✕	✕	✕	-	
	4	Toner filter	✕	✕	-	✕	✕	-	✕	✕	✕	-	
	5	Bias pin	✕	✕	-	✕	✕	-	✕	✕	✕	-	
	6	Connector	✕	✕	-	✕	✕	-	✕	✕	✕	-	





### 36cpm machine

Unit name	Parts work sequence	Part name	When calling	70K	120K	140K	210K	240K	280K	350K	360K	Remark
Developing unit (monochrome)	1	Developer	✕	-	▲	-	-	▲	-	-	▲	
	2	DV seal	✕	-	✕	-	-	✕	-	-	✕	Replace as needed.
	3	DV side seals F/R	✕	-	✕	-	-	✕	-	-	✕	
	4	Toner filter	✕	-	✕	-	-	✕	-	-	✕	
	5	Bias pin	✕	-	✕	-	-	✕	-	-	✕	
	6	Connector	✕	-	✕	-	-	✕	-	-	✕	
Developing unit (color)	1	Developer	✕	▲	-	▲	▲	-	▲	▲	-	Replace as needed.
	2	DV seal	✕	✕	-	✕	✕	-	✕	✕	-	
	3	DV side seals F/R	✕	✕	-	✕	✕	-	✕	✕	-	
	4	Toner filter	✕	✕	-	✕	✕	-	✕	✕	-	
	5	Bias pin	✕	✕	-	✕	✕	-	✕	✕	-	
	6	Connector	✕	✕	-	✕	✕	-	✕	✕	-	



## D. OPC drum section

✕/  : Check (Clean, replace, or adjust according to necessity.)    ○/       : Clean

▲/  : Replace    △/  : Adjust    ☆/    : Lubricate

### 18cpm machine

Unit name	Parts work sequence	Part name	When calling	80k	160k	240k	320k	400k	480k	Remark
OPC drum unit (monochrome)	1	Drum	✕	▲	▲	▲	▲	▲	▲	
	2	Cleaning blade	✕	▲	▲	▲	▲	▲	▲	
	3	Toner reception blade	✕	▲	▲	▲	▲	▲	▲	
	4	Side seals F/R	✕	✕	✕	✕	✕	✕	✕	
	5	Charger cleaner	✕	▲	▲	▲	▲	▲	▲	Integrated as a drum kit.

Unit name	Parts work sequence	Part name	When calling	50k	100k	150k	200k	250k	300k	Remark
OPC drum unit (color)	1	Drum	✕	▲	▲	▲	▲	▲	▲	
	2	Cleaning blade	✕	▲	▲	▲	▲	▲	▲	
	3	Toner reception blade	✕	▲	▲	▲	▲	▲	▲	
	4	Side seals F/R	✕	✕	✕	✕	✕	✕	✕	
	5	Charger cleaner	✕	▲	▲	▲	▲	▲	▲	Integrated as a drum kit.

### 20cpm/23cpm/26cpm/31cpm machine

Unit name	Parts work sequence	Part name	When calling	60 K	100 K	120 K	180 K	200 K	240 K	300 K	360 K	400 K	Remark
OPC drum unit (monochrome)	1	Drum	✕	-	▲	-	-	▲	-	▲	-	▲	Integrated as a drum kit (Common to monochrome and color)
	2	MC unit	✕	-	▲	-	-	▲	-	▲	-	▲	
	3	Cleaning blade	✕	-	▲	-	-	▲	-	▲	-	▲	Replace as needed.
	4	Toner reception blade	✕	-	✕	-	-	✕	-	✕	-	✕	
	5	Side seals F/R	✕	-	✕	-	-	✕	-	✕	-	✕	
	6	Charger cleaner	✕	-	▲	-	-	▲	-	▲	-	▲	Integrated as a drum kit (Common to monochrome and color)
OPC drum unit (color)	1	Drum	✕	▲	-	▲	▲	-	▲	▲	▲	-	Integrated as a drum kit (Common to monochrome and color)
	2	MC unit	✕	▲	-	▲	▲	-	▲	▲	▲	-	
	3	Cleaning blade	✕	▲	-	▲	▲	-	▲	▲	▲	-	Replace as needed.
	4	Toner reception blade	✕	✕	-	✕	✕	-	✕	✕	✕	-	
	5	Side seals F/R	✕	✕	-	✕	✕	-	✕	✕	✕	-	
	6	Charger cleaner	✕	▲	-	▲	▲	-	▲	▲	▲	-	Integrated as a drum kit (Common to monochrome and color)

### 36cpm machine

Unit name	Parts work sequence	Part name	When calling	70K	120K	140K	210K	240K	280K	350K	360K	Remark
OPC drum unit (monochrome)	1	Drum	✕	-	▲	-	-	▲	-	-	▲	Integrated as a drum kit
	2	MC unit	✕	-	▲	-	-	▲	-	-	▲	
	3	Cleaning blade	✕	-	▲	-	-	▲	-	-	▲	Replace as needed.
	4	Toner reception blade	✕	-	✕	-	-	✕	-	-	✕	
	5	Side seals F/R	✕	-	✕	-	-	✕	-	-	✕	
	6	Charger cleaner	✕	-	▲	-	-	▲	-	-	▲	Integrated as a drum kit
OPC drum unit (color)	1	Drum	✕	▲	-	▲	▲	-	▲	▲	▲	Integrated as a drum kit
	2	MC unit	✕	▲	-	▲	▲	-	▲	▲	▲	
	3	Cleaning blade	✕	▲	-	▲	▲	-	▲	▲	▲	Replace as needed.
	4	Toner reception blade	✕	✕	-	✕	✕	-	✕	✕	✕	
	5	Side seals F/R	✕	✕	-	✕	✕	-	✕	✕	✕	
	6	Charger cleaner	✕	▲	-	▲	▲	-	▲	▲	▲	Integrated as a drum kit

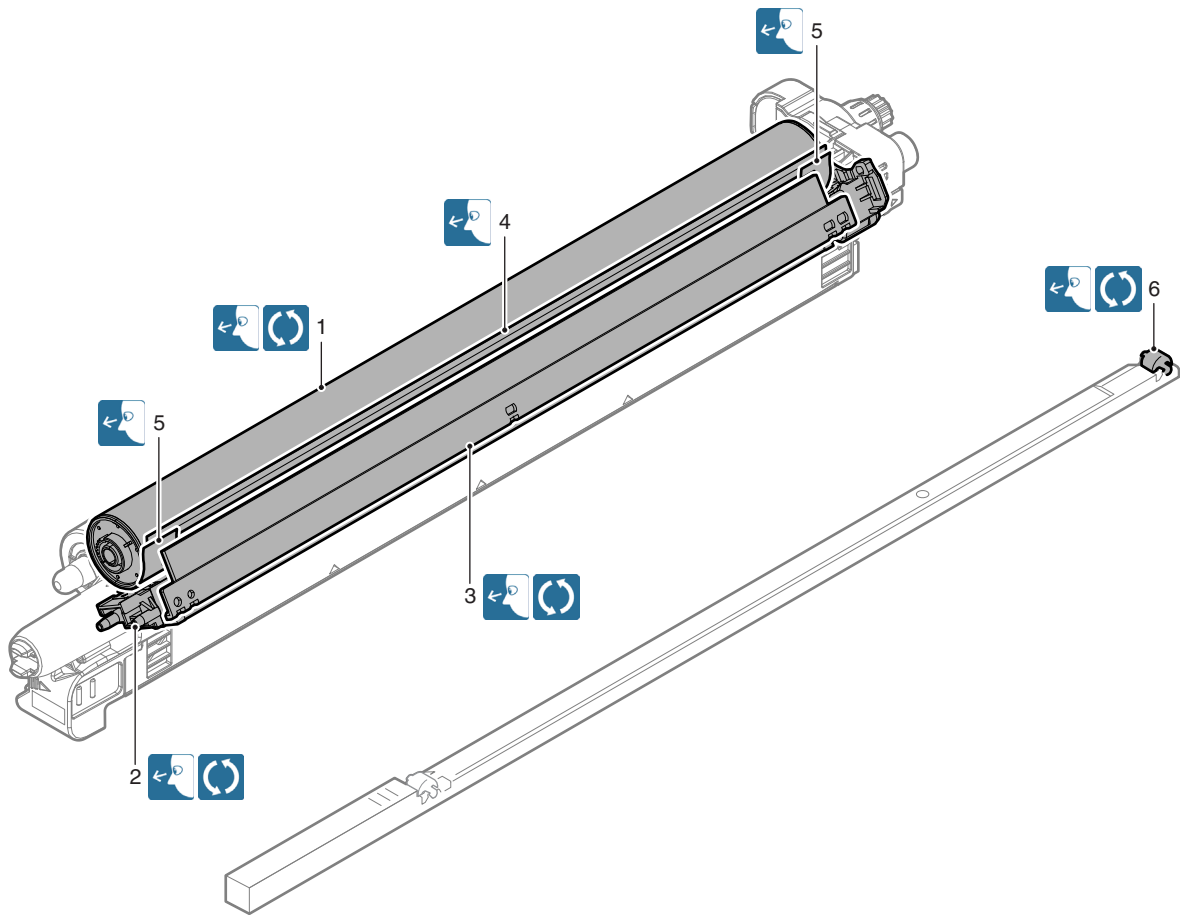

## E. Transfer section

### (1) Primary transfer unit

: Check (Clean, replace, or adjust according to necessity.)   
 : Clean  
 : Replace   
 : Adjust   
 : Lubricate

#### 18cpm machine

Unit name	Parts work sequence	Part name	When calling	80k	160k	240k	320k	400k	480k	Remark
Primary transfer unit	1	Separation pawl	-	×	×	×	×	×	×	Replace as needed.
	2	Primary transfer belt	-	▲	▲	▲	▲	▲	▲	When replacing, apply KYNAR powder.
	3	Secondary drive transmission gear	-	○	○	○	○	○	○	
	4	Primary transfer belt drive roller	-	○	○	○	○	○	○	
	5	Primary transfer belt follower roller	-	○	○	○	○	○	○	
	6	Primary transfer belt tension roller	-	○	○	○	○	○	○	
	7	Registration backup roller	-	○	○	○	○	○	○	
	8	Y auxiliary roller	-	○	○	○	○	○	○	
	9	PTC backup roller	-	○	○	○	○	○	○	
	10	Primary transfer roller	-	×	×	×	×	×	×	Replace as needed.
	11	Transfer cleaner seals F/R	-	×	×	×	×	×	×	Replace as needed.
	12	Primary transfer belt cleaner blade	-	▲	▲	▲	▲	▲	▲	
	13	Primary transfer toner reception blade	-	×	×	×	×	×	×	Replace as needed.
	14	Primary transfer operation mode detector	-	○	○	○	○	○	○	

#### 20cpm/23cpm/26cpm/31cpm machine

Unit name	Parts work sequence	Part name	When calling	60 K	100 K	120 K	180 K	200 K	240 K	300 K	360 K	400 K	Remark
Primary transfer unit	1	Separation pawl	×	-	×	-	-	×	-	×	-	×	Replace as needed.
	2	Primary transfer belt	×	-	▲	-	-	▲	-	▲	-	▲	When replacing, apply KYNAR powder.
	3	Secondary drive transmission gear	×	-	○	-	-	○	-	○	-	○	
	4	Primary transfer belt drive roller	×	-	○	-	-	○	-	○	-	○	
	5	Primary transfer belt follower roller	×	-	○	-	-	○	-	○	-	○	
	6	Primary transfer belt tension roller	×	-	○	-	-	○	-	○	-	○	
	7	Registration backup roller	×	-	○	-	-	○	-	○	-	○	
	8	Y auxiliary roller	×	-	○	-	-	○	-	○	-	○	
	9	PTC backup roller	×	-	○	-	-	○	-	○	-	○	
	10	Primary transfer roller	×	-	×	-	-	×	-	×	-	×	Replace as needed.
	11	Transfer cleaner seals F/R	×	-	×	-	-	×	-	×	-	×	
	12	Primary transfer belt cleaner blade	×	-	▲	-	-	▲	-	▲	-	▲	
	13	Primary transfer toner reception blade	×	-	×	-	-	×	-	×	-	×	Replace as needed.
	14	Primary transfer operation mode detector	×	-	○	-	-	○	-	○	-	○	





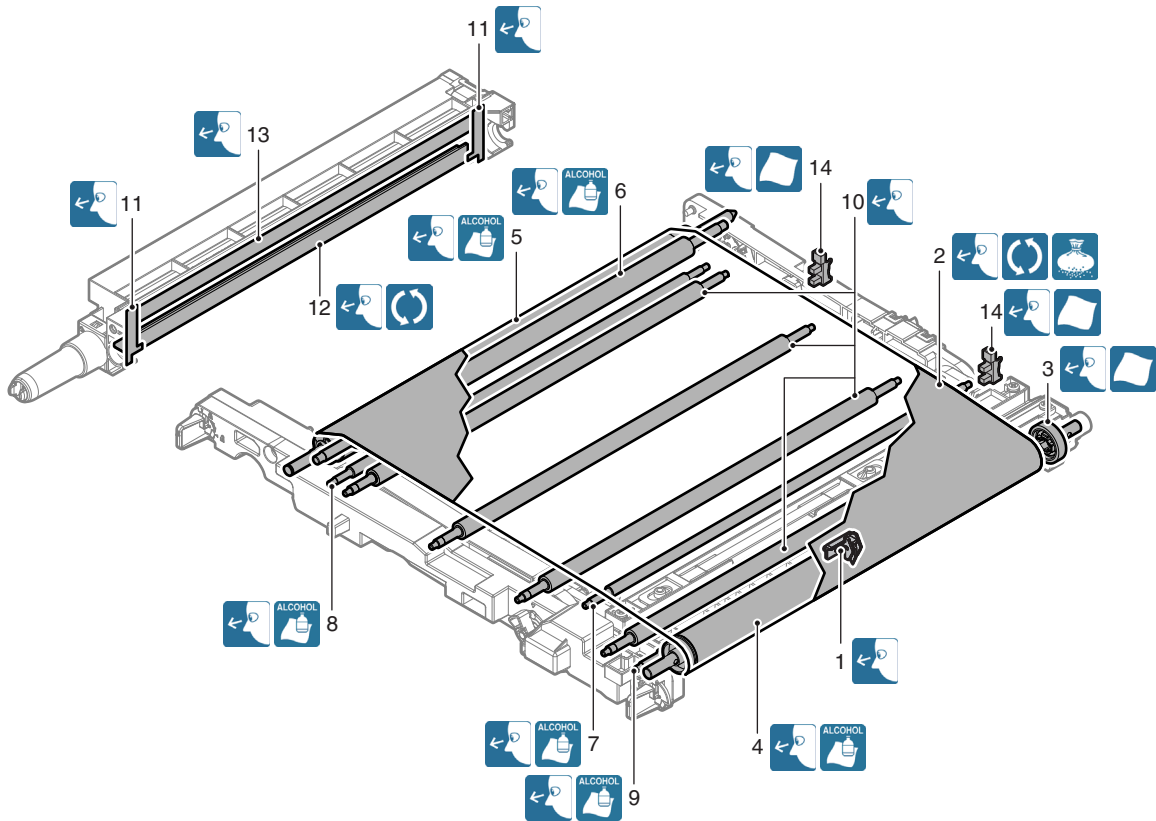

36cpm machine





Unit name	Parts work sequence	Part name	When calling	70K	120K	140K	210K	240K	280K	350K	360K	Remark
Primary transfer unit	1	Separation pawl	X	-	X	-	-	X	-	X	-	Replace as needed.
	2	Primary transfer belt	X	-	▲	-	-	▲	-	-	▲	When replacing, apply KYNAR powder.
	3	Secondary drive transmission gear	X	-	○	-	-	○	-	-	○	
	4	Primary transfer belt drive roller	X	-	○	-	-	○	-	-	○	
	5	Primary transfer belt follower roller	X	-	○	-	-	○	-	-	○	
	6	Primary transfer belt tension roller	X	-	○	-	-	○	-	-	○	
	7	Registration backup roller	X	-	○	-	-	○	-	-	○	
	8	Y auxiliary roller	X	-	○	-	-	○	-	-	○	
	9	PTC backup roller	X	-	○	-	-	○	-	-	○	
	10	Primary transfer roller	X	-	X	-	-	X	-	-	X	Replace as needed.
	11	Transfer cleaner seals F/R	X	-	X	-	-	X	-	-	X	
	12	Primary transfer belt cleaner blade	X	-	▲	-	-	▲	-	-	▲	
	13	Primary transfer toner reception blade	X	-	X	-	-	X	-	-	X	Replace as needed.
	14	Primary transfer operation mode detector	X	-	○	-	-	○	-	-	○	





## (2) Secondary transfer unit

×/  : Check (Clean, replace, or adjust according to necessity.)    ○/       : Clean

▲/  : Replace    △/  : Adjust    ☆/    : Lubricate

### 18cpm machine

Unit name	Parts work sequence	Part name	When calling	80k	160k	240k	320k	400k	480k	Remark
Secondary transfer unit	1	Secondary transfer belt follower roller	–	–	–	○	–	–	○	
	2	Secondary transfer belt	–	–	–	▲	–	–	▲	Never use alcohol or solvents for cleaning..
	3	Secondary transfer belt drive roller	–	–	–	○	–	–	○	
	4	Secondary transfer backup roller	–	–	–	○	–	–	○	
	5	Secondary transfer belt tension roller	–	–	–	○	–	–	○	
	6	Secondary transfer roller	–	–	–	×	–	–	×	Replace as needed.
	7	Secondary transfer drive gear	–	–	–	×	–	–	×	Replace as needed.
	8	Separation cam	–	–	–	☆	–	–	☆	When replacing, apply UKOG-0299FCZZ to the shaft section.
	9	Secondary transfer frame	–	–	–	☆	–	–	☆	When replacing, apply UKOG-0299FCZZ to the shaft section.

### 20cpm/23cpm/26cpm/31cpm machine





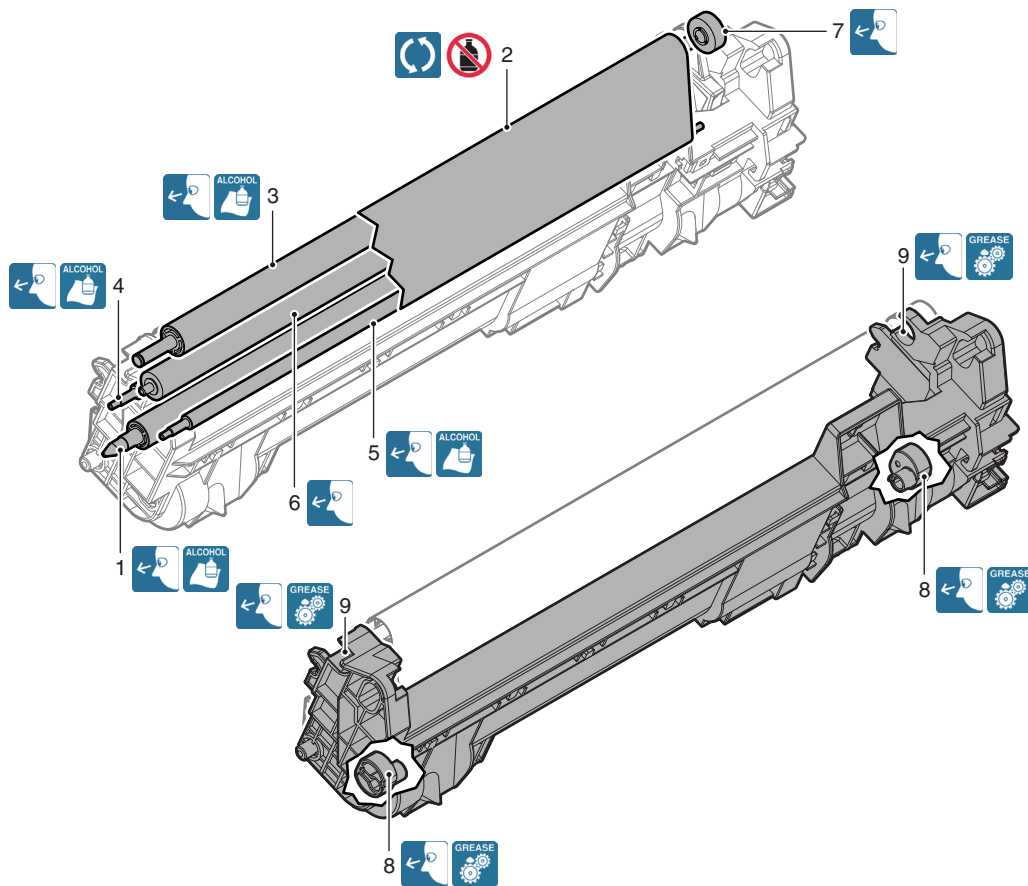

Unit name	Parts work sequence	Part name	When calling	60 K	100 K	120 K	180 K	200 K	240 K	300 K	360 K	400 K	Remark
Secondary transfer unit	1	Secondary transfer belt follower roller	×	–	–	–	–	–	–	○	–	–	
	2	Secondary transfer belt	×	–	–	–	–	–	–	▲	–	–	Never use alcohol or solvents for cleaning. Replace at every 300K.
	3	Secondary transfer belt drive roller	×	–	–	–	–	–	–	○	–	–	
	4	Secondary transfer backup roller	×	–	–	–	–	–	–	○	–	–	
	5	Secondary transfer belt tension roller	×	–	–	–	–	–	–	○	–	–	
	6	Secondary transfer roller	×	–	–	–	–	–	–	×	–	–	Replace as needed.
	7	Secondary transfer drive gear	×	–	–	–	–	–	–	×	–	–	
	8	Separation cam	×	–	–	–	–	–	–	☆	–	–	When replacing, apply HANARL FL-955R to the shaft section.
	9	Secondary transfer frame	×	–	–	–	–	–	–	☆	–	–	



### 36cpm machine

Unit name	Parts work sequence	Part name	When calling	70K	120K	140K	210K	240K	280K	350K	360K	Remark	
Secondary transfer unit	1	Secondary transfer belt follower roller	×	-	-	-	-	-	-	-	○		
	2	Secondary transfer belt	×	-	-	-	-	-	-	-	-	▲	Never use alcohol or solvents for cleaning. Replace at every 360K.
	3	Secondary transfer belt drive roller	×	-	-	-	-	-	-	-	○		
	4	Secondary transfer backup roller	×	-	-	-	-	-	-	-	○		
	5	Secondary transfer belt tension roller	×	-	-	-	-	-	-	-	○		
	6	Secondary transfer roller	×	-	-	-	-	-	-	-	×	Replace as needed.	
	7	Secondary transfer drive gear	×	-	-	-	-	-	-	-	×		
	8	Separation cam	×	-	-	-	-	-	-	-	-	☆	When replacing, apply HANARL FL-955R to the shaft section.
	9	Secondary transfer frame	×	-	-	-	-	-	-	-	-	☆	



### (3) Other

×/  : Check (Clean, replace, or adjust according to necessity.)    ○/       : Clean

▲/  : Replace    △/  : Adjust    ☆/    : Lubricate

#### 18cpm machine

Unit name	Parts work sequence	Part name	When calling	80k	160k	240k	320k	400k	480k	Remark
Other	1	PTC unit	○	▲	▲	▲	▲	▲	▲	
	2	Image density sensor/ Registration sensor/ Standard reflection plate	–	○	○	○	○	○	○	Remove dirt from the light emitting/receiving sections (transparent plastic sections) of the sensor and the standard reflection plate (gray plastic section) with dry waste cloth. *1

#### 20cpm/23cpm/26cpm/31cpm machine

Unit name	Parts work sequence	Part name	When calling	60 K	100 K	120 K	180 K	200 K	240 K	300 K	360 K	400 K	Remark
Other	1	PTC unit	×	○	▲	○	○	▲	○	▲	○	▲	
	2	Image density sensor/ Registration sensor/ Standard reflection plate	×	–	○	–	–	○	–	○	–	○	Remove dirt from the light emitting/receiving sections (transparent plastic sections) of the sensor and the standard reflection plate (gray plastic section) with dry waste cloth. *1

#### 36cpm machine

Unit name	Parts work sequence	Part name	When calling	70K	120K	140K	210K	240K	280K	350K	360K	Remark
Other	1	PTC unit	×	○	▲	○	○	▲	○	○	▲	Replace. Reciprocate the PTC cleaning rod back and forth 3 times.
	2	Image density sensor/ Registration sensor/ Standard reflection plate	×	–	○	–	–	○	–	–	○	Remove dirt from the light emitting/receiving sections (transparent plastic sections) of the sensor and the standard reflection plate (gray plastic section) with dry waste cloth. *1

\* 1: Note for cleaning the image density sensor, the registration sensor, and the standard reflection plate





When in maintenance or in case of a service call, refer to "Criteria for necessity of cleaning" below to judge the necessity of cleaning the image density sensor, the registration sensor, and the standard reflection plate. If it is judged that cleaning is necessary, then execute cleaning.

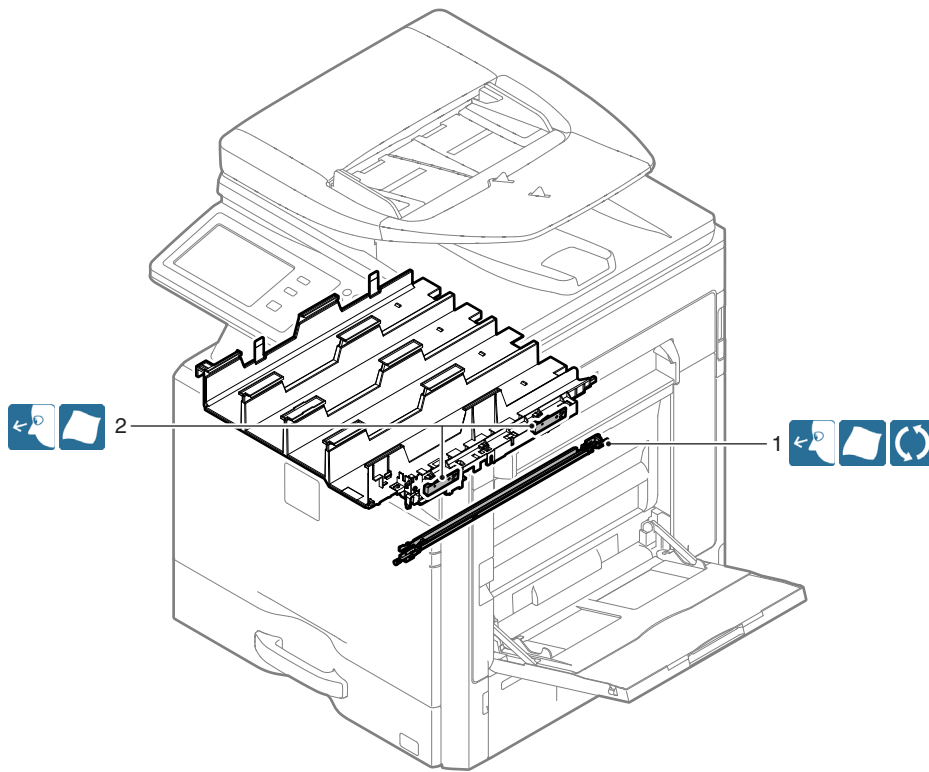



#### Criteria for necessity of cleaning

- The SIM44-2 PCS\_CL LED ADJ value is increased by aging and dirt of the image density sensor and the standard reflection plate.
- When the density of an output image is decreased and the difference between the SIM44-2 PCS\_CL LED ADJ value and the SIM44-13 PCS\_CL LED ADJ value is 30 or more, the image density sensor, the registration sensor, and the standard reflection plate may be dirtied. In this case, clean the image density sensor, the registration sensor, and the standard reflection plate with dry cloth, and perform calibration with SIM44-13 by using the calibration tool (UKOG-0318FCZZ). After completion of cleaning, use SIM46-74 ADJ 10B to adjust the copy/printer color balance.



## F. LSU section

✕/  : Check (Clean, replace, or adjust according to necessity.)    ○/       : Clean

▲/  : Replace    △/  : Adjust    ☆/    : Lubricate

### 18cpm machine

Unit name	Parts work sequence	Part name	When calling	80k	160k	240k	320k	400k	480k	Remark
LSU	1	Dust-proof glass	○	○	○	○	○	○	○	Use the LSU cleaning rod.
Other	2	Cleaning base	✕	Replace every time the waste toner box is replaced.						Attached to the waste toner box. (2 pcs.) / Replace when the waste toner box is replaced, or at 100K, or 2 years of use.

### 20cpm/23cpm/26cpm/31cpm machine

Unit name	Parts work sequence	Part name	When calling	60 K	100 K	120 K	180 K	200 K	240 K	300 K	360 K	400 K	Remark
LSU	1	Dust-proof glass	○	-	○	-	-	○	✕	○	-	○	Use the LSU cleaning rod.
Other	2	Cleaning base	✕	Replace every time the waste toner box is replaced.									Attached to the waste toner box. (2 pcs.) / Replace when the waste toner box is replaced, or at 100K, or 2 years of use.



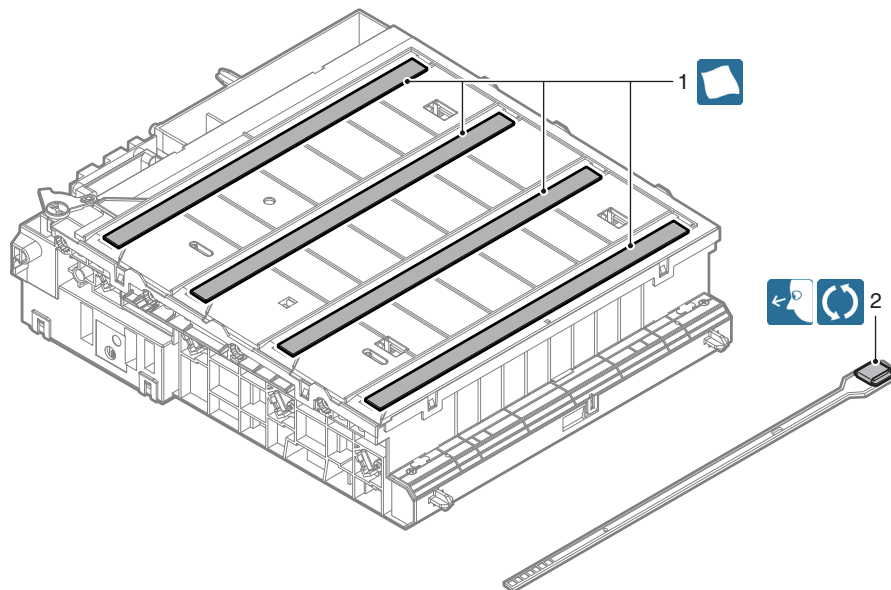

### 36cpm machine

Unit name	Parts work sequence	Part name	When calling	70K	120K	140K	210K	240K	280K	350K	360K	Remark
LSU	1	Dust-proof glass	○	-	○	-	-	○	-	-	○	Use the LSU cleaning rod.
Other	2	Cleaning base	✕	Replace every time the waste toner box is replaced.								Attached to the waste toner box. (2 pcs.) / Replace when the waste toner box is replaced, or at 100K, or 2 years of use.



## G. Manual paper feed section

×/  : Check (Clean, replace, or adjust according to necessity.)    ○/       : Clean

▲/  : Replace    △/  : Adjust    ☆/    : Lubricate

### 18cpm machine

Unit name	Parts work sequence	Part name	When calling	80k	160k	240k	320k	400k	480k	Remark
Manual paper feed unit	1	Paper feed roller	×	○	○	○	○	○	○	Replace at 80K of each paper feed counter or after 2-year use.
	2	Separation roller	×	○	○	○	○	○	○	Replace at 80K of each paper feed counter or after 3-year use.
	3	Torque limiter	×	×	×	×	×	×	×	
	4	Transport roller 9	×	○	○	○	○	○	○	
	5	Sensors	×	×	×	×	×	×	×	
	–	Paper guides	○	○	○	○	○	○	○	

### 20cpm/23cpm/26cpm/31cpm machine

Unit name	Parts work sequence	Part name	When calling	60 K	100 K	120 K	180 K	200 K	240 K	300 K	360 K	400 K	Remark
Manual paper feed unit	1	Paper feed roller	×	×	○	×	×	○	×	○	×	○	Replace at 100K of the manual paper feed counter or 1 year of use.
	2	Separation roller	×	×	○	×	×	○	×	○	×	○	
	3	Torque limiter	×	×	×	×	×	×	×	×	×	×	
	4	Transport roller 9	×	×	○	×	×	○	×	○	×	○	
	5	Sensors	×	×	×	×	×	×	×	×	×	×	
	–	Paper guides	○	×	○	×	×	○	×	○	×	○	Clean with alcohol.

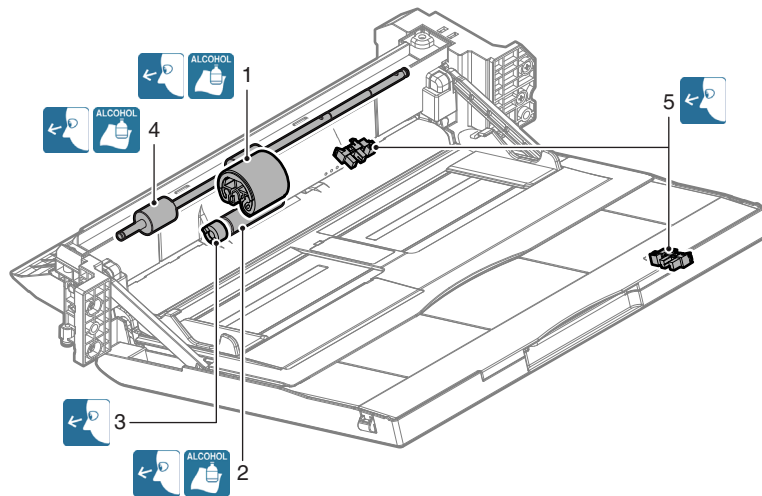





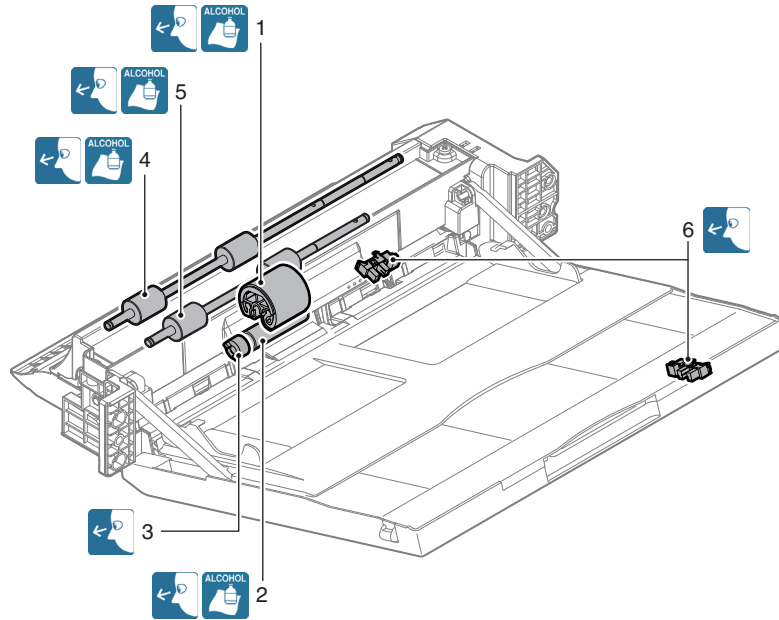





36cpm machine

Unit name	Parts work sequence	Part name	When calling	70K	120K	140K	210K	240K	280K	350K	360K	Remark
Manual paper feed unit	1	Paper feed roller	X	-	O	-	-	O	-	-	O	Replace at 100K of the manual paper feed counter or 1 year of use.
	2	Separation roller	X	-	O	-	-	O	-	-	O	
	3	Torque limiter	X	-	X	-	-	X	-	-	X	
	4	Transport roller 9	X	-	O	-	-	O	-	-	O	
	5	Transport roller 10	X	-	O	-	-	O	-	-	O	
	6	Sensors	X	-	X	-	-	X	-	-	X	
	-	Paper guides	O	-	O	-	-	O	-	-	O	Clean with alcohol.



## H. Tray paper feed section

✕/  : Check (Clean, replace, or adjust according to necessity.)    ○/      : Clean

▲/  : Replace    △/  : Adjust    ☆/    : Lubricate

### 18cpm machine

Unit name	Parts work sequence	Part name	When calling	80k	160k	240k	320k	400k	480k	Remark
Tray paper feed unit	1	Paper pickup roller	✕	○	○	○	○	○	○	Replace at 80K of each paper feed counter or after 1-year use
	2	Paper feed roller	✕	○	○	○	○	○	○	Replace at 80K of each paper feed counter or after 2-year use
	3	Separation roller	✕	○	○	○	○	○	○	Replace at 80K of each paper feed counter or after 3-year use
	4	Transport roller 4	✕	○	○	○	○	○	○	
	5	Transport roller 2	✕	○	○	○	○	○	○	
	6	Torque limiter	✕	✕	✕	✕	✕	✕	✕	
	7	Sensors	✕	✕	✕	✕	✕	✕	✕	
-	Paper guides	○	○	○	○	○	○	○		

### 20cpm/23cpm/26cpm/31cpm machine

Unit name	Parts work sequence	Part name	When calling	60 K	100 K	120 K	180 K	200 K	240 K	300 K	360 K	400 K	Remark
Tray paper feed unit	1	Paper pickup roller	✕	-	○	-	-	○	-	○	-	○	Replace at 100K of the tray paper feed counter or 1 year of use.
	2	Paper feed roller	✕	-	○	-	-	○	-	○	-	○	
	3	Separation roller	✕	-	○	-	-	○	-	○	-	○	
	4	Transport roller 4	✕	-	○	-	-	○	-	○	-	○	
	5	Transport roller 2	✕	-	○	-	-	○	-	○	-	○	
	6	Torque limiter	✕	-	✕	-	-	✕	-	✕	-	✕	
	7	Sensors	✕	-	✕	-	-	✕	-	✕	-	✕	
-	Paper guides	○	-	○	-	-	○	-	○	-	○	Clean with alcohol.	

### 36cpm machine

Unit name	Parts work sequence	Part name	When calling	70K	120K	140K	210K	240K	280K	350K	360K	Remark
Tray paper feed unit	1	Paper pickup roller	✕	-	○	-	-	○	-	-	○	Replace at 100K of the tray paper feed counter or 1 year of use.
	2	Paper feed roller	✕	-	○	-	-	○	-	-	○	
	3	Separation roller	✕	-	○	-	-	○	-	-	○	
	4	Transport roller 4	✕	-	○	-	-	○	-	-	○	
	5	Transport roller 2	✕	-	○	-	-	○	-	-	○	
	6	Torque limiter	✕	-	✕	-	-	✕	-	-	✕	
	7	Sensors	✕	-	✕	-	-	✕	-	-	✕	
-	Paper guides	○	-	○	-	-	○	-	-	○	Clean with alcohol.	

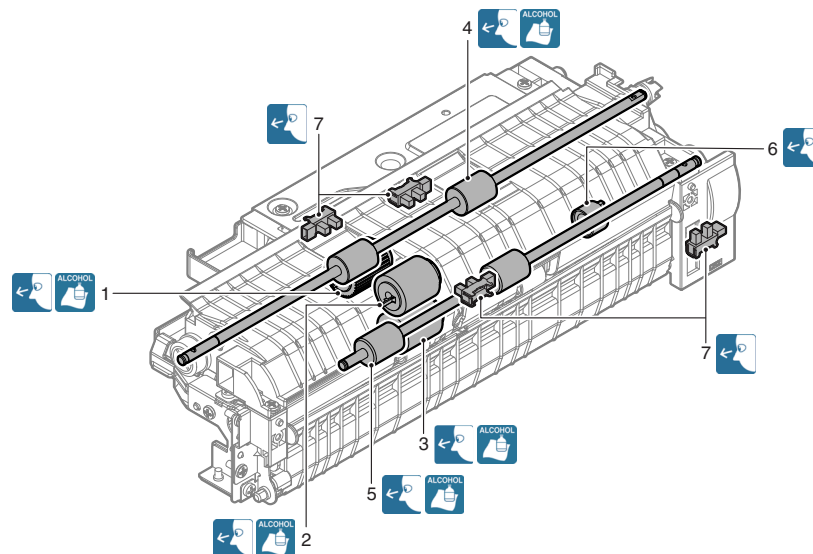



# I. Paper registration section (paper transport section)/Paper exit section/ADU section

✕/ [Icon] : Check (Clean, replace, or adjust according to necessity.)    ○/ [Icon] [Icon] [Icon] [Icon] [Icon] [Icon] : Clean

▲/ [Icon] : Replace    △/ [Icon] : Adjust    ☆/ [Icon] [Icon] [Icon] : Lubricate

## 18cpm machine

Unit name	Parts work sequence	Part name	When calling	80k	160k	240k	320k	400k	480k	Remark
PS unit	1	Registration roller (idle)	✕	○	○	○	○	○	○	
	2	Registration roller (drive)	✕	○	○	○	○	○	○	
	3	Transport roller 5	✕	○	○	○	○	○	○	
	4	Sensors								
Right door unit	5	Transport roller 7	✕	○	○	○	○	○	○	
	6	Transport roller 8	✕	○	○	○	○	○	○	
	7	Sensors								
Fusing rear unit	8	Transport roller 6	✕	○	○	○	○	○		
Paper exit unit	9	Paper exit roller 1	✕	○	○	○	○	○	○	
	10	Discharge brush	✕	✕	✕	✕	✕	✕	✕	
	11	Sensors	✕	✕	✕	✕	✕	✕	✕	
Other	12	Paper dust removing unit	○	▲	▲	▲	▲	▲	▲	
	-	Paper guides	○	○	○	○	○	○	○	

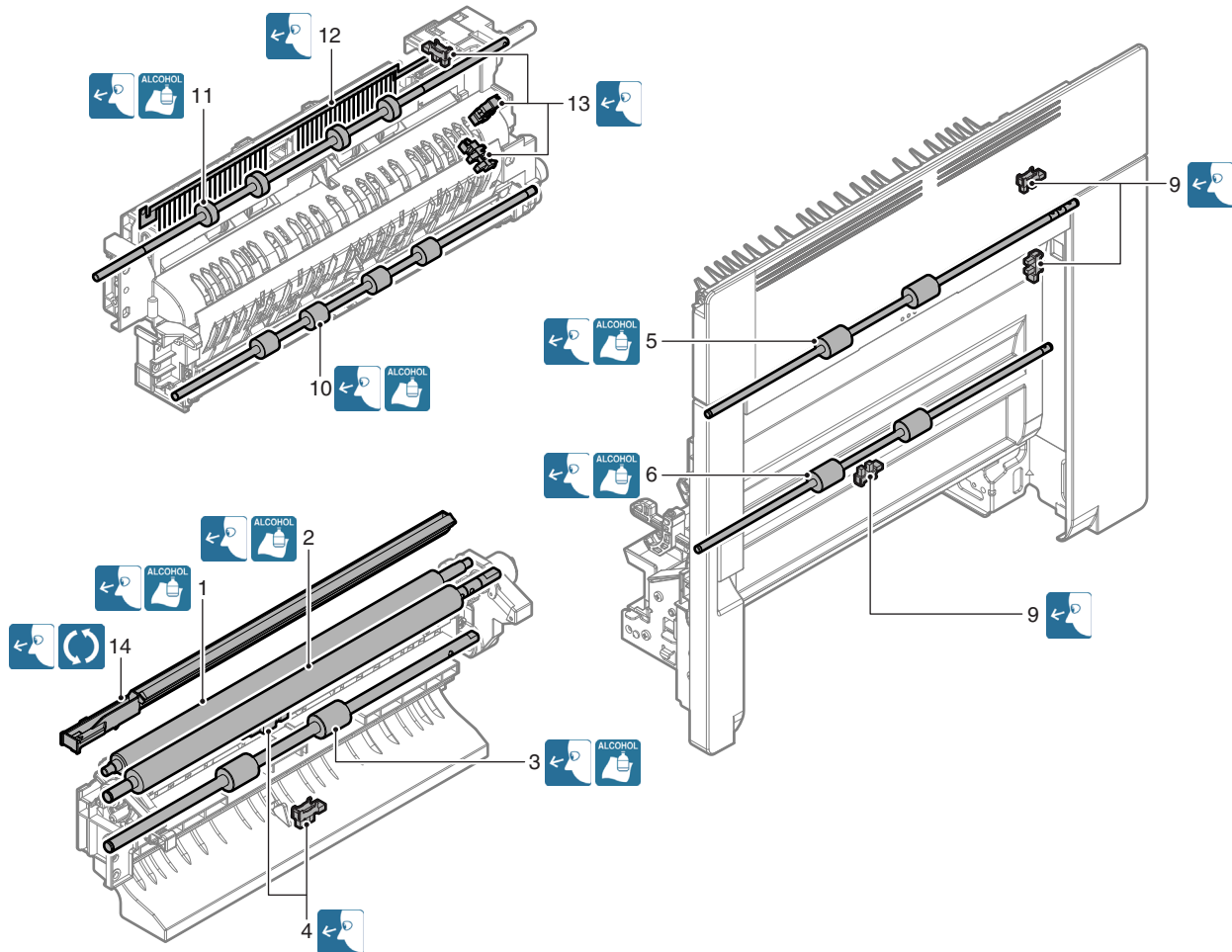

20cpm/23cpm/26cpm/31cpm machine

Unit name	Parts work sequence	Part name	When calling	60 K	100 K	120 K	180 K	200 K	240 K	300 K	360 K	400 K	Remark
PS unit	1	Registration roller (idle)	X	-	○	-	-	○	-	○	-	○	
	2	Registration roller (drive)	X	-	○	-	-	○	-	○	-	○	
	3	Transport roller 5	X	-	○	-	-	○	-	○	-	○	
	4	Sensors	X	-	X	-	-	X	-	X	-	X	
Right door unit	5	Transport roller 7	X	-	○	-	-	○	-	○	-	○	
	6	Transport roller 8	X	-	○	-	-	○	-	○	-	○	
	7	Paper exit roller 2	X	-	○	-	-	○	-	○	-	○	
	8	Discharge brush	X	-	X	-	-	X	-	X	-	X	
	9	Sensors	X	-	X	-	-	X	-	X	-	X	
Fusing rear unit	10	Transport roller 6	X	-	○	-	-	○	-	○	-	○	
Paper exit unit	11	Paper exit roller 1	X	-	○	-	-	○	-	○	-	○	
	12	Discharge brush	X	-	X	-	-	X	-	X	-	X	
	13	Sensors	X	-	X	-	-	X	-	X	-	X	
Other	14	Paper dust removing unit	○	-	▲	-	-	▲	-	▲	-	▲	
	-	Paper guides	○	-	○	-	-	○	-	○	-	○	Clean with alcohol.

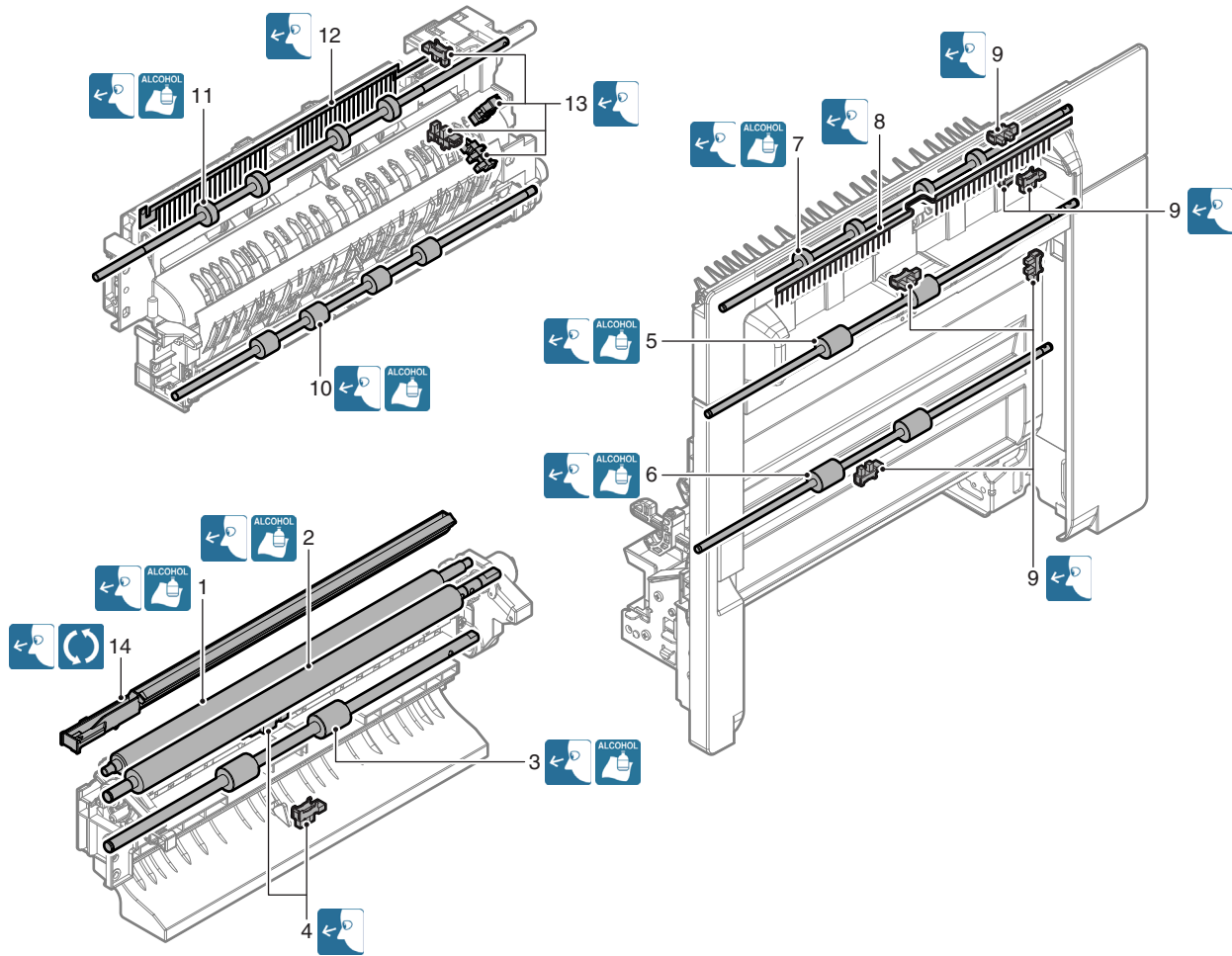





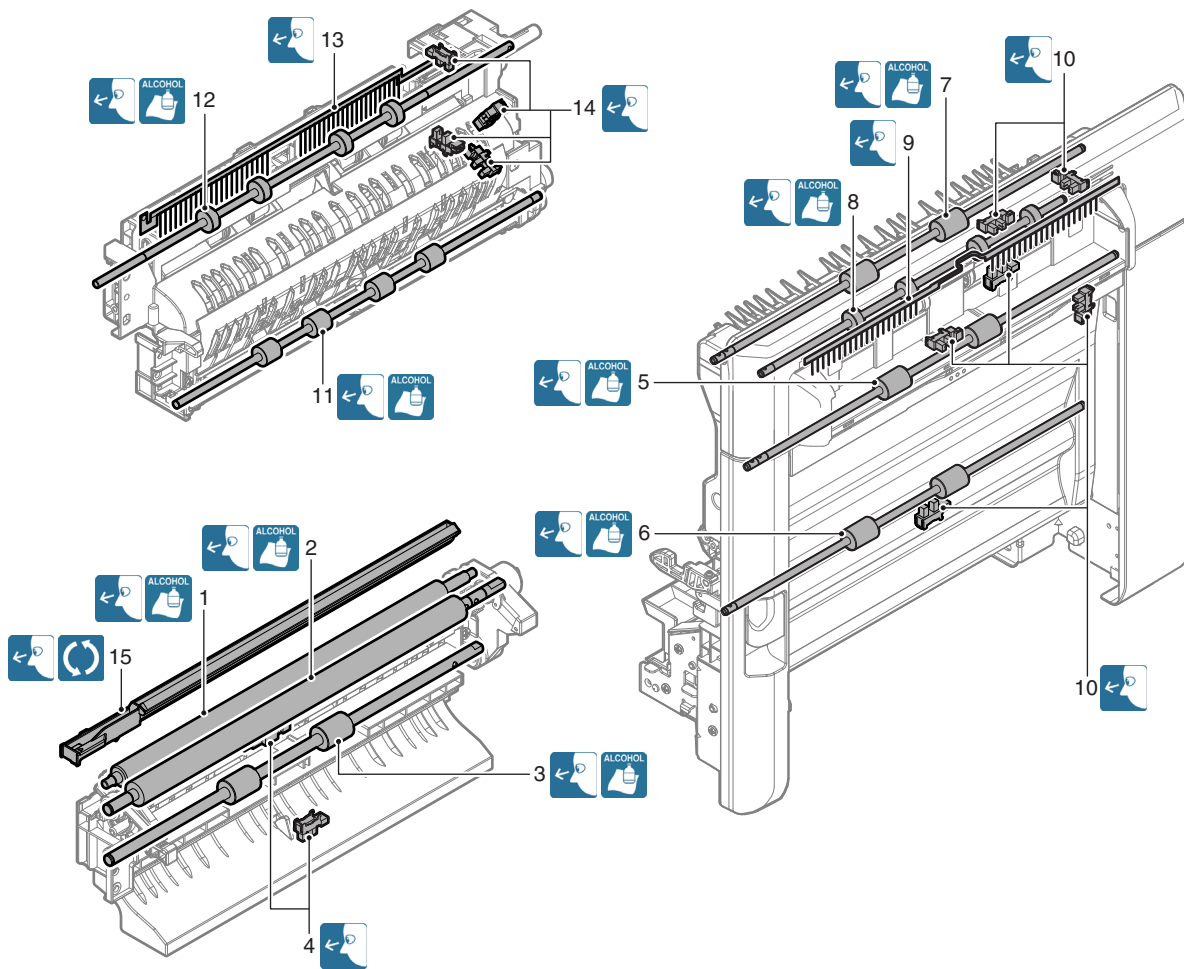



36cpm machine

Unit name	Parts work sequence	Part name	When calling	70K	120K	140K	210K	240K	280K	350K	360K	Remark
PS unit	1	Registration roller (idle)	X	-	○	-	-	○	-	-	○	
	2	Registration roller (drive)	X	-	○	-	-	○	-	-	○	
	3	Transport roller 5	X	-	○	-	-	○	-	-	○	
	4	Sensors	X	-	X	-	-	X	-	-	X	
Right door unit	5	Transport roller 7	X	-	○	-	-	○	-	-	○	
	6	Transport roller 8	X	-	○	-	-	○	-	-	○	
	7	Paper exit roller 3	X	-	○	-	-	○	-	-	○	
	8	Paper exit roller 2	X	-	○	-	-	○	-	-	○	
	9	Discharge brush	X	-	X	-	-	X	-	-	X	
Fusing rear unit	11	Transport roller 6	X	-	○	-	-	○	-	-	○	
Paper exit unit	12	Paper exit roller 1	X	-	○	-	-	○	-	-	○	
	13	Discharge brush	X	-	X	-	-	X	-	-	X	
	14	Sensors	X	-	X	-	-	X	-	-	X	
Other	15	Paper dust removing unit	○	-	▲	-	-	▲	-	-	▲	
	-	Paper guides	○	-	○	-	-	○	-	-	○	Clean with alcohol.



## J. Drive section

✕/  : Check (Clean, replace, or adjust according to necessity.)    ○/       : Clean

▲/  : Replace    △/  : Adjust    ☆/    : Lubricate

### 18cpm machine

Unit name	Parts work sequence	Part name	When calling	80k	160k	240k	320k	400k	480k	Remark
Main drive unit	1	Gears (grease)	×	×	×	×	×	×	×	Apply to the specified position when checking. FLOIL G-313S
	2	Shafts (grease)	×	×	×	×	×	×	×	
	3	Shaft earth sections (conduction grease)	×	×	×	×	×	×	×	Apply to the specified position when checking. FLOIL GE-676
	4	Belts	×	×	×	×	×	×	×	
	5	Sensors	×	×	×	×	×	×	×	
Transport drive unit	6	Belts	×	×	×	×	×	×	×	
	7	Connection arm	×	×	×	×	×	×	×	Apply to the specified position when checking. HANARL FL-955R
Fusing drive unit	8	Shafts (grease)	×	×	×	×	×	×	×	
Paper exit drive unit	9	Shafts (grease)	×	×	×	×	×	×	×	
	10	Belts	×	×	×	×	×	×	×	

### 20cpm/23cpm/26cpm/31cpm machine

Unit name	Parts work sequence	Part name	When calling	60 K	100 K	120 K	180 K	200 K	240 K	300 K	360 K	400 K	Remark
Main drive unit	1	Gears (grease)	×	-	×	-	-	×	-	×	-	×	Apply to the specified position when checking. FLOIL G-313S
	2	Shafts (grease)	×	-	×	-	-	×	-	×	-	×	
	3	Shaft earth sections (conduction grease)	×	-	×	-	-	×	-	×	-	×	Apply to the specified position when checking. FLOIL GE-676
	4	Belts	×	-	×	-	-	×	-	×	-	×	
	5	Sensors	×	-	×	-	-	×	-	×	-	×	
Transport drive unit	6	Belts	×	-	×	-	-	×	-	×	-	×	
	7	Connection arm	×	-	×	-	-	×	-	×	-	×	Apply to the specified position when checking. HANARL FL-955R
Fusing drive unit	8	Shafts (grease)	×	-	×	-	-	×	-	×	-	×	
Paper exit drive unit	9	Shafts (grease)	×	-	×	-	-	×	-	×	-	×	
	10	Belts	×	-	×	-	-	×	-	×	-	×	

- 18cpm/20cpm machine

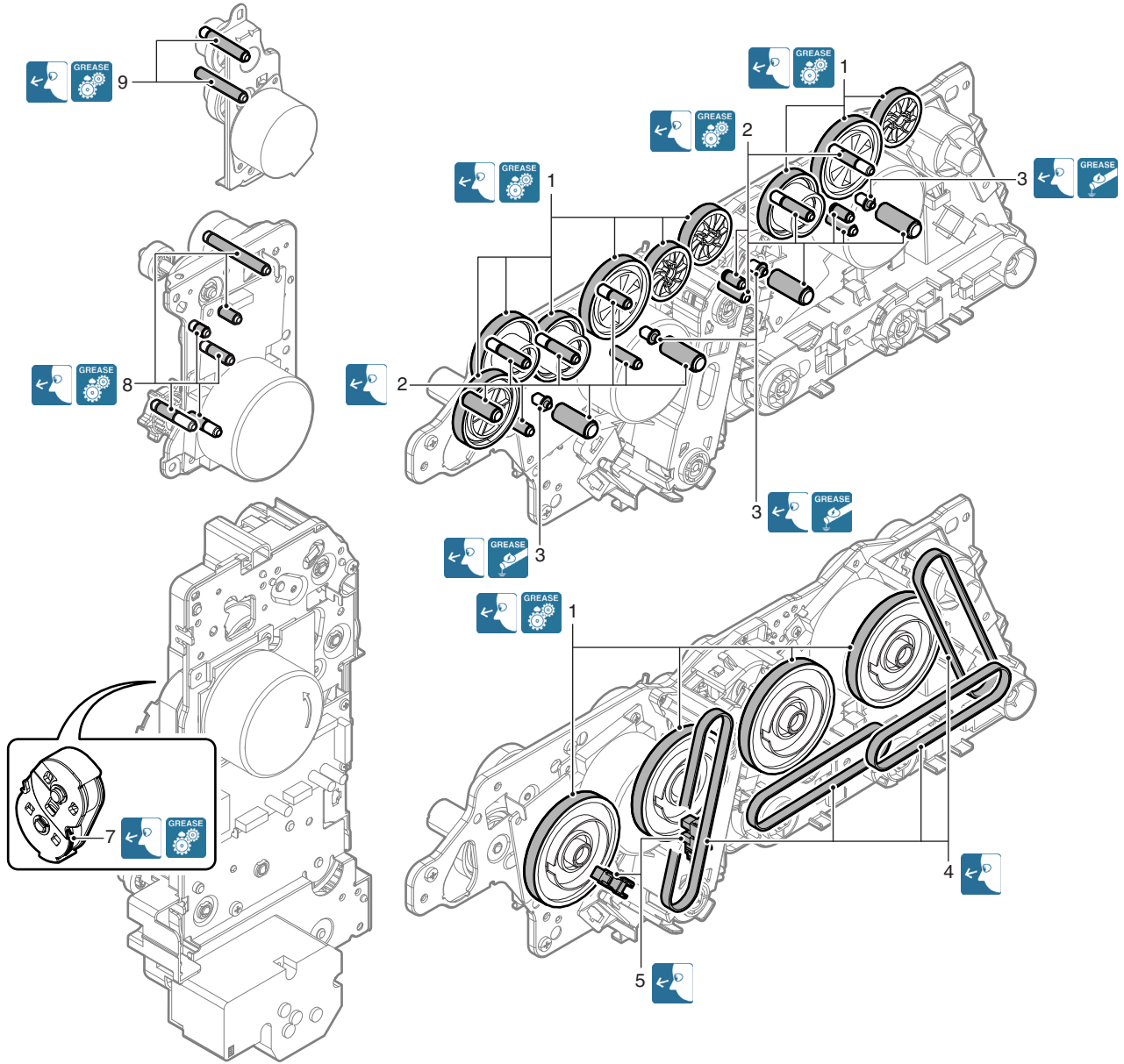

• 23cpm/26cpm/31cpm machine

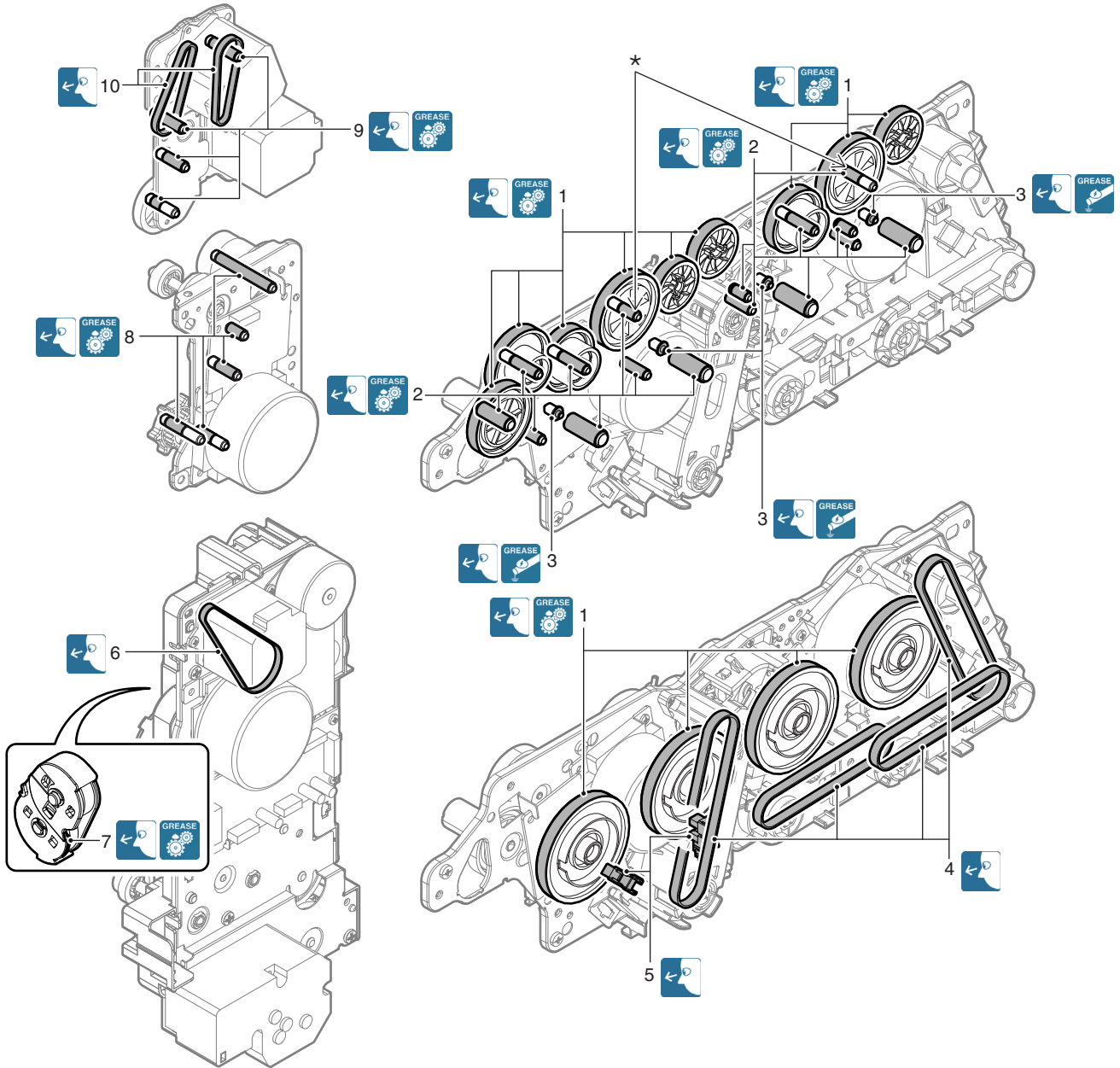





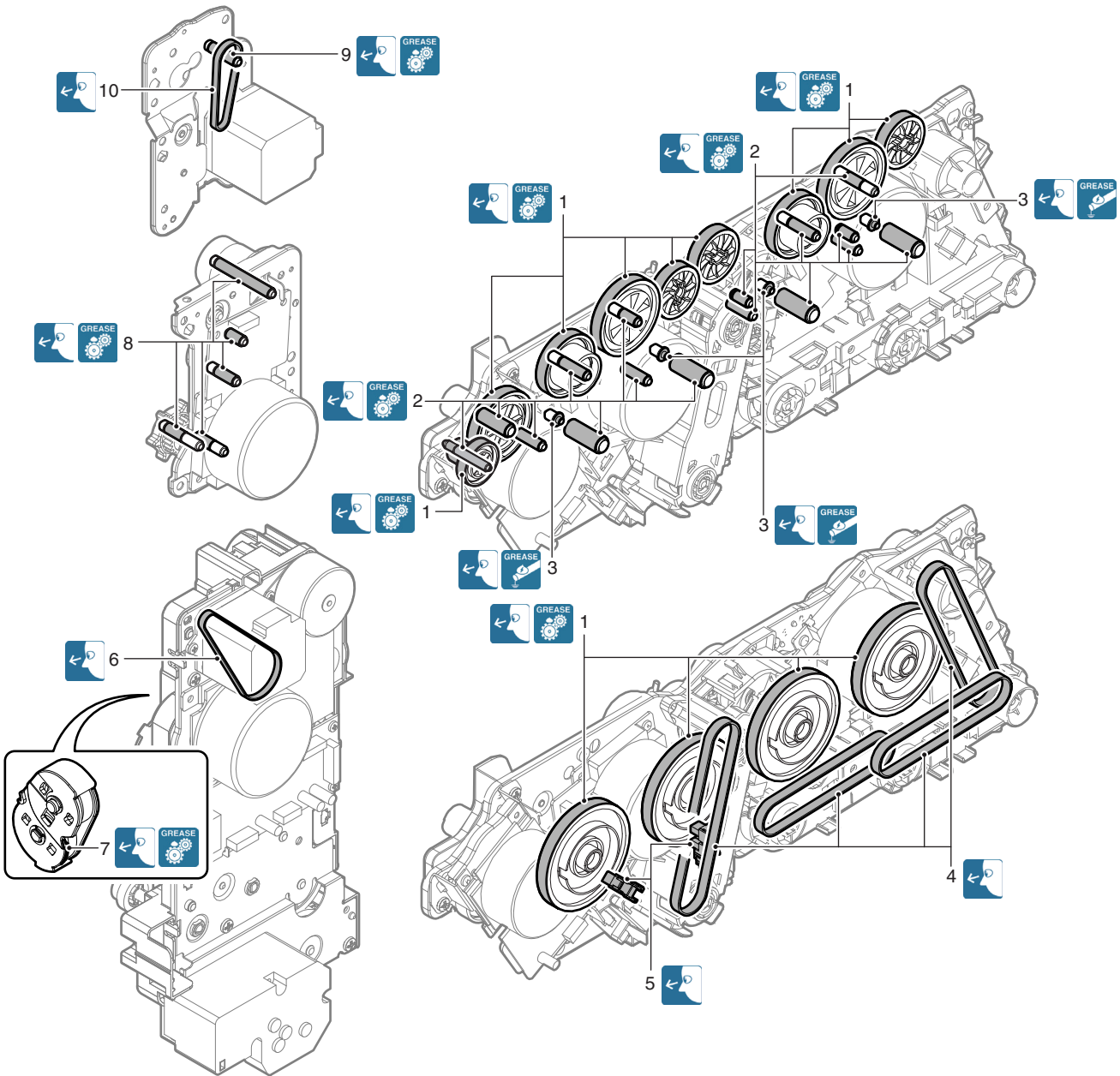

\* : For the 26cpm/31cpm machines, no need to grease up.





36cpm machine

Unit name	Parts work sequence	Part name	When calling	70K	120K	140K	210K	240K	280K	350K	360K	Remark
Main drive unit Belt drive unit	1	Gears (grease)	×	-	×	-	-	×	-	-	×	Apply to the specified position when checking. FLOIL G-313S
	2	Shafts (grease)	×	-	×	-	-	×	-	-	×	
	3	Shaft earth sections (conduction grease)	×	-	×	-	-	×	-	-	×	Apply to the specified position when checking. FLOIL GE-676
	4	Belts	×	-	×	-	-	×	-	-	×	
	5	Sensors	×	-	×	-	-	×	-	-	×	
Transport drive unit	6	Belts	×	-	×	-	-	×	-	-	×	Apply to the specified position when checking. HANARL FL-955R
	7	Connection arm	×	-	×	-	-	×	-	-	×	
Fusing drive unit	8	Shafts (grease)	×	-	×	-	-	×	-	-	×	
Paper exit drive unit	9	Shafts (grease)	×	-	×	-	-	×	-	-	×	
	10	Belts	×	-	×	-	-	×	-	-	×	



## K. Fusing section

×/  : Check (Clean, replace, or adjust according to necessity.)    ○/       : Clean

▲/  : Replace    △/  : Adjust    ☆/    : Lubricate

### 18cpm machine

Unit name	Parts work sequence	Part name	When calling	80k	160k	240k	320k	400k	480k	Remark
Fusing unit	1	Lower separation pawl	×	×	×	×	×	×	×	Replace as needed.
	2	Lower separation pawl spring	×	×	×	×	×	×	×	Replace as needed.
	3	Separation plate	×	×	×	×	×	×	×	Replace as needed.
	4	Oil applying roller	×	▲	▲	▲	▲	▲	▲	
	5	Backup roller	×	▲	▲	▲	▲	▲	▲	
	6	CL roller bearing	×	▲	▲	▲	▲	▲	▲	
	7	Lower thermistor	×	×	×	×	×	×	×	Replace as needed.
	8	Pressure roller gear	×	×	×	×	×	×	×	Replace as needed.
	9	Pressure roller bearing	×	×	×	×	×	×	×	Replace as needed.
	10	Pressure roller	×	▲	▲	▲	▲	▲	▲	Apply grease to the shaft section when replacing. (UKOG-0235FCZZ)
	11	Sub thermistor	×	×	×	×	×	×	×	Replace as needed.
	12	Heat-insulating bush	×	×	×	×	×	×	×	Replace as needed.
	13	Heating roller bearing	×	×	×	×	×	×	×	Replace as needed.
	14	Fusing roller	×	▲	▲	▲	▲	▲	▲	Apply grease to the shaft section when replacing. (UKOG-0235FCZZ)
	15	Main thermistor	×	×	×	×	×	×	×	Replace as needed.
	16	Paper guides	○	○	○	○	○	○	○	
	17	Gears	×	×	×	×	×	×	×	
	18	Lower scraper assembly	×	▲	▲	▲	▲	▲	▲	
	19	Pressure spring	×	×	×	×	×	×	×	Replace as needed.

### 20cpm machine

Unit name	Parts work sequence	Part name	When calling	60 K	100 K	120 K	180 K	200 K	240 K	300 K	360 K	400 K	Remark
Fusing unit	1	Lower separation pawl	×	-	×	-	-	×	-	×	-	×	Replace as needed.
	2	Lower separation pawl spring	×	-	×	-	-	×	-	×	-	×	
	3	Separation plate	×	-	×	-	-	×	-	×	-	×	
	4	Oil applying roller	×	-	▲	-	-	▲	-	▲	-	▲	
	5	Backup roller	×	-	▲	-	-	▲	-	▲	-	▲	
	6	CL roller bearing	×	-	▲	-	-	▲	-	▲	-	▲	
	7	Lower thermistor	×	-	×	-	-	×	-	×	-	×	Replace as needed.
	8	Pressure roller gear	×	-	×	-	-	×	-	×	-	×	
	9	Pressure roller bearing	×	-	×	-	-	×	-	×	-	×	
	10	Pressure roller	×	-	×	-	-	▲	-	×	-	▲	Apply grease to the shaft section when replacing. (JEF552) / After completion of replacement, clean the new pressure roller surface with alcohol. / Integrated with the fusing roller as a maintenance kit.
	11	Sub thermistor	×	-	×	-	-	×	-	×	-	×	Replace as needed.
	12	Heat-insulating bush	×	-	×	-	-	×	-	×	-	×	Replace as needed. / When replacing, apply grease to the inner ring section and the outer ring section. (JEF552)
	13	Heating roller bearing	×	-	×	-	-	×	-	×	-	×	Replace as needed.
	14	Fusing roller	×	-	×	-	-	▲	-	×	-	▲	Apply grease to the shaft section when replacing. (JEF552) / Integrated with the pressure roller as a maintenance kit.
	15	Main thermistor	×	-	×	-	-	×	-	×	-	×	Replace as needed.
	16	Paper guides	○	-	○	-	-	○	-	○	-	○	
	17	Gears	×	-	×	-	-	×	-	×	-	×	Replace as needed.
	18	Lower scraper assembly	×	-	▲	-	-	▲	-	▲	-	▲	
	19	Pressure spring	×	-	×	-	-	×	-	×	-	×	



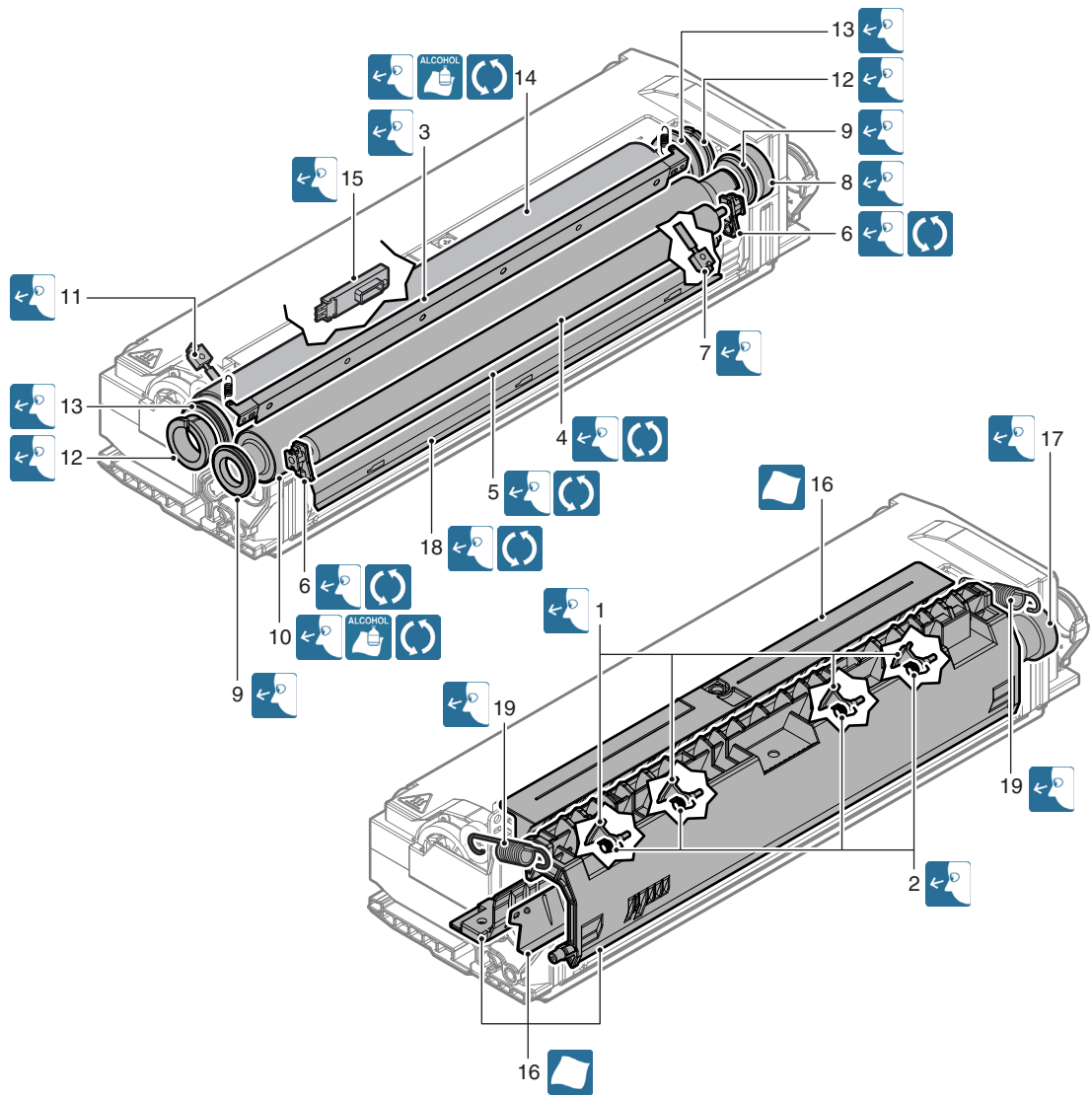

23cpm/26cpm/31cpm machine

Unit name	Parts work sequence	Part name	When calling	60 K	100 K	120 K	180 K	200 K	240 K	300 K	360 K	400 K	Remark
Fusing unit	1	Lower separation pawl	×	-	×	-	-	×	-	×	-	×	Replace as needed.
	2	Lower separation pawl spring	×	-	×	-	-	×	-	×	-	×	
	3	Separation plate	×	-	×	-	-	×	-	×	-	×	
	4	Oil applying roller	×	-	▲	-	-	▲	-	▲	-	▲	
	5	Backup roller	×	-	▲	-	-	▲	-	▲	-	▲	
	6	CL roller bearing	×	-	▲	-	-	▲	-	▲	-	▲	
	7	Lower thermistor	×	-	×	-	-	×	-	×	-	×	Replace as needed.
	8	Pressure roller gear	×	-	×	-	-	×	-	×	-	×	
	9	Pressure roller bearing	×	-	×	-	-	×	-	×	-	×	
	10	Pressure roller	×	-	×	-	-	▲	-	×	-	▲	Apply grease to the shaft section when replacing. (JEF552) / After completion of replacement, clean the new pressure roller surface with alcohol. / Integrated with the fusing roller as a maintenance kit.
	11	Sub thermistor	×	-	×	-	-	×	-	×	-	×	Replace as needed.
	12	Fusing roller bearing	×	-	×	-	-	×	-	×	-	×	
	13	Heat-insulating bush	×	-	×	-	-	×	-	×	-	×	Replace as needed. / When replacing, apply grease to the inner ring section and the outer ring section. (JEF552)
	14	Heating roller bearing	×	-	×	-	-	×	-	×	-	×	Replace as needed.
	15	Fuser belt guide collar	×	-	▲	-	-	▲	-	▲	-	▲	Integrated with the fusing belt as a maintenance kit.
	16	Fusing roller	×	-	×	-	-	▲	-	×	-	▲	Apply grease to the shaft section when replacing. (JEF552) / Integrated with the pressure roller as a maintenance kit.
	17	Heating roller	×	-	×	-	-	×	-	×	-	×	Replace as needed.
	18	Fusing belt (Except North America)	×	-	▲	-	-	▲	-	▲	-	▲	Integrated with the fuser belt guide collar as a maintenance kit. / When replacing, clean the fusing belt surface with alcohol.
		Fusing belt (North America)	×	-	-	-	-	▲	-	-	-	▲	
	19	Main thermistor	×	-	×	-	-	×	-	×	-	×	Replace as needed.
	20	Paper guides	○	-	○	-	-	○	-	○	-	○	
	21	Gears	×	-	×	-	-	×	-	×	-	×	Replace as needed.
	22	Lower scraper assembly	×	-	▲	-	-	▲	-	▲	-	▲	
	23	Pressure spring	×	-	×	-	-	×	-	×	-	×	
24	Washer	×	-	×	-	-	×	-	×	-	×		

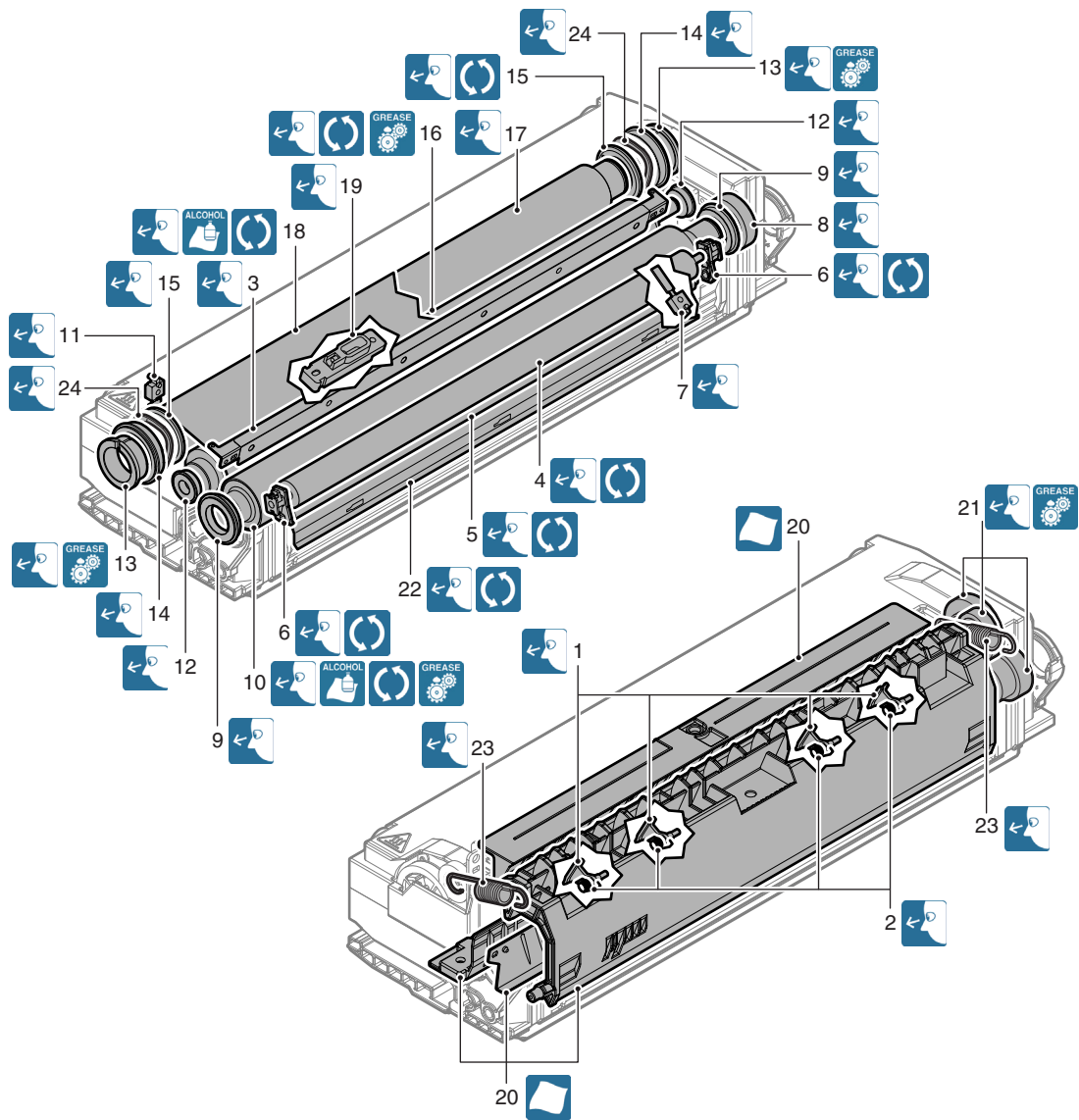





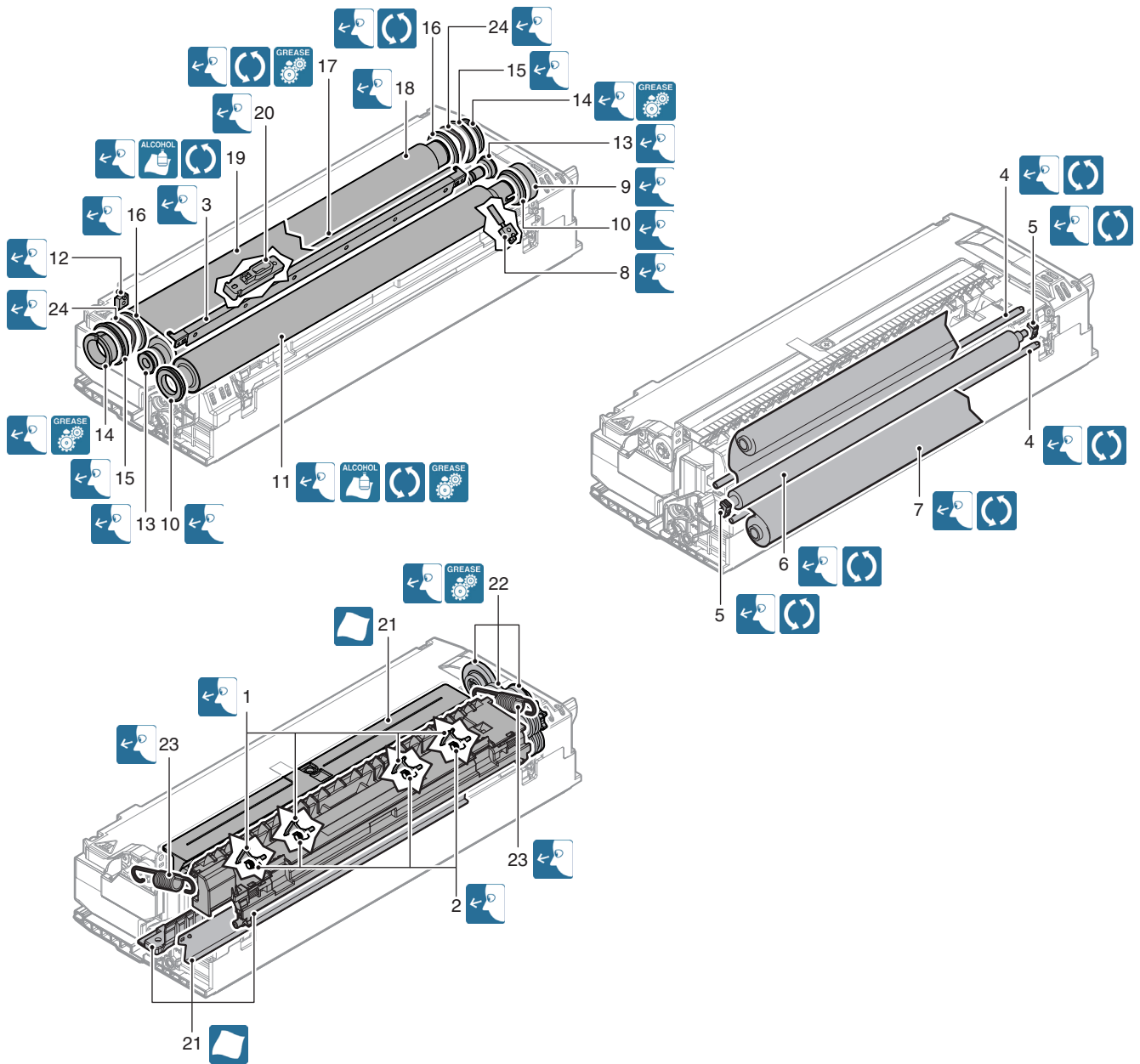







36cpm machine

Unit name	Parts work sequence	Part name	When calling	70K	120K	140K	210K	240K	280K	350K	360K	Remark
Fusing unit	1	Lower separation pawl	×	-	×	-	-	×	-	-	×	
	2	Lower separation pawl spring	×	-	×	-	-	×	-	-	×	
	3	Separation plate	×	-	×	-	-	×	-	-	×	
	4	Web guide shaft	×	-	▲	-	-	▲	-	-	▲	
	5	Web pressure roller bearing	×	-	▲	-	-	▲	-	-	▲	
	6	Web pressure roller	×	-	▲	-	-	▲	-	-	▲	
	7	Web roller	×	-	▲	-	-	▲	-	-	▲	
	8	Lower thermistor	×	-	×	-	-	×	-	-	×	Replace as needed.
	9	Pressure roller gear	×	-	×	-	-	×	-	-	×	
	10	Pressure roller bearing	×	-	×	-	-	×	-	-	×	
	11	Pressure roller	×	-	×	-	-	▲	-	-	×	Apply grease to the shaft section when replacing. (JEF552) / After completion of replacement, clean the new pressure roller surface with alcohol. / Integrated with the fusing roller as a maintenance kit. Replace at every 240K.
	12	Sub thermistor	×	-	×	-	-	×	-	-	×	Replace as needed.
	13	Fusing roller bearing	×	-	×	-	-	×	-	-	×	
	14	Heat-insulating bush	×	-	×	-	-	×	-	-	×	Replace as needed. / When replacing, apply grease to the inner ring section and the outer ring section. (JEF552)
	15	Heating roller bearing	×	-	×	-	-	×	-	-	×	Replace as needed.
	16	Fuser belt guide collar	×	-	×	-	-	▲	-	-	×	Integrated with the fusing belt as a maintenance kit. Replace at every 240K.
	17	Fusing roller	×	-	×	-	-	▲	-	-	×	Apply grease to the shaft section when replacing. (JEF552) / Integrated with the pressure roller as a maintenance kit. Replace at every 240K.
	18	Heating roller	×	-	×	-	-	×	-	-	×	Replace as needed.
	19	Fusing belt	×	-	×	-	-	▲	-	-	×	Integrated with the fuser belt guide collar as a maintenance kit. / When replacing, clean the fusing belt surface with alcohol. Replace at every 240K.
	20	Main thermistor	×	-	×	-	-	×	-	-	×	Replace as needed.
	21	Paper guides	○	-	○	-	-	○	-	-	○	
	22	Gears	×	-	×	-	-	×	-	-	×	Replace as needed.
	23	Pressure spring	×	-	×	-	-	×	-	-	×	
	24	Washer	×	-	×	-	-	×	-	-	×	



## L. Other

×/  : Check (Clean, replace, or adjust according to necessity.)    ○/       : Clean

▲/  : Replace    △/  : Adjust    ☆/    : Lubricate

### 18cpm machine

Unit name	Parts work sequence	Part name	When calling	80k	160k	240k	320k	400k	480k	Remark
	1	Ozone filter	–	▲	▲	▲	▲	▲	▲	
	2	Toner cartridge BK	User replacement for every toner empty.							
	3	Toner cartridge C								
	4	Toner cartridge M								
	5	Toner cartridge Y								
	6	Waste toner box	Replaced by the user when full is detected.							Replacement reference: 50K

### 20cpm/23cpm/26cpm/31cpm machine

Unit name	Parts work sequence	Part name	When calling	60 K	100 K	120 K	180 K	200 K	240 K	300 K	360 K	400 K	Remark
	1	Ozone filter	–	–	▲	–	–	▲	–	▲	–	▲	
	2	Toner cartridge BK	User replacement for every toner empty.										
	3	Toner cartridge C											
	4	Toner cartridge M											
	5	Toner cartridge Y											
	6	Waste toner box	Replaced by the user when full is detected.										Replacement reference: 50K





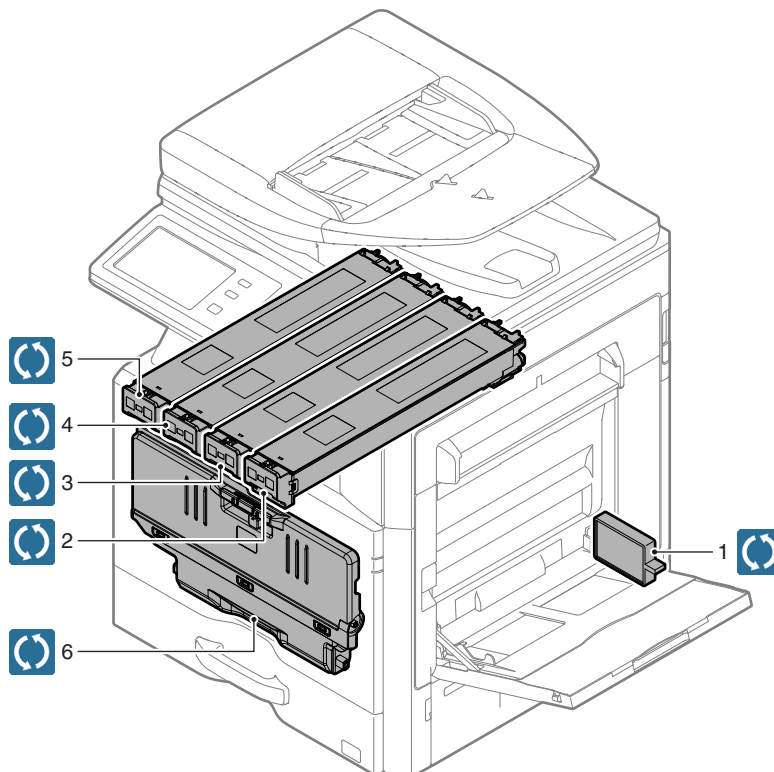





### 36cpm machine

Unit name	Parts work sequence	Part name	When calling	70K	120K	140K	210K	240K	280K	350K	360K	Remark	
	1	Ozone filter	–	–	▲	–	–	▲	–	–	▲		
	2	Toner cartridge BK	User replacement for every toner empty.										
	3	Toner cartridge C											
	4	Toner cartridge M											
	5	Toner cartridge Y											
	6	Waste toner box	Replaced by the user when full is detected.										Replacement reference: 50K



## M. Option

### (1) Stand/500 sheet paper drawer

✕/  : Check (Clean, replace, or adjust according to necessity.)   
 ○/       : Clean  
 ▲/  : Replace   
 △/  : Adjust   
 ☆/    : Lubricate

Unit work sequence	Unit name	Parts work sequence	Part name	When calling	At the machine cycle	Remark
1	Tray 2 paper feed unit	1	Paper pickup roller	✕	○	Replace at 100K of each tray paper feed counter or 1 year of use.
		2	Paper feed roller	✕	○	
		3	Separation roller	✕	○	
		4	Transport roller 1	✕	○	
		5	Torque limiter	✕	✕	Replace at 100K of each tray paper feed counter.
		6	Sensors	✕	✕	
		-	Paper guides	○	○	Clean with alcohol.
2	1CS drive unit	7	Gears (grease)	✕	✕	Apply to the specified position when checking. HANARL FL-955R
		8	Shafts (grease)	✕	✕	Apply to the specified position when checking. FLOIL G-313S

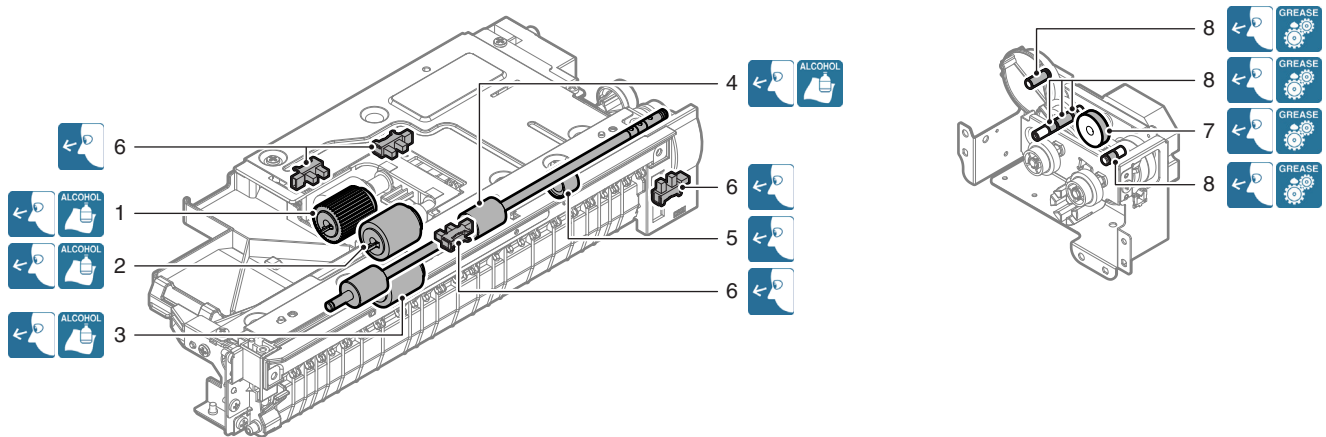

## (2) Stand/2x500 sheet paper drawer





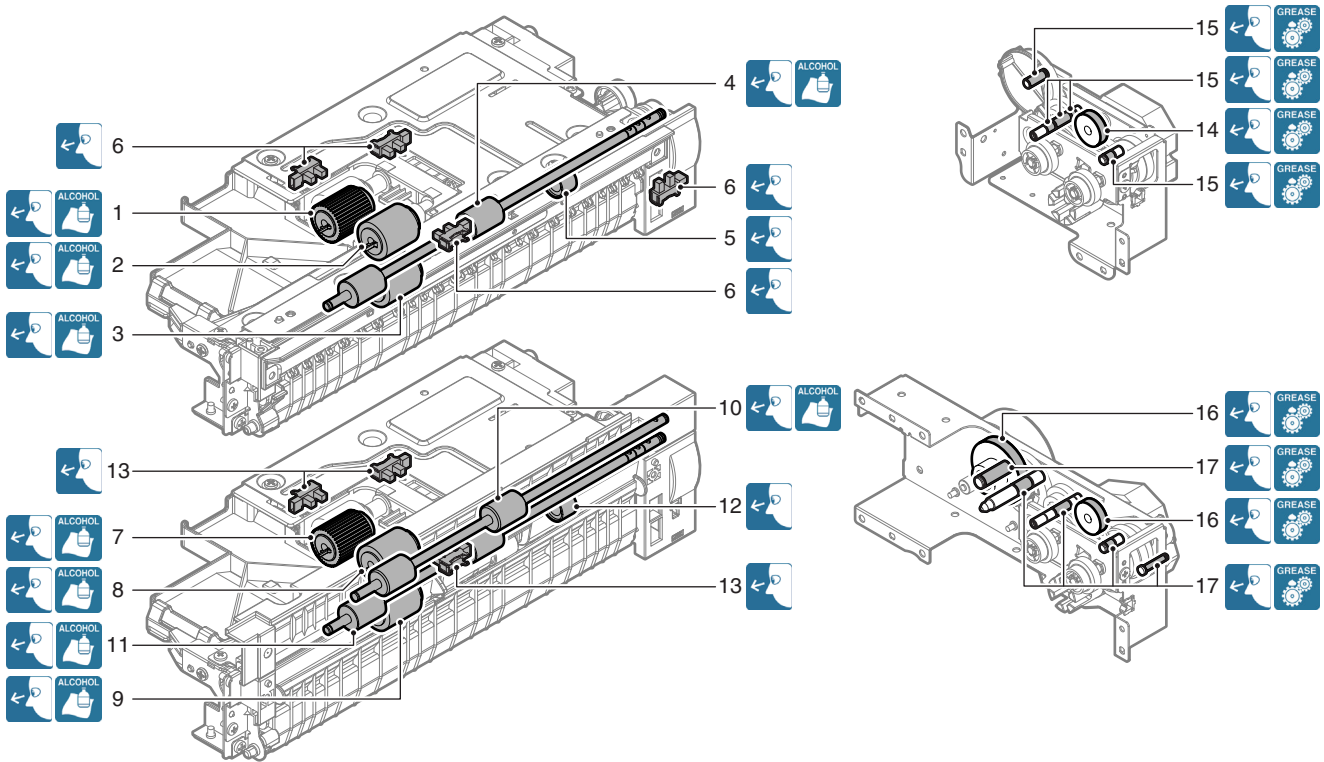







✕/ : Check (Clean, replace, or adjust according to necessity.)    ○/ : Clean  
 ▲/ : Replace    △/ : Adjust    ☆/ : Lubricate

Unit work sequence	Unit name	Parts work sequence	Part name	When calling	At the machine cycle	Remark
1	Tray 2 paper feed unit	1	Paper pickup roller	✕	○	Replace at 100K of each tray paper feed counter or 1 year of use.
		2	Paper feed roller	✕	○	
		3	Separation roller	✕	○	
		4	Transport roller 1	✕	○	
		5	Torque limiter	✕	✕	Replace at 100K of each tray paper feed counter.
		6	Sensors	✕	✕	
		–	Paper guides	○	○	Clean with alcohol.
2	Tray 3 paper feed unit	7	Paper pickup roller	✕	○	Replace at 100K of each tray paper feed counter or 1 year of use.
		8	Paper feed roller	✕	○	
		9	Separation roller	✕	○	
		10	Vertical transport roller 1	✕	○	
		11	Transport roller 3	✕	○	
		12	Torque limiter	✕	✕	Replace at 100K of each tray paper feed counter.
		13	Sensors	✕	✕	
		–	Paper guides	○	○	Clean with alcohol.
3	1CS drive unit	14	Gears (grease)	✕	✕	Apply to the specified position when checking. HANARL FL-955R
		15	Shafts (grease)	✕	✕	Apply to the specified position when checking. FLOIL G-313S
4	2CS drive unit	16	Gears (grease)	✕	✕	Apply to the specified position when checking. HANARL FL-955R
		17	Shafts (grease)	✕	✕	Apply to the specified position when checking. FLOIL G-313S











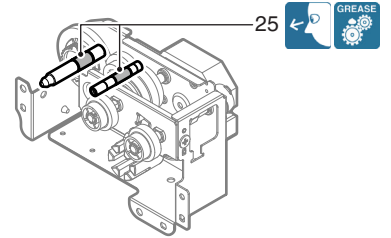
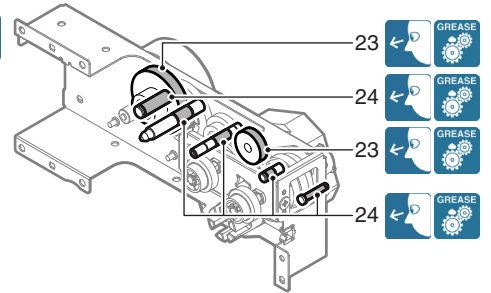
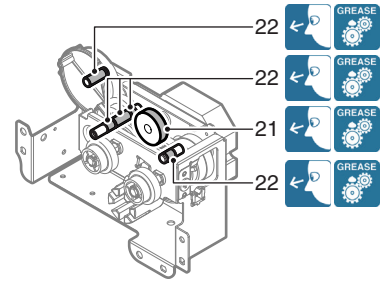
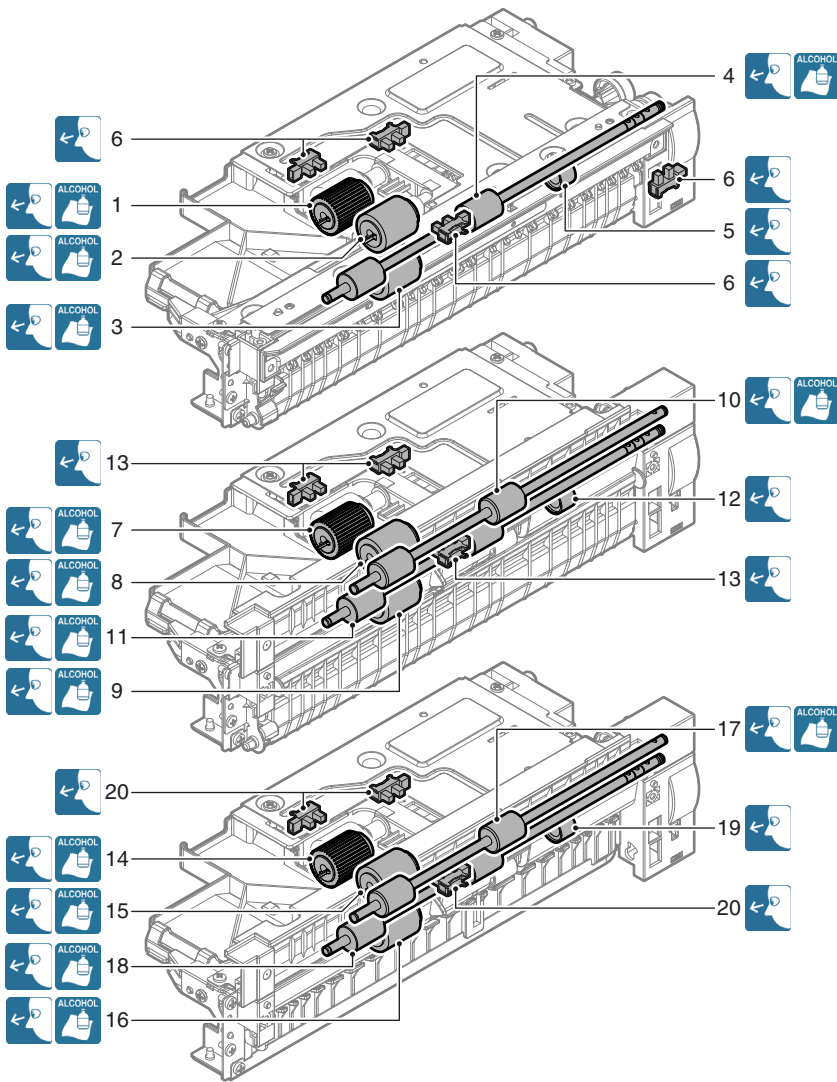

### (3) Stand/3x500 sheet paper drawer





✕/  : Check (Clean, replace, or adjust according to necessity.)   
 ○/       : Clean  
 ▲/  : Replace   
 △/  : Adjust   
 ☆/    : Lubricate

Unit work sequence	Unit name	Parts work sequence	Part name	When calling	At the machine cycle	Remark
1	Tray 2 paper feed unit	1	Paper pickup roller	✕	○	Replace at 100K of each tray paper feed counter or 1 year of use.
		2	Paper feed roller	✕	○	
		3	Separation roller	✕	○	
		4	Transport roller 1	✕	○	
		5	Torque limiter	✕	✕	Replace at 100K of each tray paper feed counter.
		6	Sensors	✕	✕	
		–	Paper guides	○	○	Clean with alcohol.
2	Tray 3 paper feed unit	7	Paper pickup roller	✕	○	Replace at 100K of each tray paper feed counter or 1 year of use.
		8	Paper feed roller	✕	○	
		9	Separation roller	✕	○	
		10	Vertical transport roller 1	✕	○	
		11	Transport roller 3	✕	○	
		12	Torque limiter	✕	✕	Replace at 100K of each tray paper feed counter.
		13	Sensors	✕	✕	
		–	Paper guides	○	○	Clean with alcohol.
3	Tray 4 paper feed unit	14	Paper pickup roller	✕	○	Replace at 100K of each tray paper feed counter or 1 year of use.
		15	Paper feed roller	✕	○	
		16	Separation roller	✕	○	
		17	Vertical transport roller 2	✕	○	
		18	Transport roller 5	✕	○	
		19	Torque limiter	✕	✕	Replace at 100K of each tray paper feed counter.
		20	Sensors	✕	✕	
		–	Paper guides	○	○	Clean with alcohol.
4	1CS drive unit	21	Gears (grease)	✕	✕	Apply to the specified position when checking. HANARL FL-955R
		22	Shafts (grease)	✕	✕	Apply to the specified position when checking. FLOIL G-313S
5	2CS drive unit	23	Gears (grease)	✕	✕	Apply to the specified position when checking. HANARL FL-955R
		24	Shafts (grease)	✕	✕	Apply to the specified position when checking. FLOIL G-313S
6	3CS drive unit	25	Shafts (grease)	✕	✕	Apply to the specified position when checking. FLOIL G-313S



#### (4) Large capacity tray





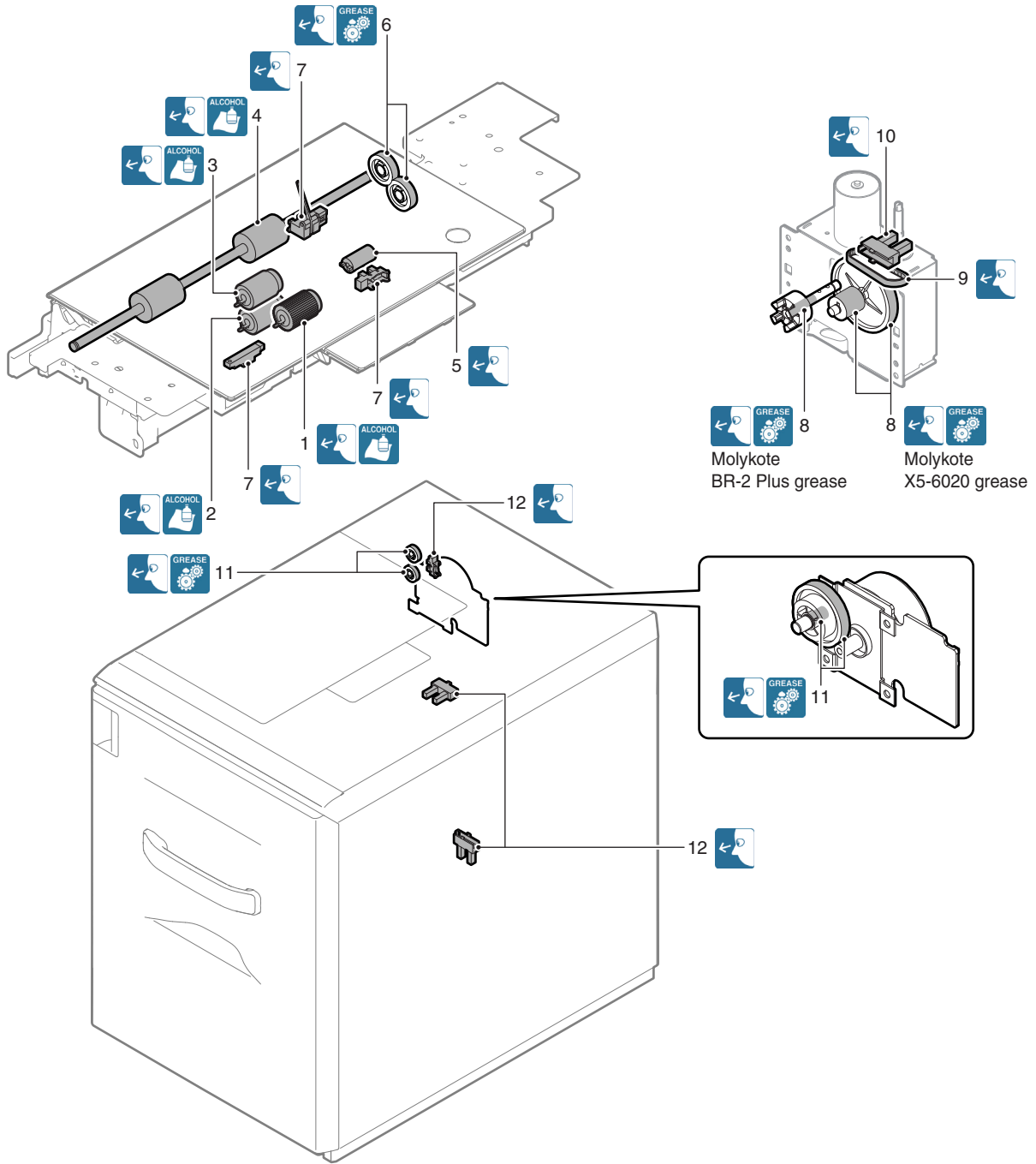

×/  : Check (Clean, replace, or adjust according to necessity.)    ○/       : Clean





▲/  : Replace    △/  : Adjust    ☆/    : Lubricate

Unit work sequence	Unit name	Parts work sequence	Part name	When calling	At the machine cycle	Remark
1	Paper feed unit	1	Paper pickup roller	×	○	As a rough guide, these rollers should be replaced when each tray paper feed counter reaches a value of 100K or when one year has elapsed since the start of use.
		2	Paper feed roller	×	○	
		3	Separation roller	×	○	
		4	Torque limiter	×	×	As a rough guide, the torque limiter should be replaced when each tray paper feed counter reaches a value of 800K.
		5	Transport roller	×	○	
		6	Each gear (grease)	×	×	When checking, apply to the specified positions. HANARL FL-955R
		7	Each sensor	×	×	
		–	Each paper guide	○	○	Clean with alcohol.
2	Drive unit	8	Each gear (grease)	×	×	When checking, apply to the specified positions. MOLYKOTE X5-6020 MOLYKOTE BR-2 Plus
		9	Each belt	×	×	
		10	Each sensor	×	×	
3	Other	11	Each gear (grease)	×	×	When checking, apply to the specified positions. MOLYKOTE X5-6020
		12	Each sensor	×	×	



## (5) Finisher

×/  : Check (Clean, replace, or adjust according to necessity.)    ○/       : Clean

▲/  : Replace    △/  : Adjust    ☆/    : Lubricate

Parts work sequence	Part name	When calling	At the machine cycle	Remark
1	Staple cartridge	×	×	Replacement is made by the user at every 5,000 pcs.
2	Staple unit	×	×	Replacement reference: Replace the unit at every 200K staple.
3	Paddle	×	○	
4	Inlet port paper transport roller	×	○	
5	Inlet port paper transport roller B	×	○	
6	Discharge brush	×	×	
7	Paper exit roller B	×	○	
8	Paper exit roller	×	○	
9	Bundle exit paper transport roller	×	○	
10	Bundle exit paper exit transport roller B	×	○	
11	Scraping roller	×	○	Replacement reference: Replace at every 1000K of the finisher paper exit count value.
12	Sensors	×	×	
-	Paper guides	×	○	Clean with alcohol.

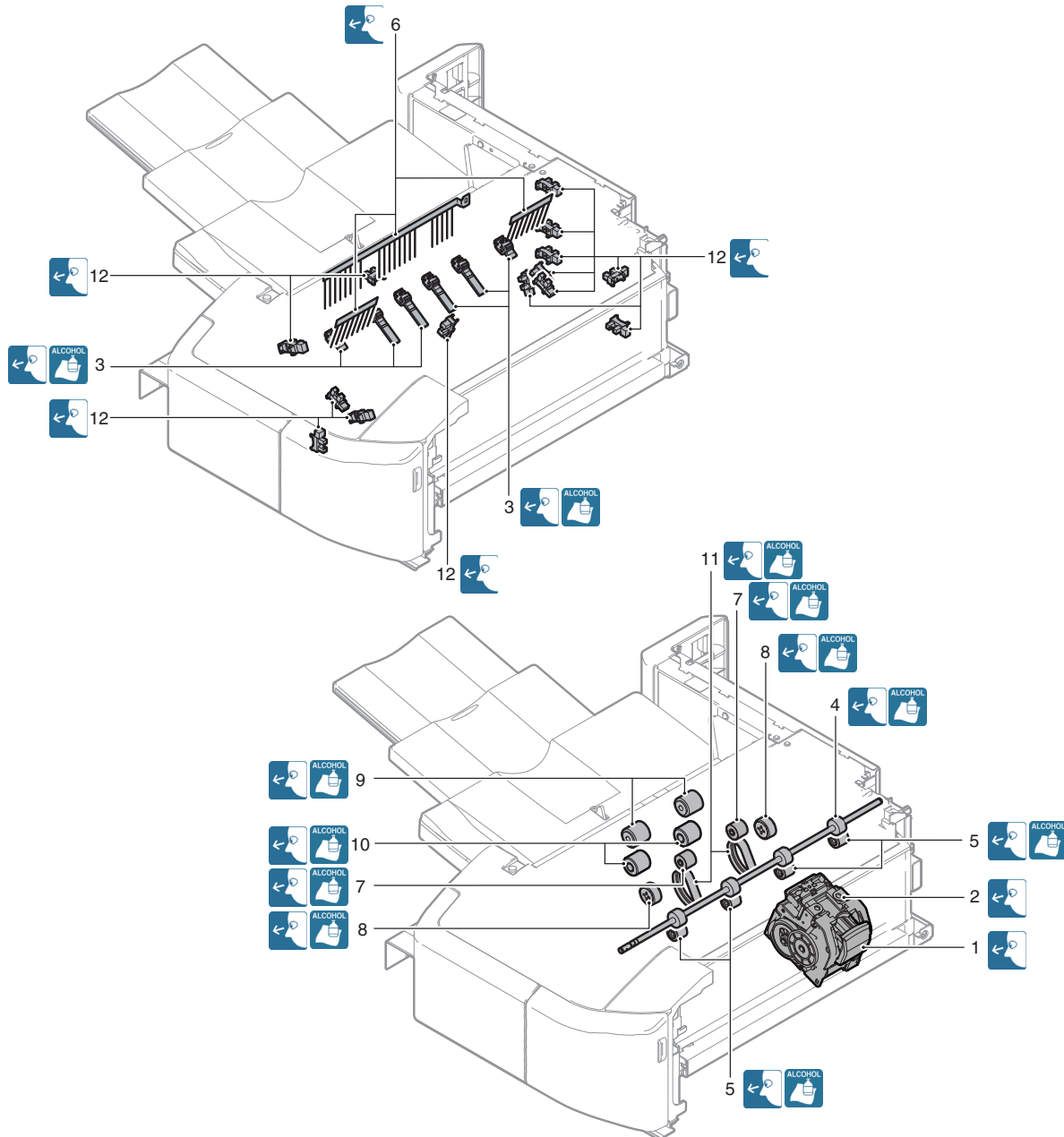

## (6) Punch unit



×/  : Check (Clean, replace, or adjust according to necessity.)    ○/       : Clean

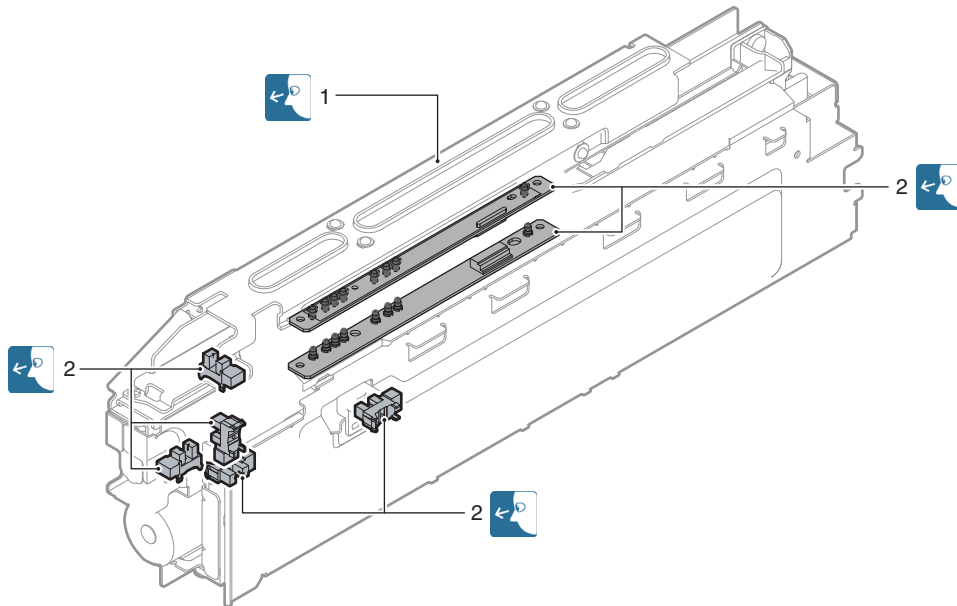

▲/  : Replace    △/  : Adjust    ☆/    : Lubricate

Parts work sequence	Part name	When calling	At the machine cycle	Remark
1	Punch unit	×	×	Replacement reference: Replace the unit at every 1000K.
2	Sensors	×	×	



## (7) Paper pass unit





×/  : Check (Clean, replace, or adjust according to necessity.)    ○/       : Clean

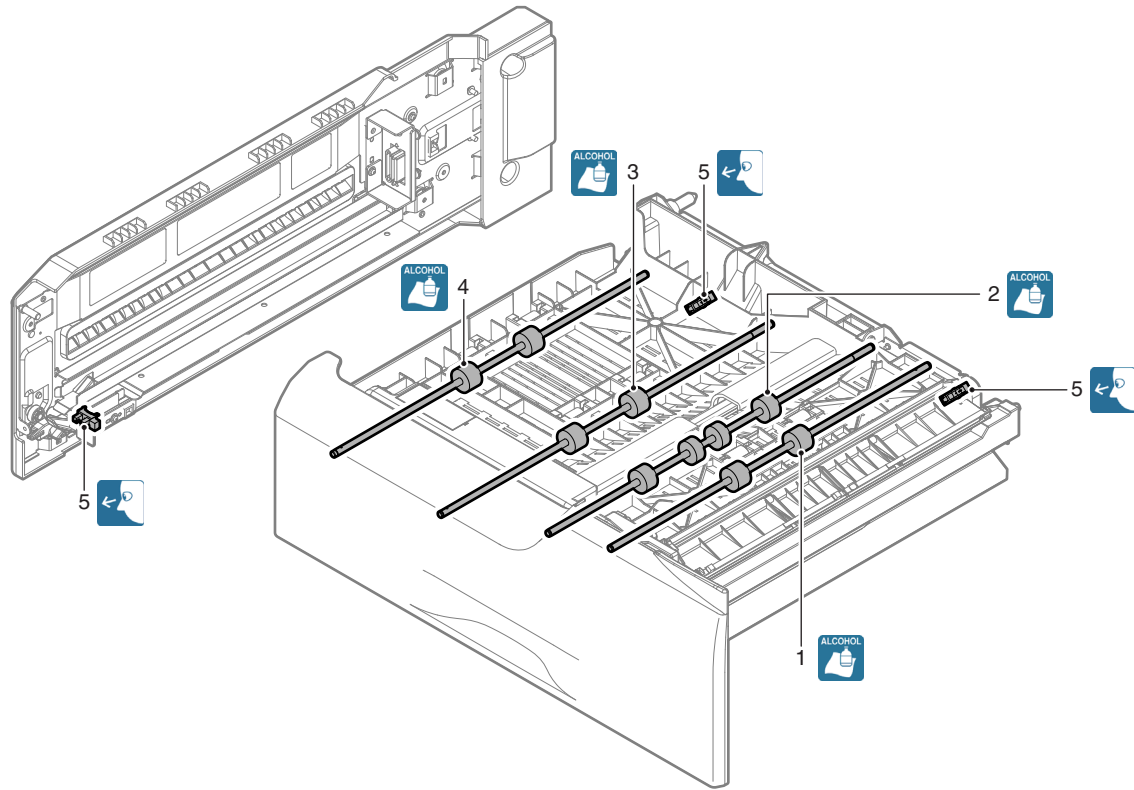

▲/  : Replace    △/  : Adjust    ☆/    : Lubricate

Parts work sequence	Part name	When calling	At the machine cycle	Remark
1	Inlet port roller	○	○	
2	Inlet port rear roller	○	○	
3	Paper exit front roller	○	○	
4	Paper exit roller	○	○	
5	Sensors	×	×	
-	Paper guides	×	○	Clean with alcohol.



## (8) Saddle stitch finisher

×/  : Check (Clean, replace, or adjust according to necessity.)    ○/       : Clean

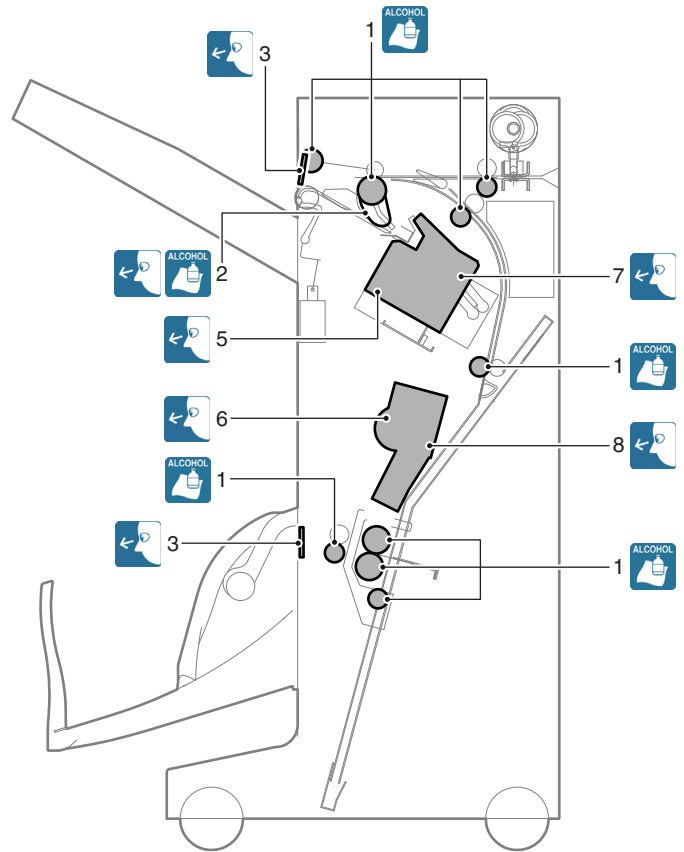
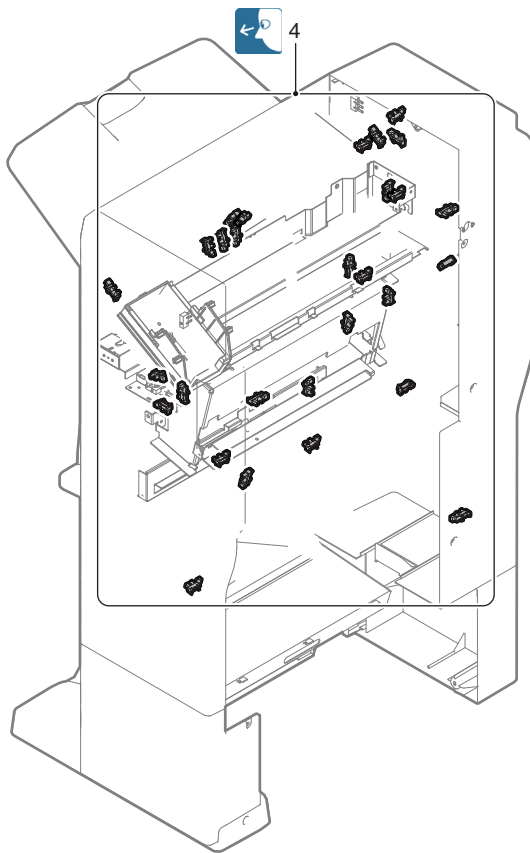

▲/  : Replace    △/  : Adjust    ☆/    : Lubricate

Parts work sequence	Part name	When calling	At the machine cycle	Remark
1	Transport rollers	○	○	
2	Knurling belt	×	○	
3	Discharge brush	×	×	
4	Sensors	×	×	
5	Staple unit	×	×	Replacement reference: Replace the unit at every 200K staple.
6	Staple unit (for saddle)	×	×	Replacement reference: Replace the unit at every 100K staple.
7	Staple unit	×	×	Replacement reference: Replacement is made by the user at every 5,000 pcs.
8	Staple unit (for saddle)	×	×	Replacement reference: Replacement is made by the user at every 2,000 pcs.
-	Gears	×	×	
-	Belts	×	×	
-	Paper guides	×	○	Clean with alcohol.





## (9) Punch unit

×/  : Check (Clean, replace, or adjust according to necessity.)    ○/       : Clean

▲/  : Replace    △/  : Adjust    ☆/    : Lubricate

Parts work sequence	Part name	When calling	At the machine cycle	Remark
1	Punch unit	×	×	Replacement reference: Replace the unit at every 1000K.
2	Sensors	×	×	

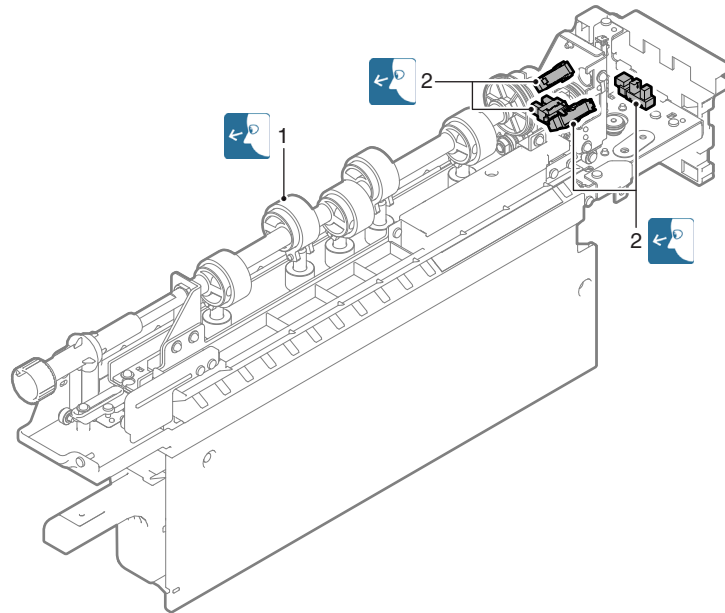

# [9] DISASSEMBLY AND ASSEMBLY

## 1. Disassembly of Units

### A. External view

No.	Name
1	Front cabinet upper
2	Rear upper cabinet
3	Rear cabinet
4	Left cabinet
5	Shield plate
6	Paper exit cover
7	Left cabinet upper
8	Paper exit tray
9	Upper cabinet left
10	Upper cabinet right
11	ROM cover
12	Ozone filter cover

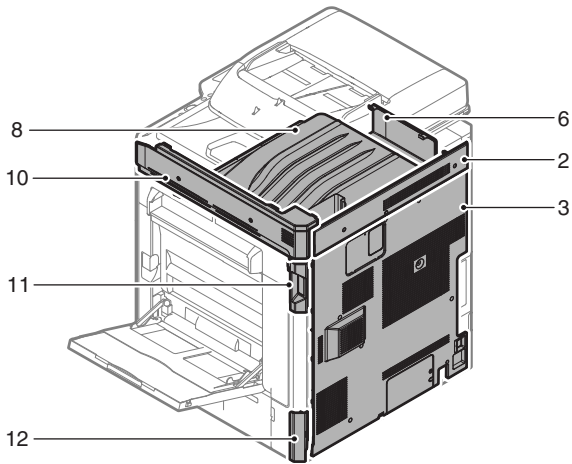
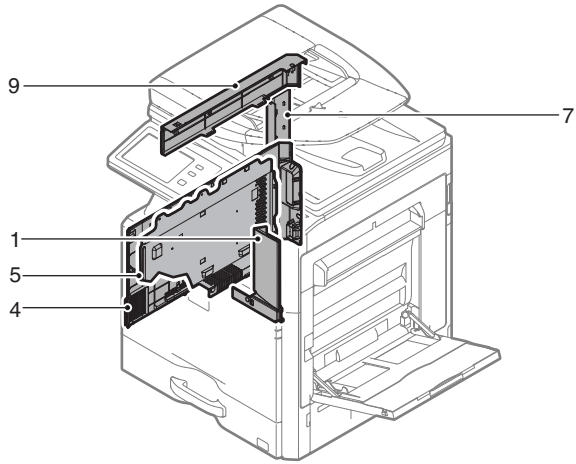

#### (1) Front cabinet upper

- 1) Remove the front cabinet upper.

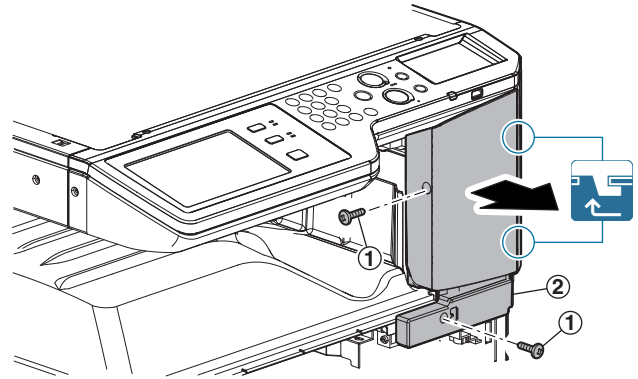

#### (2) Rear upper cabinet

- 1) Remove the rear upper cabinet.

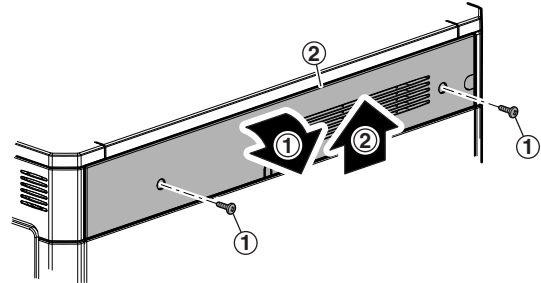

#### (3) Rear cabinet

- 1) Remove the rear cabinet.

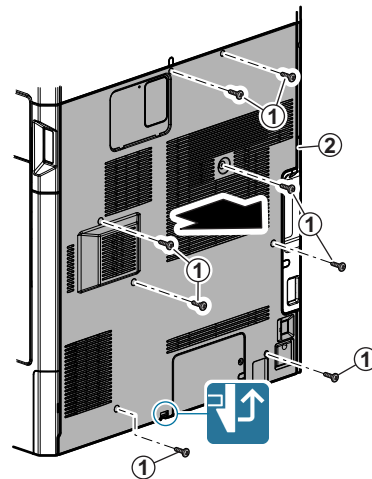

#### (4) Rear cabinet, Shield plate

- 1) Remove the left cabinet.

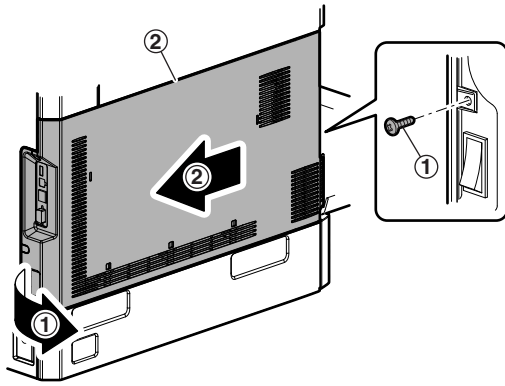

- 2) Remove the shield plate.

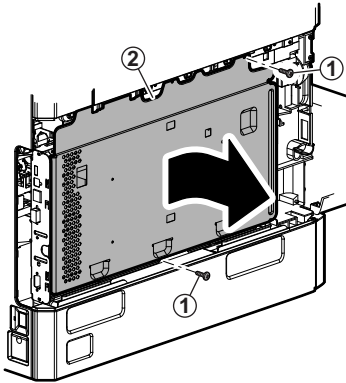

#### (5) Paper exit cover, Left cabinet upper, Paper exit tray

- 1) Remove the front cabinet upper.
- 2) Remove the paper exit cover.

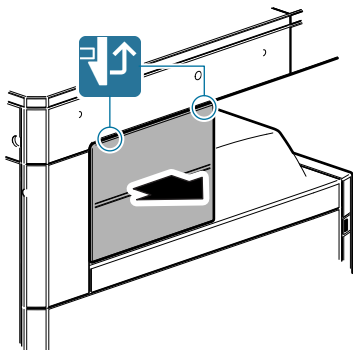

- 3) Remove the left cabinet upper.

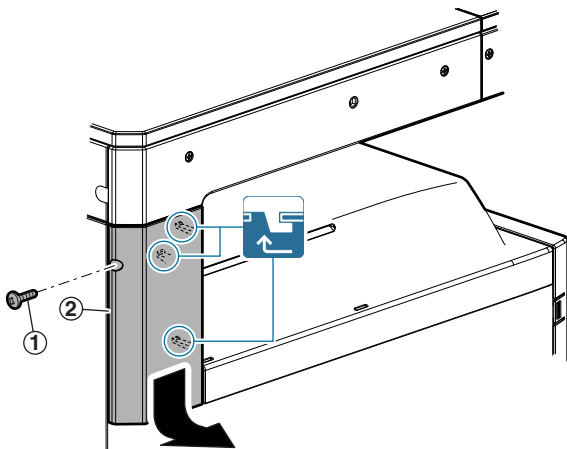

- 4) Remove the paper exit tray.

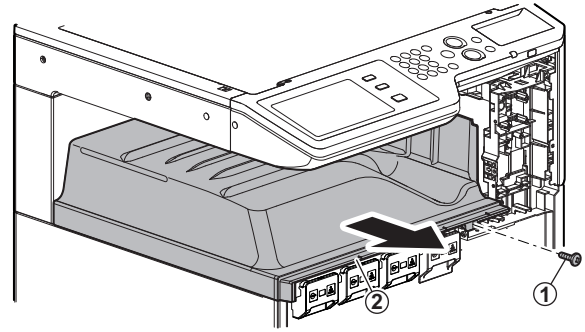

#### (6) Left cabinet lower

- 1) Remove the left cabinet lower.

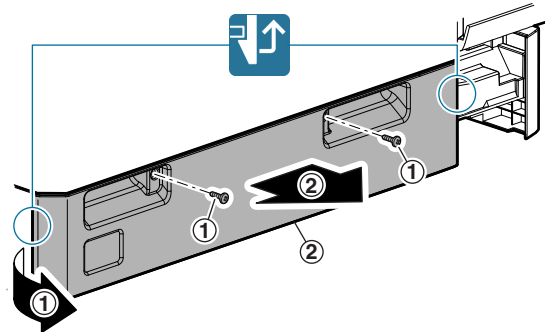

#### (7) Upper cabinet left, Upper cabinet right

- 1) Remove the rear cabinet upper.
- 2) Remove the RSPF unit.
- 3) Remove the table glass and the SPF glass.
- 4) Remove the paper exit cover.
- 5) Remove the upper cabinet left.

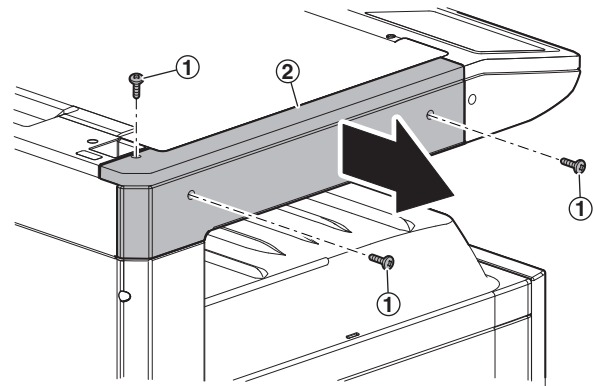

- 6) Remove the upper cabinet right.

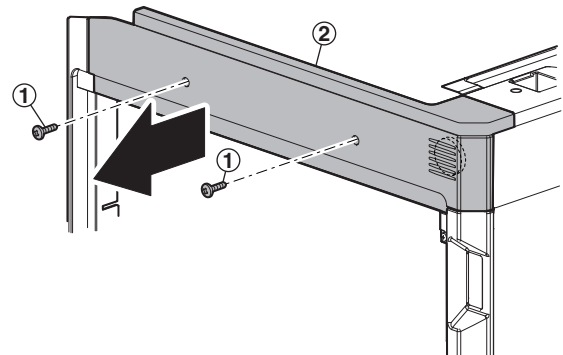

### (8) ROM cover

- 1) Remove the rear cabinet.
- 2) Open the right door, and remove the ROM cover.

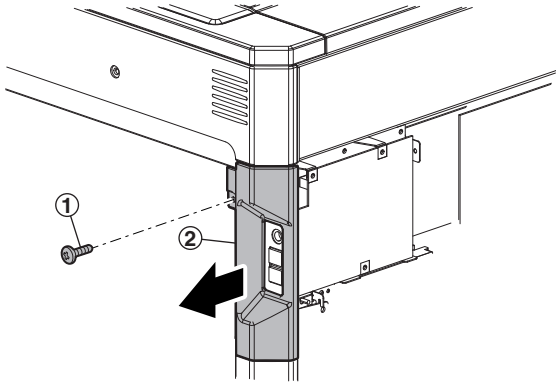

### (9) Ozone filter cover

- 1) Remove the ozone filter cover.

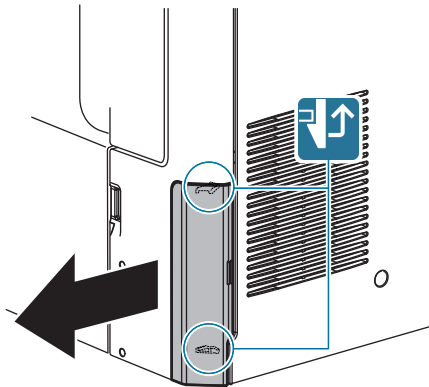

## B. Operation panel section

No.	Name
1	Operation panel unit (18cpm/20cpm/23cpm/31cpm(G) machine)
2	Operation panel unit (26cpm/36cpm/31cpm(A) machine)

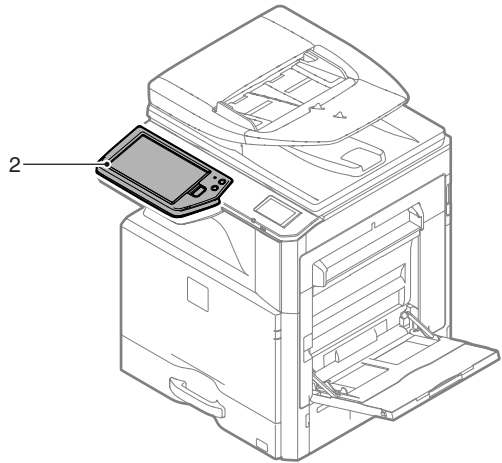
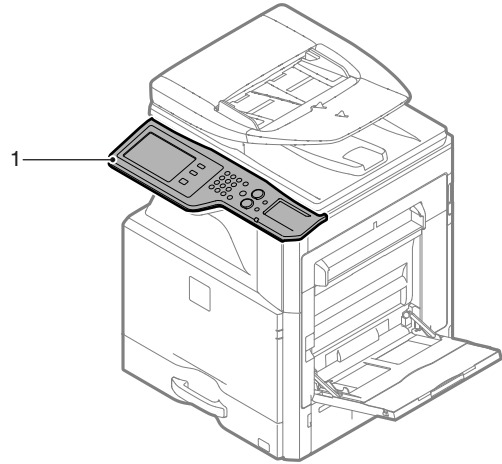

### (1) Operation panel unit (18cpm/20cpm/23cpm/31cpm(G) machine)

- 1) Remove the front cabinet upper.
- 2) Remove the operation panel lower cover.

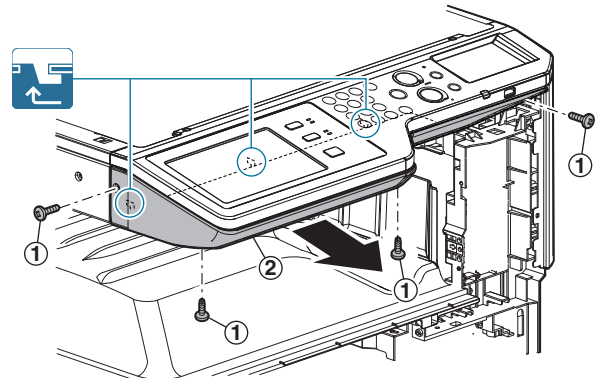

3) Remove the operation panel unit.

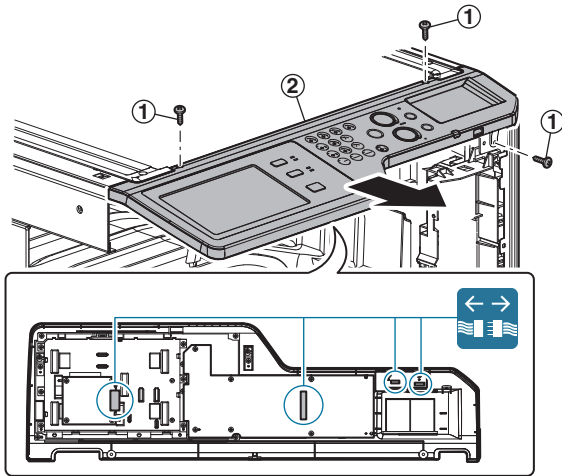

4) Slide the operation panel unit to the left, and put it down. Remove the operation panel cover.

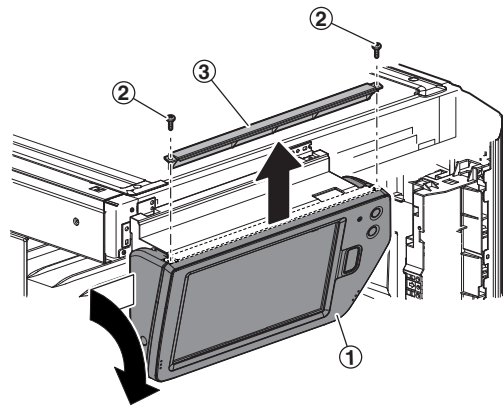

5) Put the operation panel unit up, and remove the operation panel lower cover.

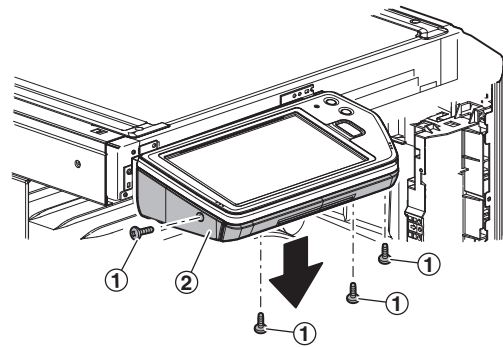

**(2) Operation panel unit  
(26cpm/36cpm/31cpm(A) machine)**

- 1) Remove the front cabinet upper.
- 2) Remove the operation panel cover.

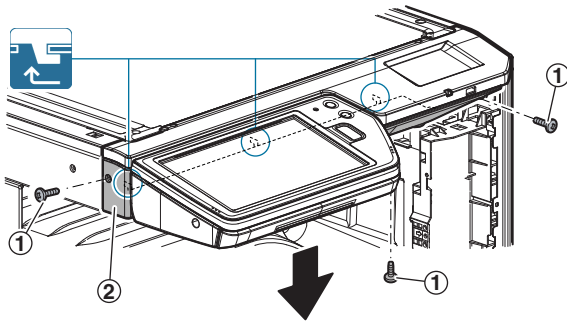

3) Remove the operation panel upper cover.

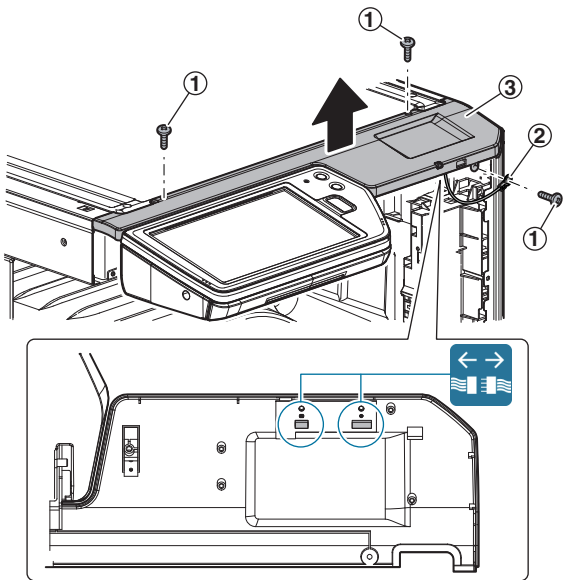

6) Turn over the operation panel unit.

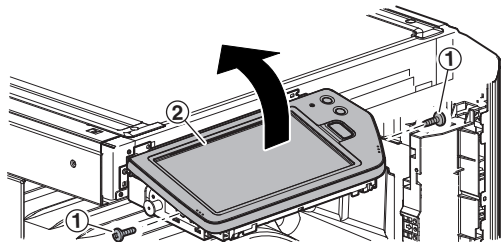

**Important**

When attaching the operation panel unit, insert the Mylar tip into the cover of the operation section.

**Important**

Allow slack around section A of the flat cable.

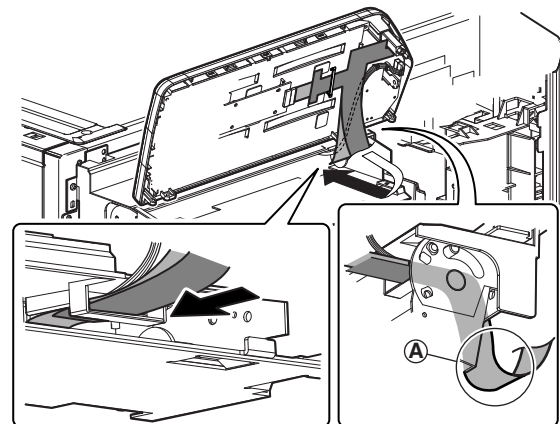

- 7) Remove the clamp. Peel off the Mylar and disconnect the connector.

**Important**

When assembling, put the Mylar on the flat cable and fix them with the clamp.

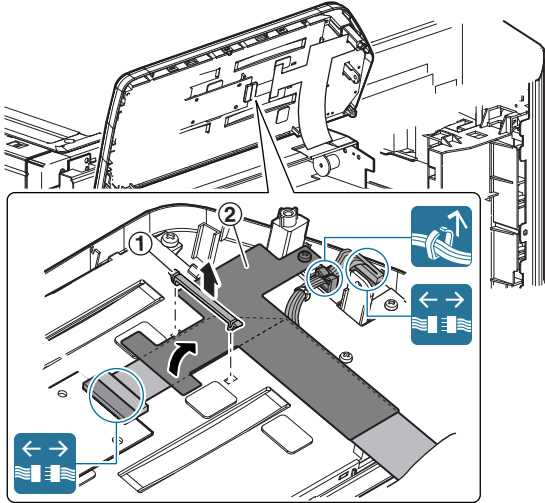

**Important**

Fit the edges of the flat cable and those of section A of the Mylar, and eliminate slack in section B of the flat cable.

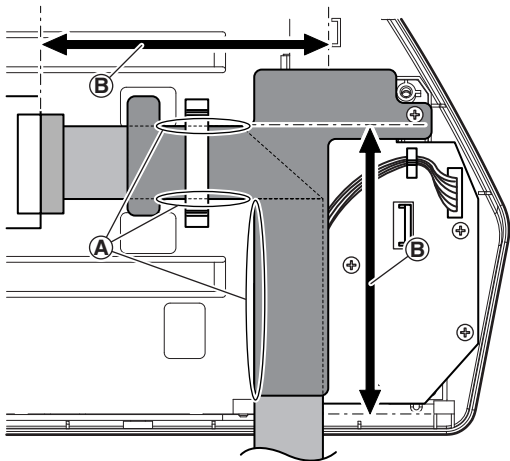

**C. RSPF section**

No.	Name
1	RSPF unit
2	RSPF paper feed tray unit
3	RSPF transport unit

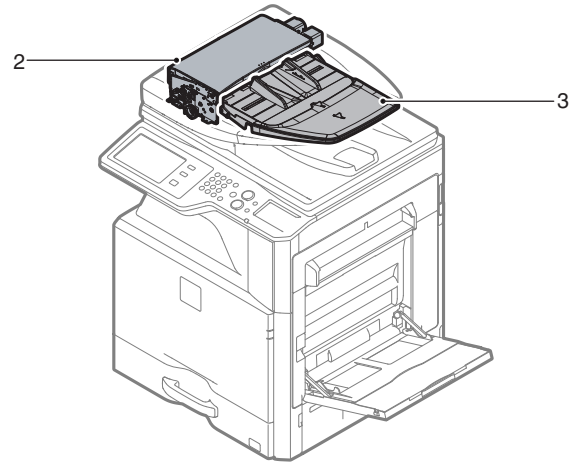
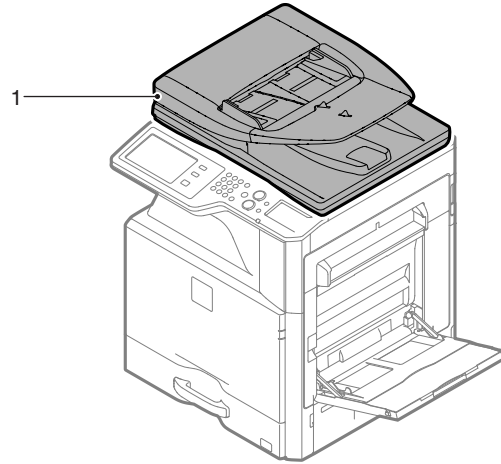

**(1) RSPF unit**

- 1) Remove the rear upper cabinet.
- 2) Disconnect the connector. Remove the harness guide.

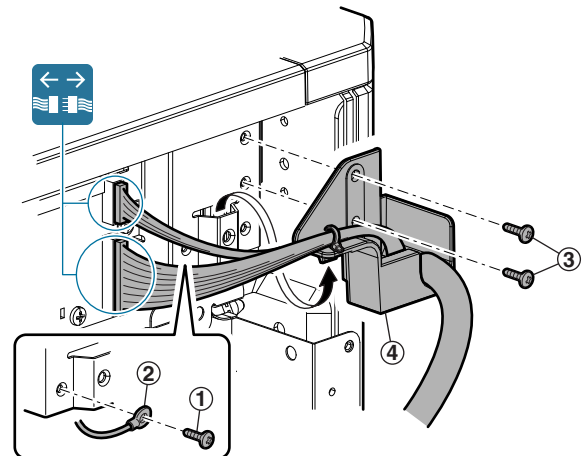

3) Remove the RSPF unit from the machine.

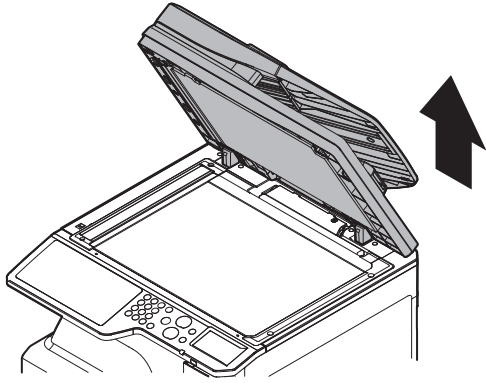

3) Remove the rear cabinet.

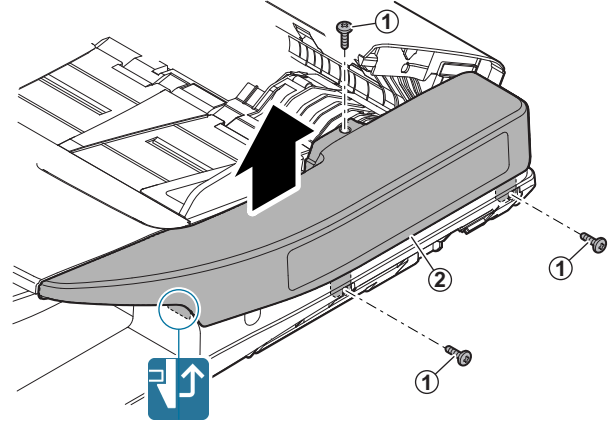

## (2) RSPF paper feed tray unit

1) Turn over the left upper corner of the OC mat.

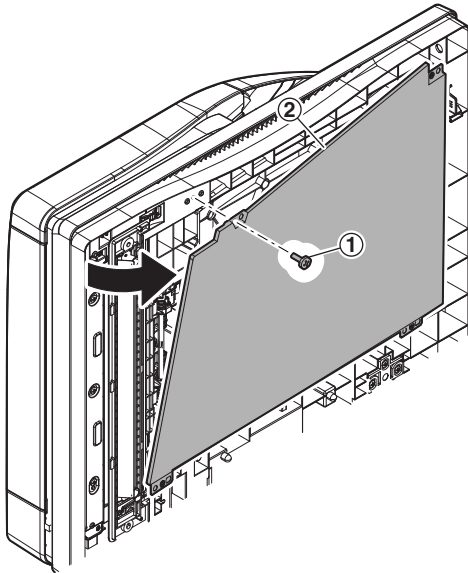

4) Disconnect the connector from the RSPF driver PWB. Remove the holder, and remove the RSPF paper feed tray unit.

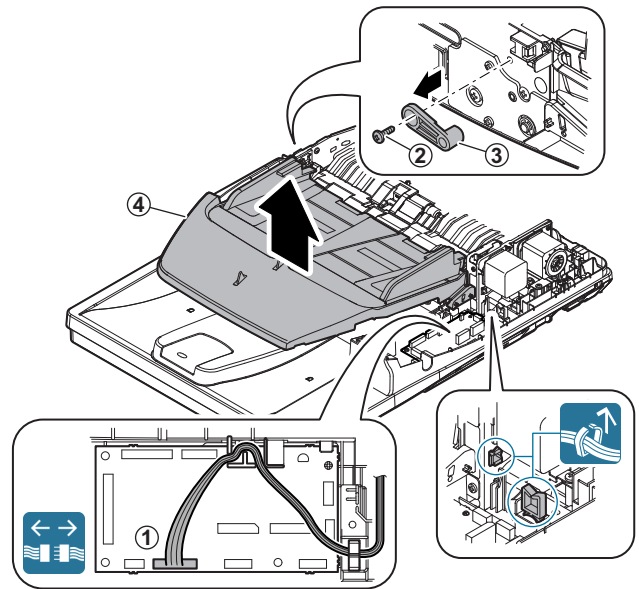

2) Remove the front cabinet.

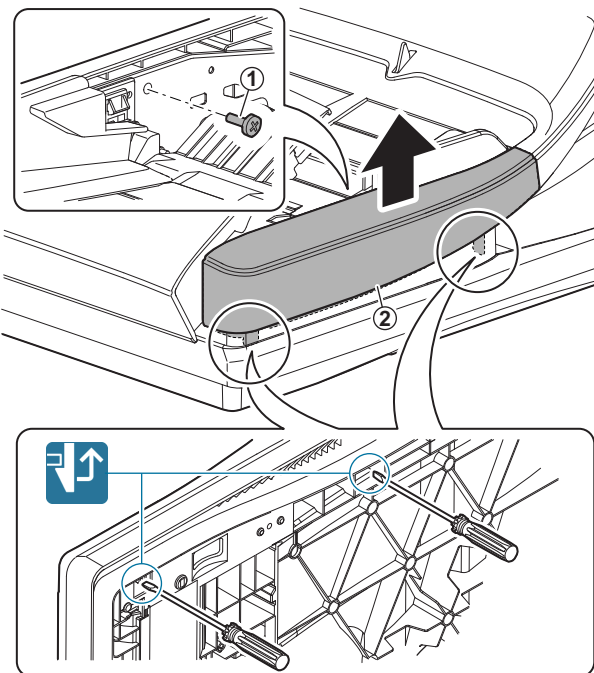

## (3) RSPF transport unit

1) Remove the paper feed tray unit.

2) Remove the earth wire. Disconnect the connector from the RSPF driver PWB.

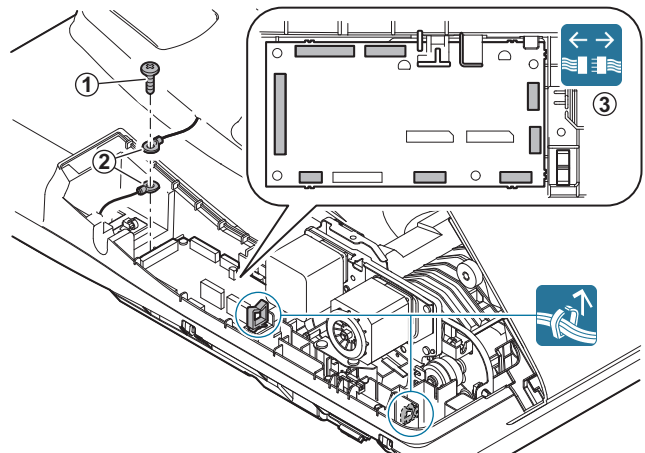

3) Remove the RSPF transport unit.

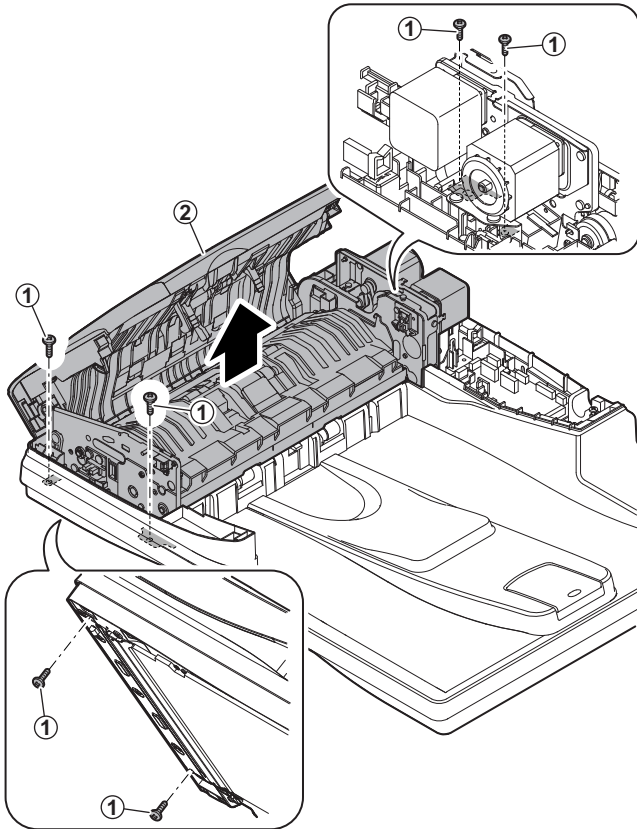

## D. Scanner section

No.	Name
1	Scanner unit

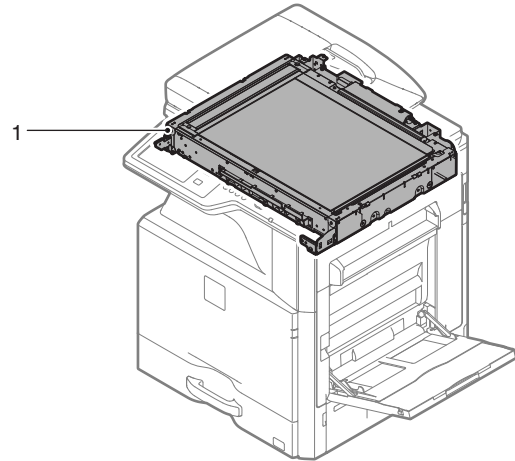

### (1) Scanner unit

- 1) Remove the RSPF unit.
- 2) Remove the operation panel unit.
- 3) Remove the table glass and the SPF glass.
- 4) Remove the upper cabinet left, and the upper cabinet right.
- 5) Remove the scanner unit.

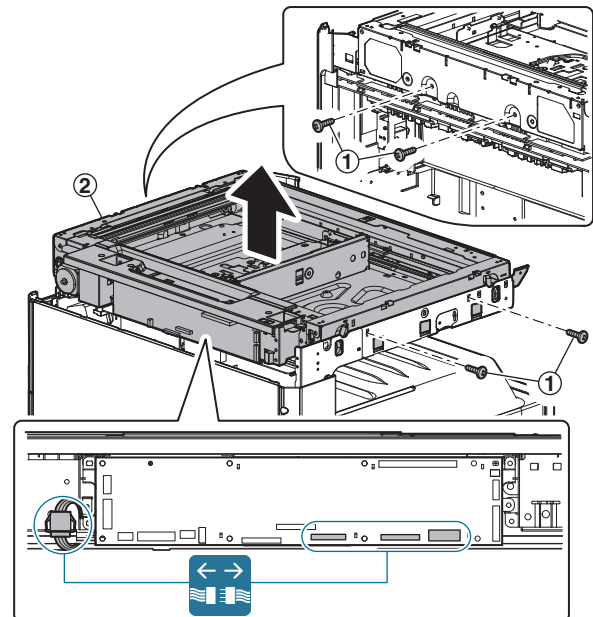



## E. Waste toner collection section

No.	Name
1	Waste toner box

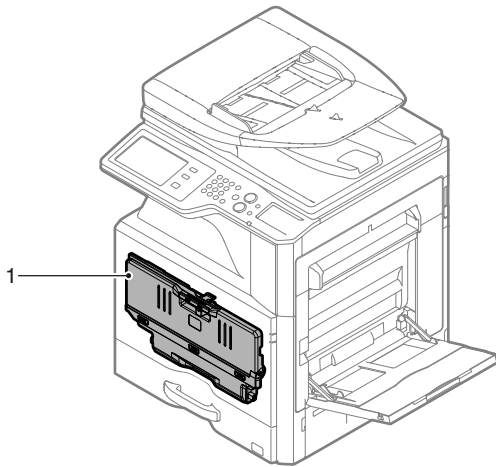

### (1) Waste toner box

- 1) Open the front cabinet. Slide the lock to release it, and remove the waste toner box.

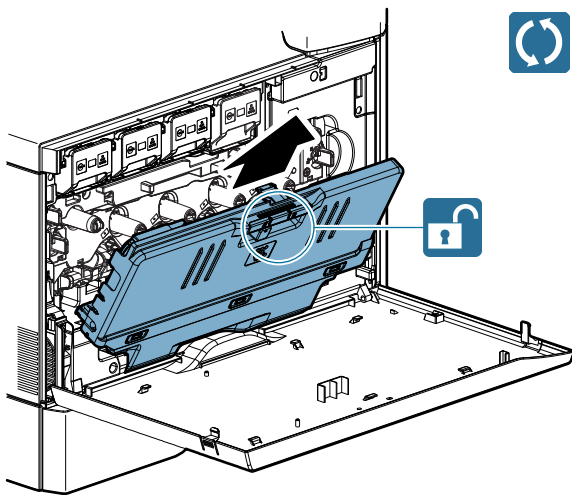

## F. Developing section

No.	Name
1	Developing unit

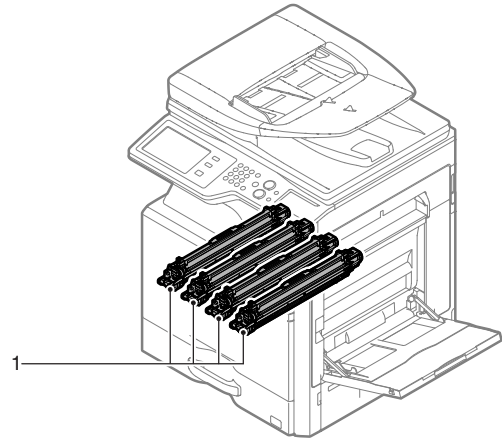

### (1) Developing unit

- 1) Remove the waste toner box.
- 2) Turn the lock to release, and open the drum positioning cover.

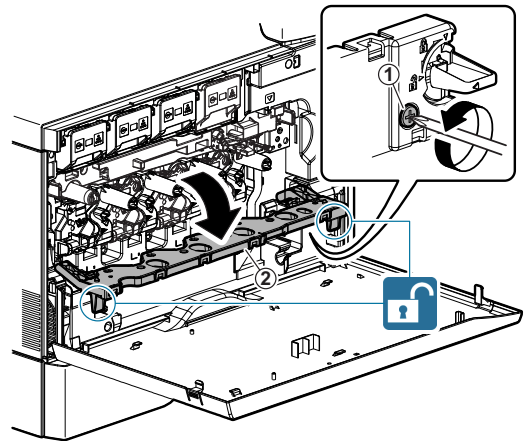

- 3) While pressing the lever, pull out the developing unit to remove.

### Important

When pulling out and pushing in the developing unit, put your hand beneath the unit and slide it horizontally along the guide. At the time, be careful not to touch the developing roller surface.

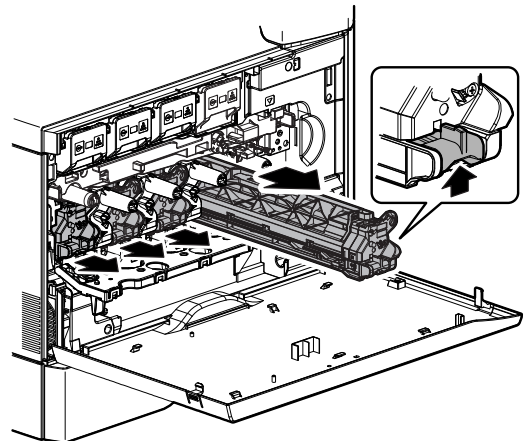

## G. OPC drum section

No.	Name
1	OPC drum unit

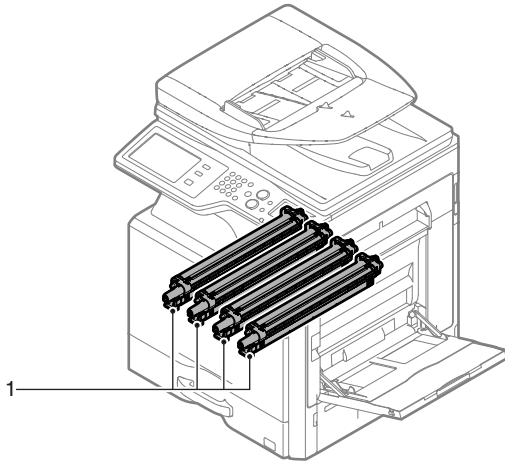

### (1) OPC drum unit

- 1) Remove the waste toner box.
- 2) Remove the developing unit.
- 3) While pressing the lever, pull out the OPC drum to remove.

#### Important

When pulling out and pushing in the OPC drum unit, put your hand beneath the unit and slide it horizontally along the guide on the right side.

At the time, be careful not to touch the OPC drum surface.

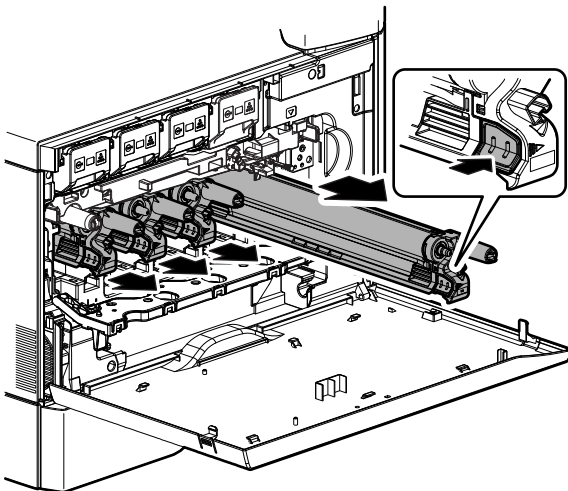

## H. Transfer section

No.	Name
1	Primary transfer unit
2	Primary transfer cleaner unit
3	Secondary transfer unit
4	PTC unit

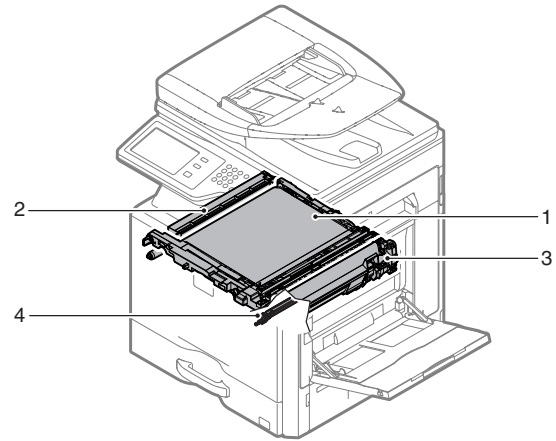

### (1) Primary transfer unit

- 1) Remove the waste toner box.
- 2) Turn the lock to release, and open the drum positioning cover.

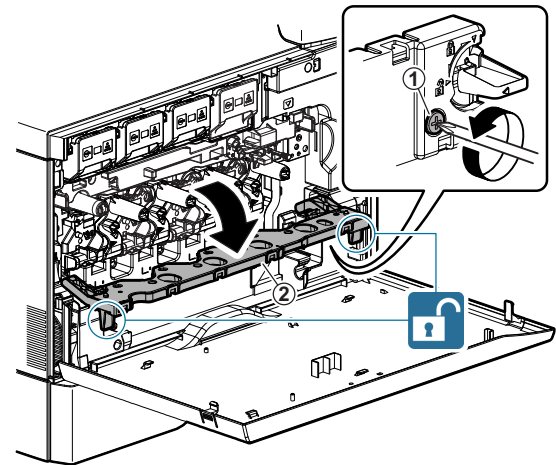

#### Important

Before opening the drum positioning cover, check to confirm that the transfer cam knob is at the free position.

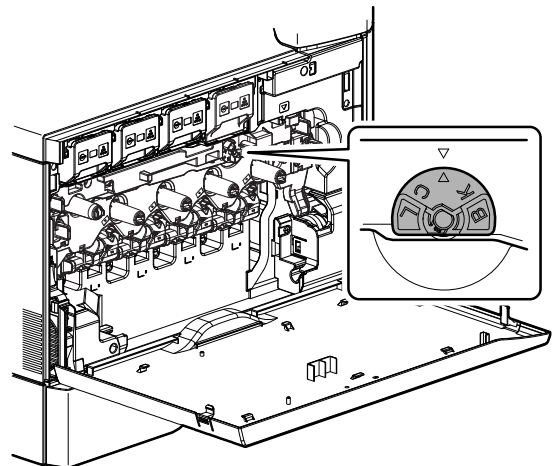



## I. LSU section

No.	Name
1	LSU

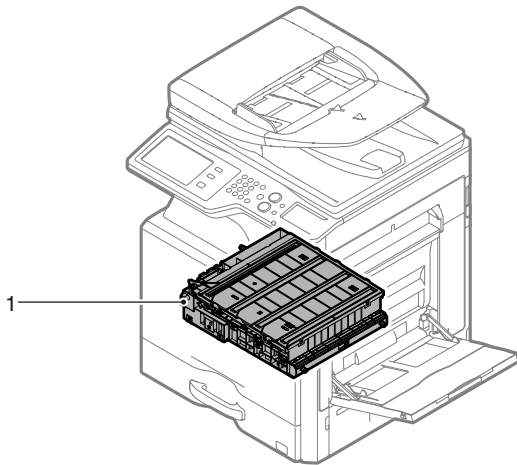

### (1) LSU

- 1) Remove the left cabinet, and the shield plate.
- 2) Remove the MFP control PWB unit.

**Important**

Since the MFP control PWB and the LSU mother PWB are connected together (board to board), use care when removing and attaching them.

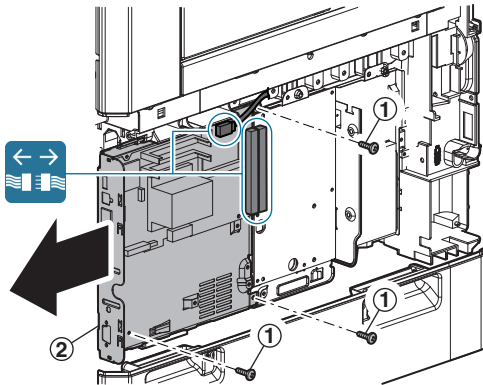

- 3) Remove the LSU mother PWB unit, and the HDD unit.

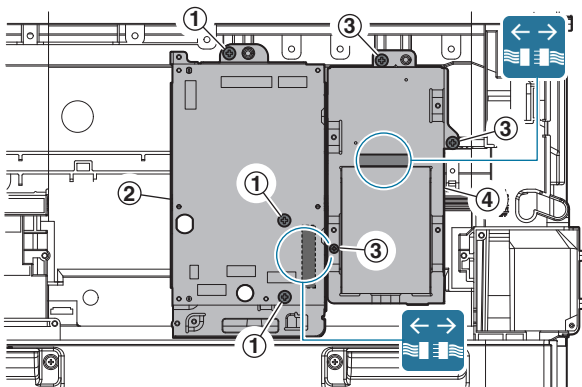

- 4) Remove the waste toner box.
- 5) Lift the LSU mother PWB unit, and remove the LSU.

**Important**

Do not touch the LSU PWB and the upper cover glass section.

**Important**

Put the LSU on a flat surface. (Do not turn it over.)

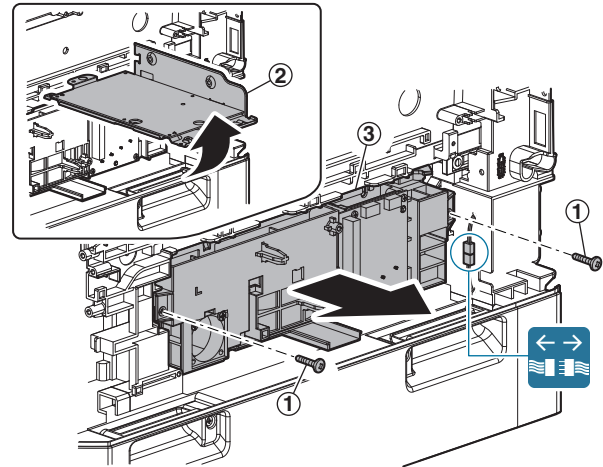

## J. Manual paper feed section

No.	Name
1	Manual paper feed tray
2	Manual paper feed unit

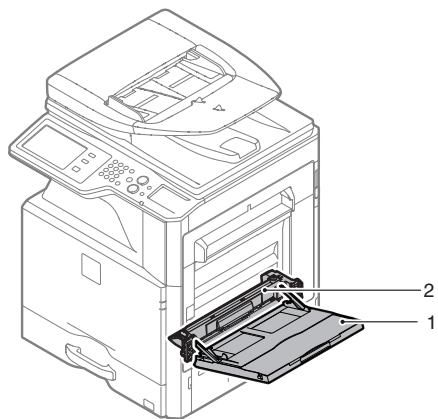

### (1) Manual paper feed tray

#### a. 18cpm/20cpm/23cpm/26cpm/31cpm machine

- 1) Open the right door, and remove the cover.

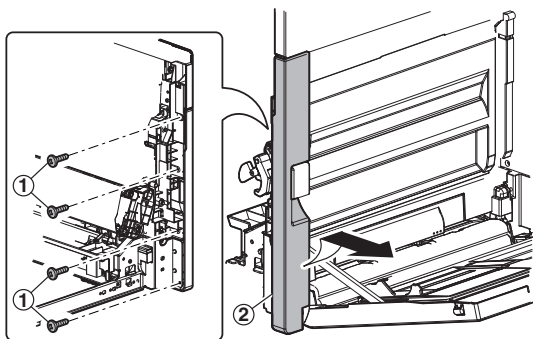

- 2) Remove the connector cover.

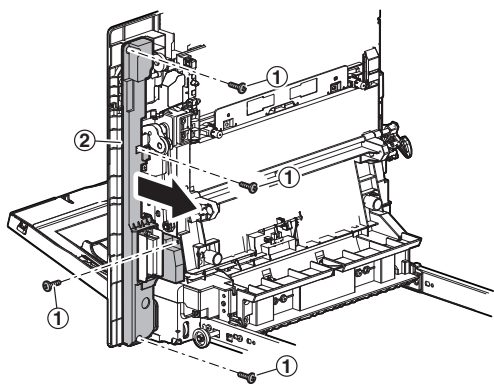

- 3) Remove the cover.

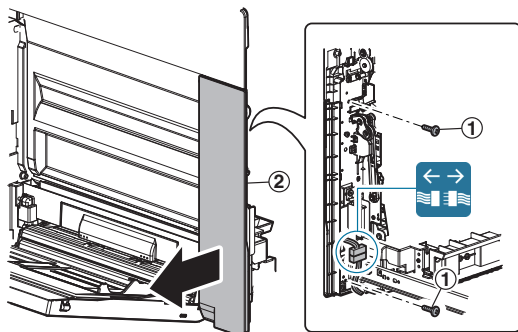

- 4) Remove the shaft.

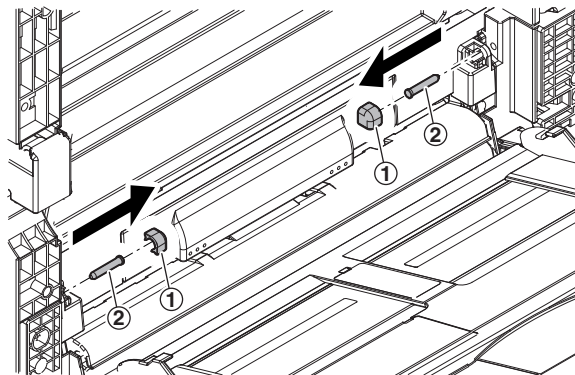

- 5) Slide the tray and remove the arm.

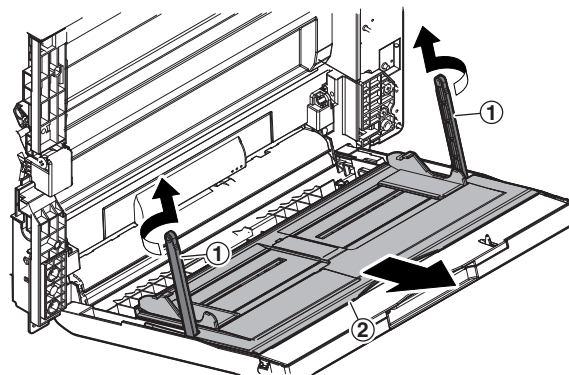

- 6) Remove the cover, and remove the manual paper feed tray.

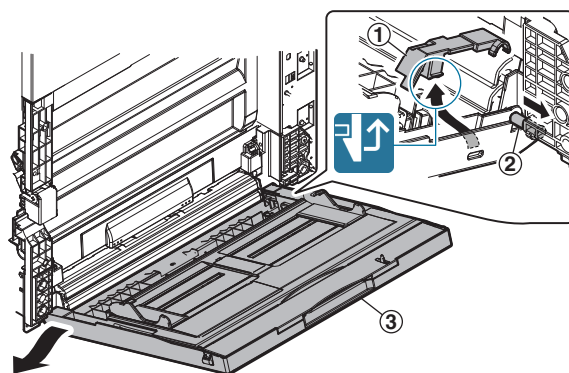

#### b. 36cpm machine

- 1) Open the right door, and remove the cover.

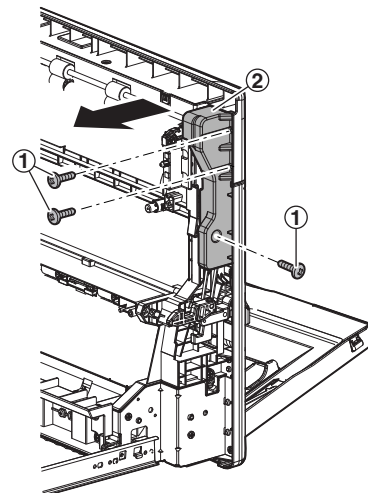

2) Remove the cover.

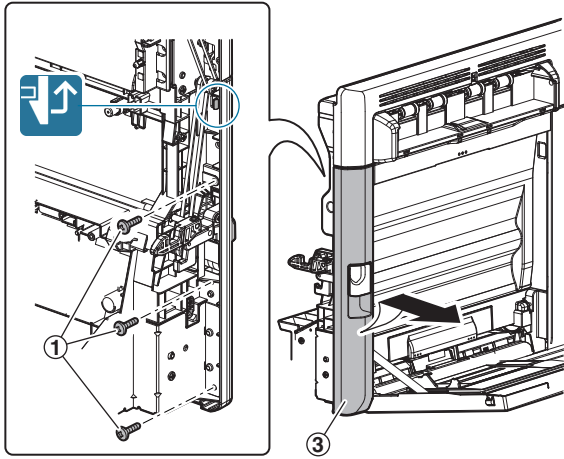

3) Remove the cover.

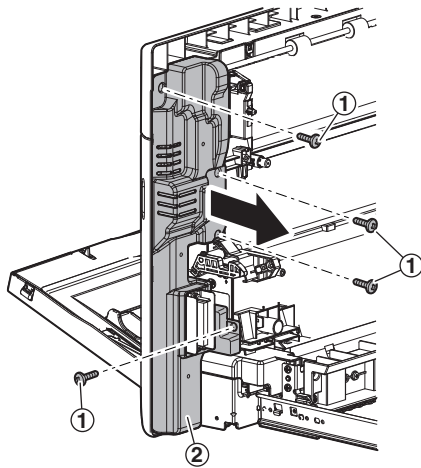

4) Remove the cover.

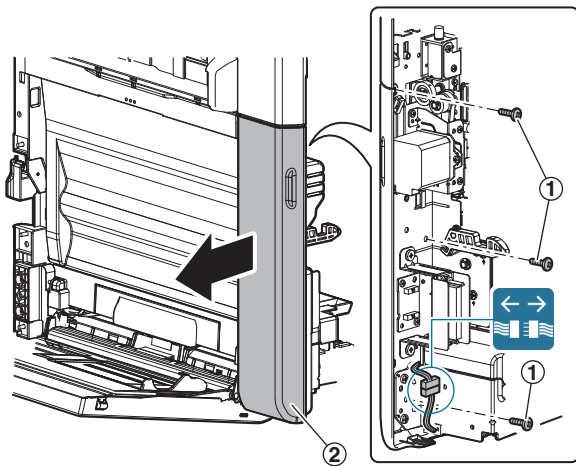

5) Remove the shaft.

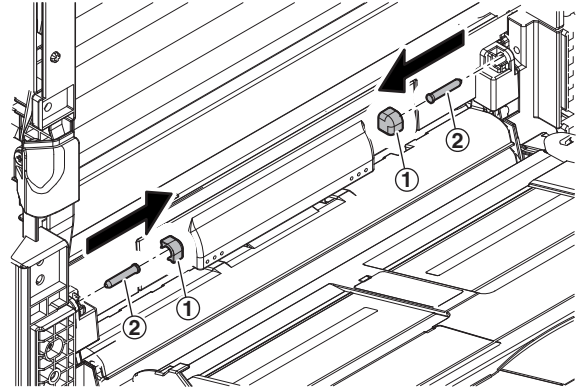

6) Slide the tray and remove the arm.

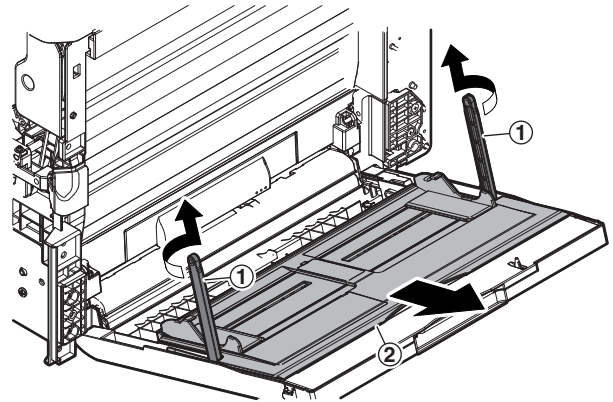

7) Remove the cover, and remove the manual paper feed tray.

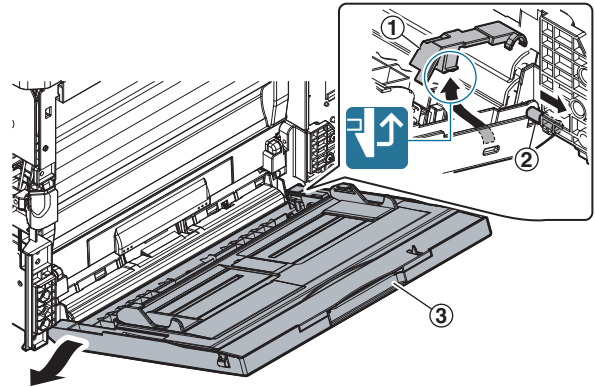

**(2) Manual paper feed unit**

- 1) Remove the manual paper feed tray.
- 2) Remove the manual paper feed unit.

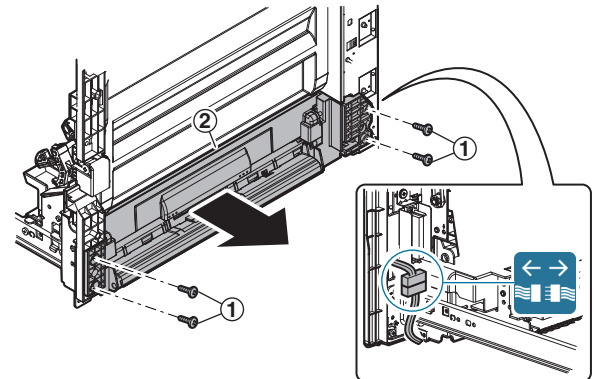

## K. Tray paper feed section

No.	Name
1	Paper feed tray
2	Tray paper feed unit

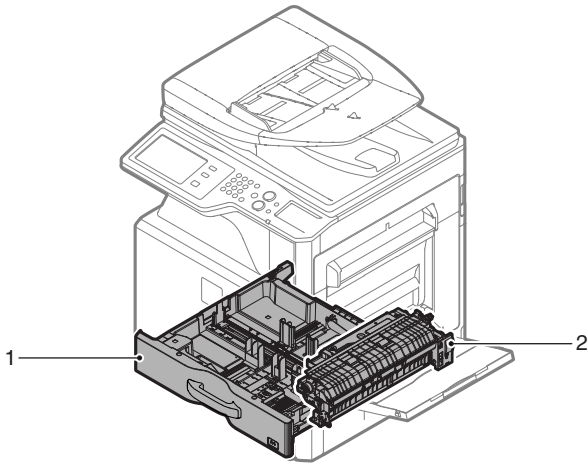

### (1) Paper feed tray

- 1) Pull out the paper feed tray, and lift and remove it.

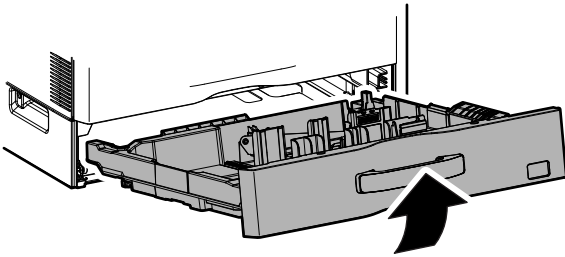

### (2) Tray paper feed unit

- 1) Remove the paper feed tray.
- 2) Remove the right door lower.

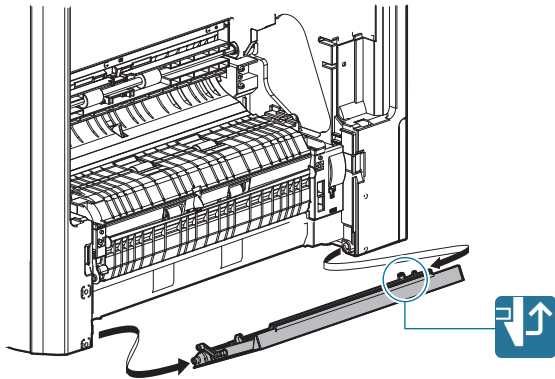

- 3) Remove the paper guide.

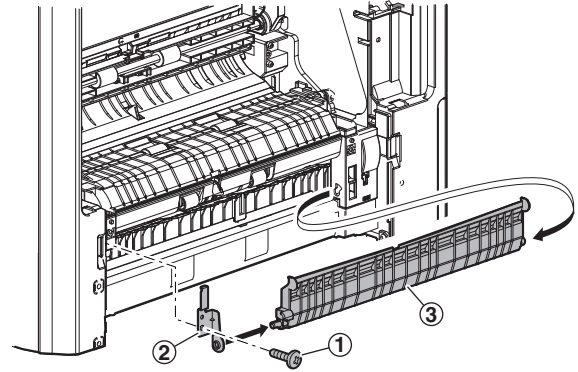

- 4) Remove the tray paper feed unit.

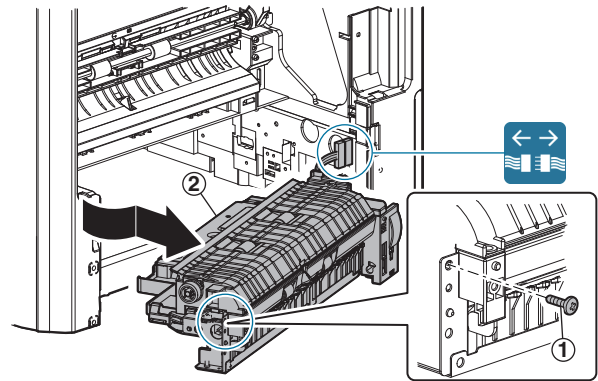

## L. Paper transport/Paper exit/ADU section

No.	Name
1	Paper dust removing unit
2	PS unit
3	Right door unit
4	Fusing rear unit
5	Paper exit unit

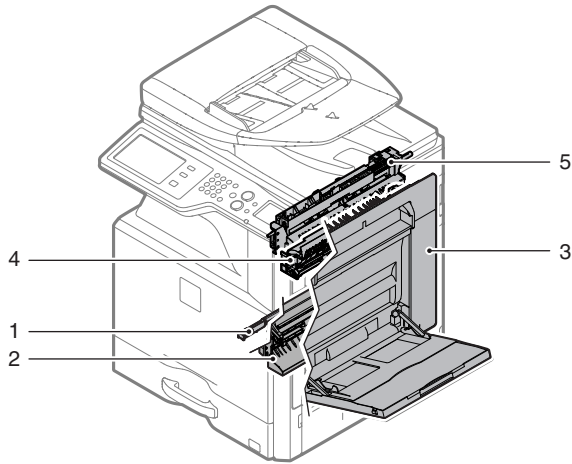

### (1) Paper dust removing unit

- 1) Remove the waste toner box.
- 2) Remove the paper dust cleaner unit.

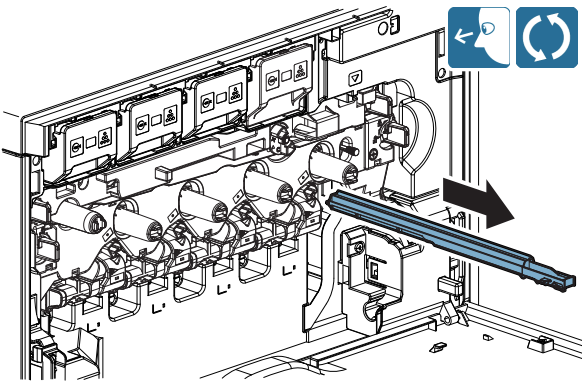

### (2) PS unit

- 1) Remove the waste toner box.
- 2) Remove the paper dust cleaner unit.
- 3) Remove the paper feed tray.
- 4) Remove the tray paper feed unit.
- 5) Remove the PS unit.

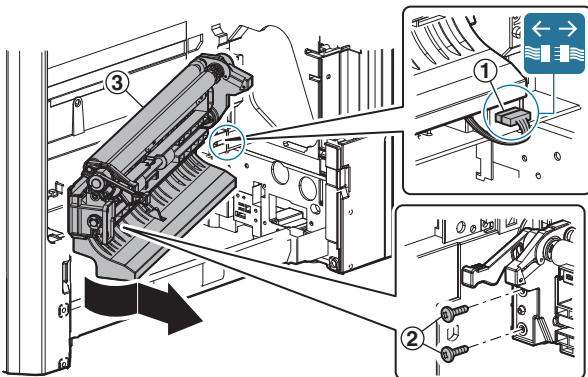

### (3) Right door unit

- 1) Open the right door. Remove the gear, and remove the right door.

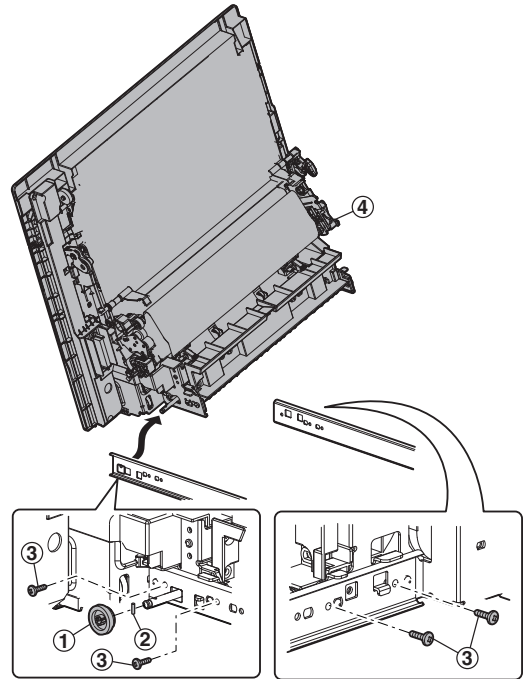

### (4) Fusing rear unit

- 1) Remove the fusing unit.
- 2) Remove the fusing rear unit.

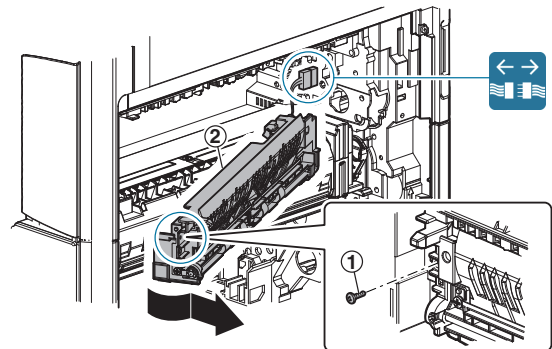

### (5) Paper exit unit

- 1) Remove the front cabinet upper.
- 2) Remove the paper exit tray.
- 3) Remove the paper exit unit.

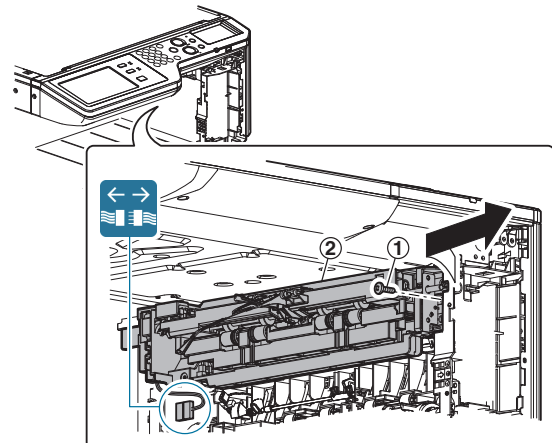



**Important**

When connecting the paper exit unit connector, rotate the harness one turn clockwise as shown in the figure below so that the harness faces toward the arrow A, and connect the connector.

This procedure is necessary for preventing the paper exit sensor from disconnecting by contact with the harness.

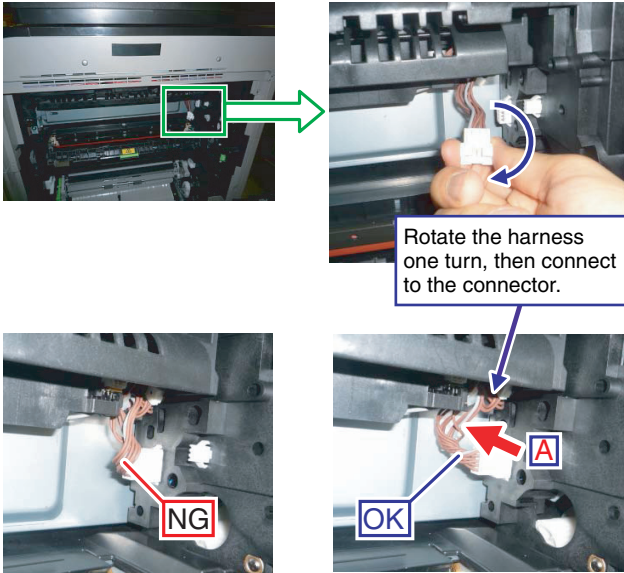

**M. Drive section**

No.	Name
1	Main drive unit
2	Transport drive unit
3	Fusing drive unit
4	Paper exit drive unit

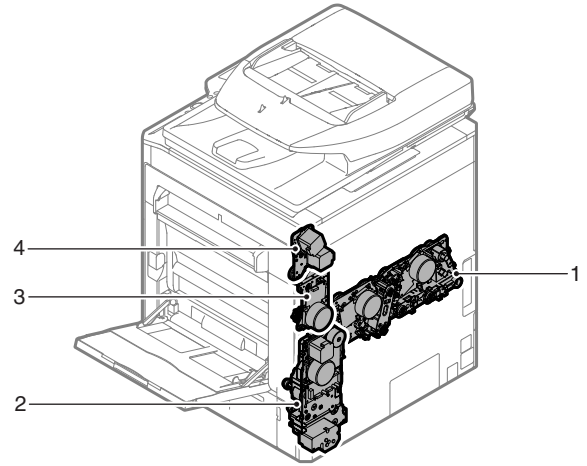

**(1) Main drive unit**

**a. 18cpm/20cpm/23cpm/26cpm/31cpm machine**

- 1) Remove the waste toner box.
- 2) Remove the developing unit.
- 3) Remove the OPC drum unit.
- 4) Remove the primary transfer unit.
- 5) Remove the rear cabinet.
- 6) Remove the main drive unit.

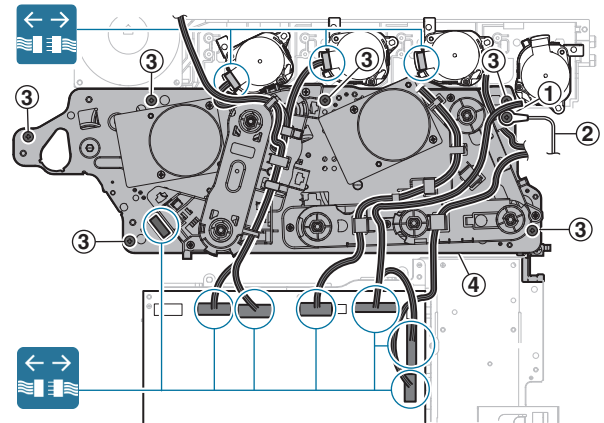

**Important**

When the drive section is disassembled, apply screw lock to the following sections:

**Front side**

Apply screw lock (0.1g: about two rice grains) between the bearing and the drive frame. (4 positions)

**Important**

Be careful not to apply screw lock between the bearing and each DV drive shaft.

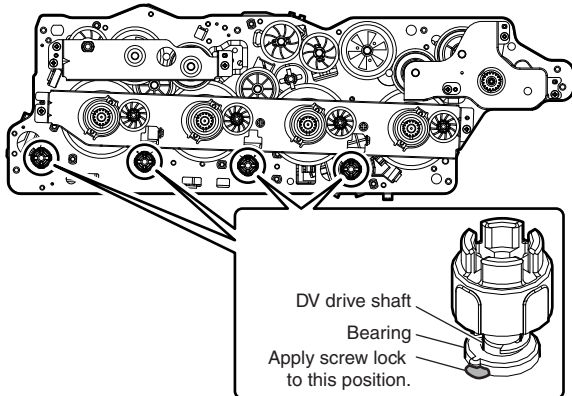

**Rear side**

Apply screw lock (0.04g: about one rice grain). (6 positions)

**Important**

Be careful not to apply screw lock to the head of the screw.

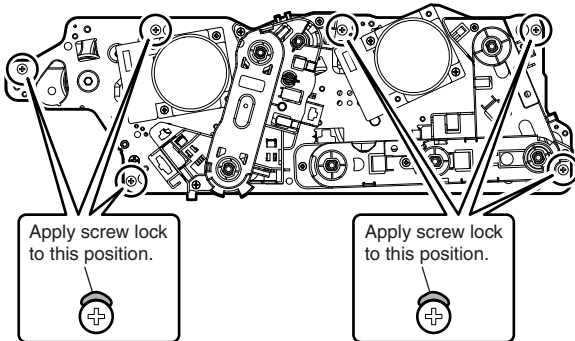

**b. 36cpm machine**

- 1) Remove the waste toner box.
- 2) Remove the developing unit.
- 3) Remove the OPC drum unit.
- 4) Remove the primary transfer unit.
- 5) Remove the rear cabinet.
- 6) Remove the belt drive unit.

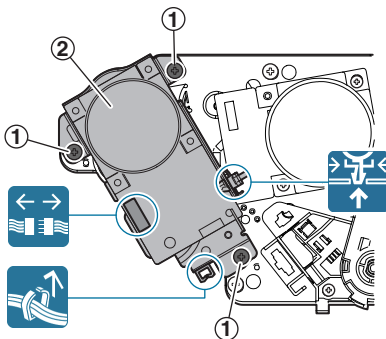

- 7) Remove the main drive unit.

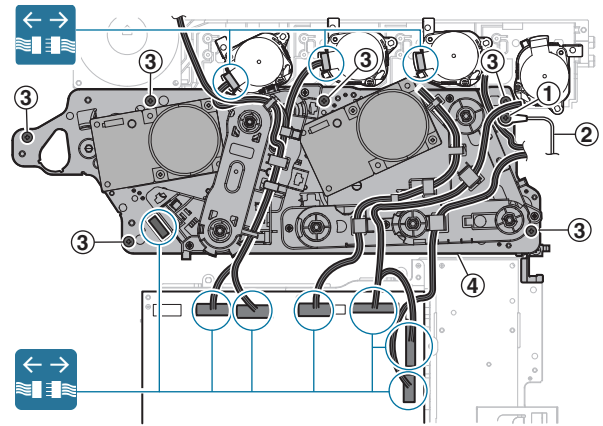

**Important**

When the drive section is disassembled, apply screw lock to the following sections:

**Front side**

Apply screw lock (0.1g: about two rice grains) between the bearing and the drive frame. (4 positions)

**Important**

Be careful not to apply screw lock between the bearing and each DV drive shaft.

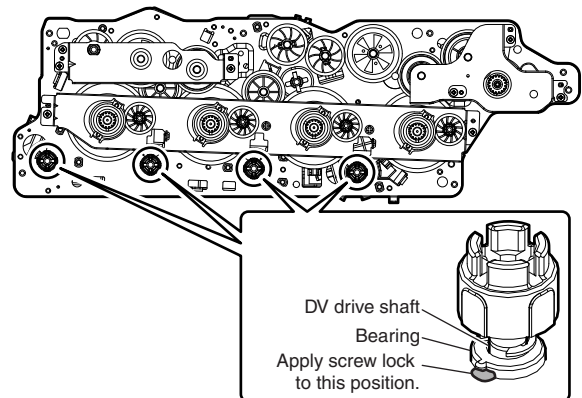

**Rear side**

Apply screw lock (0.04g: about one rice grain). (6 positions)

**Important**

Be careful not to apply screw lock to the head of the screw.

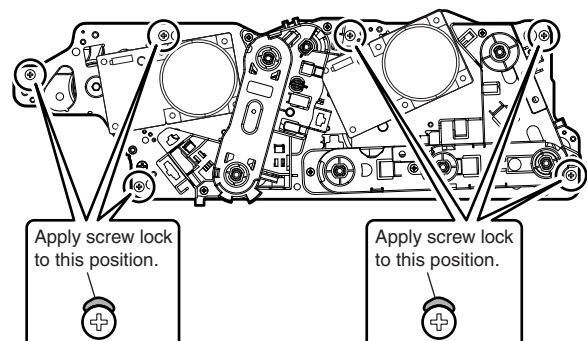

## (2) Transport drive unit

- 1) Remove the rear cabinet.
- 2) Open the right door.
- 3) Remove the ozone filter cover.
- 4) Remove the duct.

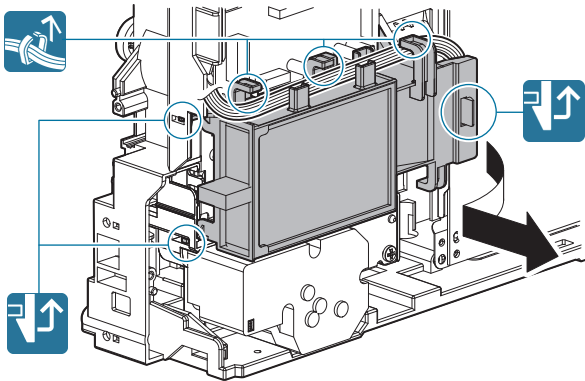

- 5) Remove the transport drive unit.  
**18cpm/20cpm machine**

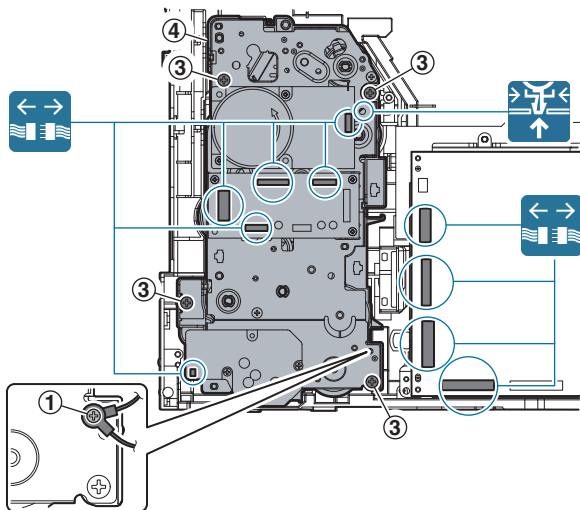

### 23cpm/26cpm/31cpm/36cpm machine

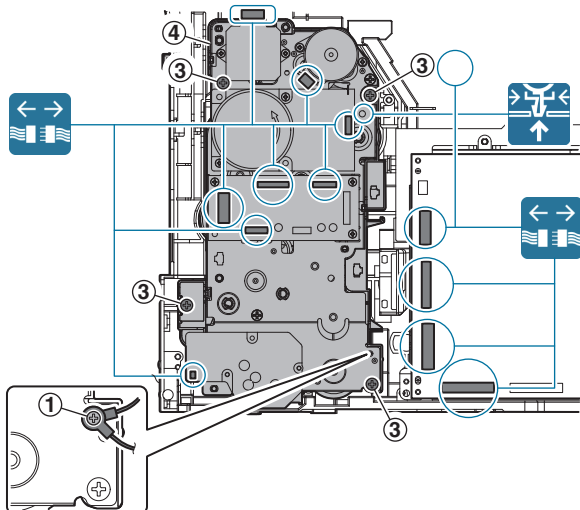

### Important

When the drive section is disassembled, apply screw lock to the following sections:

#### Front side

Apply screw lock (0.1g: about two rice grains) between the bearing and the transport drive frame. (4 positions)

### Important

Be careful not to apply screw lock between the bearing and the drive shaft.

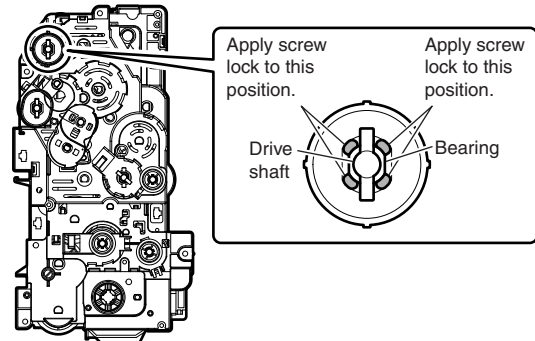

#### Rear side

Apply screw lock (0.1g: about two rice grains) between the bearing and the transport drive frame. (2 positions)

### Important

Be careful not to apply screw lock between the bearing and the drive shaft.

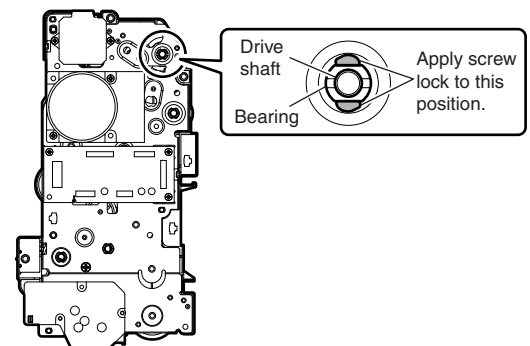

## (3) Fusing drive unit

- 1) Remove the rear cabinet upper.
- 2) Remove the rear cabinet.
- 3) Remove the ROM cover.
- 4) Remove the FAX unit.
- 5) Remove the fusing drive unit.

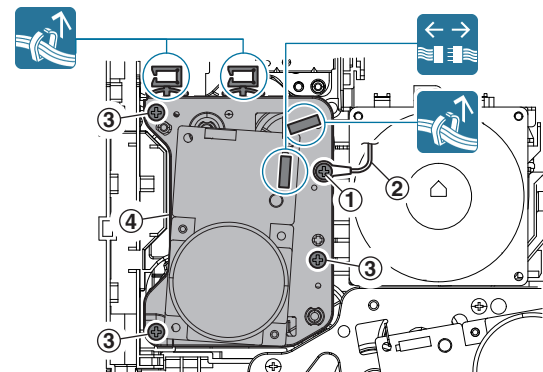

#### (4) Paper exit drive unit

- 1) Remove the rear cabinet upper.
- 2) Remove the rear cabinet.
- 3) Remove the ROM cover.
- 4) Remove the FAX unit.
- 5) Remove the paper exit drive unit.

##### 18cpm/20cpm machine

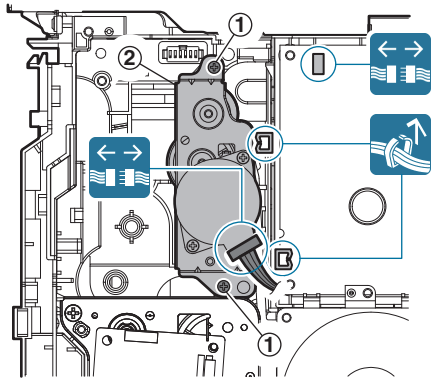

##### 23cpm/26cpm/31cpm machine

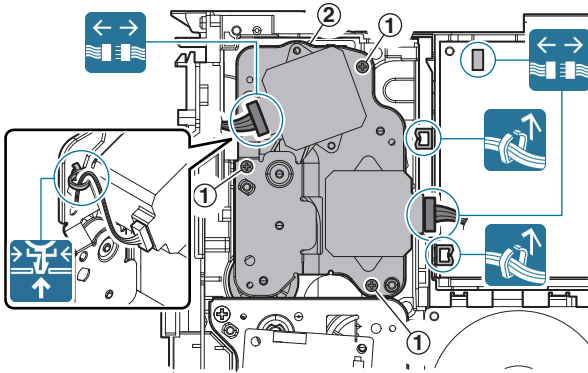

##### 36cpm machine

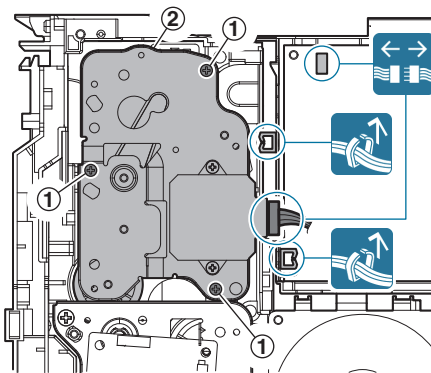

## N. Fusing section

No.	Name
1	Fusing unit

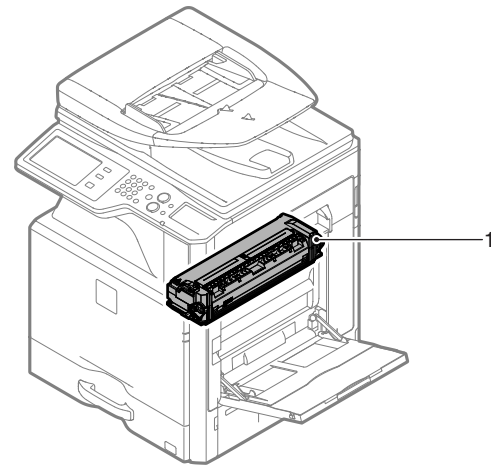

#### (1) Fusing unit

- 1) Open the right door. Release lock, and remove the fusing unit.

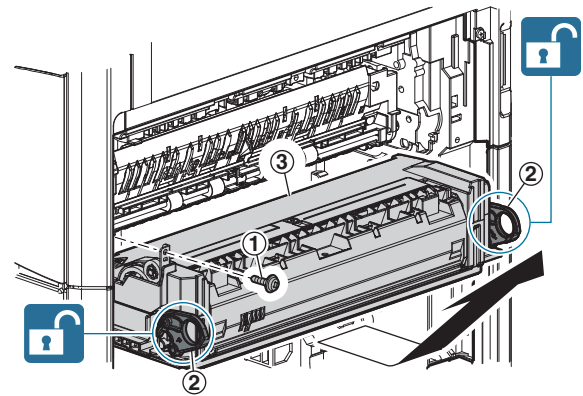

##### 18cpm/20cpm/23cpm/26cpm/31cpm machine

#### Important

When carrying the fusing unit, be sure to hold the both levers on the F and R sides of the fusing unit. If only one lever is held to carry the unit, it may be broken.

##### 36cpm machine

#### Important

When carrying the fusing unit, do not hold the both levers on the F and R sides of the fusing unit.

## O. Toner supply section

No.	Name
1	Toner cartridge

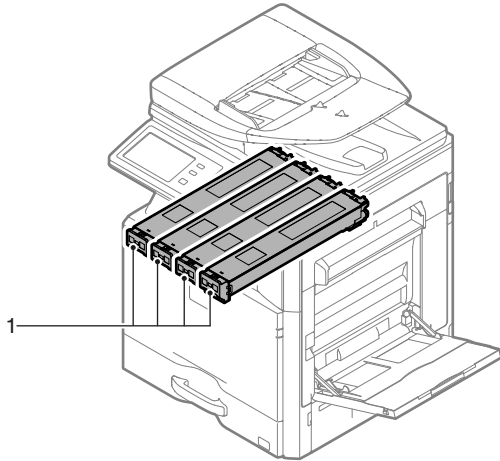

### (1) Toner cartridge

- 1) Open the front cabinet, and remove the toner cartridge.

**Important**

Do not install a toner cartridge of a different color. Be sure to install a toner cartridge of the same color.

**Important**

When installing, do not insert with great force. When inserting, put your hand on it to the end until it locks securely.

**Important**

When the machine is moved with the developing unit removed, be sure to remove the toner cartridge. (If not, toner may clog.)

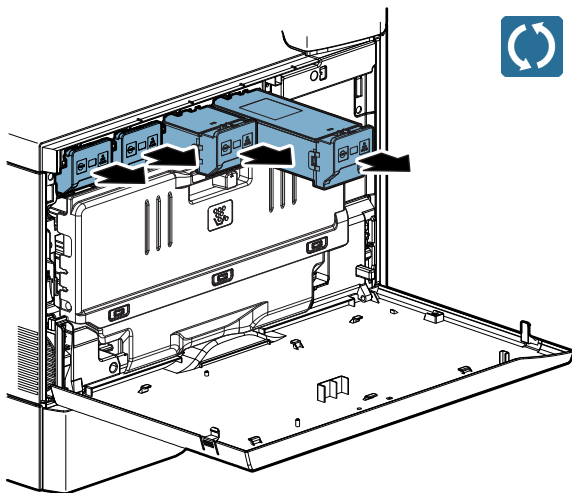

## P. PWB section

No.	Name
1	SCU PWB
2	DC POWER PWB
3	High voltage PWB (TC PWB)
4	HL control PWB
5	PCU PWB
6	High voltage PWB (MC/DV PWB)
7	AC POWER PWB
8	MFP control PWB
9	LSU mother PWB

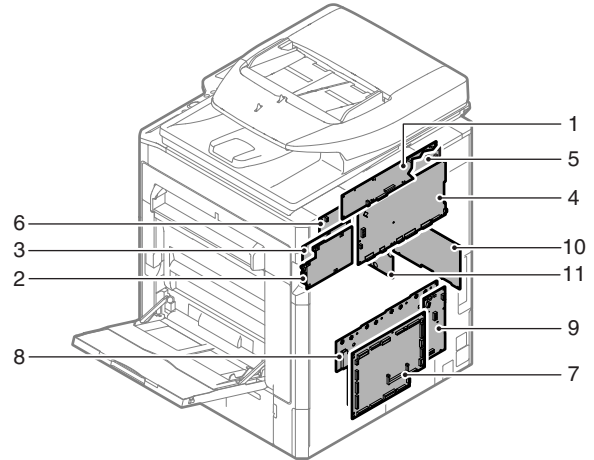

### (1) SCU PWB

- 1) Remove the rear cabinet upper.
- 2) Remove the SCU PWB.

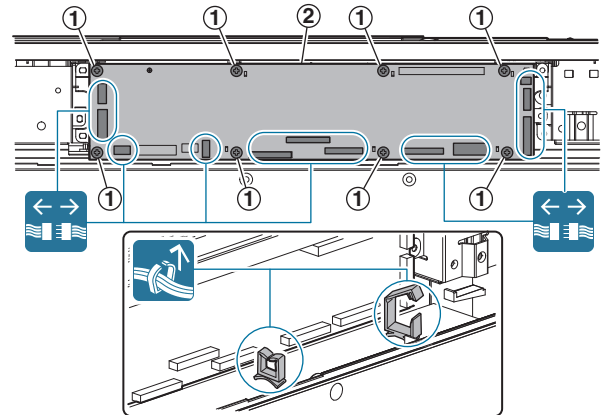

## (2) DC POWER PWB

- 1) Remove the rear cabinet upper.
- 2) Remove the rear cabinet.
- 3) Remove the DC POWER PWB.

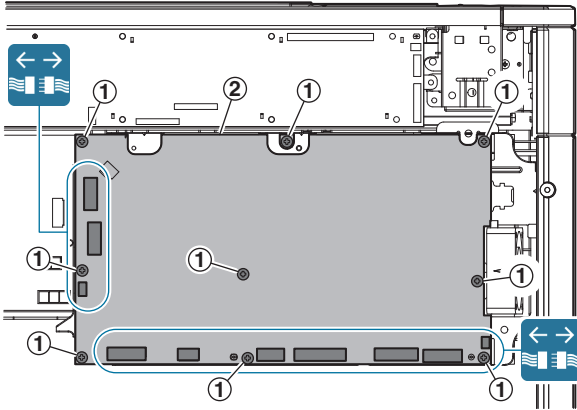

## (3) High voltage PWB (TC PWB)

- 1) Remove the rear cabinet upper.
- 2) Remove the rear cabinet.
- 3) Remove the left cabinet upper.
- 4) Remove the DC POWER PWB unit.

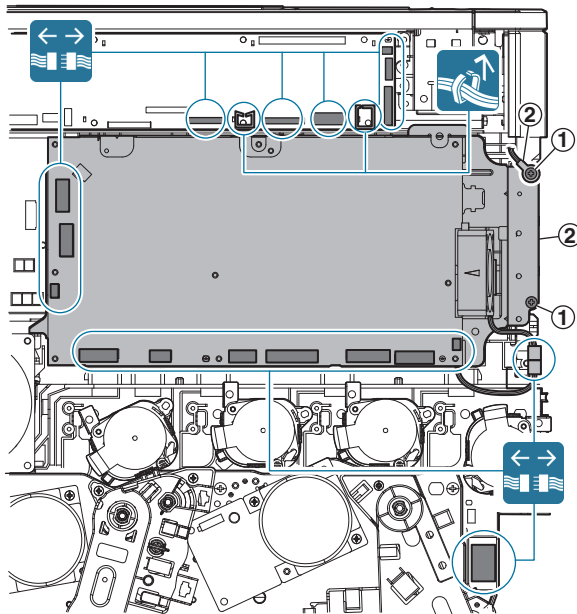

- 5) Remove the high voltage PWB (TC PWB).

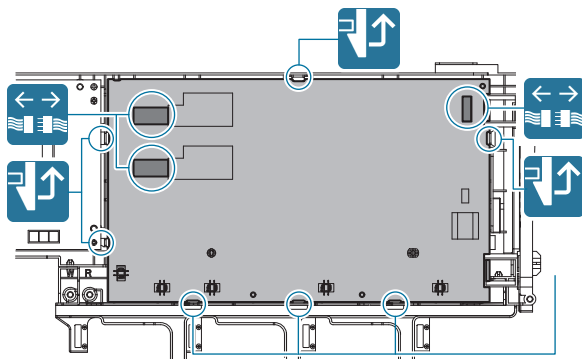

## (4) HL control PWB

- 1) Remove the rear cabinet upper.
- 2) Remove the rear cabinet.
- 3) Remove the ROM cover.
- 4) Remove the DC POWER PWB unit.

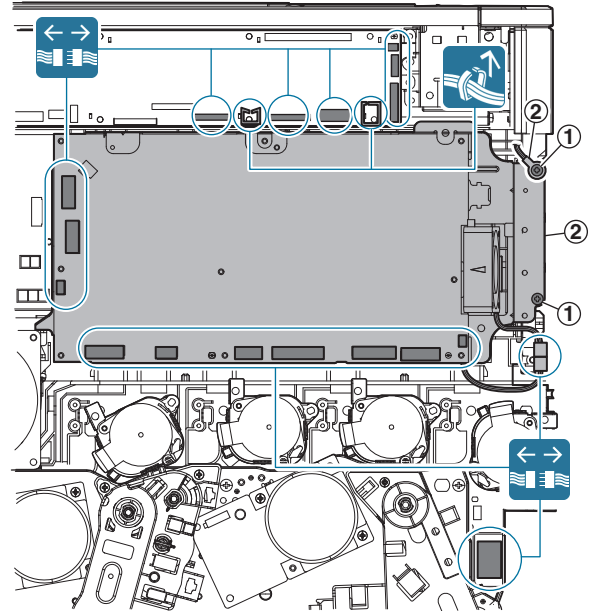

- 5) Remove the HL control PWB.

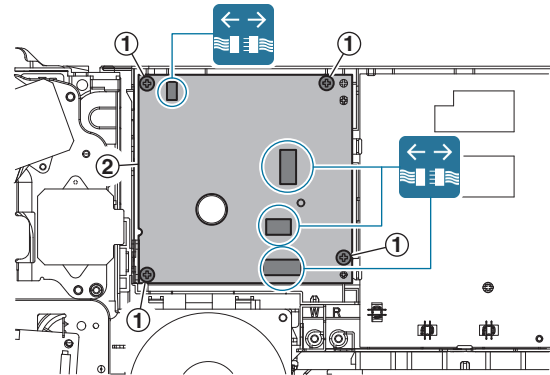

## (5) PCU PWB, High voltage PWB (MC/DV PWB)

- 1) Remove the rear cabinet.
- 2) Remove the PCU PWB.

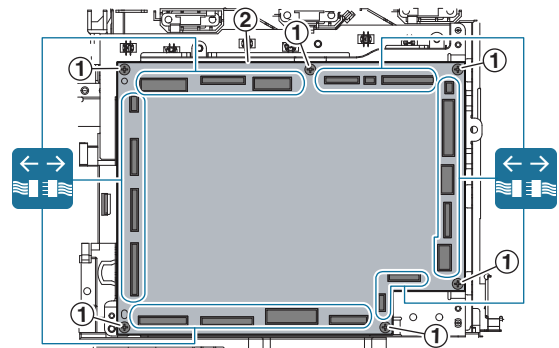

- 3) Remove the left cabinet lower.
- 4) Remove the PCU PWB mounting plate.

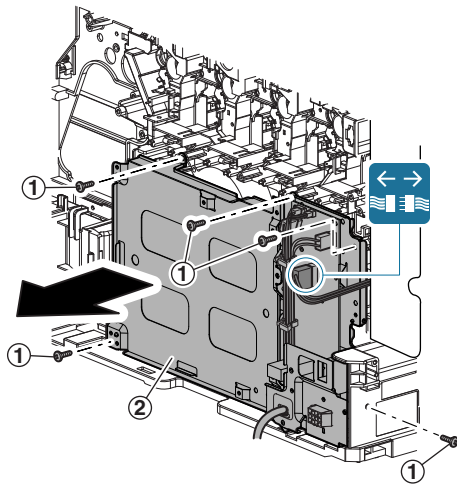

**Important**

Section B

Be careful not to bring the back surface of the PWB into contact with the left guide which is one of the three guides in the lower side of the machine frame.

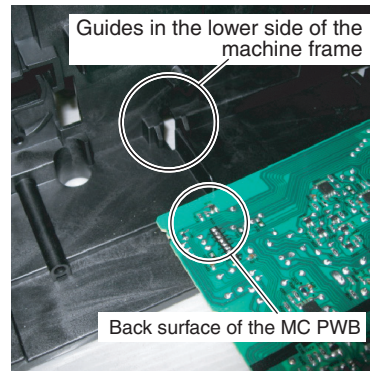

- 5) Remove the high voltage PWB (MC/DV PWB).

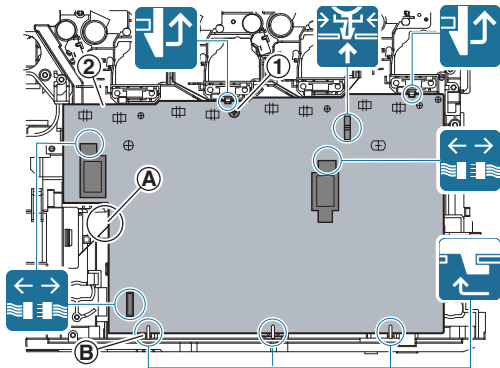

**(6) AC POWER PWB**

- 1) Remove the rear cabinet.
- 2) Remove the left cabinet lower.
- 3) Remove the AC connector plate.

**Important**

Section A

Install so that the left edge of the MC PWB is fitted with the rib of ozone duct cover B.

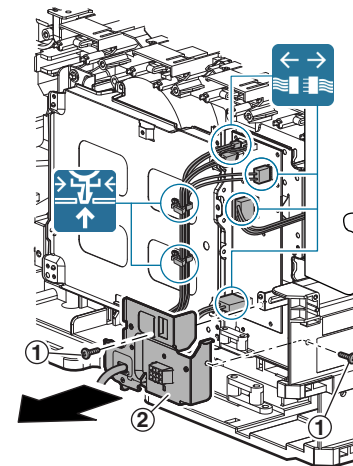
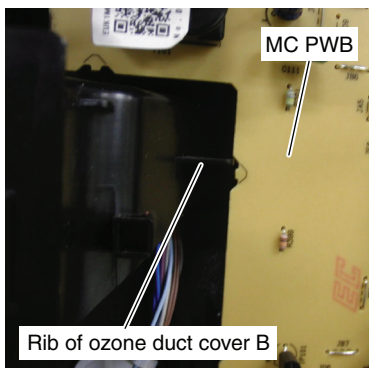

- 4) Remove the AC POWER PWB.

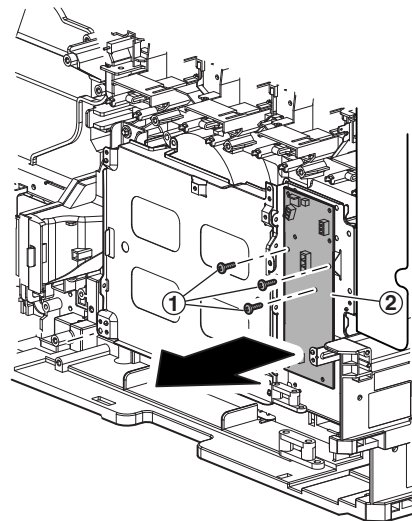

### (7) MFP control PWB

- 1) Remove the left cabinet, and the shield plate.
- 2) Remove the MFP control PWB unit.

**Important**

Since the MFP control PWB and the LSU mother PWB are connected together (board to board), use enough care when removing and attaching them.

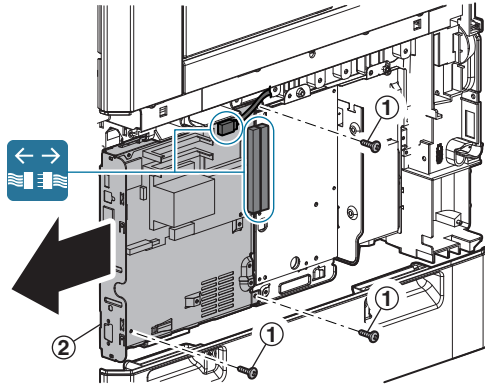

- 3) Remove the MFP control PWB.  
**18cpm/20cpm/23cpm/31cpm(G) machine**

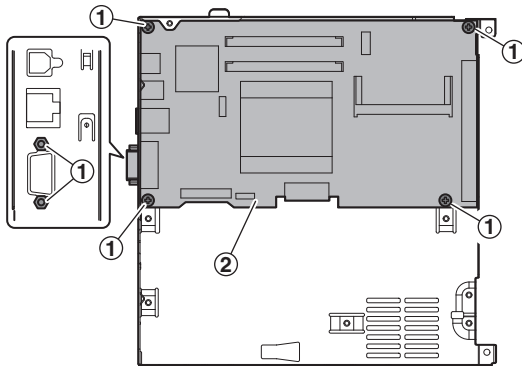

### 26cpm/36cpm/31cpm(A) machine

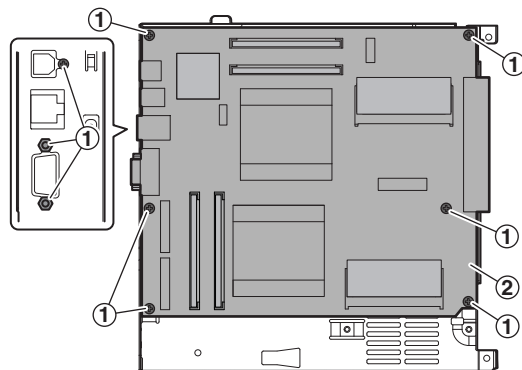

### (8) LSU mother PWB

- 1) Remove the left cabinet, and the shield plate.
- 2) Remove the MFP control PWB unit.

**Important**

Since the MFP control PWB and the LSU mother PWB are connected together (board to board), use enough care when removing and attaching them.

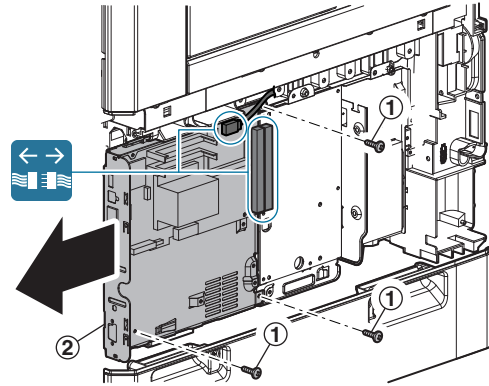

- 3) Remove the LSU mother PWB.

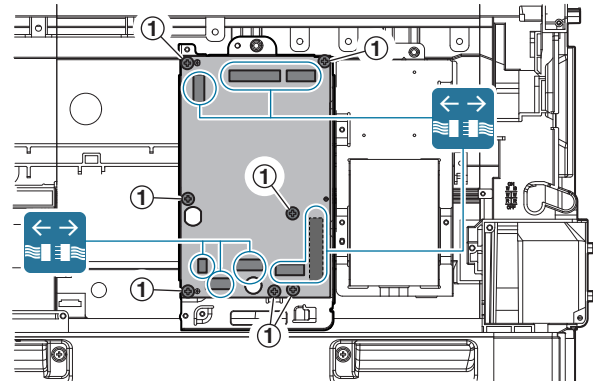



## Q. Filter section

No.	Name
1	Ozone filter

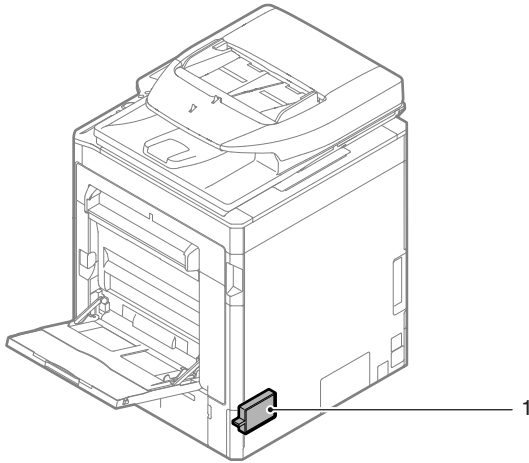

### (1) Ozone filter

- 1) Remove the ozone filter cover.
- 2) Remove the ozone filter.

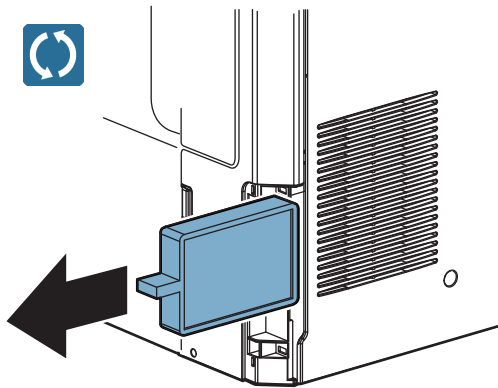

## 2. Disassembly and assembly of each unit

### A. Operation panel section

- (1) Operation panel unit  
(18cpm/20cpm/23cpm/31cpm(G) machine)

No.	Name
1	USB I/F PWB
2	KEY PWB
3	LVDS PWB
4	LCD
5	Touch panel

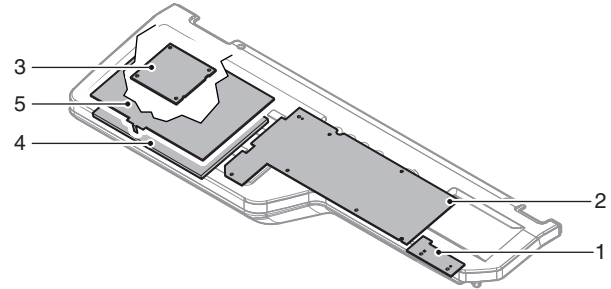

#### a. USB I/F PWB

- 1) Remove the USB I/F PWB.

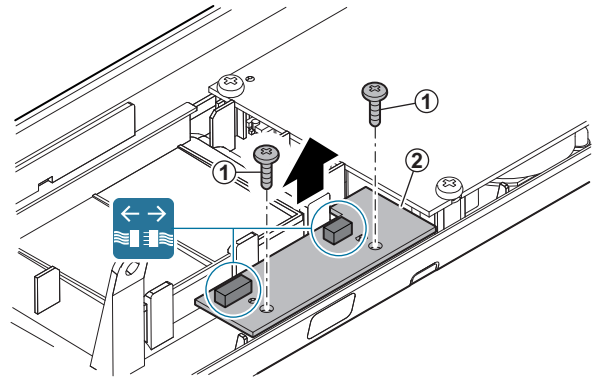

#### b. KEY PWB

- 1) Remove the Mylar, the earth sheet, and remove the KEY PWB.

**Important**

When installing, be careful of the overlapping sequence of the Mylar and the earth sheet.

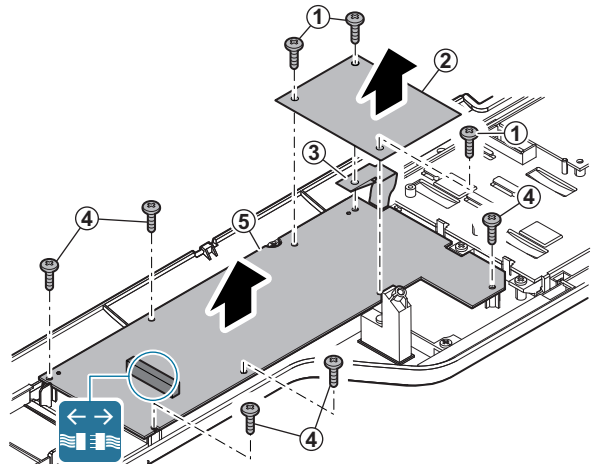

**c. LVDS PWB, LCD, Touch panel**

- 1) Remove the Mylar, the earth sheet. Disconnect the connector, and remove the LVDS PWB.

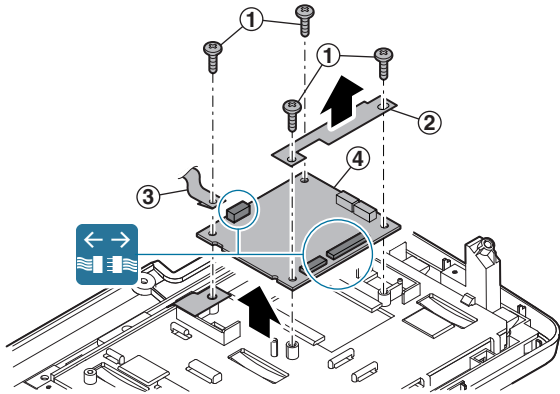

- 2) Remove the earth sheet from the KEY PWB, and remove the LCD holder.

**Important**

When installing, be careful of the overlapping sequence of the earth sheet.

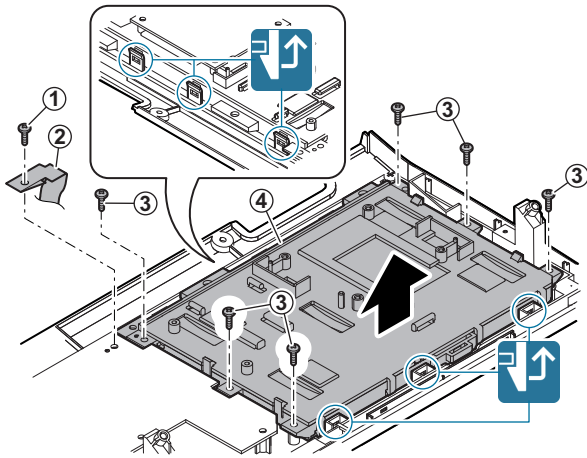

- 3) Remove the holder, and remove the LCD.

**Important**

Use enough care not to put finger prints on the LCD surface.

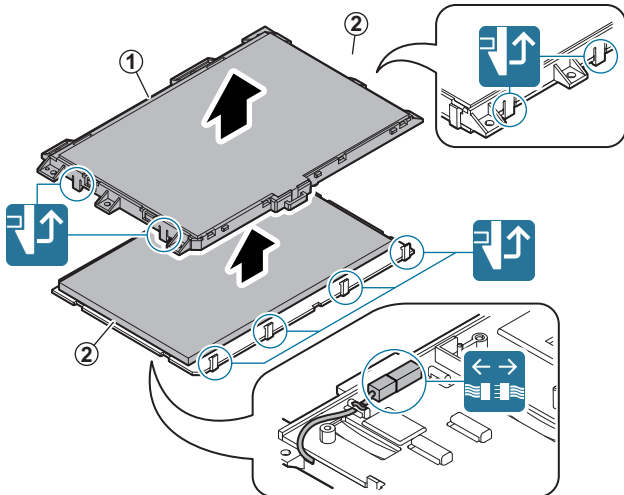

- 4) Remove the touch panel.

**Important**

Use enough care not to put finger prints on the touch panel surface.

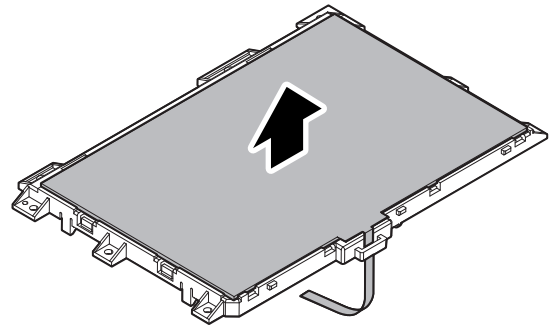

**(2) Operation panel unit (26cpm/36cpm/31cpm(A) machine)**

No.	Name
1	USB I/F PWB
2	LVDS PWB
3	KEY PWB
4	LCD PWB
5	Touch panel

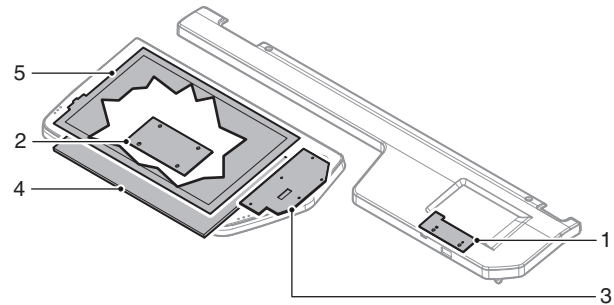

**a. USB I/F PWB**

- 1) Remove the USB I/F PWB.

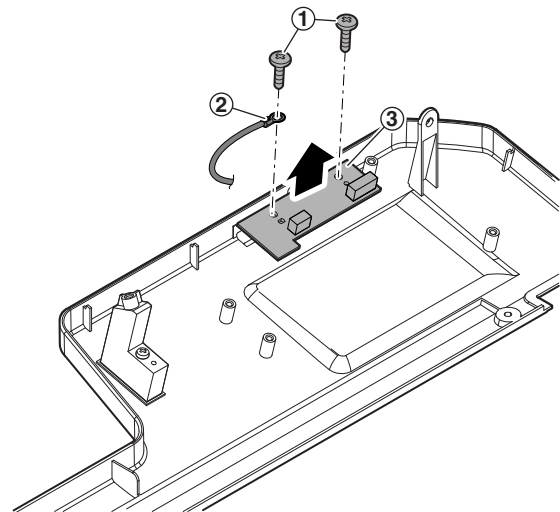

**b. LVDS PWB**

- 1) Disconnect the connector, and remove the LVDS PWB.

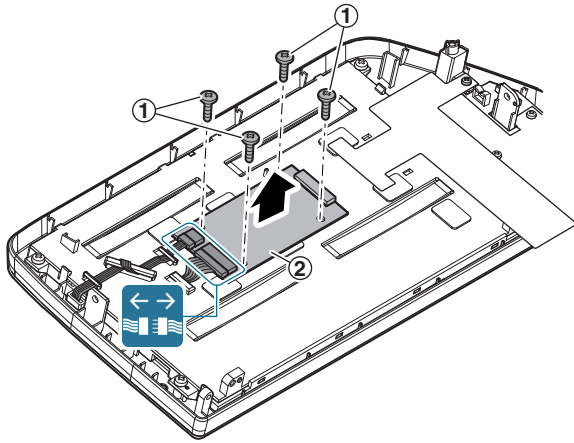

**c. KEY PWB, LCD, Touch panel**

- 1) Remove the Mylar. Disconnect the connector, and remove the KEY PWB.

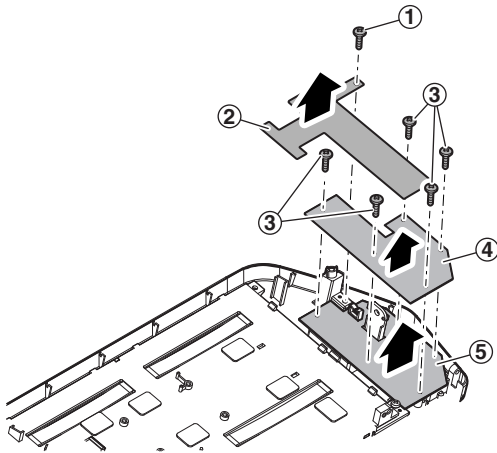

- 2) Remove the LCD holder.

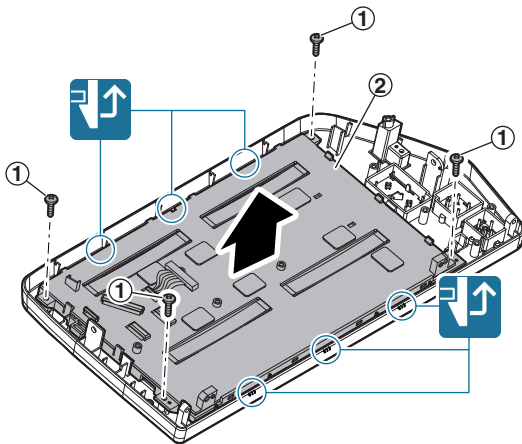

- 3) Remove the holder, and remove the LCD.

**Important**

Use enough care not to put finger prints on the LCD surface.

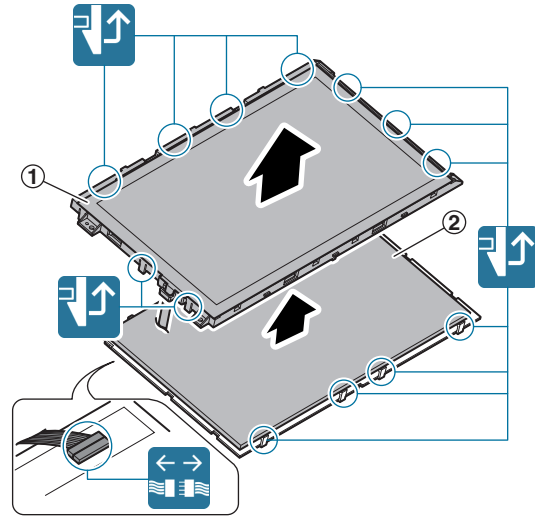

- 4) Remove the touch panel.

**Important**

Use enough care not to put finger prints on the touch panel surface.

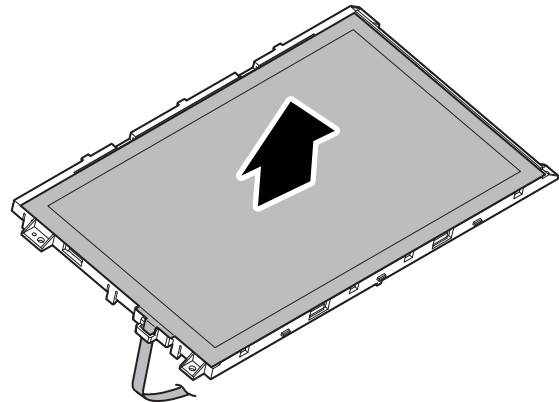

## B. RSPF section

### (1) RSPF unit

No.	Name
1	Document pickup roller
2	Paper feed roller
3	Separation roller
4	Torque limiter SPF
5	Take-up torque limiter
6	Discharge brush
7	Registration roller
8	OC mat

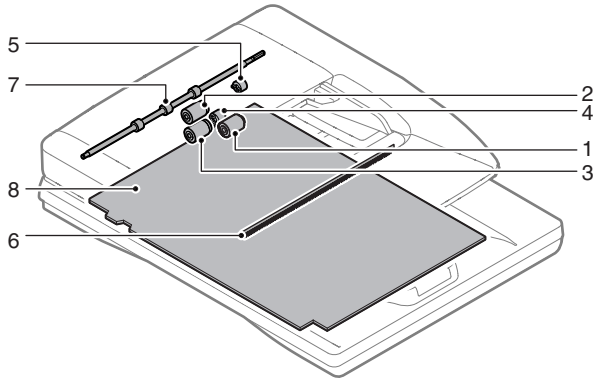

#### a. Document pickup roller, Paper feed roller

- 1) Open the paper feed unit, and remove the cover.

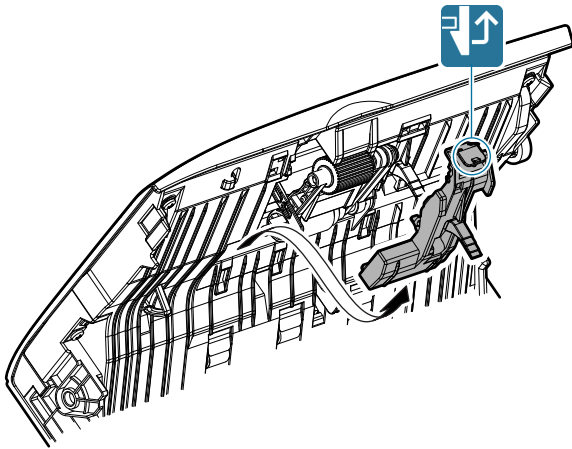

- 2) Remove the holder, and remove the document pickup roller, and the paper feed roller.

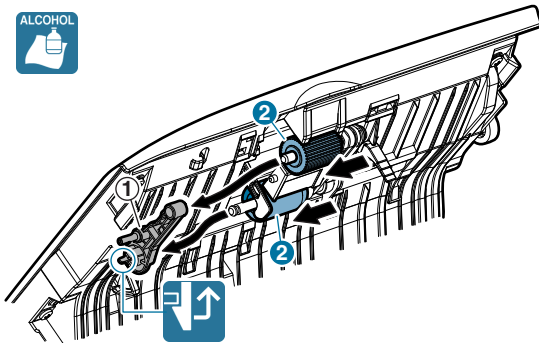

#### b. Separation roller, Torque limiter SPF

- 1) Open the paper feed unit, and remove the cover.

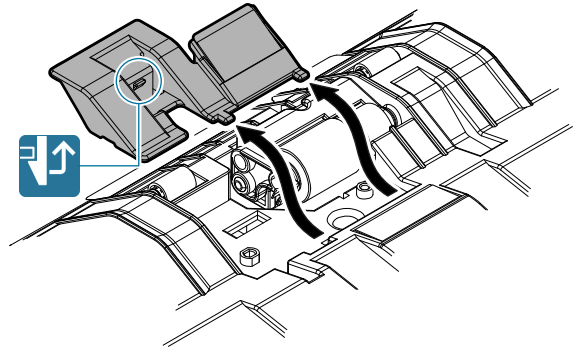

- 2) Remove the holder, and remove the separation roller.

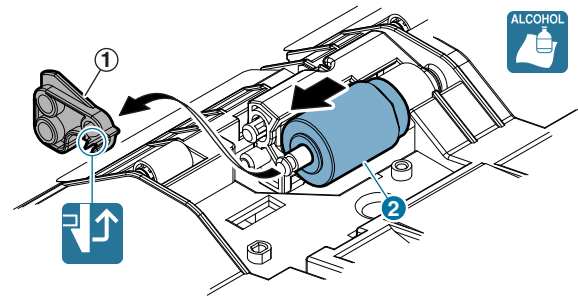

- 3) Remove the torque limiter SPF.

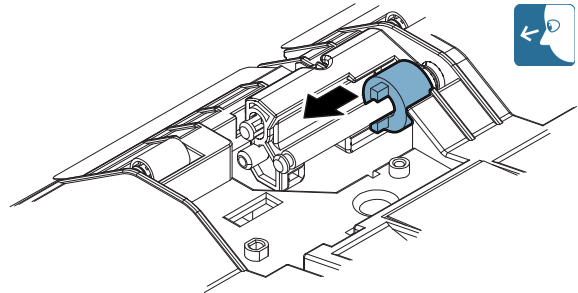

#### c. Take-up torque limiter

- 1) Remove the one-way coupling, the belt, and the pulley. Remove the E-ring. Pull out the shaft, and remove the bearing, the holder, and the take-up torque limiter.

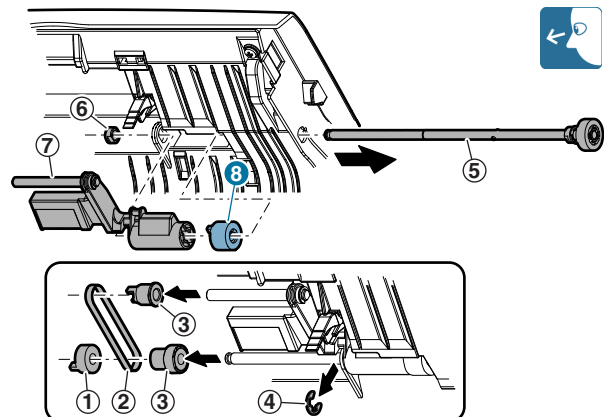

**d. Discharge brush**

- 1) Open the document tray, and remove the discharge brush.

**Important**

When replacing the discharge brush, attach a new brush to the reference.

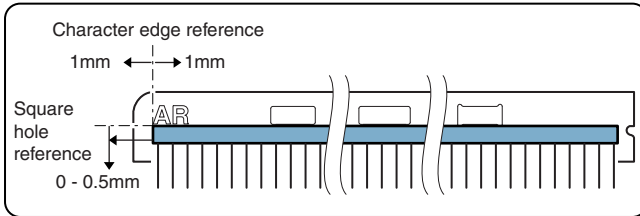
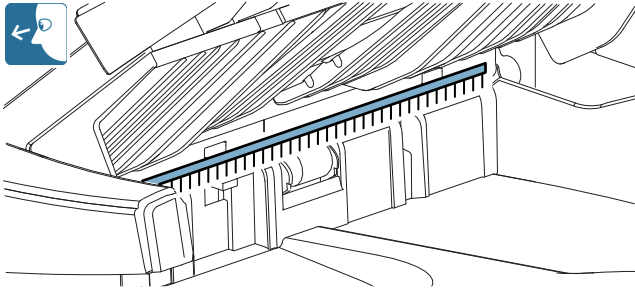

**e. Registration roller**

- 1) Open the paper feed unit, and clean the registration roller.

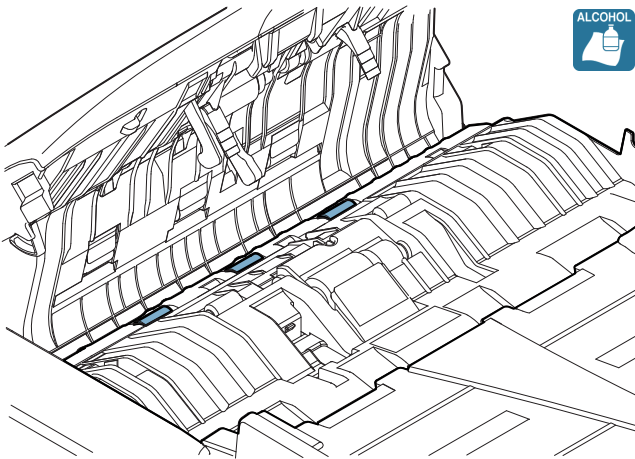

**f. OC mat**

- 1) Open the RSPF unit, and clean the OC mat.

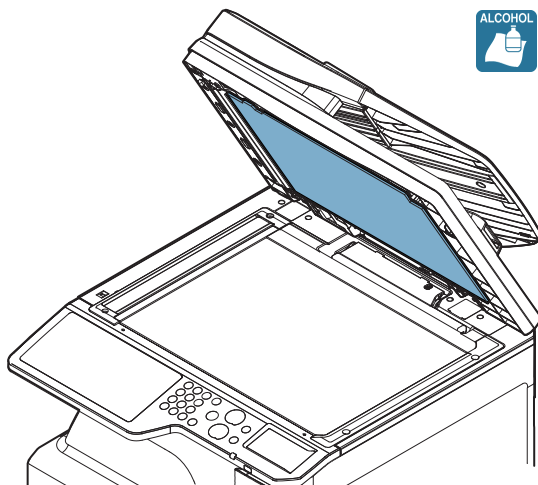

**(2) RSPF transport unit**

No.	Name
1	Transport roller 2
2	Transport roller 3
3	Paper exit roller
4	Scan plate

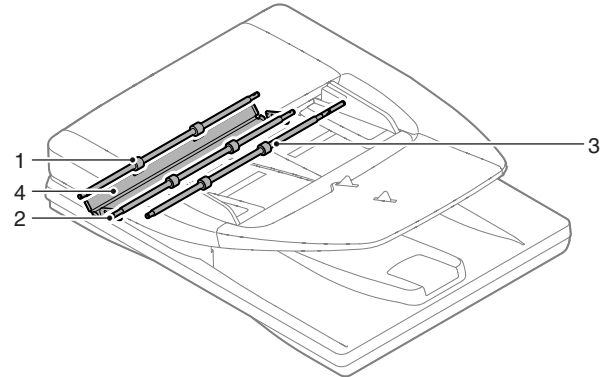

**a. Transport roller 2, Transport roller 3, Paper exit roller**

- 1) Clean the transport roller 2, the transport roller 3, and the paper exit roller

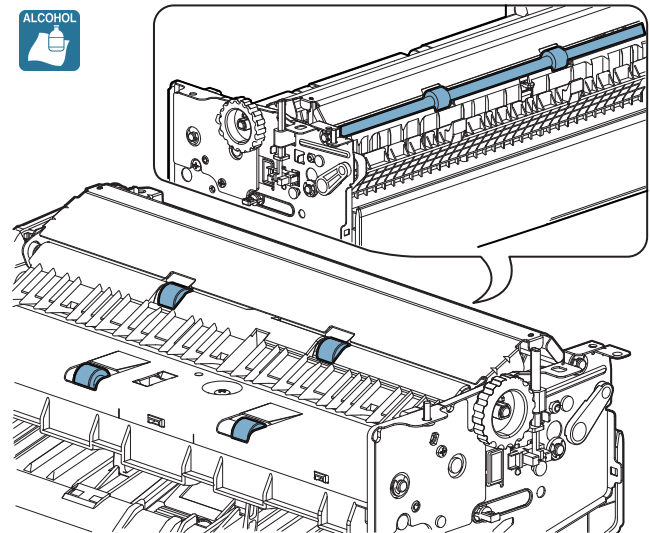

**b. Scan plate**

- 1) Clean the scan plate.

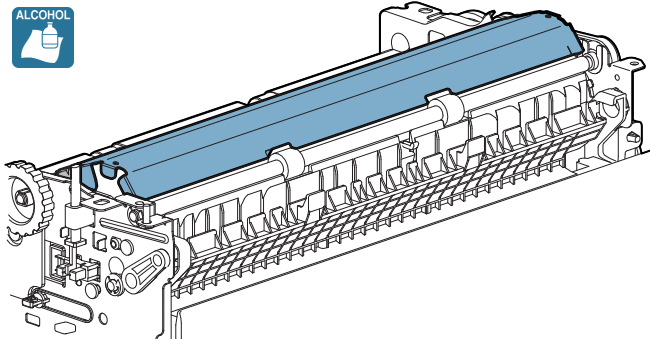

## C. Scanner section

### (1) Scanner unit

No.	Name
1	Drive belt
2	Drive wire
3	Rails
4	Mirror
5	Reflector
6	Scanner lamp
7	Lens
8	CCD
9	Table glass
10	SPF glass
11	LED PWB
12	LED driver PWB

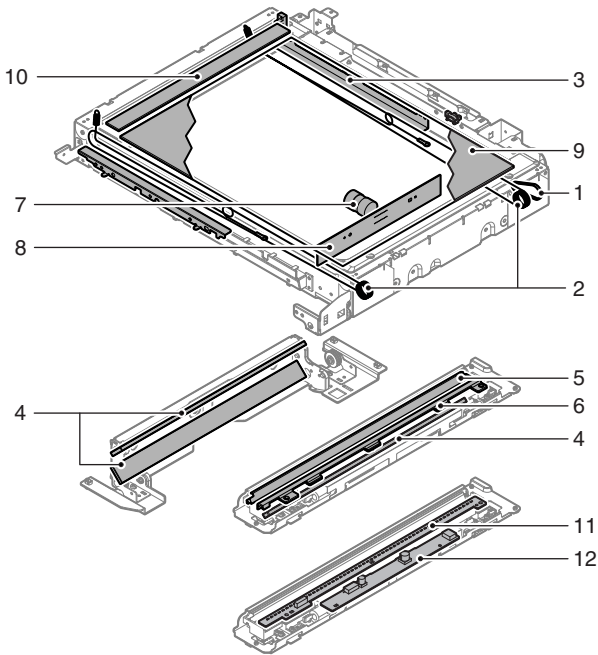

#### a. Drive belt, Drive wire

- 1) Remove the table glass.
- 2) Check the tension of the drive belt and the drive wire. Check to confirm that the drive wire in the winding pulley is wound without clearance.

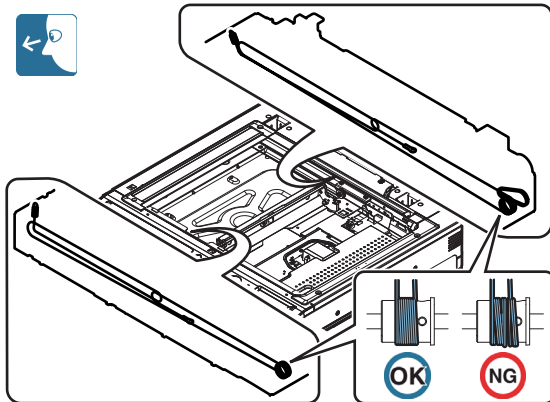

### Important

Wind the drive wire in the sequence of 1 to 7 as shown in the figure below and fix it.

When winding the drive wire around the pulley, shift the mirror unit to the vicinity of the home position, and wind 7 turns as shown in the figure, and fix the 8th turn with a screw. Then wind two turns furthermore around the pulley.

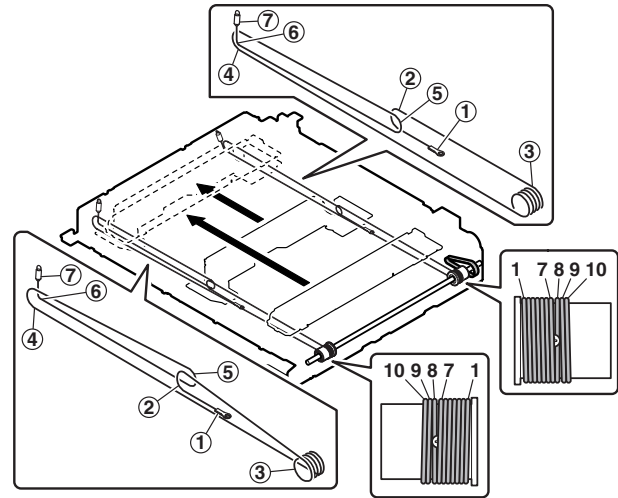

#### b. Rails

- 1) Remove the table glass.
- 2) Grease each rail.

### Important

Be careful not to allow grease to come in contact with drive wires.

If grease contacts drive wires, clean wires thoroughly.

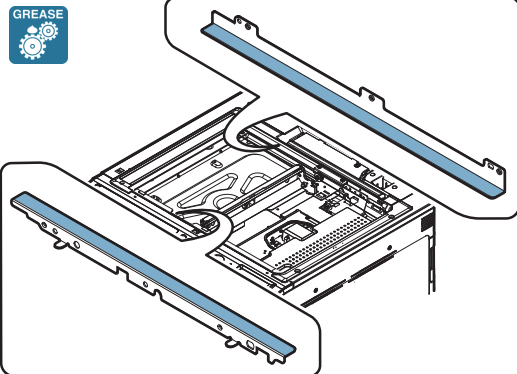

#### c. Mirror, Reflector, Scanner lamp

- 1) Remove the table glass.
- 2) Clean the No. 2 mirror, and the No. 3 mirror.

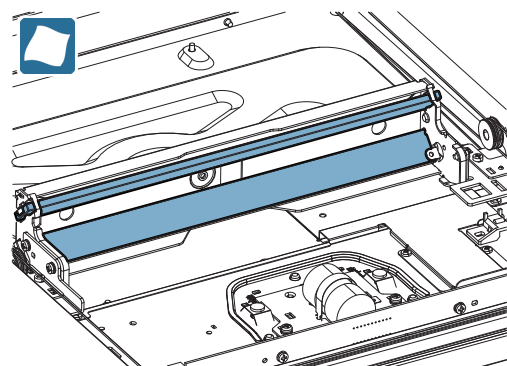

- 3) Clean the reflector, the scanner lamp, and the No. 2 mirror.

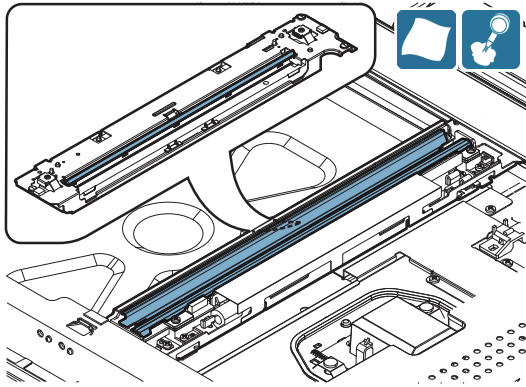

**d. Lens, CCD**

- 1) Remove the table glass.
- 2) Remove the dark box, and the cover.

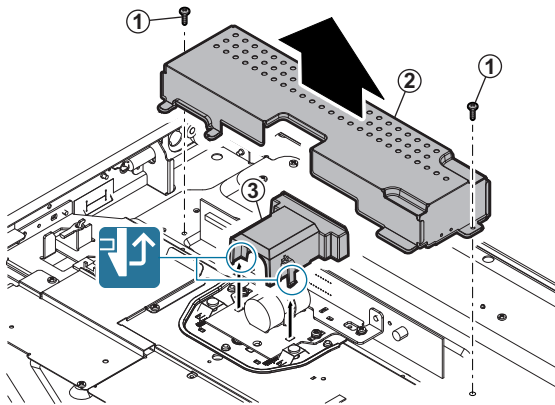

- 3) Clean the lens, and the CCD.

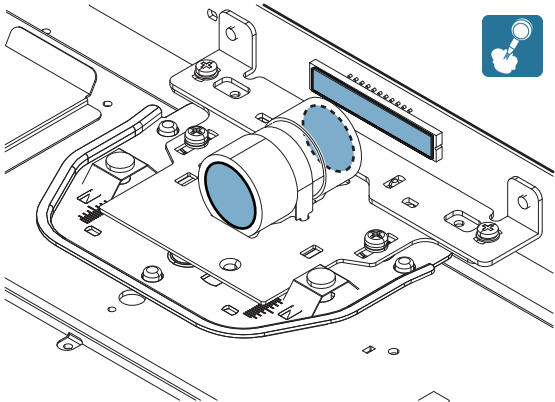

**e. Table glass, SPF glass**

- 1) Remove the glass holder, and the table glass. Remove the table glass, and the SPF glass.

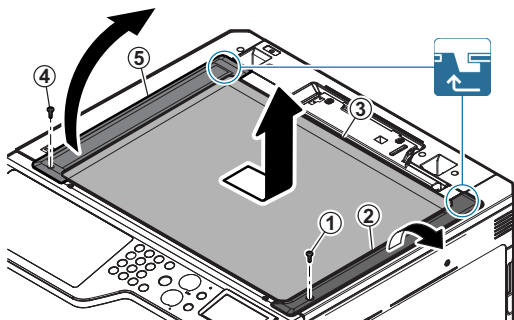

- 2) Clean the both surfaces of the table glass, and the SPF glass.

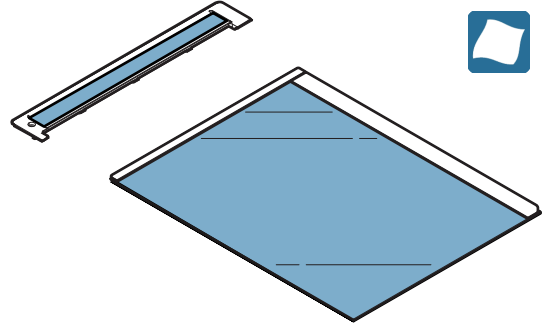

**f. LED PWB, LED driver PWB**

- 1) Remove the table glass.
- 2) Shift the lamp unit to the notch section of the scanner base plate.

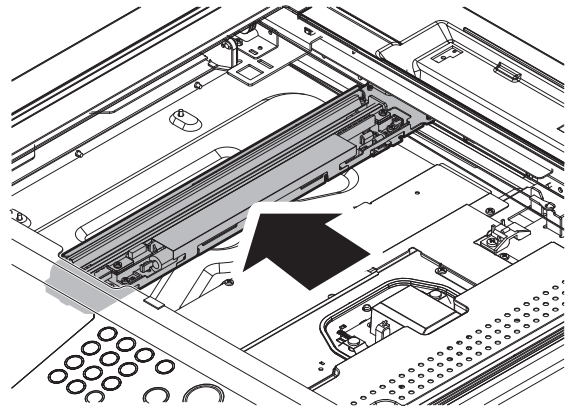

- 3) Turn over the sheet.

**Important**

When attaching the sheet to the original position, insert the L-shape sections into the inside of the metal plate and attach the center portion to the metal plate with double-stick tape.

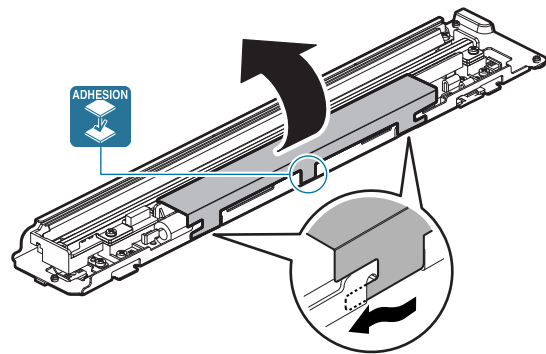

- 4) Remove the lamp guide. Disconnect the connector from the LED driver PWB.

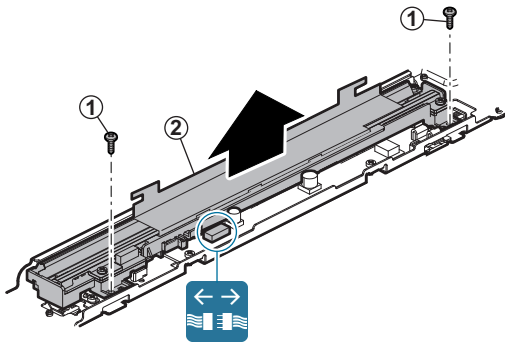

- 5) Remove the scanner lamp, and the LED PWB. Disconnect the connector from the LED PWB.

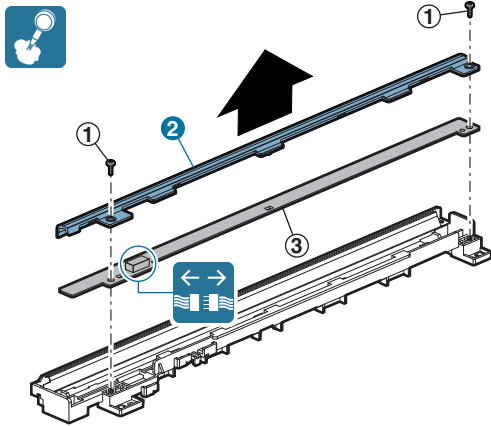

- 6) Remove the harness holder, and remove the flat cable from the LED driver PWB. Remove the LED driver PWB.

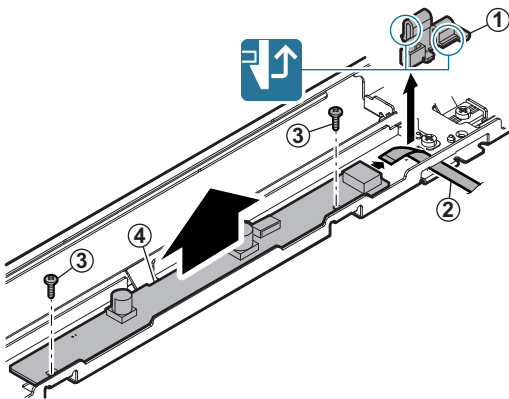

## D. Developing section

### (1) Developing unit

No.	Name
1	Developer
2	DV seal
3	DV side seals F/R
4	Toner filter

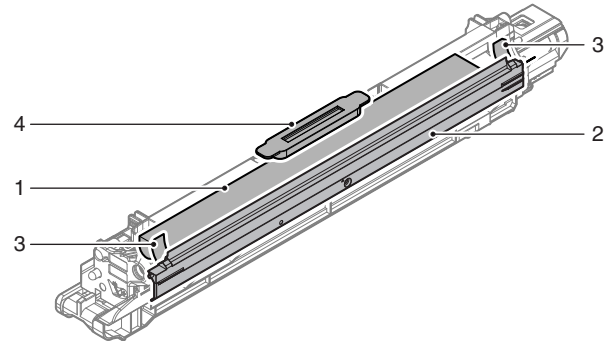

#### a. Developer

- 1) Open the cover, and remove the developing unit.

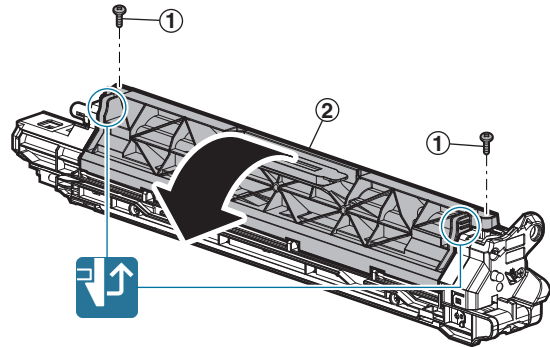

#### Important

There are two types of the developing unit; (1) the DV cover is fixed with the DV cover fixing screw, and (2) the DV cover is fixed with a hook only.

For the type where the DV cover is fixed only a hook, do not use a screw for fixing.

Otherwise, the DV roller may be damaged.

For the type where the DV cover is fixed with the fixing screw, there is a groove in the fixing screw hole section as shown in the figure below.

In some production lots, a sheet is attached instead of this.

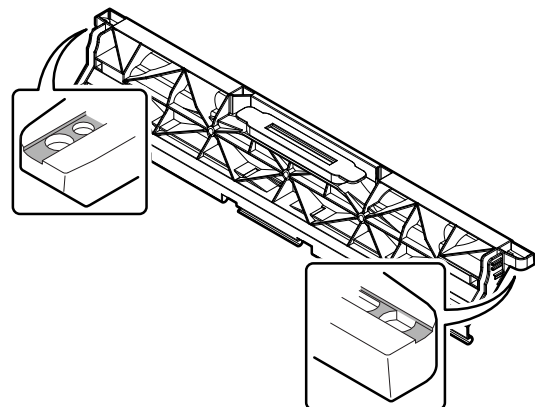



2) While rotating the gear, dispose of developer.

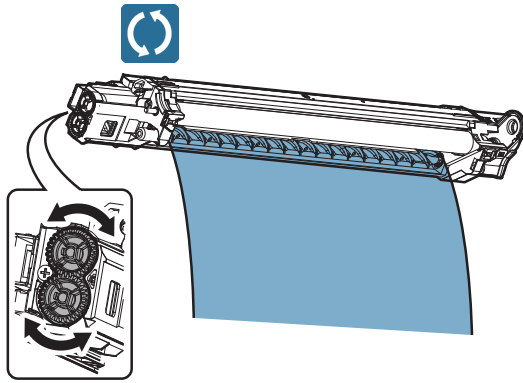

**Important**

Thoroughly clean developer unit so that no developer remains in the unit. Be careful not to scratch the MG roller.

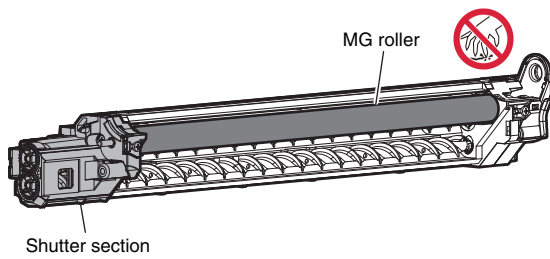

3) Loading developer to the developing units.

**Important**

Be sure to shake the bag of developer thoroughly before pouring into the developing unit.

**Important**

When pouring the developer into the unit, use care to not get developer in to the drive section.

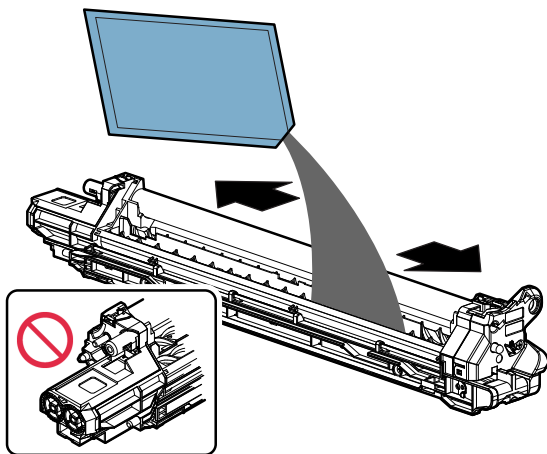

4) Install the cover.

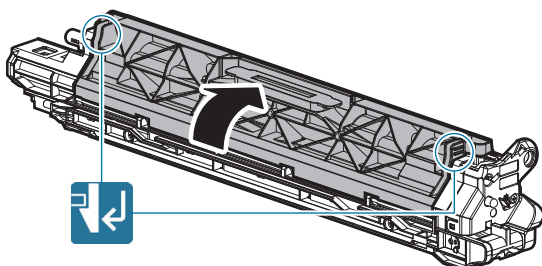

5) Shake the developing unit several times horizontally and strongly.

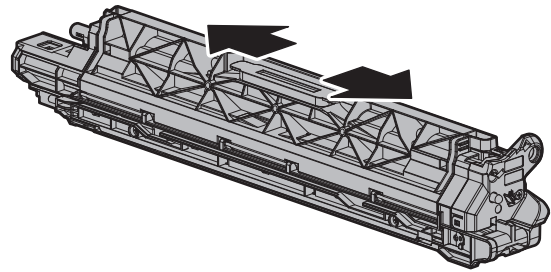

6) Open the toner shutter of the developing unit and check to confirm that there is proper amount of developer. If not, perform procedure 5) again.

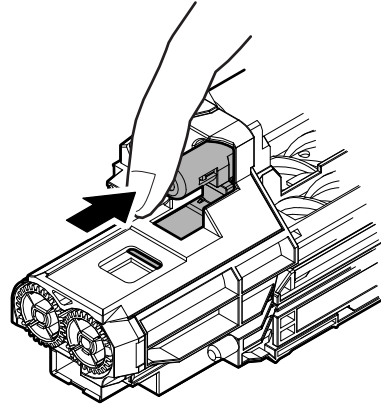

- Check that there is proper amount of developer. (The stirring screw can be partly seen.)

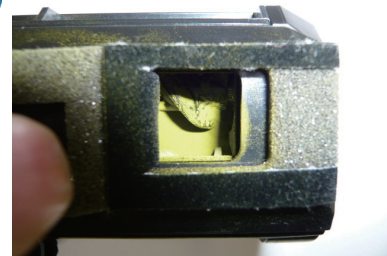

- There is no developer in the shutter position.



- There is too much developer.  
(The stirring screw cannot be seen.)

NG

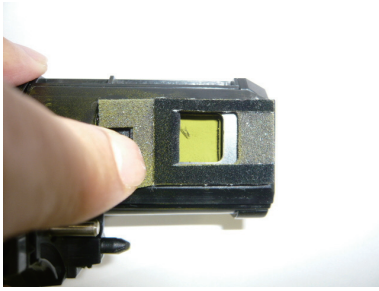

**Important**

Be sure to keep the developing unit level while supplying the developer.

- 7) Insert the developing unit so as not to give a strong shock to the main unit.

**Important**

Slide the developing unit horizontally into the machine, in the direction of the arrow, until developing unit locks into place. Do not push the unit diagonally, as contact with the drum may occur causing damage.

**Important**

When removing or installing the developing unit, put your hand from below the unit and slide it in parallel along the guide. At that time, be careful not to touch the roller surface.

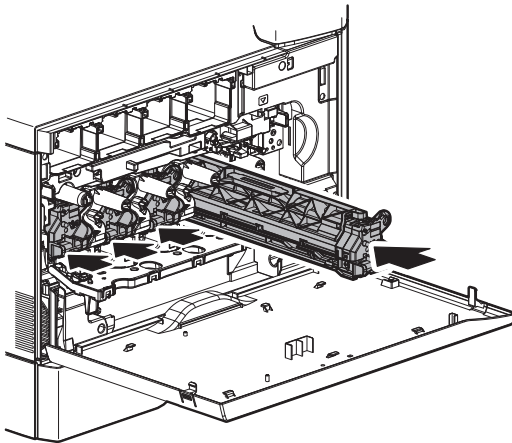

**Important**

When performing the above operation, there is no need to uninstall or install the OPC drum unit. If it must be uninstalled or installed for any reason, follow the procedures below. When uninstalling or installing the OPC drum unit, put your hand from below the unit and slide it in parallel along the guide on the right side.

At that time, be careful not to touch the OPC drum surface.

- 8) Set the ADJ 1C toner density control reference value.

## b. DV seal

- 1) Remove the DV seal.

**Important**

Remove the cover with a screwdriver (-) from the rear side. At that time, be careful not to break the boss on the front side.

**Important**

When attaching the DV seal to the cover, use care and do not wrinkle the seal.

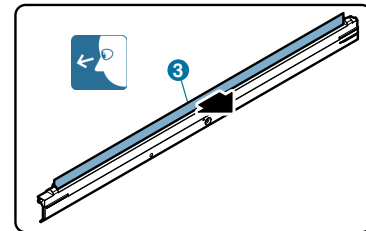
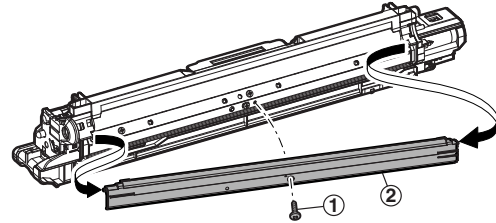

## c. DV side seals F/R

- 1) Remove the DV side seals F/R.

**Important**

When replacing the toner DV side seals F/R, attach a new one to the reference.

**Important**

Before attaching a new seal, be sure to remove foreign materials or remained adhesive completely from the attachment surface.

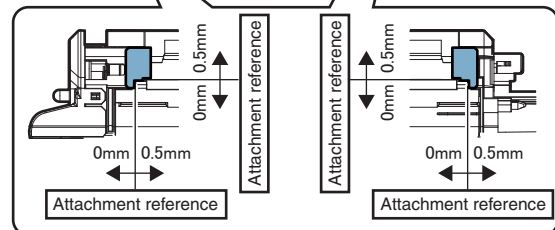
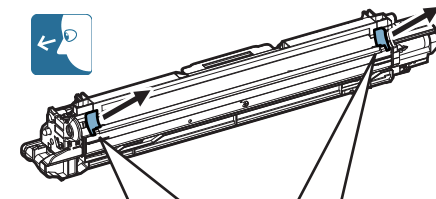

#### d. Toner filter

- 1) Remove the toner filter.

**Important**

When attaching the toner filter, be sure filter is completely seated.

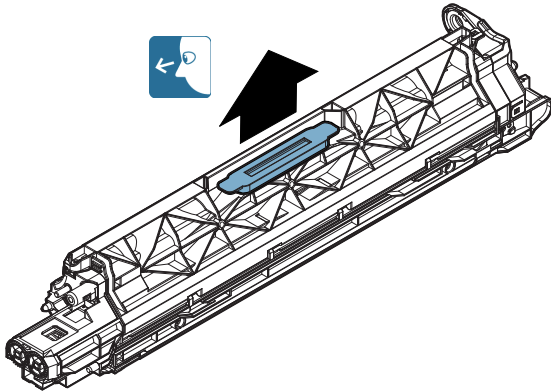

#### E. OPC drum section

##### (1) OPC drum unit

No.	Name
1	Drum
2	MC unit
3	Cleaning blade
4	Toner reception blade
5	Side seals F/R

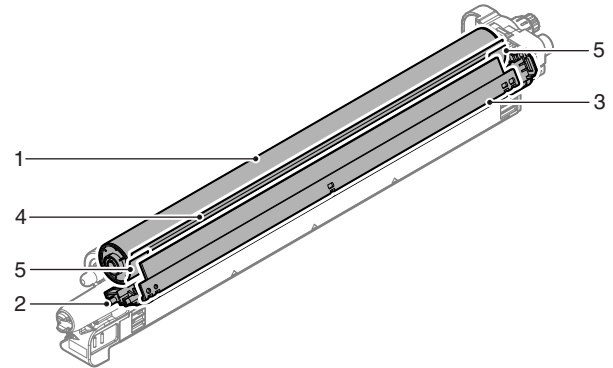

##### a. Drum

- 1) Rotate the OPC drum drive gear in the arrow direction (clockwise) to release the drum shaft lock.

**Note**

When locking or releasing the lock of the drum shaft, check the direction of rotating the drum drive gear indicated on the drum holder on the rear frame side.

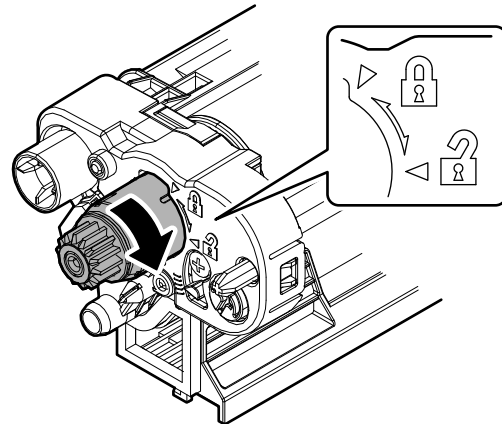

- 2) Insert a small screwdriver or a hex wrench into the hole in the shaft cover on the opposite side of the OPC drum drive gear, and push it in the arrow direction to pull out the drum shaft.

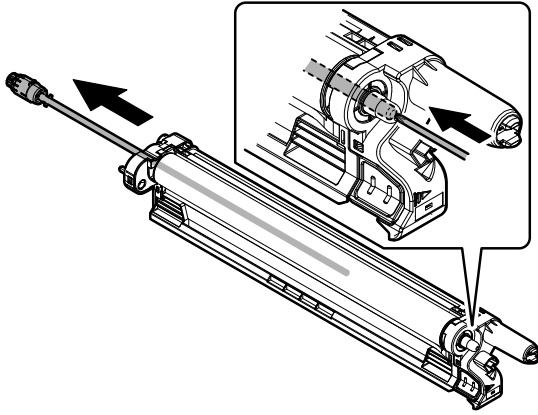

**Note**

In order to improve the image quality, the backlash between the OPC drum shaft and the OPC drum is minimized in this machine. To pull out the OPC drum shaft, therefore, follow the above procedure.

**Important**

Note that conduction grease is applied to the shaft on the OPC drum drive gear side. Be careful not to attach conduction grease to the OPC drum surface.

- 3) Remove the drum.

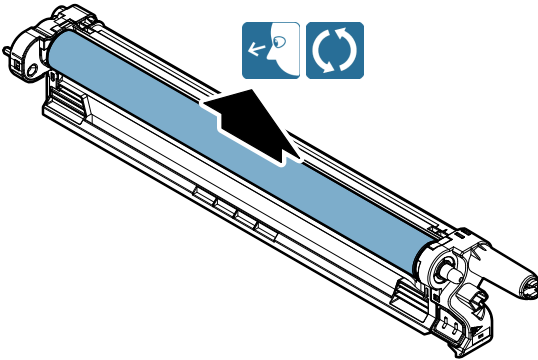

**Important**

When assembling the drum shaft, set the projection with an opening for the drum drive gear to the position shown in the figure, and push the drum shaft inside. Then, rotate the drum drive gear in the arrow direction (counterclockwise) to lock it. Check to confirm that the projection of the drum drive gear is securely in the drum holder.

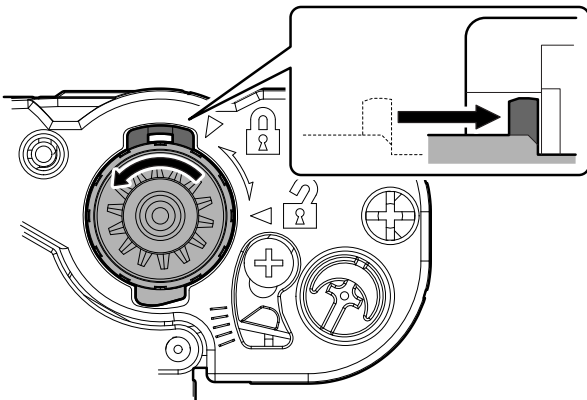

**Important**

**Note for servicing the OPC drums**

**1. Prevent contamination**

**Note**

- Be careful not to leave fingerprints or oily dirt on the OPC drum surface. (Keep the unit away from oils and dust.)
- When replacing the OPC drum, cover the OPC drum with the protection sheet and hold the protection sheet.

If it is required to hold the OPC drum directly, use enough care not to touch the cleaning blade area, 5mm inside from both edges of the OPC drum. (If a fingerprint or oily dirt is attached to the cleaning blade area of the OPC drum, the cleaning blade may flip.)

**Countermeasures**

If a fingerprint is attached to the OPC drum surface erroneously, perform the following countermeasures.

- 1) Use dry cloth to clean and remove the dirt.
- 2) Apply stearic acid powder to prevent blade flip.

**Check method**

Check to confirm that the OPC drum is free from fingerprints or oily dirt and that the cleaning blade is completely cleaned by the following method.

- Make a print of a half tone image on all the surface of A4 (11" x 8.5") paper, and check the printed paper for any abnormality in the image.

**2. Prior exposure prevention**

**Note**

- Avoid servicing in a place where there is strong light.
- Do not expose the unit to light for a long time.
- Cover the OPC drum with light-blocking material. (When using paper, use about 10 sheets of paper to block light.)

**Countermeasures**

If the OPC drum is erroneously exposed to light too much (prior exposure), perform the following countermeasures.

- 1) Print half tone images on the whole surface of A4 (11" x 8.5") paper, and check to confirm that there is no irregular density area in the previously exposed section.
- 2) If the OPC drum is subject to stress by being exposed to strong light, it may be recovered by leaving it in a dark and cool place.

If it may not be recovered, replace it with a new one.

### b. MC unit

- 1) Remove the cover, and slide the MC unit to the rear side to remove.

**Important**

When replacing the MC unit, do not touch the MC grid surface.

**Important**

When attaching the cover, check to confirm that the seat attached to the cover is not in contact with the MC grid.

**Important**

Check to confirm that the MC grid of the MC unit is not in contact with the lens and that it is not deformed.

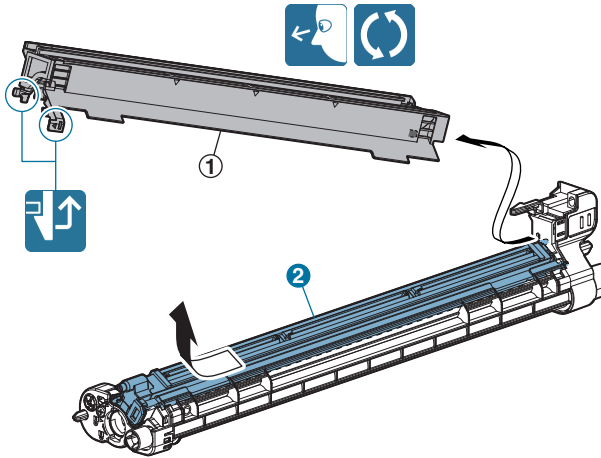

### c. Cleaning blade

- 1) Remove the lens. Remove the cleaning blade.

**Important**

When toner is attached to the lens, wipe with dry cloth or cloth immersed in alcohol.

**Important**

Do not touch the tip of the cleaning blade.

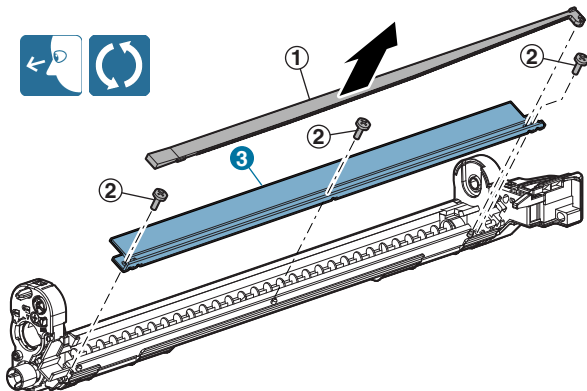

### d. Toner reception blade

- 1) Remove the toner reception blade.

**Important**

When replacing the toner reception blade, attach a new one to the reference.

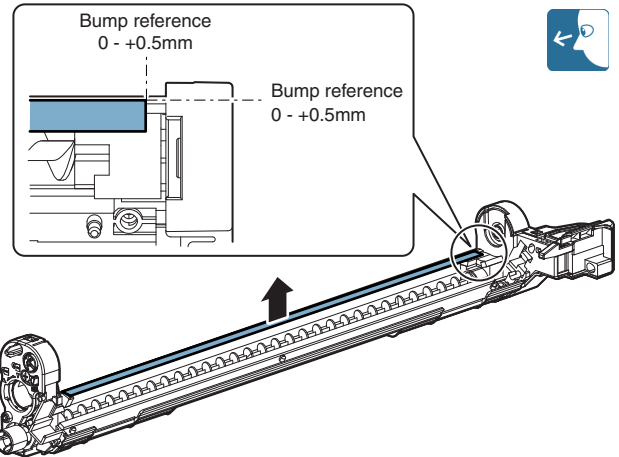

### e. Side seals F/R

- 1) Remove the side seals F/R.

**Important**

When replacing the side seals F/R, attach the cleaning blade in advance, then attach a new seal to the reference.

**Important**

Thoroughly clean the frame surface of any old glue residue before attaching the new seals.

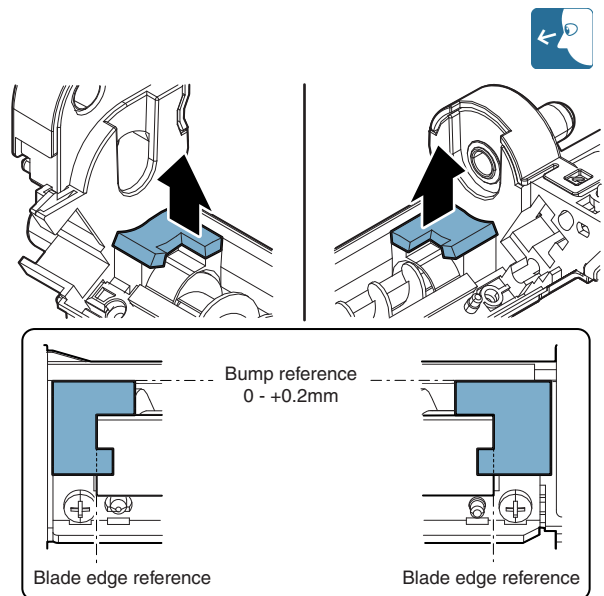

**Important**

When the OPC drum is removed, perform the following procedures.

- 1) After removing the OPC drum, apply stearic acid powder (UKOG-0312FCZZ) to the whole surface of the OPC drum.

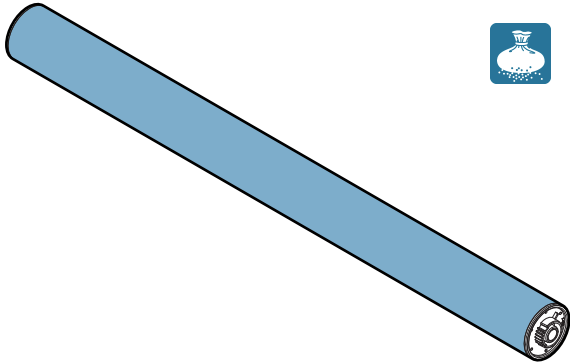

- 2) After attaching the OPC drum to the OPC drum frame, use the black protect sheet or copy paper, and manually rotate the OPC drum two turns in the forward direction to remove stearic acid powder applied to the OPC drum surface.

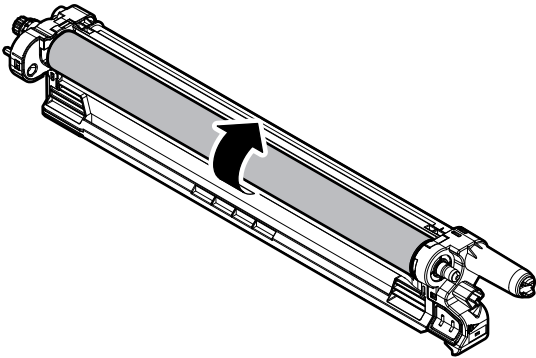

- Do not touch the OPC drum surface except for the both ends (5mm) of the OPC drum.
- Any section of the OPC drum may be touched from above the black protect sheet, but do not touch too strongly.

**(2) MC cleaning rod**

No.	Name
1	Charger cleaner

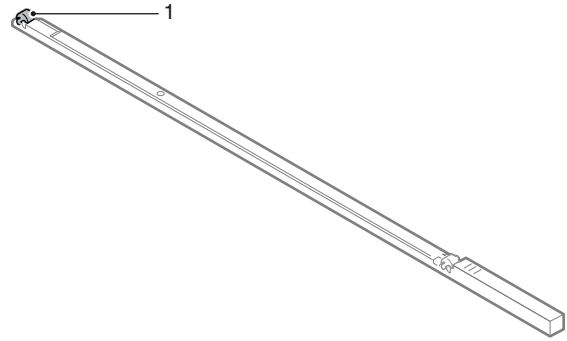

**a. Charger cleaner**

- 1) Open the front cabinet, and remove the MC cleaning rod.

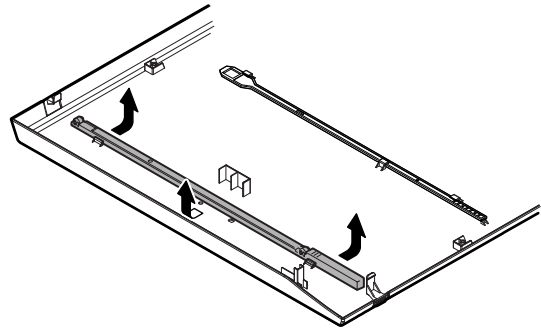

- 2) Remove the charger cleaner at the lead edge of the MC cleaning rod, and attach a new charger cleaner.

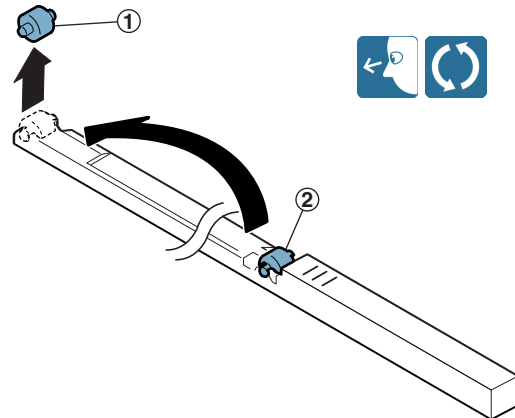

## F. Transfer section

### (1) Primary transfer unit

No.	Name
1	Separation pawl
2	Primary transfer belt
3	Secondary transfer drive transmission gear
4	Primary transfer belt drive roller
5	Primary transfer belt follower roller
6	Primary transfer belt tension roller
7	Registration backup roller
8	Y auxiliary roller
9	PTC backup roller
10	Primary transfer roller

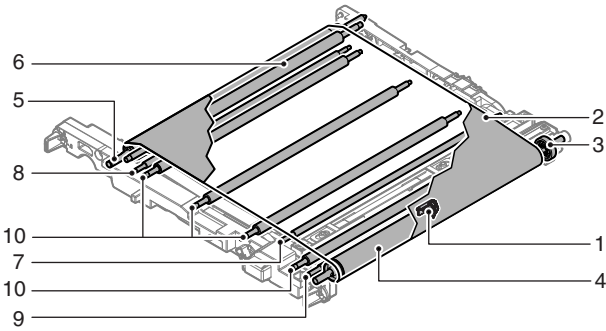

#### a. Separation pawl, Primary transfer belt

- 1) Remove the paper guide.

**Important**

After removing the paper guide, place it so that the separation pawl faces upward in order to protect the separation pawl tip from damages.

In addition, when attaching the paper guide, be careful not to damage the transfer belt by the separation pawl.

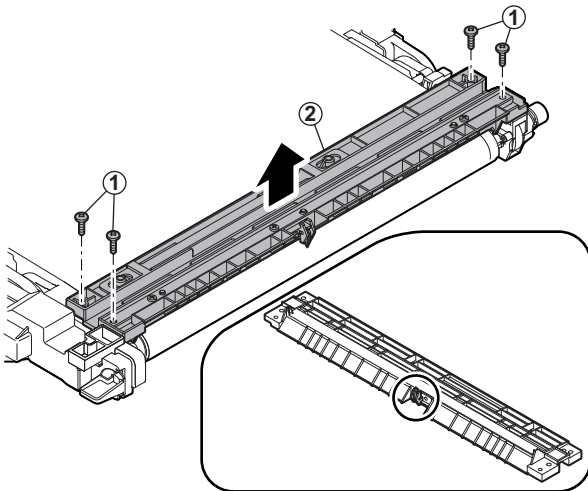

- 2) Remove the separation pawl from the paper guide.

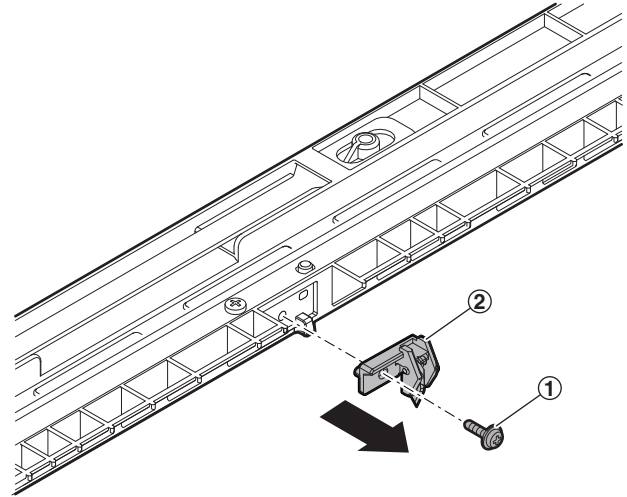

- 3) Remove the primary transfer unit.
- 4) Fold the primary transfer unit, and remove the primary transfer belt.

**Important**

The length of the mounting screw on the front side differs from that on the rear side. The screw on the rear side is longer than that on the front side.

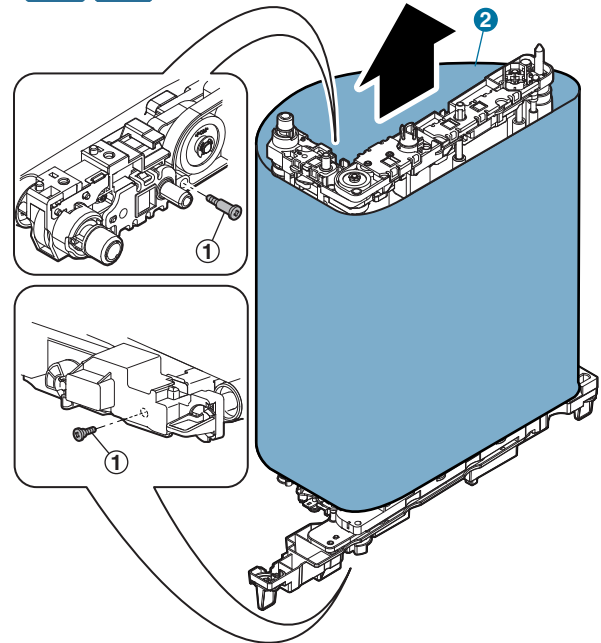

#### b. Secondary transfer drive transmission gear

- 1) Clean the secondary transfer driver transmission gear.

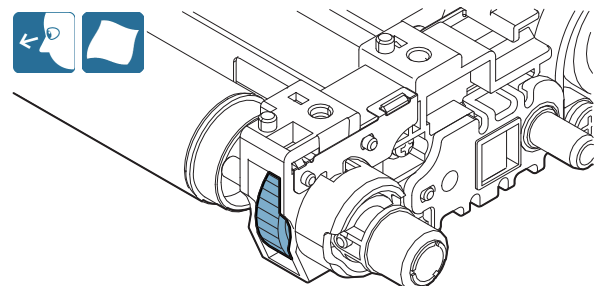

**c. Primary transfer belt drive roller, Primary transfer belt follower roller**

- 1) Clean the primary transfer belt drive roller, and the primary transfer belt follower roller.

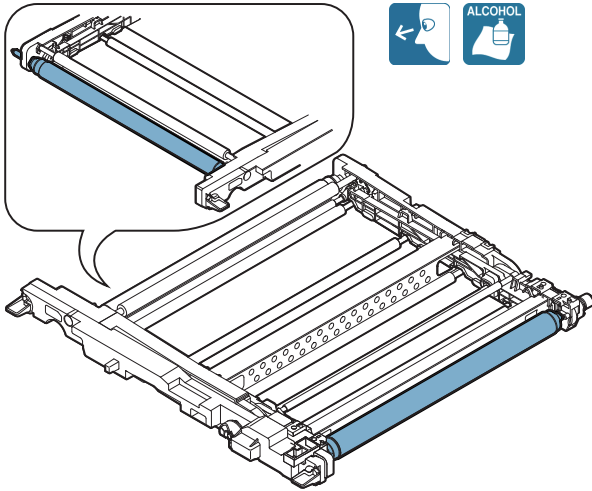

**d. Primary transfer belt tension roller, Registration backup roller**

- 1) Clean the primary transfer belt tension roller, registration backup roller.

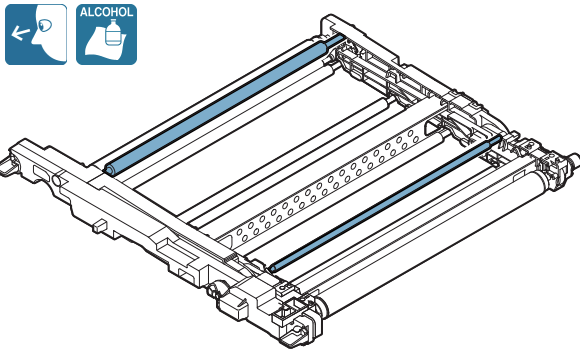

**e. Y auxiliary roller, PTC backup roller**

- 1) Clean the Y auxiliary roller, and the PTC backup roller.

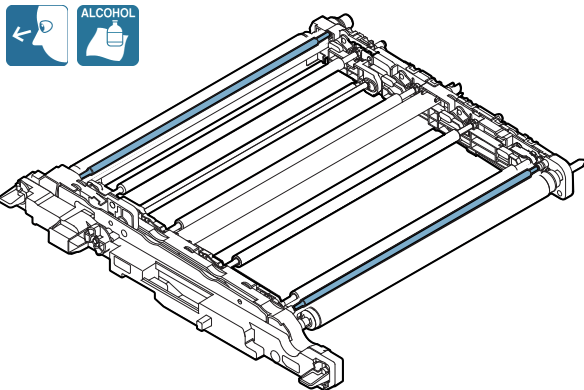

**f. Primary transfer roller**

- 1) With the front section of the primary transfer unit slightly lifted, rotate the transfer lock cam knob counterclockwise so that it is at the angle shown in the figure.

With the above procedure, the primary transfer roller may be removed.

**Important**

Be sure to slightly lift the front section of the primary transfer unit when rotating the transfer lock cam knob. If not, a stress is applied to the standard reflection plate lever, causing a trouble.

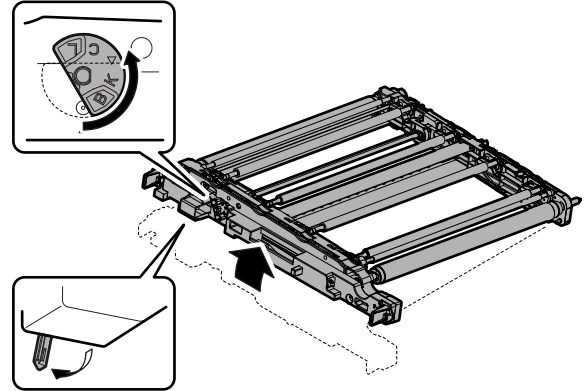

- 2) Release the lock of the bearing, and remove the bearing and the primary transfer roller.

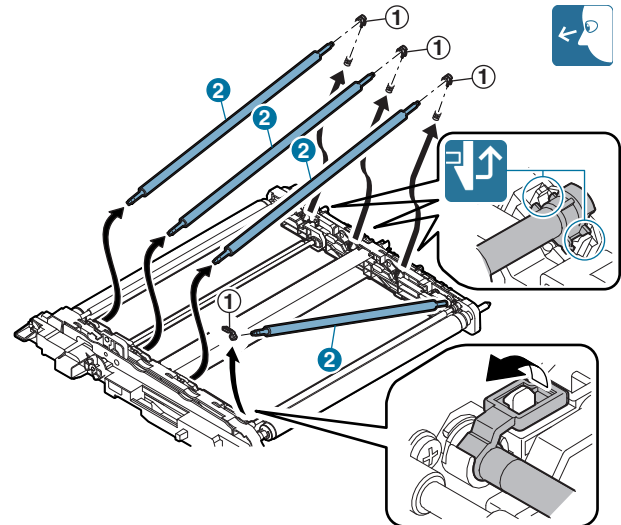

- 3) With the front section of the primary transfer unit slightly lifted, return the transfer lock cam knob to the neutral angle.



## (2) Primary transfer cleaner unit

No.	Name
1	Transfer cleaner seal F/R
2	Primary transfer belt cleaner blade
3	Primary transfer toner reception blade

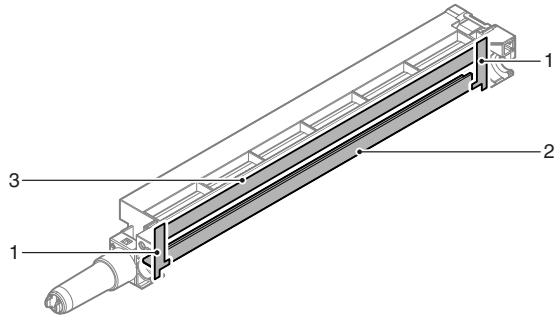

### a. Transfer cleaner seal F/R

- 1) Remove the transfer cleaner seal F/R.

**Important**

When replacing the transfer cleaner seals R/F, attach a new seal to the reference.

Thoroughly clean the frame surface of any old glue residue before attaching the new seals.

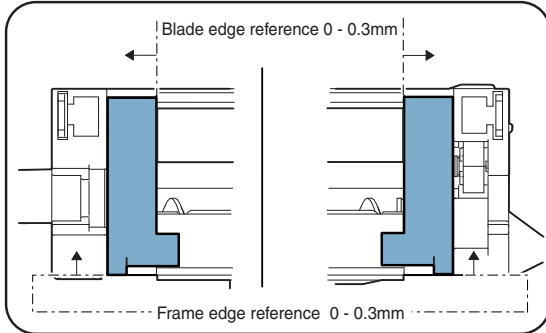
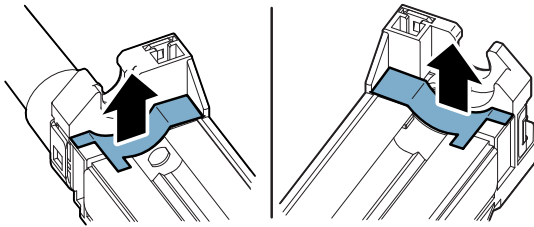

### b. Primary transfer belt cleaner blade

- 1) Remove the primary transfer belt cleaner blade.

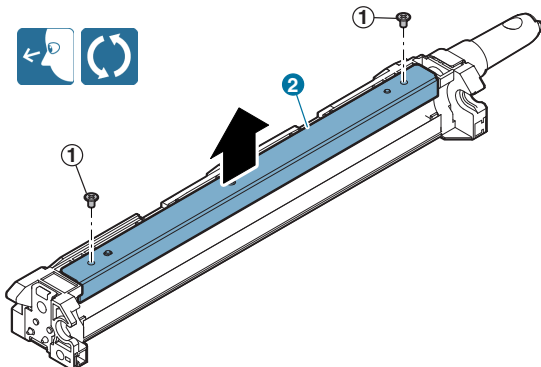

### c. Primary transfer toner reception blade

- 1) Remove the primary transfer toner reception blade.

**Important**

When replacing the primary transfer toner reception blade, attach a new one to the reference.

Thoroughly clean the frame surface of any old glue residue before attaching the new seals.

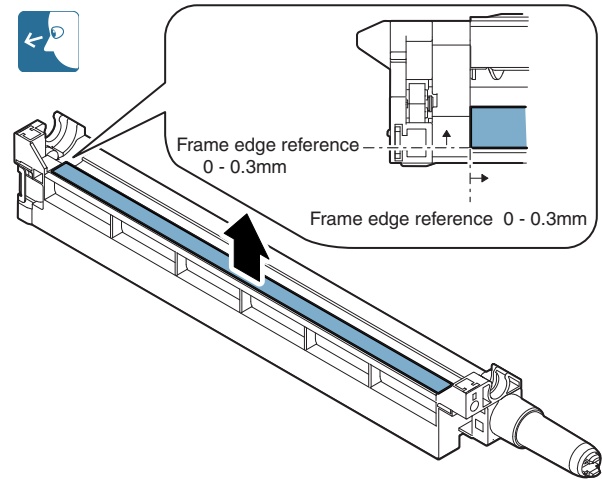

**Important**

After replacement of the primary transfer belt, perform the following procedures.

- 1) With the primary transfer cleaner unit removed, apply starting powder (UKOG-0123FCZZ) to the whole surface of the primary transfer belt.

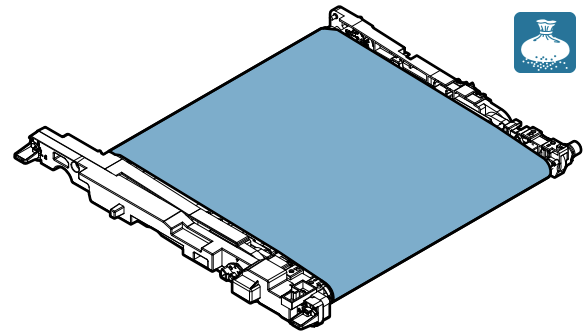

- 2) Attach the primary transfer cleaner unit.
- 3) Manually rotate the transfer belt drive gear to remove starting powder from the primary transfer belt clearly.

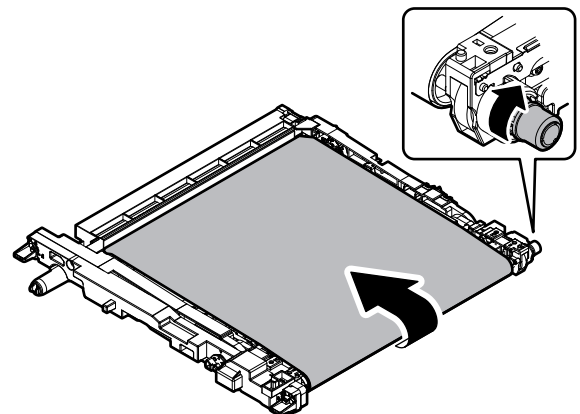

### (3) Secondary transfer unit

No.	Name
1	Secondary transfer belt follower roller
2	Secondary transfer belt
3	Secondary transfer belt drive roller
4	Secondary transfer backup roller
5	Secondary transfer belt tension roller
6	Secondary transfer roller
7	Secondary transfer drive gear

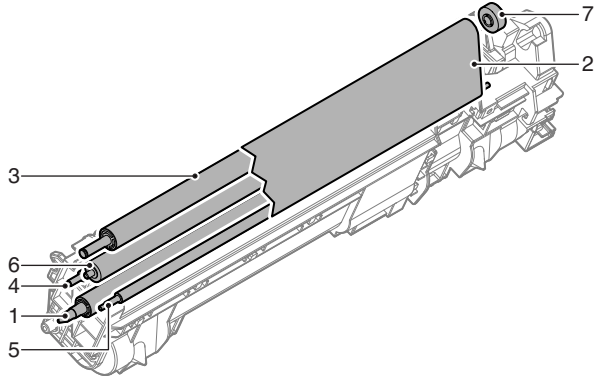

#### a. Secondary transfer belt follower roller, Secondary transfer belt

- 1) Remove the spring, and separate the secondary transfer belt unit and the secondary transfer base unit.

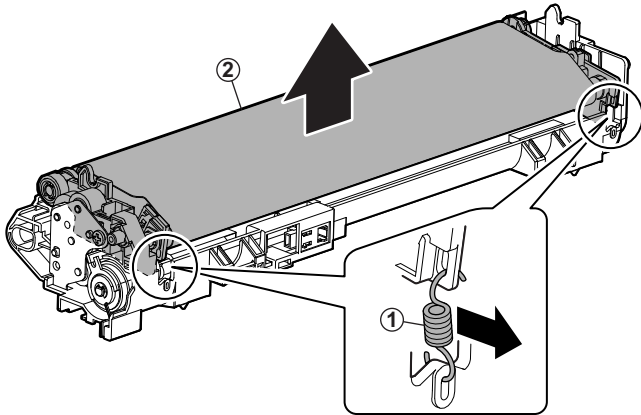

#### Important

Before assembling the secondary transfer belt unit and the secondary transfer base unit, apply grease (HANAL FL-955R) to the cam and the frame of the secondary transfer base unit.

\* Use care not to apply grease to the secondary transfer belt.

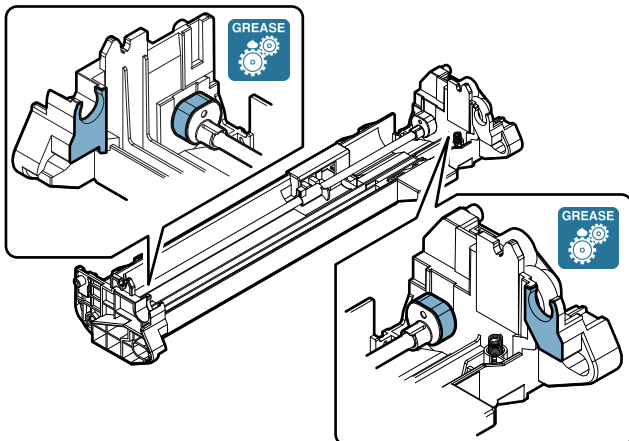

- 2) Remove the holder, and remove the secondary transfer belt follower roller. Clean the secondary transfer belt follower roller.

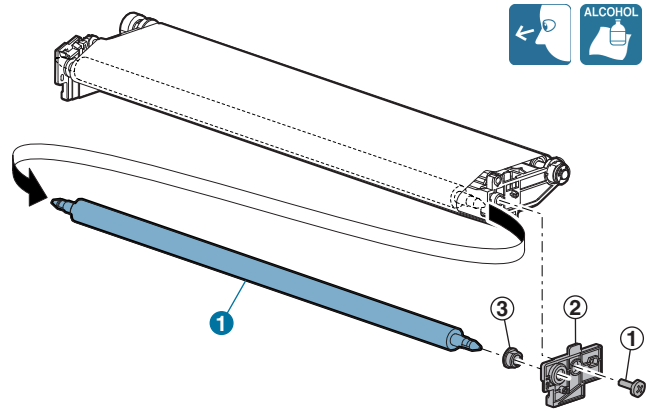

- 3) Remove the secondary transfer belt.

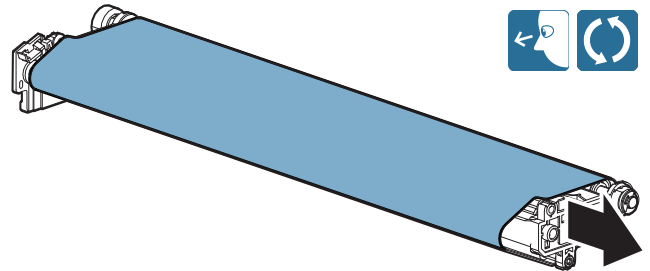

#### b. Secondary transfer belt drive roller, Secondary transfer backup roller, Secondary transfer belt tension roller

- 1) Clean the secondary transfer belt drive roller, the secondary transfer backup roller, and the secondary transfer belt tension roller.

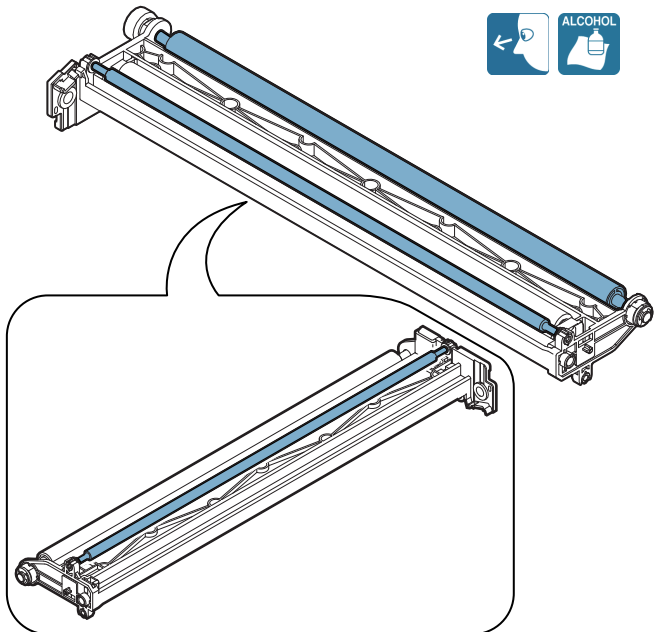

**c. Secondary transfer roller**

- 1) Remove the bearing, and remove the secondary transfer roller.

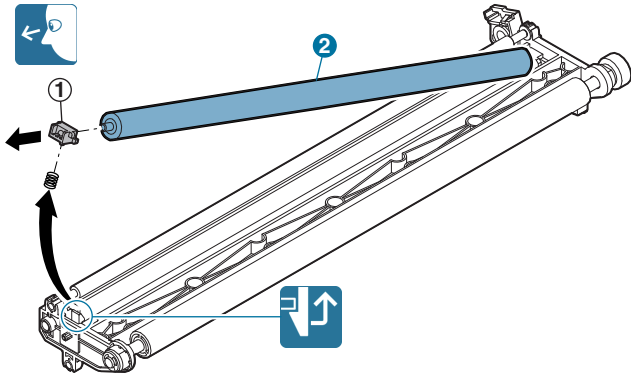

**d. Secondary transfer drive gear**

- 1) Remove the E-ring and the bearing. Slide the secondary transfer belt drive roller, and remove the parallel pin and the secondary transfer drive gear.

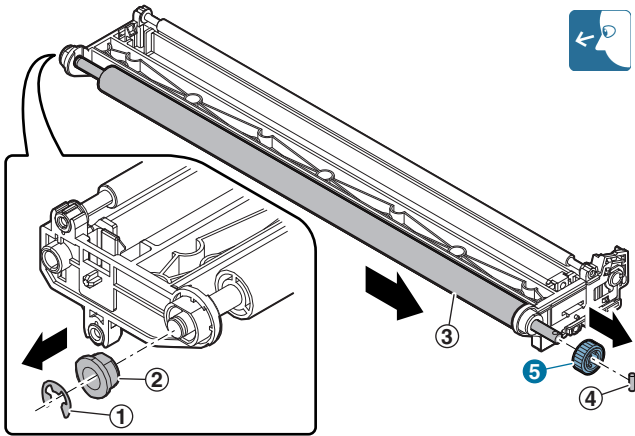

**(4) PTC unit**

No.	Name
1	PTC cleaner
2	PTC wire
3	PTC cleaner holder

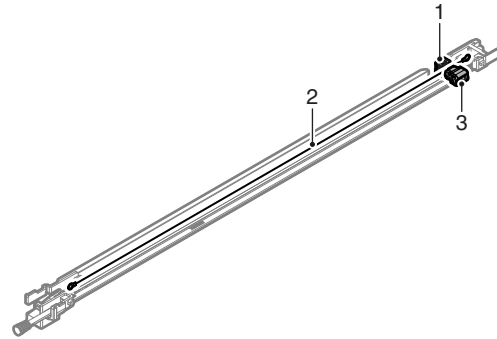

**a. PTC cleaner, PTC wire, PTC cleaner holder**

- 1) Remove the PTC cleaner.

**Important**

Check to confirm that the PTC wire is located at the center between the PTC cleaner holder and the PTC cleaner.

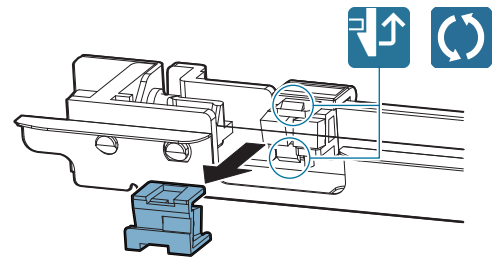

- 2) Remove the electrode plate, and remove the spring. Remove the electrode plate and the spring from the PTC wire.

**Important**

Do not touch the wire section of the PTC wire with bare hands.

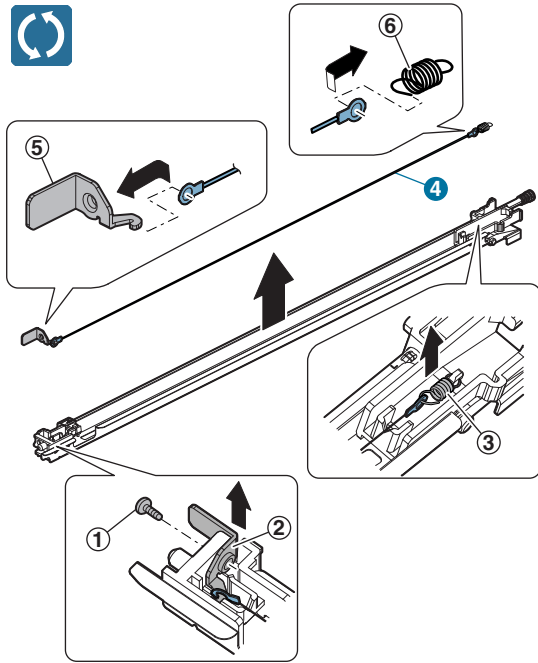

- 3) Remove the holder, and remove the PTC cleaner holder.

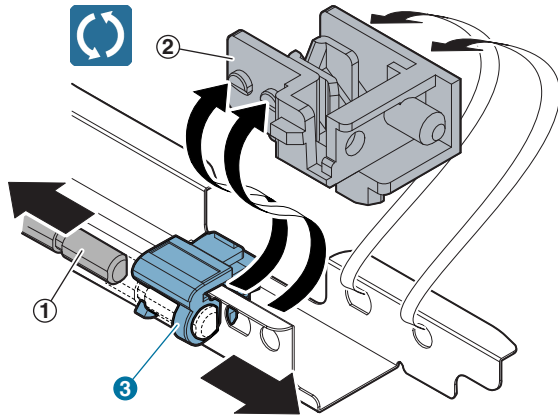

## G. LSU section

### (1) LSU

No.	Name
1	Dust-proof glass

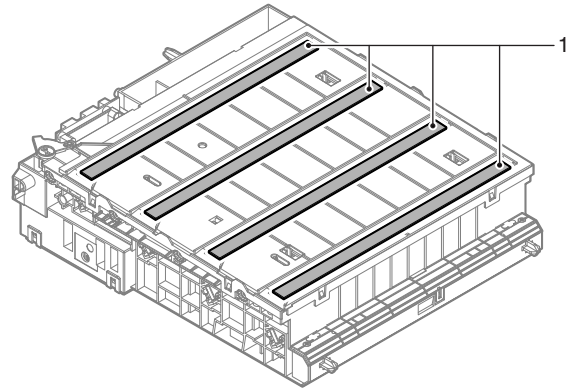

#### a. Dust-proof glass

- 1) Remove the waste toner box.
- 2) Remove the LSU cleaning rod from the front cabinet.

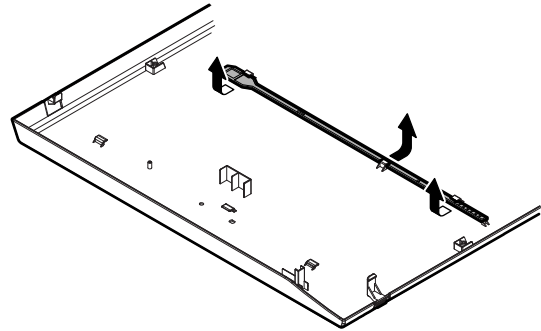

- 3) Insert the LSU cleaning rod with the felt side downward, and move it back and forth several times to clean the LSU dust-proof glass.

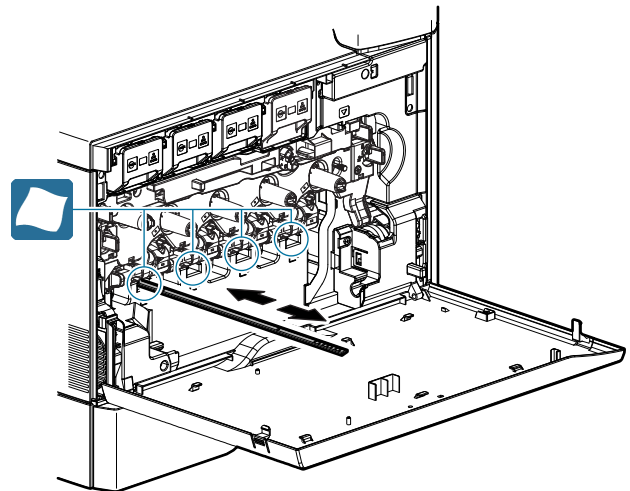

## (2) LSU cleaning rod

No.	Name
1	Cleaning base

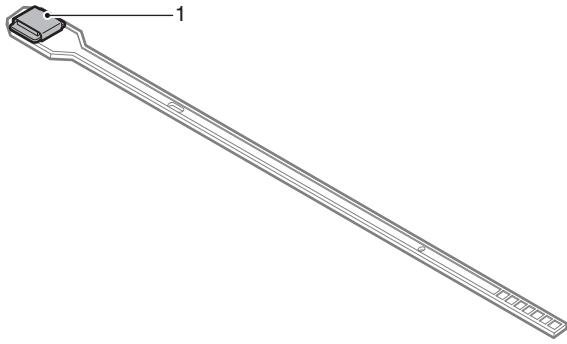

### a. Cleaning base

- 1) Remove the waste toner box.
- 2) Remove the LSU cleaning rod from the front cabinet.

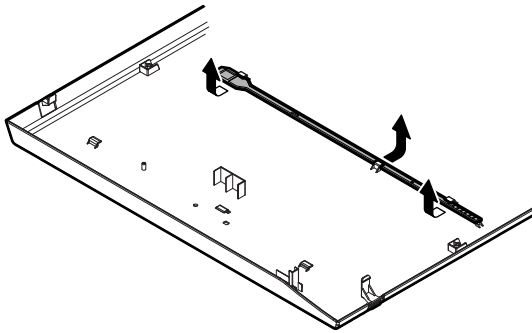

- 3) Remove the cleaning base from the waste toner box, and attach it to the LSU cleaning rod.

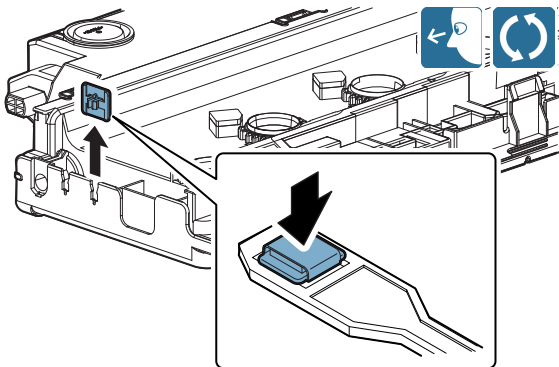

## H. Manual paper feed section

### (1) Manual paper feed unit

No.	Name
1	Paper feed roller
2	Separation roller
3	Torque limiter
4	Transport roller 9
5	Transport roller 10 (36cpm machine)

#### 18cpm/20cpm/23cpm/26cpm/31cpm machine

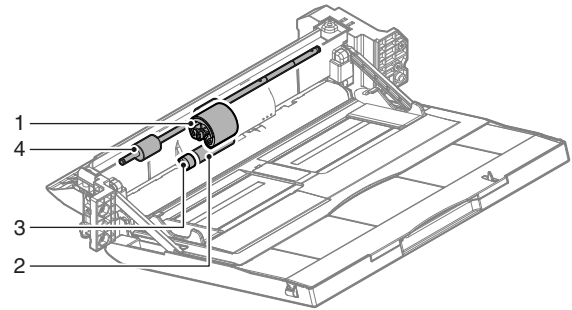

#### 36cpm machine

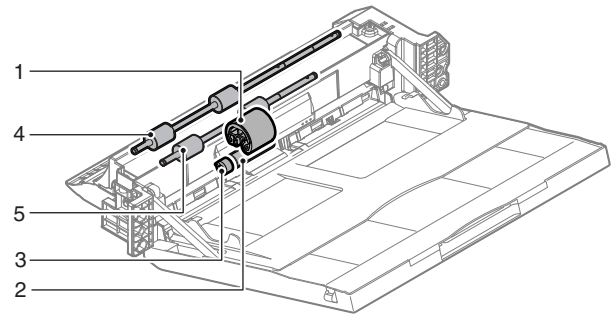

### a. Paper feed roller, Separation roller, Torque limiter

- 1) Remove the cover.

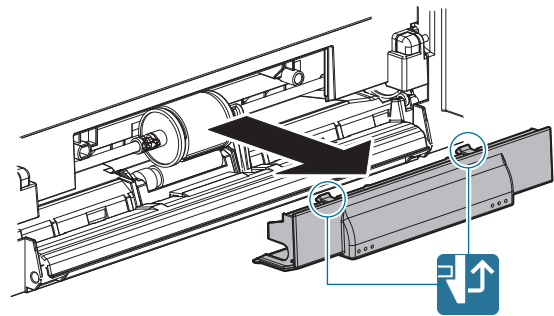

- 2) Slide the stopper and the collar, and remove the paper feed roller.

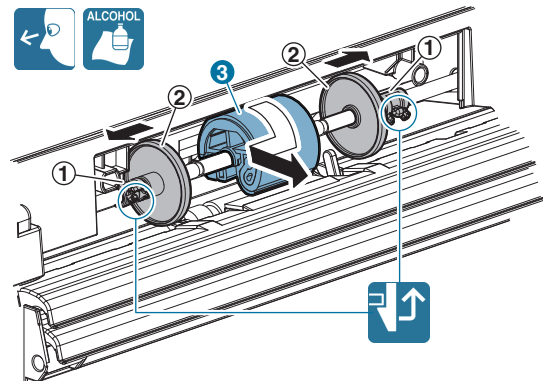

- 3) Remove the separation roller, and the torque limiter.

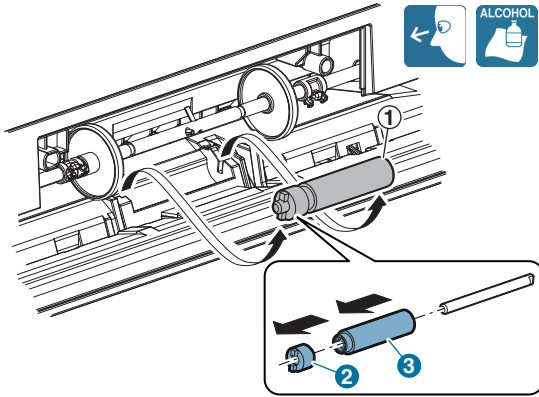

**b. Transport roller 9**

- 1) Clean the transport roller 9.

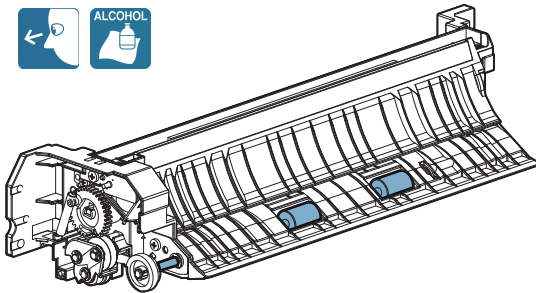

**c. Transport roller 10 (36cpm machine)**

- 1) Remove the paper guide, and clean the transport roller 10.

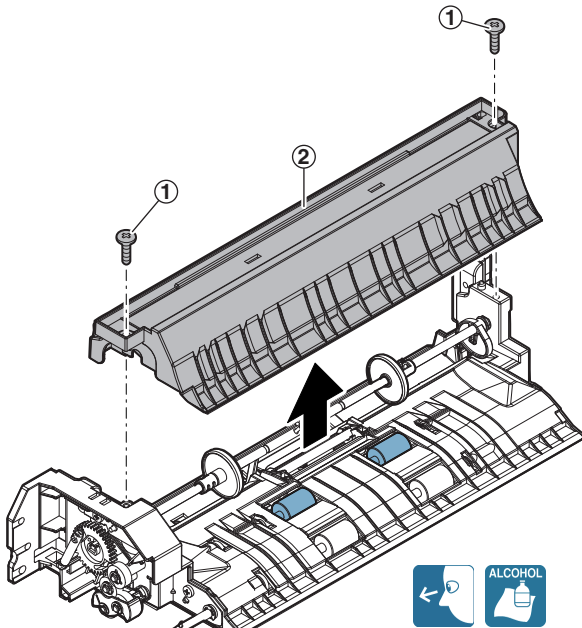

**I. Tray paper feed section**

**(1) Tray paper feed unit**

No.	Name
1	Paper pickup roller
2	Paper feed roller
3	Separation roller
4	Transport roller 4
5	Transport roller 2
6	Torque limiter

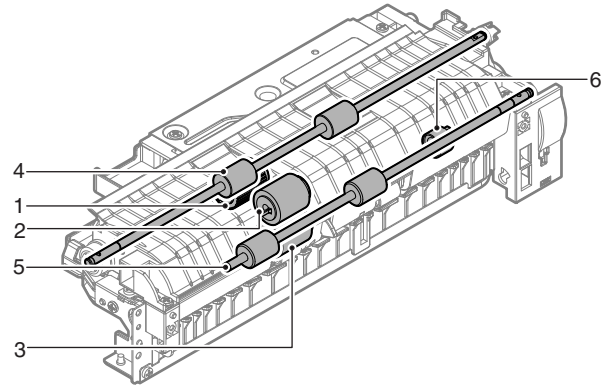

**a. Paper pickup roller, Paper feed roller, Separation roller**

- 1) Remove the paper feed tray.
- 2) Remove the paper guide.

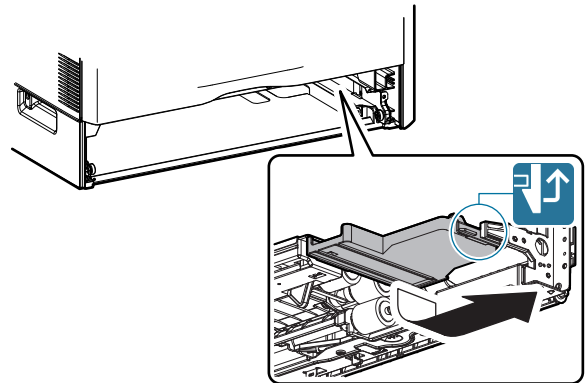

- 3) Remove the paper pickup roller, and the paper feed roller.

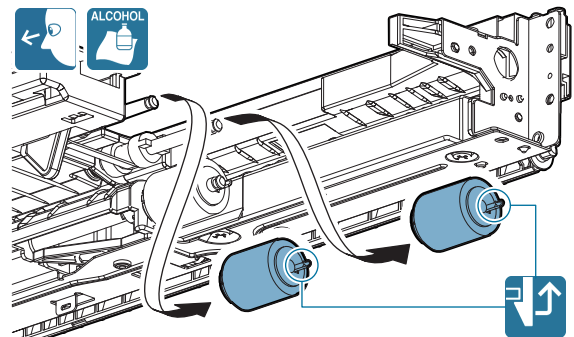

- 4) Remove the separation roller.

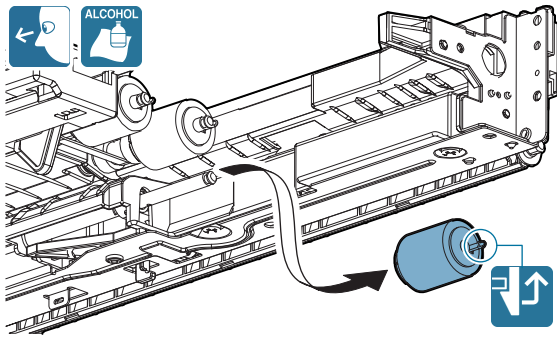

**b. Transport roller 4**

- 1) Clean the transport roller 4.  
18cpm/20cpm machine

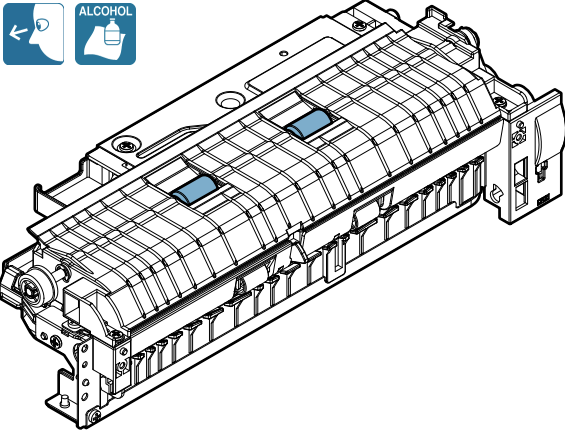

23cpm/26cpm/31cpm/36cpm machine

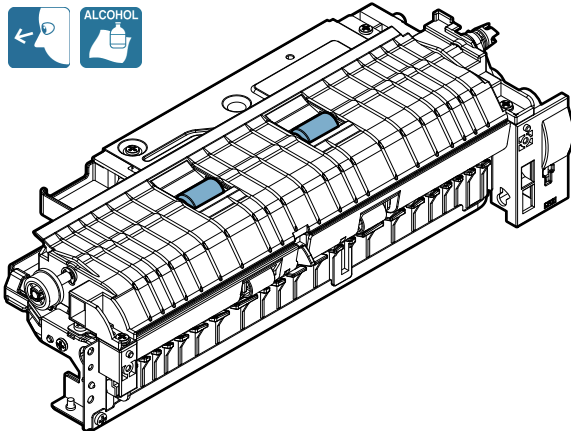

**c. Transport roller 2**

- 1) Remove the E-ring and the bearing, and remove the paper feed lower PG unit.

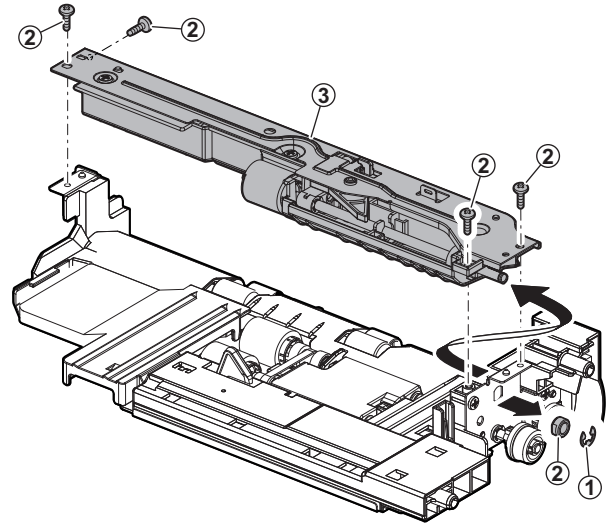

- 2) Clean the transport roller 2.

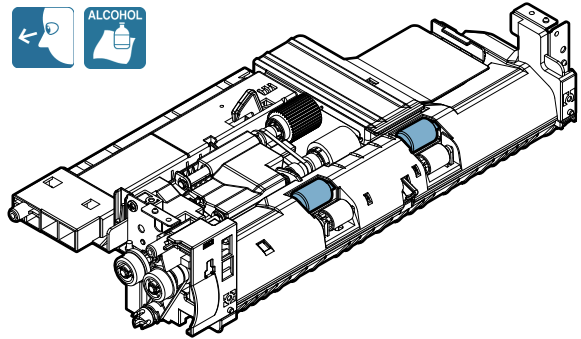

**d. Torque limiter**

- 1) Remove the E-ring and the bearing, and remove the paper feed lower PG unit.

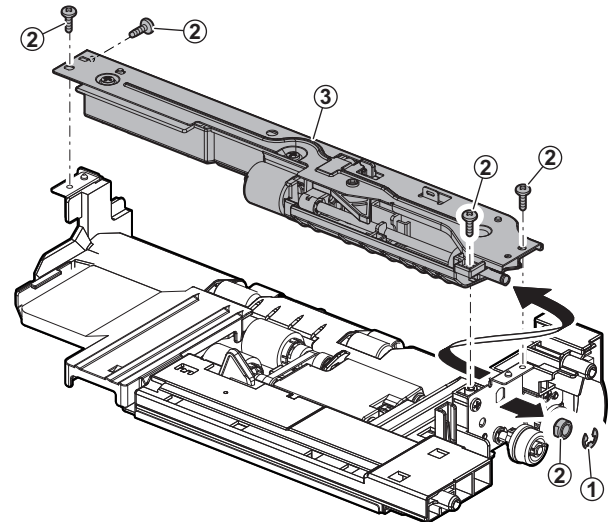

- Remove the spring, and remove the reinforcement plate. Remove the spring, and the separation pressure release plate.

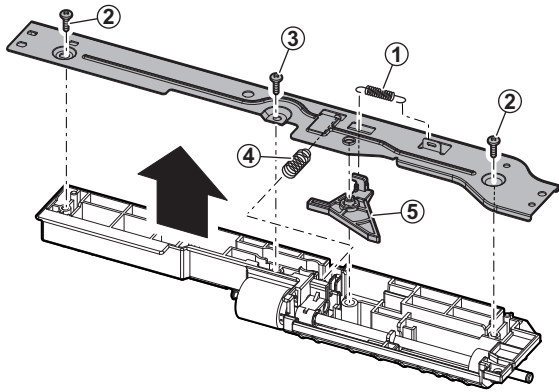

- Remove the separation roller. Remove the E-ring, and the shaft, and remove the torque limiter.

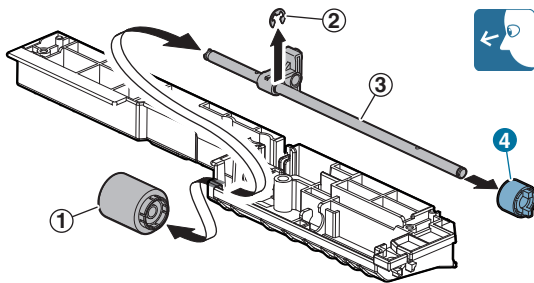

## J. Paper transport/Paper exit/ADU section

### (1) PS unit

No.	Name
1	Registration roller (Idle)
2	Registration roller (Drive)
3	Transport roller 5

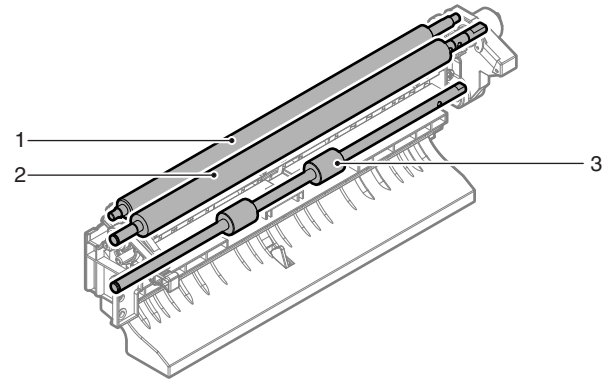

#### a. Registration roller (Idle), Registration roller (Drive), Transport roller 5

- Clean the registration roller (Idle), the registration roller (Drive), and the transport roller 5.

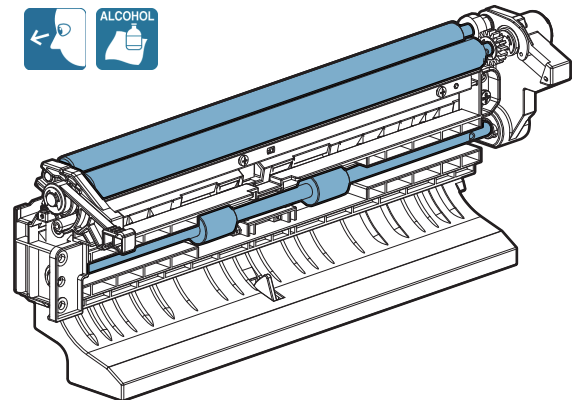



**(2) Right door unit  
(18cpm/20cpm/23cpm/26cpm/31cpm machine)**

No.	Name
1	Transport roller 7
2	Transport roller 8
3	Paper exit roller 2

18cpm machine

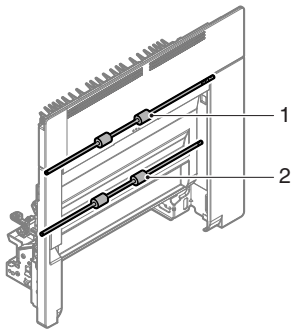

20cpm/23cpm/26cpm/  
31cpm machine

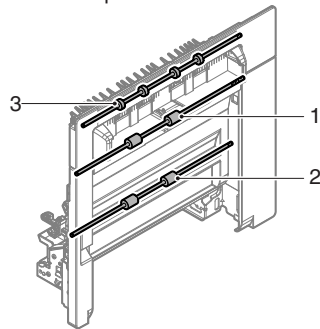

**(3) Right door unit (36cpm machine)**

No.	Name
1	Transport roller 7
2	Transport roller 8
3	Paper exit roller 3
4	Paper exit roller 2

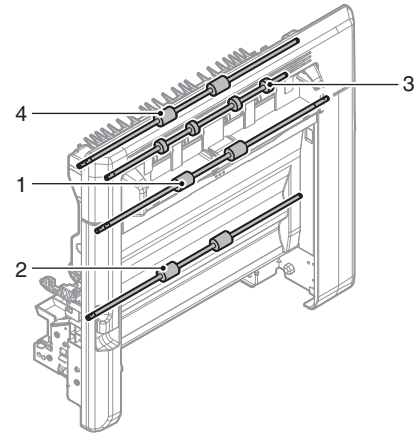

**a. Transport roller 7, Transport roller 8**

- 1) Open the ADU open/close door, and clean the transport roller 7, and the transport roller 8.

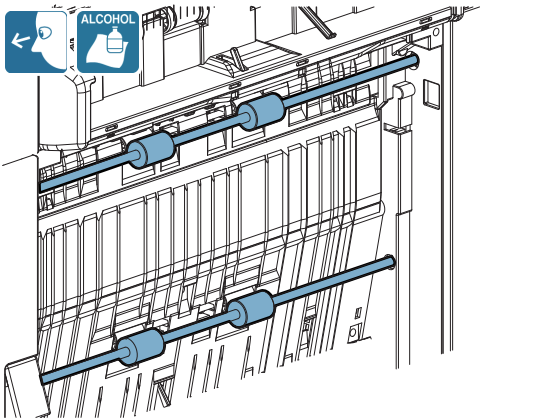

**a. Transport roller 7, Transport roller 8**

- 1) Open the ADU open/close door, and clean the transport roller 7, and the transport roller 8.

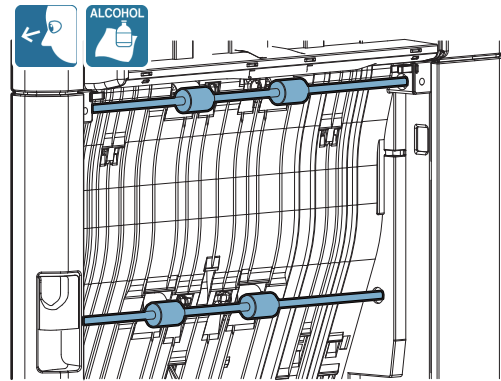

**b. Paper exit roller 2 (Except 18cpm machine)**

- 1) Open the right door unit, and clean the paper exit roller 2.

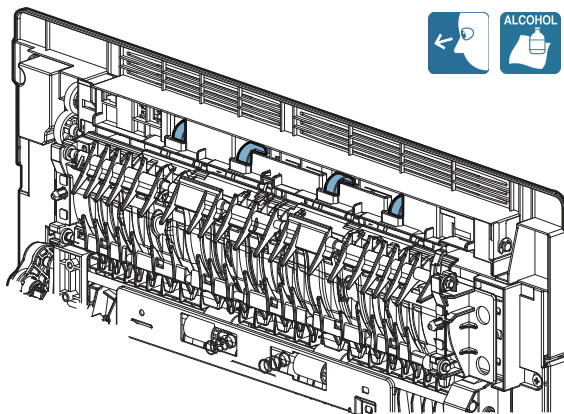

**b. Paper exit roller 3**

- 1) Open the right door unit, and clean the paper exit roller 3.

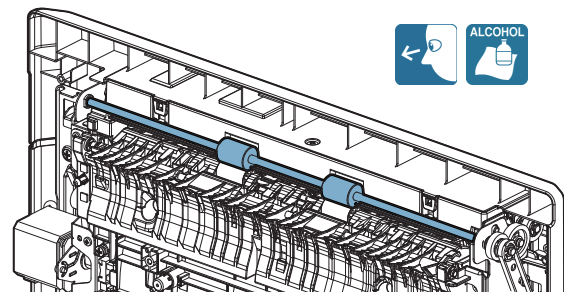

**c. Paper exit roller 2**

- 1) Open the right door unit, and remove the cover.

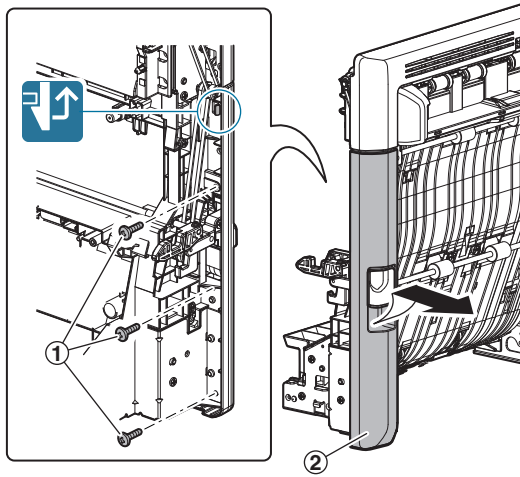

- 2) Remove the cover.

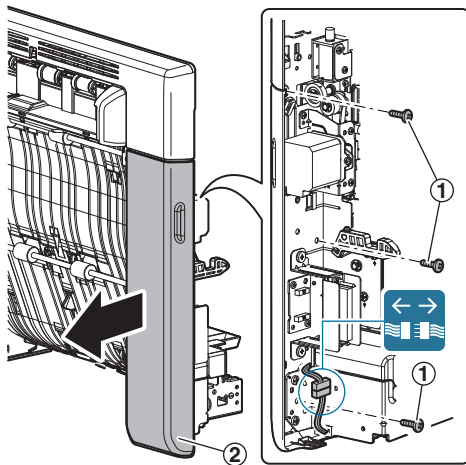

- 3) Remove the cover, and clean the paper exit roller 2.

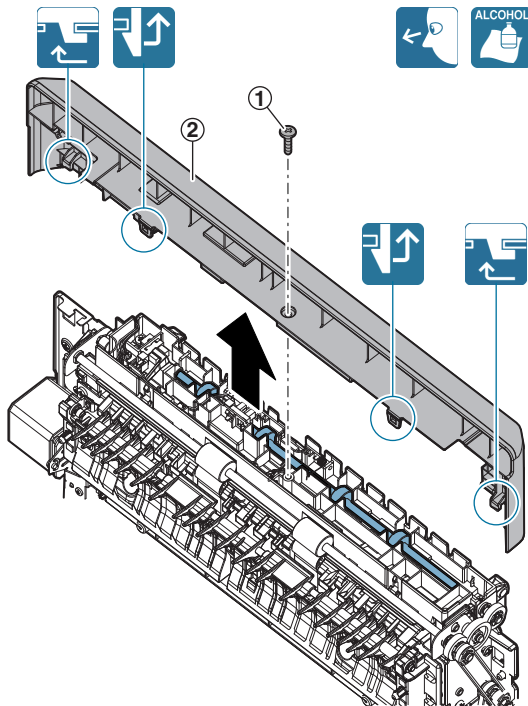

**(4) Fusing rear unit  
(18cpm/20cpm/23cpm/26cpm/31cpm machine)**

No.	Name
1	Transport roller 6

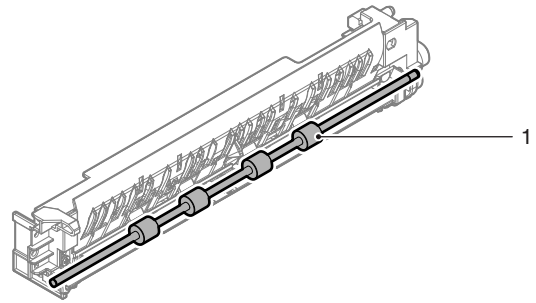

**a. Transport roller 6**

- 1) Clean the transport roller 6.

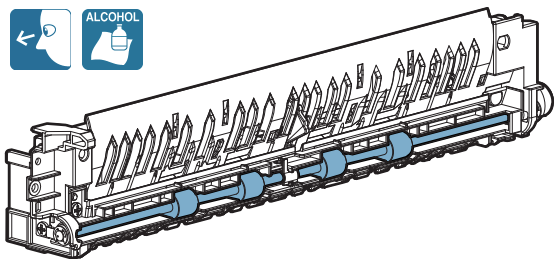

**(5) Paper exit unit**

No.	Name
1	Paper exit roller 1
2	Discharge brush

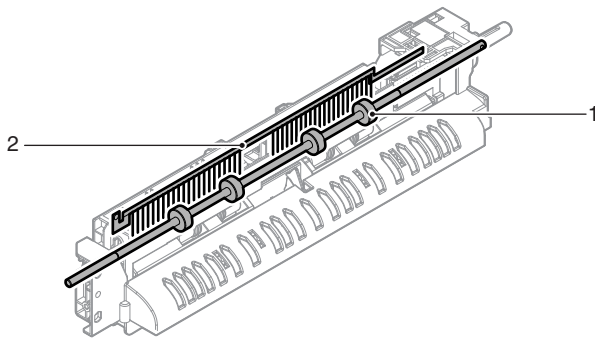

**a. Paper exit roller 1**

- 1) Clean the paper exit roller 1.

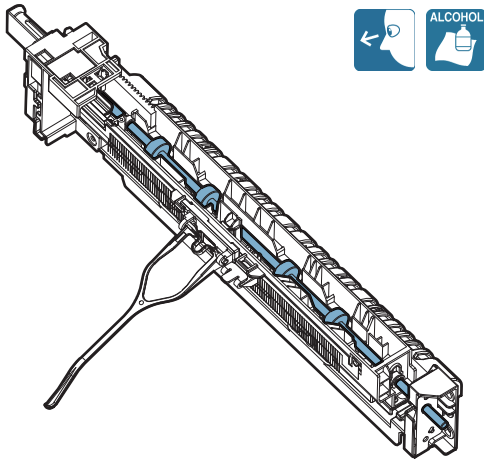

**b. Discharge brush**

- 1) Remove the holder.

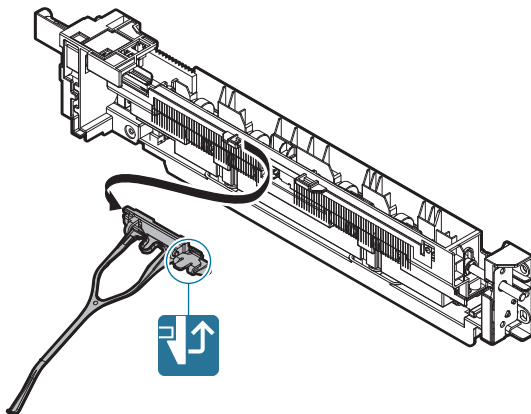

- 2) Remove the earth plate. Remove the discharge brush.

**Important**

When replacing the discharge brush, attach a new brush to the reference.

**Important**

Thoroughly clean the frame surface of any old glue residue before attaching the new seals.

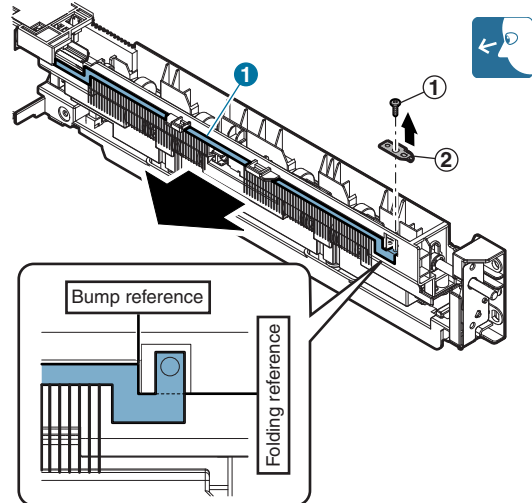

## K. Fusing section

### (1) Fusing unit (18cpm/20cpm machine)

No.	Name
1	Lower separation pawl
2	Lower separation pawl spring
3	Separation plate
4	Oil applying roller
5	Backup roller
6	CL roller bearing
7	Lower scraper assembly
8	Lower thermistor
9	Pressure roller gear
10	Pressure roller gear bearing
11	Pressure roller
12	Sub thermistor
13	Insulation bush
14	Heating roller bearing
15	Heating roller

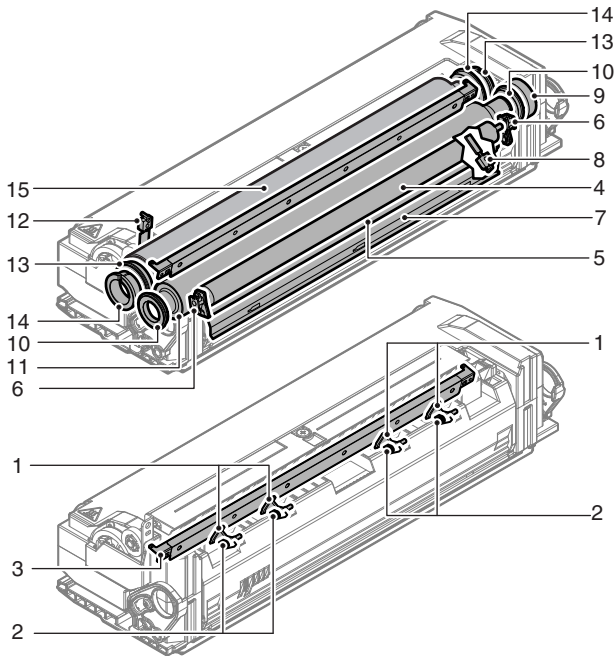

#### a. Lower separation pawl, Lower separation pawl spring

1) Remove the fusing cover.

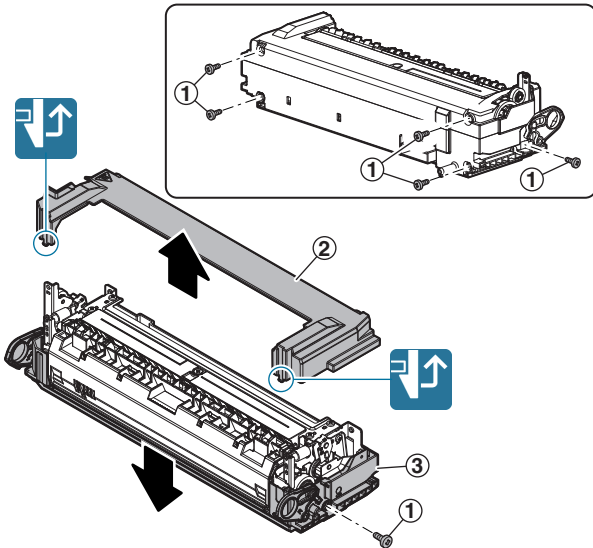

2) Remove the fusing rear lower PG unit.

**Important**

When removing, be careful not to lose the spring.

**Important**

When attaching, check to confirm that the spring hook is engaged.

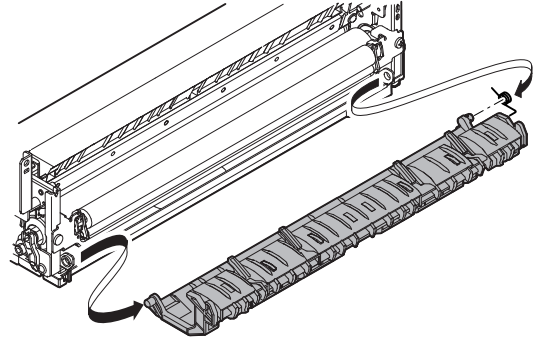

3) Remove the lower separation pawl and the lower separation pawl spring from the paper guide.

**Important**

When assembling, check to confirm that the hook of the lower separation pawl spring is engaged.

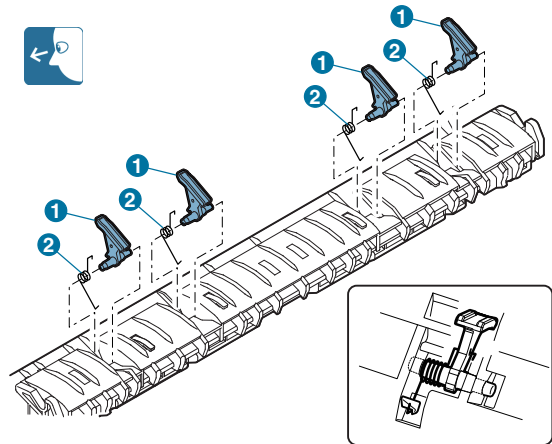

**Important**

When replacing the lower separation pawl, make the lower separation pawl tip touch the oil roller surface, and slightly brush the surface several times to apply oil to the pawl tip. Then install the separation pawl.

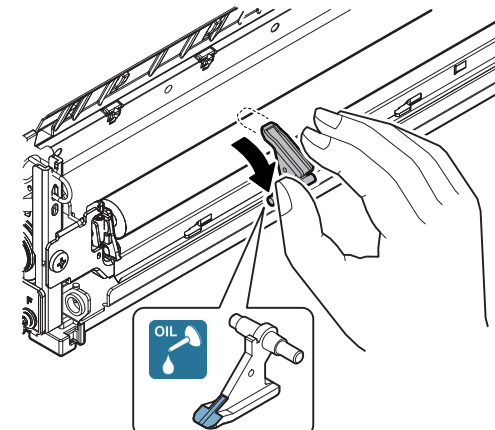

## b. Separation plate

- 1) Remove the paper guide.

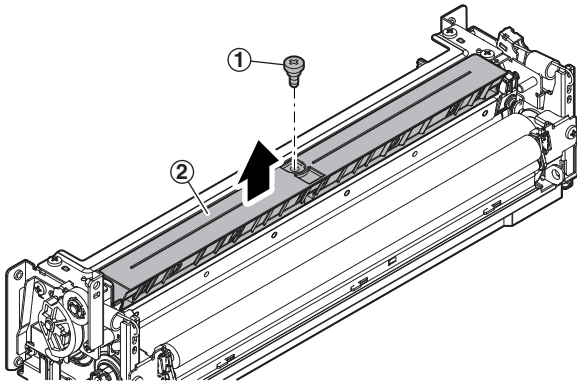

### Important

After installing the separation plate and the paper guide, manually move the separation plate to check the operation.

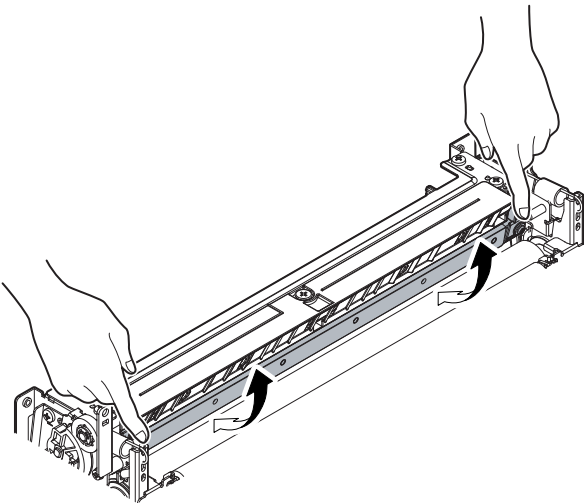

- 2) Remove the spring, and slide it to the front side, and remove the separation plate.

### Important

Be careful not to damage or scratch the separation plate surface.

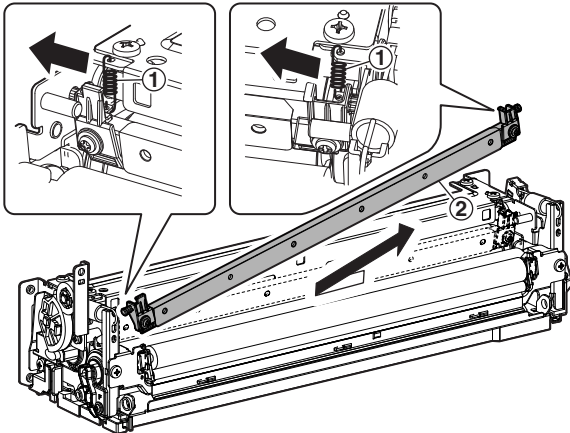

- 3) Remove the holder, from the separation plate.

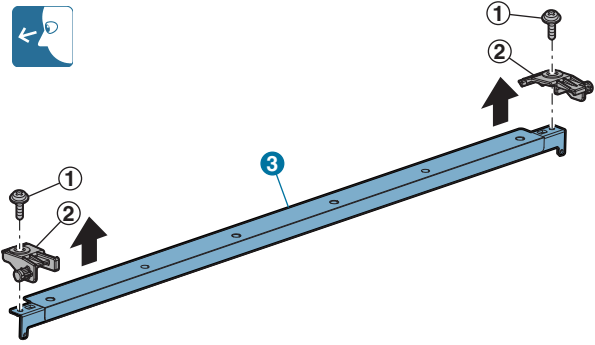

## c. Oil applying roller, Backup roller, CL roller shaft bearing, Lower scraper assembly

- 1) Remove the lower stay.

### Important

Since paper dust and toner remain in the lower scraper assembly, be careful not to disperse them in the unit when handling.

- Follower-type oil roller

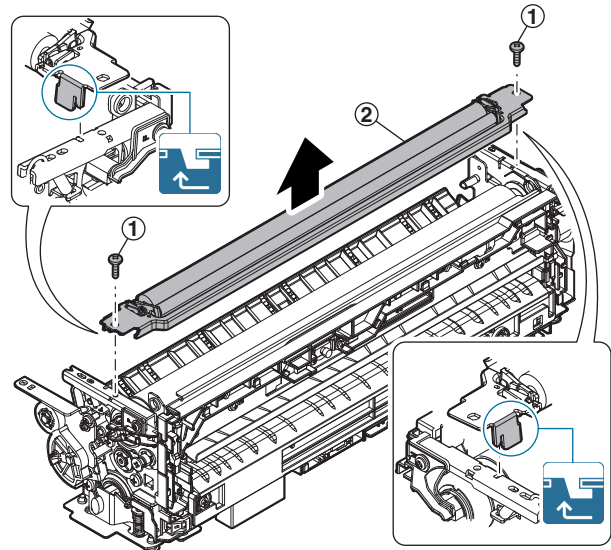

• Drive-type oil roller

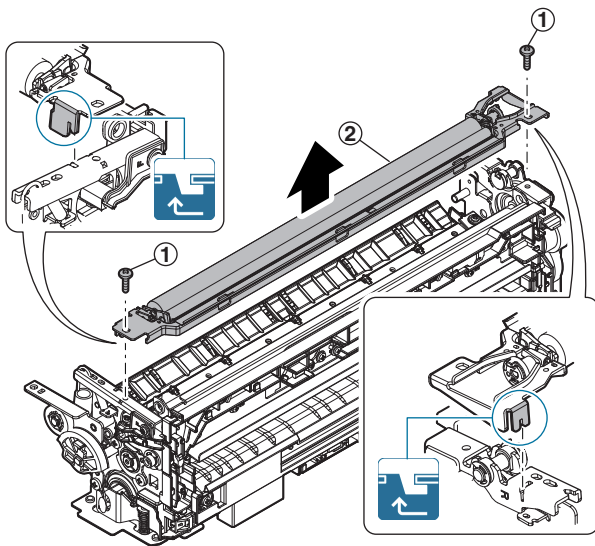

• Follower-type oil roller

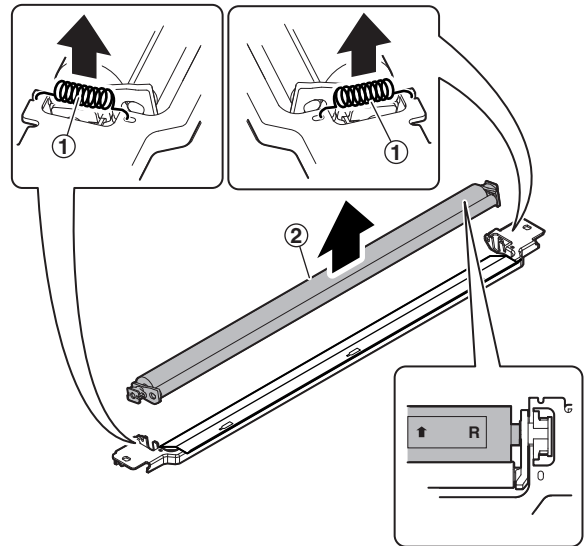

**Important**

When assembling the drive-type oil roller, fit the concave section of the shaft with the convex pawl of the coupling.

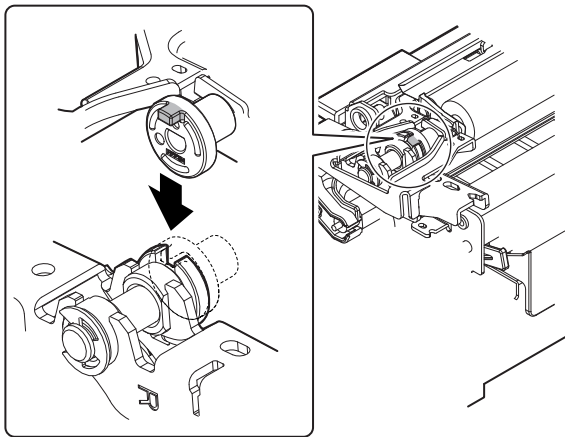

• Drive-type oil roller

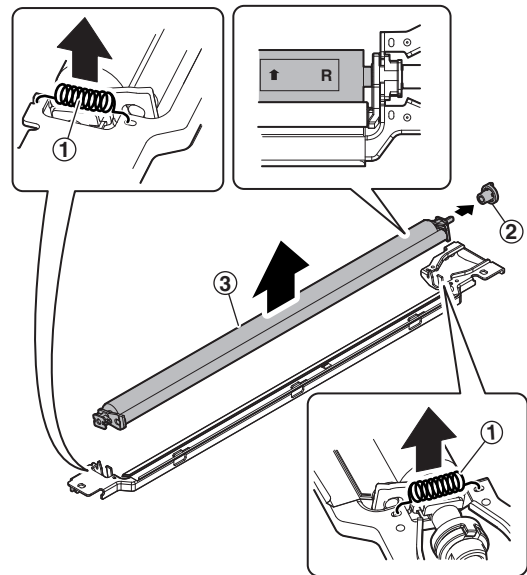

2) Remove the spring, and remove the oil applying roller unit.

**Important**

Place the lower stay so that the oil applying roller unit can be removed upward.

**Important**

When attaching the oil applying roller unit, check to confirm that "R" mark printed on the oil applying roller comes on the rear side.

3) Remove the CL roller bearing from the oil applying roller and the backup roller.

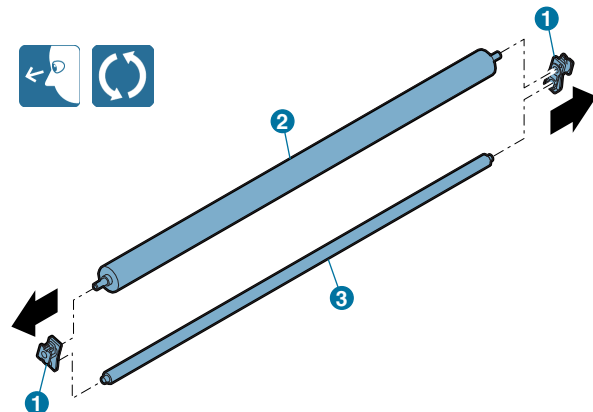

- 4) Remove the lower scraper assembly from the lower stay.

**Important**

Be careful not to deform the lower scraper assembly.

- Follower-type oil roller

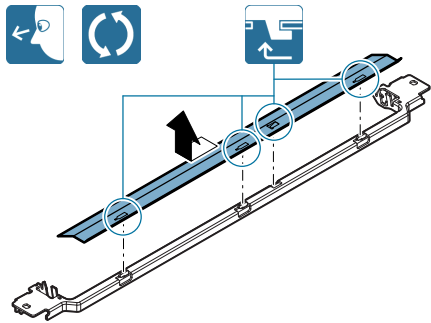

- Drive-type oil roller

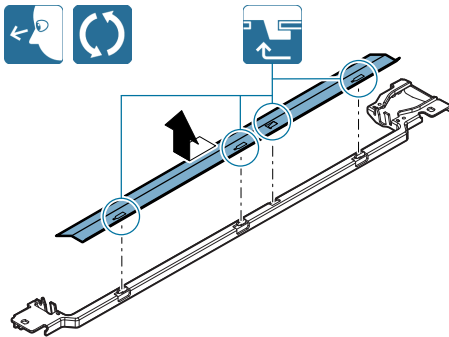

**d. Lower thermistor**

- 1) Remove the paper guide.

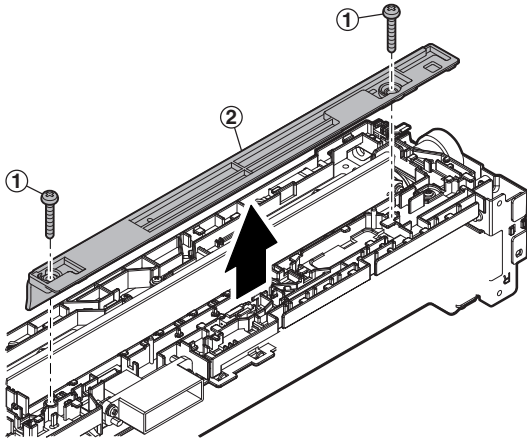

- 2) Disconnect the connector, and remove the mounting plate. Remove the lower thermistor from the mounting plate.

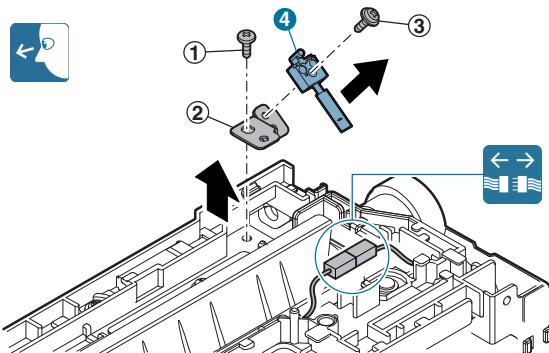

**e. Pressure roller gear, Pressure roller gear bearing, Pressure roller**

- 1) Remove the stay.
- Follower-type oil roller

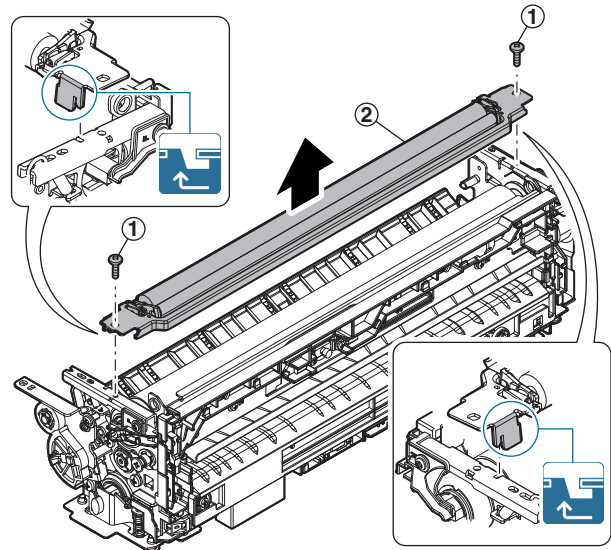

- Drive-type oil roller

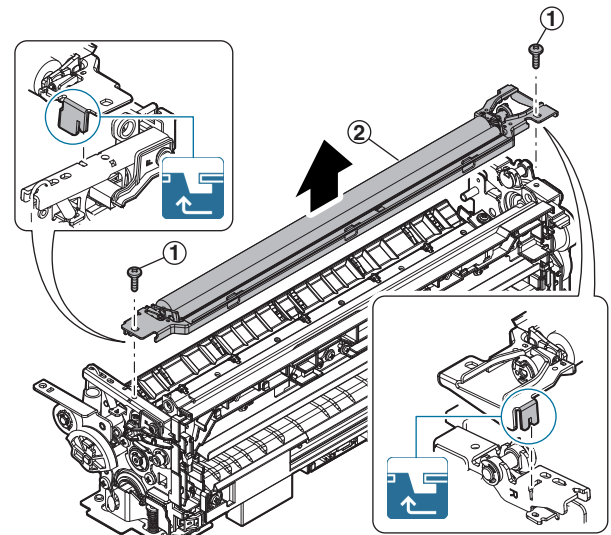

**Important**

When assembling the drive-type oil roller, fit the concave section of the shaft with the convex pawl of the coupling.

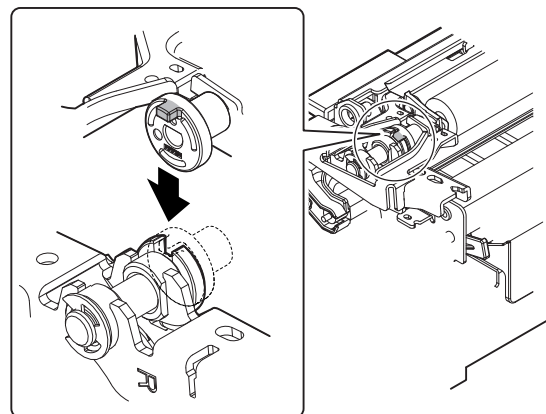

- 2) Remove the drive plate, and remove the gear.

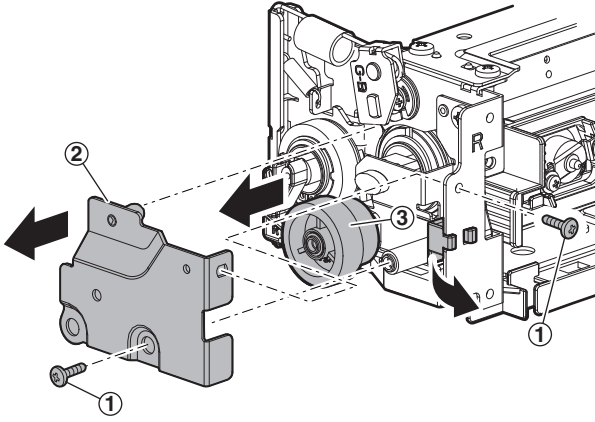

- 3) Disconnect the connector of the heater lamp. Remove the holder, and remove the heater lamp.

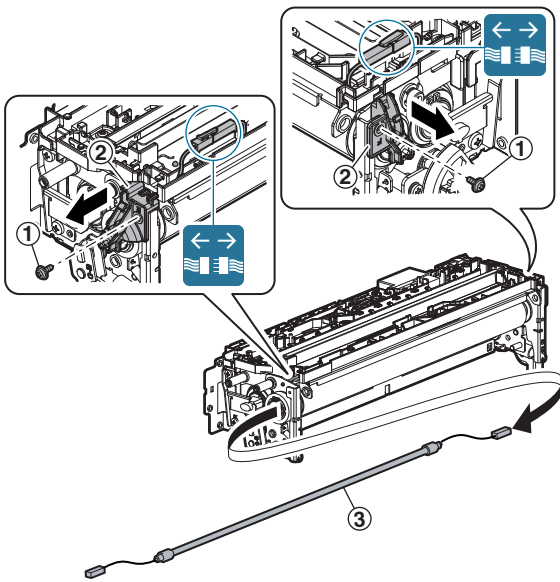

- 4) Remove the C-ring, the pressure roller gear, and the pressure roller gear bearing.

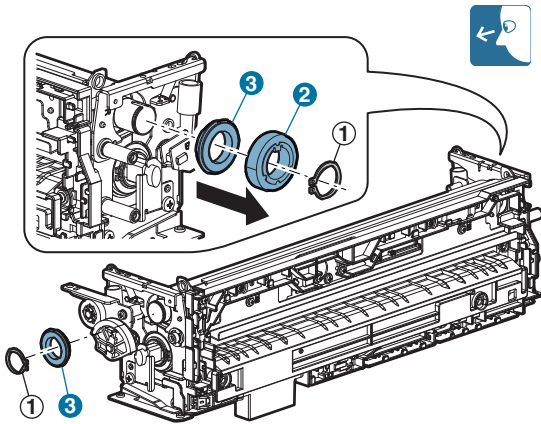

- 5) Remove the pressure roller.

**Important**

When attaching the pressure roller, attach it with the protection sheet on it. After completion of assembly, remove the protection sheet.

**Important**

When replacing the pressure roller, apply grease (JFE552). In addition, wipe the pressure roller surface with alcohol.

**Important**

For removal of the pressure roller, remove the lower thermistor then remove the roller.

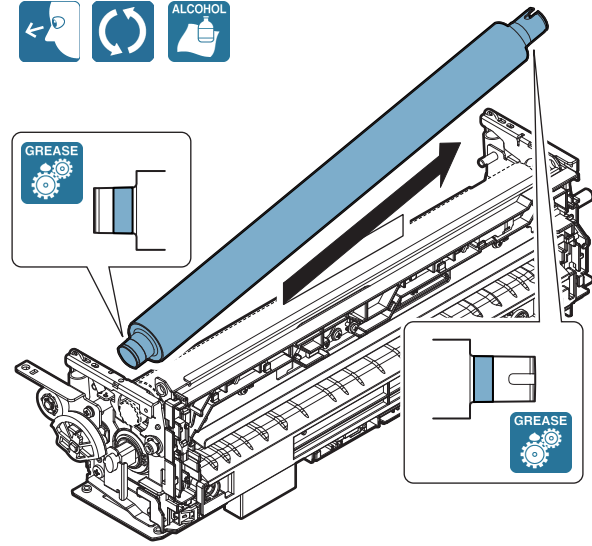

**f. Sub thermistor**

- 1) Disconnect the connector, and remove the sub thermistor.

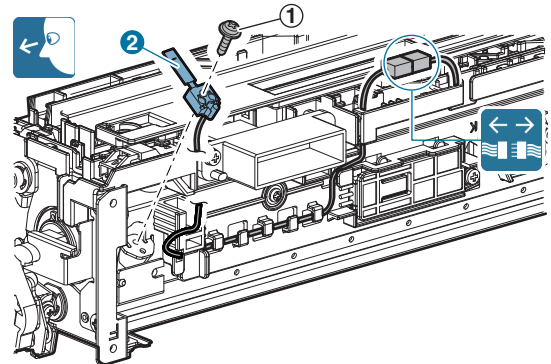



**g. Heat-insulating bush, heating roller bearing, heating roller**

- 1) Remove the paper guide. Disconnect the connector.

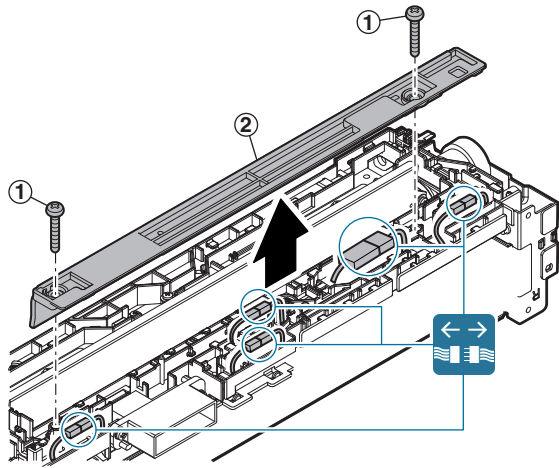

- 2) Remove the spring. Remove the holder, and remove the heater lamp.

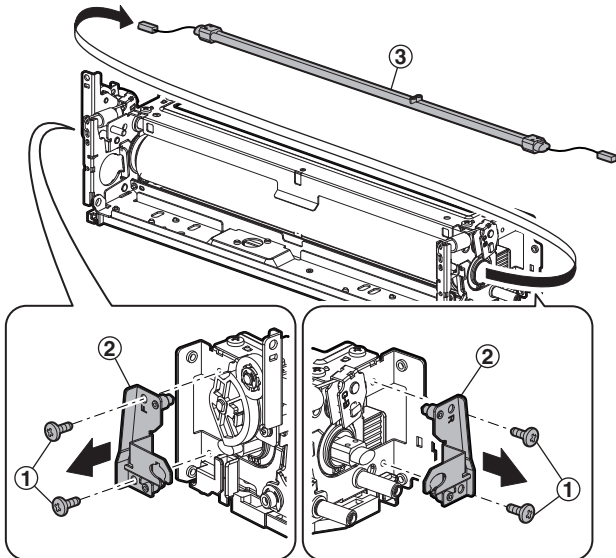

- 3) Remove the heating roller unit.

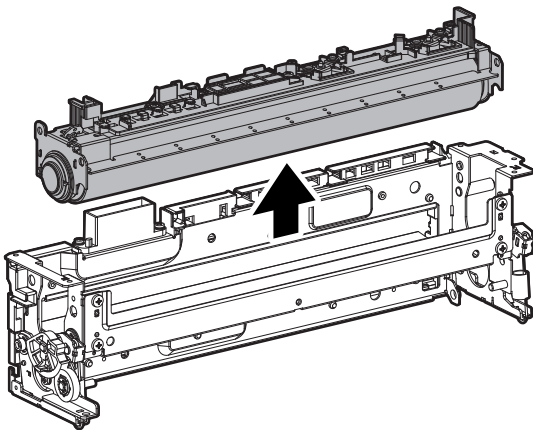

- 4) Remove the C-ring, the insulation bush, and the heating roller bearing. Remove the heating roller from the frame.

**Important**

When replacing the insulation bush, apply grease (JFE552) to the inner race and the outer race.

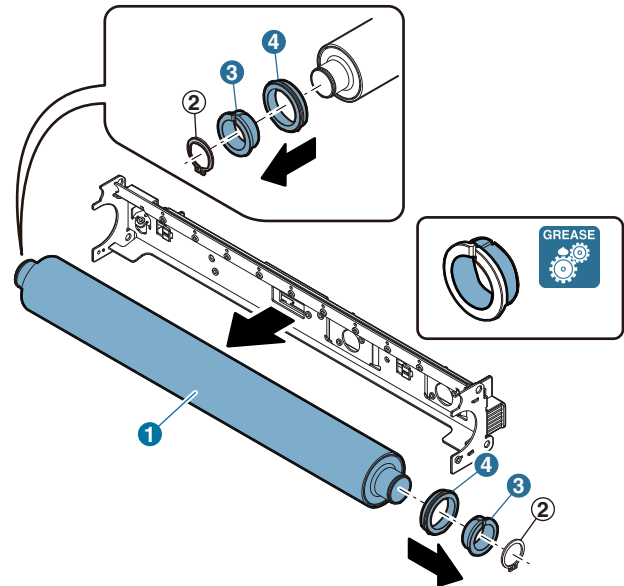

**(2) Fusing unit (23cpm/26cpm/31cpm machine)**

No.	Name
1	Lower separation pawl
2	Lower separation pawl spring
3	Separation plate
4	Oil applying roller
5	Backup roller
6	CL roller bearing
7	Lower scraper assembly
8	Lower thermistor
9	Pressure roller gear
10	Pressure roller gear bearing
11	Pressure roller
12	Sub thermistor
13	Fusing roller bearing
14	Insulation bush
15	Heating roller bearing
16	Meandering suppress collar
17	Fusing roller
18	Heating roller
19	Fusing belt
20	Washer

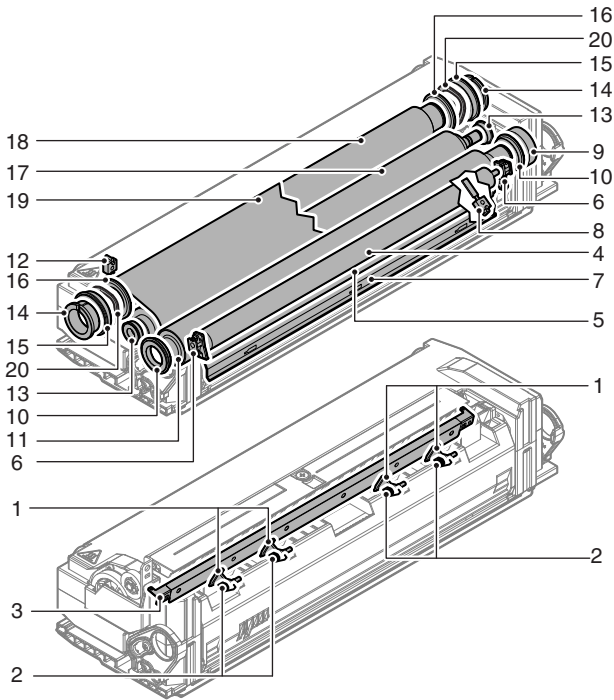

**a. Lower separation pawl, Lower separation pawl spring**

1) Remove the fusing cover.

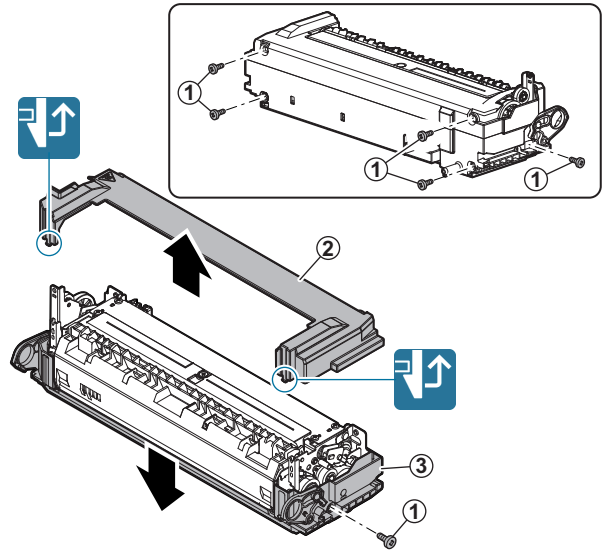

2) Remove the fusing rear lower PG unit.

**Important**

When removing, be careful not to lose the spring.

**Important**

When attaching, check to confirm that the spring hook is engaged.

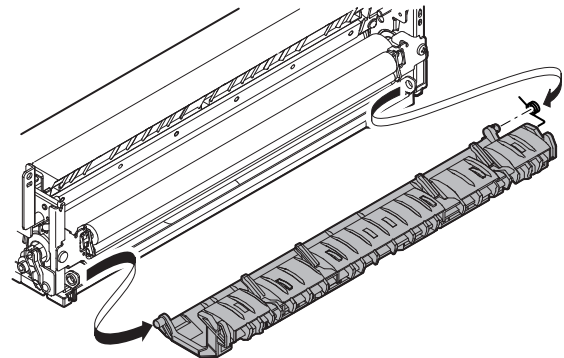

- 3) Remove the lower separation pawl and the lower separation pawl spring from the paper guide.

**Important**

When assembling, check to confirm that the hook of the lower separation pawl spring is engaged.

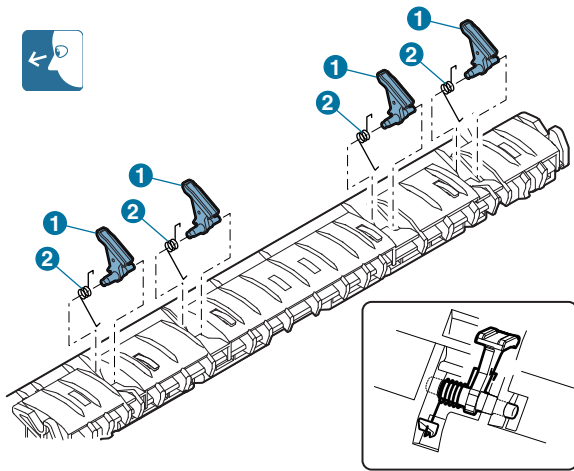

**Important**

When replacing the lower separation pawl, make the lower separation pawl tip touch the oil roller surface, and slightly brush the surface several times to apply oil to the pawl tip. Then install the separation pawl.

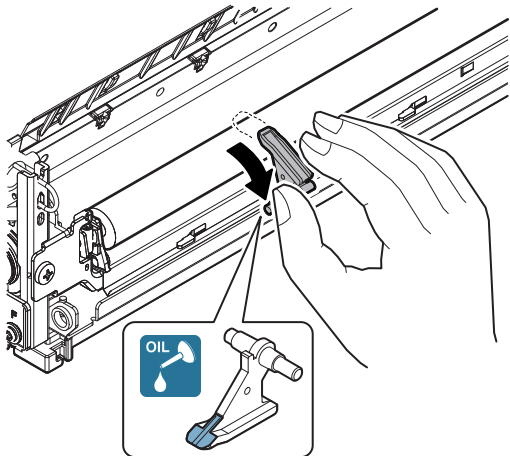

**b. Separation plate**

- 1) Remove the paper guide.

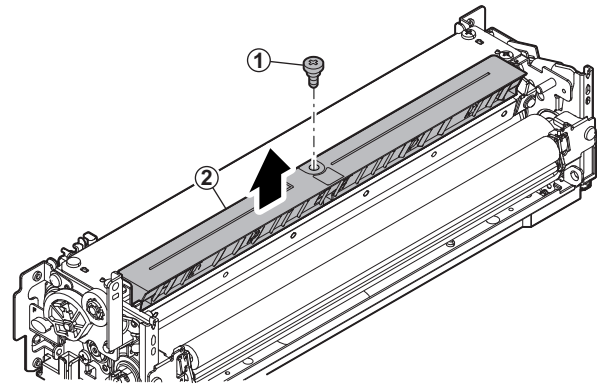

**Important**

After installing the separation plate and the paper guide, manually move the separation plate to check the operation.

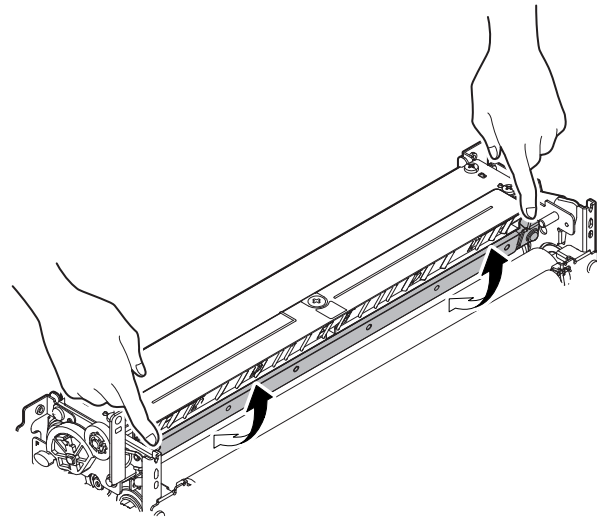

- 2) Remove the spring, and slide it to the front side, and remove the separation plate.

**Important**

Be careful not to damage or scratch the separation plate surface.

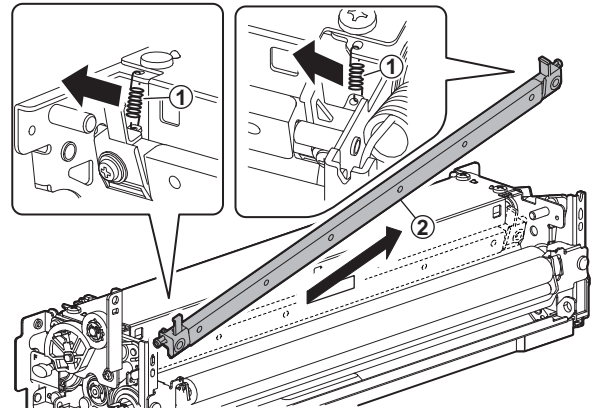

3) Remove the holder, from the separation plate.

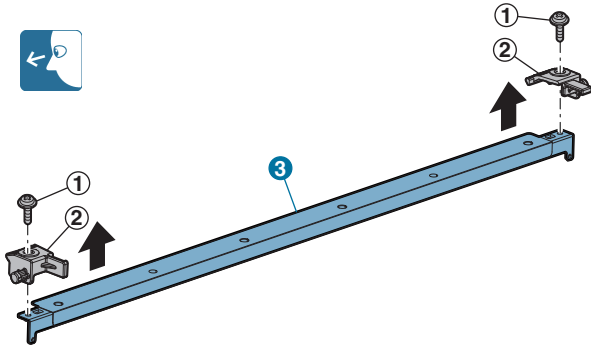

**c. Oil applying roller, Backup roller, CL roller shaft bearing, Lower scraper assembly**

1) Remove the lower stay.

**Important**

Since paper dust and toner remain in the lower scraper assembly, be careful not to disperse them in the unit when handling.

- Follower-type oil roller

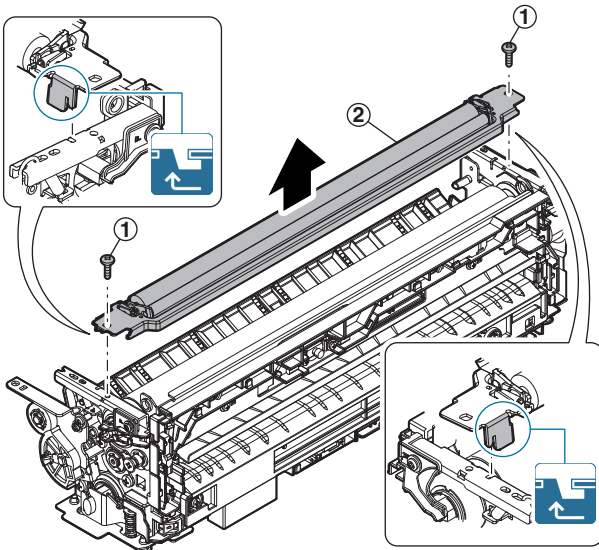

- Drive-type oil roller

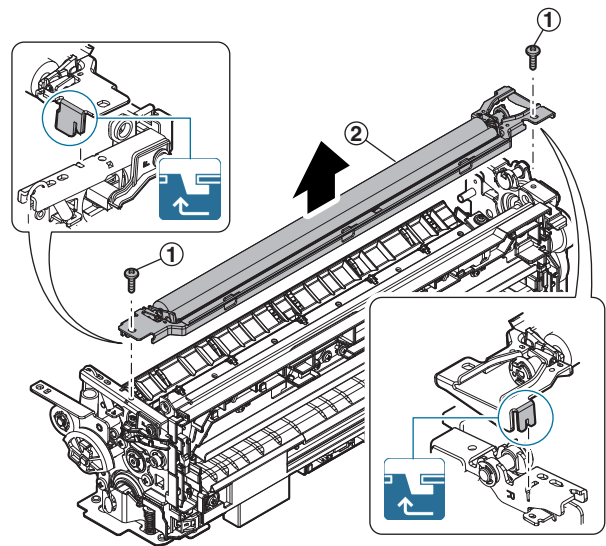

**Important**

When assembling the drive-type oil roller, fit the concave section of the shaft with the convex pawl of the coupling.

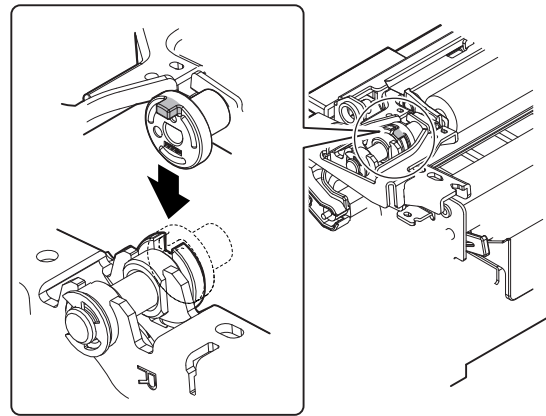

2) Remove the spring, and remove the oil applying roller unit.

**Important**

Place the lower stay so that the oil applying roller unit can be removed upward.

**Important**

When attaching the oil applying roller unit, check to confirm that "R" mark printed on the oil applying roller comes on the rear side.

- Follower-type oil roller

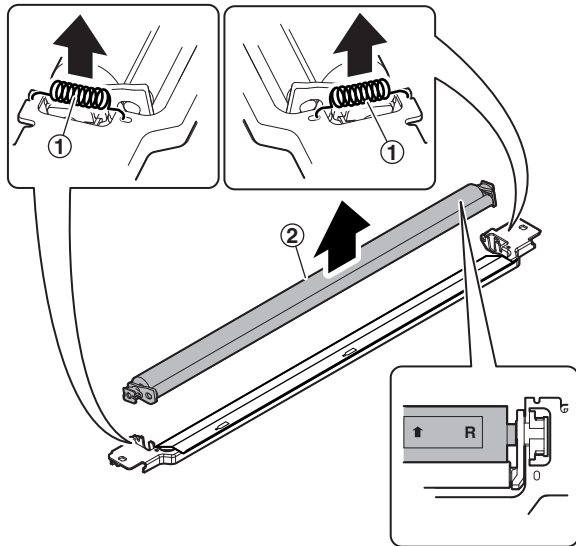

- Drive-type oil roller

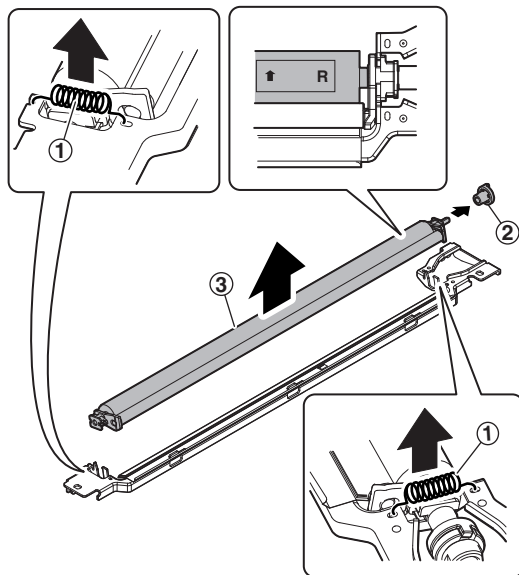

- 3) Remove the CL roller bearing from the oil applying roller and the backup roller.

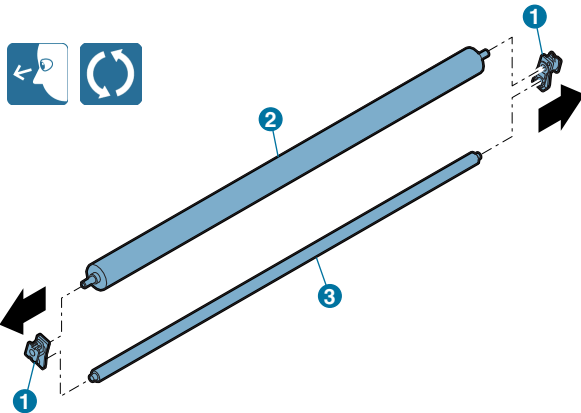

- 4) Remove the lower scraper assembly from the lower stay.

**Important**

Be careful not to deform the lower scraper assembly.

- Follower-type oil roller

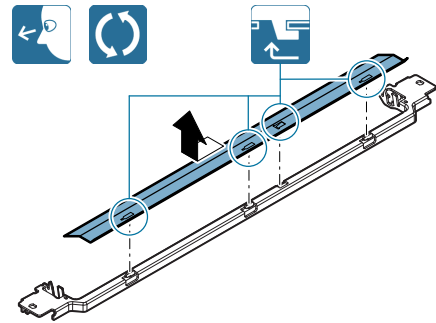

- Drive-type oil roller

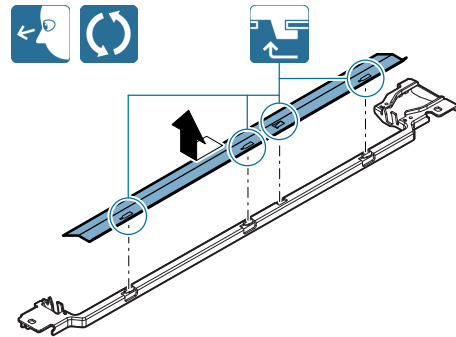

#### d. Lower thermistor

- 1) Remove the paper guide.

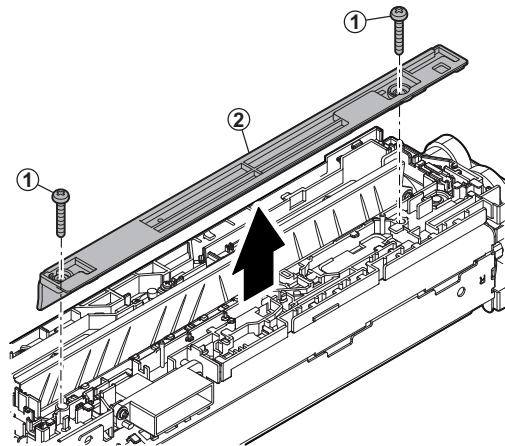

- 2) Disconnect the connector, and remove the mounting plate. Remove the lower thermistor from the mounting plate.

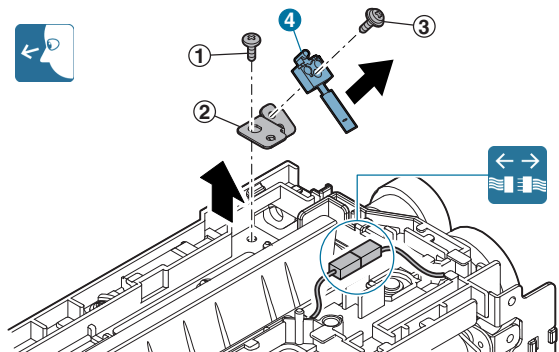

**e. Pressure roller gear, Pressure roller gear bearing, Pressure roller**

1) Remove the lower stay.

**Important**

Since paper dust and toner remain in the lower scraper assembly, be careful not to disperse them in the unit when handling.

- Follower-type oil roller

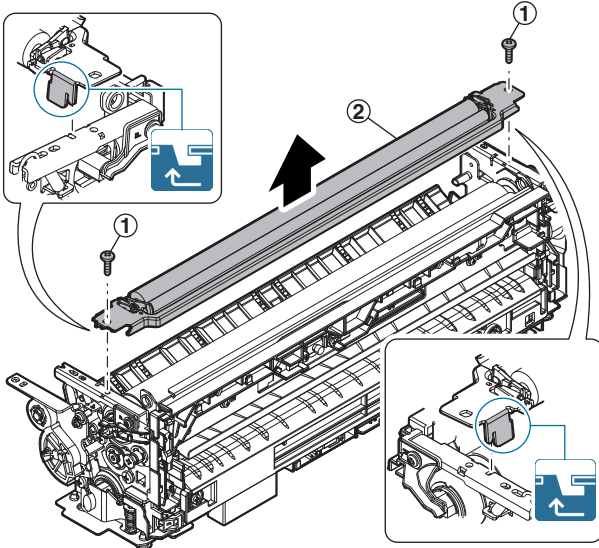

- Drive-type oil roller

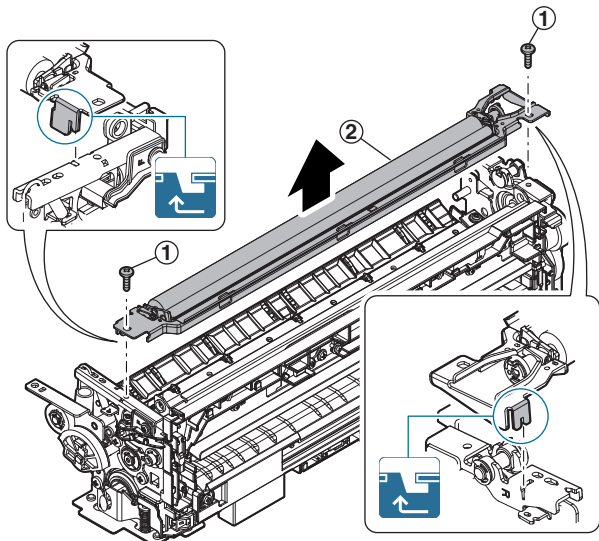

**Important**

When assembling the drive-type oil roller, fit the concave section of the shaft with the convex pawl of the coupling.

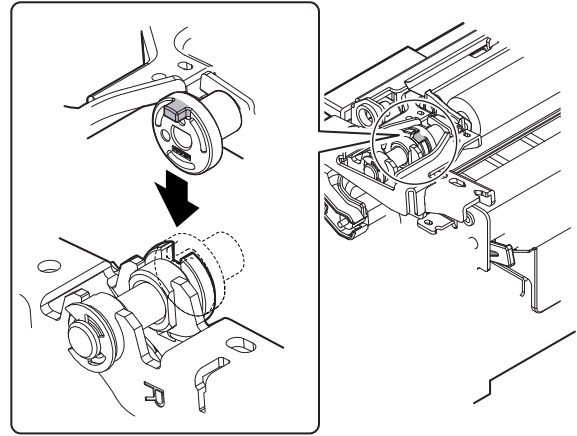

2) Remove the drive plate, and remove the gear.

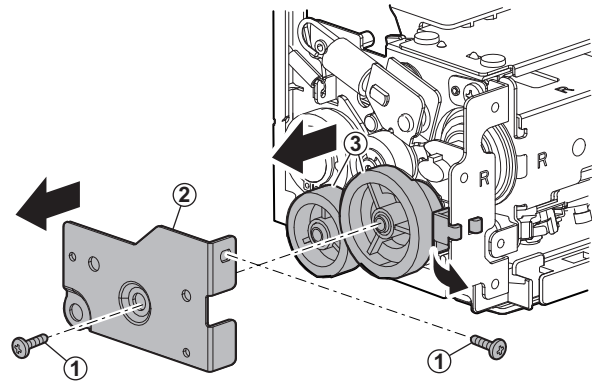

3) Disconnect the connector of the heater lamp. Remove the holder, and remove the heater lamp.

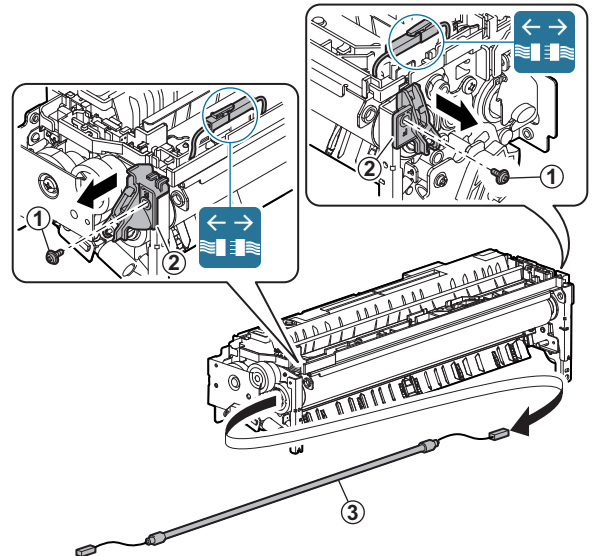

- Remove the C-ring, the pressure roller gear, and the pressure roller gear bearing.

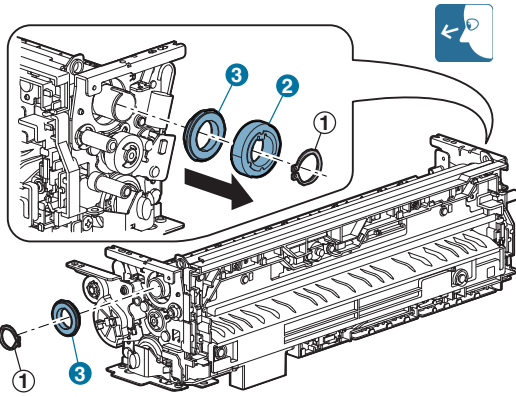

- Remove the pressure roller.

**Important**

When attaching the pressure roller, attach it with the protection sheet on it. After completion of assembly, remove the protection sheet.

**Important**

When replacing the pressure roller, apply grease (JFE552). In addition, wipe the pressure roller surface with alcohol.

**Important**

For removal of the pressure roller, remove the lower thermistor then remove the roller.

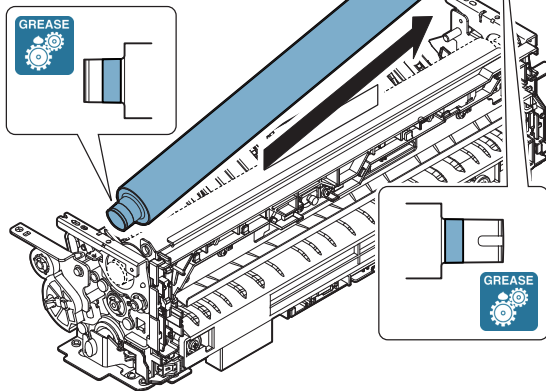

**f. Sub thermistor**

- Disconnect the connector, and remove the sub thermistor.

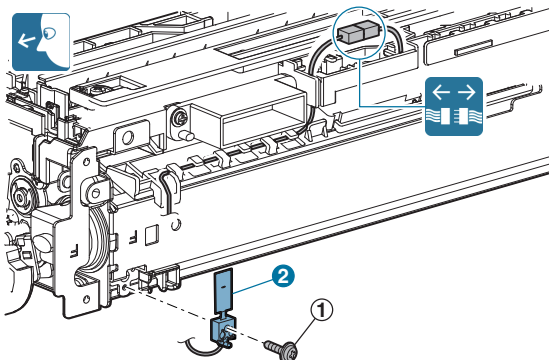

**g. Fusing roller bearing, heat-insulating bush, heating roller bearing, meandering suppress collar, fusing roller, heating roller, fusing belt**

- Remove the paper guide. Disconnect the connector.

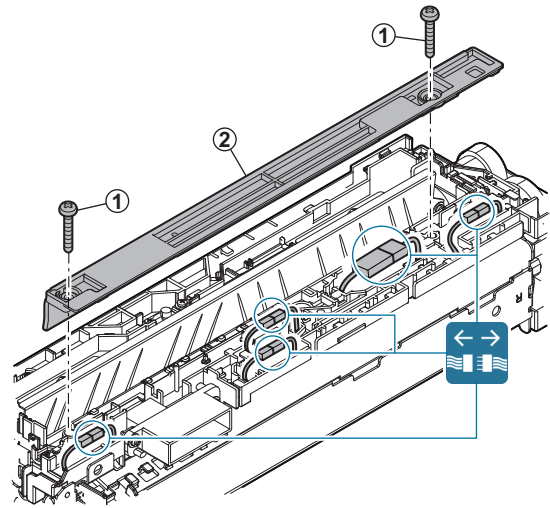

- Remove the spring. Remove the holder, and remove the heater lamp.

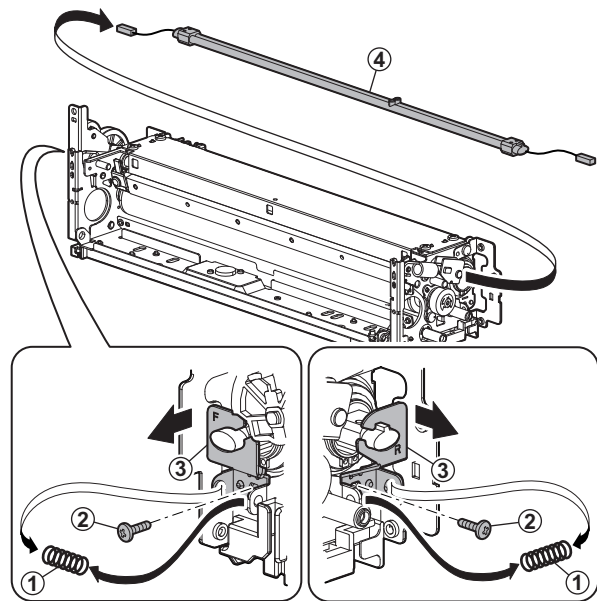

- Remove the E-ring, the gear, the fusing roller bearing, and the support plate.

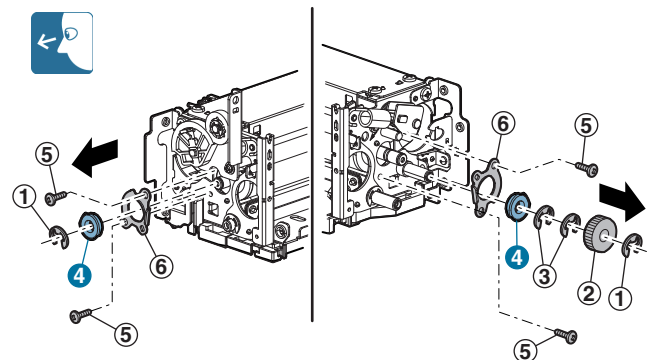

4) Remove the fulcrum plate, and remove the fusing belt unit.

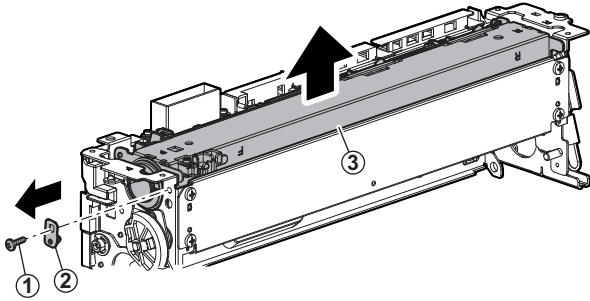

5) Remove the C-ring, the insulation bush, and the heating roller bearing.

**Important**

When replacing the insulation bush, apply grease (JFE552) to the inner race and the outer race.

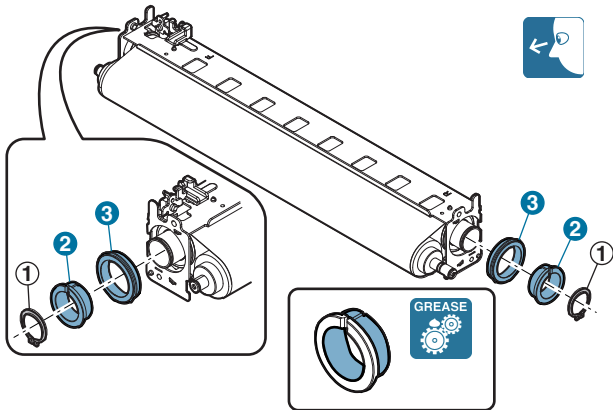

6) Remove the heating roller from the frame. Remove the washer and the meandering suppress collar from the heating roller. Remove the heating roller and the fusing roller from the fusing belt.

**Important**

When attaching the fusing belt, attach it with the protection sheet on it. After attaching the fusing roller bearing, remove the protection sheet.

**Important**

After attaching the fusing belt, wipe the belt surface with alcohol.

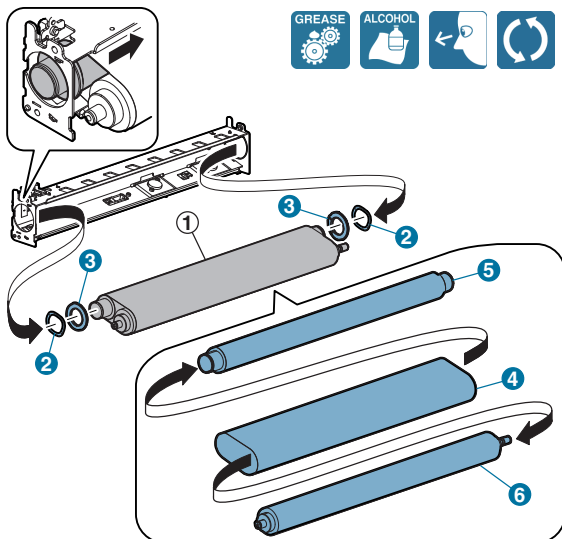

**Important**

When replacing the fusing roller, apply grease (JFE552) to the shaft section.

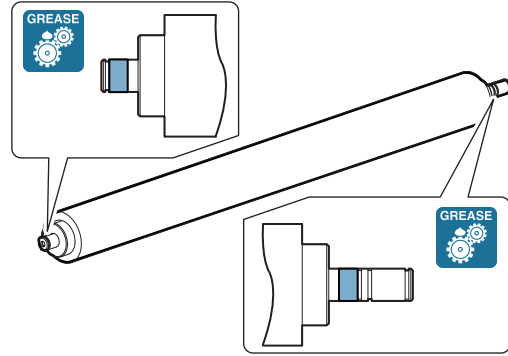

**Important**

When attaching the fusing pressure spring, perform the following procedures.

1) Slide the fusing belt unit to the front side, then to the rear side.

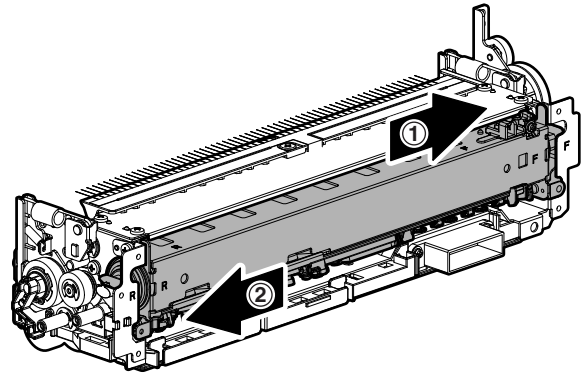

2) Attach the pressure spring, and connect the fusing heater lamp connector.

3) Shine a light through the clearance between the rear side of the fusing unit and the frame to confirm that there is a clearance between the fusing belt and the belt guide collar.

If there is a clearance between the fusing belt and the belt guide collar, black color on the surface of the fusing roller (F1) can be seen. It serves as a criterion of the judgment for presence of a clearance.

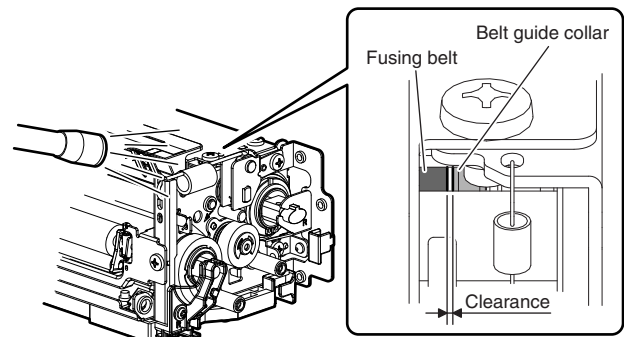



**Important**

When processing the fusing unit harness, note the following.  
 If the harness is improperly processed, short-circuit may occur.  
 Harness A should be passed over the earth terminal.

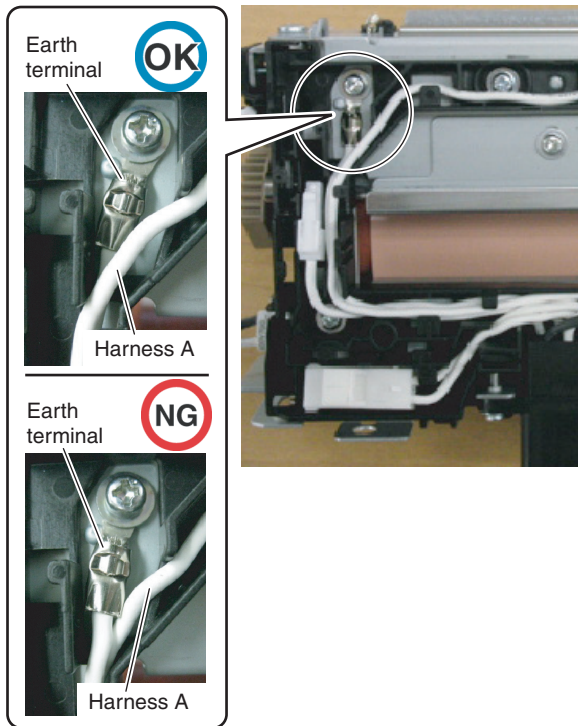

**(3) Fusing unit (36cpm machine)**

No.	Name
1	Lower separation pawl
2	Lower separation pawl spring
3	Separation plate
4	Web guide shaft
5	Web pressure roller bearing
6	Web pressure roller
7	Web roller
8	Lower thermistor
9	Pressure roller gear
10	Pressure roller gear bearing
11	Pressure roller
12	Sub thermistor
13	Fusing roller bearing
14	Insulation bush
15	Heating roller bearing
16	Meandering suppress collar
17	Fusing roller
18	Heating roller
19	Fusing belt
20	Washer

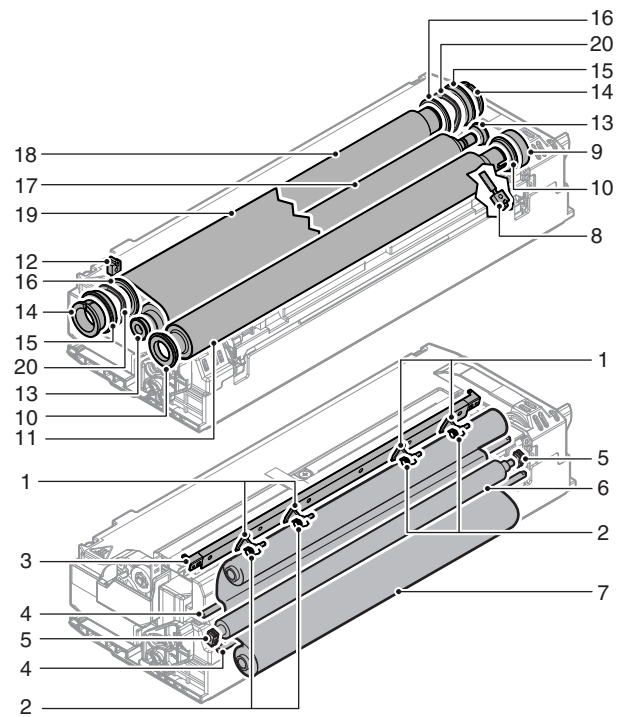

**a. Lower separation pawl, Lower separation pawl spring**

- 1) Open the fusing rear lower PG unit, and remove the fusing cover.

**Important**

When removing the fusing cover, lift the pawl section with a screwdriver (-) and remove.

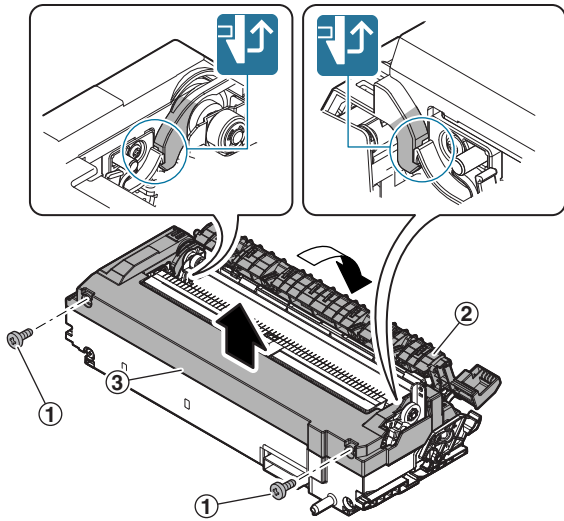

- 2) Remove the fusing rear lower PG unit.

**Important**

When removing, be careful not to lose the spring.

**Important**

When attaching, check to confirm that the spring hook is engaged.

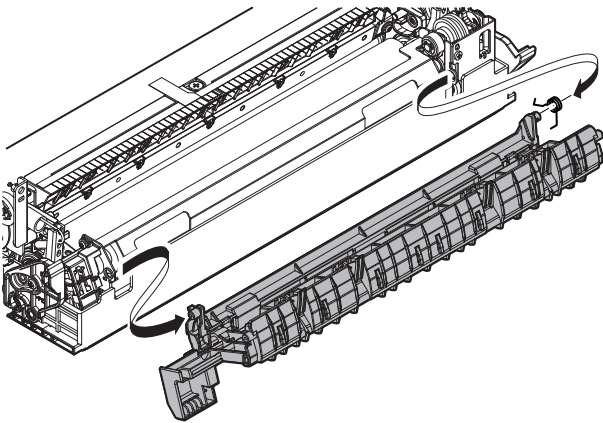

- 3) Remove the fusing cover.

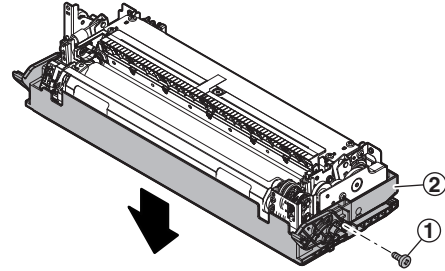
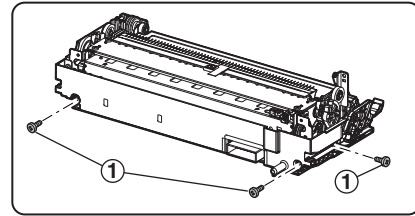

- 4) Remove the lower separation pawl and the lower separation pawl spring from the paper guide.

**Important**

When assembling, check to confirm that the hook of the lower separation pawl spring is engaged.

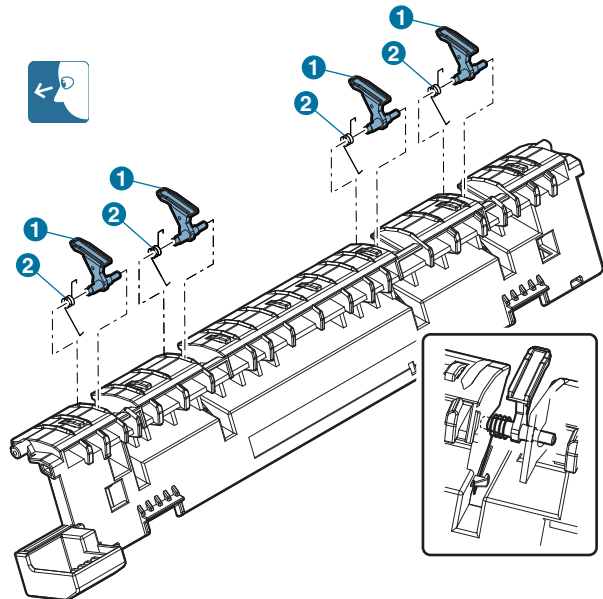

**b. Separation plate**

- 1) Remove the paper guide.

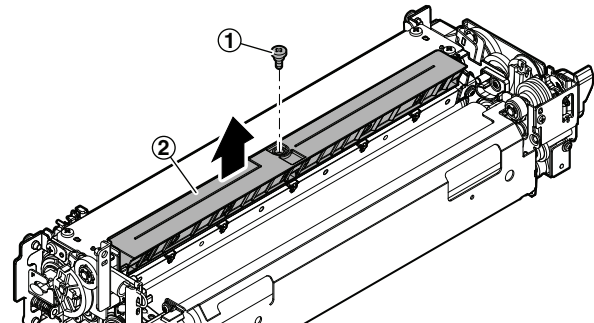

**Important**

After installing the separation plate and the paper guide, manually move the separation plate to check the operation.

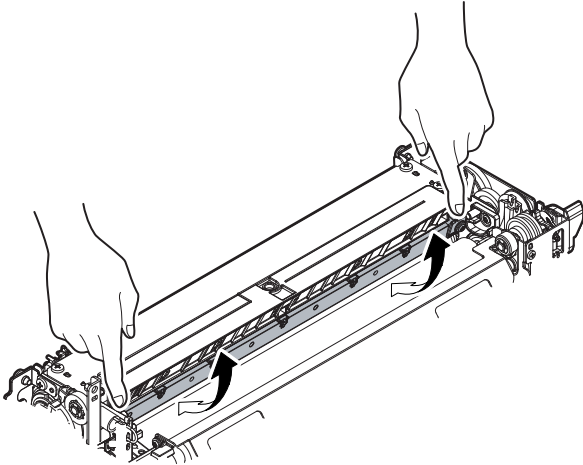

- 2) Remove the spring, and slide it to the front side, and remove the separation plate.

**Important**

Be careful not to damage or scratch the separation plate surface.

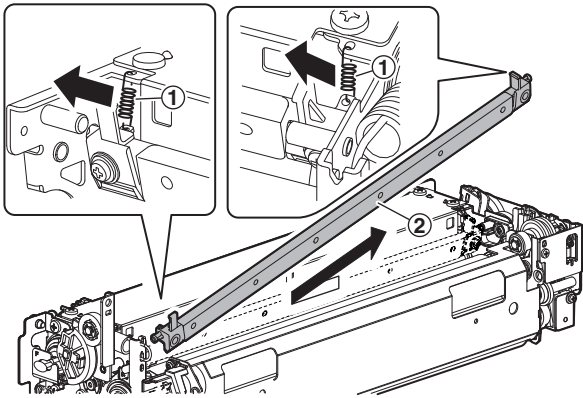

- 3) Remove the holder, from the separation plate.

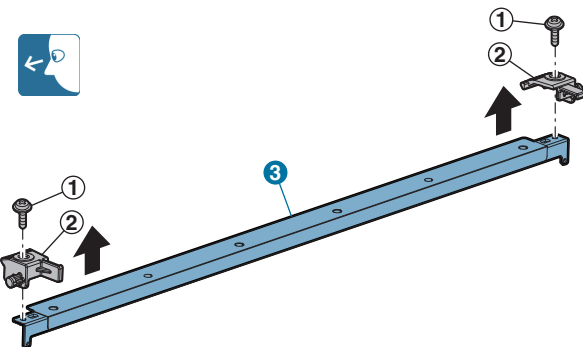

**c. Web guide shaft, Web pressure roller bearing, Web pressure roller, Web roller**

- 1) Disconnect the connector and remove the harness. Remove the web unit.

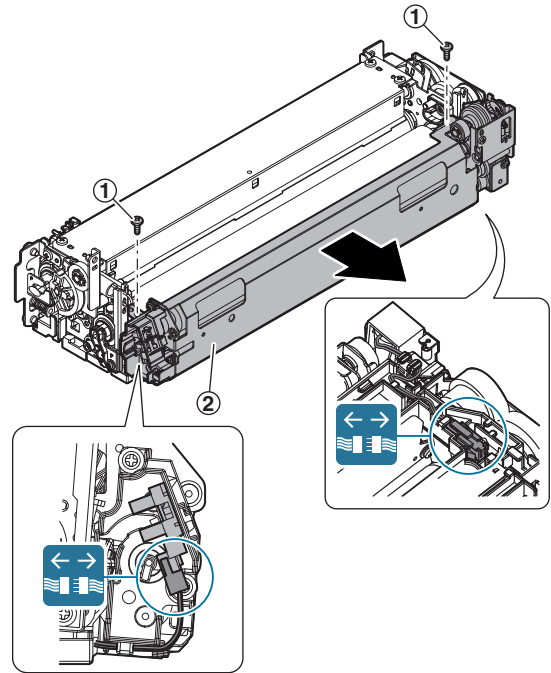

- 2) Remove the holder.

**Important**

When assembling, place the actuator tip on the outside of the web sheet.

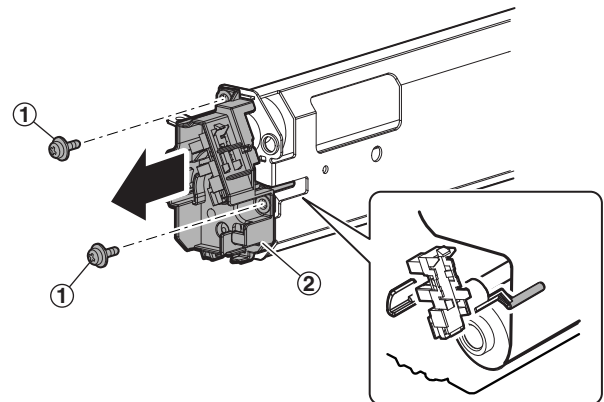

- 3) Remove the web guide shaft.

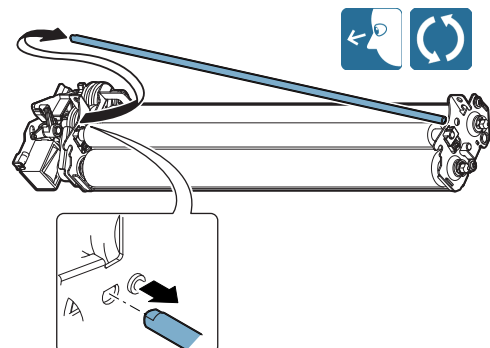

4) Remove the web roller (on the winding side).

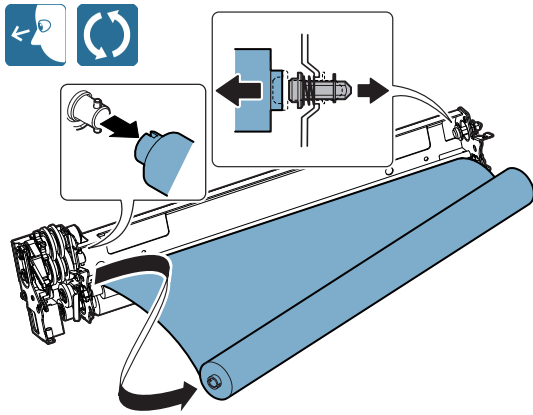

7) Remove the web roller (on the feeding side).

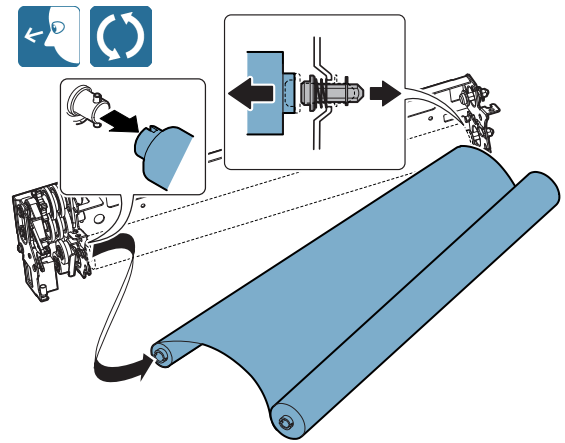

5) Remove the spring and the web pressure roller bearing, and remove the web pressure roller.

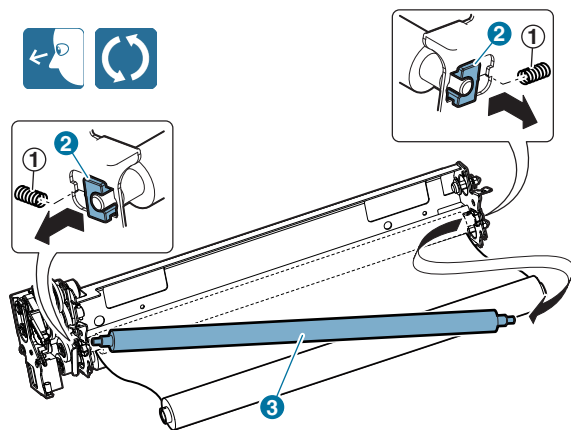

**Important**

After assembling the web unit, rotate the drive gear until the end position of the start mark on the web sheet comes to the pressure roller.

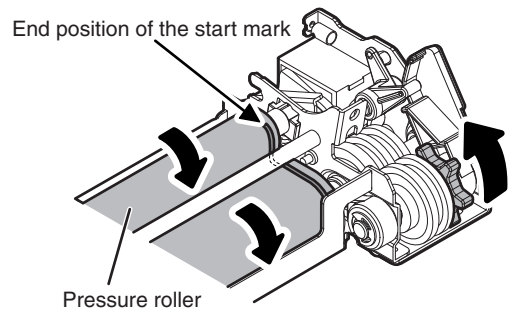

6) Remove the web guide shaft.

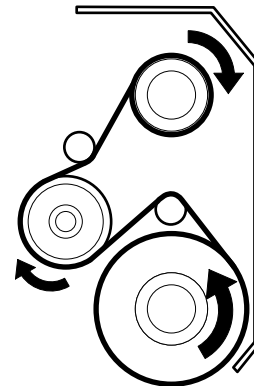
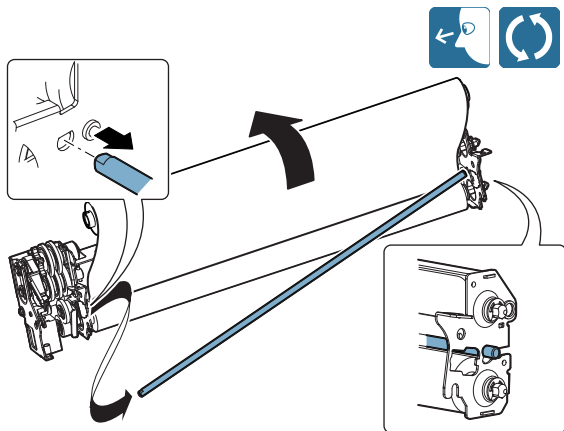

**d. Lower thermistor**

- 1) Remove the paper guide.

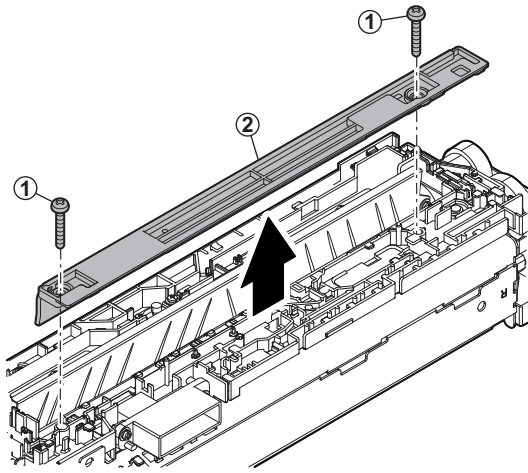

- 2) Disconnect the connector, and remove the mounting plate. Remove the lower thermistor from the mounting plate.

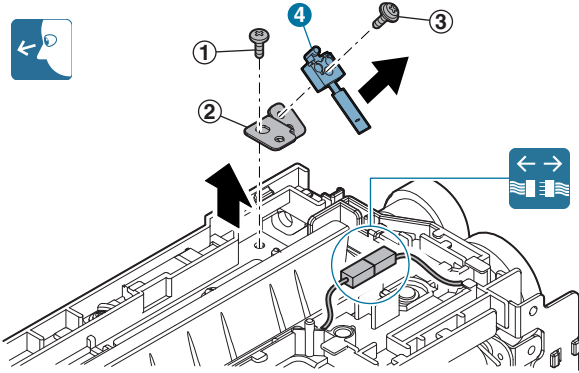

**e. Pressure roller gear, Pressure roller gear bearing, Pressure roller**

- 1) Remove the drive plate, and remove the gear.

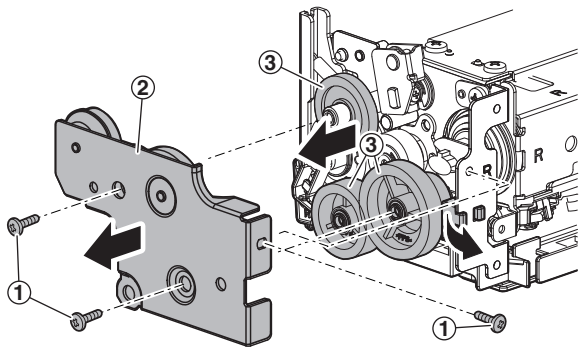

- 2) Disconnect the connector of the heater lamp. Remove the holder, and remove the heater lamp.

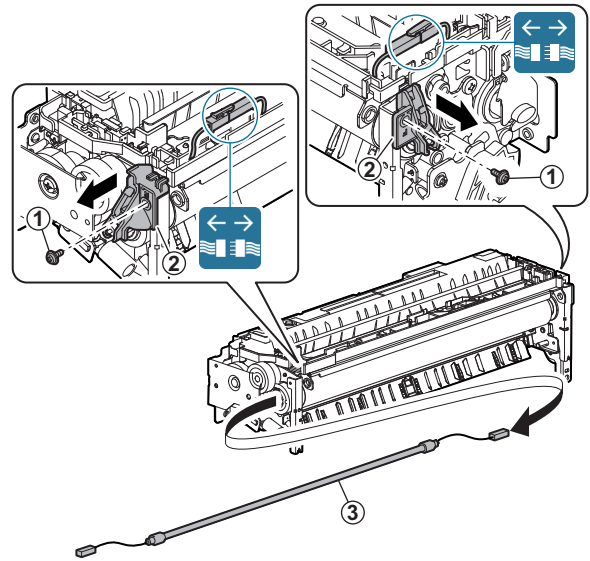

- 3) Remove the C-ring, the pressure roller gear, and the pressure roller gear bearing.

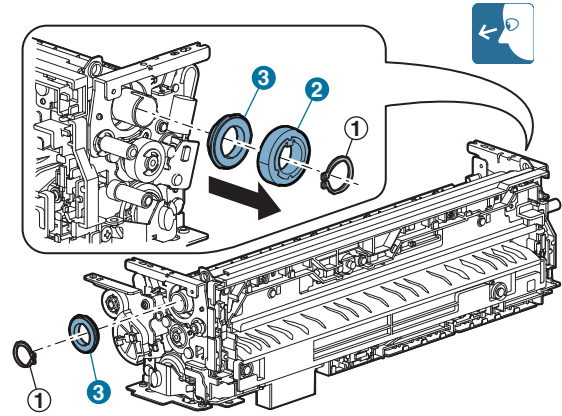

- 4) Remove the pressure roller.

**Important**

When attaching the pressure roller, attach it with the protection sheet on it. After completion of assembly, remove the protection sheet.

**Important**

When replacing the pressure roller, apply grease (JFE552). In addition, wipe the pressure roller surface with alcohol.

**Important**

For removal of the pressure roller, remove the lower thermistor then remove the roller.

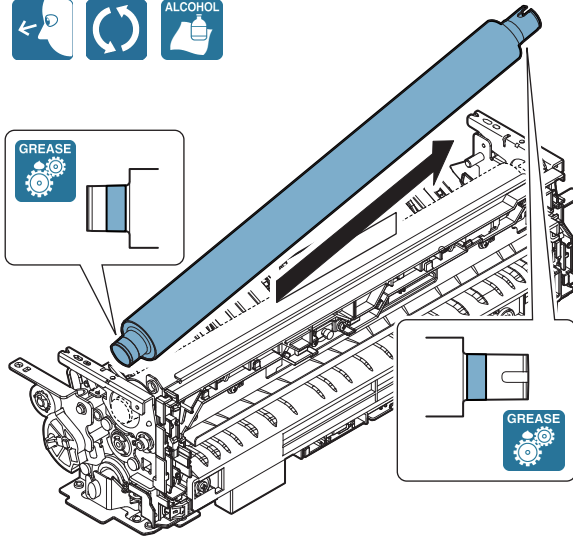

**f. Sub thermistor**

- 1) Disconnect the connector, and remove the sub thermistor.

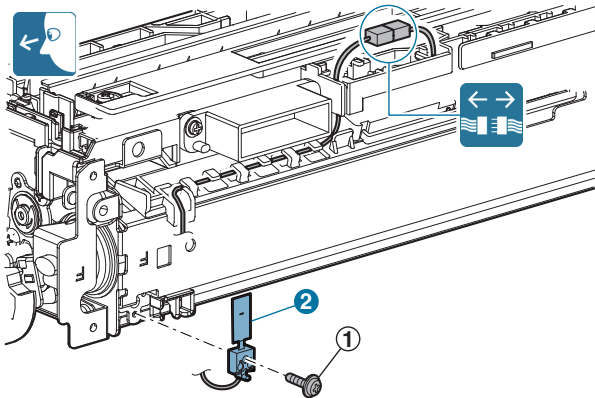

**g. Fusing roller bearing, heat-insulating bush, heating roller bearing, meandering suppress collar, fusing roller, heating roller, fusing belt**

- 1) Remove the paper guide. Disconnect the connector.

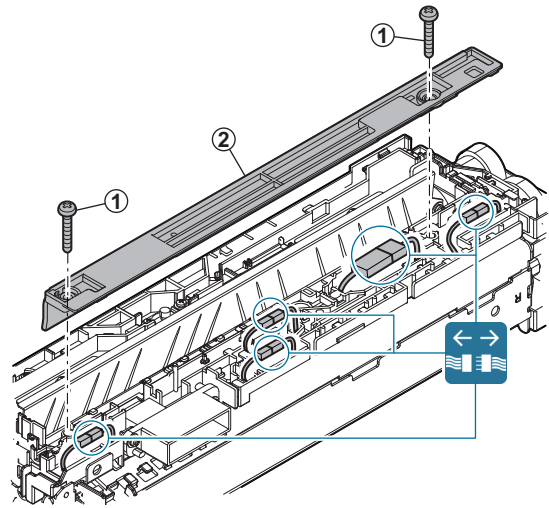

- 2) Remove the spring. Remove the holder, and remove the heater lamp.

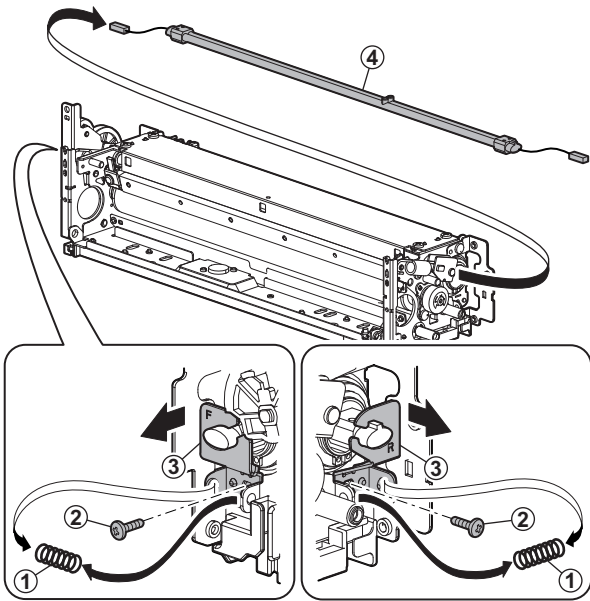

- 3) Remove the E-ring, the gear, the fusing roller bearing, and the support plate.

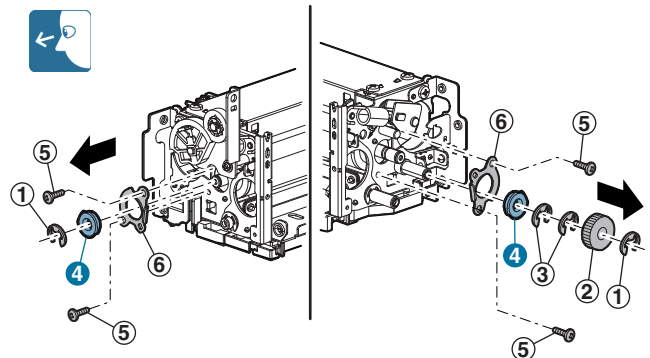

4) Remove the fulcrum plate, and remove the fusing belt unit.

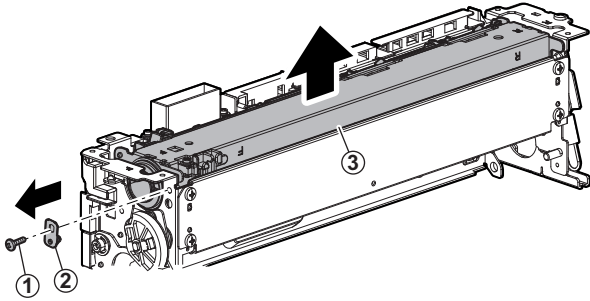

5) Remove the C-ring, the insulation bush, and the heating roller bearing.

**Important**

When replacing the insulation bush, apply grease (JFE552) to the inner race and the outer race.

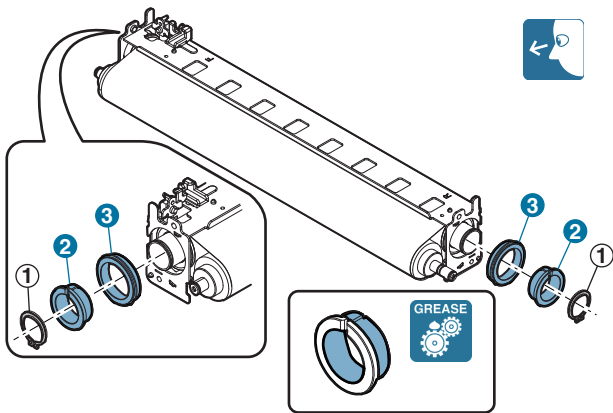

6) Remove the heating roller from the frame. Remove the washer and the meandering suppress collar from the heating roller. Remove the heating roller and the fusing roller from the fusing belt.

**Important**

When attaching the fusing belt, attach it with the protection sheet on it. After attaching the fusing roller bearing, remove the protection sheet.

**Important**

After attaching the fusing belt, wipe the belt surface with alcohol.

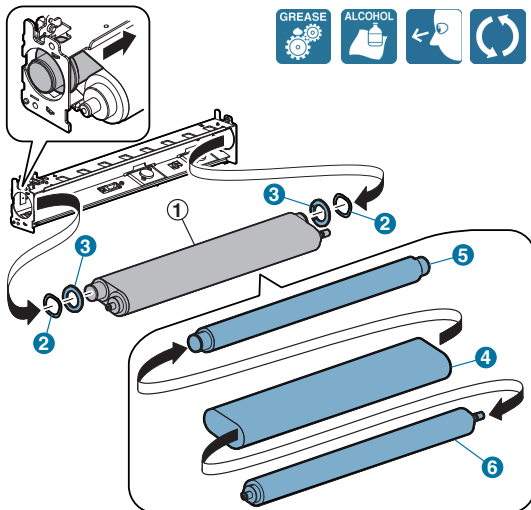

**Important**

When replacing the fusing roller, apply grease (JFE552) to the shaft section.

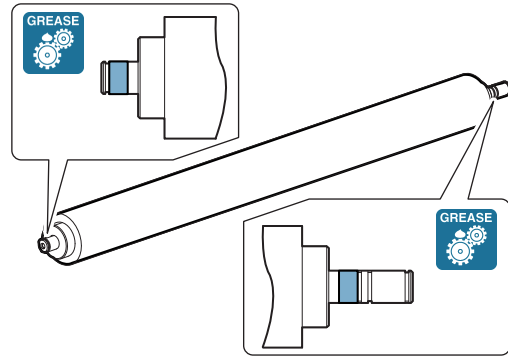

**Important**

When attaching the fusing pressure spring, perform the following procedures.

1) Slide the fusing belt unit to the front side, then to the rear side.

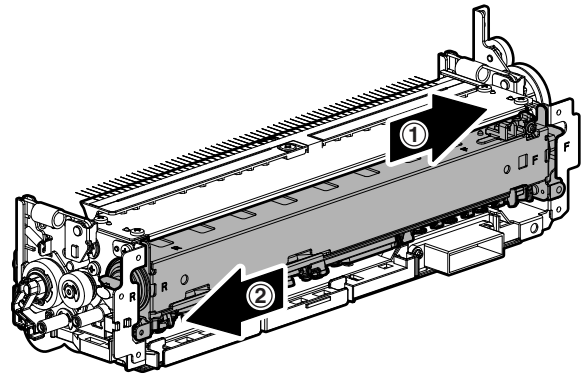

2) Attach the pressure spring, and connect the fusing heater lamp connector.

3) Shine a light through the clearance between the rear side of the fusing unit and the frame to confirm that there is a clearance between the fusing belt and the belt guide collar.

If there is a clearance between the fusing belt and the belt guide collar, black color on the surface of the fusing roller (F1) can be seen. It serves as a criterion of the judgment for presence of a clearance.

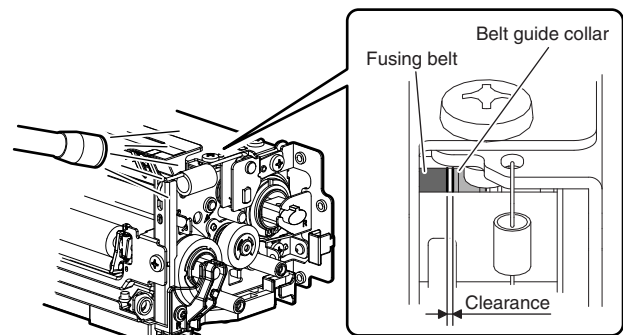

**Important**

When processing the fusing unit harness, note the following.  
If the harness is improperly processed, short-circuit may occur.  
Harness A should be passed over the earth terminal.

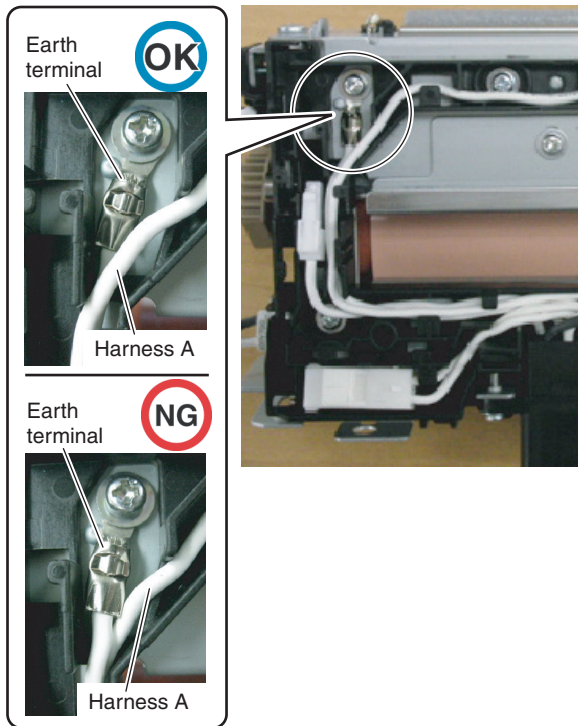

**Important**

For connection of the power switch connector, follow the procedures below.  
Be sure to identify the colors and connecting directions of the connector and the wire.

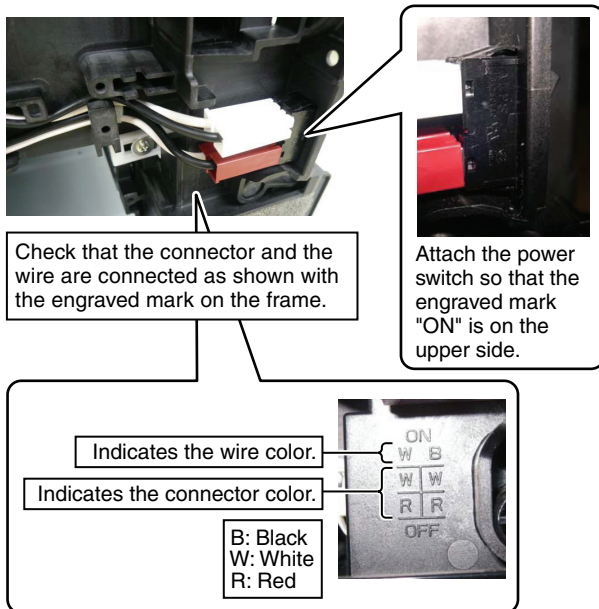



# [10] VARIOUS STORAGE DATA HANDLING

## 1. HDD/SD card memory map

### A. HDD partition

18cpm/20cpm (Option HDD installed)/23cpm/31cpm(G) machine

HDD size = 160GB (Actual size 149GB)

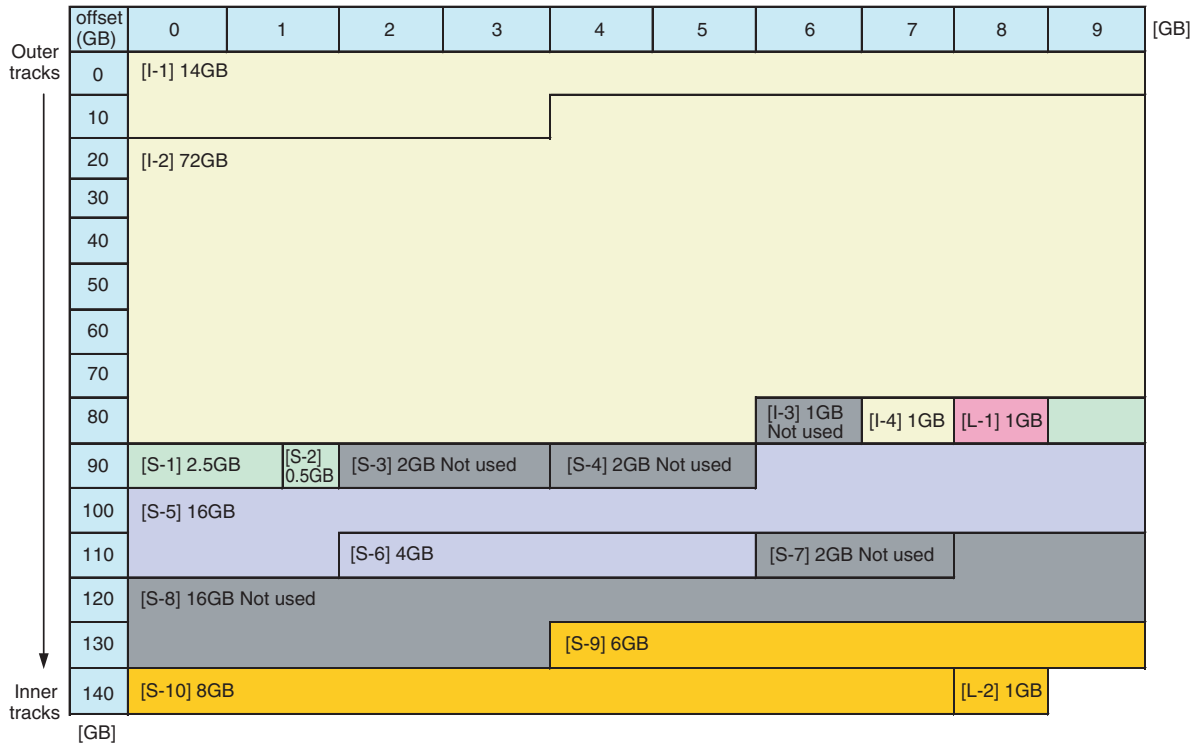

26cpm/36cpm/31cpm(A) machine

HDD size = 160GB (Actual size 149GB)

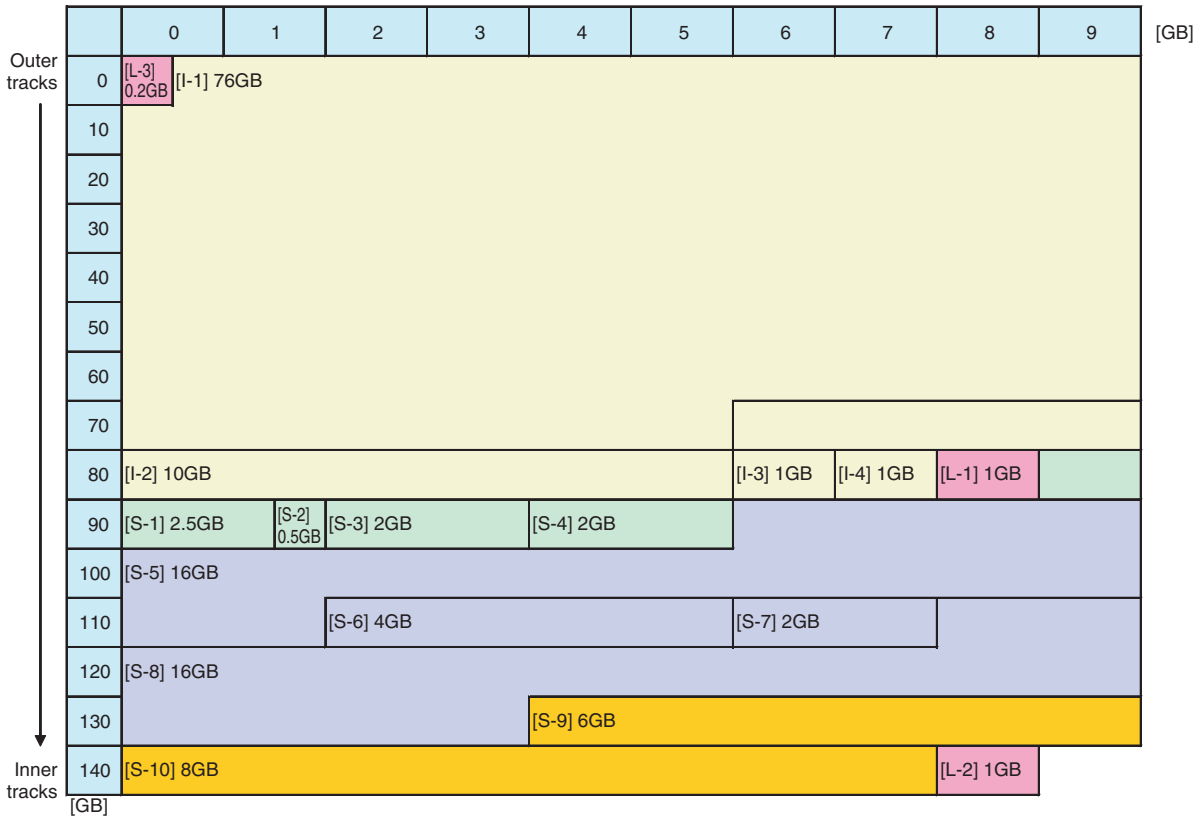

## B. HDD data contents

### 18cpm/20cpm (Option HDD installed)/23cpm/31cpm(G) machine

No.	File system	Stored data	NOTE
I-1	Image data	Image data (ERDH/Temporary storage)	1000 documents, 3000 images
I-2	Image data	Image data (Document filing)	3000 documents, 20000 images
I-3	Image data	Not available	Not used
I-4	Image data	FAX/Internet Fax receive images (for backup) (SD Card I101 area data backup)	
L-1	Not available	System storage data (Address book, image send system registration data (sender's information, meta data, etc.), FSS collection data)	
S-1	Universal	Download font User profile User macro Database system file System log System setting data (Backup)	
S-2	Universal	Document filing (Database) Job log (Database) Job completion list	
S-3	Universal	Not available	Not used
S-4	Universal	Not available	Not used
S-5	Universal	Spool area for printer	
S-6	Universal	Application work area (User file used in USB direct print)	
S-7	Universal	Not available	Not used
S-8	Universal	Not available	Not used
S-9	Universal	Data backup when installing DSK (User data (Address book, account information))	
S-10	Universal	e-manual Watermark	
L-2	Universal	Not available	Not used

### 26cpm/36cpm/31cpm(A) machine

No.	File system	Stored data	NOTE
L-3	Not available	UI content data	
I-1	Image data	Image data (ERDH/Document filing)	3000 documents, 20000 images
I-2	Image data	Image data (Temporary storage)	1000 documents, 3000 images
I-3	Image data	Image data (User watermark/stamp)	
I-4	Image data	FAX/Internet Fax receive images (for backup) (SD Card I101 area data backup)	
L-1	Not available	System storage data (Image send system registration data (sender's information, meta data, etc.), FSS collection data)	
S-1	Universal	Download font User profile User macro Database system file System log System setting value data (Backup)	
S-2	Universal	Document filing (Database) Job log (Database) Job completion list	
S-3	Universal	Address book (Database) Account management information (Database) Individual setting information for direct WEB browsing Cookie file for OSA application	
S-4	Universal	Database file (save area for collective erasing)	
S-5	Universal	Spool area for printer	
S-6	Universal	Application work area (User file used in USB direct print)	
S-7	Universal	eOSA application file	
S-8	Universal	User file saved in the SMB server	
S-9	Universal	User data of set values, etc. which must not be erased when installing the DSK. (Address book, account information)	
S-10	Universal	e-manual/html help Watermark	
L-2	Universal	Mirroring information (When the mirroring kit is installed, the mirroring information is written.)	

### C. SD card partition

#### 18cpm machine (Option HDD uninstalled)

SD card size = 4GB (Actual size 3.6GB)

	0	100	200	300	400	500	600	700	800	900	[MB]	
0	[L-101] 512MB					[S-101] 40MB	[S-102] 40MB	[S-105] 40MB	[S-103] 900MB			
1						[S-104] 40MB	[I-101] 512MB					
2		[I-102] 512MB					[I-103] 1000MB					
3												

[GB]

#### 20cpm machine (Option HDD uninstalled)

SD card size = 8GB (Actual size 7.2GB)

	0	100	200	300	400	500	600	700	800	900	[MB]
0	[L-101] 500MB					[S-101] 200MB		[S-102] 200MB		[S-105] 100MB	
1	[S-103] 924MB										
2	[S-104] 200MB	[I-101] 500MB				[I-102] 500MB					
3											
4											
5	[I-103] 4GB										
6											
7											

[GB]

#### 18cpm/20cpm (Option HDD installed)/23cpm/26cpm/31cpm/36cpm machine

SD card size = 4GB (Actual size 3.6GB)

	0	100	200	300	400	500	600	700	800	900	[MB]	
0	[L-101] 500MB					[S-101] 500MB						
1	[S-102] 500MB					[S-105] 100MB	[S-103] 924MB					
2						[I-101] 1GB						
3												

[GB]

## D. SD card data contents

### 18cpm/20cpm machine (Option HDD uninstalled)

No.	File system	Stored data	NOTE
L-101	Not available	ICU firmware (Boot/Main) Boot animation Boot (CN Update mode) ARM9 firmware lang.sfu (language data) graph.sfu (Animation data)	
S-101	Universal	font web help spdl Option FontROM	
S-102	Universal	S-101 area data backup (mirror)	
S-105	Universal	Setting value data file (System setting/SIM setting data (Image quality adjustment)/FAX Soft SW)	
S-103	Universal	Key operator setting storage data IMS job management data FAX reception data (For power shut off and paper empty) FEP leaning data (Japanese/Chinese) Firmware update data (differential between new and old) (For FSS) Account management information/User authentication data System log	
S-104	Universal	S-105 area data backup (mirror)	
I-101	Image data	FAX/Internet Fax receive images	
I-102	Image data	FAX/Internet Fax receive images (Backup)	Not used when an option HDD is installed.
I-103	Image data	ERDH work	

### 18cpm machine (Option HDD installed)

No.	File system	Stored data	NOTE
L-101	Not available	ICU firmware (Boot/Main) Boot animation Boot (CN) ARM9 firmware lang.sfu graph.sfu	
S-101	Universal	font web help spdl Option FontROM	
S-102	Universal	Same as above (Mirror)	
S-105	Universal	Setting value data file	
S-103	Universal	Key operator setting storage data IMS job management data FAX reception data (For power shut off and paper empty) FEP leaning data (Japanese/Chinese) Firmware update data (differential between new and old) Account management information	
I-101	Image data	FAX/Internet Fax receive images	

### 20cpm (Option HDD installed)/23cpm/31cpm(G) machine

No.	File system	Stored data	NOTE
L-101	Not available	ICU firmware (Boot/Main) Boot animation Boot (CN Update mode) ARM9 firmware lang.sfu (language data) graph.sfu (Animation data)	
S-101	Universal	font web help spdl Option FontROM	
S-102	Universal	Same as above (Mirror)	
S-105	Universal	Setting value data file (System setting/SIM setting data (Image quality adjustment)/FAX Soft SW)	
S-103	Universal	Key operator setting storage data FAX reception data (For power shut off and paper empty) FEP leaning data (Japanese/Chinese) Firmware update data (differential between new and old) (For FSS) Account management information/User authentication data	
I-101	Image data	FAX/Internet Fax receive images	

26cpm/36cpm/31cpm(A) machine

No.	File system	Stored data	NOTE
L-101	Not available	ICU firmware (Boot/Main) Boot animation Boot (CN) ARM9 firmware lang.sfu graph.sfu	
S-101	Universal	font web help spd1 Option FontROM  UI Action Script main program UI screen information (XML data) Flash image Flash language data Flash guidance animation	
S-102	Universal	Same as above (Mirror)	
S-105	Universal	Set value data file	
S-103	Universal	Key operator setting storage data FAX reception data (For power shut off and paper empty) FEP leaning data (Japanese/Chinese)  For storing differential update data Account management information/User authentication data	
I-101	Image data	FAX/Internet Fax receive images	

## 2. Necessary steps when replacing the PWB, HDD and the SD Card

### A. MFP substrate replacement procedure (work flow)

#### Important

Registered user information will not be recovered if the MFP PWB is affected by U2-05 trouble. (\*1)

- 1) Attach the flash ROM, the memory, the EEPROM, the SD card etc. of the MFP PWB on the service parts MFP PWB and install it to the main unit.

#### Important

Ground your body with grounding band during the work.

- 2) When U2 trouble occurs, use SIM16 to cancel it.
- 3) Set as follows after restarting the main unit.

At this timing, F6-21 may occur. Whether it may occur or not, go to execute procedure 1.

- (1) Set the appropriate country code by Sim66-02 (clear the software switches related to FAX).

#### Important

Make sure to execute even if the fax option is not installed on the machine.

### B. Procedures necessary for HDD replacement

#### Note for HDD replacement

- Data of the following list are saved in the HDD of the complex machine. If the HDD operates normally and data backup is possible before replacement, perform data backup and then replace the HDD.
- If the HDD does not operate normally, data cannot be backed up.
- The HDD replacement procedures with a broken HDD differs from that with a normal HDD.

#### Contents of this chapter

- HDD storage data and backup
- Replacement procedures when HDD storage data can be backed up
- Replacement procedures when HDD storage data cannot be backed up due to breakdown of HDD
- Reinstall and update procedures of Operation Manual data saved in HDD
- Reinstall and update procedures of watermark data.

## (1) HDD storage data and backup

Some HDD storage data can be backed up, and some other data cannot. Some HDD storage data can be reinstalled, and some other storage data cannot.

If the HDD operates normally before replacement and data can be backed up, back up the data before replacement of the HDD referring to the HDD storage data list. Then reinstall the data after replacement of the HDD.

### a. HDD storage data list

No.	Data kind	Before installation (When shipping from the factory)	After installation (After use by users)	Enable/ Disable of data backup	Backup means	Enable/ Disable of data reinstall	Data reinstall procedures	Reinstall operator
1	e-Manual	Available	Available	Disable	*1	Enable	Sim49-3	Service
2	Address book	Not available	Available	Enable	Sim56-2 / Device cloning / Storage backup	Enable	Sim56-2 / Device cloning / Storage backup	Service
3	Image send series registration data (Sender's information, meta data, etc.)	Not available	Available	Enable	Sim56-2 / Device cloning / Storage backup	Enable	Sim56-2 / Device cloning / Storage backup	Service
4	User authentication Account management	Not available	Available	Enable	Sim56-2	Enable	Sim56-2	Service
5	Japanese FEP dictionary (Learning)	Not available	Available	Disable	Not available	Disable		—
6	Chinese FEP dictionary (Learning)	Not available	Available	Disable	Not available	Disable		—
7	JOB LOG	Not available	Available	Enable	Perform with WEB PAGE.	Disable		—
8	JOB completion list	Not available	Available	Disable	Not available	Disable		—
9	New N/A (FSS) information	Not available	Available	Disable	Not available	Disable		—
10	User font (Added)	Not available	Available	Disable	Not available	Enable	Perform with WEB PAGE.	Service or User
11	User macro	Not available	Available	Disable	Not available	Enable	Perform with WEB PAGE.	
12	Document filing	Not available	Available	Enable	Perform with WEB PAGE.	Enable	Perform with WEB PAGE.	
13	Some of system setting data	Not available	Available	Enable	Sim56-2 / Device cloning / Storage backup	Enable	Sim56-2 / Device cloning / Storage backup	Service
14	Watermark	Available	Available	Disable	*2	Enable	Sim49-5	Service
15	User color profile	Not available	Available	Disable	Not available	Enable	Perform with WEB PAGE.	Service
16	Mirroring information (When the mirroring kit is installed, the mirroring information is written.)	Not available	Available (After installation of the mirroring kit)	Disable	Not available	Enable	The mirroring information is erased by forcible build or RIB BUSTER.	Service
17	Individual setting information for direct WEB browsing	Not available	Available	Disable		Disable		Service
18	Cookie file for OSA application	Not available	Available	Disable		Disable		Service
19	eOSA application file	Not available	Installation of application	Disable		Enable	Reinstallation of application	Service
20	User file saved in the SMB server (NAS)	Not available	Available	Disable		Disable		Service

\*1: The e-Manual cannot be backed up, but can be reinstalled by using Sim49-3 and USB memory.

\*2: Watermark data cannot be backed up, but can be reinstalled by using Sim49-5 and USB memory.

**(2) Replacement procedures when HDD data can be backed up**

**a. Work contents and procedures**

Procedures	When a new HDD (blank HDD, service part) is used, or when a HDD which is normal but a program error occurs in it is used.	When a used HDD (used in the same model) is used *
Step 1	Back up the HDD storage data before replacement. (Servicing) Use SIM56-2 or the device cloning, or the storage backup function to backup the data. (Back up the data to the USB memory.) (Backup enable data: HDD storage data list No. 2, 3, 4 (Address book, Image send series registration data, User authentication data))	
Step 2	Back up the HDD storage data before replacement. (User or servicing) Back up the data to PC with Web page. (Backup enable data: HDD storage data list No. 7, 10, 14 (Document filing data, JOB LOG data))	
Step 3	When there are some FAX or Internet Fax data, use SIM66-62 to backup the image data from the SD card to the USB memory. (The backup image data are of PDF file type, and cannot be restored to the machine. The backup data are given to the user.)	
Step 4	Replace the HDD.	
Step 5	Boot the complex machine. → Formatting is automatically performed.	Boot the complex machine.
Step 6		The trouble code, U2-05, is displayed. → Cancel with SIM16.
Step 7	Since a blank HDD is automatically formatted, there is no need to perform formatting procedure with SIM.	Use SIM62-1 to format the HDD.
Step 8	Use SIM66-10 to clear the FAX image memory. The memory is cleared in order to keep compliance between the HDD data and the image related memory and to prevent malfunctions. (The memory must be cleared not only in the FAX model but in the scanner and the Internet Fax models.)	
Step 9	Use SIM49-3 to install the manual data to the HDD.	
Step 10	The trouble code, U2-60, is displayed. → Use SIM49-5 to install the watermark data to the HDD. → After booting the machine, use SIM16 to cancel the "U2-60" trouble.	
Step 11	Import the data backed up in Step 1. Use SIM56-2, or the device cloning, or the storage backup to import. (Import enable data: HDD storage data list No. 2, 3, 4 (Address book, Image send series registration data, User authentication data))	
Step 12	Import the data backed up with the Web page function in Step 2. Import enable data: Document filing data, User font, Use macro (The JOB LOG data can be backed up but cannot be imported.)	

**(3) Replacement procedures when the HDD storage data cannot be backed up due to breakdown**

**a. Display when HDD breakdown**

When a trouble occurs in the HDD, the error code display of E7-03 is popped up.

In this case, the main power must be turned OFF and the HDD must be replaced.

**b. Work contents and procedures**

Procedures	When a new HDD (blank HDD, service part) is used, or when a HDD which is normal but a program error occurs in it is used.	When a used HDD (used in the same model) is used *
Step 1	Install a HDD to the machine, and boot the complex machine. → Formatting is automatically performed.	Install a HDD to the machine, and boot the complex machine.
Step 2		The trouble code, U2-05, is displayed. → Cancel with SIM16.
Step 3	Since a blank HDD is automatically formatted, there is no need to perform formatting procedure with SIM.	Use Sim62-1 to format the HDD.
Step 4	When there are some FAX or Internet Fax data, use SIM66-62 to backup the image data from the SD card to the USB memory. (The backup image data are of PDF file type, and cannot be restored to the machine. The backup data are given to the user.)	
Step 5	Use SIM66-10 to clear the FAX image memory. The memory is cleared in order to keep compliance between the HDD data and the image related memory and to prevent malfunctions. (The memory must be cleared not only in the FAX model but in the scanner and the Internet Fax models.)	
Step 6	Use SIM49-3 to install the manual data to the HDD.	
Step 7	The trouble code, U2-60, is displayed. → Use SIM49-5 to install the watermark data to the HDD. → After booting the machine, use SIM16 to cancel the "U2-60" trouble.	

With the above procedures, the HDD is reset to the state of factory shipping.



#### (4) Reinstall and update procedures of the HDD storage Operation Manual data

- 1) Obtain the Operation Manual data.  
Download the Operation Manual data from the utility menu on the web site (Tech-DS home page).  
Copy the downloaded files to the USB device without changing the file hierarchy.

##### 23cpm/31cpm(G) machine

To upload to the complex machine, files of "\*\*\*\_pdf\_fax.idx" and "\*\*\*\_pdf.idx" and "version.txt" as well as the Operation Manual data (\*\*.pdf) are required. When the downloaded files are copied without changing the file hierarchy, these files also are copied.

##### 26cpm/31cpm(A)/36cpm machine

For the above models, there is only one file (\*\*.uar).

#### Note

When data are uploaded from the USB memory to the HDD, if there are some data in the HDD, the files in the memory are compared with the files in the HDD and only the files which satisfy the following conditions are written into the HDD.

- The file size is different.
- The time stamp is different.
- The file exists only in the USB memory.

#### Important

The data backed up with SIM56-2 must not be installed to another machine. If installed, the adjustment data will be overwritten and a trouble may be generated.

- 2) Enter the SIM49-3 mode.

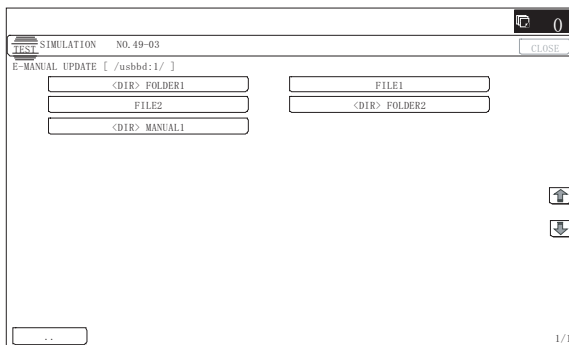

- 3) Insert the USB memory into the machine.
  - When the USB memory is not inserted, "INSERT A STORAGEE-MANUAL STORED ON" is displayed. When [OK] button is pressed, the screen shifts to the folder select menu 1.
- 4) Select the folder of the Operation Manual data. (The screen shifts to the Operation Manual data install menu.)  
The current version and the update version are displayed.
- 5) Press [EXECUTE] button.  
[EXECUTE] button is highlighted, and [YES] and [NO] buttons are changed from gray-out to active display.
- 6) When [YES] button is pressed, the selected Operation Manual is installed.  
When install is completed, "COMPLETE" is displayed. In case of an abnormality, "ERROR" is displayed.

#### (5) Watermark data reinstall and update procedures

- 1) Obtain the watermark data.  
Download the watermark data from the utility menu on the web site (Tech-DS home page).  
Copy the downloaded files to the USB device without changing the file hierarchy.

#### Note

When data are uploaded from the USB memory to the HDD, if there are some data in the HDD, the files in the memory are compared with the files in the HDD and only the files which satisfy the following conditions are written into the HDD.

- The file size is different.
  - The time stamp is different.
  - The file exists only in the USB memory.
- 2) Enter the SIM49-5 mode.

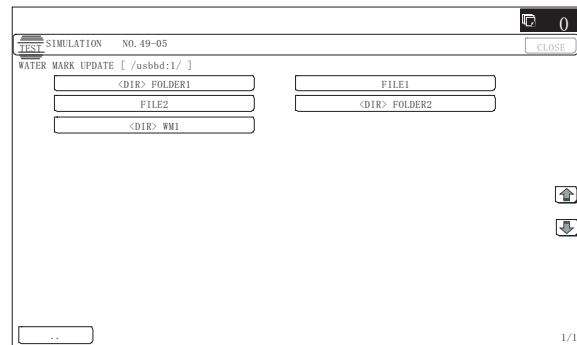

- 3) Insert the USB memory into the machine.
  - When the USB memory is not inserted, "INSERT A STORAGEE-MANUAL STORED ON" is displayed. When [OK] button is pressed, the screen shifts to the folder select menu 1.
- 4) Select the folder of the watermark data. (The screen shifts to the watermark data install menu.)  
The current version and the update version are displayed.
- 5) Press [EXECUTE] button.  
[EXECUTE] button is highlighted, and [YES] and [NO] buttons are changed from gray-out to active display.
- 6) When [YES] button is pressed, the selected watermark data are installed.  
When install is completed, "COMPLETE" is displayed. In case of an abnormality, "ERROR" is displayed.

## C. Procedures necessary for SD card replacement

### (1) SD card data and backup

Some SD card storage data can be backed up, and some other cannot. Some SD card storage data can be reinstalled, and some other cannot. If the SD card operates normally before replacement and data can be backed up, back up the data before replacement of the SD card referring to the storage data list. Then reinstall the data after replacement of the SD card.

The SD card includes the following data.

#### SD card backup

##### a. 18cpm/20cpm machine (Option HDD uninstalled)

Partition number	Stored data		Enable/Disable of data backup	Backup means	Enable/Disable of data reinstall	Data reinstall procedures
L-101	ICU firmware data	ICU firmware (Boot/Main) lang.sfu graph.sfu Boot animation Boot (CN) ARM9 firmware	Disable		Enable	SIM49-1 (BOOT cannot be installed again.)
S-101	ICU firmware fixed data (Pre-install)	font	Disable		Enable	SIM49-1
		web help	Disable		Enable	SIM49-1
		spdl	Disable		Enable	SIM49-1
		Option FontROM	Disable		Enable	SIM49-1
S-102	ICU firmware fixed data (Mirror)	Same as above	Disable		Enable	SIM49-1
S-105	System data	Setting value data file (System setting/SIM setting data (Image quality adjustment)/FAX Soft SW)	Disable	SIM56-2	Enable	SIM56-2
S-103	User data	System setting data	Enable	sim56-02	Enable	SIM56-2
		Key operator custom setting data (Data changed from the default)	Enable	System setting - data backup - device cloning	Enable	System setting - data backup - device cloning
		FAX reception data (For power shut off and paper empty)	Disable		Disable	
		FEP learning data (Japanese/Chinese)	Disable		Disable	
		Firmware update data (differential between new and old) (For FSS)	Disable		Disable	
		Account management information/ User authentication data	Enable	sim56-02	Enable	SIM56-2
		Home screen customize data	Enable	System setting - data backup - device cloning	Enable	System setting - data backup - device cloning
		Address Data	Enable	System setting - data backup - storage backup	Enable	System setting - data backup - storage backup
I-101	FAX reception data	FAX/Internet Fax reception image data	Enable	SIM66-62	Disable	
I-102	FAX reception data	FAX/Internet Fax reception image data (Backup)	Enable	SIM66-62	Disable	

- 1) Use SIM56-02 to backup the SD card data to the USB memory.
- 2) When the address book has been registered, use the storage backup function to backup the address book data.
- 3) When the operation panel home screen has been customized, backup the SD card data by using the device cloning function.
- 4) When there are some FAX/Internet Fax data received, use SIM66-62 to backup the image data to the USB memory in the PDF file type, and give the PDF file to the user. (The data cannot be restored to the machine.)
- 5) Replace the SD card with a new one.
- 6) Upgrade the firmware to the latest version.
- 7) Use SIM66-10 to clear the image send memory.
- 8) Use SIM56-02 to restore the data backed up in procedure 1).
- 9) Restore the address book data backed up in the procedure 2). By using the storage backup function.
- 10) Restore the data backed up in procedure 3) by using the device cloning function.

#### Important

When replacing the SD card, be sure to use only the specified SD card supplied as a service part.

**The firmware required for booting must be included in the SD card used in this machine. The commercially available SD cards have no such data.**

#### Note

When U2-40 error occurs, if the error cannot be canceled by SIM16, or when E7-07 error occurs, there may be some trouble in the SD card.

#### Important

The data backed up with SIM56-2 must not be installed to another machine. If installed, the adjustment data will be overwritten and a trouble may be generated.

**b. 18cpm/20cpm (Option HDD installed)/23cpm/26cpm/31cpm/36cpm machine**

Partition number	Stored data		Enable/Disable of data backup	Backup means	Enable/Disable of data reinstall	Data reinstall procedures
L-101	ICU firmware data	ICU firmware (Boot/Main) lang.sfu graph.sfu Boot animation Boot (CN) ARM9 firmware	Disable		Enable	SIM49-1 (BOOT cannot be installed again.)
S-101	ICU firmware fixed data (Pre-install)	font	Disable		Enable	SIM49-1
		web help	Disable		Enable	SIM49-1
		spdl	Disable		Enable	SIM49-1
		Option FontROM	Disable		Enable	SIM49-1
		<b>26cpm/36cpm/31cpm(A) machine</b> UI Action Script main program UI screen information (XML data) Flash image Flash language data Flash guidance animation	Disable		Enable	SIM49-1
S-102	ICU firmware fixed data (Mirror)	Same as above	Disable		Enable	SIM49-1
S-105	System data	Setting value data file (System setting/SIM setting data (Image quality adjustment)/FAX Soft SW)	Disable	SIM56-2	Enable	SIM56-2
S-103	User data	System setting data	Enable	sim56-02	Enable	SIM56-2
		Key operator custom setting data (Data changed from the default)	Enable	System setting - data backup - device cloning	Enable	System setting - data backup - device cloning
		FAX reception data (For power shut off and paper empty)	Disable		Disable	
		FEP learning data (Japanese/Chinese)	Disable		Disable	
		Firmware update data (differential between new and old) (For FSS)	Disable		Disable	
		Account management information/ User authentication data	Enable	sim56-02	Enable	SIM56-2
		Home screen customize data	Enable	System setting - data backup - device cloning	Enable	System setting - data backup - device cloning
I-101	FAX reception data	FAX/Internet Fax reception image data	Enable	SIM66-62	Disable	

- 1) Use SIM56-02 to backup the SD card data to the USB memory.
- 2) When the operation panel home screen has been customized, backup the SD card data by using the device cloning function.
- 3) When there are some FAX/Internet Fax data received, use SIM66-62 to backup the image data to the USB memory in the PDF file type, and give the PDF file to the user. (The data cannot be restored to the machine.)
- 4) Replace the SD card with a new one.
- 5) Upgrade the firmware to the latest version.
- 6) Use SIM66-10 to clear the image send memory. (This is in order to obtain consistency between the HDD data and the image related memory.)
- 7) Use SIM56-02 to restore the data backed up in procedure 1).
- 8) Restore the data backed up in procedure 2) by using the device cloning function.

**Important**

When replacing the SD card, be sure to use only the specified SD card supplied as a service part.

**The firmware required for booting must be included in the SD card used in this machine. The commercially available SD cards have no such data.**

**Note**

When U2-40 error occurs, if the error cannot be canceled by SIM16, or when E7-07 error occurs, there may be some trouble in the SD card.

**Important**

The data backed up with SIM56-2 must not be installed to another machine. If installed, the adjustment data will be overwritten and a trouble may be generated.

### 3. HDD/SD card SIM format operation

The relations between SIM62/66 and formatted (deleted) data are as follows:

- \*1: Physical format ("0" is written to the all area.)
- \*2: Logical format (Only the management area is initialized.)
- \*3: Nothing is done.

#### SIM66-10 FAX image memory clear

HDD

Partition number	Partition	
I-1	ERDH work + Temporary storage	*3
I-2	Document filing data (Standard + User)	*3
I-4	FAX/Internet Fax reception data	*2
L-1	System storage data	*3
L-2	Mirroring information (When the mirroring kit is installed, the mirroring information is written.)	*3
S-1	User data 1	*3
S-10	Pre-install data (e-manual/ Watermark)	*3
S-2	Application #1 (Job log data)	*3
S-3	Redial information of the address book	*3
S-5	Printer spooler	*3
S-6	Application work	*3
S-9	DSK data save	*3

SD Card

Partition number	Partition	
I-101	FAX/Internet Fax reception data	*2
I-102	FAX/Internet Fax reception data (Backup)	*2
L-101	ICU firmware	*3
S-101	ICU firmware fixed data (Pre-install)	*3
S-102	ICU firmware fixed data (Mirror)	*3
S-103	User data 2	*3
S-105	System data (System setting/ SIM setting data (Image quality adjustment)/FAX Soft SW)	*3

#### SIM62-1 Hard disk format

HDD

Partition number	Partition	
I-1	ERDH work + Temporary storage	*1
I-2	Document filing data (Standard + User)	*1
I-4	FAX/Internet Fax reception data	*1
L-1	System storage data	*1
L-2	Mirroring information (When the mirroring kit is installed, the mirroring information is written.)	*3
S-1	User data 1	*1
S-10	Pre-install data (e-manual/ Watermark)	*3
S-2	Application #1 (Job log data)	*1
S-3	User setting information for direct WEB browsing / Cookie file for OSA application	*1
S-5	Printer spooler	*1
S-6	Application work	*1
S-7	eOSA application file	*1
S-8	User file saved in the SMB server (NAS)	*1
S-9	DSK data save	*1

SD Card

Partition number	Partition	
L-101	ICU firmware	*3
S-101	ICU firmware fixed data (Pre-install)	*3
S-102	ICU firmware fixed data (Mirror)	*3
S-105	System data (System setting/ SIM setting data (Image quality adjustment)/FAX Soft SW)	*3
S-103	User data 2	*1
I-101	FAX/Internet Fax reception data	*1

#### SIM62-8 Hard disk format (Excluding the system area)

HDD

Partition number	Partition	
I-1	ERDH work + Temporary storage	*1
I-2	Document filing data (Standard + User)	*1
I-4	FAX/Internet Fax reception data	*1
L-1	System storage data	*3
L-2	Mirroring information (When the mirroring kit is installed, the mirroring information is written.)	*3
S-1	User data 1	*1
S-10	Pre-install data (e-manual/ Watermark)	*3
S-2	Application #1 (Job log data)	*1
S-3	User setting information for direct WEB browsing / Cookie file for OSA application	*1
S-5	Printer spooler	*1
S-6	Application work	*1
S-7	eOSA application file	*1
S-8	User file saved in the SMB server (NAS)	*1
S-9	DSK data save	*1

SD Card

Partition number	Partition	
I-101	FAX/Internet Fax reception data	*1
L-101	ICU firmware	*3
S-101	ICU firmware fixed data (Pre-install)	*3
S-102	ICU firmware fixed data (Mirror)	*3
S-103	User data 2	*1
S-105	System data (System setting/ SIM setting data (Image quality adjustment)/FAX Soft SW)	*3

#### SIM62-10 Job complete list (Job log data) delete

HDD

Partition number	Partition	
I-1	ERDH work + Temporary storage	*3
I-2	Document filing data (Standard + User)	*3
I-4	FAX/Internet Fax reception data	*3
L-1	System storage data	*3
L-2	Mirroring information (When the mirroring kit is installed, the mirroring information is written.)	*3
S-1	User data 1	*3
S-10	Pre-install data (e-manual/ Watermark)	*3
S-2	Application #1 (Job log data)	*2
S-5	Printer spooler	*3
S-6	Application work	*2
S-9	DSK data save	*3

SD Card

Partition number	Partition	
I-101	FAX/Internet Fax reception data	*3
I-102	FAX/Internet Fax reception data (Backup)	*3
L-101	ICU firmware	*3
S-101	ICU firmware fixed data (Pre-install)	*3
S-102	ICU firmware fixed data (Mirror)	*3
S-103	User data 2	*3
S-105	System data (System setting/ SIM setting data (Image quality adjustment)/FAX Soft SW)	*3

**SIM62-11 Document filing data delete**

HDD

Partition number	Partition	
I-1	ERDH work + Temporary storage	*2
I-2	Document filing data (Standard + User)	*2
I-4	FAX/Internet Fax reception data	*3
L-1	System storage data	*3
L-2	Mirroring information (When the mirroring kit is installed, the mirroring information is written.)	*3
S-1	User data 1	*3
S-10	Pre-install data (e-manual/ Watermark)	*3
S-2	Application #1 (Job log data)	*3
S-5	Printer spooler	*2
S-6	Application work	*3
S-9	DSK data save	*3

SD Card

Partition number	Partition	
I-101	FAX/Internet Fax reception data	*3
L-101	ICU firmware	*3
S-101	ICU firmware fixed data (Pre-install)	*3
S-102	ICU firmware fixed data (Mirror)	*3
S-103	User data 2	*3
S-105	System data (System setting/ SIM setting data (Image quality adjustment)/FAX Soft SW)	*3

**SIM62-13 Hard disk format (Manual area only)**

HDD

Partition number	Partition	
I-1	ERDH work + Temporary storage	*3
I-2	Document filing data (Standard + User)	*3
I-4	FAX/Internet Fax reception data	*3
L-1	System storage data	*3
L-2	Mirroring information (When the mirroring kit is installed, the mirroring information is written.)	*3
S-1	User data 1	*3
S-10	Pre-install data (e-manual/ Watermark)	*2
S-2	Application #1 (Job log data)	*3
S-5	Printer spooler	*3
S-6	Application work	*3
S-9	DSK data save	*3

SD Card

Partition number	Partition	
I-101	FAX/Internet Fax reception data	*3
L-101	ICU firmware	*3
S-101	ICU firmware fixed data (Pre-install)	*3
S-102	ICU firmware fixed data (Mirror)	*3
S-103	User data 2	*3
S-105	System data (System setting/ SIM setting data (Image quality adjustment)/FAX Soft SW)	*3

## 4. Necessary works and notes for replacement of the mirroring kit HDD

### Note

#### Terminology and contents

Mirroring information: When the mirroring kit is installed and the power is turned ON, the mirroring information is written into the L-2 partition of the both HDD's.

Rebuilding: Copying operation of the whole contents of one HDD to the other HDD.

Forcible rebuilding: Erasing the mirroring information in the HDD and rewriting new information.

When the mirroring kit is installed, the two HDD's are named HDD1 and HDD2.

HDD1: Mirroring kit HDD

HDD2: Standard HDD for the machine



The status of each HDD can be checked with SIM62-20.

#### Outline / Description Items

Kinds of errors and remedies	A. Causes and remedies when the icon of HDD trouble is displayed
	B. Causes and remedies when the E7-03 error display is popped up
Specified remedies for each error (Details of remedies and procedures)	C. Replacement procedures of the HDD of the mirroring kit or that of the machine
	D. Replacement procedures of both of the HDD of the mirroring kit and that of the machine
	E. Note for reuse of HDD

#### Mirroring kit status and status icons

When the mirroring kit is installed, one of the following icons is displayed on the operation panel.

Icon	Mirroring kit status
	Mirroring kit installed
	Mirroring kit/HDD trouble
	Mirroring kit/Rebuilding

#### A. Causes and remedies when the icon of HDD trouble is displayed

(When the icon shown below is displayed)

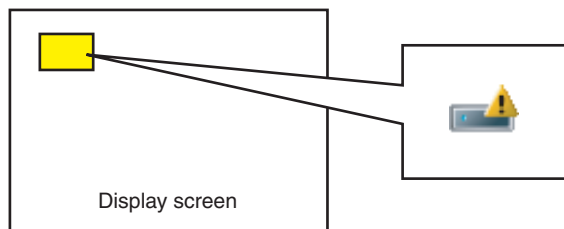

- When one HDD goes into trouble, the UI icon which indicates HDD trouble of the mirroring kit is displayed.
- Use SIM62-20 to check the HDD status, and refer to the table below to confirm the relation between the HDD status and the remedy.

#### SIM62-20 status and causes of troubles (When the icon of HDD trouble is displayed)

		HDD2				
		OK	NONE	REBUILDING	ERROR	TROUBLE
HDD1	OK	–	A	–	A	A
	NONE	A	–	–	–	–
	REBUILDING	–	–	–	–	–
	ERROR	A	–	–	–	–
	TROUBLE	A	–	–	–	–

- Refer to the table below and check to confirm the remedy.

**Table: Causes of troubles and remedies when the icon of HDD trouble is displayed**

Case	State	Cause	Remedy
A	One HDD status is OK. The other HDD status is other than OK.	<ul style="list-style-type: none"> <li>The HDD which indicates the status other than OK is in trouble.</li> <li>Connection failure of the connectors and harness of the mirroring kit</li> </ul>	<ul style="list-style-type: none"> <li>Replace the HDD. (Perform "C. Replacement procedures of the HDD of the mirroring kit or that of the machine")</li> <li>Replace the mirroring kit. (Perform "C. Replacement procedures of the HDD of the mirroring kit or that of the machine")</li> </ul>

- Refer to the details of the remedy and perform the necessary procedures.

## B. Causes and remedies when the E7-03 error display is popped up

- 1) Use SIM62-20 to check the HDD status, and refer to the table below to confirm the relation between the HDD status and the remedy. Refer to the table of "Causes of troubles and remedies when the E7-03 error occurs" and perform the necessary procedures.

Backup the data from the HDD without trouble first.

### SIM62-20 status and causes of troubles

		HDD2				
		OK	NONE	REBUILDING	ERROR	TROUBLE
HDD1	OK	B	B or C	B	B	B
	NONE	B or C	C	C	C	C
	REBUILDING	B	C	F	F	F
	ERROR	B	C	F	F	F
	TROUBLE	B	C	F	F	D or E

- 2) Refer to the table below, and check to confirm the remedy.

### Causes of troubles and remedies when the E7-03 error occurs

Case	State	Cause	Remedy
B	When at least one HDD is OK.	<ul style="list-style-type: none"> <li>Communication trouble through the SATA harness of HDD.</li> <li>Trouble of HDD which indicates the status other than OK.</li> <li>Broken data in HDD</li> <li>The mirroring side HDD is normal. The machine side HDD is in trouble or rebuild operation is not completed.</li> <li>RAID PWB trouble</li> </ul>	<ul style="list-style-type: none"> <li>Replace the cable. Remove and connect.</li> <li>Replace the HDD which indicates other than OK. (Perform procedures of "C. Replacement procedures of the HDD of the mirroring kit or that of the machine.")</li> <li>Replace both of the HDD of the mirroring kit and that of the machine. (Perform procedures of "D. Replacement procedures of both of the HDD of the mirroring kit and that of the machine.")</li> </ul>
C	When at least one HDD is NONE.	<ul style="list-style-type: none"> <li>Communication trouble through the SATA harness of HDD.</li> <li>Connection failure between the RAID PWB and the HDD.</li> <li>HDD trouble</li> <li>HDD SATA harness and connector trouble</li> <li>Both the mirroring side HDD and the machine side HDD are in trouble.</li> <li>RAID PWB trouble</li> </ul>	<ul style="list-style-type: none"> <li>Replace the cable. Remove and connect.</li> <li>Check connection between the mirroring kit and the HDD.</li> <li>Replace the HDD which indicates NONE. (Perform procedures of "C. Replacement procedures of the HDD of the mirroring kit or that of the machine.")</li> <li>Replace the mirroring kit. (Perform procedures of "C. Replacement procedures of the HDD of the mirroring kit or that of the machine.")</li> <li>Replace both of the HDD of the mirroring kit and that of the machine. (Perform procedures of "D. Replacement procedures of both of the HDD of the mirroring kit and that of the machine.")</li> </ul>
D	When in TROUBLE-TROUBLE.	<ul style="list-style-type: none"> <li>RAID PWB trouble</li> <li>(Both or one) HDD trouble</li> <li>Raid PWB is in trouble. The mirroring side HDD is normal. The machine side HDD is other than OK.</li> </ul>	<ul style="list-style-type: none"> <li>Replace the mirroring kit. (Perform procedures of "C. Replacement procedures of the HDD of the mirroring kit or that of the machine.")</li> <li>Replace both of the HDD of the mirroring kit and that of the machine. (Perform procedures of "D. Replacement procedures of both of the HDD of the mirroring kit and that of the machine.")</li> </ul>
E	When in TROUBLE-TROUBLE. (Occurring when replacing the HDD)	<ul style="list-style-type: none"> <li>The mirroring kit is composed of HDD's which have different mirroring information each other. (A HDD which has been used in the mirroring kit of another machine is used.)</li> </ul>	<ul style="list-style-type: none"> <li>Replace both of the HDD of the mirroring kit and that of the machine. (Perform procedures of "D. Replacement procedures of both of the HDD of the mirroring kit and that of the machine.")</li> </ul>

- 3) Refer to the details of the remedy and perform the necessary procedures.

### Causes and remedies when cases B, C, D, and E are not applicable

Case	State	Cause	Remedy
F	Other than cases B, C, D, and E	<ul style="list-style-type: none"> <li>RAID PWB trouble</li> <li>Both HDD's trouble</li> </ul>	<ul style="list-style-type: none"> <li>Replace the mirroring kit. (Perform procedures of "C. Replacement procedures of the HDD of the mirroring kit or that of the machine.")</li> <li>Replace both of the HDD of the mirroring kit and that of the machine. (Perform procedures of "D. Replacement procedures of both of the HDD of the mirroring kit and that of the machine.")</li> </ul>

### C. Replacement procedures of the HDD of the mirroring kit or that of the machine (Details of the remedies and the procedures)

- When replacing the mirroring kit, follow the replacement procedures of the HDD of the mirroring kit only.

#### (1) Work contents and procedures

##### Data backup

###### Note

When E7-03 error code is popped up, procedures of Step 1 and Step 2 are not required.

Step 1	Back up the data in the HDD before replacement. (By servicing) Use SIM56-2, the device cloning, or the storage backup function to save the data. (Back up the data to the PC or a USB memory.) (Data which can be backed up: Address book data, image send registration data, user authentication data)
Step 2	Back up the data in the HDD before replacement. (By the user or by servicing) Back up the data to the PC by Web page. (Data which can be backed up: Document filing data, JOB log data)
Step 3	When there is some received data of FAX and Internet FAX, use SIM66-62 to back up the image data from the SD card to a USB memory. (The backed up image data are in the PDF file type and cannot be returned to the machine.) Give the backed up data to the use.

##### HDD replacement procedures

Procedure	Procedure
Condition	When a new HDD (blank)(*1) (service part) is used.
Step 4	If HDD1 is in trouble, replace the HDD of the mirroring kit. If HDD2 is in trouble, replace the HDD of the machine. (*2)
Step 5	Boot the machine. → Rebuilding is automatically executed. → Check to confirm that E7-03 error (HDD trouble) does not occur, and that the UI icon which indicates rebuilding of the mirroring kit is displayed. Use SIM 62-20 to confirm that the status of the replaced HDD is displayed as REBUILDING.
Step 6	It takes about one hour to complete rebuilding.
Step 7	Check to confirm that the UI icon which indicated installation of the mirroring unit is displayed. Use SIM62-20 to confirm that the HDD status is displayed as HDD1/HDD2=OK/OK.



### D. Replacement procedures of both of the HDD of the mirroring kit and that of the machine (Details of the remedies and the procedures)

#### (1) Work contents and procedures

##### Data backup

Step 1	When there is some received data of FAX and Internet FAX, use SIM66-62 to back up the image data from the SD card to a USB memory. (The backed up image data are in the PDF file type and cannot be returned to the machine.) Give the backed up data to the use.
--------	---

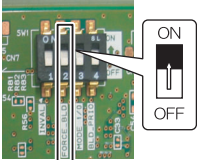
##### HDD replacement procedures

Procedure	Procedure
Condition	When two new HDD's (blank)(*1) (service part) are used for the both.
Step 2	Replace the both HDD's (as well as the RAID PWB if necessary). (*2)
Step 3	Set DIPSW2 of the mirroring kit to ON, and turn on the main power of the machine. → Forcible rebuilding is executed. → Check to confirm that the E7-03 error (HDD trouble) does not occur and that the UI icon which indicates installation of the mirroring kit is displayed. Use SIM62-20 to confirm that the HDD status is displayed as HDD1/HDD2=OK/OK. 
Step 4	Turn OFF the main power of the machine, and set DIPSW2 to OFF. Then, turn ON the main power of the machine again. 
Step 5	Use SIM66-10 to clear the FAX image memory. The memory is cleared in order to ensure consistency between the HDD data and the image memory and to prevent against malfunctions. (Not only the FAX model, but also the scanner and the Internet FAX models require memory clearing.)
Step 6	Use SIM49-3 to install the e-Operation Manual data to the HDD.
Step 7	The trouble code "U2-60" is displayed. → Use SIM49-5 to install the watermark data to the HDD. → Use SIM16 to cancel the U2-60 error.

#### E. Note for reuse of HDD

When replacing the HDD for the mirroring kit, be sure to use a new HDD.

If a HDD which has been used in a mirroring kit is used for replacing the HDD, the operations and the data cannot be assured.

If a HDD which has been used in a mirroring kit is installed, the original data may be erased.

If, however, the mirroring information of the HDD is erased by RIB Buster as described later, it can be used. (\*1) In addition, if the both HDD's are replaced with HDD's which have been used, SIM62-1 must be executed to format HDD's in addition to erasing the mirroring information.

When removing the HDD after installing the mirroring kit, be sure to remove the both HDD's together.

If only one HDD is removed then it is reinstalled, the data of both HDD's may not be identical, causing an error.

When removing the HDD and performing some work, first disconnect the HDD SATA connector of the MFP PWB and perform the work.

With the above procedure, the both HDD's are brought into the status disconnected from the machine.

Put mark on the mirroring kit HDD and the machine HDD to indicate that they have been used. (\*2)

\*1: Refer to "5-C. Deleting the HDD mirroring information."

\*2: Refer to "5-B. How to check the usage history of a HDD in a mirroring kit."



## 5. Note for installing and repairing the mirroring kit

When installing or repairing the mirroring kit, fully understand the following descriptions to avoid erroneous handling and procedures. When a HDD which has once been used for the mirroring kit is reused without proper preparation, it may cause an error and destruction of user data, or other troubles.

The following three cases must be strictly avoided.

- When newly installing a mirroring kit, do not use one which has been once used.
- When replacing the HDD because of a HDD trouble, do not replace it with a HDD which has been once used in a mirroring kit.
- When replacing the HDD because of a HDD trouble in the machine, do not replace it with a HDD which has been once used in a mirroring kit.

### Note

When a HDD is once used in a mirroring kit, the mirroring information is written into the HDD. This causes a trouble by erroneous using.

The details of inhibited items, results of erroneous procedures, and precautions for avoiding those errors are described below.

### A. Details of inhibited items

#### (1) When newly installing a mirroring kit, do not use one which has been once used.

##### Trouble contents

If HDD1 which has been once used is used for new installation of a mirroring kit, the data in HDD1 will be written into HDD2. This causes erasure of the original user data, freeze of the machine, or other troubles. The "HDD which has been once used" includes a HDD which was just installed and conducted only.

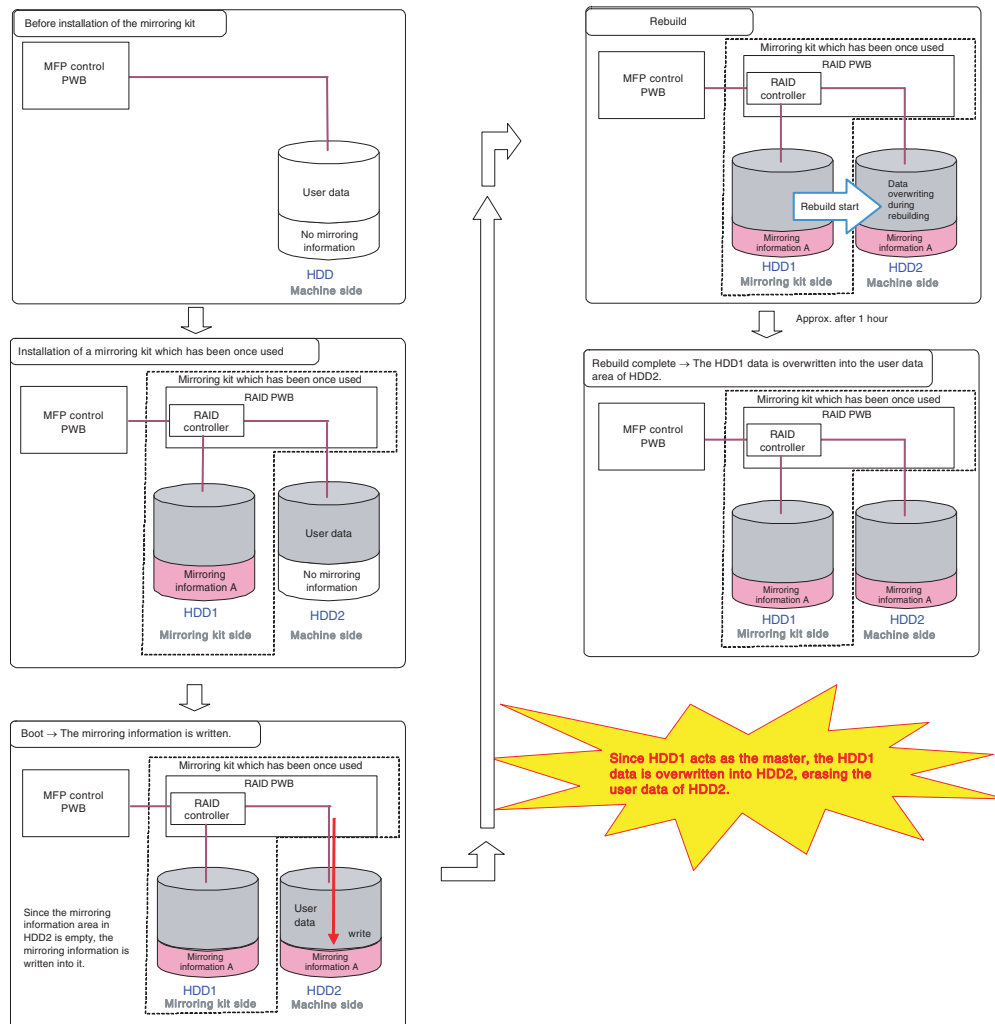

##### Countermeasures

Use a new mirroring kit for installation.

If there is no choice but to use a mirroring kit which has been once used, be sure to erase the mirroring information in the HDD before installation. (For details, refer to "5-C. Deleting the HDD mirroring information.")

**(2) When replacing the HDD in case of a trouble in the HDD, do not use a HDD which has been used in another mirroring kit of another machine.**

**Trouble contents**

If a HDD which has been used in another mirroring kit, the RAID controller cannot recognize the HDD, causing E7-03 error, and the necessary data may be destructed in some cases.

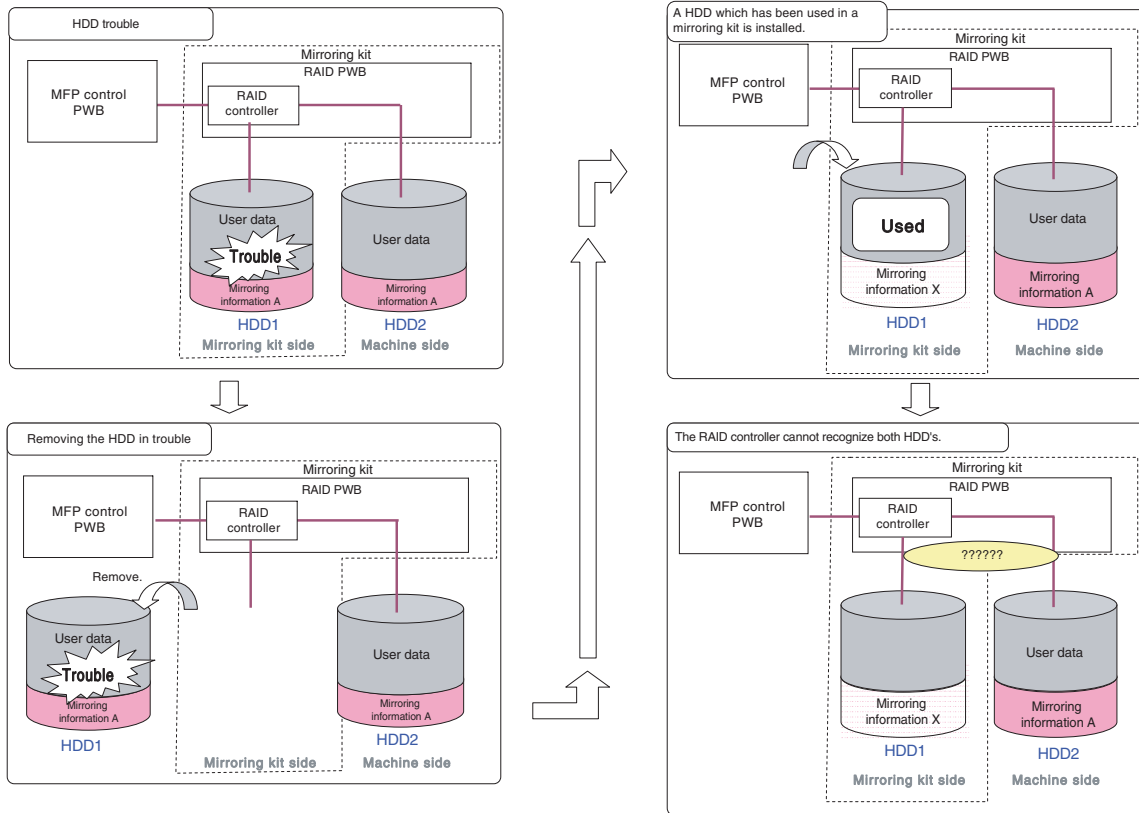

Since the mirroring information of both HDD's does not synchronize each other, the RAID controller cannot recognize both HDD's.  
 → E7-03 error occurs.  
 The user data may be erased and the machine may freeze in some cases.

**Countermeasures**

Use a new mirroring kit for installation.

If there is no choice but to use a mirroring kit which has been once used, be sure to erase the mirroring information in the HDD before installation. (For details, refer to "5-C. Deleting the HDD mirroring information.")

**(3) When the HDD is replaced because of a HDD trouble, do not use a HDD which has been used in a mirroring kit of another machine.**

**Trouble contents**

**In the case of a machine produced before March/2011**

If a HDD which has been used in another mirroring kit is installed, the operation and the data safety cannot be assured. If a HDD which has been used in another mirroring kit is installed, the original data may be erased.

**Support from production of May/2011.**

E7-A5 error occurs. If a HDD which has been used in a mirroring kit is used as the machine HDD, the machine does not operate normally.

In this case, the trouble of erasing the original data is avoided.

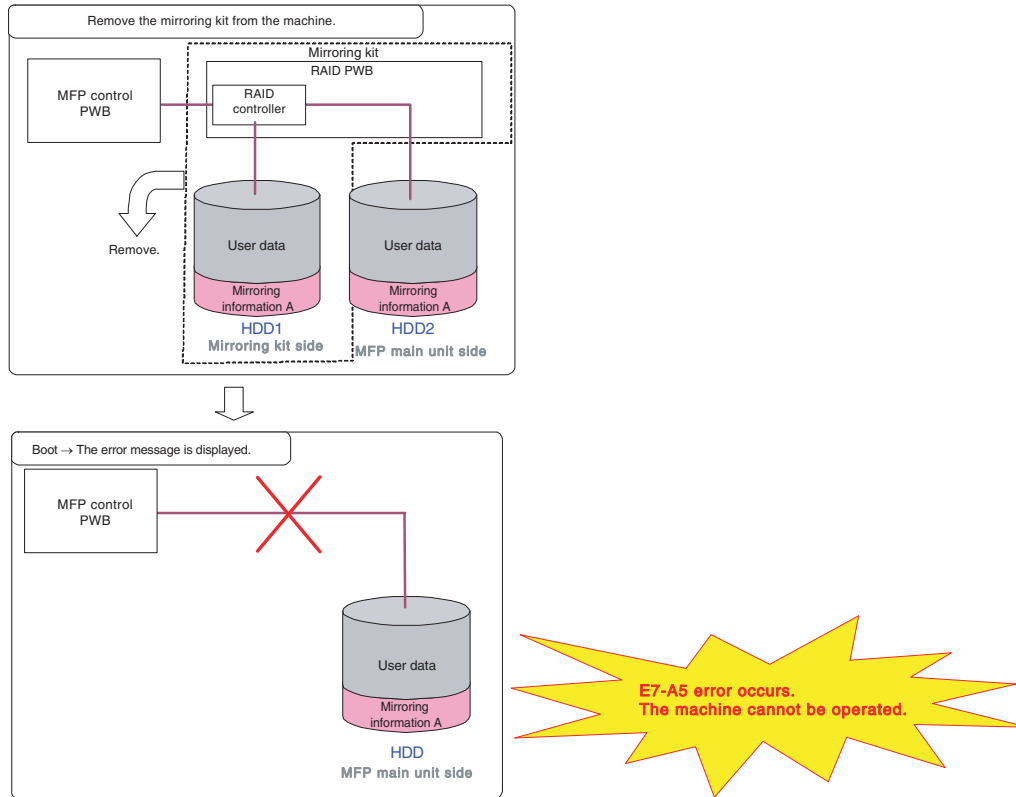

**Countermeasures**

Use a new mirroring kit for installation.

If there is no choice but to use a mirroring kit which has been once used, be sure to erase the mirroring information in the HDD before installation. (For details, refer to "5-C. Deleting the HDD mirroring information.")

When a HDD is used without any other HDD, the mirroring information must be erased before executing SIM62-1 to format.

This procedure allows the HDD being treated as a new HDD.

When removing the HDD after installation of the mirroring kit, remove both HDD's simultaneously. If only one HDD is removed and then installed again, the data of both HDD's may not match, causing a trouble.

[Simultaneous removal of both HDD's] Disconnect the HDD SATA connector of the MFP PWB, and both HDD's are brought into disconnected state from the machine.

## B. How to check the usage history of a HDD in a mirroring kit

As stated before, when installing a mirroring kit or replacing a HDD, be sure to check the usage history of a HDD or a mirroring kit which is to be used.

For convenience of checking the usage history, put a mark on the mirroring kit HDD and the machine HDD when installing them to indicate that they have been used.



## C. Deleting the HDD mirroring information

By deleting the HDD mirroring information, the HDD can be used under the mirroring kit environment.

### (1) Necessary tools

- RIB Buster software
  - The software is composed of the following two files. (They can be downloaded from Tech DS Web site.)
    - RIB Buster{YYYYMMDD}.exe
    - Setup.ini
- Commercially available USB HDD case unit (SATA support)

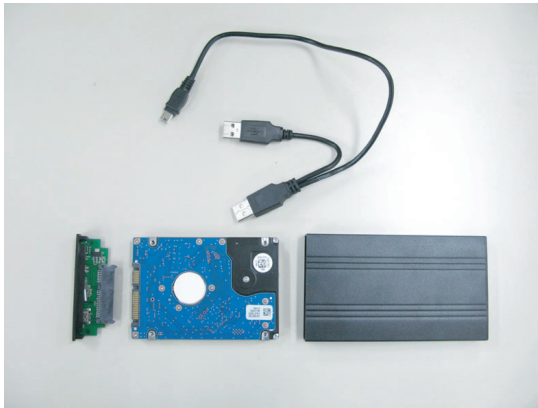

- USB cable
- Windows PC
  - (Support OS: Windows XP, Windows VISTA, Windows 7 (32/64bit))

### (2) Procedures

- 1) Assemble the HDD (the mirroring information of which is to be deleted) to the USB HDD case unit (SATA support), and connect the USB cable.



### Important

When removing or attaching a HDD to the HDD case, be sure to disconnect the USB cable from the PC in advance.

If this precaution is ignored, the HDD may be damaged.

- 2) Copy the RIB Buster software files (RIB Buster {YYYYM-MDD}.exe and Setup.ini) to a same directory of the PC.
  - RIB Buster{YYYYMMDD}.exe
  - Setup.ini
- 3) Connect the PC and the USB HDD case unit assembled in procedure 1) with the USB cable.

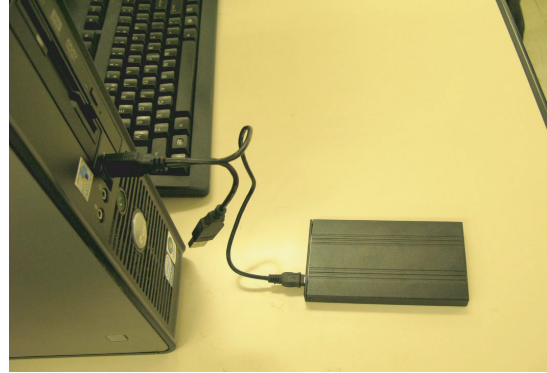

- 4) Double-click RIB Buster {YYYYMMDD}.exe to boot the RIB Buster software.

If the user account control is ON in VISTA or Windows 7 setting, the user account control menu is displayed. Click [Allow] on this menu.

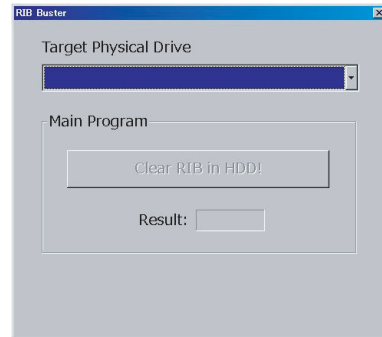

- 5) Select the target HDD to delete the mirroring information.

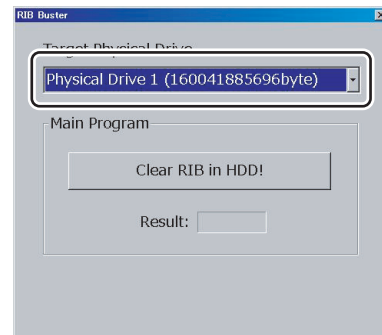

6) Click [Clear RIB in HDD] button.

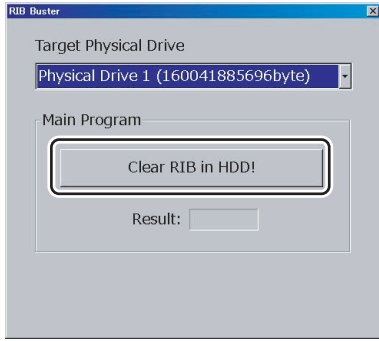

7) Click [OK] button. (The mirroring information is deleted.)

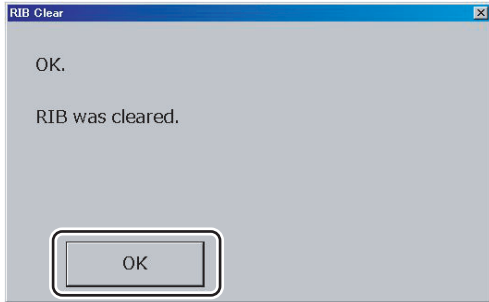

8) After completion of deleting the mirroring information, "OK" is displayed.

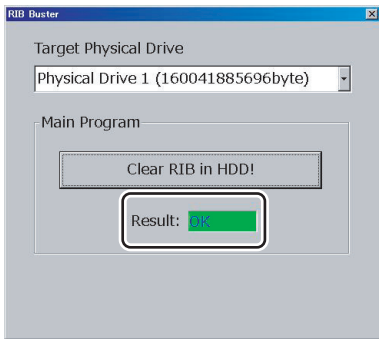

### (3) Kinds of errors, causes and remedies

#### Phenomenon 1

An error indicating an abnormality in the Setup.ini file when booting the RIB Buster software.

Cause	Setup.ini file does not exist, or there is any abnormality in the file.
Countermeasures	Check to confirm that there is Setup.ini file in the proper directory and that there is no abnormality in the descriptions.

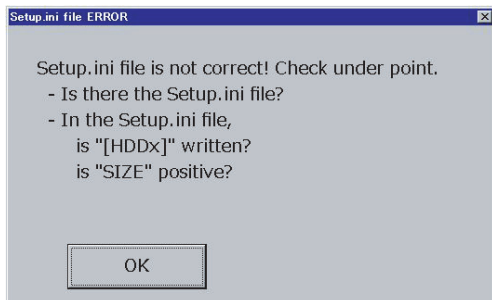

#### Phenomenon 2

The mirroring information has not been deleted normally.

Cause	Temporary communication trouble, cable or other device trouble, HDD trouble
Countermeasures	1. Click [Clear RIB in HDD] button again. 2. If the trouble is not solved by procedure 1. , disconnect and connect the cable, change the devices, and reboot the RIB Buster. Then execute procedure 1. .

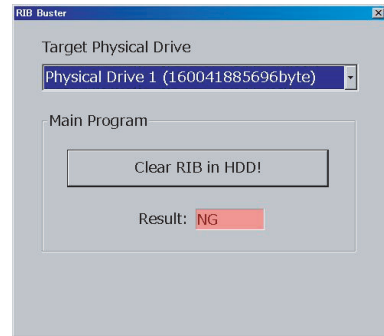
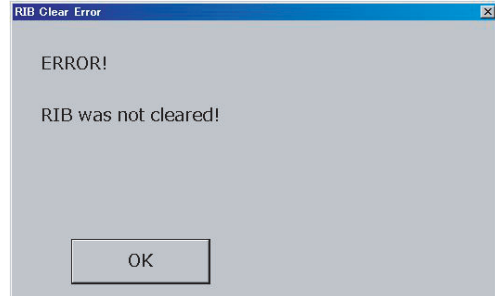

#### Phenomenon 3

Though the target HDD is connected, it is not displayed.

Cause	The target HDD is not registered in the Setup.ini file. Cable or other device trouble, HDD trouble
Countermeasures	1. Reboot RIB Buster, and click the frame section. 2. If the trouble is not solved by procedure 1. , replace the Setup. ini file and the RIB Buster (YYYYMMDD) with the latest version, and execute procedure 1. . 3. If the trouble is not solved by procedure 2. , disconnect and connect the cable, change the devices, and reboot the RIB Buster. Then execute procedure 1. .

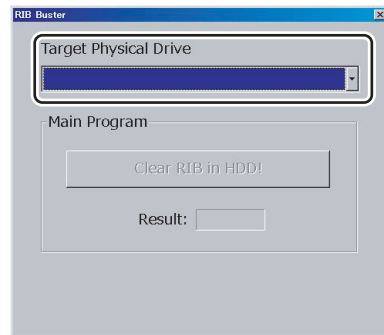

# [11] SERVICE WEB PAGE

## 1. General

The following functions are available on the Hidden Web Page exclusively used for the serviceman.

Menu/Item		Function and content
Password Setting		Used to set the password to enter the Hidden Web Page exclusively used for the serviceman.
Output of Test Page		Used to print out the test page (system setting contents).
Font/Form Download		Used to download Font/Form. Font/Form of PCL and PostScript, macro, and other resources are downloaded to the HDD and controlled. (PS, PCL5 only)
Device Cloning		Used to import/export the system setting information in XML format. By importing the export file to the other device, the setting values and setting contents of the device can be copied to another device. This function is useful to set the same settings to two or more machines efficiently.
Filing Data Backup		Used to import/export the document filing data in the unit of folder.
User Control		Used to shift to the user mode. After log in, the screen is shifted to the setting screen of user management.
User Control 2		Used to set the Pages Limit Group and the Favorite Operation Group by authority of the serviceman. (Select among preset items.)
Job Log	Save Job Log	Used to save the Job Log.
	View Job Log	Used to display the Job Log.
Update of Firmware		Used to update the firmware version.
Syslog*1	Administration Settings	Used to set the Log Type. (Set to the default.)
	Storage/Send Settings	Keep all the items selected.
	Save/ Delete Syslog	Used to save or delete the log data.
	View Syslog	Used to display the log data.

\*1: This may be useful for troubleshooting when a trouble occurs. When submission of the log data file is requested in order to troubleshoot, use the log file save mode to export the log data file to the client PC.

## 2. Details and operation procedures

### A. Procedures to enter the Hidden Web page exclusively used for the serviceman

- 1) Boot a browser program.
- 2) Enter the specified URL ([http://xxx.xxx.xxx.xxx/service\\_login.html](http://xxx.xxx.xxx.xxx/service_login.html)) and enter the servicing page menu.  
Default password: "service"

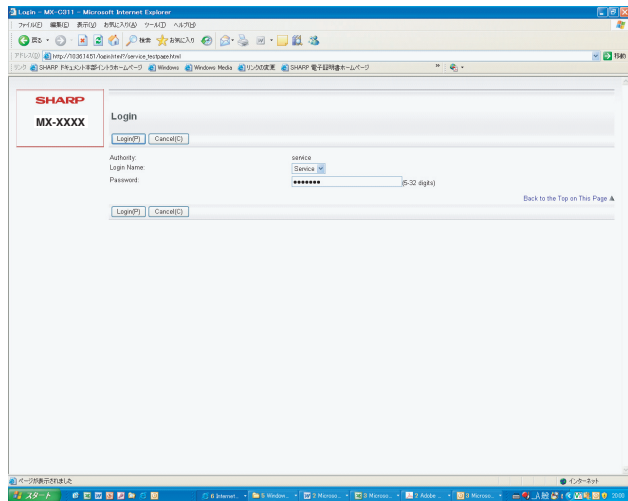

### Note

The password can be optionally changed in the Password Setting menu.

If the password is changed and forgotten, use SIM24-31 to reset the password to the default.

### B. Password Setting

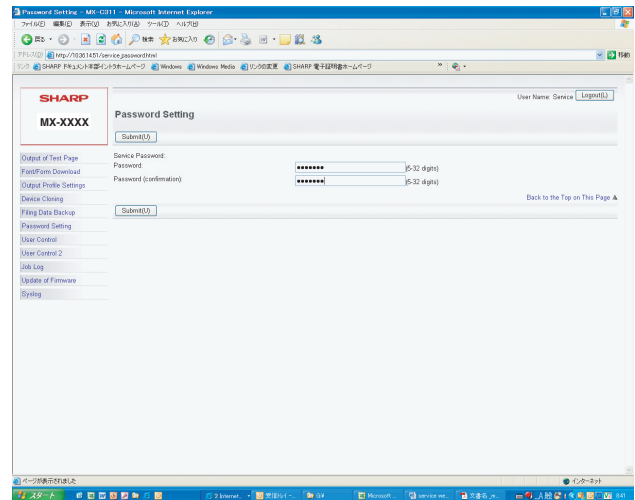

\* The password can be optionally changed in the following procedures.

- 1) Enter a new password.
- 2) Enter the new password again to make confirmation.
- 3) Click "Submit" (registration) button.

## C. Output of Test Page

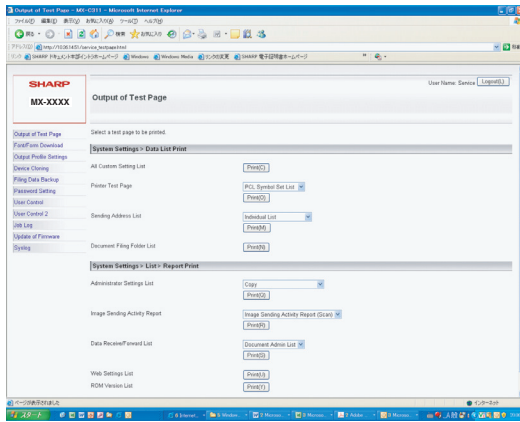

- 1) Click "Print" button of an item or report to be printed. When there is a list of items for selection, select one of the items in the pull-down menu list, and click "Print" button. The list is printed out.

## D. Font/Form Download

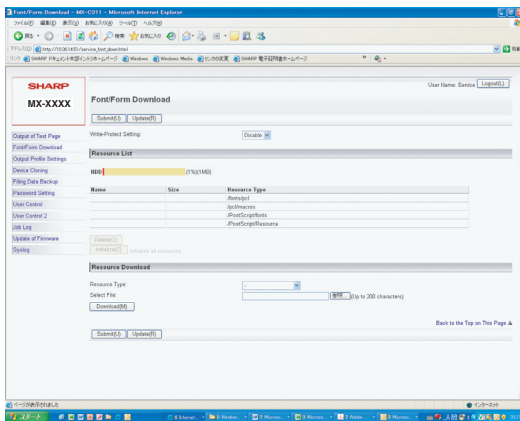

- (1) **Download of Font, Form, and Macro**
  - 1) Select "Resource Type" from the pull-down menu list. (Example: PCL/PostScript Font/Form or Macro)
  - 2) Click "Refer" button to select a target file.
  - 3) Click "Download" button.
  - 4) Click "Submit" (registration) button. The file is downloaded to the HDD. The list of the downloaded files and the use percentage of the HDD are displayed.
- (2) **Delete of downloaded font (Procedures to delete a file separately)**
  - 1) Select a file to be deleted from the list of the downloaded files, and click "Delete" button.
  - 2) Check that the confirmation message is displayed, and press Yes key.
  - 3) Click "Submit" (registration) button. The file in the HDD is deleted.
- (3) **Procedures to delete all the files at a time**
  - 1) Click "Initialize" button.
  - 2) Check that the confirmation message is displayed, and press OK key.
  - 3) Click "Submit" (registration) button.

### Note

By the Write-Protect Setting function, the downloaded files can be set to write protect.

## E. Device Cloning

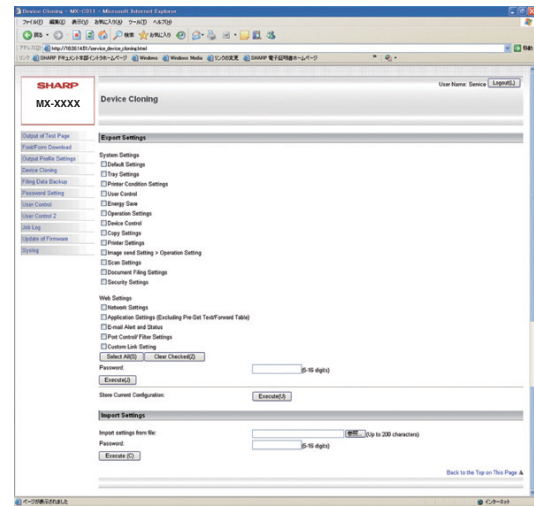

- (1) **Export**
  - 1) Select an item to be backed up.
  - 2) Click "Execute" button. Specify the save position of the file, and save the file. (File name: \*\*\*\*\*.bin) When the password is set, the set password must be entered when importing.
- (2) **Import**
  - 1) Import from a file: Click "Refer" button to select the back-up file. (File name: \*\*\*\*\*.bin)
  - 2) Click "Execute" button to execute import. If the password is set when exporting, the password must be entered.
  - 3) Reboot the machine.

## F. Filing Data Backup

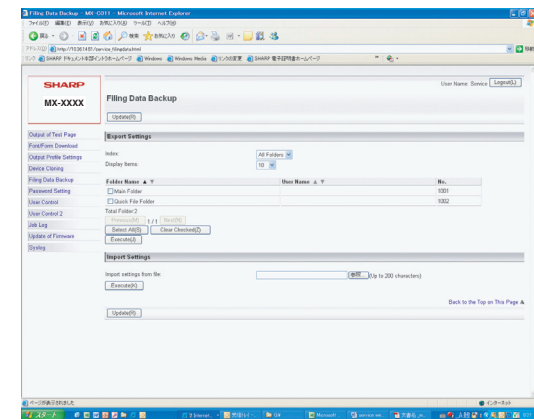

- (1) **Export**
  - 1) Select the folder to be backed up. The list display conditions can be specified by changing the index and the number of display items on the pull-down menu.
  - 2) Click "Execute" button. Specify the save position of the file, and save the file. (File name: \*\*\*\*\*.bin)
  - 3) Click "Update" button.
- (2) **Import**
  - 1) Click "Refer" button to select a target file. (File name: \*\*\*\*\*.bin)
  - 2) Click "Execute" button. The target file is imported.
  - 3) Click "Update" button.

## G. User Control 1

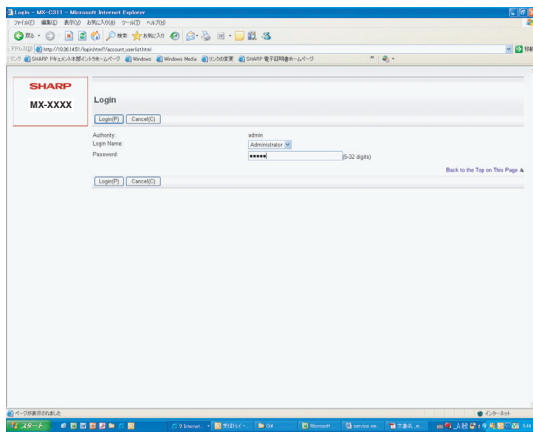

- 1) Enter the password to log in.  
Default Password: admin  
The screen is shifted to the setting menu of user management.

## H. User Control 2

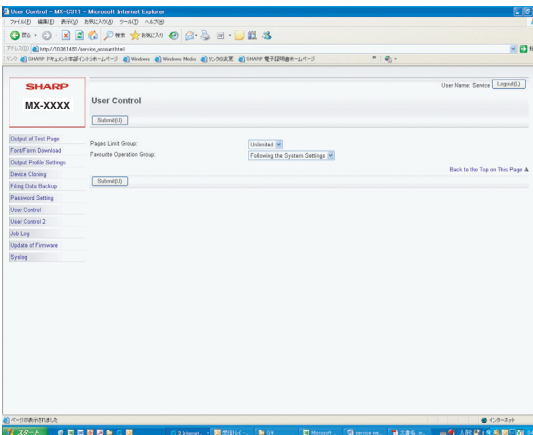

- 1) Select the Pages Limit Group and the Favorite Operation Group. (The Pages Limit Group and the Favorite Operation Group must be set in advance.)

### (Example of use)

The user sets the conditions for servicing work by using the Pages Limit Group and the Favorite Operation Group functions in advance, and the serviceman selects the set conditions in this mode for servicing work.

## I. Job Log

### (1) Save Job Log

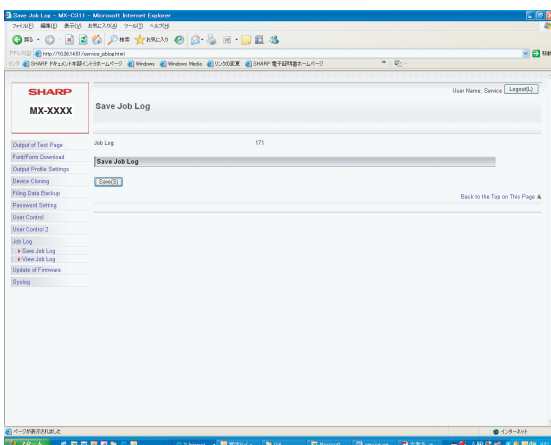

- 1) Click "Save" button, and specify the save position of the Job Log to save it.

### (2) View Job Log

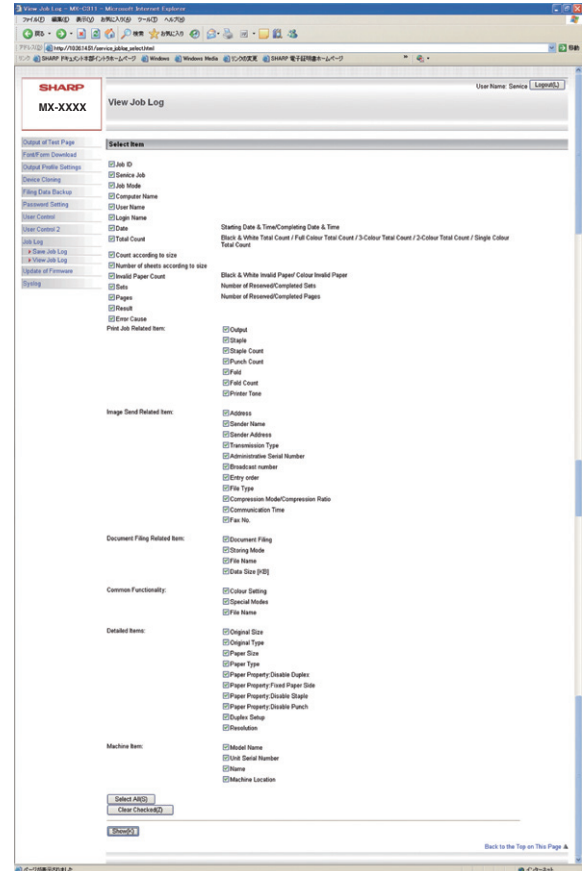

- 1) Select a Jog Log item to be displayed. (In the default setting, all the items are selected. Remove check marks of the items which are not to be displayed.)
- 2) Click "Show" (display) button.  
The Jog Log is displayed.

## J. Update of Firmware

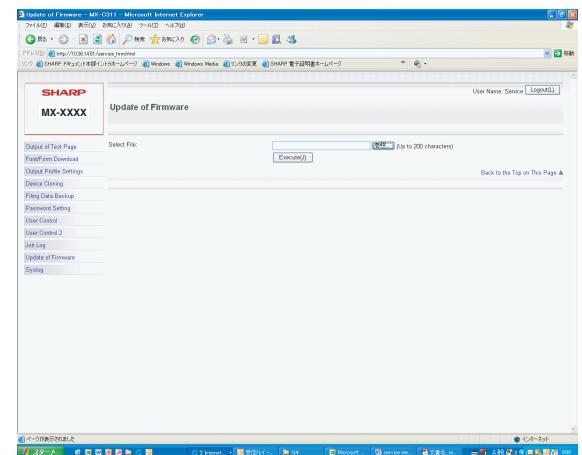

- 1) Click "Refer" button to select a firmware file.
- 2) After selecting a firmware file, click "Execute" button.  
The firmware data are sent to the machine, and update of the firmware is processed.  
During the process, the message of "Firmware Update, now processing..." is displayed.



## K. Syslog

There are following functions in the Syslog mode.

This function is provided to acquire the detailed Syslog to troubleshoot when a trouble occurs.

When submission of the log data file is requested for troubleshooting, use the log file save mode to export the log data file to the client PC.

Syslog	Administration Settings	Log Type Setting (Set to the default.)
	Storage/Send Settings	Set all the items selected.
	Save/ Delete Syslog	Log data save, delete
	View Syslog	Log data display

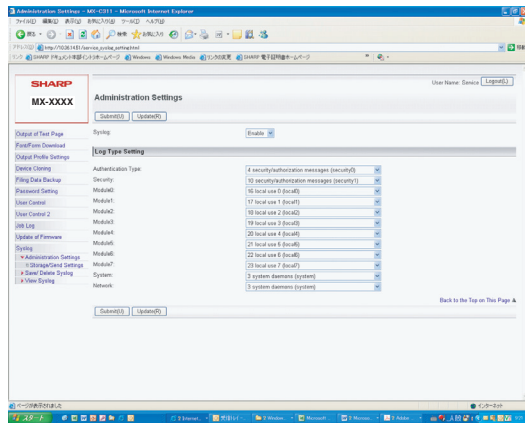

### (1) Administration Settings/ Log Type Setting

Set to the default.

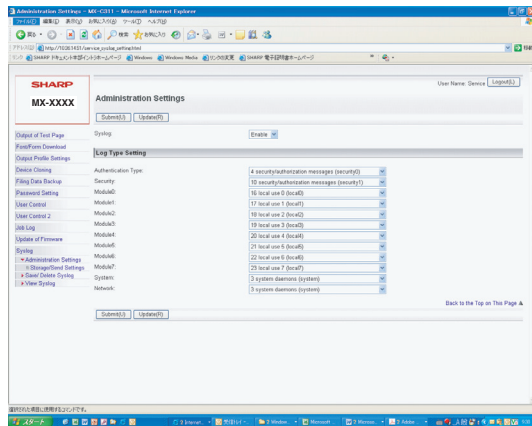

### (2) Storage/Send Settings

Keep all the items selected.

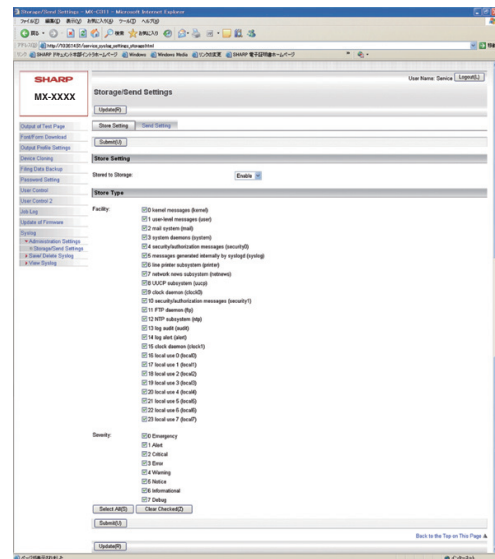

### (3) Save/ Delete Syslog

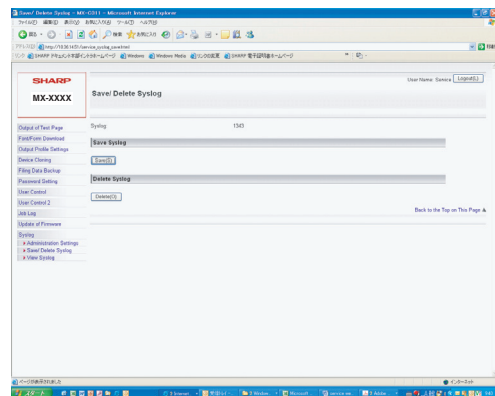

When saving the Syslog, click "Save" button and specify the save position and save it.

When deleting, click "Delete" button.

Check to confirm that the confirmation message is displayed, and press OK key.

### (4) View Syslog

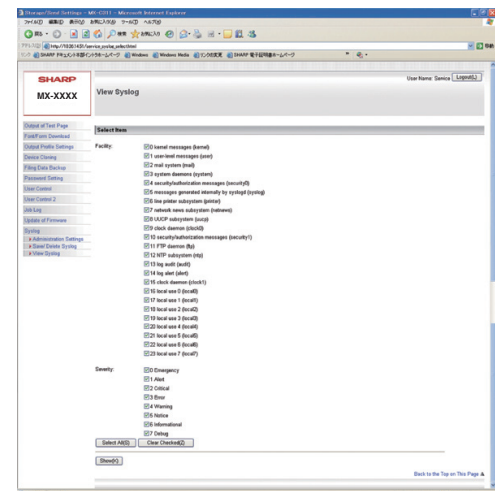

1) Select a Syslog item to be displayed.

2) Click "Show" button.

The Syslog is displayed.

## L. Output Profile Settings

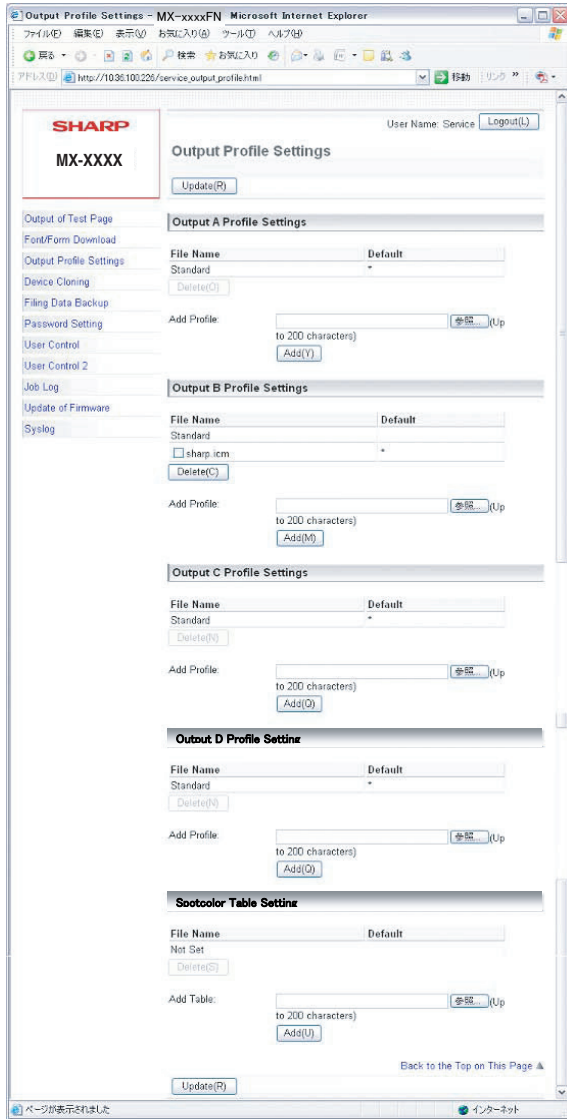

### (1) Download procedures of custom output profile

- 1) Click "Refer" button to select the output profile.
- 2) Click "Add" button to add the output profile.
- 3) Click "Add" button to add the output profile.

The added profile is displayed on the list. For the output A profile and the output B profile, the newly added profile becomes valid.

When no profile is added, the default output profile in the firmware of the machine set when shipping from the factory is valid.

Output A profile / Output B profile / Output D profile: Selectively used.

Output C profile: PS mode, for CMYK simulation (Custom)

Spot Color Table: For PS mode

### (2) Procedures to delete the custom output profile and return to the default output profile

- 1) Click "Delete" button of the output profile to be deleted.
- 2) Click "Update" button.

The custom output profile is deleted and the default output profile in the firmware of the machine becomes valid.

## M. Machine ID Setting

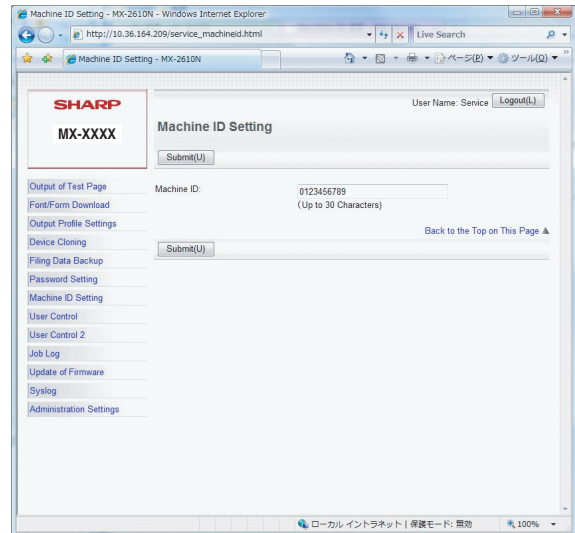

- 1) Enter the machine ID.  
Max. 30 digits of numeral figures and characters can be entered.
- 2) Press the registration button.

### Note

The machine ID can be set with SIM26-7 as well as this function.

## N. Administration Settings (Menu display setting)

This setting is to select whether to display all the menus of Web Page on the machine display or to display only the restricted system setting menu of the default.

Setting must be executed according to the user request.

- 1) Press the setting execution button corresponding to the display mode.

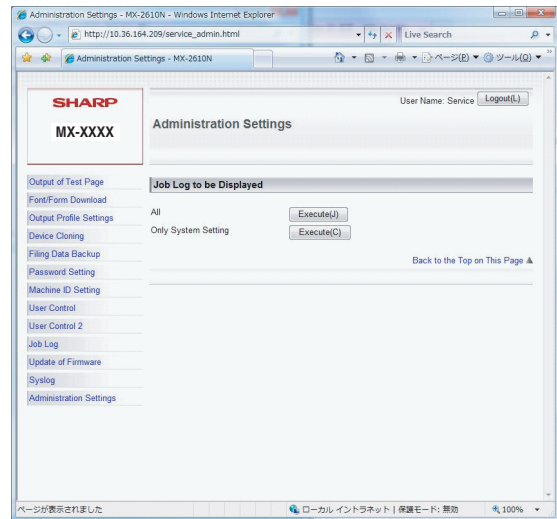

## O. FSS (Field Support System) Setting

- 1) Set the following items.
  - Use Proxy Server: Yes/No
  - Setting of Scheduled Polling: Allow/Inhibit
  - Interval of Scheduled Polling: 1 - 60 min
  - Setting of Manual Polling: Allow/Inhibit
  - Status Notification: On/Off
- 2) Click the Submit (Registration) button.

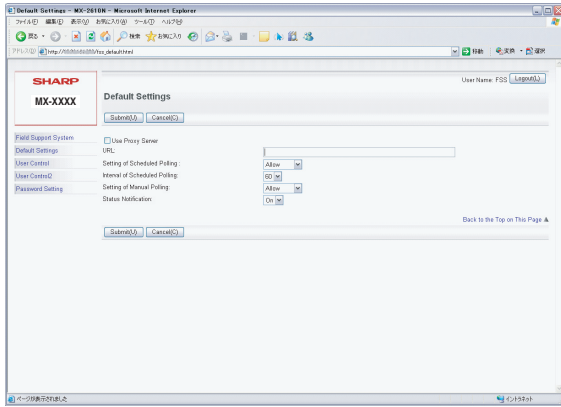

# [12] OPERATIONAL DESCRIPTIONS

## 1. Operation panel section

### A. Electrical and mechanism relation diagram

#### (1) 18cpm/20cpm/23cpm/31cpm(G) machine

##### a. 18cpm machine

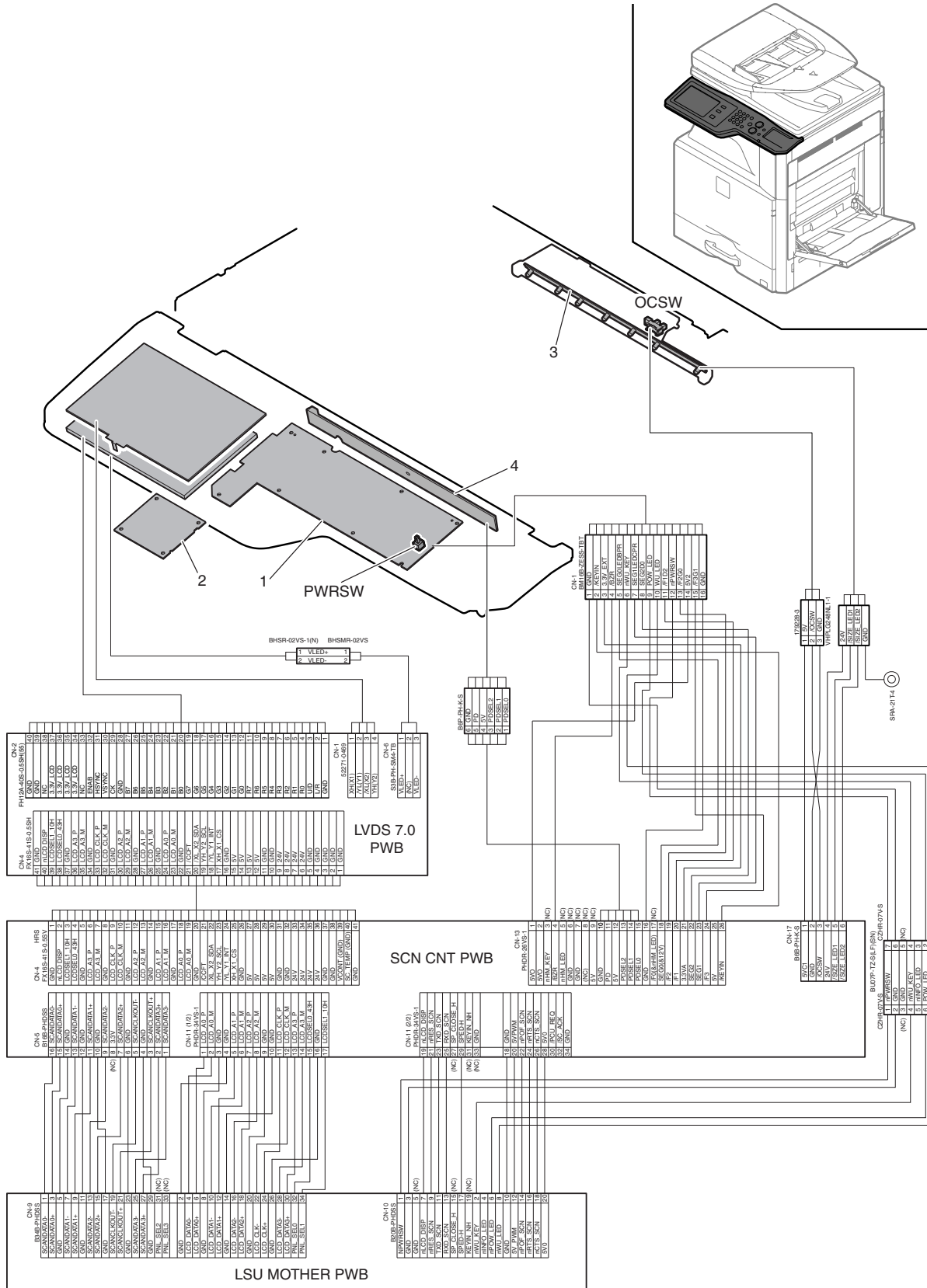

b. 20cpm/23cpm/31cpm(G) machine

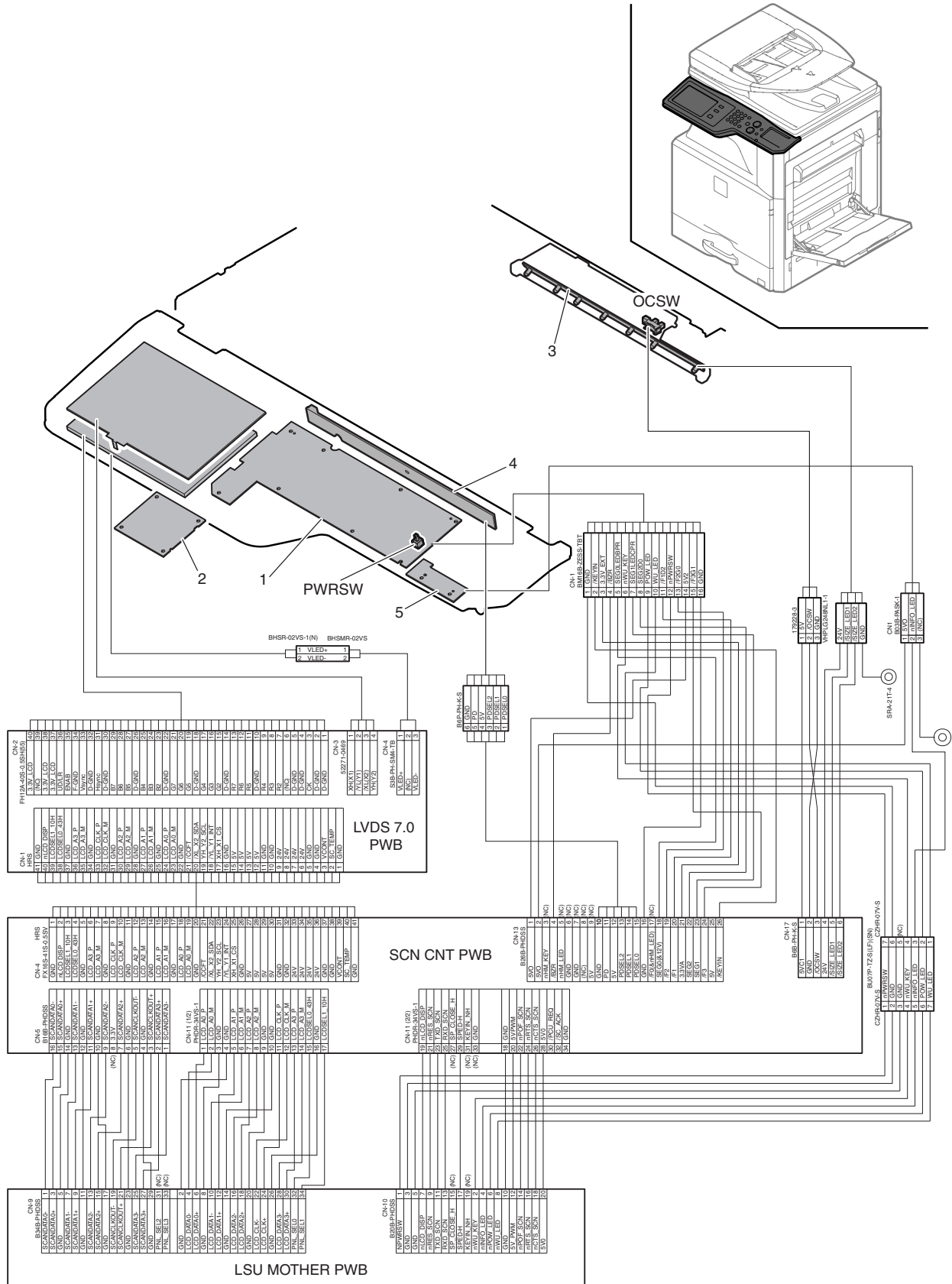

Signal name	Name	Function/Operation
OCSW	Paper size detection trigger sensor	Generates the document size detection trigger signal.
PWRSW	Operation panel power switch	Turns ON/OFF the power on the secondary side.

No.	Name	Function/Operation
1	KEY PWB	Outputs the key operation signal.
2	LVDS PWB	Converts the display data signal to the LCD display signal. / Controls the touch panel.
3	Document size detection PWB (Light emitting)	Drives the LED for the document size detection.
4	Document size detection PWB (Light receiving)	Outputs the document size detection signal.
5	USB I/F PWB	USB Interface

(2) 26cpm/36cpm/31cpm(A) machine

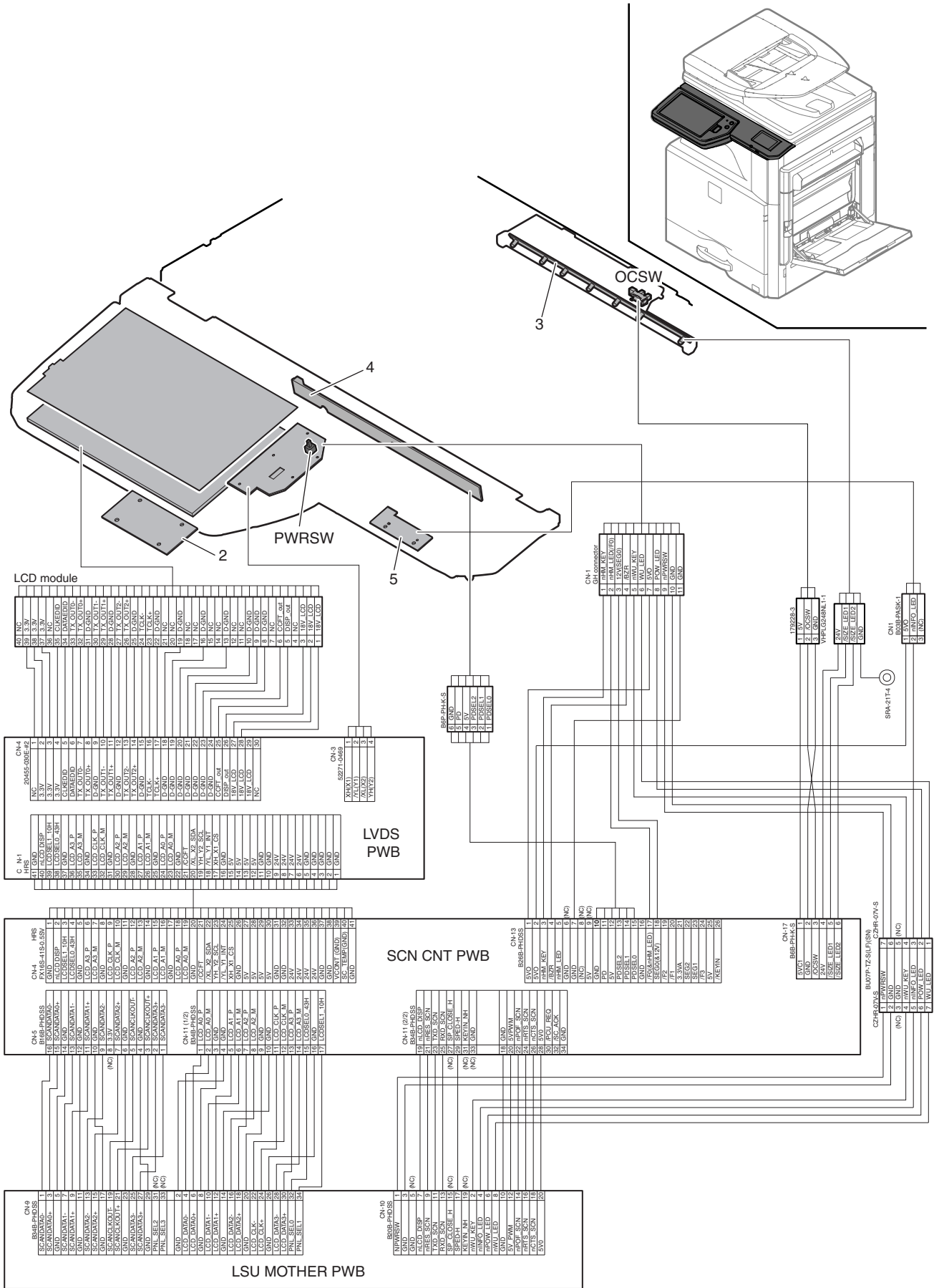

Signal name	Name	Function/Operation
OCSW	Paper size detection trigger sensor	Generates the document size detection trigger signal.
PWRSW	Operation panel power switch	Turns ON/OFF the power on the secondary side.

No.	Name	Function/Operation
1	KEY PWB	Outputs the key operation signal.
2	LVDS PWB	Converts the display data signal to the LCD display signal. / Controls the touch panel.
3	Document size detection PWB (Light emitting)	Drives the LED for the document size detection.
4	Document size detection PWB (Light receiving)	Outputs the document size detection signal.
5	USB I/F PWB	USB Interface

## B. Operational descriptions

The operation panel unit is composed of the LCD unit, the LVDS PWB, the USB I/F PWB, and the KEY PWB. It displays the machine operation. It is provided with the USB I/F which is used for the firmware update, USB print, and Scan to USB.

In addition, the USB I/F line is provided inside the operation panel to connect with the keyboard and the IC card reader.

A document size is detected by the document size detection PWB (light emitting) and the document size detection PWB (light receiving).

The detection timing of document size is determined according to the document size detection trigger sensor signal.



## 2. Scanner section

### A. Electrical and mechanism relation diagram

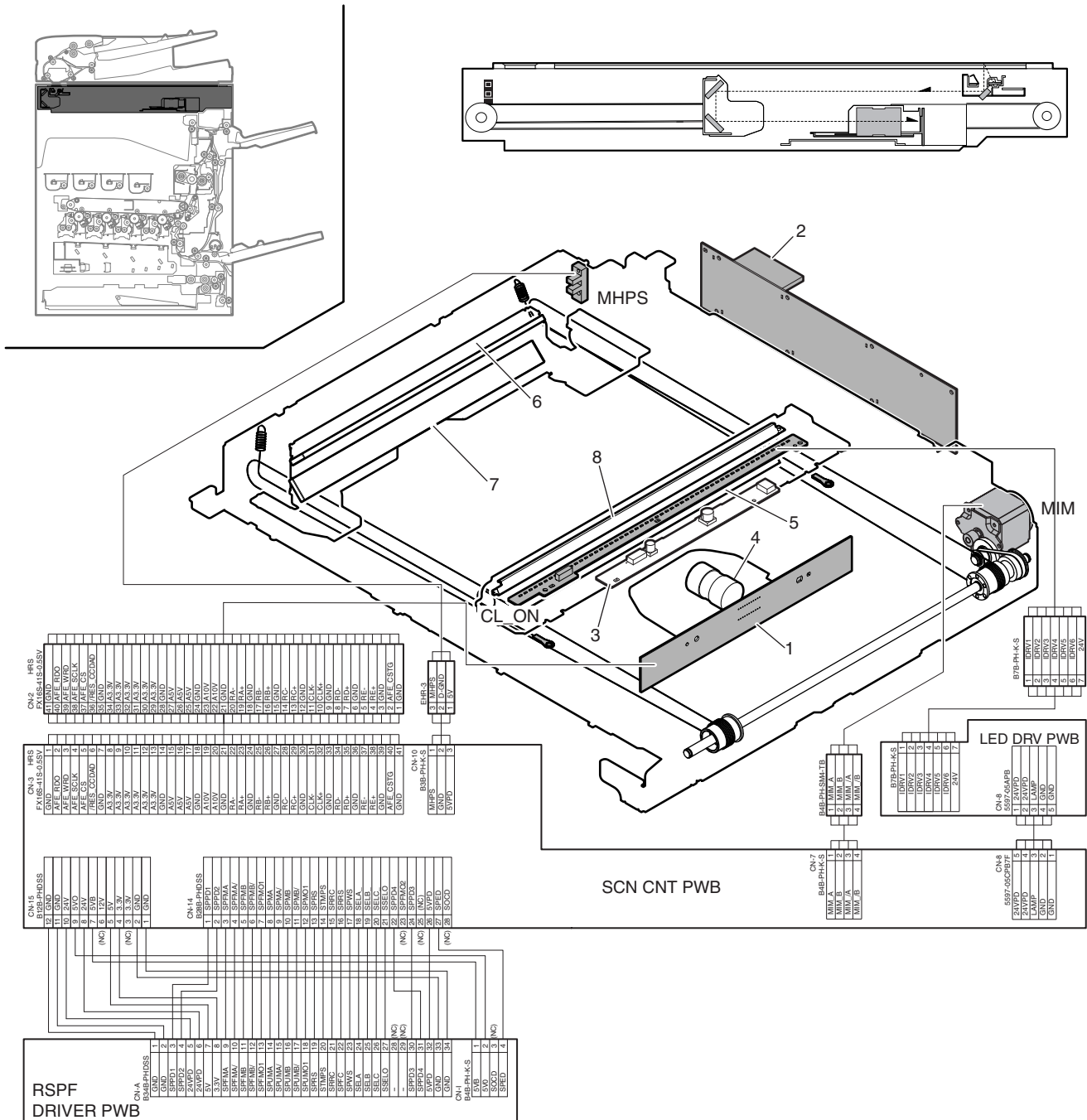

Signal name	Name	Function/Operation
CL_ON	Scanner lamp	Radiates light onto a document for the CCD to scan the document image.
MHPS	Scanner home position sensor	Detects the scanner home position.
MIM	Scan motor	Drives the scanner unit. (scan, return operations)

No.	Name	Function/Operation
1	CCD PWB	Scans document images and performs A/D conversion of the scanning signal.
2	SCU PWB	Controls the scanner and the operation section.
3	Scanner lamp drive PWB	Drives the scanner lamp
4	Lens	Reduces a document image (light) and project it to the CCD.
5	1st mirror	Leads a document image to the lens.
6	2nd mirror	
7	3rd mirror	
8	Reflector	Converges the scanner lamp lights and radiates onto the document.

## B. Operational descriptions

### (1) General

This section performs the following operations.

- 1) Light is radiated onto the document by the scanner lamp and the reflected image is scanned by the 3-line (RGB) CCD elements to be converted into analog image signals.
- 2) The analog image signals are converted into 10-bit digital signals by the A/D converter.
- 3) The digital image signals are sent to the scanner control PWB for image processing.

### (2) Detailed descriptions

#### a. Optical section drive

The optical section is driven as follows: The drive power is transmitted from the scanner motor (MIM) through the belt to the drive pulley/wire, and the copy lamp unit and the mirror base which are attached to the wire are driven.

The scanner motor (MIM) is controlled with the signals sent from the scanner control PWB.

#### b. Scanner lamp drive

The scanner lamp is driven by the scanner lamp drive voltage which is generated by the scanner lamp drive PWB with the control signals sent from the scanner control PWB.

#### c. Image scan and color separation

Light is radiated onto the document by the scanner lamp and the reflected image is scanned by the 3-line (RGB) CCD elements to be converted into analog image signals.

The color components are extracted into R, G, and B by the three kinds of CCD elements (R, G, and B).

The red CCD extracts the red component of an image, the green CCD extracts the green component, and the blue CCD extracts the blue component. This operation is called color separation.

The CCD element is apparently seen as one unit, but it includes the three kinds of elements (R, G, and B).

The CCD element scans the document in the main scanning direction. Scanning in the sub scanning direction is made by shifting the scanner unit with the scanner motor.

The document images are optically reduced by the lens and reflected to the CCD.

The scanning direction is 600dpi.

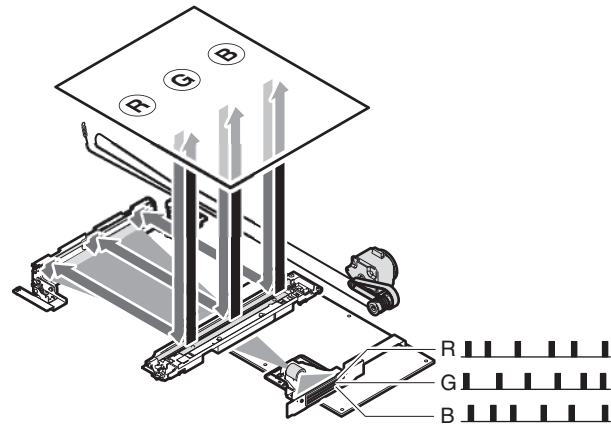
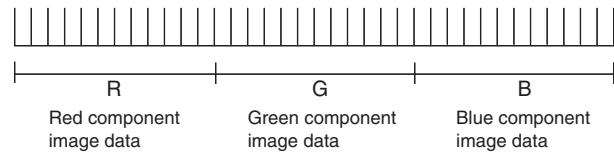
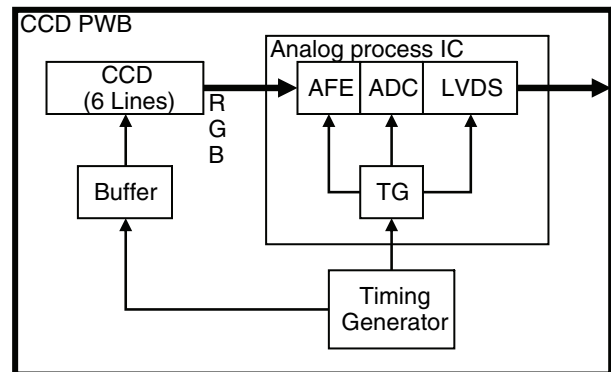

Image data of one line



#### d. Image signal A/D conversion

- 1) Each image signal (analog) of R, G, and B is converted into a 10bit digital signal by the A/D converter in the CCD PWB. Each color pixel has 10bit information.
- 2) Each 10bit digital image signal of R, G, and B is outputted from the CCD PWB and sent to the SCU PWB, where it is converted into an 8bit signal and sent to the MFP PWB.



#### e. Zooming operation

Zooming in the sub scanning direction is performed by changing the scanning speed in the sub scanning direction.

Zooming in the main scanning direction is not made optically, but performed by the image process technology (software).

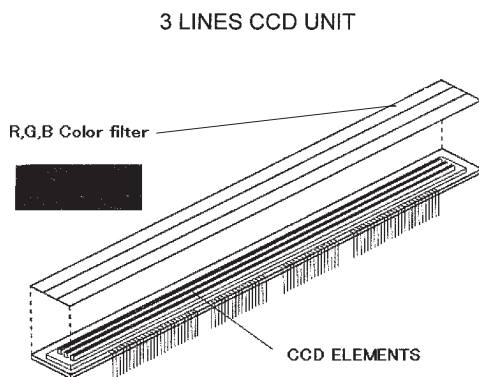

### 3. Manual paper feed section

#### A. Electrical and mechanical relation diagram

##### (1) 18cpm/20cpm/23cpm/26cpm/31cpm machine

##### a. 18cpm/20cpm machine

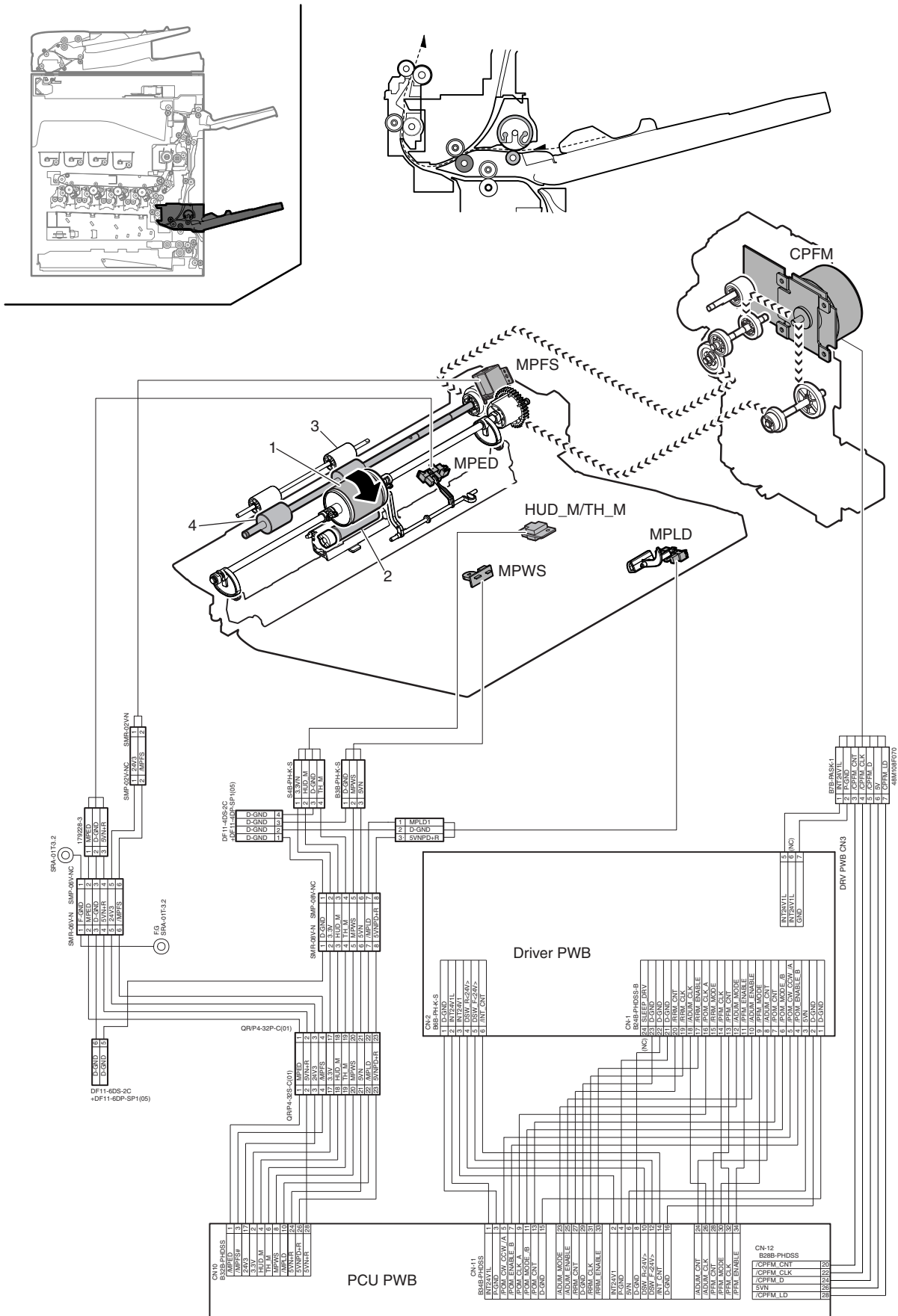



Signal name	Name	Function/Operation
CPFM	Paper feed motor	Drives the paper feed section.
HUD_M/TH_M	Temperature/humidity sensor	Detects the temperature and the humidity. (For the process control)
MPED	Paper empty sensor (Manual paper feed tray)	Detects presence of paper. (Manual paper feed tray)
MPFS	Paper feed solenoid (Manual paper feed)	Controls the paper feed roller. (Manual paper feed)
MPLD	Paper length detector (Manual paper feed tray )	Detects the paper length. (Manual paper feed tray)
MPWS	Paper width detector (Manual paper feed tray)	Detects the paper width. (Manual paper feed tray)
PFM	Transport motor	Drives the transport rollers 5 and 9.

No.	Name	Function/Operation
1	Paper feed roller (Manual paper feed tray)	Feeds paper to the paper transport section.
2	Separation roller (Manual paper feed tray)	Separates paper to prevent double-feeding.
3	Transport roller 9 (Idle)	Apply a pressure to paper and the transport roller to provide the transport power of the transport roller to paper.
4	Transport roller 9 (Drive)	Transports paper transported from the transport roller 5 to the transport roller 9.

(2) 36cpm machine

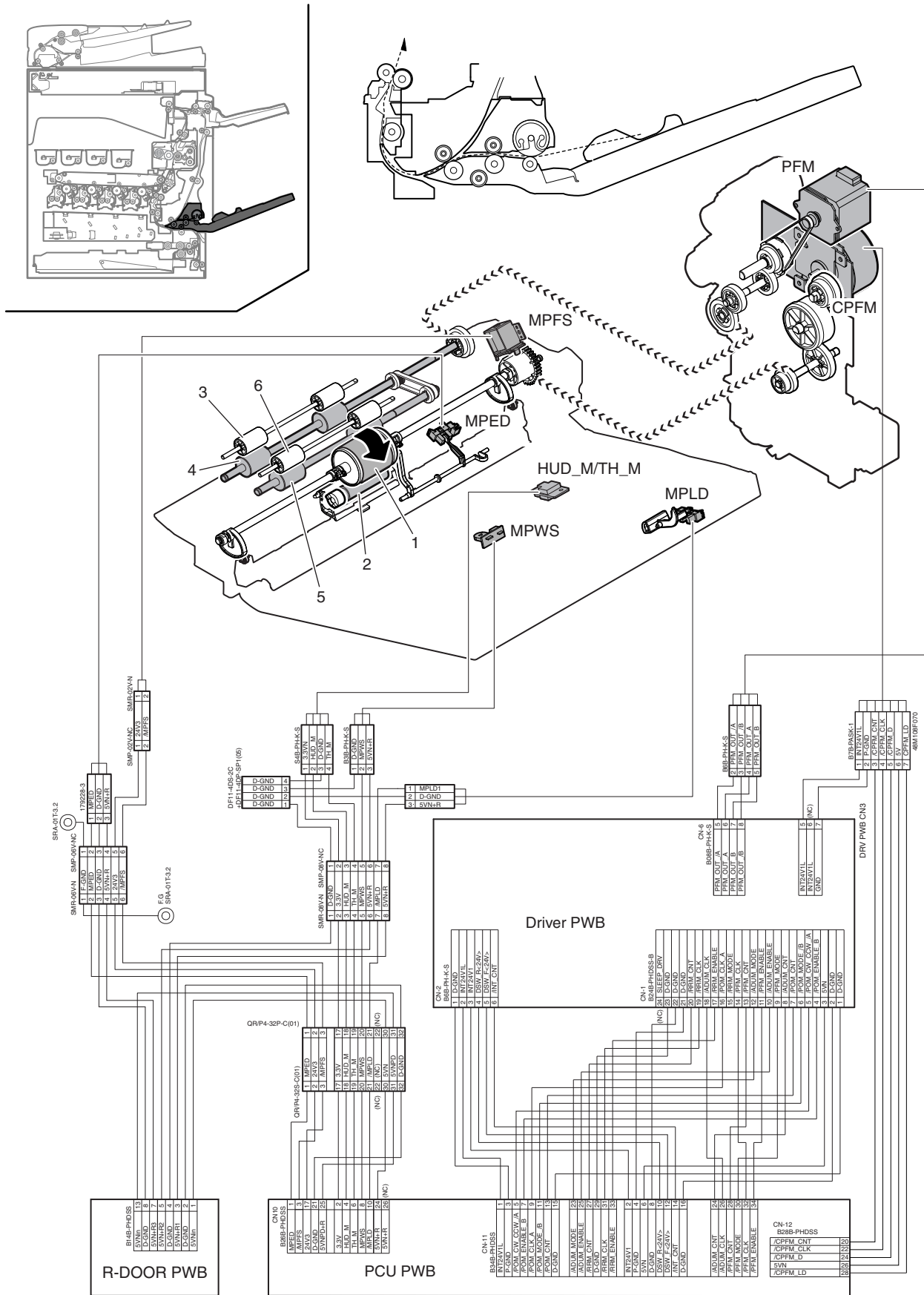

Signal name	Name	Function/Operation
CPFM	Paper feed motor	Drives the paper feed section.
HUD_M/TH_M	Temperature/humidity sensor	Detects the temperature and the humidity. (For the process control)
MPED	Paper empty sensor (Manual paper feed tray)	Detects presence of paper. (Manual paper feed tray)
MPFS	Paper feed solenoid (Manual paper feed)	Controls the paper feed roller. (Manual paper feed)
MPLD	Paper length detector (Manual paper feed tray)	Detects the paper length. (Manual paper feed tray)
MPWS	Paper width detector (Manual paper feed tray)	Detects the paper width. (Manual paper feed tray)
PFM	Transport motor	Drives the transport rollers 5 and 9.

No.	Name	Function/Operation
1	Paper feed roller (Manual paper feed tray)	Feeds paper to the paper transport section.
2	Separation roller (Manual paper feed tray)	Separates paper to prevent double-feeding.
3	Transport roller 9 (Idle)	Apply a pressure to paper and the transport roller to provide the transport power of the transport roller to paper.
4	Transport roller 9 (Drive)	Transports paper transported from the transport roller 5 to the transport roller 9.
5	Transport roller 10 (Drive)	Transports paper from manual paper feed section to the transport roller 9.
6	Transport roller 10 (Idle)	Apply a pressure to paper and the transport roller to provide the transport power of the transport roller to paper.

## B. Operational descriptions

### (1) Paper feed operation

The pickup roller moves up and down to press the paper surface, separating the paper on the top of the paper bundle and sending it to the paper feed roller section.

The paper feed roller feeds paper to the transport section to prevent against double feed with the separation roller. The manual paper feed clutch controls ON/OFF of the pickup roller and the paper feed roller. Paper is sent to the registration roller by the manual transport roller.

### (2) Paper size detection

The paper size is detected by the combination of the following detectors on the manual paper feed tray.

#### Paper size detection table

Series	Paper size	Paper length detector (MPLD)	Paper width detector (MPWS)
			Detection width (mm)
AB series	A3W	ON	301 - 310.4
	A3	ON	291 - 301
	11" x 17"	ON	273.4 - 285.4
	B4	ON	251 - 263
	8.5" x 14"	ON	209.9 - 221.9
	8.5" x 13"	ON	209.9 - 221.9
	A4	–	291 - 305
	8.5" x 11"	–	273.4 - 285.4
	B5	–	251 - 263
	A4R	–	204 - 216
	B5R	–	176 - 188
	A5R	–	142.5 - 154
Postcard	–	96 - 106	
INCH series	12" x 18"	ON	301 - 310.4
	A3	ON	291 - 301
	11" x 17"	ON	273.4 - 285.4
	B4	ON	251 - 263
	8.5" x 14"	ON	209.9 - 221.9
	8.5" x 13"	ON	209.9 - 221.9
	A4	–	291 - 305
	8.5" x 11"	–	273.4 - 285.4
	B5	–	251 - 263
	8.5" x 11"R	–	209.9 - 221.9
7.25" x 10.5"R	–	178.1 - 190.1	
5.5" x 8.5"R	–	133.7 - 145.7	

# 4. Tray paper feed section

## A. Electrical and mechanical relation diagram

(1) 18cpm/20cpm/23cpm/26cpm/31cpm machine

a. 18cpm/20cpm machine

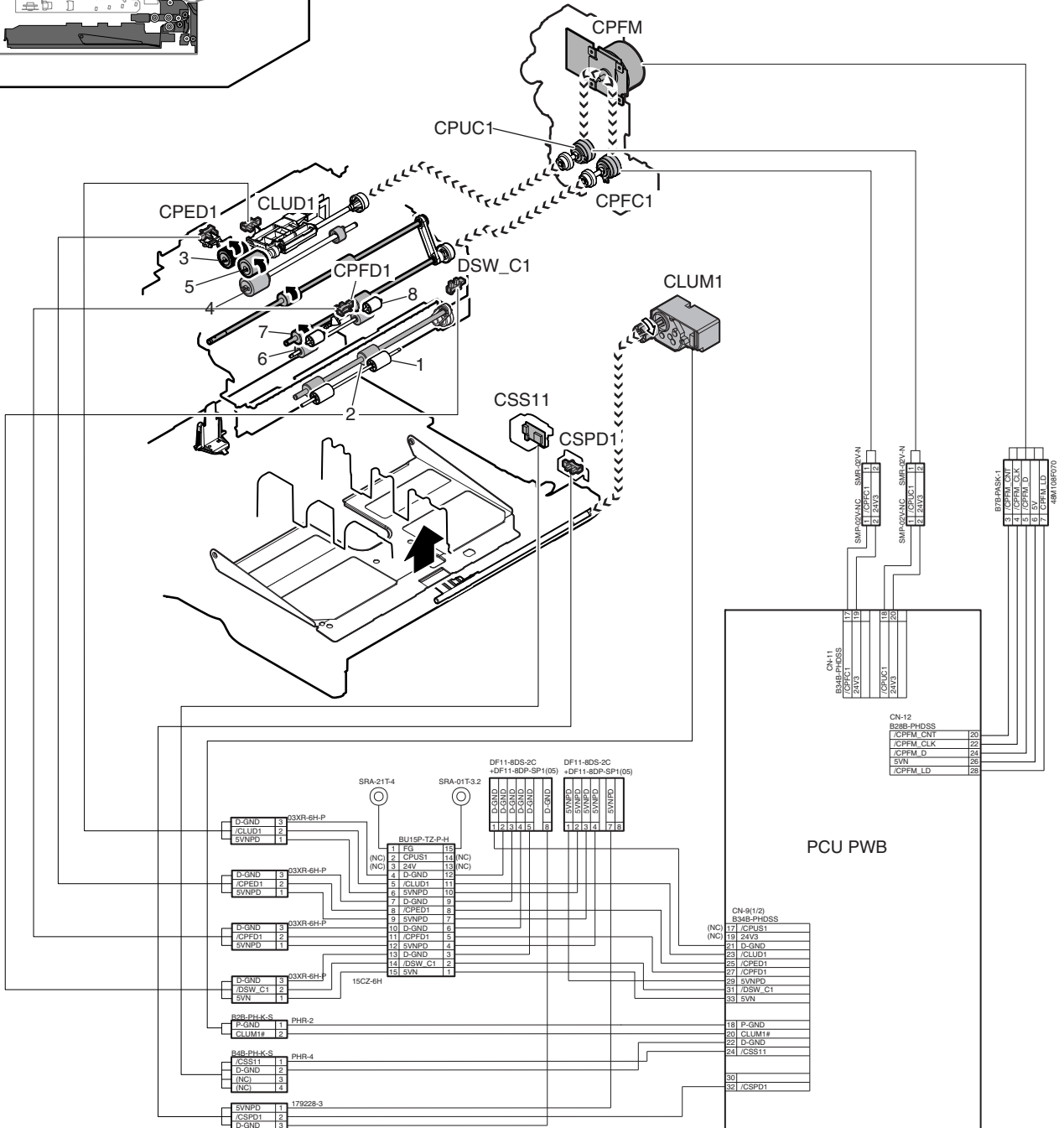
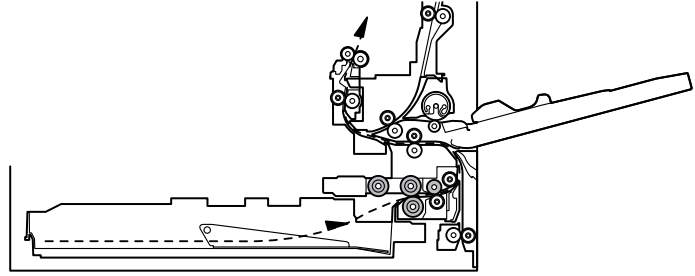
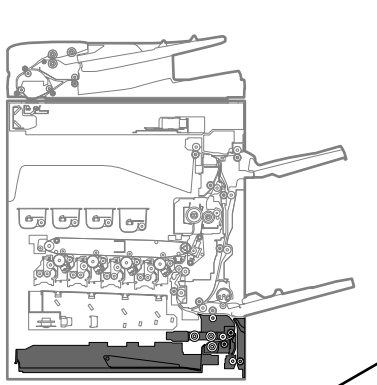



b. 23cpm/26cpm/31cpm machine

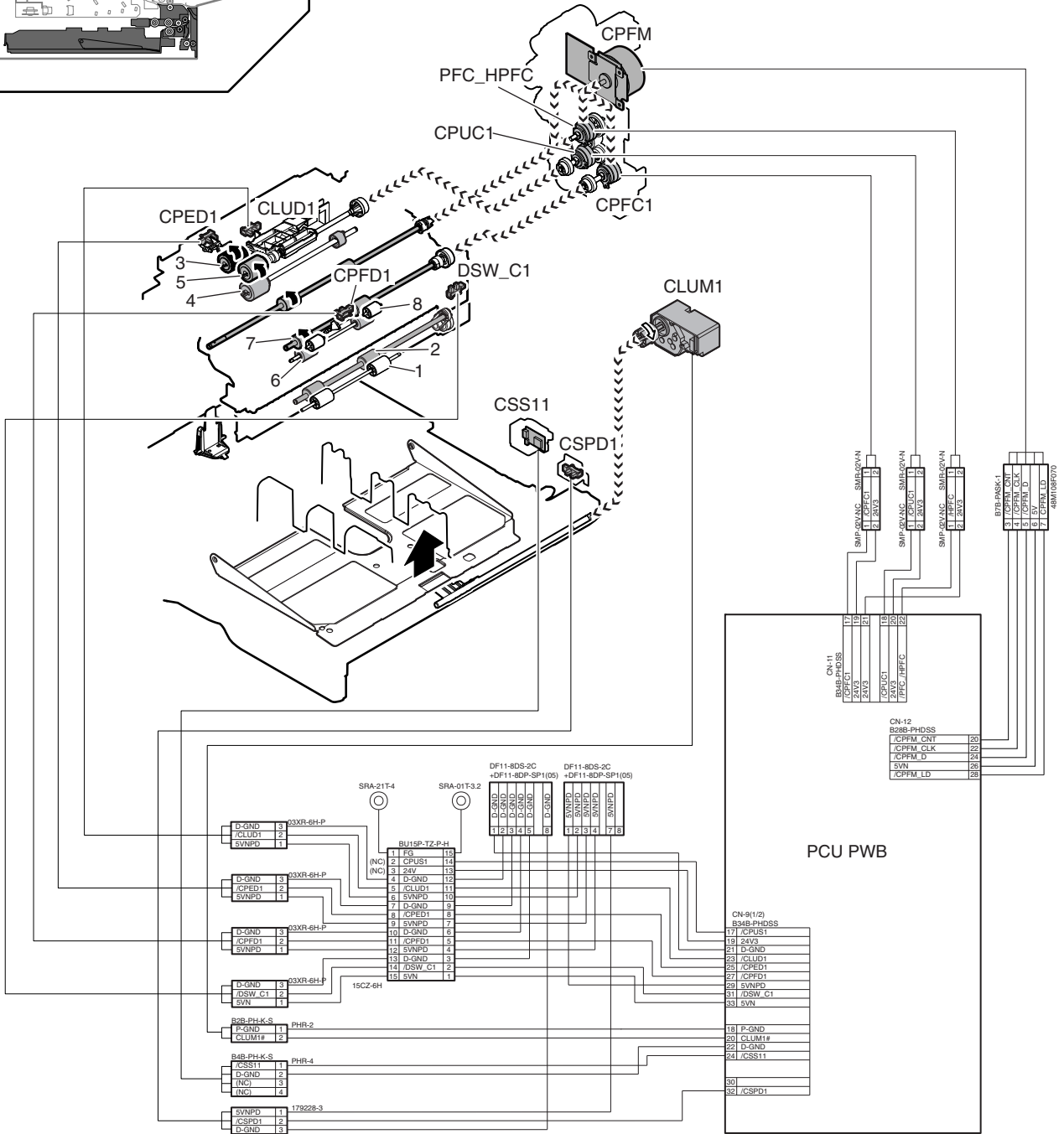
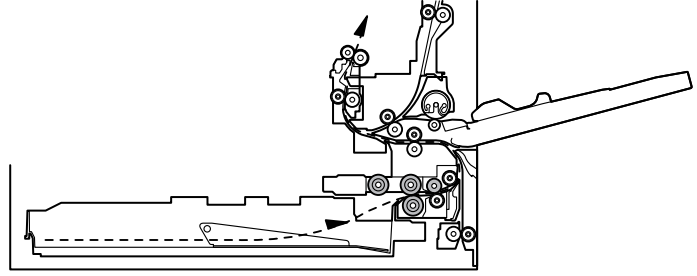
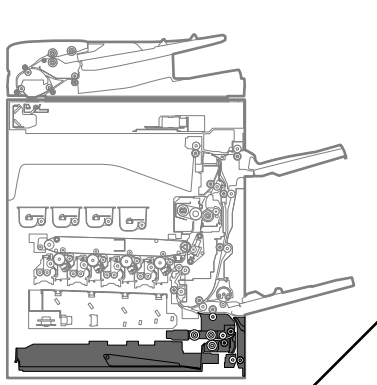

Signal name	Name	Function/Operation
CLUD1	Paper feed tray upper limit sensor (Paper feed tray 1)	Detects the upper limit of the paper lift up. (Paper feed tray 1)
CLUM1	Paper tray lift motor (Paper feed tray 1)	Lifts the lift plate of the paper feed tray. (Paper feed tray 1)
CPED1	Paper empty sensor (Paper feed tray 1)	Detects paper empty. (Paper feed tray 1)
CPFC1	Tray vertical transport clutch 1	Controls the transport roller of the paper feed tray 1 section.
CPFD1	Paper transport detector (Paper feed tray 1)	Detects paper pass in the paper transport section of the paper feed tray 1.
CPFM	Paper feed motor	Drives the paper feed section.
CPUC1	Paper feed clutch (Paper feed tray 1)	Controls ON/OFF of the paper feed roller in the paper feed tray 1 section. (Paper feed tray 1)
CSPD1	Paper remaining quantity sensor (Paper feed tray 1)	Detects the paper remaining quantity. (Paper feed tray 1)
CSS11	Paper feed tray size detector (Paper feed tray 1)	Detects the paper size. Detects closing of the paper feed tray. (Paper feed tray 1)
DSW_C1	Transport cover open/close detector (Paper feed tray 1)	Detects open/close of the transport section cover. (Paper feed tray 1)
PFC_HPFC	Transport roller clutch	Controls the transport roller 4.

No.	Name	Function/Operation
1	Transport roller 1 (Idle)	Apply a pressure to paper and the transport roller to provide the transport power of the transport roller to paper.
2	Transport roller 1 (Drive)	Transports paper fed from the paper feed desk tray to the transport roller 4.
3	Paper pickup roller (No. 1 paper feed tray)	Feeds paper to the paper feed roller.
4	Separation roller (No. 1 paper feed tray)	Separates paper to prevent double-feeding.
5	Paper feed roller (No. 1 paper feed tray )	Feeds paper to the paper transport section.
6	Transport roller 2 (Idle)	Apply a pressure to paper and the transport roller to provide the transport power of the transport roller to paper.
7	Transport roller 2 (Drive)	Transports paper fed from the paper feed tray 1 to the transport roller 3.
8	Transport roller 3	Transports paper from the transport roller 2 to the transport roller 4.

(2) 36cpm machine

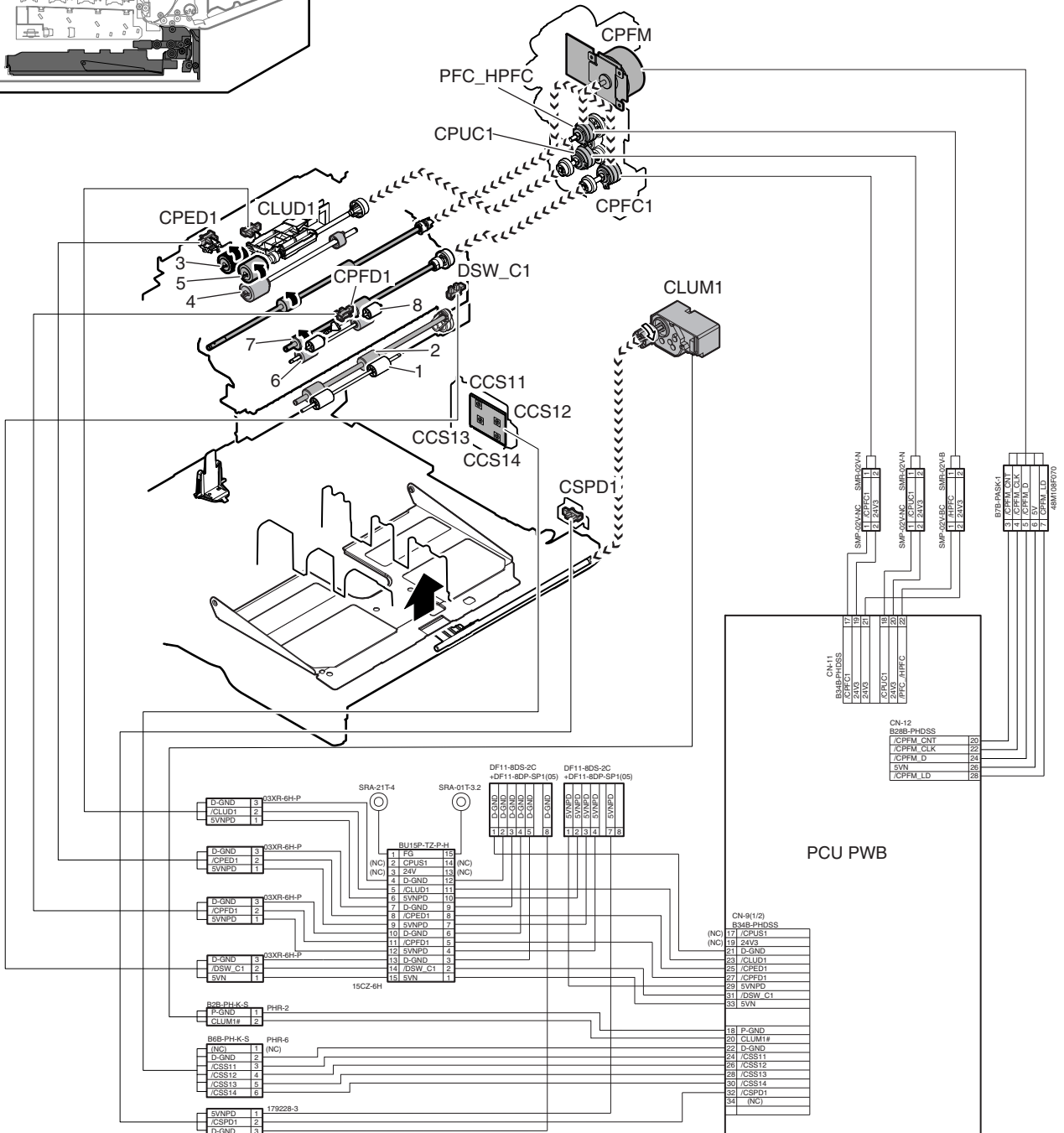
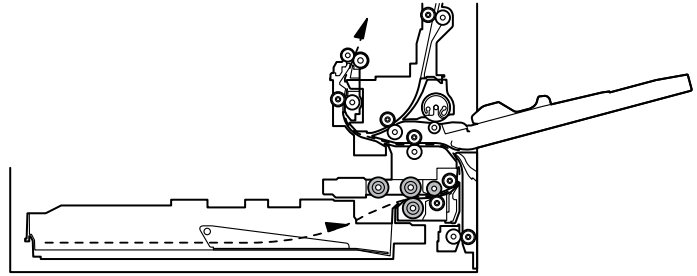
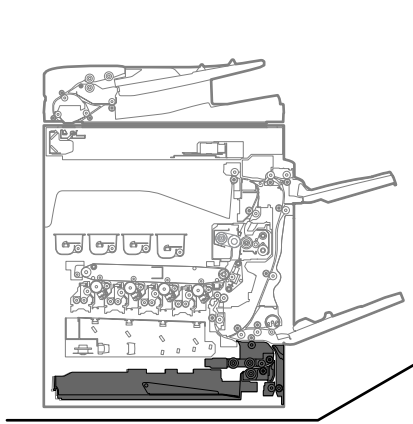

Signal name	Name	Function/Operation
CLUD1	Paper feed tray upper limit sensor (Paper feed tray 1)	Detects the upper limit of the paper lift up. (Paper feed tray 1)
CLUM1	Paper tray lift motor (Paper feed tray 1)	Lifts the lift plate of the paper feed tray. (Paper feed tray 1)
CPED1	Paper empty sensor (Paper feed tray 1)	Detects paper empty. (Paper feed tray 1)
CPFC1	Tray vertical transport clutch 1	Controls the transport roller of the paper feed tray 1 section.
CPFD1	Paper transport detector (Paper feed tray 1)	Detects paper pass in the paper transport section of the paper feed tray 1.
CPFM	Paper feed motor	Drives the paper feed section.
CPUC1	Paper feed clutch (Paper feed tray 1)	Controls ON/OFF of the paper feed roller in the paper feed tray 1 section. (Paper feed tray 1)
CSPD1	Paper remaining quantity sensor (Paper feed tray 1)	Detects the paper remaining quantity. (Paper feed tray 1)
CSS11	Paper feed tray size detector (Paper feed tray 1)	Detects the paper size.
CSS12		Detects closing of the paper feed tray. (Paper feed tray 1)
CSS13		
CSS14		
DSW_C1	Transport cover open/close detector (Paper feed tray 1)	Detects open/close of the transport section cover. (Paper feed tray 1)
PFC_HPFC	Transport roller clutch	Controls the transport roller 4.

No.	Name	Function/Operation
1	Transport roller 1 (Idle)	Apply a pressure to paper and the transport roller to provide the transport power of the transport roller to paper.
2	Transport roller 1 (Drive)	Transports paper fed from the paper feed desk tray to the transport roller 4.
3	Paper pickup roller (No. 1 paper feed tray)	Feeds paper to the paper feed roller.
4	Separation roller (No. 1 paper feed tray)	Separates paper to prevent double-feeding.
5	Paper feed roller (No. 1 paper feed tray )	Feeds paper to the paper transport section.
6	Transport roller 2 (Idle)	Apply a pressure to paper and the transport roller to provide the transport power of the transport roller to paper.
7	Transport roller 2 (Drive)	Transports paper fed from the paper feed tray 1 to the transport roller 3.
8	Transport roller 3	Transports paper from the transport roller 2 to the transport roller 4.

## B. Operational descriptions

### (1) Paper feed front operation

- Set paper and insert the paper feed tray, and the pickup roller falls to turn ON the paper feed tray sensor.
- The lift-up motor drives the rotating plate to move it up.
- The paper upper limit sensor turns ON, and the rotation plate stops at the specified position.

### (2) Paper feed operation

- When copy/print operation is started, the motor and the clutch are turned ON to rotate the pickup roller in the paper pickup timing, feeding paper.
- At the same time, the paper feed roller rotates to transport paper to the transport section. At that time, the separation roller rotates to prevent against double feed of paper.

### (3) Paper remaining detection

The notifying levels of paper remaining quantity are 4 steps in total; 3 steps of paper remaining quantity and 1 step of paper empty. The result is displayed.

**(4) Paper remaining quantity detection method**

- The paper remaining quantity is judged from the number of rotations of the remaining quantity sensor from starting the lift-up operation of the paper feed tray to turning ON the upper limit sensor.

**(Figure showing state transition of the remaining paper detection sensor during tray elevation and changes in status according to the number of remaining sheets)**

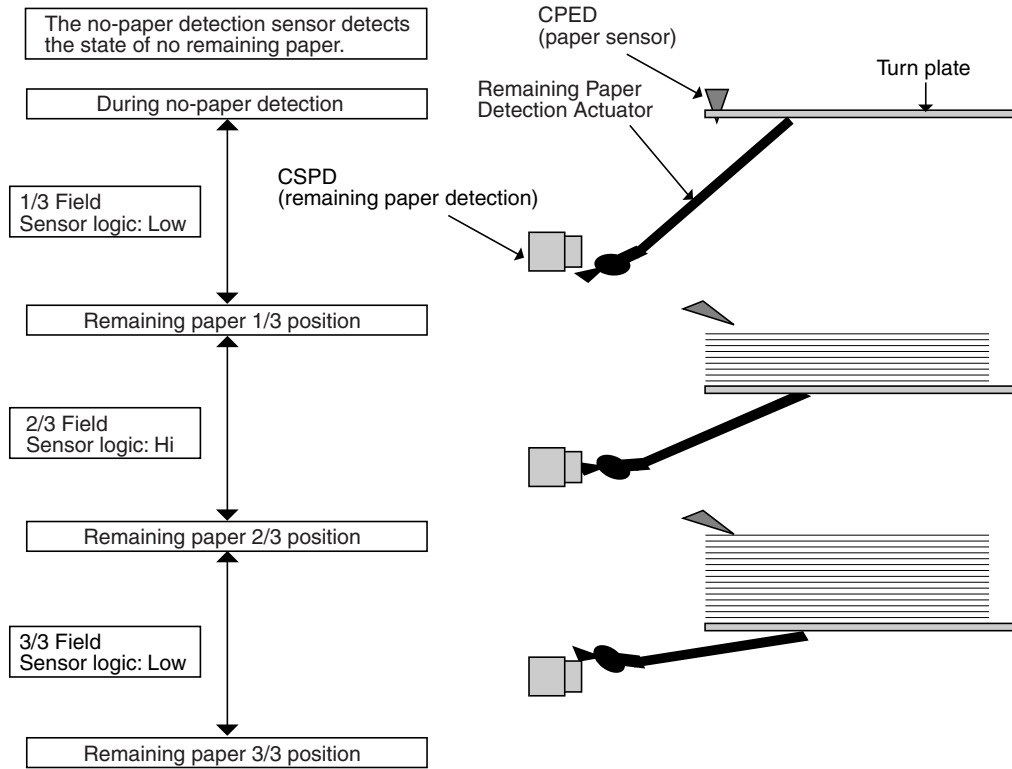



b. 23cpm/26cpm/31cpm machine

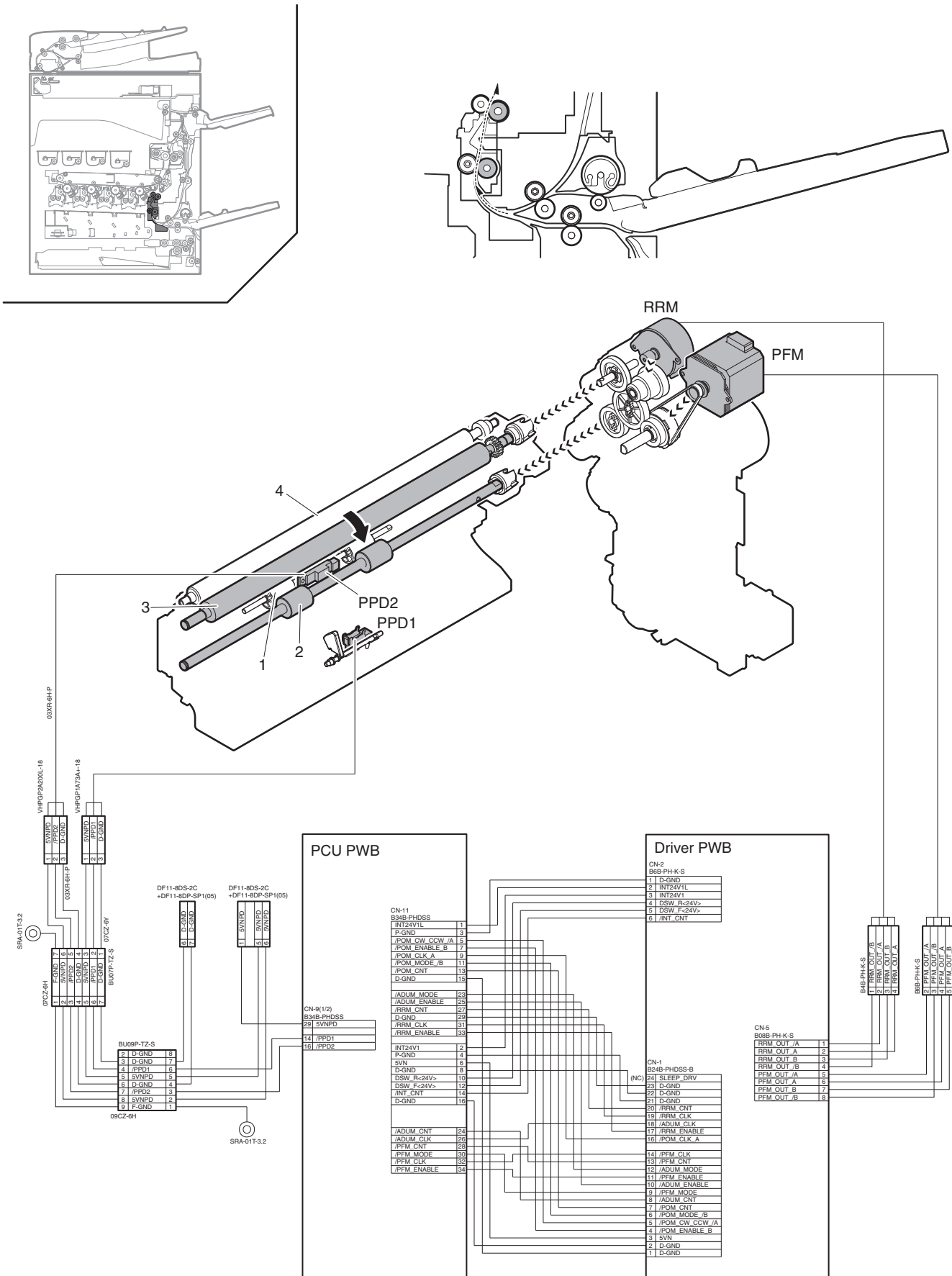

Signal name	Name	Function/Operation
PFM	Transport motor	Drives the transport rollers 5 and 9.
PPD1	Paper transport detector 1	Detects paper pass in front of the transport roller 5.
PPD2	Paper transport detector 2	Detects paper pass in the transport roller 5 in front of the registration roller.
PFC_HPFC	Transport roller clutch	Controls the transport roller 5. (18cpm/20cpm machine)
RRC	Registration roller clutch	Controls the registration roller. (Controls the timing of the transfer image for the paper.) (18cpm/20cpm machine)
RRM	Registration motor	Drives the registration roller. (Controls the timing of the transfer image for the paper.) (23/26/31cpm machine)

No.	Name	Function/Operation
1	Transport roller 5 (Idle)	Apply a pressure to paper and the transport roller to provide the transport power of the transport roller to paper.
2	Transport roller 5 (Drive)	Transports paper to the registration roller. / Paper is warped between the registration roller and this roller to correct the paper skew and the relation between images and paper.
3	Registration roller (Drive)	Transports paper to the transfer section. / Controls the transport timing of paper and adjusts relative relations between the image and paper.
4	Registration roller (Idle)	Apply a pressure to paper and the registration roller to provide the transport power of the transport roller to paper.



## (2) 36cpm machine

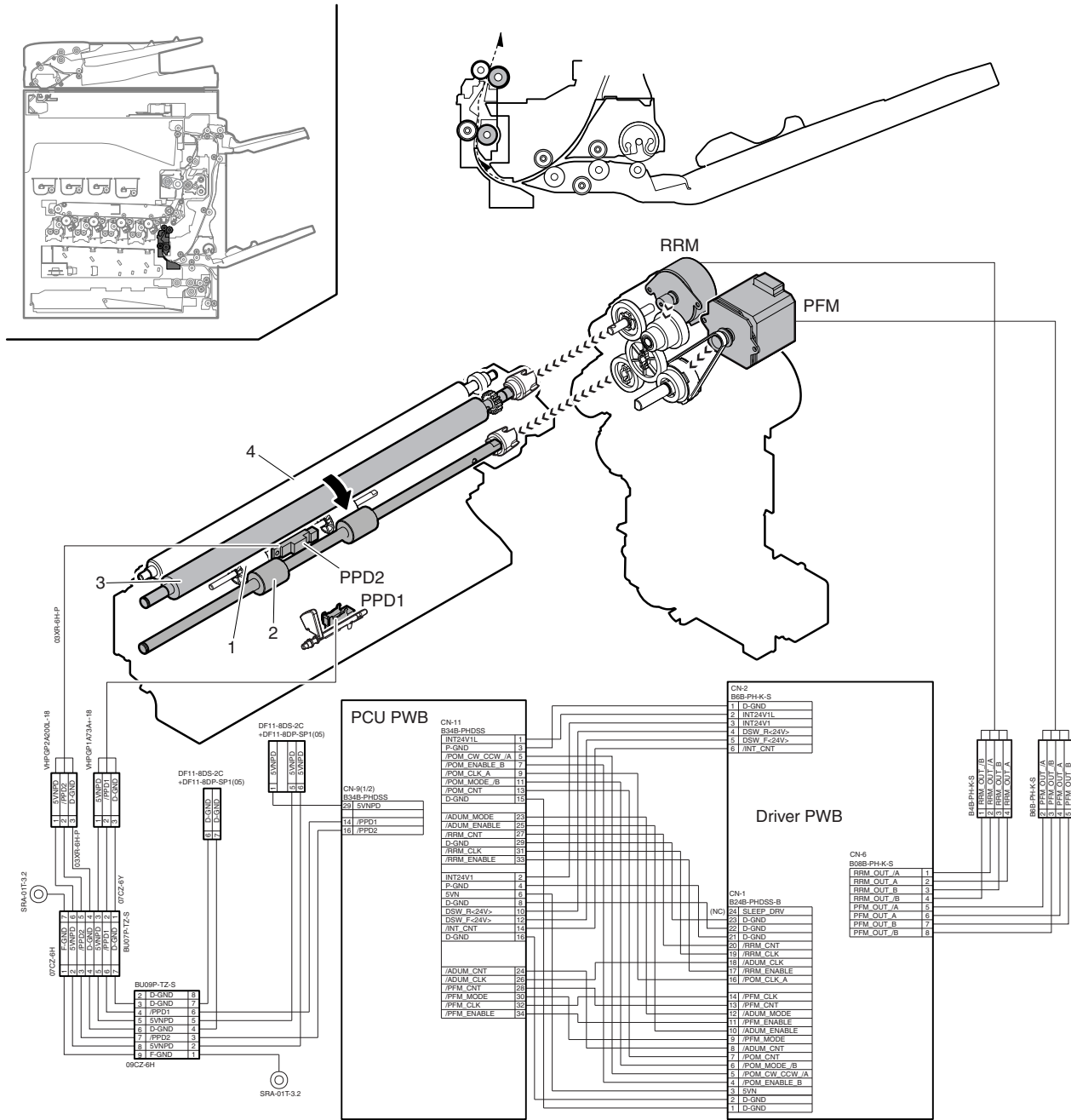

Signal name	Name	Function/Operation
PFM	Transport motor	Drives the transport rollers 5 and 9.
PPD1	Paper transport detector 1	Detects paper pass in front of the transport roller 5.
PPD2	Paper transport detector 2	Detects paper pass in the transport roller 5 in front of the registration roller.
RRM	Registration motor	Drives the registration roller. (Controls the timing of the transfer image for the paper.)

No.	Name	Function/Operation
1	Transport roller 5 (Idle)	Apply a pressure to paper and the transport roller to provide the transport power of the transport roller to paper.
2	Transport roller 5 (Drive)	Transports paper to the registration roller. / Paper is warped between the registration roller and this roller to correct the paper skew and the relation between images and paper.
3	Registration roller (Drive)	Transports paper to the transfer section. / Controls the transport timing of paper and adjusts relative relations between the image and paper.
4	Registration roller (Idle)	Apply a pressure to paper and the registration roller to provide the transport power of the transport roller to paper.

## B. Operational descriptions

Paper is fed from each paper feed section and transported to the registration roller by the transport rollers. ON/OFF control of each transport roller is made by the paper transport clutch. The registration roller controls the relative positions of transported paper and the transfer image. The registration roller is driven by the transport motor. The relative positions of paper and the transfer image are determined by the ON timing of the transport motor.

# 6. Paper exit section

## A. Electrical and mechanical relation diagram

### (1) 18cpm/20cpm/23cpm/26cpm/31cpm machine

#### a. 18cpm machine

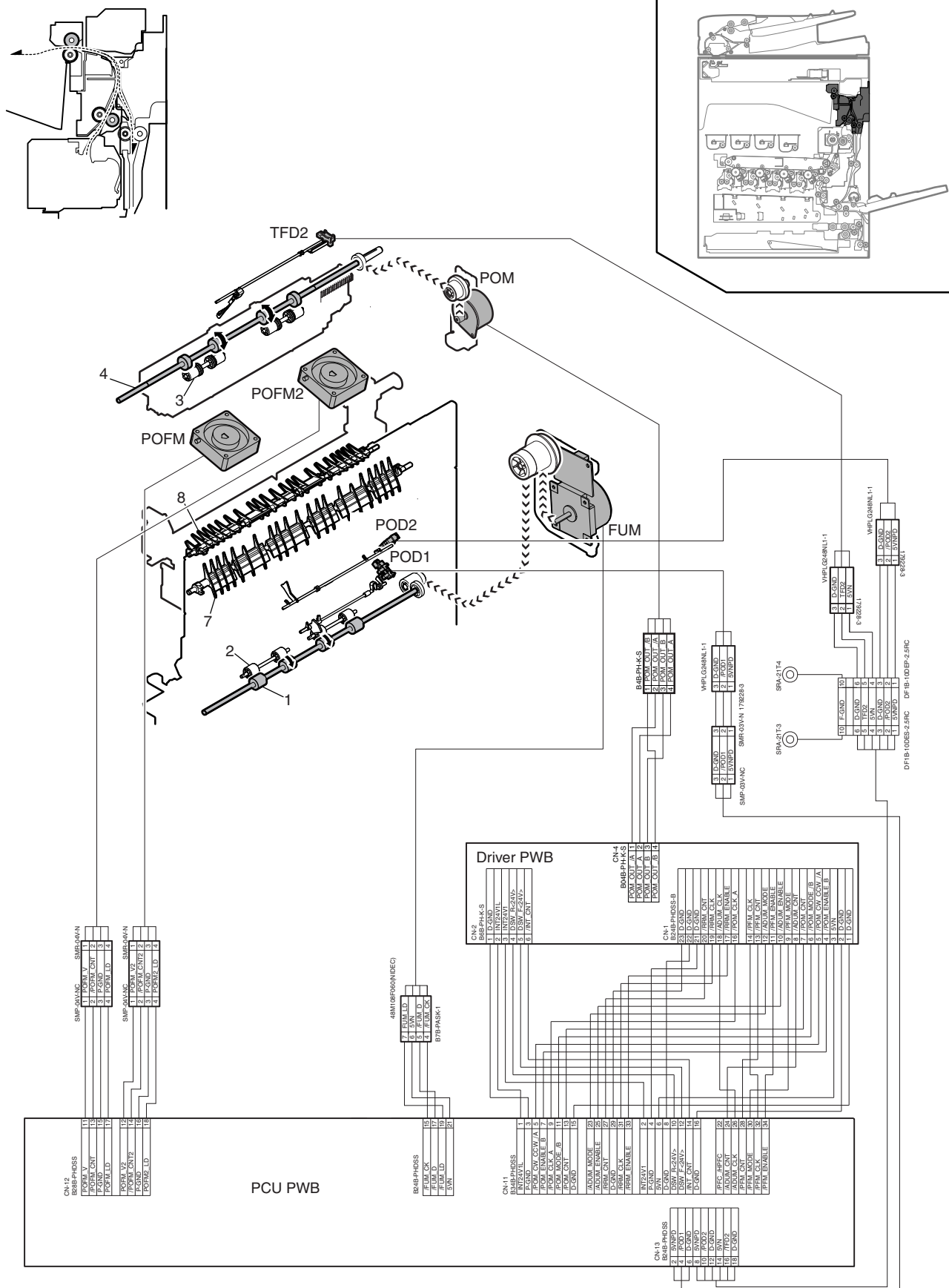

b. 20cpm machine

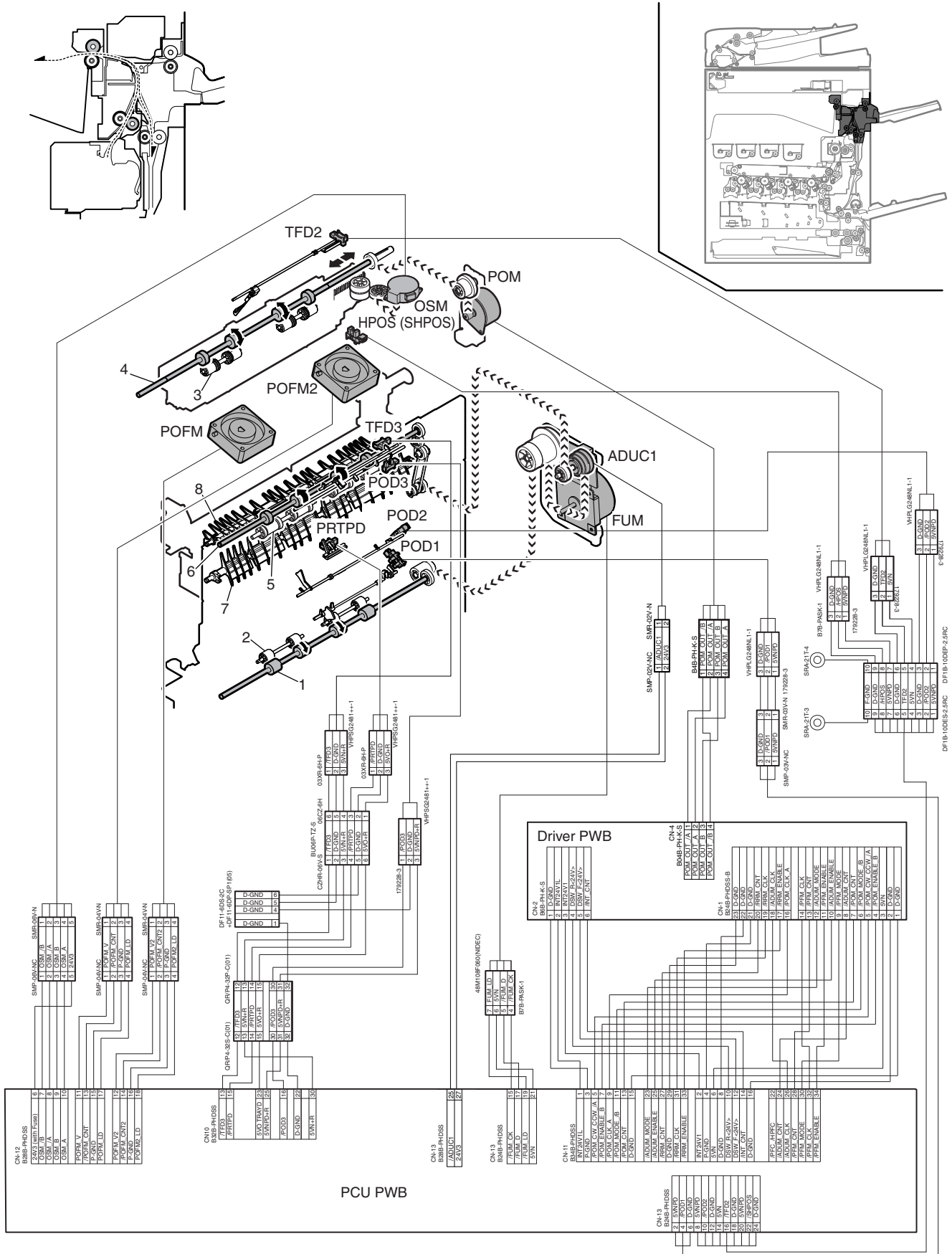

c. 23cpm/26cpm/31cpm machine

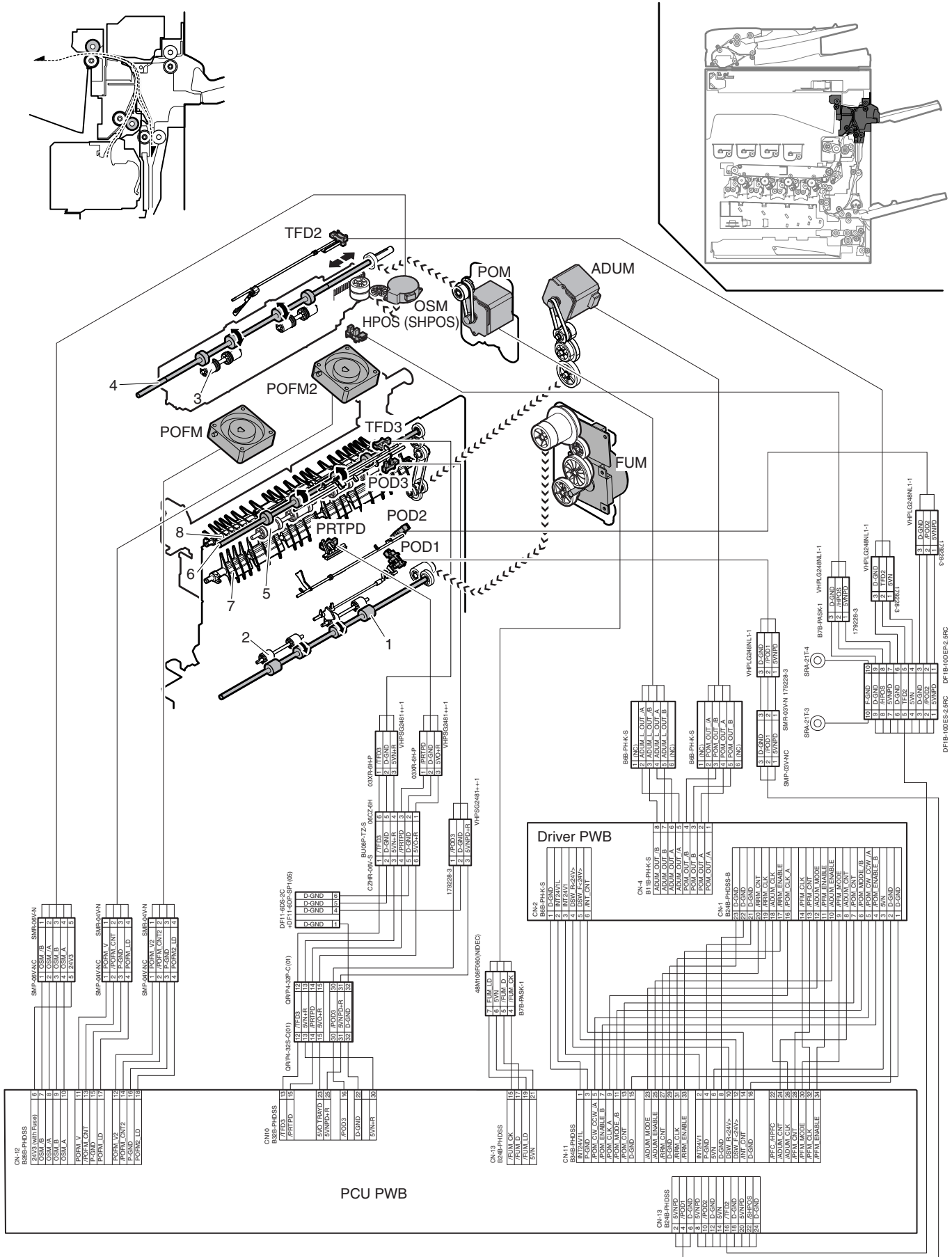

Signal name	Name	Function/Operation
ADUC1	ADU clutch	Drives the ADU and the transport roller in the right paper exit section. (18cpm/20cpm machine)
ADUM	ADU motor	Drives the ADU and the transport roller in the right paper exit section. (23cpm machine)
FUM	Fusing motor	Drives the fusing section. (23cpm machine)/Drives the ADU and the transport roller in the right paper exit section. (18cpm/20cpm machine)
HPOS (SHPOS)*	Shifter home positions sensor	Detects the shifter home position.
OSM	Offset motor	Offsets (shifts) paper.
POD1	Paper exit detector 1	Detects paper transport from the fusing section.
POD2	Paper exit detector 2	Detects paper transport to the face-down paper exit tray.
POD3*	Paper exit detector 3	Detects paper transport to the right paper exit tray.
POFM	Paper exit cooling fan	Cools the fusing section and the paper exit section.
POFM2	Paper exit cooling fan	Cools the fusing section and the paper exit section.
POM	Paper exit motor	Drives the roller in the paper exit section.
PRTPD*	Paper exit tray paper detector (Right paper exit tray)	Detects paper empty in the paper exit tray (Right paper exit tray).
TFD2	Paper exit tray full detector (Face-down tray)	Detects paper full in the face-down paper exit tray.
TFD3*	Paper exit tray full detector (Right paper exit tray)	Detects paper full in the right paper exit tray.

No.	Name	Function/Operation
1	Transport roller 6 (Drive)	Transports paper transported from the fusing section to the paper exit section and the switchback section.
2	Transport roller 6 (Idle)	Apply a pressure to paper and the transport roller to provide the transport power of the transport roller to paper.
3	Paper exit roller 1 (Idle)	Apply a pressure to paper and the paper exit roller to provide the transport power of the paper exit roller to paper.
4	Paper exit roller 1 (Drive)	Transports paper to the left paper exit section.
5	Paper exit roller 2 (Idle)	Apply a pressure to paper and the paper exit roller to provide the transport power of the paper exit roller to paper.
6	Paper exit roller 2 (Drive)	Discharges paper to the right paper exit tray.
7	Paper exit gate	Selects the paper path: to transport paper to the back surface print transport section or to the right tray.
8	Switchback gate	Switchbacks paper to transport it to the back surface print section.

\* 18cpm machine are not installed.

(2) 36cpm machine

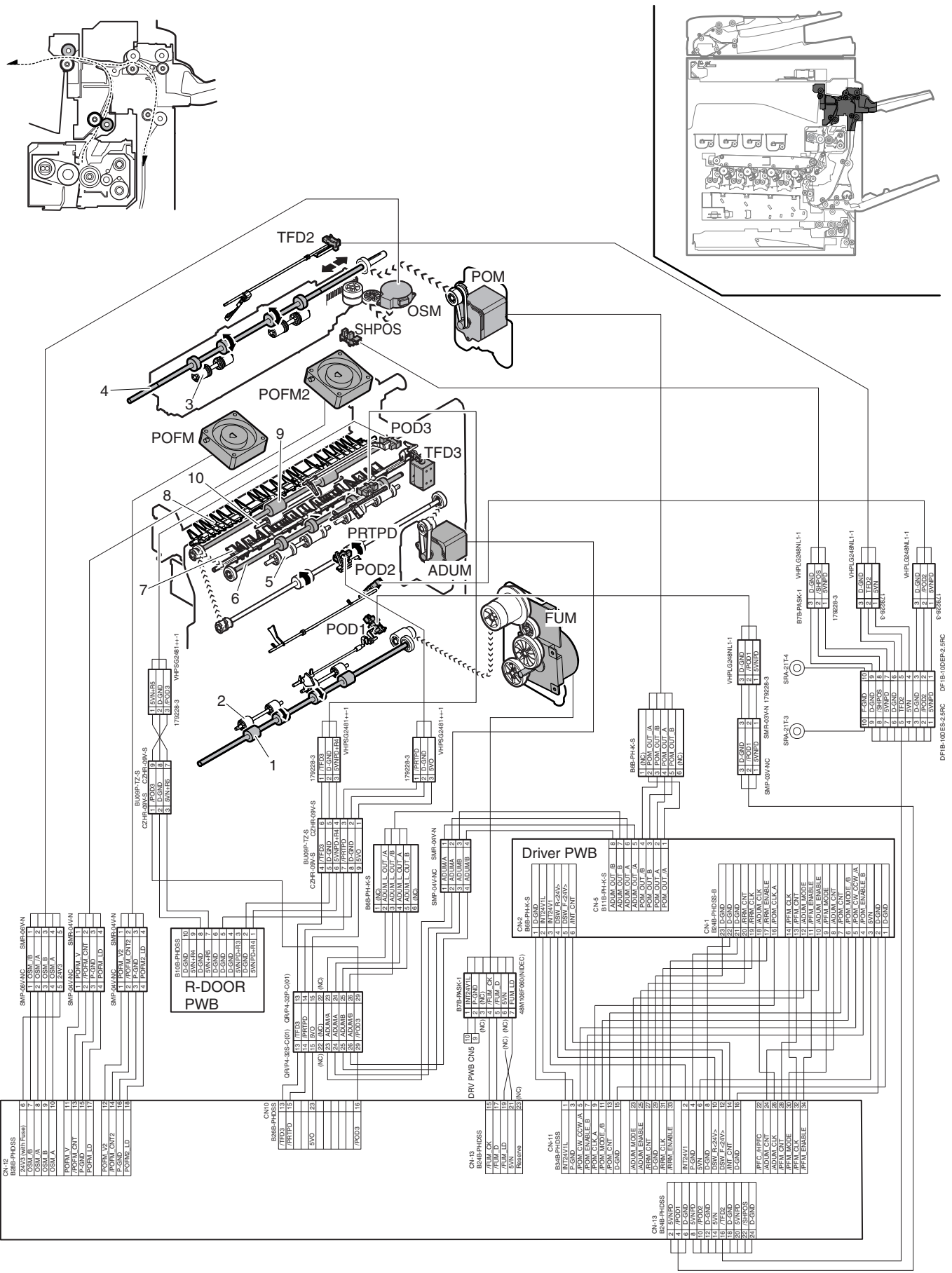

Signal name	Name	Function/Operation
ADUM	ADU motor	Drives the ADU and the transport roller in the right paper exit section.
FUM	Fusing motor	Drives the fusing section.
OSM	Offset motor	Offsets (shifts) paper.
POD1	Paper exit detector 1	Detects paper transport from the fusing section.
POD2	Paper exit detector 2	Detects paper transport to the face-down paper exit tray.
POD3	Paper exit detector 3	Detects paper transport to the right paper exit tray.
POFM	Paper exit cooling fan	Cools the fusing section and the paper exit section.
POFM2	Paper exit cooling fan	Cools the fusing section and the paper exit section.
POM	Paper exit motor	Drives the roller in the paper exit section.
PRTPD	Paper exit tray paper detector (Right paper exit tray)	Detects paper empty in the paper exit tray (Right paper exit tray).
SHPOS	Shifter home positions sensor	Detects the shifter home position.
TFD2	Paper exit tray full detector (Face-down tray)	Detects paper full in the face-down paper exit tray.
TFD3	Paper exit tray full detector (Right paper exit tray)	Detects paper full in the right paper exit tray.

No.	Name	Function/Operation
1	Transport roller 6 (Drive)	Transports paper transported from the fusing section to the paper exit section and the switchback section.
2	Transport roller 6 (Idle)	Apply a pressure to paper and the transport roller to provide the transport power of the transport roller to paper.
3	Paper exit roller 1 (Idle)	Apply a pressure to paper and the paper exit roller to provide the transport power of the paper exit roller to paper.
4	Paper exit roller 1 (Drive)	Transports paper to the left paper exit section.
5	Paper exit roller 2 (Idle)	Apply a pressure to paper and the paper exit roller to provide the transport power of the paper exit roller to paper.
6	Paper exit roller 2 (Drive)	Discharges paper to the right paper exit tray.
7	Paper exit gate	Selects the paper path: to transport paper to the back surface print transport section or to the right tray.
8	Switchback gate	Switchbacks paper to transport it to the back surface print section.
9	Paper exit roller 3 (Drive)	Discharges paper to the right paper exit tray.
10	Paper exit roller 3 (Idle)	Apply a pressure to paper and the paper exit roller to provide the transport power of the paper exit roller to paper.

## B. Operational descriptions

- The paper transported from the fusing section is sent from transport roller 6 (which is driven by the ADU motor) to paper exit roller 1, and then discharged to the inner tray.
- When the paper is discharged to the right tray: The paper is transported to paper exit roller 1, and the paper exit motor is reversed. Then the paper is passed over the right paper exit gate through paper exit roller 2 to the right tray.

# 7. ADU section

## A. Electrical and mechanical relation diagram

### (1) 18cpm/20cpm/23cpm/26cpm/31cpm machine

#### a. 18cpm/20cpm machine

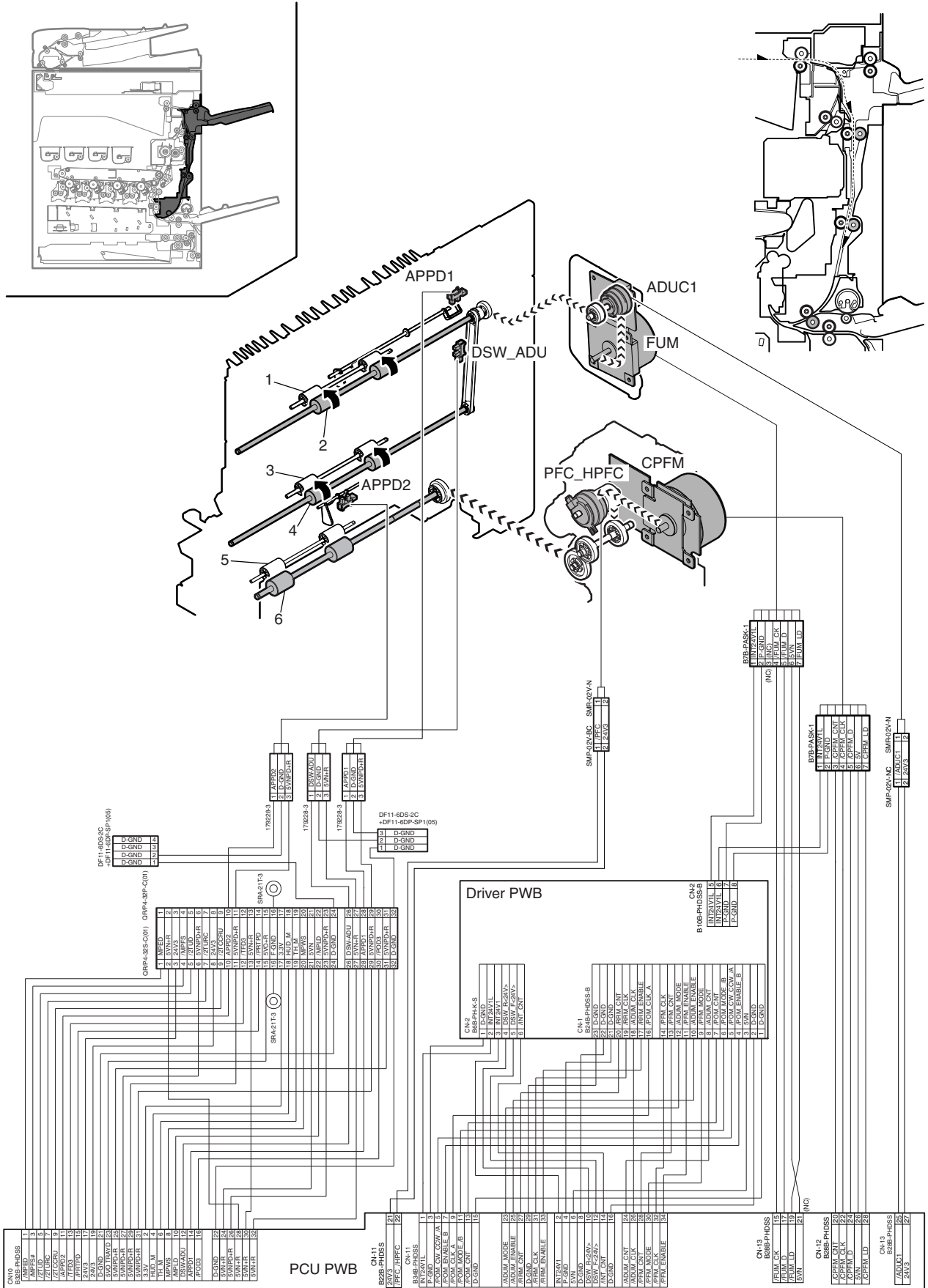



b. 23cpm/26cpm/31cpm machine

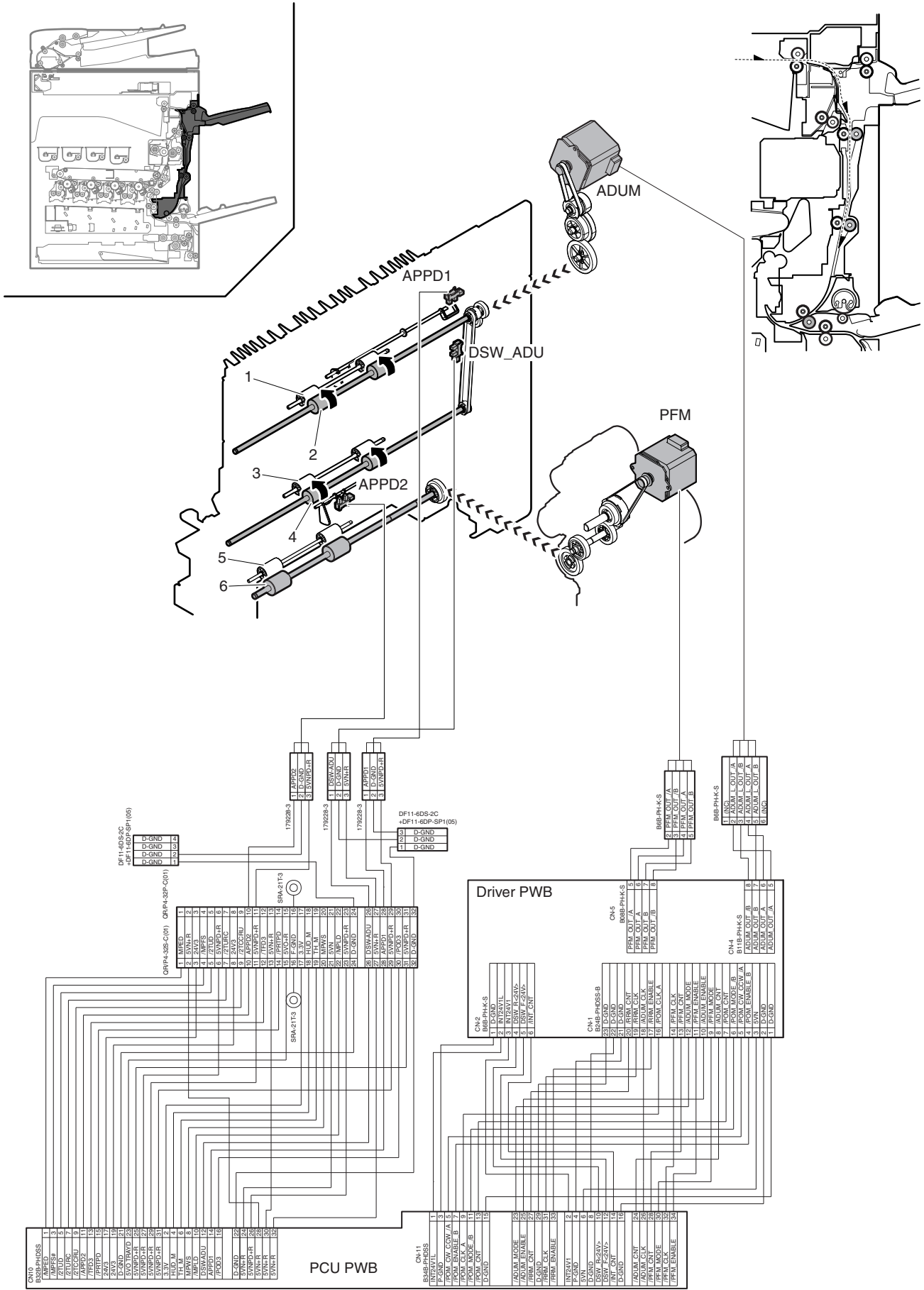

Signal name	Name	Function/Operation
ADUC1	ADU clutch	Controls the ADU and the transport roller in the right paper exit section. (18cpm/20cpm machine)
ADUM	ADU motor	Drives the transport roller in the ADU right paper exit section. (23/26/31cpm machine)
APPD1	ADU paper transport detector 1	Detects paper entry and paper pass in the ADU.
APPD2	ADU paper transport detector 2	Detects paper pass in the ADU transport roller 8.
CPFM	Paper feed motor	Drives the transport rollers 5 and 9. (18cpm/20cpm machine)
DSW_ADU	ADU paper guide open/close detector	Detects open/close of the ADU paper guide.
FUM	Fusing motor	Drives the transport roller in the ADU right paper exit section. (18cpm/20cpm machine)
PFC_HPFC	Transport roller clutch	Controls the transport roller 9. (18cpm/20cpm machine)
PFM	Transport motor	Drives the transport rollers 5 and 9. (23/26/31cpm machine)

No.	Name	Function/Operation
1	Transport roller 7 (Idle)	Apply a pressure to paper and the transport roller to provide the transport power of the transport roller to paper.
2	Transport roller 7 (Drive)	Transports paper transported from the switchback section to the transport roller 8.
3	Transport roller 8 (Idle)	Apply a pressure to paper and the transport roller to provide the transport power of the transport roller to paper.
4	Transport roller 8 (Drive)	Transports paper transported from the transport roller 7 to the transport roller 9.
5	Transport roller 9 (Idle)	Apply a pressure to paper and the transport roller to provide the transport power of the transport roller to paper.
6	Transport roller 9 (Drive)	Transports paper transported from the transport roller 8 to the transport roller 5.



Signal name	Name	Function/Operation
ADUM	ADU motor	Drives the transport roller in the ADU right paper exit section.
APPD1	ADU paper transport detector 1	Detects paper entry and paper pass in the ADU.
APPD2	ADU paper transport detector 2	Detects paper pass in the ADU transport roller 8.
DSW_ADU	ADU paper guide open/close detector	Detects open/close of the ADU paper guide.
PFM	Transport motor	Drives the transport rollers 5 and 9.
POD3	Paper exit detector 3	Detects paper transport to the right paper exit tray.

No.	Name	Function/Operation
1	Transport roller 7 (Idle)	Apply a pressure to paper and the transport roller to provide the transport power of the transport roller to paper.
2	Transport roller 7 (Drive)	Transports paper transported from the switchback section to the transport roller 8.
3	Transport roller 8 (Idle)	Apply a pressure to paper and the transport roller to provide the transport power of the transport roller to paper.
4	Transport roller 8 (Drive)	Transports paper transported from the transport roller 7 to the transport roller 9.
5	Transport roller 9 (Idle)	Apply a pressure to paper and the transport roller to provide the transport power of the transport roller to paper.
6	Transport roller 9 (Drive)	Transports paper transported from the transport roller 8 to the transport roller 5.
7	Paper exit roller 3 (Drive)	Discharges paper to the right paper exit tray.
8	Paper exit roller 3 (Idle)	Apply a pressure to paper and the paper exit roller to provide the transport power of the paper exit roller to paper.

### C. Operational descriptions

- The paper transported from the fusing section is sent from transport roller 6 (which is driven by the ADU motor) to paper exit roller 1. At that time, the paper passed under the gate.
- When POD1 detects the paper lead edge, the paper exit drive motor reverses.
- By reversion of the paper exit motor, the paper is sent to the ADU section. At that time, the paper passes over the ADU guide which fell by its own weight.
- Transport rollers 7 and 8 are driven the ADU motor, and transport roller 9 by the transport motor. The paper is transported to the duplex paper feed position.
- The paper is once stopped at the duplex paper feed position, and transported again to the inside of the machine.

# 8. LSU section

## A. Electrical and mechanical relation diagram

(1) 18cpm/20cpm/23cpm/31cpm(G) machine

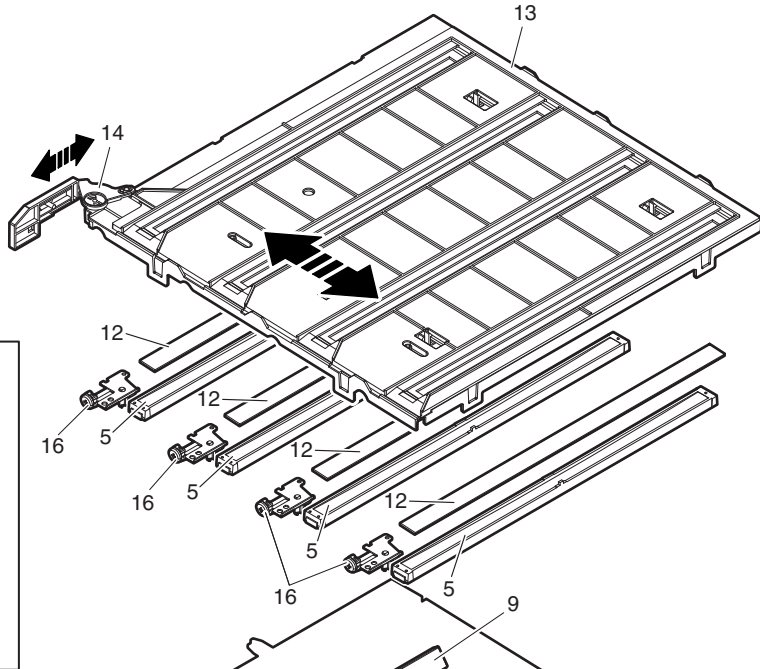
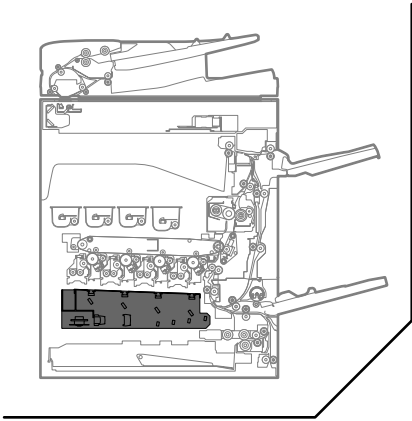

### LSU MOTHER PWB

CN-11	B20B-CZWHK-B-1	10CZ-6H	10CZ-6H
D-GND	B-10		
LVD_PCU	B-9		
RxD_PCU	B-8		
PRTPD_out	B-7		
TRANS_RST	B-6		
TRANS_DAT	B-5		
JOBEND_INT	B-4		
VREF	B-3		
SVD	B-2		
D-GND	B-1		
D-GND	A-1	10CZ-6Y	10CZ-6Y
IRTS_PCU	A-2		
IRTS_PCU	A-3		
ICTS_PCU	A-4		
IPCF	A-5		
LSU_RST	A-6		
SCK	A-7		
TRSV_DAT	A-8		
TH1_LSU	A-9		
D-GND	A-10		

### PCU PWB

CN-2	B20B-CZWHK-B-1
B-1	D-GND
B-2	LVD_PCU
B-3	RxD_PCU
B-4	PRTPD_out
B-5	TRANS_RST
B-6	TRANS_DAT
B-7	JOBEND_INT
B-8	VREF
B-9	SVD
B-10	D-GND
A-10	D-GND
A-9	IRTS_PCU
A-8	IRTS_PCU
A-7	ICTS_PCU
A-6	IPCF
A-5	LSU_RST
A-4	SCK
A-3	TRSV_DAT
A-2	TH1_LSU
A-1	D-GND

### LSU UN (600dpi)

CN-500	TX24-60R-6ST-H1E	WP_KC	1
SDA_KC	51	IRMS_SET_C_on	2
SCL_KC	32	DT_C1+	3
LDCHK_2	33	DT_C1-	4
n_LDERR_Y	34	DT_C2+	5
n_LDERR_C	35	DT_C2-	6
VREF_C	36	DT_K1+	7
IRNB_YMC	37	DT_K1-	8
n_LDERR_K	38	DT_K2+	9
VREF_Y	39	DT_K2-	10
IRSH_C	40	D-GND	11
nSH_Y	41	D-GND	12
VREF_K	42	(NC)	13
IRSH_K	43	(NC)	14
IRNB_K	44	(NC)	15
nSH_M	45	(NC)	16
(NC)	46	(NC)	17
(NC)	47	(NC)	18
(NC)	48	(NC)	19
VREF_M	49	(NC)	20
(NC)	50	TH	21
nLDERR_M	51	D-GND	22
IRSD	52	D-GND	23
D-GND	53	5V_D	24
D-GND	54	D-GND	25
5V_LD	55	D-GND	26
P-GND	56	(NC)	27
P-GND	57	nPOLY_CK	28
+24V	58	nPOLY_LOCK	29
+24V	59	nPOLY_START	30
+3.3V	60		

### LD PWB

CN-2	TX25-60P-6ST-H1E	WP_KC	1
SDA_KC	51	IRMS_SET_C_on	2
SCL_KC	32	DT_C1+	3
LDCHK_2	33	DT_C1-	4
n_LDERR_Y	34	DT_C2+	5
n_LDERR_C	35	DT_C2-	6
VREF_C	36	DT_K1+	7
IRNB_YMC	37	DT_K1-	8
n_LDERR_K	38	DT_K2+	9
VREF_Y	39	DT_K2-	10
IRSH_C	40	D-GND	11
nSH_Y	41	D-GND	12
VREF_K	42	(NC)	13
IRSH_K	43	(NC)	14
IRNB_K	44	(NC)	15
nSH_M	45	(NC)	16
(NC)	46	(NC)	17
(NC)	47	(NC)	18
(NC)	48	(NC)	19
VREF_M	49	(NC)	20
(NC)	50	TH	21
nLDERR_M	51	D-GND	22
IRSD	52	D-GND	23
D-GND	53	5V_D	24
D-GND	54	D-GND	25
5V_LD	55	D-GND	26
P-GND	56	(NC)	27
P-GND	57	nPOLY_CK	28
+24V	58	nPOLY_LOCK	29
+24V	59	nPOLY_START	30
+3.3V	60		

B to B

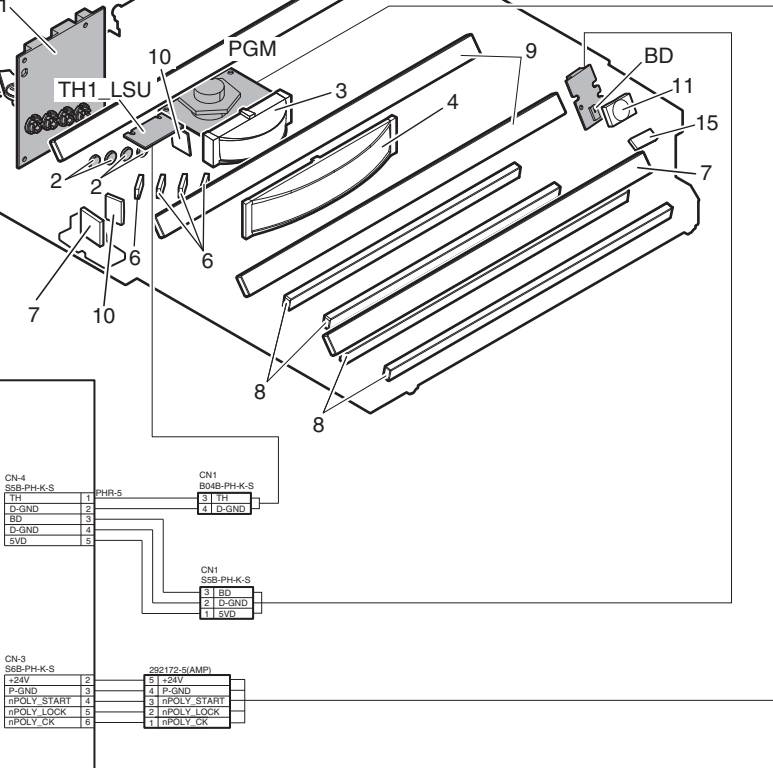

Signal name	Name	Function/Operation
BD	Laser beam detector	Detects (monitors) the laser beam scan timing.
PGM	Polygon motor	Scans laser beams.
TH1_LSU	LSU temperature sensor	Detects the temperature in the LSU. (For correction of the LSU distortion)

No.	Name	Function/Operation
1	LD PWB	Drives the laser diode and controls the power.
2	Collimeter lens	Forms laser beams.
3	f $\theta$ lens 1	Equalizes the laser beam dot intervals in the main scanning direction. (Corrects the laser dot intervals on the OPC drum.)
4	f $\theta$ lens 2	
5	f $\theta$ lens 3	
6	1st mirror	Reflects laser beams to the OPC drum.
7	2nd mirror	Reflects laser beams to the OPC drum.
8	3rd mirror	Reflects laser beams to the OPC drum.
9	4th mirror	Reflects laser beams to the OPC drum.
10	Cylindrical lens	Leads laser beams to the polygon mirror.
11	Conversion lens for BD	Converges laser beams and leads to the BD (Beam Detector).
12	Filter glass	Prevents dust, toner, and foreign materials from entering the LSU.
13	LSU shutter	Closes the exposure opening port in conjunction with opening of the waste toner box, preventing dust, toner, and foreign materials from attaching.
14	Shutter ring cam	Shutter closes the exposure opening port in conjunction with opening of the waste toner box.
15	BD mirror	Leads laser beams to the BD (Beam Detector).
16	Skew adjustment screw (C, M, Y, K)	Adjusts the radiating angle of laser beams for the OPC drum. By turning this adjustment screw, image skew can be adjusted.

(2) 26cpm/31cpm(A) machine

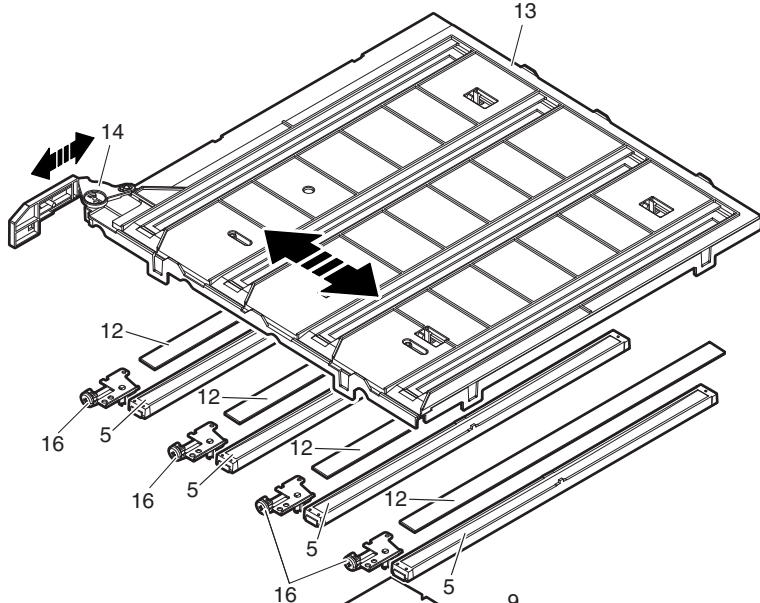
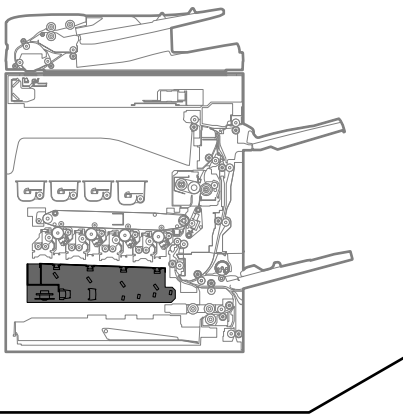

**LSU MOTHER PWB**

CN-11	
B20B-CZVHK-B-1	
D-GND	B-10
TRD_PCU	B-9
RxD_PCU	B-8
PHTRD_0&#224	B-7
TRANS_RST	B-6
TRANS_DAT	B-5
JOSEND_INT	B-4
WV0P	B-3
SVD	B-2
D-GND	B-1
10CZ-6H 10CZ-6H	
D-GND	A-1
nRES_PCU	A-2
nRIS_PCU	A-3
nCTS_PCU	A-4
POP	A-5
LSU_RST	A-6
SCK	A-7
RSV_DAT	A-8
TH1_LSU	A-9
D-GND	A-10

**PCU PWB**

CN-2	
B20B-CZVHK-B-1	
D-GND	B-1
TRD_PCU	B-2
RxD_PCU	B-3
PHTRD_0&#224	B-4
TRANS_RST	B-5
TRANS_DAT	B-6
JOSEND_INT	B-7
WV0P	B-8
SVD	B-9
D-GND	B-10
10CZ-6Y 10CZ-6Y	
D-GND	A-10
nRES_PCU	A-9
nRIS_PCU	A-8
nCTS_PCU	A-7
POP	A-6
LSU_RST	A-5
SCK	A-4
RSV_DAT	A-3
TH1_LSU	A-2
D-GND	A-1

**LSU UN (1200dpi)**

CN-12	
B14B-CZHK-B-1	
AK_RXD_K	1
AK_TRD_K#	2
AK_SCL_K#	3
AK_MS_SET#	4
D-GND	5
AK_CS_EEP_Y#	6
AK_CS_EEP_M#	7
AK_CS_EEP_C#	8
AK_CS_EEP_K#	9
AK_CS_Y#	10
AK_CS_M#	11
AK_CS_C#	12
AK_CS_K#	13
D-GND	14

**LD PWB**

CN-3	
B14B-CZHK-B-1	
AK_RXD_K	14
AK_TRD_K#	13
AK_SCL_K#	12
AK_MS_SET#	11
D-GND	10
AK_CS_EEP_Y#	9
AK_CS_EEP_M#	8
AK_CS_EEP_C#	7
AK_CS_EEP_K#	6
AK_CS_Y#	5
AK_CS_M#	4
AK_CS_C#	3
AK_CS_K#	2
D-GND	1

**LSU UN (1200dpi)**

CN-500	
TX24-80R-6ST-H1E	
WP_KC	1
nMS_SET_C_on	2
DT_C1+	3
nMS_SET_M_on	4
DT_C1-	4
DT_C2+	5
nLDERR_C	6
DT_C2-	6
P4(ENB)_K	7
DT_K1+	7
DT_K1-	8
DT_K2+	9
DT_K2-	10
P4(ENB)_M	11
P4(ENB)_Y	11
P3(WAIT)_K	12
P3(WAIT)_C	12
DT_Y1+	13
P3(WAIT)_M	13
DT_Y1-	14
DT_Y2+	15
DT_Y2-	16
DT_M1+	17
DT_M1-	18
DT_M2+	19
DT_M2-	20
CS_K	21
nLDERR_M	22
D-GND	22
nBD	23
D-GND	23
+5VLD	24
D-GND	24
nPOLY_LOCK	25
D-GND	25
P-GND	26
D-GND	26
nPOLY_CK	28
D-GND	28
+24V1	29
D-GND	29
+3.3V	30
D-GND	30
nSDCLK	31
D-GND	31
nMS_SET_K	32
D-GND	32
nRXD	33
D-GND	33
nSCLK	34
D-GND	34
nINT_K	35
D-GND	35
nINT_M	36
D-GND	36
nINT_Y	37
D-GND	37
nINT_C	38
D-GND	38
nINT_M	39
D-GND	39
nINT_Y	40
D-GND	40
SDA_MY	80

**LD PWB**

CN-2	
TX25-80P-6ST-H1E	
WP_KC	1
nMS_SET_C_on	2
DT_C1+	3
DT_C1-	4
DT_C2+	5
DT_C2-	6
DT_K1+	7
DT_K1-	8
DT_K2+	9
DT_K2-	10
D-GND	11
D-GND	11
D-GND	12
D-GND	12
DT_Y1+	13
DT_Y1-	14
DT_Y2+	15
DT_Y2-	16
DT_M1+	17
DT_M1-	18
DT_M2+	19
DT_M2-	20
TH	21
D-GND	22
D-GND	22
+5VLD	23
D-GND	23
nPOLY_LOCK	24
D-GND	24
nPOLY_CK	25
D-GND	25
nMS_SET_Y_on	26
D-GND	26
nPOLY_START	27
D-GND	27
nPOLY_LOCK	28
D-GND	28
nPOLY_START	29
D-GND	29
+24V1	30
D-GND	30
CS_EEP_C	31
D-GND	31
CS_EEP_M	32
D-GND	32
CS_EEP_Y	33
D-GND	33
CS_C	34
D-GND	34
CS_M	35
D-GND	35
CS_Y	36
D-GND	36
WP_MY	37
D-GND	37
FAN_READY	38
D-GND	38
FAN_PWM(24V)	39
D-GND	39
nINT_Y	40
D-GND	40
SCL_MY	80

**LD PWB**

CN-4	
SSB-PHK-S	
TH	1
D-GND	2
BU	3
D-GND	4
SVD	5

**LD PWB**

CN-1	
8048-PHK-S	
TH	1
D-GND	2
D-GND	3
D-GND	4

**LD PWB**

CN-3	
SSB-PHK-S	
(NC)(NC)	1
+24V	2
P-GND	3
nPOLY_START	4
nPOLY_LOCK	5
nPOLY_CK	6

**LD PWB**

292173-(S)AMP	
5	1
4	2
3	3
2	4
1	5



Signal name	Name	Function/Operation
BD	Laser beam detector	Detects (monitors) the laser beam scan timing.
PGM	Polygon motor	Scans laser beams.
TH1_LSU	LSU temperature sensor	Detects the temperature in the LSU. (For correction of the LSU distortion)

No.	Name	Function/Operation
1	LD PWB	Drives the laser diode and controls the power.
2	Collimeter lens	Forms laser beams.
3	f $\theta$ lens 1	Equalizes the laser beam dot intervals in the main scanning direction. (Corrects the laser dot intervals on the OPC drum.)
4	f $\theta$ lens 2	
5	f $\theta$ lens 3	
6	1st mirror	Reflects laser beams to the OPC drum.
7	2nd mirror	Reflects laser beams to the OPC drum.
8	3rd mirror	Reflects laser beams to the OPC drum.
9	4th mirror	Reflects laser beams to the OPC drum.
10	Cylindrical lens	Leads laser beams to the polygon mirror.
11	Conversion lens for BD	Converges laser beams and leads to the BD (Beam Detector).
12	Filter glass	Prevents dust, toner, and foreign materials from entering the LSU.
13	LSU shutter	Closes the exposure opening port in conjunction with opening of the waste toner box, preventing dust, toner, and foreign materials from attaching.
14	Shutter ring cam	Shutter closes the exposure opening port in conjunction with opening of the waste toner box.
15	BD mirror	Leads laser beams to the BD (Beam Detector).
16	Skew adjustment screw (C, M, Y, K)	Adjusts the radiating angle of laser beams for the OPC drum. By turning this adjustment screw, image skew can be adjusted.



**(3) 36cpm machine**

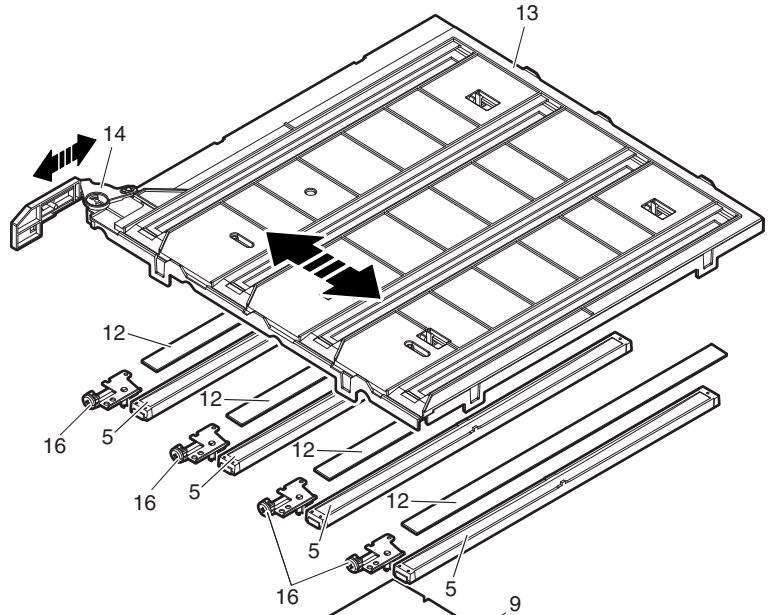
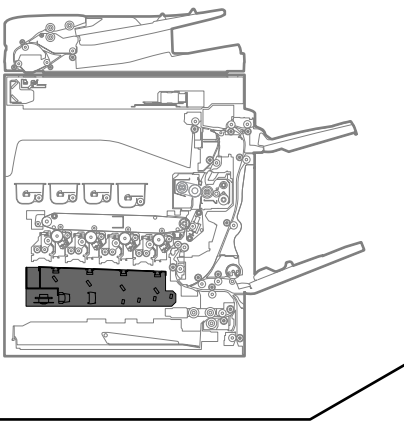

**LSU MOTHER PWB**

CN-11	
B20B-CZWHK-B-1	
D-GND	B-10
TXD_PCU	B-9
RxD_PCU	B-8
PHYPD_S&#228	B-7
TRANS_RST	B-6
TRANS_DAT	B-5
JOBEND_INT	B-4
WVP	B-3
SVD	B-2
D-GND	B-1

10CZ-6H	10CZ-6H
10CZ-6Y	10CZ-6Y
D-GND	A-1
nRES_PCU	A-2
nRTS_PCU	A-3
nCTS_PCU	A-4
PCP	A-5
LSU_RST	A-6
SCK	A-7
RSV_DAT	A-8
TH1_LSU	A-9
D-GND	A-10

**PCU PWB**

CN-2	
B20B-CZWHK-B-1	
B-1	D-GND
B-2	TXD_PCU
B-3	RxD_PCU
B-4	PHYPD_S&#228
B-5	TRANS_RST
B-6	TRANS_DAT
B-7	JOBEND_INT
B-8	WVP
B-9	SVD
B-10	D-GND

CN-12	
B14B-CZHK-B-1	
AK_RXD_K	1
AK_TXD_K#	2
AK_SCLK#	3
AK_MS_SET#	4
D-GND	5
AK_CS_EEP_Y#	6
AK_CS_EEP_M#	7
AK_CS_EEP_C#	8
AK_CS_EEP_K#	9
AK_CS_Y#	10
AK_CS_M#	11
AK_CS_C#	12
AK_CS_K#	13
D-GND	14

14CZ-6H	14CZ-6H
14CZ-6Y	14CZ-6Y
AK_RXD_K	14
AK_TXD_K#	13
AK_SCLK#	12
AK_MS_SET#	11
D-GND	10
AK_CS_EEP_Y#	9
AK_CS_EEP_M#	8
AK_CS_EEP_C#	7
AK_CS_EEP_K#	6
AK_CS_Y#	5
AK_CS_M#	4
AK_CS_C#	3
AK_CS_K#	2
D-GND	1

CN-500	
TX24-80R-6ST-H1E	
WP_KC	1
nMS_SET_C_on	2
DT_C1+	3
nMS_SET_M_on	4
DT_C1-	5
nLDERR_C	6
DT_C2+	7
nLDERR_K	8
DT_K1+	9
nLDERR_Y	10
DT_K2+	11
nLDERR_M	12
DT_K1-	13
nLDERR_Y	14
DT_K2-	15
nLDERR_C	16
DT_Y1+	17
nLDERR_M	18
DT_Y2+	19
nLDERR_C	20
DT_M1+	21
nLDERR_M	22
DT_M2+	23
nLDERR_C	24
DT_M1-	25
nLDERR_M	26
DT_M2-	27
nLDERR_C	28
DT_Y1-	29
nLDERR_M	30
DT_Y2-	31
nLDERR_C	32
DT_C1+	33
nLDERR_Y	34
DT_C1-	35
nLDERR_K	36
DT_C2+	37
nLDERR_M	38
DT_C2-	39
nLDERR_C	40
DT_K1+	41
nLDERR_Y	42
DT_K1-	43
nLDERR_C	44
DT_K2+	45
nLDERR_M	46
DT_K2-	47
nLDERR_C	48
DT_Y1+	49
nLDERR_Y	50
DT_Y1-	51
nLDERR_C	52
DT_Y2+	53
nLDERR_M	54
DT_Y2-	55
nLDERR_C	56
DT_M1+	57
nLDERR_M	58
DT_M1-	59
nLDERR_C	60
DT_M2+	61
nLDERR_M	62
DT_M2-	63
nLDERR_C	64
DT_C1+	65
nLDERR_Y	66
DT_C1-	67
nLDERR_K	68
DT_C2+	69
nLDERR_M	70
DT_C2-	71
nLDERR_C	72
DT_Y1+	73
nLDERR_Y	74
DT_Y1-	75
nLDERR_C	76
DT_Y2+	77
nLDERR_M	78
DT_Y2-	79
nLDERR_C	80

CN-2	
TX25-80P-6ST-H1E	
WP_KC	1
nMS_SET_C_on	2
DT_C1+	3
nMS_SET_M_on	4
DT_C1-	5
nLDERR_C	6
DT_C2+	7
nLDERR_K	8
DT_K1+	9
nLDERR_Y	10
DT_K2+	11
nLDERR_M	12
DT_K1-	13
nLDERR_Y	14
DT_K2-	15
nLDERR_C	16
DT_Y1+	17
nLDERR_M	18
DT_Y2+	19
nLDERR_C	20
DT_M1+	21
nLDERR_M	22
DT_M2+	23
nLDERR_C	24
DT_M1-	25
nLDERR_M	26
DT_M2-	27
nLDERR_C	28
DT_Y1-	29
nLDERR_M	30
DT_Y2-	31
nLDERR_C	32
DT_C1+	33
nLDERR_Y	34
DT_C1-	35
nLDERR_K	36
DT_C2+	37
nLDERR_M	38
DT_C2-	39
nLDERR_C	40
DT_K1+	41
nLDERR_Y	42
DT_K1-	43
nLDERR_C	44
DT_K2+	45
nLDERR_M	46
DT_K2-	47
nLDERR_C	48
DT_Y1+	49
nLDERR_Y	50
DT_Y1-	51
nLDERR_C	52
DT_Y2+	53
nLDERR_M	54
DT_Y2-	55
nLDERR_C	56
DT_M1+	57
nLDERR_M	58
DT_M1-	59
nLDERR_C	60
DT_M2+	61
nLDERR_M	62
DT_M2-	63
nLDERR_C	64
DT_C1+	65
nLDERR_Y	66
DT_C1-	67
nLDERR_K	68
DT_C2+	69
nLDERR_M	70
DT_C2-	71
nLDERR_C	72
DT_Y1+	73
nLDERR_Y	74
DT_Y1-	75
nLDERR_C	76
DT_Y2+	77
nLDERR_M	78
DT_Y2-	79
nLDERR_C	80

**LSU UN (1200dpi)**

CN-2	
TX25-80P-6ST-H1E	
WP_KC	1
nMS_SET_C_on	2
DT_C1+	3
nMS_SET_M_on	4
DT_C1-	5
nLDERR_C	6
DT_C2+	7
nLDERR_K	8
DT_K1+	9
nLDERR_Y	10
DT_K2+	11
nLDERR_M	12
DT_K1-	13
nLDERR_Y	14
DT_K2-	15
nLDERR_C	16
DT_Y1+	17
nLDERR_M	18
DT_Y2+	19
nLDERR_C	20
DT_M1+	21
nLDERR_M	22
DT_M2+	23
nLDERR_C	24
DT_M1-	25
nLDERR_M	26
DT_M2-	27
nLDERR_C	28
DT_Y1-	29
nLDERR_M	30
DT_Y2-	31
nLDERR_C	32
DT_C1+	33
nLDERR_Y	34
DT_C1-	35
nLDERR_K	36
DT_C2+	37
nLDERR_M	38
DT_C2-	39
nLDERR_C	40
DT_K1+	41
nLDERR_Y	42
DT_K1-	43
nLDERR_C	44
DT_K2+	45
nLDERR_M	46
DT_K2-	47
nLDERR_C	48
DT_Y1+	49
nLDERR_Y	50
DT_Y1-	51
nLDERR_C	52
DT_Y2+	53
nLDERR_M	54
DT_Y2-	55
nLDERR_C	56
DT_M1+	57
nLDERR_M	58
DT_M1-	59
nLDERR_C	60
DT_M2+	61
nLDERR_M	62
DT_M2-	63
nLDERR_C	64
DT_C1+	65
nLDERR_Y	66
DT_C1-	67
nLDERR_K	68
DT_C2+	69
nLDERR_M	70
DT_C2-	71
nLDERR_C	72
DT_Y1+	73
nLDERR_Y	74
DT_Y1-	75
nLDERR_C	76
DT_Y2+	77
nLDERR_M	78
DT_Y2-	79
nLDERR_C	80

**LD PWB**

CN-4	
S8B-PHK-S	
TH	1
D-GND	2
BU	3
D-GND	4
SVD	5

CN-1	
S8B-PHK-S	
TH	3
D-GND	4
SVD	5

CN-3	
S8B-PHK-S	
INC(INC)	1
+24V	2
P-GND	3
nPOLY_START	4
nPOLY_LOCK	5
nPOLY_CK	6



Signal name	Name	Function/Operation
BD	Laser beam detector	Detects (monitors) the laser beam scan timing.
LSUFM	LSU cooling fan	Cools the LSU.
PGM	Polygon motor	Scans laser beams.
TH1_LSU	LSU temperature sensor	Detects the temperature in the LSU. (For correction of the LSU distortion)

No.	Name	Function/Operation
1	LD PWB	Drives the laser diode and controls the power.
2	Collimeter lens	Forms laser beams.
3	f $\theta$ lens 1	Equalizes the laser beam dot intervals in the main scanning direction. (Corrects the laser dot intervals on the OPC drum.)
4	f $\theta$ lens 2	
5	f $\theta$ lens 3	
6	1st mirror	Reflects laser beams to the OPC drum.
7	2nd mirror	Reflects laser beams to the OPC drum.
8	3rd mirror	Reflects laser beams to the OPC drum.
9	4th mirror	Reflects laser beams to the OPC drum.
10	Cylindrical lens	Leads laser beams to the polygon mirror.
11	Conversion lens for BD	Converges laser beams and leads to the BD (Beam Detector).
12	Filter glass	Prevents dust, toner, and foreign materials from entering the LSU.
13	LSU shutter	Closes the exposure opening port in conjunction with opening of the waste toner box, preventing dust, toner, and foreign materials from attaching.
14	Shutter ring cam	Shutter closes the exposure opening port in conjunction with opening of the waste toner box.
15	BD mirror	Leads laser beams to the BD (Beam Detector).
16	Skew adjustment screw (C, M, Y, K)	Adjusts the radiating angle of laser beams for the OPC drum. By turning this adjustment screw, image skew can be adjusted.

## B. Operational descriptions

### (1) General

Image data sent from the LSU Mother PWB are converted into laser beams and radiated onto the OPC drum surface. The LSU unit is composed of : (1) the optical elements from the laser to the polygon mirror, (2) the primary system including the mirror which secures the optical path, (3) the optical elements including the polygon mirror, and (4) the scanning system including the mirror which secure the optical path.

### (2) Composition

#### Primary system

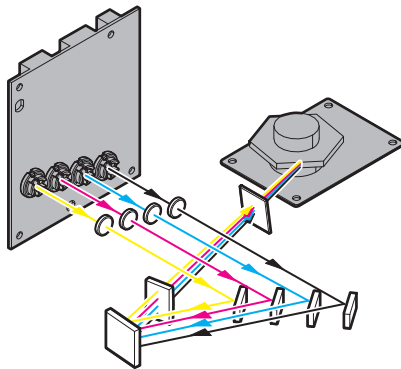

#### Scanning system

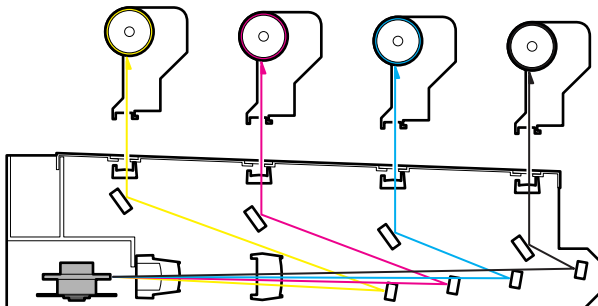

#### Main scanning direction

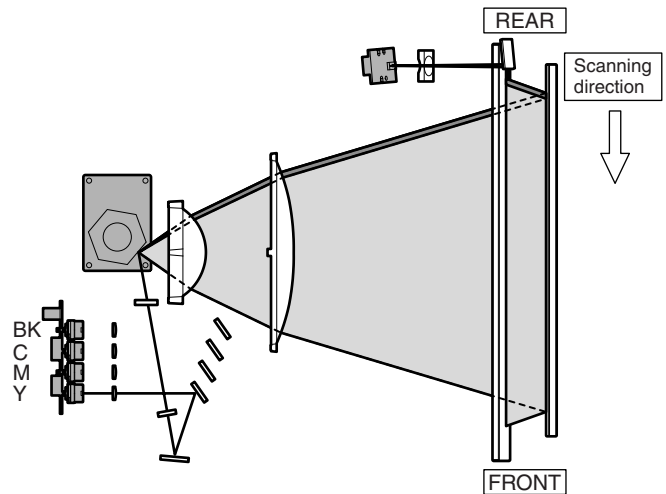

#### Writing position on paper

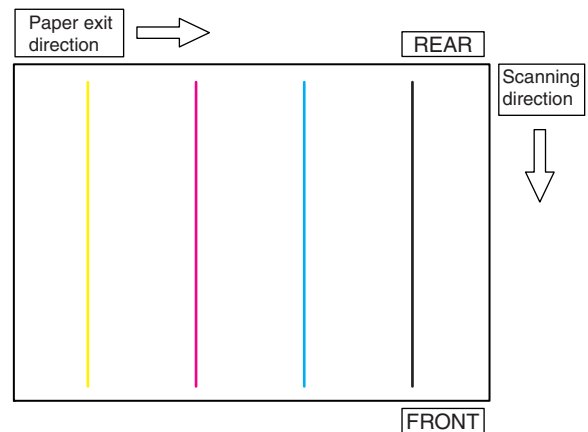

### (3) Outline of LSU specifications

#### 18cpm/20cpm/23cpm machine

Process speed	104mm/sec
Resolution	600dpi
Laser beam	Single
Polygon motor rotation speed	24566.9rpm
Laser power	0.164mW
Bearing type	Oil bearing
Number of mirrors	6
Laser beam diameter	50 - 85 x 50 - 80 $\mu$ m
Effective scan length	310mm
Laser wave length	790 $\pm$ 10nm

#### 31cpm(G) machine

Process speed	140mm/sec
Resolution	600dpi
Laser beam	Single
Polygon motor rotation speed	33070.9rpm
Laser power	0.220mW
Bearing type	Oil bearing
Number of mirrors	6
Laser beam diameter	50 - 85 x 50 - 80 $\mu$ m
Effective scan length	310mm
Laser wave length	790 $\pm$ 10nm

#### 26cpm/31cpm(A) machine

Process speed	140mm/sec
Resolution	1200dpi
Laser beam	2 beams
Polygon motor rotation speed	33070.9rpm
Laser power	0.110mW
Bearing type	Oil bearing
Number of mirrors	6
Laser beam diameter	50 - 85 x 50 - 80 $\mu$ m
Effective scan length	310mm
Laser wave length	790 $\pm$ 10nm

#### 36cpm machine

Process speed	165mm/sec
Resolution	1200dpi
Laser beam	2 beams
Polygon motor rotation speed	38976.4rpm
Laser power	0.130mW
Bearing type	Oil bearing
Number of mirrors	6
Laser beam diameter	50 - 85 x 50 - 80 $\mu$ m
Effective scan length	310mm
Laser wave length	790 $\pm$ 10nm

## 9. Process section

### A. General

The process section is composed of the following major devices.

Laser beams generated by the LSU are converted into visible toner images via the OPC drum, the developing unit, and the transfer unit, and transferred on paper.

The process operations are performed in the following sequence:

Charging - Exposure - Developing - Primary transfer - Secondary transfer

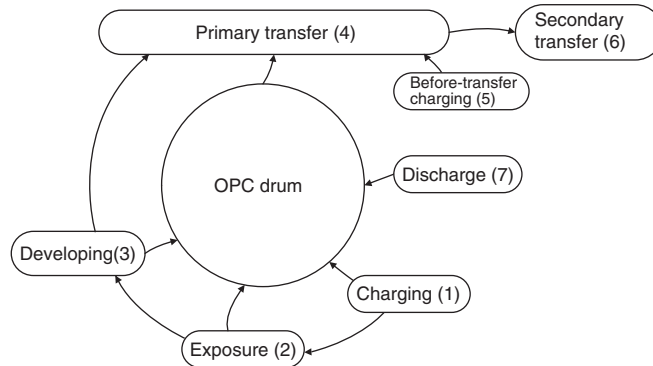

In addition, the process control system is employed to maintain stable print image qualities.

### B. Major units and functions

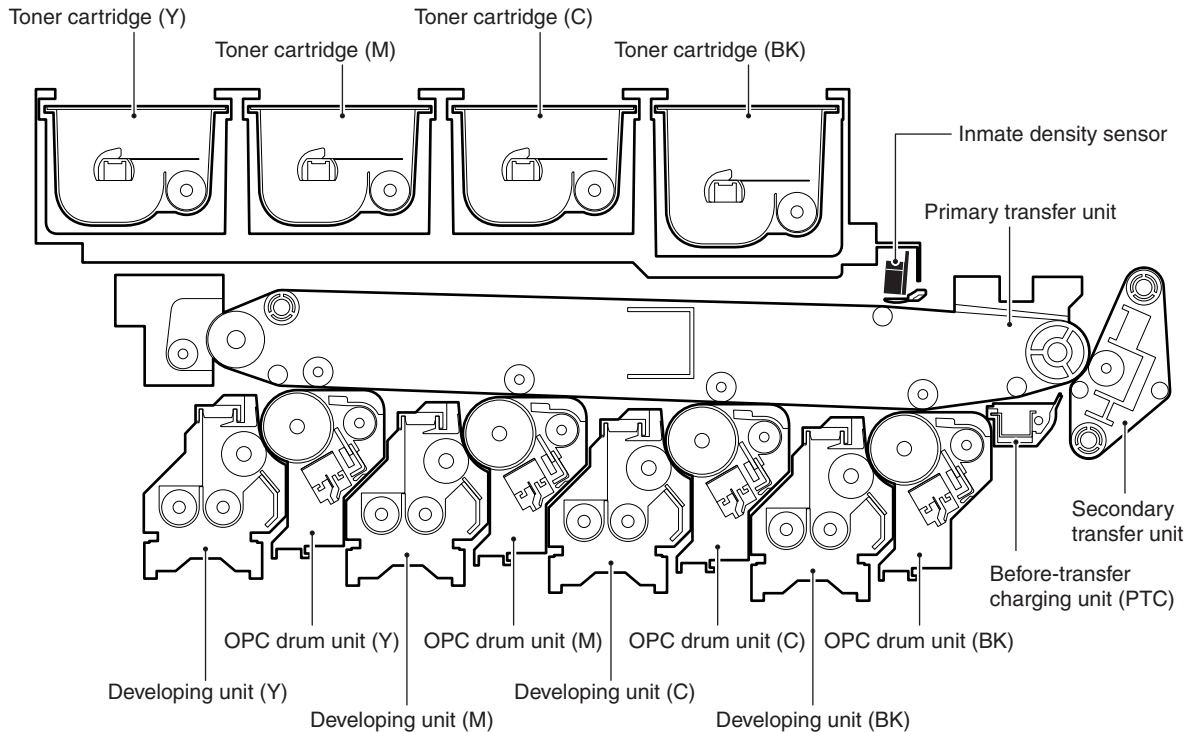

Name	Content
OPC drum unit	Generates electrostatic latent images with the main charger and the image laser beams.
Toner cartridge	Supplies toner to the developing unit with the toner motor.
Developing unit	Converts electrostatic latent images on the OPC drum into visible toner images.
Primary transfer unit	Transfers toner images on the OPC drum to the primary transfer belt.
Secondary transfer unit	Transfers toner images from the primary transfer belt to paper.
Waste toner collection section	Collects waste toner generated in the OPC drum section and the transfer section.
Image density sensor (Registration sensor)	Detects the toner patch density on the primary transfer belt during operation of the process control system. Detects the color shift amount.
MC/DV PWB	Generates the main charger voltage and the DV bias voltage.
TC PWB	Generates the transfer voltage.
Before-transfer charging unit (PTC)	Charges toner so as to be easily transferred on paper.

**C. Process section equivalent circuit diagram**

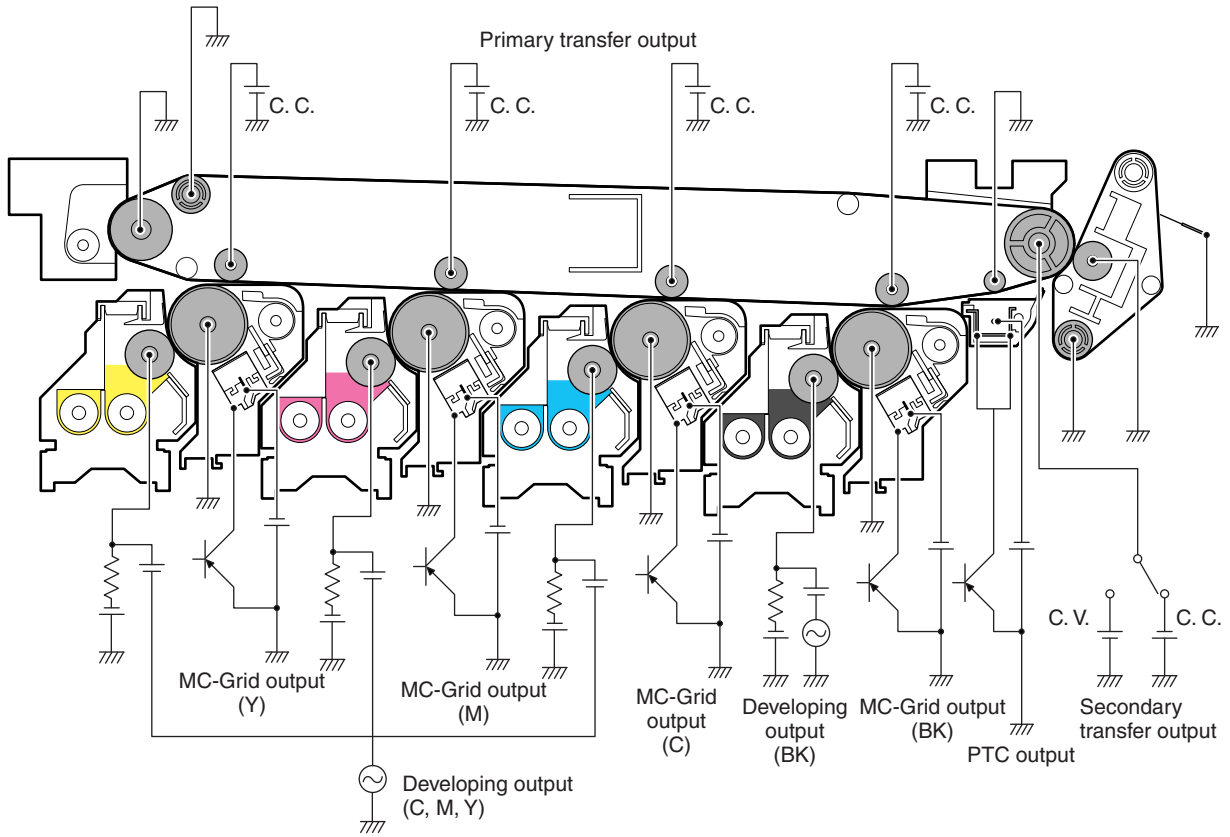

## D. Process control

### (1) General

The process control system is provided to maintain stable print image qualities under changes in the environmental conditions and in characteristics of supply parts.

The major operation of the process control is to detect a change in the print density with the image density sensor and change the DV bias, the MC grid voltage and the dither pattern according to the detection result, maintaining the stable color balance and the print density.

### (2) Block diagram

The process control system is composed as shown in the block diagram below.

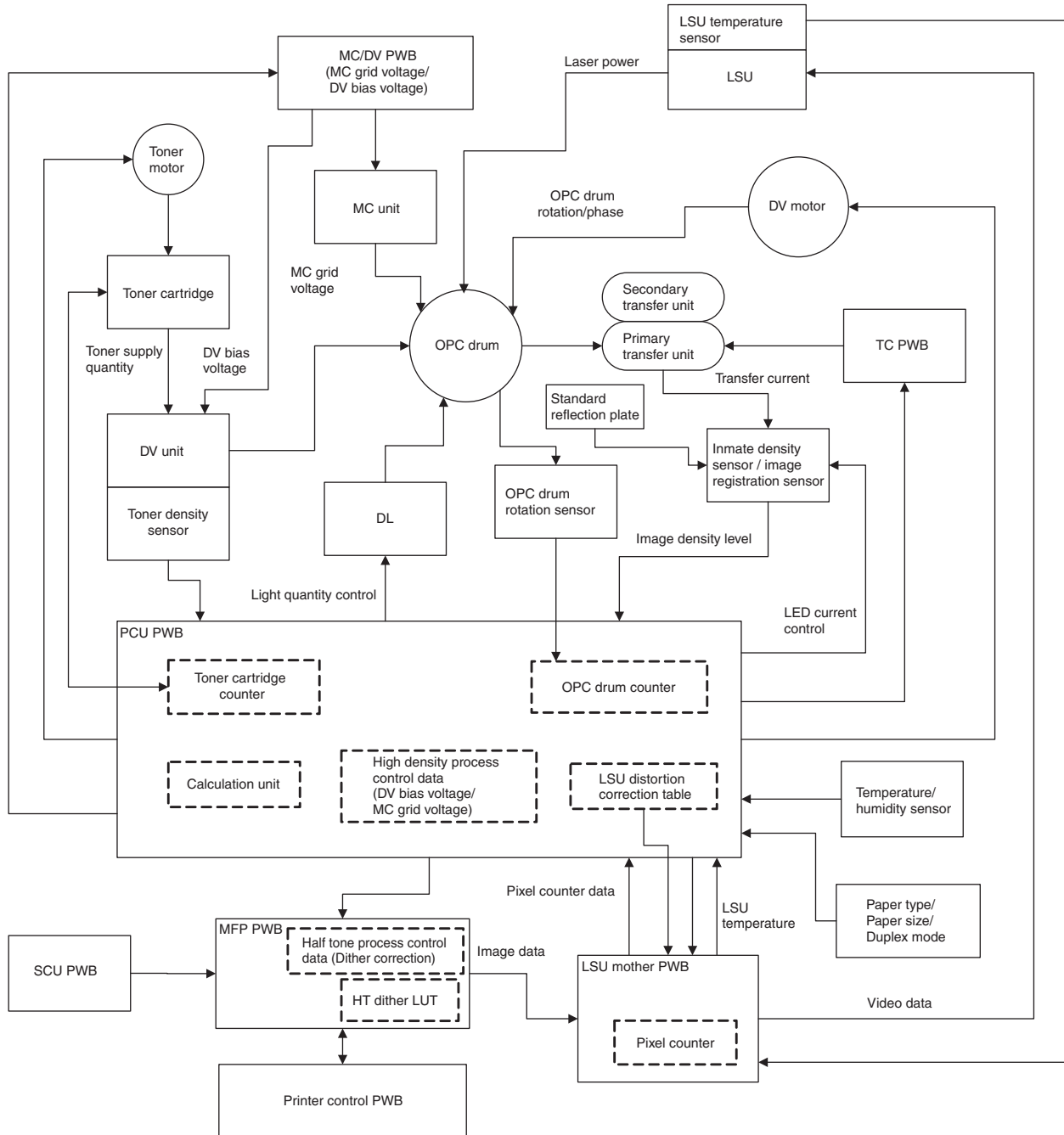

### (3) Process control items and contents

The table below shows the correction item, the change item, the purpose/effect, and the operation timing for each process control item.

Item No.	Correction item		Change item	Purpose/Effect	Operation timing/ Operation condition
1	Color image density sensor calibration (Image registration sensor F)	Color image density sensor LED current adjustment target level setting	<ul style="list-style-type: none"> <li>Relation between the calibration sheet (jig) and the standard reflection plate</li> <li>Color image density sensor LED current adjustment target level</li> </ul>	The color image density sensor LED current adjustment target level is set in order to detect the absolute density.	SIM44-13/44-61
2	Color image density sensor sensitivity adjustment (Image registration sensor F)	Color image density sensor (Image registration sensor F) LED current adjustment	Color image density sensor LED current adjustment value	A change in the sensitivity due to dirt on the sensor or a change in the temperature is corrected to enable always correct detection of the image patch density.	SIM44-2 / Before high density process control operation
	Monochrome image density sensor sensitivity adjustment (Image registration sensor R)	Monochrome image density sensor (Image registration sensor R) LED current adjustment	Monochrome image density sensor amp gain and sensor LED current adjustment value	A change in the sensitivity due to dirt on the sensor or a change in the temperature is corrected to enable always correct detection of the image patch density.	SIM44-2 / Before high density process control operation
3	High density process control	Developing bias voltage correction	Developing bias voltage	A change in the density due to a change in characteristics of the image generating section and overlap copy are prevented to maintain the density in the high density image section at the proper level.	<p>SIM44-6 (Compulsory execution)</p> <p>When warming up after resetting the OPC drum counter, the developing counter, and the transfer counter (SIM25-2/24-4/24-5/24-7).</p> <p>When warming up after resetting the OPC drum counter, the developing counter, and the transfer counter (SIM25-2/24-4/24-5/24-7).</p> <p>When warming up after replacement of the toner cartridge.</p> <p>For the other operation timing, conform to the setting of SIM44-28.</p>
		Main charger grid voltage correction	Main charger grid voltage 3	The developing bias voltage correction (change) is corrected to maintain the relation between the developing bias voltage and the main charger grid voltage difference to a constant one. (Prevention of overlap copy and developer drop)	After the developing bias voltage changes by the high density process control.
4	Half-tone process control	Half-tone process control (Copy mode)	Dither pattern (LUT)	The color balance (gamma) adjusted by the serviceman color balance adjustment is maintained.	<p>1) SIM44-26 (Compulsory execution)</p> <p>2) After the high density process control (However, depending on the conditions)</p> <p>For the other operation timing, conform to the setting of SIM44-28.</p>
		Half-tone process control (Printer mode)	Dither pattern (LUT)	The result of the half-tone correction executed in the copy mode is applied to the printer mode.	After the copy mode half-tone density image correction

Item No.	Correction item		Change item	Purpose/Effect	Operation timing/ Operation condition
5	Toner density correction / Toner density control	Correction for the environmental toner supply quantity (Toner density correction) (Temperature and humidity change)	Toner supply quantity (Toner supply time)	By changing the toner motor rotation level, the toner supply is corrected to maintain the toner density at a proper level.	When the temperature and the humidity change
		Toner supply quantity correction for the result of the high density process control	Toner supply quantity (Toner supply time)	When the developing bias voltage is changed by the high density process control, if the toner density is judged to be low, the toner supply quantity is corrected to maintain the proper density for print.	After the developing bias voltage is changed to the higher level than the specified level by the high density process control.
		Correction of the toner supply quantity for the toner cartridge counter	Toner motor rotation number Toner supply quantity (Toner supply time)	The toner supply quantity to the developing unit for the certain number of rotations of the toner motor differs depending on the remaining toner quantity in the toner cartridge. Therefore, the toner motor RPM is changed according to the remaining toner quantity (toner motor counter) to maintain the proper toner supply operation.	When the toner motor counter changes
		Correction of the toner supply quantity for the output image density (number of pixels)	Toner supply quantity (Toner supply time (duty))	The toner supply quantity is maintained properly for the area (pixel count) of output images (for the actual toner consumption quantity), keeping the toner density at the proper level.	During output operation (for every page)



#### (4) Operational descriptions

##### a. Image density sensor sensitivity adjustment operation

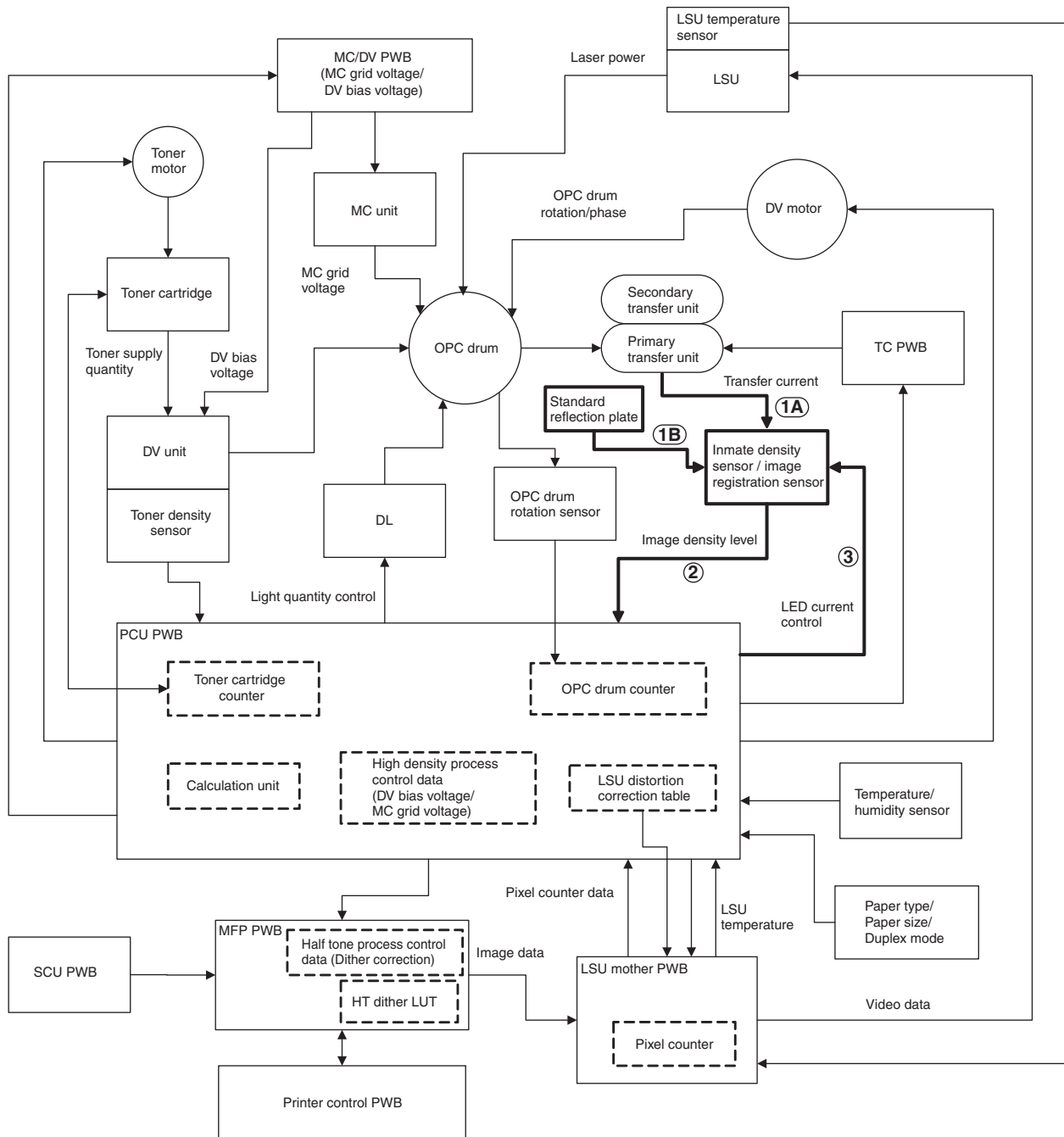

**Color image density sensor (image registration sensor F) sensitivity adjustment operation**

When the machine enters the adjustment operation, the primary transfer unit enters the free mode. In conjunction with this operations, the standard reflection plate is rotated and shifted to the front of the sensor by the lever mechanism.

The sensor sensitivity adjustment is executed by using the standard reflection plate.

The adjustment operation means the operation which seeks for the LED current to obtain the specified output level pf the sensor.

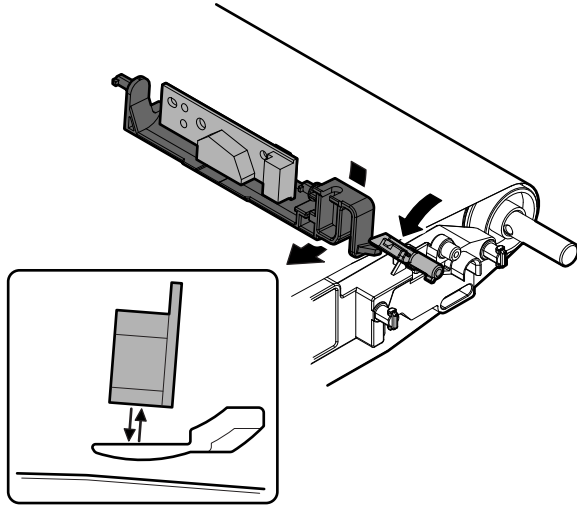

**Black image density sensor (image registration R) sensitivity adjustment operation**

When the machine enters the adjustment operation, the primary transfer unit enters the print mode to perform the sensor sensitivity adjustment by using the surface reflection of the primary transfer belt.

The adjustment operation means the operation which seeks for the LED current to obtain the specified output level pf the sensor.

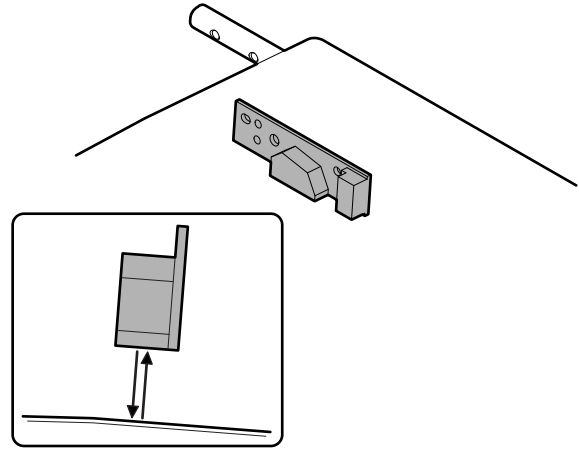

**b. High density process control operation (Toner patch generation and density correction operations)**

- 1) When the machine enters the high density process control mode, the secondary transfer unit enters the free state.
- 2) While changing the DV bias voltage step by step, a number of toner patches in different densities are generated on the F side and the R side of the primary transfer belt.

F side: The color toner patch is generated.  
R side: The black toner patch is generated.

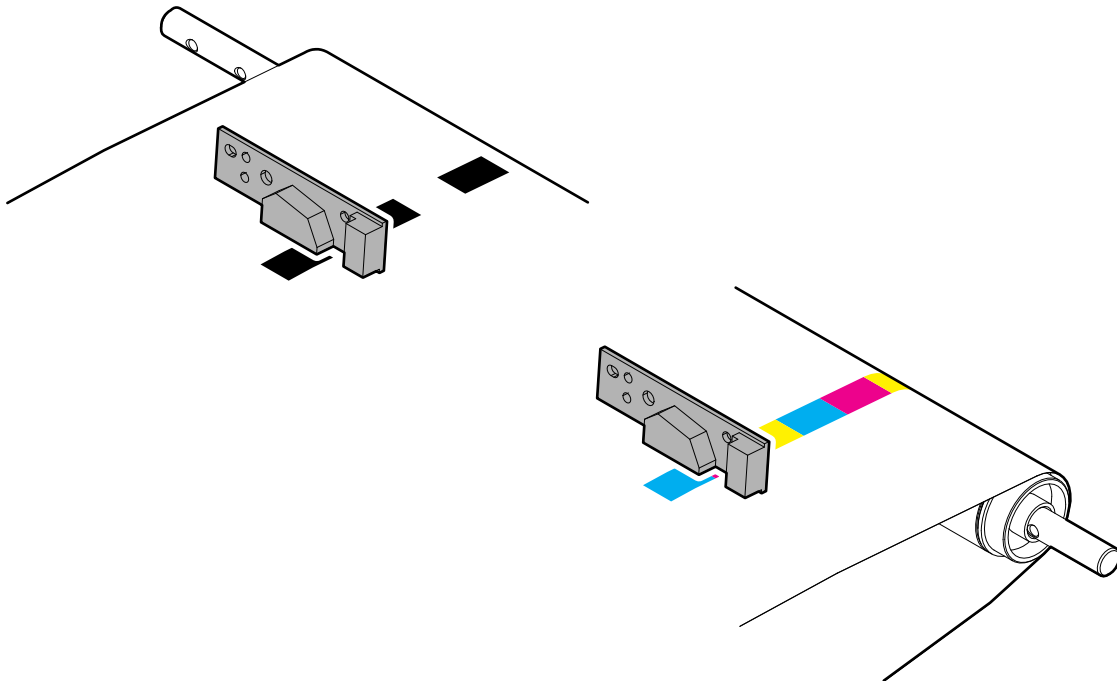

- 3) Each toner patch density is detected by the image density sensor, and the DV bias correction voltage is calculated in the PCU PWB so that the proper density is obtained from the relation between the DV bias voltage at the time when each toner patch is made and the toner patch density.

## Operation flow

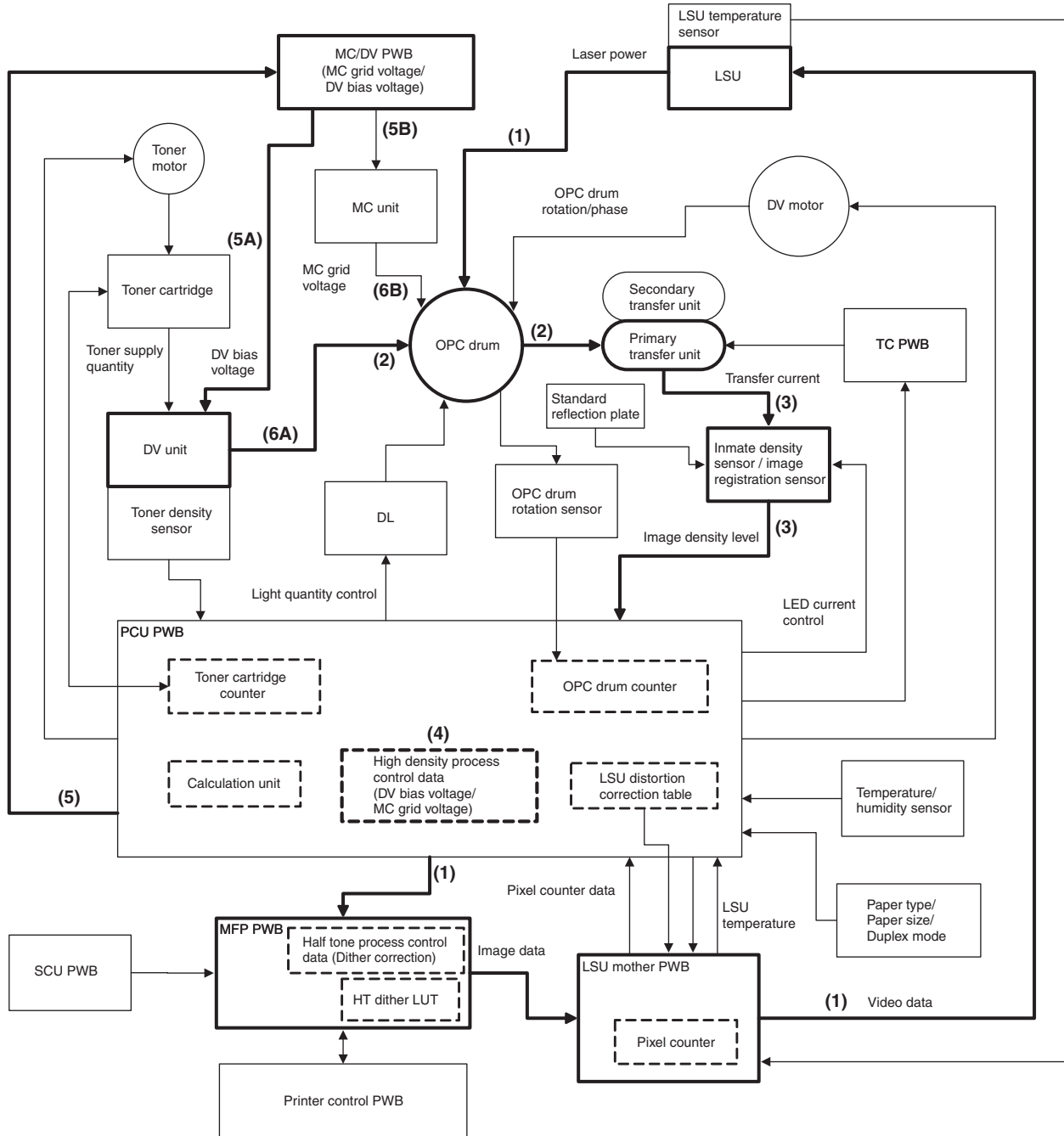

- (1) Toner patch electrostatic latent images are formed on the OPC drum.
- (2) The toner patch electrostatic latent images are developed and transferred on the primary transfer belt.
- (3) Each toner patch density is detected by the toner density sensor.
- (4) The DV bias correction value is calculated.
- (5) The DV bias correction value is applied to the actual operation mode.
- (6) The calculated DV bias voltage is applied to the actual operation mode.

**c. Half-tone process control operation (Toner patch generation and half-tone correction operation)**

- 1) When the machine enters the half-tone process control mode, the secondary transfer unit enters the free state.
- 2) While changing the dither pattern step by step by the MFP PWB, a number of toner patches in different densities are generated on the F side and the R side of the primary transfer belt.

F side: The color toner patch is generated.

R side: The black toner patch is generated.

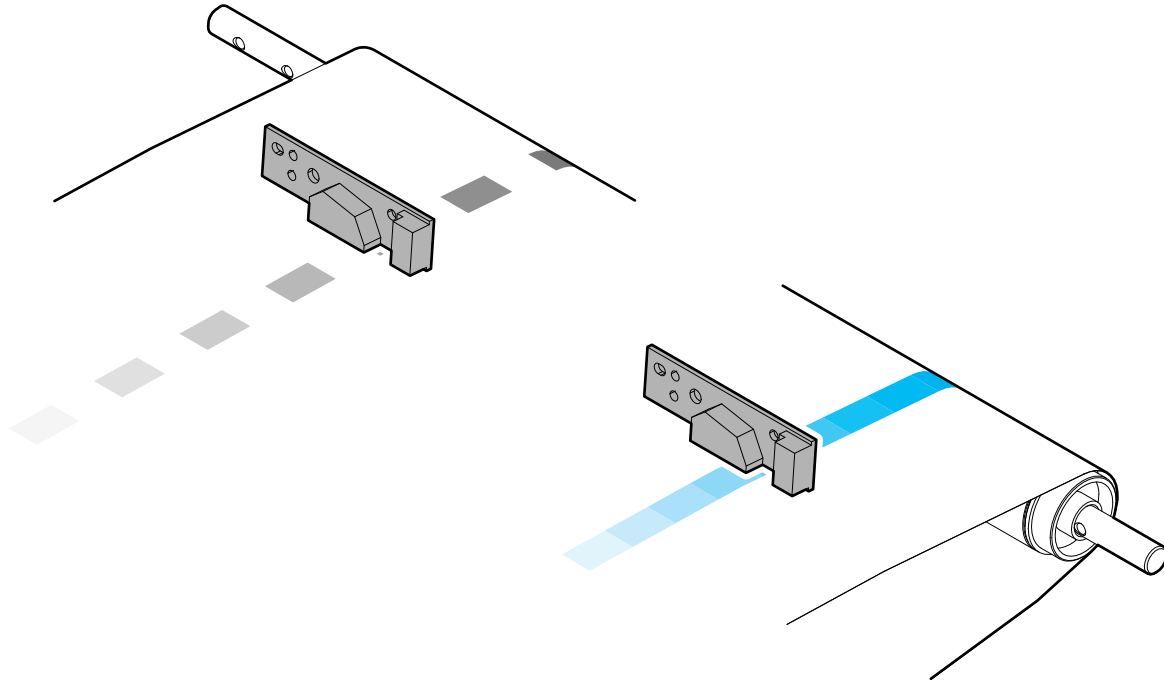

- 3) Each toner patch density is detected by the image density sensor, and each toner patch density are compared with the reference gamma to calculate the correction amount.
- 4) The dither pattern in the actual operation mode is generated in the MFP PWB with the reference gamma and the correction amount.

## Operation flow

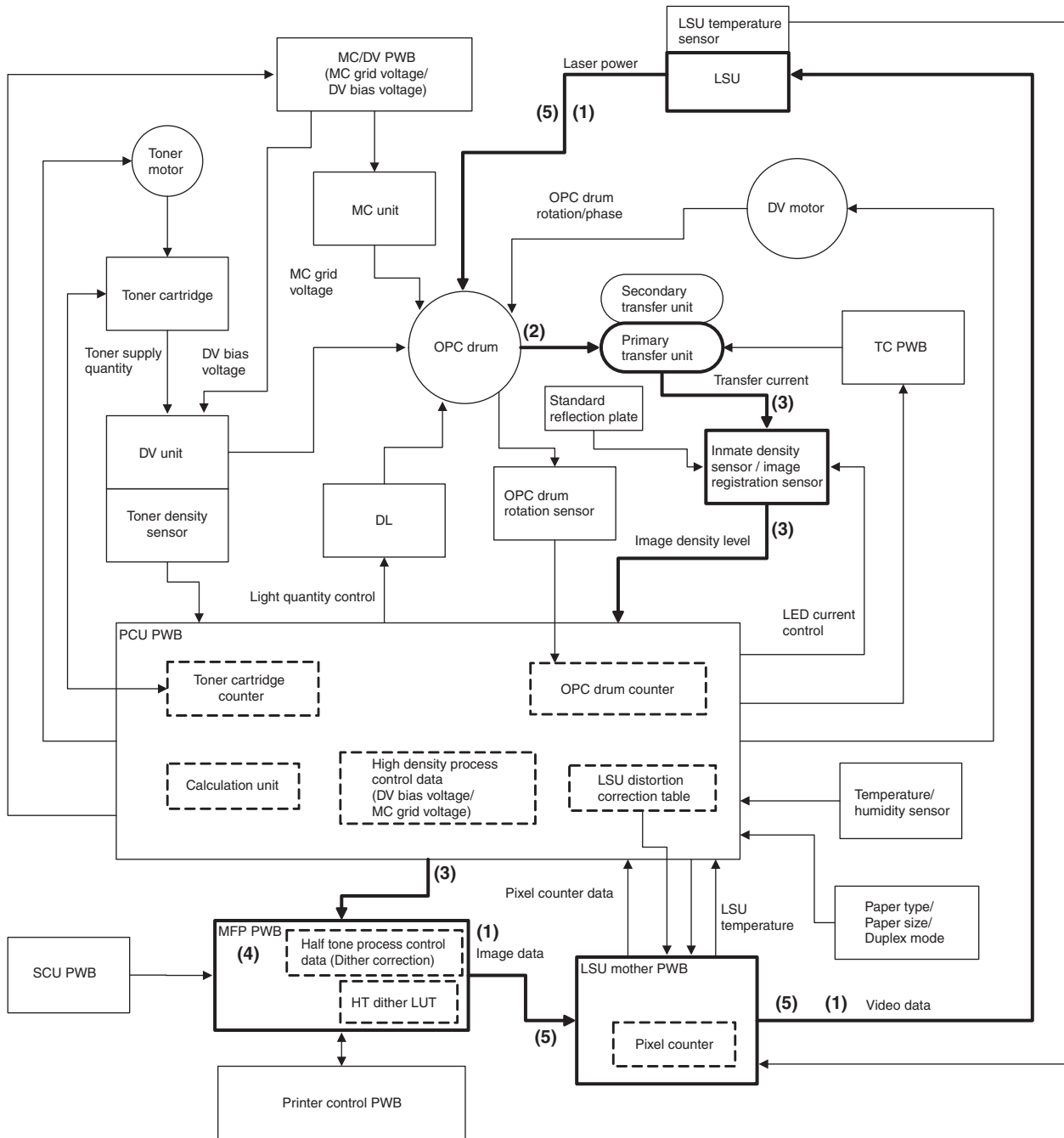

- (1) Toner patch electrostatic latent images are formed on the OPC drum.
- (2) The toner patch electrostatic latent images are developed and transferred on the primary transfer belt.
- (3) Each toner patch density is detected by the toner density sensor.
- (4) By comparing with the reference gamma, the correction value is calculated.
- (5) The dither data in the actual operation mode are formed in the MFP PWB according to the correction value, and applied to the actual operation mode.

#### d. Toner density correction / Toner density control

Different from the conventional models, this machine does not control the toner density in the developing unit according to the toner density detected by the toner density sensor.

The toner supply operation from the toner cartridge to the developing unit is controlled according to the following data so that the optimum developing is performed.

- The print pixel number for every page is counted and the toner consumption is calculated by the LSU mother PWB.
- The toner density is checked to be proper or not according to the result of the high density process control.
- The remaining toner quantity is presumed with the toner cartridge counter, and the toner supply quantity to the developing unit for the number of rotations of the toner motor is corrected. (This is because the toner supply quantity to the developing unit for the number of rotation of the toner motor differs depending on the remaining toner quantity in the toner cartridge.)
- Correction for the temperature and the humidity

The toner density sensor in this machine performs the following functions.

- Judges whether toner is supplied from the toner cartridge to the developing unit or not during rotation of the toner motor.
- Judges whether the toner density is abnormal or not.

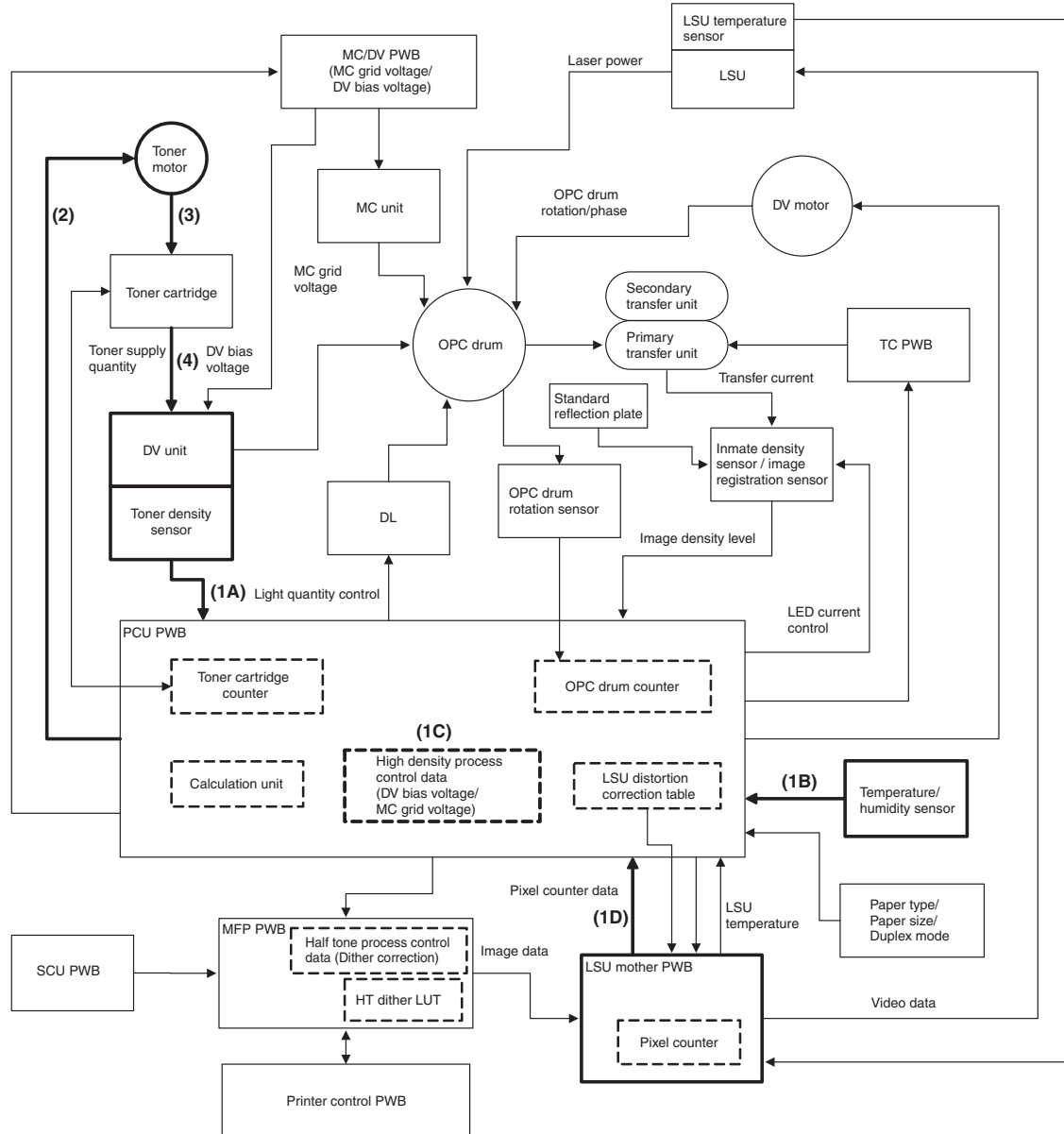

(1) The basic information of the toner density control is acquired.

- Temperature and humidity
- Print pixel number for every page
- High density process control data
- Toner cartridge counter
- Toner density sensor data

(2) The necessary toner supply quantity (toner motor rotation number) is calculated according to the basic information of the toner density control. (PCU PWB)

(3) The toner motor is rotated for the time corresponding to the calculated toner motor rotation number.

(4) Toner is supplied from the toner cartridge to the developing unit.

**(5) Setting of process control execution conditions**

**a. General**

The SIM44-62 function facilitates changing the process control execution conditions.

The SIM44-62 function also allows collective change of the set contents of SIM44-4 and SIM44-28 easily.

This is used to assure stable image qualities by executing proper operations of the process control according to the machine use status.

**b. SIM44-62 function and use**

- 1) Changes the image density in the high density area.
- 2) Changes the execution frequency of the process control.

**c. Setting method**

- 1) Enter the SIM44-62 mode, and select the set item.  
 To change the image density in the high density area, select PROCON TARGET.  
 To change the frequency of the process control operations, select PROCON MODE.

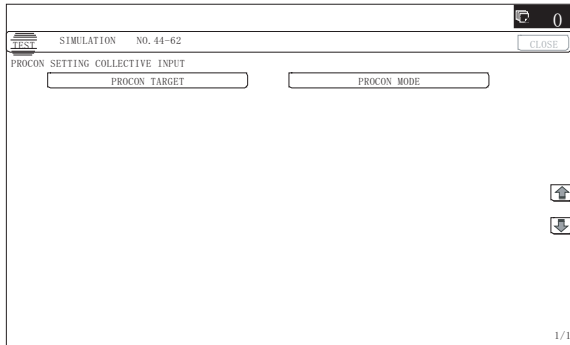

(When PROCON TARGET is selected.)

**2A) Select the density level.**

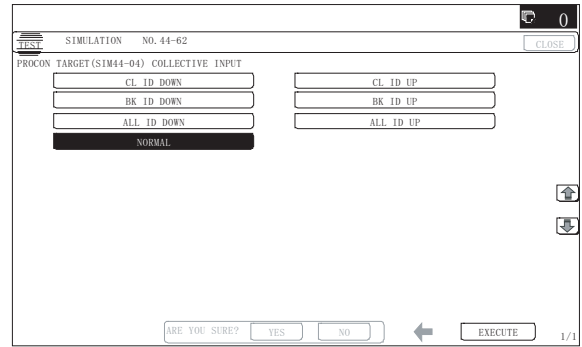

(Relation between the selected density level and the output image density)

CL ID DOWN	The densities of C, M, and Y decrease. (The C/M/Y high density process control target values decrease.)
CL ID UP	The densities of C, M, and Y increase. (The C/M/Y high density process control target values increase.)
BK ID DOWN	The density of K decreases. (The high density process control target value decreases.)
BK ID UP	The density of K increases. (The high density process control target value increases.)
ALL ID DOWN	The densities of C, M, Y and K decrease. (The C/M/Y/K high density process control target values decrease.)
ALL ID UP	The densities of C, M, Y and K increase. (The C/M/Y/K high density process control target values increase.)
NORMAL	The standard density of C, M, Y and K. (The C/M/Y/K high density process control target values are the standard values.)

(Relation between the selected density level and the SIM44-4 set values)

		SIM44-62 PROCON TARGET (Selected density level)							SIM44-4 set value
		Low			Normal	High			
Item (SIM44-4)		CL ID Down	BK ID Down	ALL ID Down	Normal (Default)	CL ID Up	BK ID Up	ALL ID Up	
A	PCS_CL TARGET	98	98	98	98	98	98	98	
B	PCS_K TARGET	208	208	208	208	208	208	208	
C	LED_CL OUTPUT	21	21	21	21	21	21	21	
D	LED_K OUTPUT	21	21	21	21	21	21	21	
E	PCS ADJUSTMENT LIMIT	4	4	4	4	4	4	4	
F	BELT GROUND DIF	1	1	1	1	1	1	1	
G	BIAS_CL STANDARD DIF	60	60	60	60	60	60	60	
H	BIAS_BK STANDARD DIF	0	0	0	0	0	0	0	
I	BIAS_PATCH INTERVAL	60	60	60	60	60	60	60	
J	Y_PAT TARGET ID	101	111	101	111	126	111	126	
K	M_PAT TARGET ID	125	135	125	135	150	135	150	
L	C_PAT TARGET ID	118	128	118	128	143	128	143	
M	K_PAT TARGET ID	45	40	40	45	45	55	55	
N	HV BK_GROUND LIMIT	60	60	60	60	60	60	60	

- 3A) Press [EXECUTE] key.
- 4A) Press [YES] key.  
 The SIM44-4 set value varies according to the selected density level.
- 5A) Execute SIM46-74 to adjust the copy and printer color balance.

(When PROCON MODE is selected.)

2B) Select the execution frequency level of the process control.

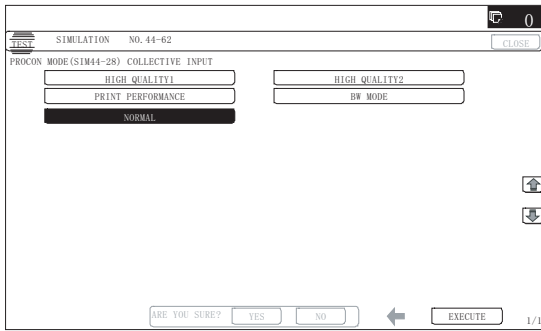

(Setting level and application)

HighQuality2:

The execution frequency of the process control is highest.  
 It is set when the color image quality is given priority.  
 Every time the power is turned ON, the process control is executed.  
 The execution frequency of the process control is about 3 times greater than the normal setting.  
 For a user who's main jobs are color jobs of more than 100 sheets/day with priority on the color image quality.

HighQuality1:

The execution frequency of the process control is high.  
 It is set when the color image quality is given priority.  
 Every time the power is turned ON, the process control is executed.  
 For a user of about 100 sheets/day with priority on the color image quality.

Normal (Default):

The process control is executed in the normal frequency.

BW Mode:

The process control is executed in the normal frequency.  
 It is set when there are little color jobs and many monochrome jobs.

The black process control is executed.

The color process control is occasionally executed according to the color toner consumption.

The color toner consumption is suppressed.

Print Performance:

The execution frequency of the process control is low.

It is set when the job speed is given priority.

The process control is executed in about 50% of the normal frequency during jobs.

For jobs of 100 or less, the process control is executed after completion of the jobs.

(Relation between the selected mode and the SIM44-28 set values)

		SIM44-62 and PROCON MODE (process control execution frequency level)					SIM44-28 set value
		Highest	High	Normal		Low	
Item (SIM44-28)		HighQuality2	HighQuality1	Normal (Default)	BW Mode	Print Performance	
A	INITIAL	0	0	0	0	0	
B	SW ON	0	0	3	3	3	
C	TIME	0	0	3	3	3	
D	HUM_LIMIT	0	0	0	2	0	
E	HUM	0	0	0	2	0	
F	REV1	0	0	0	1	1	
G	REV2_BK	0	0	0	0	0	
H	REV2_CL	0	0	0	0	0	
I	REFRESH MODE	1	1	1	1	1	
J	DAY	1	1	1	0	1	
K	HI-COV	0	0	0	0	1	
L	LO-COV	0	0	0	0	1	
M	TonerCA-END	1	1	1	1	1	
O	AVERAGE-PAGE	3	3	3	3	3	
P	LIMIT PAGE	5	5	10	10	10	
Q	PIX_RATIO_BK	10	10	10	10	10	
R	PIX_RATIO_CL	10	10	10	50	10	
S	INTERVAL TIME	3	3	3	3	3	
T	HUM HOUR	2	2	2	2	2	
U	HUM_DIF	2	2	2	2	4	
V	BK_RATIO	5	10	15	30	30	
W	M_RATIO	5	10	15	30	30	
X	COLOR BORDER	20	20	20	100	20	
Y	BK ONLY	5	5	5	6	5	
Z	HT_DIF	1	20	40	40	40	
AA	RG_ON_SYNC	0	0	0	0	0	
AB	RG_TEMP_TIMER	0	0	0	0	0	
AC	RG_PERM_TIMER	0	1	1	1	1	
AC	RG_HOUR_TIMER	3	5	5	11	11	
AD	RG_BW_SYNC	1	1	1	1	1	

Items out of application: 2TRAN\_CLEAN\_TIME1/2TRAN\_CLEAN\_TIME2/2TRAN\_CLEAN\_TIME3

3B) Press [EXECUTE] key.

4B) Press [YES] key.

The SIM44-28 set value varies according to the selected execution frequency level of the process control.

**Note**

This simulation may not function with some firmware versions. In such a case, the firmware must be upgraded to the latest version



## E. Other correction items and contents

The table below shows the correction item, the change item, the purpose/effect, and the operation timing for the other correction items.

Item No.	Correction item	Change item	Purpose/Effect	Operation timing/ Operation condition	
1	OPC drum deterioration correction	Main charger grid voltage correction	Main charger grid voltage 1	The surface dark potential fall due to the OPC drum OPC layer membrane decrease and electric and optical stress is corrected to maintain the proper density for print and prevent overlap copy.	When executing the high density process control.
			Main charger grid voltage 2	The surface dark potential fall due to the temperature and the humidity is corrected to maintain the proper density for print and prevent overlap copy.	
		Discharge lamp light quantity correction	Discharge lamp light quantity (ON DUTY 1)	A change (an increase in the surface dark potential) in a change in the OPC drum sensitivity (a change in the discharge efficiency) due to the OPC drum OPC layer membrane decrease and electrical and optical stress is corrected to maintain the proper density for print.	
			Discharge lamp light quantity (ON DUTY 2)	A change in the OPC drum sensitivity (a change in the discharge efficiency) (a change in the surface dark potential) due to the temperature and the humidity is corrected to maintain the proper density for print.	
		Laser power correction	Laser power 1	A fall in the OPC drum photo sensitivity due to the OPC drum OPC layer membrane decrease and electrical and optical stress is corrected to maintain the proper density for print.	

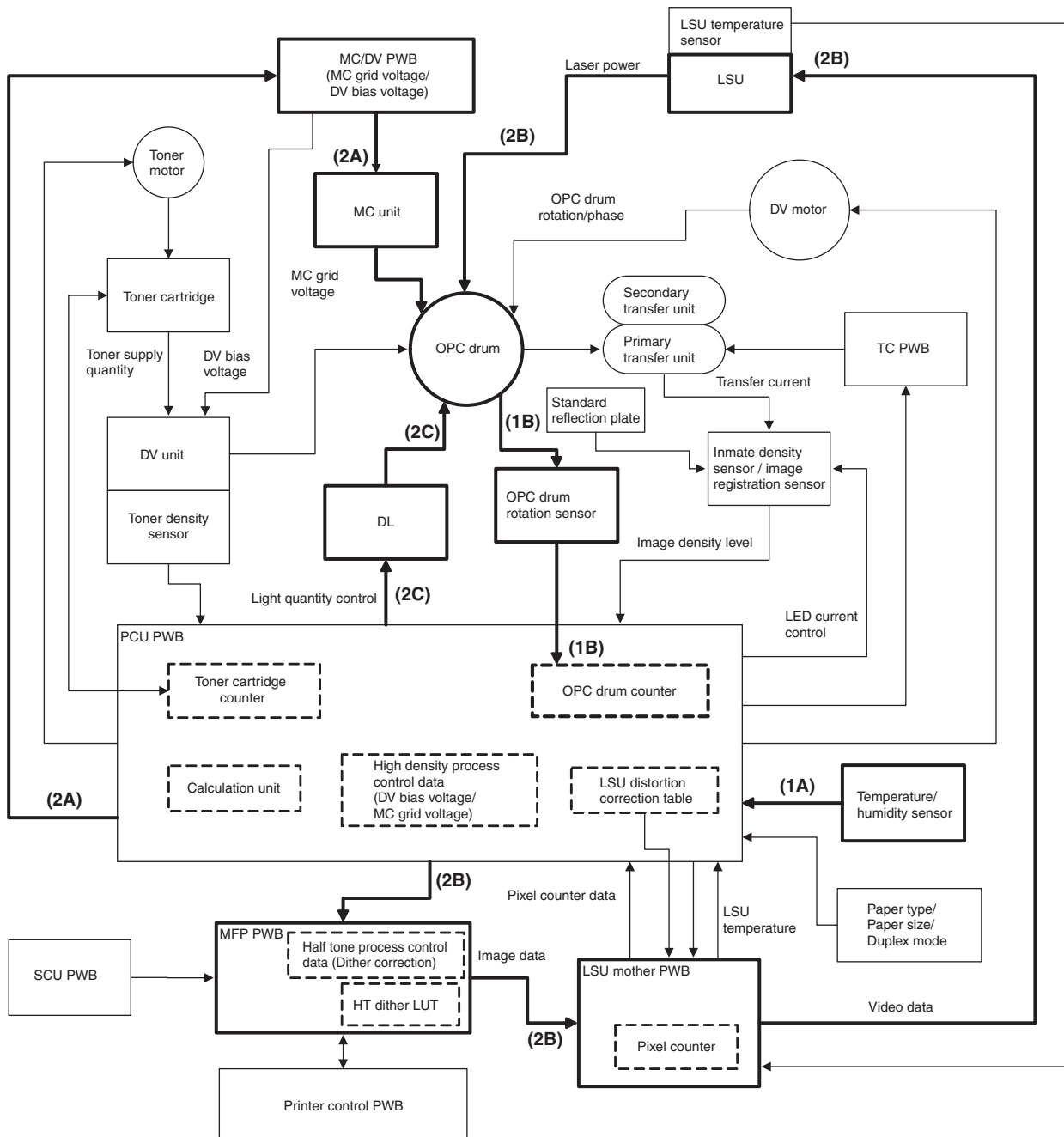

Item No.	Correction item		Change item	Purpose/Effect	Operation timing/ Operation condition
2	Transfer capability correction (Primary transfer)	Correction of the transfer current for the environment (A change in the temperature and the humidity)	Primary transfer current 1	A change in the transfer characteristics (transfer efficiency) due to a change in the temperature and the humidity is corrected by changing the transfer current.	A change in the environmental area (temperature and humidity) / Before the high density process control operation (AND condition)
		Correction of the transfer current for the high density process control (MC grid voltage)	Primary transfer current 2	A change in the transfer characteristics (transfer efficiency / memory) according to the surface potential of the OPC drum is corrected by changing the transfer current value.	After the OPC drum surface potential is changed by the high density process control

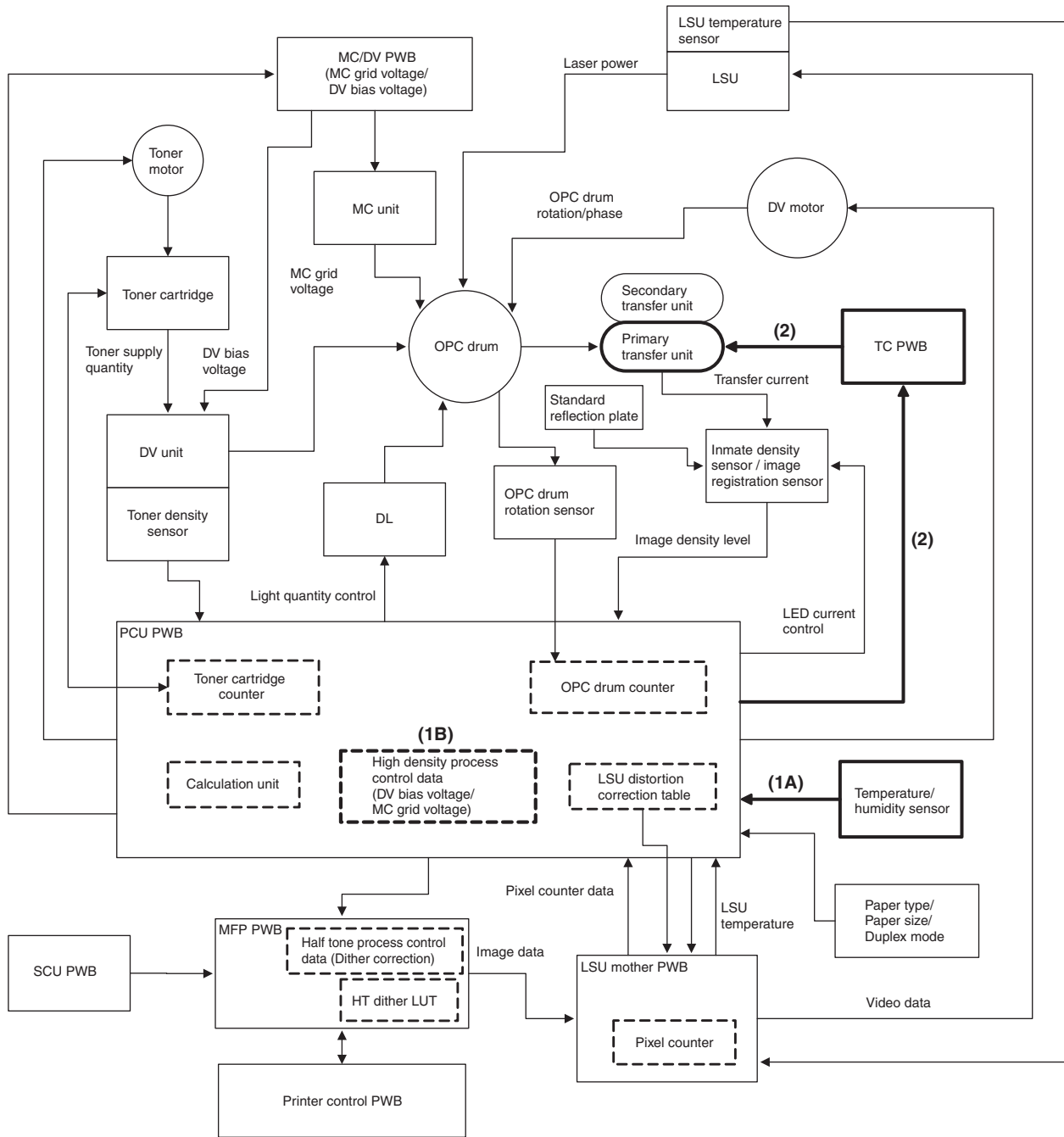

Item No.	Correction item		Change item	Purpose/Effect	Operation timing/ Operation condition
3	Transfer capability correction (Secondary transfer)	Correction of the transfer current for the environment (A change in the temperature and the humidity)	Secondary transfer current 1	A change in the transfer characteristics for a change in the paper state due to a change in the temperature and the humidity is corrected by changing the transfer current.	Environmental area (temperature and humidity) change
		Transfer current correction for back surface print	Secondary transfer current 2	A change in the transfer efficiency for a change in the paper state is corrected to maintain the proper density for print.	When printing the back surface
		Correction of the transfer current for the paper kind (thickness and material) for transfer and the size	Secondary transfer current 3	A difference in the flow of the transfer current due to the paper kind and size is corrected.	For every change in the paper kind or size

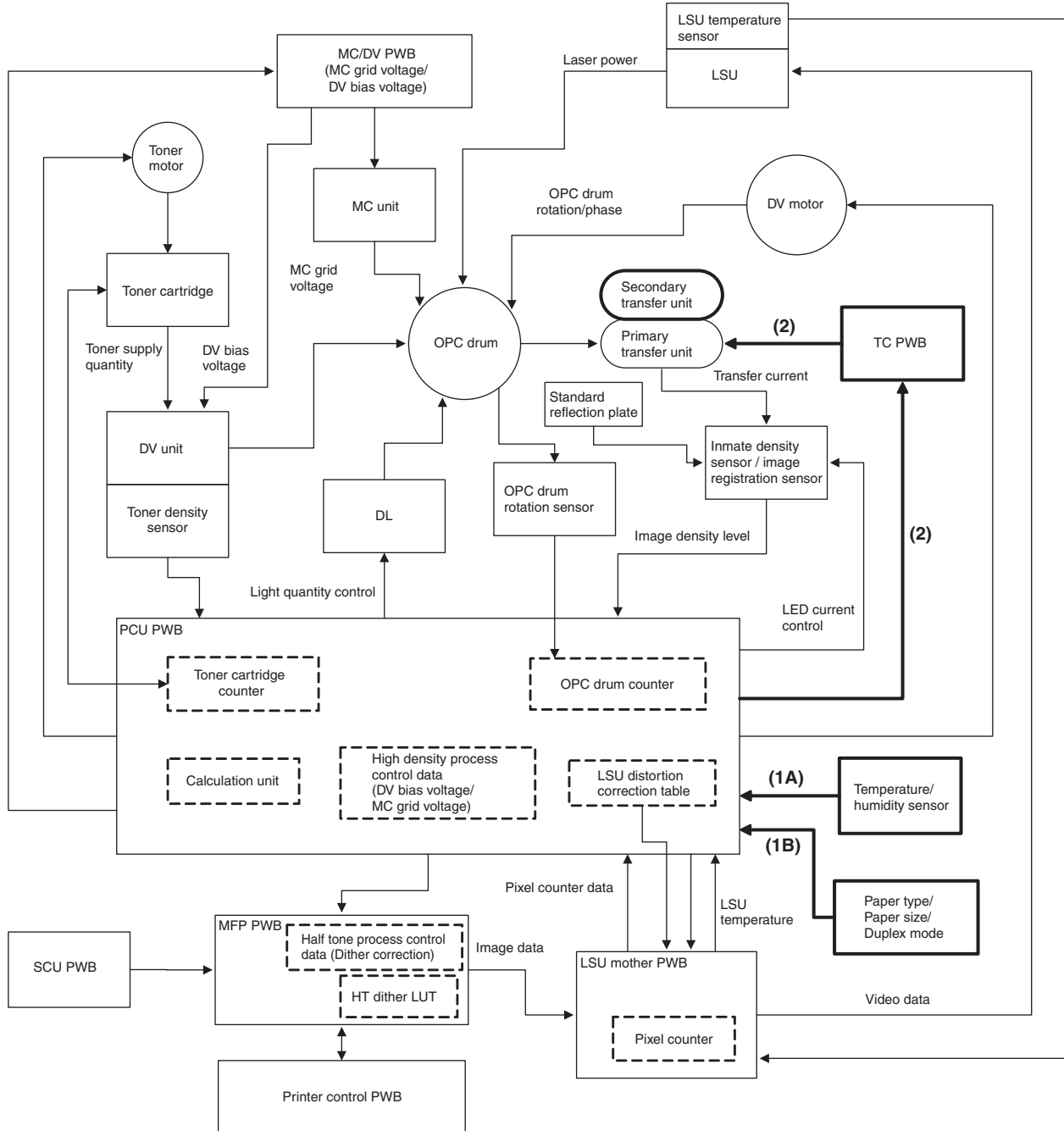

ItemNo.	Correction item	Change item	Purpose/Effect	Operation timing/Operation condition
4	Automatic image registration adjustment	LSU exposure timing	An image registration generated by a variation in the LSU unit, a position shift and rotations of the transfer belt is automatically adjusted.	After execution of SIM50-22 / User image registration adjustment / After high density process control operation

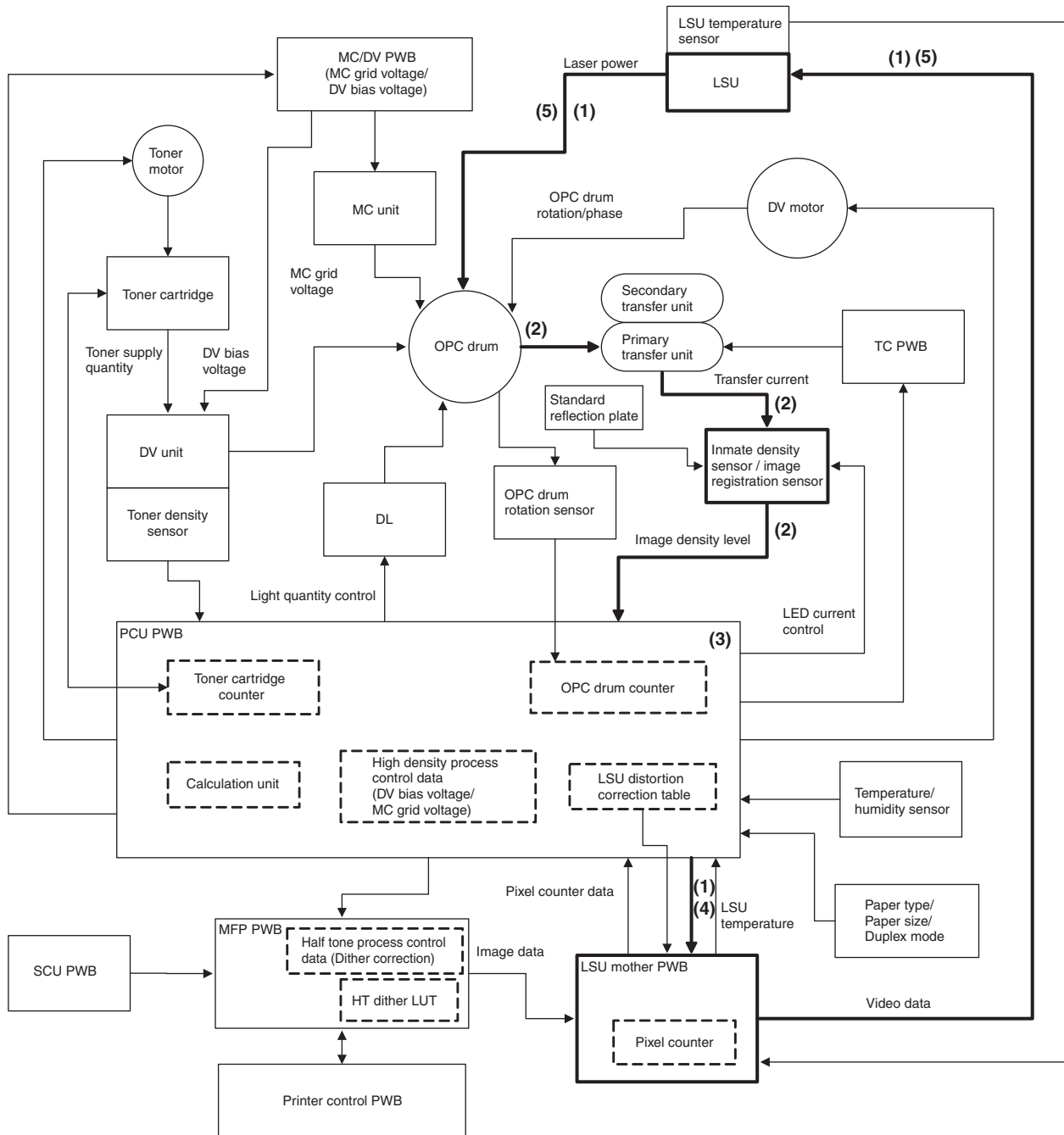

ItemNo.	Correction item	Change item	Purpose/Effect	Operation timing/Operation condition
5	LSU heat distortion correction	LSU exposure timing	An image registration and distortion generated by the optical axis shift due to the LSU heat distortion are automatically corrected.	Laser ON timing

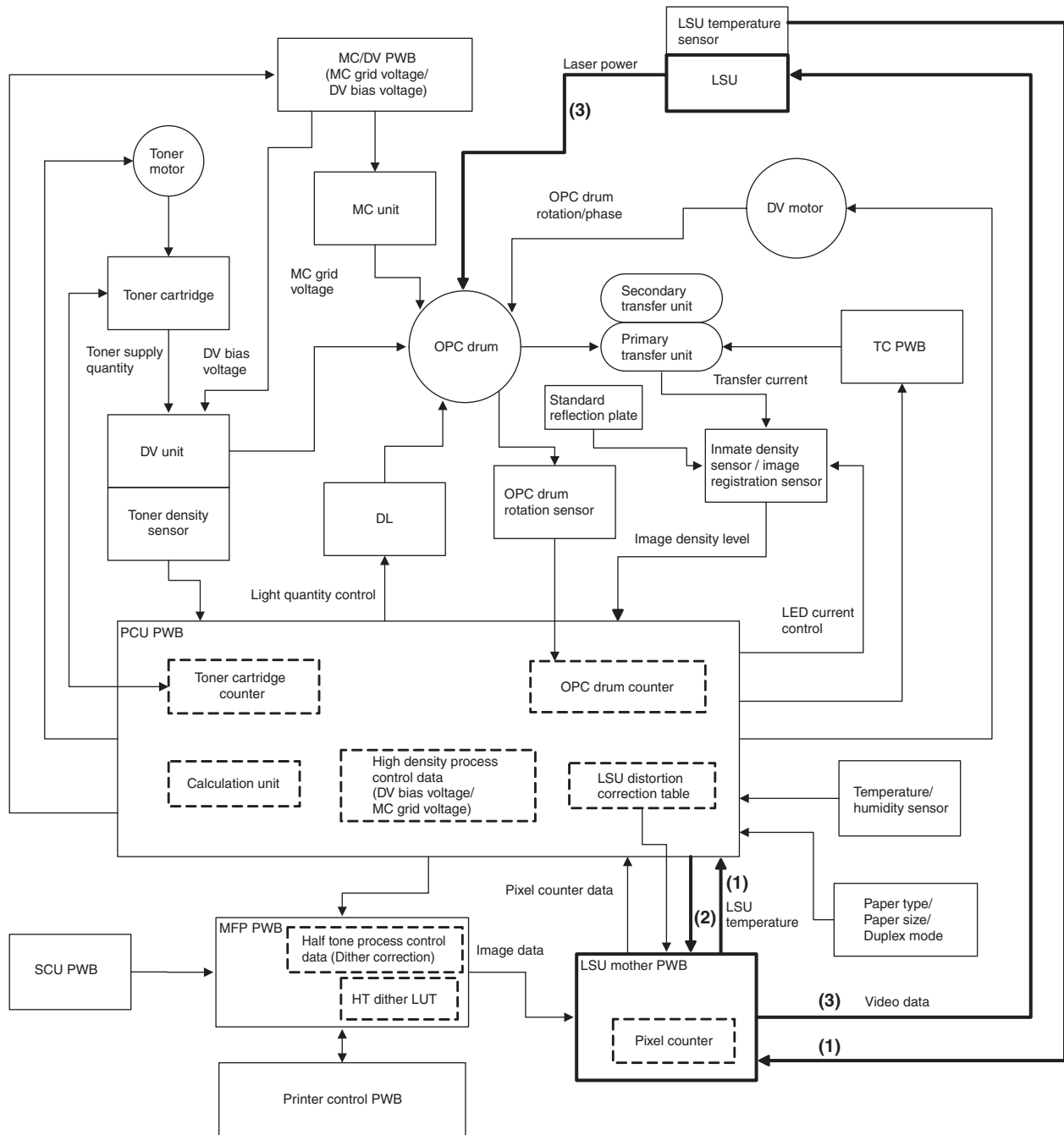

## F. OPC drum section

### (1) Electrical and mechanism relation diagram

#### a. 18cpm/20cpm/23cpm/26cpm/31cpm machine

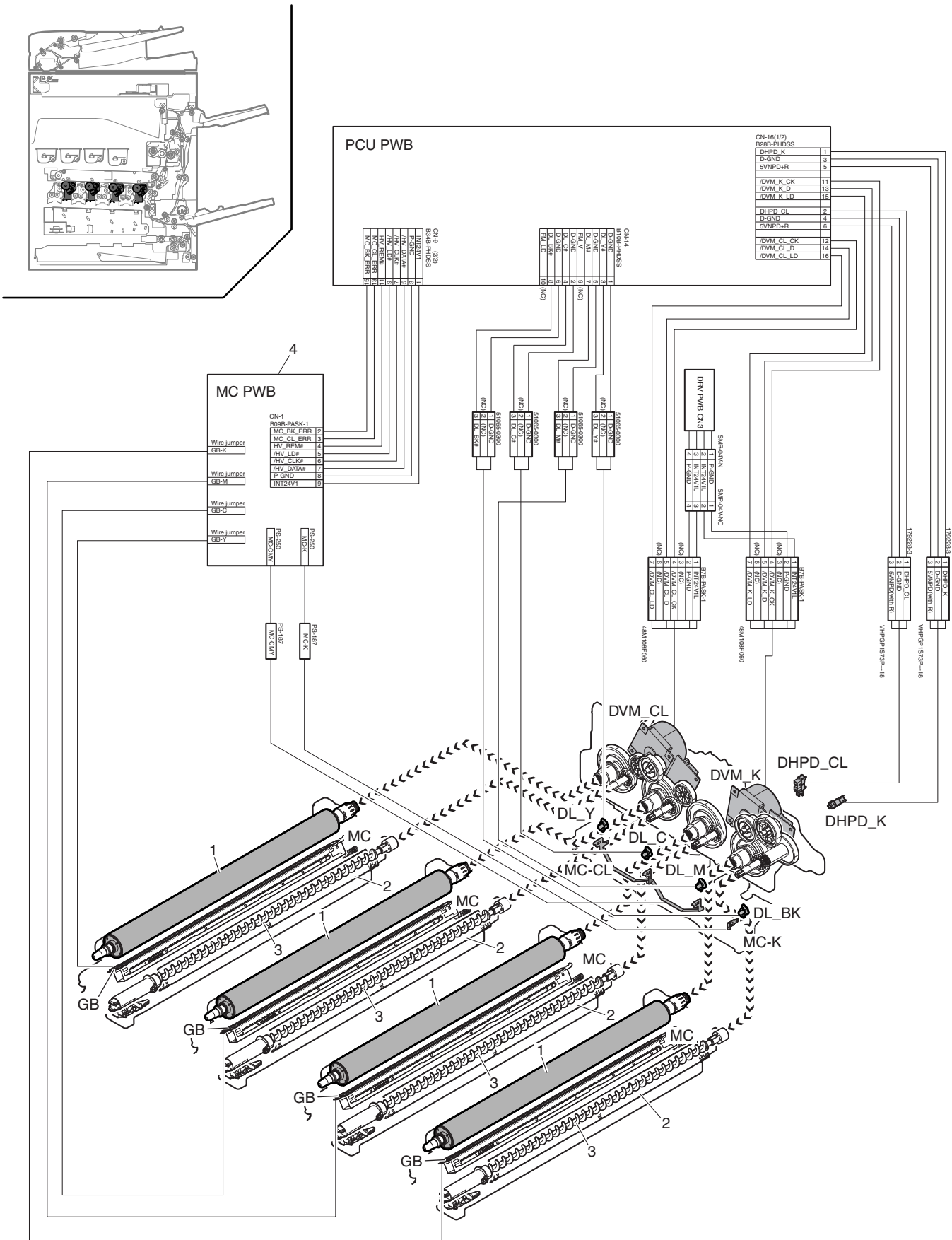

Signal name	Name	Function/Operation
DHPD_CL	OPC drum rotation sensor (CL)	Detects rotation and the phase of the OPC drum (CL).
DHPD_K	OPC drum rotation sensor (BK)	Detects rotation and the phase of the OPC drum (BK).
DL_BK	Discharge lamp (K)	Discharges electric charges on the OPC drum (K).
DL_C	Discharge lamp (C)	Discharges electric charges on the OPC drum (C).
DL_M	Discharge lamp (M)	Discharges electric charges on the OPC drum (M).
DL_Y	Discharge lamp (Y)	Discharges electric charges on the OPC drum (Y).
DVM_CL	Developing motor (CL)	Drives the developing/OPC drum section (CL).
DVM_K	Developing motor (K)	Drives the developing/black OPC drum (BK)/transfer section.
GB (Y, M, C, K)	Grid (Y, M, C, K)	The OPC drum surface potential is controlled.
GB (K, M, C, Y)	Main charger grid voltage (K, M, C, Y)	The OPC drum surface charging voltage is controlled.
MC (Y, M, C, K)	Main charger (Y, M, C, K)	The OPC drum surface is negatively charged.
MC-CL	Main charger applying voltage (CL)	The main charger is charged to generate negative electric charges.
MC-K	Main charger applying voltage (K)	

No.	Name	Function/Operation
1	OPC drum unit (Y, M, C, K)	Latent electrostatic images are formed.
2	Cleaning blade (Y, M, C, K)	Remaining toner on the OPC drum surface is cleaned.
3	Waste toner transport screw	Waste toner in the OPC drum unit is transported to the waste toner collection section.
4	High voltage PWB (MC/DV PWB)	Generates the main charger voltage and the DV bias voltage.

b. 36cpm machine

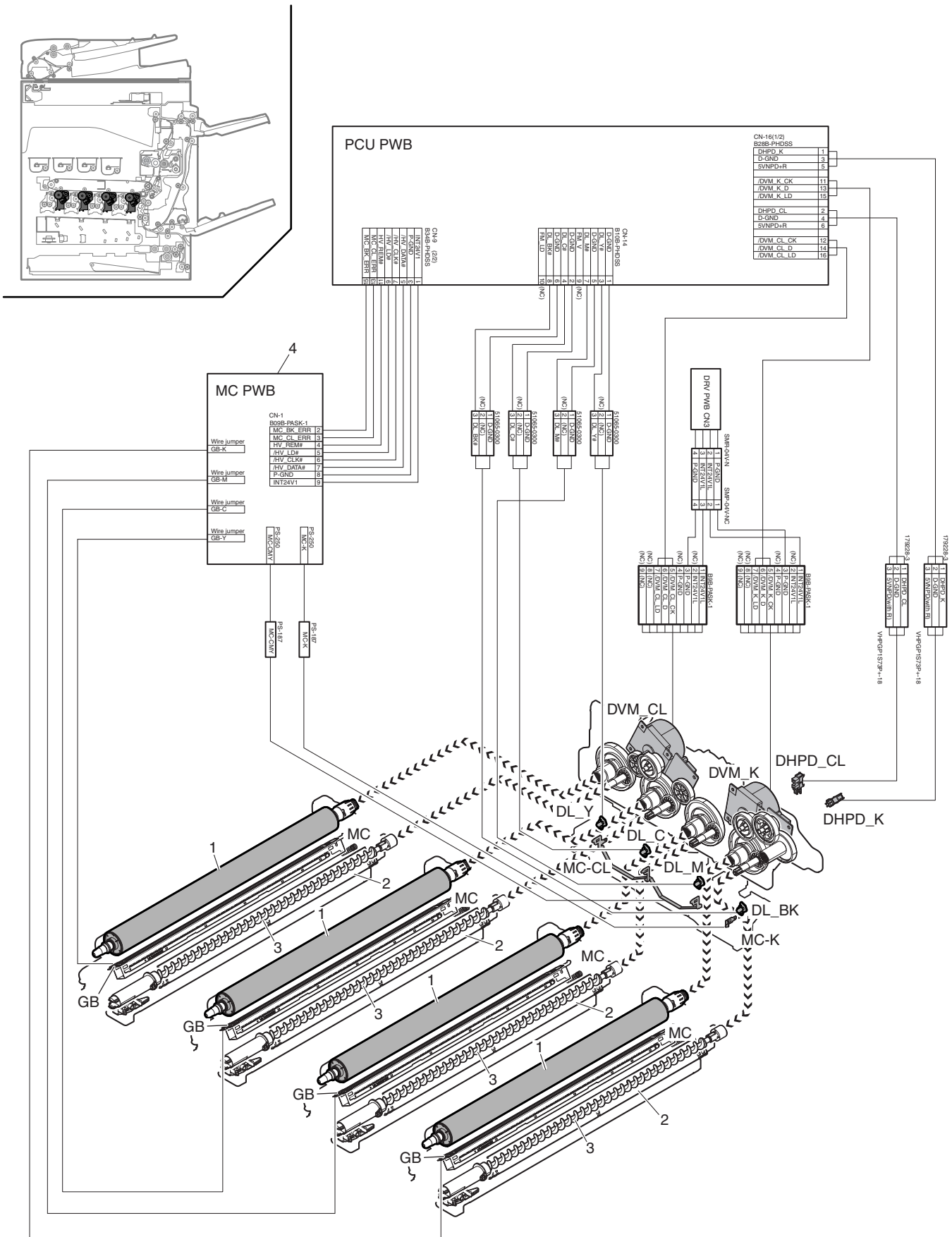



Signal name	Name	Function/Operation
DHPD_CL	OPC drum rotation sensor (CL)	Detects rotation and the phase of the OPC drum (CL).
DHPD_K	OPC drum rotation sensor (BK)	Detects rotation and the phase of the OPC drum (BK).
DL_BK	Discharge lamp (K)	Discharges electric charges on the OPC drum (K).
DL_C	Discharge lamp (C)	Discharges electric charges on the OPC drum (C).
DL_M	Discharge lamp (M)	Discharges electric charges on the OPC drum (M).
DL_Y	Discharge lamp (Y)	Discharges electric charges on the OPC drum (Y).
DVM_CL	Developing motor (CL)	Drives the developing/OPC drum section (CL).
DVM_K	Developing motor (K)	Drives the developing/black OPC drum (BK)/transfer section.
GB (Y, M, C, K)	Grid (Y, M, C, K)	The OPC drum surface potential is controlled.
GB (K, M, C, Y)	Main charger grid voltage (K, M, C, Y)	The OPC drum surface charging voltage is controlled.
MC (Y, M, C, K)	Main charger (Y, M, C, K)	The OPC drum surface is negatively charged.
MC-CL	Main charger applying voltage (CL)	The main charger is charged to generate negative electric charges.
MC-K	Main charger applying voltage (K)	

No.	Name	Function/Operation
1	OPC drum unit (Y, M, C, K)	Latent electrostatic images are formed.
2	Cleaning blade (Y, M, C, K)	Remaining toner on the OPC drum surface is cleaned.
3	Waste toner transport screw	Waste toner in the OPC drum unit is transported to the waste toner collection section.
4	High voltage PWB (MC/DV PWB)	Generates the main charger voltage and the DV bias voltage.

## (2) Operational descriptions

The OPC drum surface is negatively charged by the main charger, then laser image beams are radiated to the OPC drum surface by the laser (writing) unit to form electrostatic latent images.

- 1) The OPC drum surface is negatively charged by the main charger.

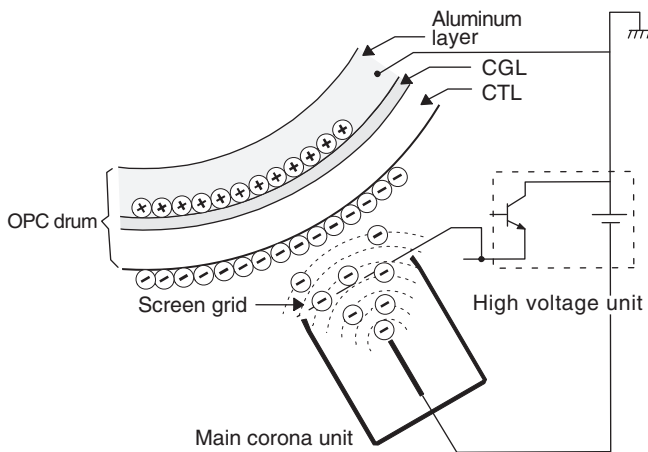

The main charger grid is provided with the screen grid. The OPC drum is charged at a voltage virtually same as the voltage applied to the screen grid.

- 2) Laser beams are radiated to the OPC drum surface by the laser (writing) unit to form electrostatic latent images.

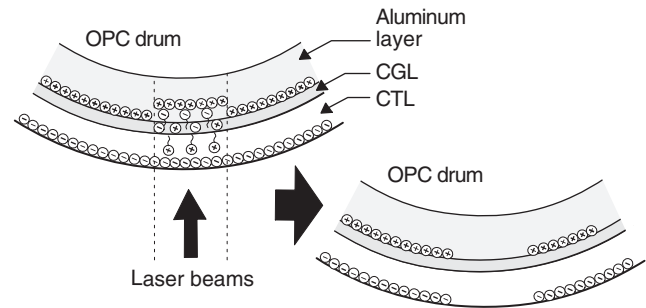

When laser beams are radiated onto the CGL of the OPC drum, positive and negative charges are generated.

Positive charges generated in CGL are attracted to the negative charges on the OPC drum surface. On the other hand, negative charges are attracted to positive charges in the aluminum layer of the OPC drum.

Therefore, positive charges and negative charges are balanced out on the OPC drum and in the aluminum layer, reducing positive and negative charges to decrease the OPC drum surface voltage.

Electric charges remain at a position where laser beam are not radiated.

As a result, latent electrostatic images are formed on the OPC drum surface.

- 3) After transfer operation, remaining toner is removed by the cleaning blade.

Toner removed from the OPC drum surface is transported to the waste toner section by the waste toner transport screw.

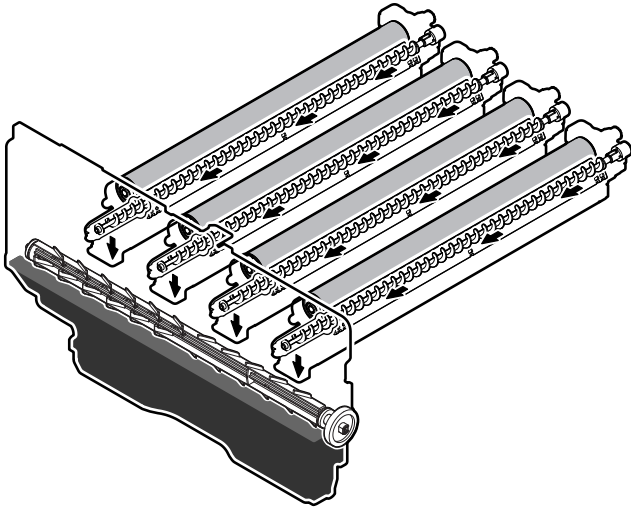

**OPC drum rotation control**

The OPC drum (K) is driven by the DV motor (DVM\_K), and the rotation speed is monitored by the OPC drum rotation sensor (DHPD\_K).

The color OPC drums (C, M, and Y) are driven by the DV motor (DVM\_CL), and the rotation speed is monitored by the OPC drum rotation sensor (DHPD\_CL).

Based on the signals monitored by the two sensors, the rotation speeds of K OPC drum and the color OPC drums and the rotation phase are controlled.

- 4) The whole surface of the OPC drum is discharged.

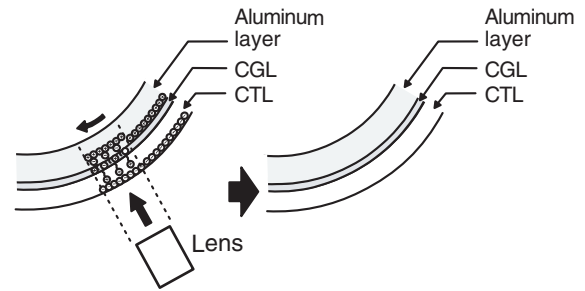

By radiating the discharge lamp light to the discharge lens, light is radiated through the lens to the OPC drum surface.

When the discharge lamp light is radiated to the OPC drum CGL, positive and negative charges are generated.

Positive charges generated in CGL are attracted to the negative charges on the OPC drum surface. On the other hand, negative charges are attracted to positive charges in the aluminum layer of the OPC drum.

Therefore, positive and negative charges are balanced out on the OPC drum surface and in the aluminum layer, reducing positive and negative charged to decrease the surface voltage of the OPC drum.

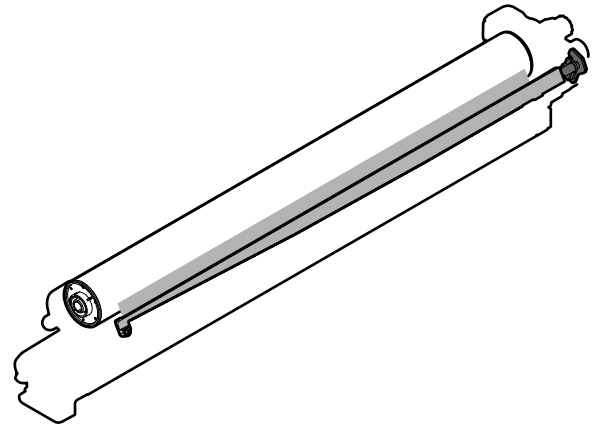

## G. Toner supply section

### (1) Electrical and mechanism relation diagram

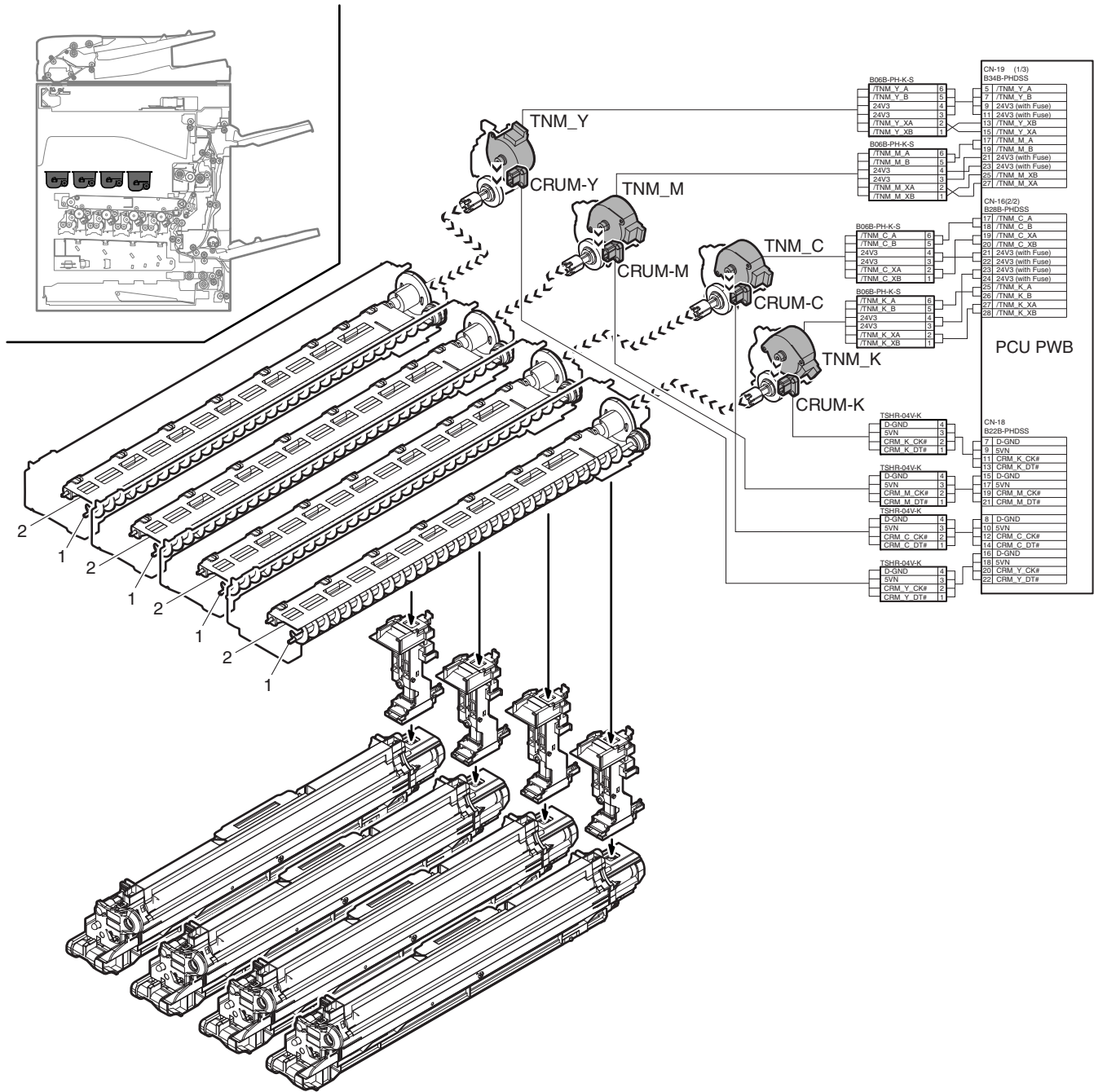

Signal name	Name	Function/Operation
CRUM	CRUM (Y, M, C, K)	Saves various data of the toner cartridge.
TNM_C	Toner motor (C)	Supplies toner from the toner cartridge (C) to the developing unit.
TNM_K	Toner motor (K)	Supplies toner from the toner cartridge (K) to the developing unit.
TNM_M	Toner motor (M)	Supplies toner from the toner cartridge (M) to the developing unit.
TNM_Y	Toner motor (Y)	Supplies toner from the toner cartridge (Y) to the developing unit.

No.	Name	Function/Operation
1	Toner transport screw	Transports toner from the toner cartridge to the developing unit.
2	Toner stirring plate	Moves the toner stirring plate and toner to the toner transport screw to assist the toner transport operation.

### (2) Operational descriptions

Based on the print pixel count and the process control information, Yes/No of toner supply is judged.

When it is judged that the toner density is decreasing, the toner motor is rotated to supply toner in the toner cartridge through the toner transport screw and the toner duct to the developing unit.



<b>Signal name</b>	<b>Name</b>	<b>Function/Operation</b>
1TURC_1	Primary transfer separation clutch 1	Controls separation of the primary transfer unit.
BS (K, M, C, Y)	Developing bias voltage (K, M, C, Y)	Voltage to form toner images on the OPC drum. Controls the developing density.
DVM_CL	Developing motor (CL)	Drives the developing/OPC drum section (CL).
DVM_K	Developing motor (K)	Drives the developing/black OPC drum (BK)/transfer section.
TCS_C	Toner sensor (C)	Detects toner supply from the toner cartridge. Detects the toner density (C).
TCS_K	Toner sensor (K)	Detects toner supply from the toner cartridge. Detects the toner density (K).
TCS_M	Toner sensor (M)	Detects toner supply from the toner cartridge. Detects the toner density (M).
TCS_Y	Toner sensor (Y)	Detects toner supply from the toner cartridge. Detects the toner density (Y).

<b>No.</b>	<b>Name</b>	<b>Function/Operation</b>
1	Developing roller	Attaches toner to electrostatic latent images on the OPC drum and forms toner images.
2	Stirring roller	Stirs developer and toner to negatively charge toner.
3	Doctor	Maintains the quantities of toner and developer on the DV roller at a constant levels.
4	Toner filter (K, M, C, Y)	Prevents toner splash.
5	High voltage PWB (MC/DV PWB)	Generates the main charger voltage and the DV bias voltage.



Signal name	Name	Function/Operation
1TURC_1	Primary transfer separation clutch 1	Controls separation of the primary transfer unit.
BS (K, M, C, Y)	Developing bias voltage (K, M, C, Y)	Voltage to form toner images on the OPC drum. Controls the developing density.
DVM_CL	Developing motor (CL)	Drives the developing/OPC drum section (CL).
DVM_K	Developing motor (K)	Drives the developing/black OPC drum (BK)/transfer section.
TCS_C	Toner sensor (C)	Detects toner supply from the toner cartridge. Detects the toner density (C).
TCS_K	Toner sensor (K)	Detects toner supply from the toner cartridge. Detects the toner density (K).
TCS_M	Toner sensor (M)	Detects toner supply from the toner cartridge. Detects the toner density (M).
TCS_Y	Toner sensor (Y)	Detects toner supply from the toner cartridge. Detects the toner density (Y).

No.	Name	Function/Operation
1	Developing roller	Attaches toner to electrostatic latent images on the OPC drum and forms toner images.
2	Stirring roller	Stirs developer and toner to negatively charge toner.
3	Doctor	Maintains the quantities of toner and developer on the DV roller at a constant levels.
4	Toner filter (K, M, C, Y)	Prevents toner splash.
5	High voltage PWB (MC/DV PWB)	Generates the main charger voltage and the DV bias voltage.

## (2) Operational descriptions

Toner is attached to electrostatic latent images formed on the OPC drum surface by laser image beams to form toner images.

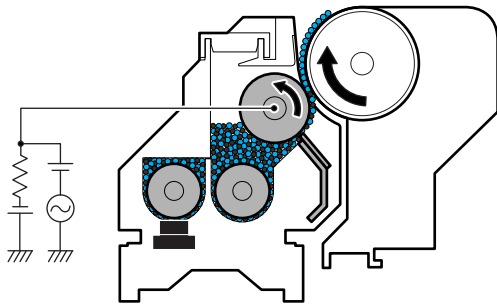

Toner and carrier in the developing unit are agitated and transported by the mixing roller.

By stirring, toner and carrier are negatively charged by mechanical friction.

The developing bias voltage (AC component and negative DC component) is applied to the developing roller.

Negatively charged toner is attracted to the exposed section on the OPC drum where the negative potential falls due to the developing bias.

If the OPC drum is not exposed, the negative potential is higher than the developing bias voltage, and toner is not attracted.

The toner sensor detects the toner supply state from the toner cartridge.

In this machine, the toner density is detected by the toner sensor, but the toner supply operation is not controlled only by the toner density detection result. The toner density control is performed according to the process control data.

# I. Transfer section

## (1) Electrical and mechanism relation diagram

### a. Transfer section

#### a-1. 18cpm/20cpm/23cpm/26cpm/31cpm machine

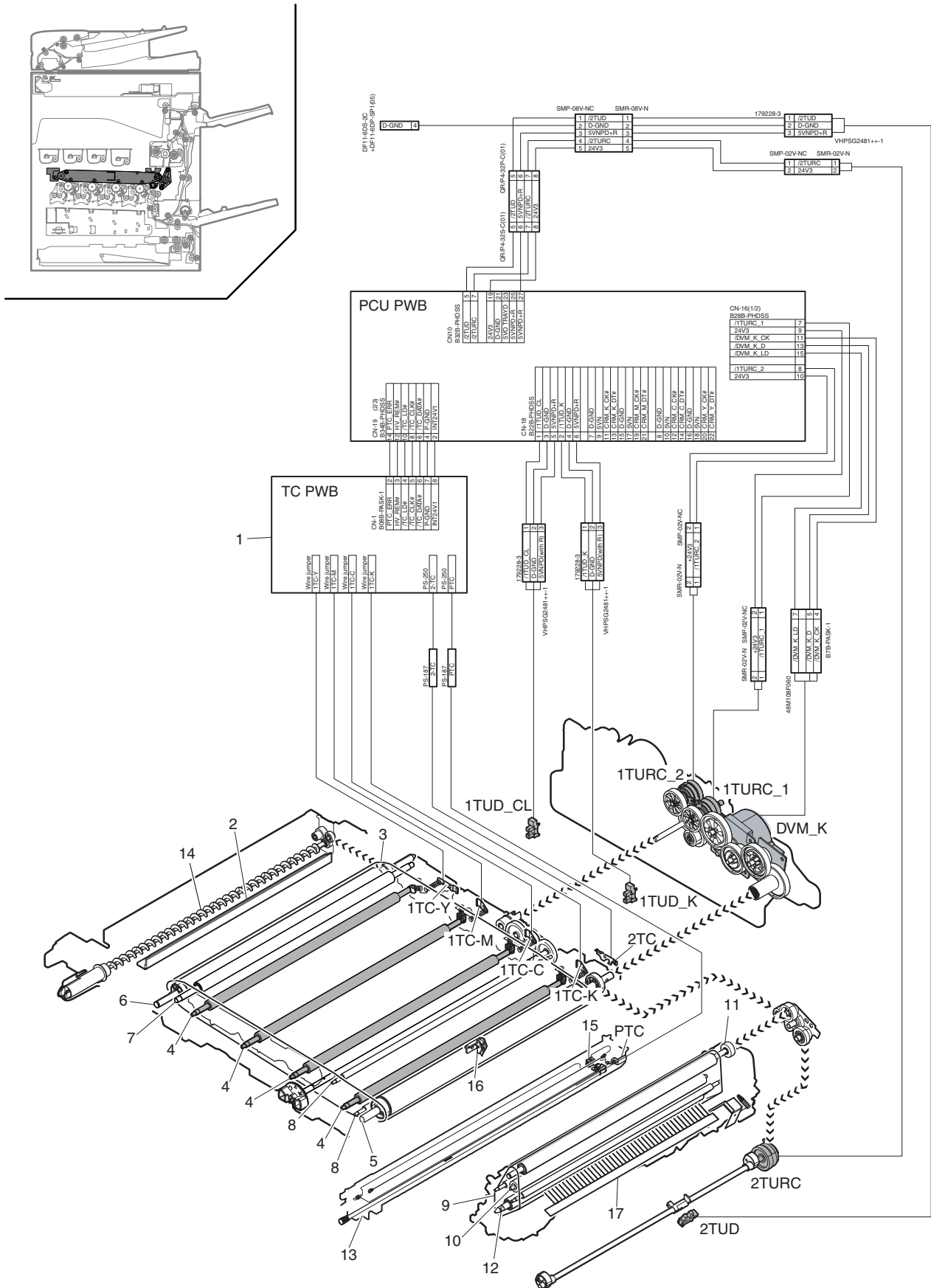



Signal name	Name	Function/Operation
1TC (CMY)	Primary transfer voltage (CMY)	Flows the transfer current to the primary transfer belt, and transfers toner images from the OPC drum to the transfer belt.
1TC (K)	Primary transfer voltage (K)	Flows the transfer current to the primary transfer belt, and transfers toner images from the OPC drum to the transfer belt.
1TUD_CL	Transfer mode detector (CL)	Detects separation of the transfer belt and the transfer mode. (Detection is made by combination of 1TUD_CL/1TUD_K signals.)
1TUD_K	Transfer mode detector (BK)	Detects separation of the transfer belt and the transfer mode. (Detection is made by combination of 1TUD_CL/1TUD_K signals.)
1TURC_1	Primary transfer separation clutch 1	Controls separation of the primary transfer unit.
1TURC_2	Primary transfer separation clutch 2	Controls separation of the primary transfer unit.
2TC	Secondary transfer belt voltage	Flows the transfer current to the secondary transfer belt, and transfers toner images from the primary transfer belt to paper.
2TUD	Secondary transfer position detector	Detects the position (separation) of the secondary transfer unit.
2TURC	Secondary transfer separation clutch	Controls separation of the secondary transfer unit.
DVM_K	Developing motor (K)	Drives the developing/black OPC drum (BK)/transfer section.
PTC	PTC voltage	High voltage for PTC

No.	Name	Function/Operation
1	High voltage PWB (TC PWB)	Generates the transfer voltage.
2	Cleaning blade	Cleans residual toner on the primary transfer belt.
3	Primary transfer belt	Transfers toner images of the OPC drum onto the transfer belt.
4	Primary transfer roller (K, C, M, Y)	Applies a high positive voltage to the primary transfer belt.
5	Primary transfer belt drive roller	Drives the transfer belt. A negative voltage is applied when in the transfer operation, and an alternate high voltage (positive and negative) is applied when cleaning.
6	Primary transfer belt follower roller	Transfer belt follower drive
7	Primary transfer belt tension roller	Applies a tension to the transfer belt.
8	PTC opposed roller	Flows the PTC current to the GND.
9	Secondary transfer belt	Transfers toner images on the primary transfer belt to paper.
10	Secondary transfer roller	Connects the secondary transfer belt to the GND, and flows the transfer current.
11	Secondary transfer belt drive roller	Drives the transfer belt.
12	Secondary transfer belt follower roller	Transfer belt follower drive
13	PTC unit	Reduces positive charges on the primary transfer belt, and improves the transfer efficiency.
14	Primary transfer waste toner transport screw	Transports waste toner in the primary transfer cleaning unit to the waste toner collection section.
15	PTC cleaner	Clean the PTC wire.
16	Separation pawl	Separates paper after transfer.
17	Discharge brush	Discharges the secondary transfer belt surface after transfer to neutralize it.

a-2. 36cpm machine

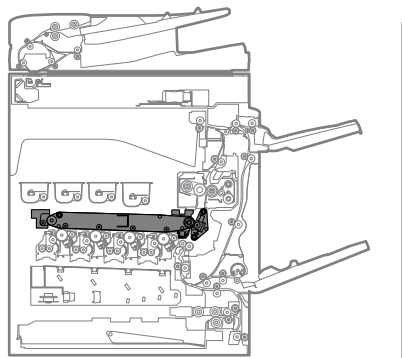

814B-PHDSS	
D-GND	14
SVNPDin	13
D-GND	12
SVNPD+R1	11
D-GND	10
SVNPD+R2	9
D-GND	8
SVN+R3	7
D-GND	6
SVN+R2	5
D-GND	4
SVN+R1	3
D-GND	2
SVNin	1

R-DOOR  
PWB

CN10 PHDSS	
Z1LURC	15
Z1LURC	14
Z4V3	13
D-GND	12
300TAWD	11
D-GND	10
SVNPD+R	9
D-GND	8

CN18 832B-PHDSS	
D-GND	1
D-GND	2
D-GND	3
D-GND	4
D-GND	5
D-GND	6
D-GND	7
D-GND	8
D-GND	9
D-GND	10
D-GND	11
D-GND	12
D-GND	13
D-GND	14
D-GND	15
D-GND	16
D-GND	17
D-GND	18
D-GND	19
D-GND	20
D-GND	21
D-GND	22
D-GND	23
D-GND	24
D-GND	25
D-GND	26
D-GND	27
D-GND	28
D-GND	29
D-GND	30
D-GND	31
D-GND	32

CN-12 832B-PHDSS	
/BTM_CLK	29
/BTM_D	31
/BTM_LD	30
/BTM_BFAAKE	32

CN-16(1/2) 828B-PHDSS	
/1TURC_1	7
24V3	9
/DVM_K CK	11
/DVM_K D	12
/DVM_K LD	15
/1TURC_2	8
24V3	10

CN-19 (2/3) 814B-PHDSS	
HV+BEAM	1
HV-LEAD	2
/TTC_LD	3
/TTC_DATA	4
/TTC_DATA	5
F-GND	6
D-GND	7
IN124V1	8

1 TC PWB

SMR-0B-VN		SMP-0B-VNC	
1	2/TUD	1	2
2	D-GND	2	D-GND
3	SVNPD+R	3	SVNPD+R
4	/2TURC	4	(NC)
5	24V3	5	24V3
6	D-GND	6	(NC)
7	/2TCGRU	7	(NC)
8	F-GND	8	F-GND

179228-3		SMP-02V-NC		SMR-02V-N	
1	/2TURC	1	1	1	1
2	D-GND	2	2	2	2
3	SVNPD+R	3	3	3	3

QRIP4-32P-C(01)		QRIP4-32S-C(01)	
1	2/TUD	1	2/TUD
2	24V3	2	24V3
3	D-GND	3	D-GND
4	24V3	4	24V3
5	2/TUD	5	2/TUD
6	24V3	6	24V3
7	2/TUD	7	2/TUD
8	24V3	8	24V3

CN-18 832B-PHDSS	
D-GND	1
D-GND	2
D-GND	3
D-GND	4
D-GND	5
D-GND	6
D-GND	7
D-GND	8
D-GND	9
D-GND	10
D-GND	11
D-GND	12
D-GND	13
D-GND	14
D-GND	15
D-GND	16
D-GND	17
D-GND	18
D-GND	19
D-GND	20
D-GND	21
D-GND	22
D-GND	23
D-GND	24
D-GND	25
D-GND	26
D-GND	27
D-GND	28
D-GND	29
D-GND	30
D-GND	31
D-GND	32

CN-12 832B-PHDSS	
/BTM_CLK	29
/BTM_D	31
/BTM_LD	30
/BTM_BFAAKE	32

CN-16(1/2) 828B-PHDSS	
/1TURC_1	7
24V3	9
/DVM_K CK	11
/DVM_K D	12
/DVM_K LD	15
/1TURC_2	8
24V3	10

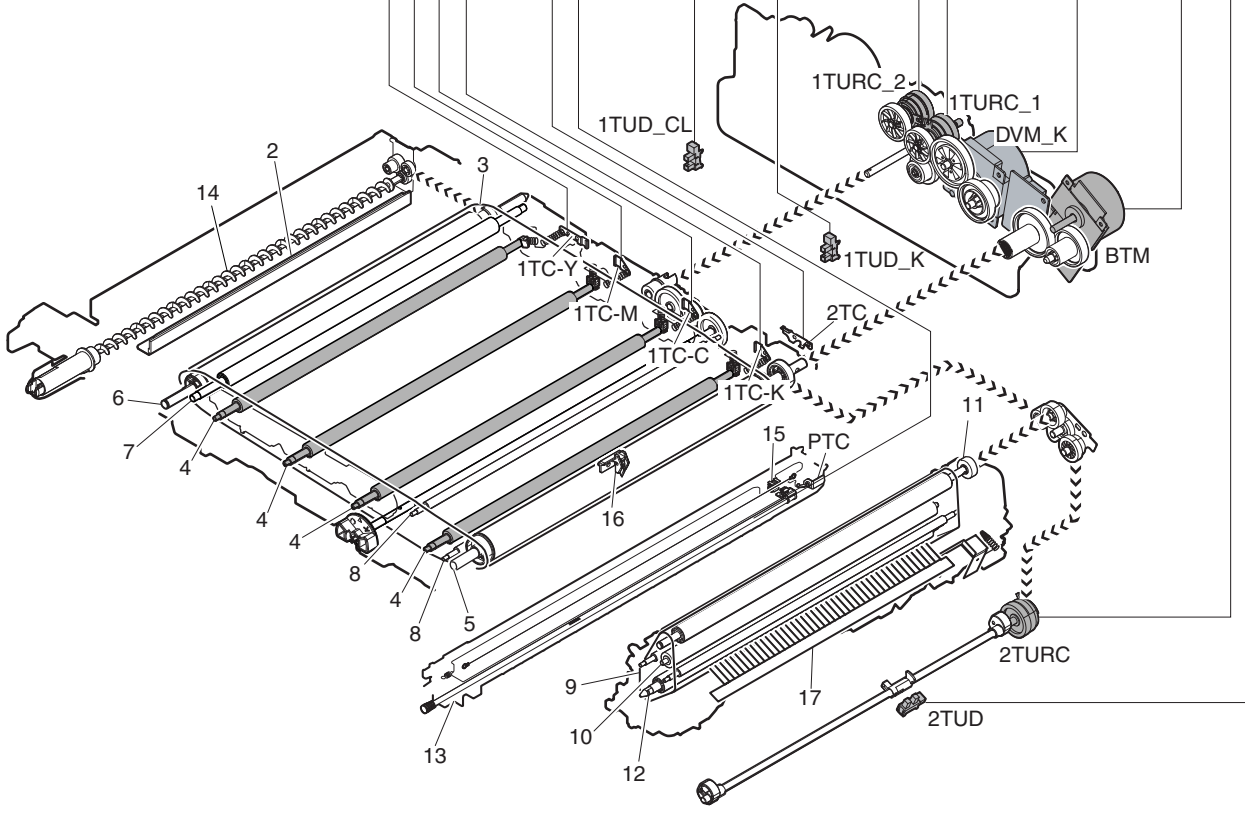

Signal name	Name	Function/Operation
1TC (CMY)	Primary transfer voltage (CMY)	Flows the transfer current to the primary transfer belt, and transfers toner images from the OPC drum to the transfer belt.
1TC (K)	Primary transfer voltage (K)	Flows the transfer current to the primary transfer belt, and transfers toner images from the OPC drum to the transfer belt.
1TUD_CL	Transfer mode detector (CL)	Detects separation of the transfer belt and the transfer mode. (Detection is made by combination of 1TUD_CL/1TUD_K signals.)
1TUD_K	Transfer mode detector (BK)	Detects separation of the transfer belt and the transfer mode. (Detection is made by combination of 1TUD_CL/1TUD_K signals.)
1TURC_1	Primary transfer separation clutch 1	Controls separation of the primary transfer unit.
1TURC_2	Primary transfer separation clutch 2	Controls separation of the primary transfer unit.
2TC	Secondary transfer belt voltage	Flows the transfer current to the secondary transfer belt, and transfers toner images from the primary transfer belt to paper.
2TUD	Secondary transfer position detector	Detects the position (separation) of the secondary transfer unit.
2TURC	Secondary transfer separation clutch	Controls separation of the secondary transfer unit.
BTM	Primary transfer belt drive motor	Drives the primary transfer belt.
DVM_K	Developing motor (K)	Drives the developing/black OPC drum (BK)/transfer section.
PTC	PTC voltage	High voltage for PTC

No.	Name	Function/Operation
1	High voltage PWB (TC PWB)	Generates the transfer voltage.
2	Cleaning blade	Cleans residual toner on the primary transfer belt.
3	Primary transfer belt	Transfers toner images of the OPC drum onto the transfer belt.
4	Primary transfer roller (K, C, M, Y)	Applies a high positive voltage to the primary transfer belt.
5	Primary transfer belt drive roller	Drives the transfer belt. A negative voltage is applied when in the transfer operation, and an alternate high voltage (positive and negative) is applied when cleaning.
6	Primary transfer belt follower roller	Transfer belt follower drive
7	Primary transfer belt tension roller	Applies a tension to the transfer belt.
8	PTC opposed roller	Flows the PTC current to the GND.
9	Secondary transfer belt	Transfers toner images on the primary transfer belt to paper.
10	Secondary transfer roller	Connects the secondary transfer belt to the GND, and flows the transfer current.
11	Secondary transfer belt drive roller	Drives the transfer belt.
12	Secondary transfer belt follower roller	Transfer belt follower drive
13	PTC unit	Reduces positive charges on the primary transfer belt, and improves the transfer efficiency.
14	Primary transfer waste toner transport screw	Transports waste toner in the primary transfer cleaning unit to the waste toner collection section.
15	PTC cleaner	Clean the PTC wire.
16	Separation pawl	Separates paper after transfer.
17	Discharge brush	Discharges the secondary transfer belt surface after transfer to neutralize it.

**b. Process registration sensor section**

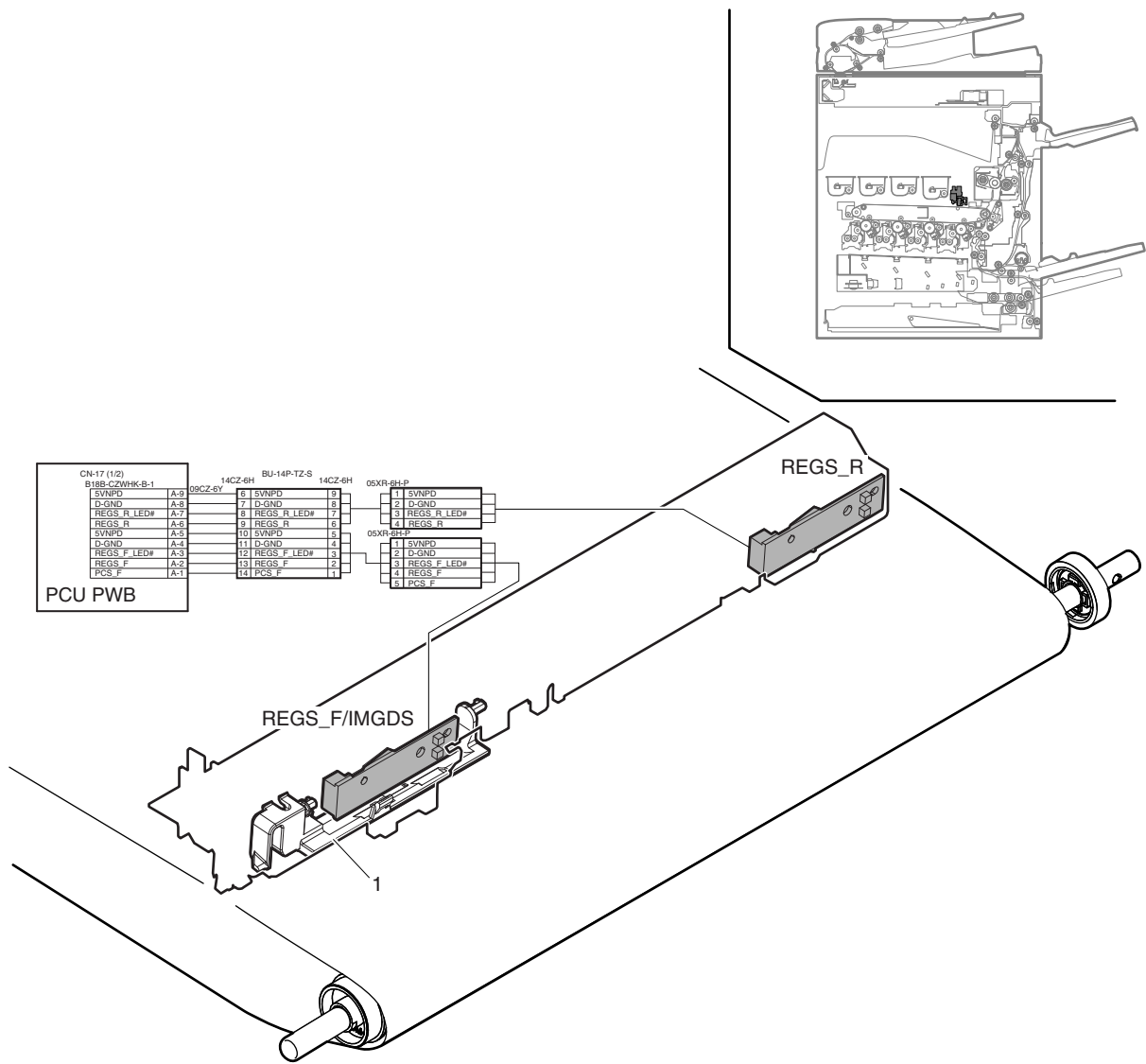

Signal name	Name	Function/Operation
REGS_F/IMGDS	Registration sensor F (Inmate density sensor)	Detects color shift. (F side) / Detects the toner patch density.
REGS_R	Registration sensor R (Inmate density sensor)	Detects color shift. (R side) / Detects the toner patch density.

No.	Name	Function/Operation
1	Standard reflection plate	Used as the standard reflection plate for the sensitivity adjustment of the registration sensor F (image density sensor). When the sensor sensitivity adjustment is performed, the primary transfer unit lifts up and the plate is shifted to the opposed position of the sensor mechanically in conjunction with.

## (2) Operational descriptions

### a. Transfer

#### a-1. Transfer, cleaning operation

##### Transfer operation

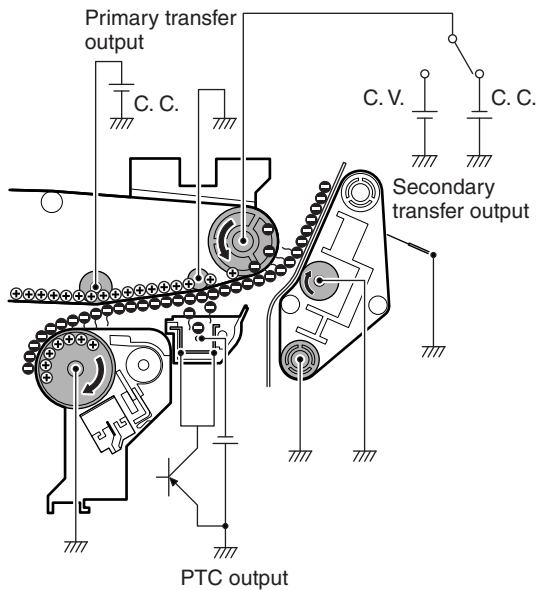

A high positive voltage is applied to the primary transfer roller to transfer toner images from the OPC drum to the primary transfer belt.

Negative electronic charges are generated by the PTC unit, supplying negative charges to toner.

This operation improves the transfer efficiency in the secondary transfer.

Then a high negative voltage is applied to the primary transfer drive roller, to transfer toner images from the primary transfer belt to paper.

##### Primary transfer cleaning operation

The primary transfer belt is cleaned mechanically by the cleaning blade.

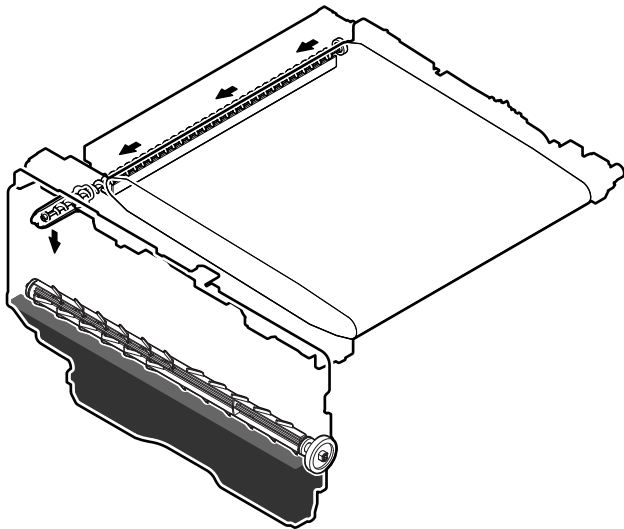

Remaining toner removed from the primary transfer belt is transported to the waste toner collection section by the waste toner transport screw.

##### Secondary transfer cleaning

A high positive voltage is applied to the primary transfer belt to attach unnecessary toner to the primary transfer belt, and it is cleaned by the primary transfer belt cleaning.

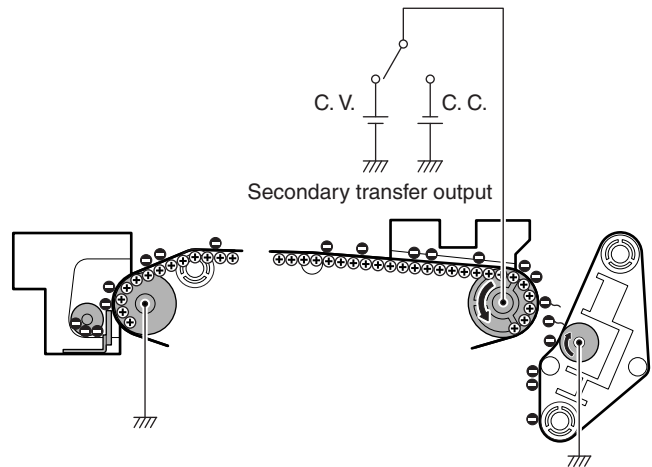

##### Primary transfer belt mode select

There are three kinds of modes of the transfer belt: the free position, the color print mode, and the monochrome print mode.

Mode select is made with the developing motor, the mode select clutches 1TURC1 and 1TURC2.

When the roller separation clutch is turned ON, the transfer cam rotates, and the primary transfer link in conjunction with the cam is shifted in the arrow direction, separating the transfer roller.

The color transfer rollers (C, M, and Y) and the black transfer roller (K) perform an independent separation operation, and the mode state is detected by the combination of the transfer mode detector 1TUD\_CL and 1TUD\_K signals.

To select the rotating direction of the mode select cam, two mode select clutches 1TURC1 and 1TURC2 are used.

The two mode select clutches are used to select the mode in the shortest time.

Mode	Transfer mode detector	
	1TUD_CL	1TUD_K
Monochrome print mode	ON	ON
Color print mode	OFF	ON
Free position	ON	OFF

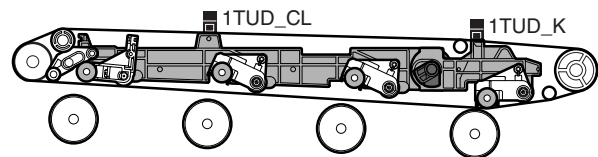

Monochrome print mode

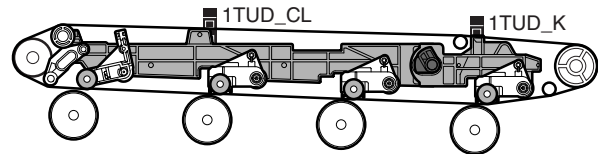

Color print mode

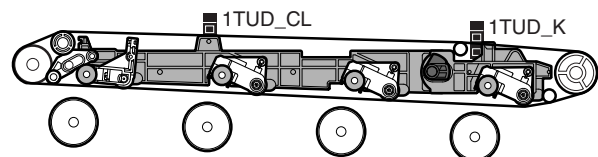

Free position

**b. Image density detection and registration detection operation**

The image density detection and the image registration detection are performed the sensors which are provided separately on the front frame side and the rear frame side.

**b-1. Functions and operations of the color image density sensor and the image registration sensor F (REGS F) provided on the front frame side**

When the process control is performed with one sensor, the color toner patch density is detected. When the image registration adjustment is performed, the image registration shift on the front frame side is detected.

A shutter plate is provided on the sensor. Before execution of the process control and the automatic registration adjustment, the standard reflection plate is closed and the sensor sensitivity adjustment is performed by using the standard reflection plate.

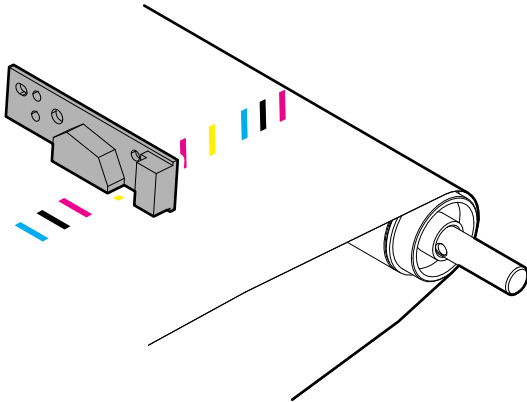

**b-2. Functions and operations of the black image density sensor and the image registration sensor R (REGS R) provided on the rear frame side**

When the process control is performed with one sensor, the black toner patch density is detected. When the image registration adjustment is performed, the image registration shift on the rear frame side is detected.

The sensor sensitivity adjustment is performed by using the standard reflection plate before execution of the process control and the automatic registration adjustment.

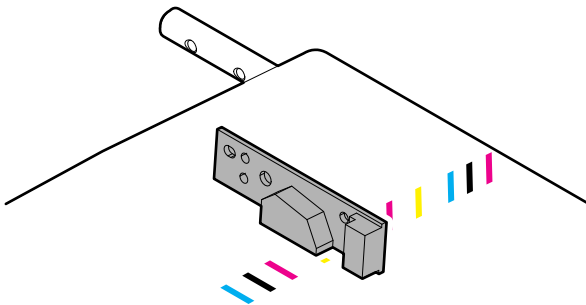

## J. Waste toner collection section

### (1) Electrical and mechanism relation diagram

#### a. 18cpm/20cpm machine

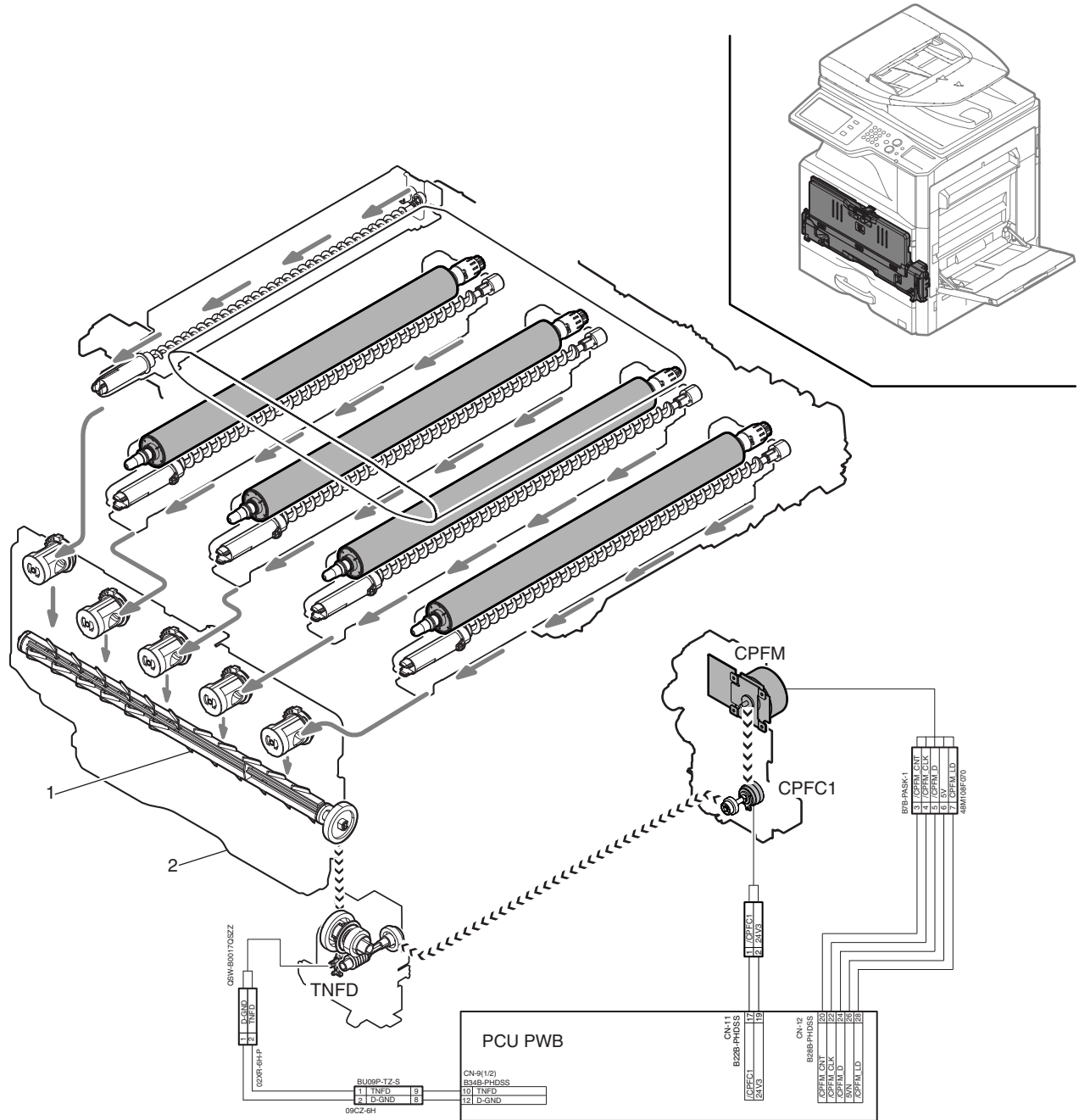

Signal name	Name	Function/Operation
CPFC1	Tray vertical transport clutch 1	Controls the transport roller of the paper feed tray 1 section.
CPFM	Paper feed motor	Drives the paper feed section.
TNFD	Waste toner full detector	Detects full of waste toner.

No.	Name	Function/Operation
1	Waste toner transport screw	Transports waste toner to the waste toner box.
2	Waste toner box	Collects waste toner.

b. 23cpm/26cpm/31cpm/36cpm machine

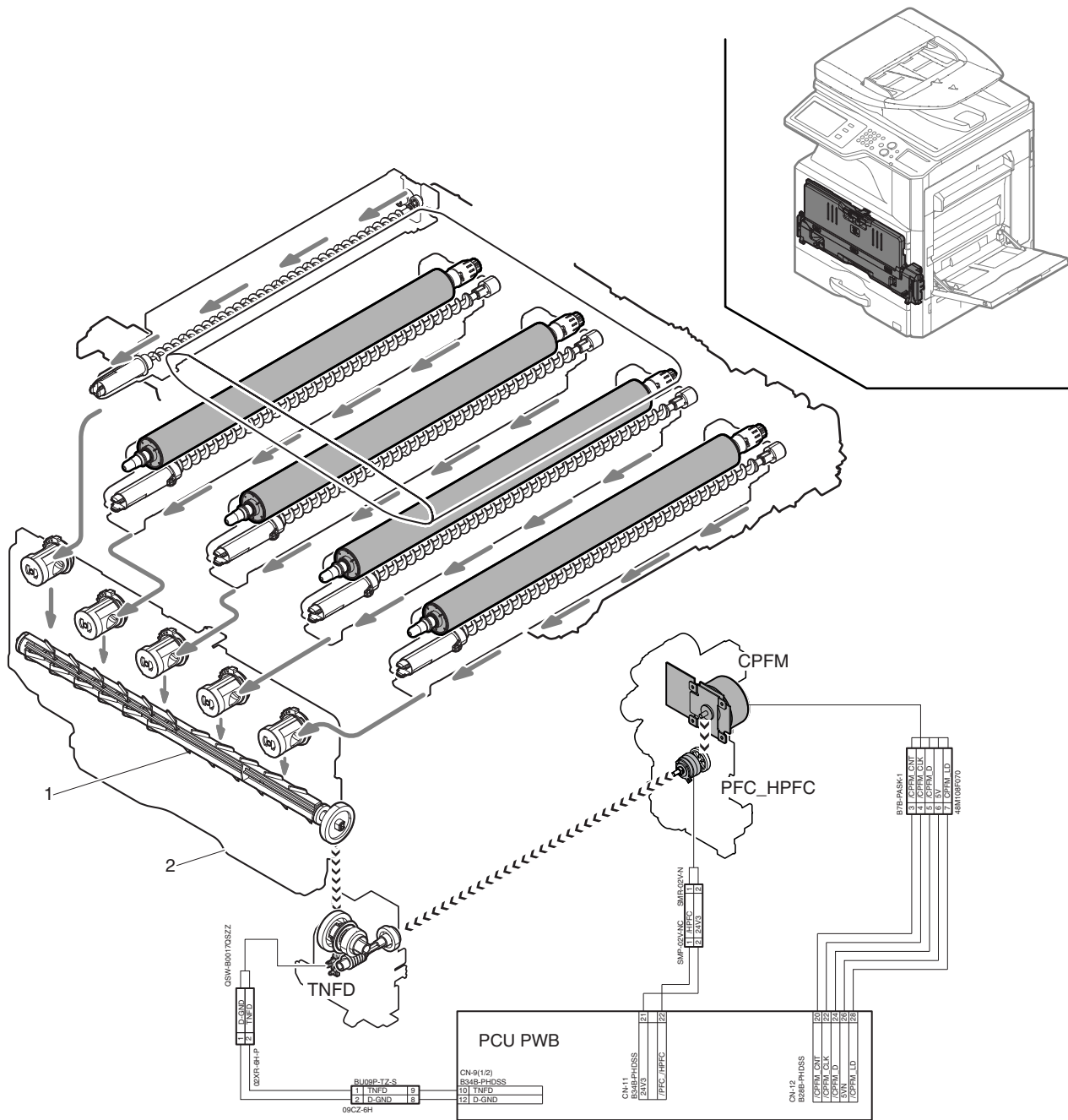

Signal name	Name	Function/Operation
CPFM	Paper feed motor	Drives the paper feed section.
PFC_HPFC	Transport roller clutch	Controls the transport roller 4. / Drives the waste toner transport section.
TNFD	Waste toner full detector	Detects full of waste toner.

No.	Name	Function/Operation
1	Waste toner transport screw	Transports waste toner to the waste toner box.
2	Waste toner box	Collects waste toner.



## (2) Operational descriptions

### a. Waste toner full detection operation

Waste toner generated in the OPC drum and the primary transfer cleaning section is transported to the waste toner box by the waste toner transport screw which is driven by the paper feed motor.

The toner collection box section is provided with the waste toner full detection mechanism. When the waste toner quantity in the toner collection box becomes full, the rotation load of the waste toner transport screw increases and the waste toner transport screw drive coupler is stranded to turn ON the waste toner full detector (TNFD).

When the waste toner full detector is turned ON continuously for 1 sec, it is judged as near end, and the message is display to indicate that the replacement of the toner collection box is approaching.

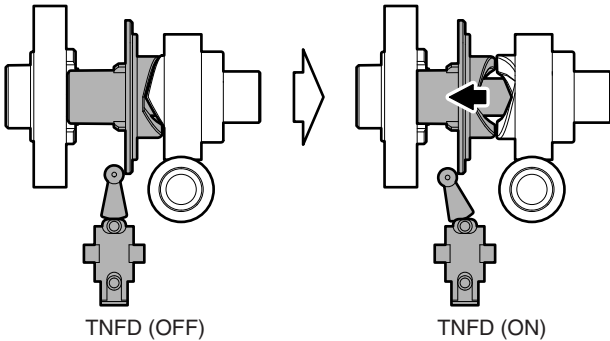
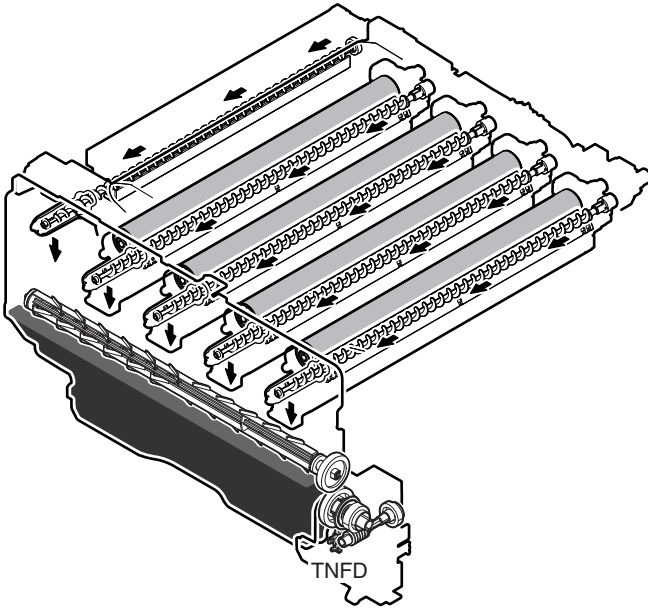

# 10. Fusing section

## A. Electrical and mechanism relation diagram

### (1) 18cpm/20cpm/23cpm machine

#### a. 18cpm/20cpm machine

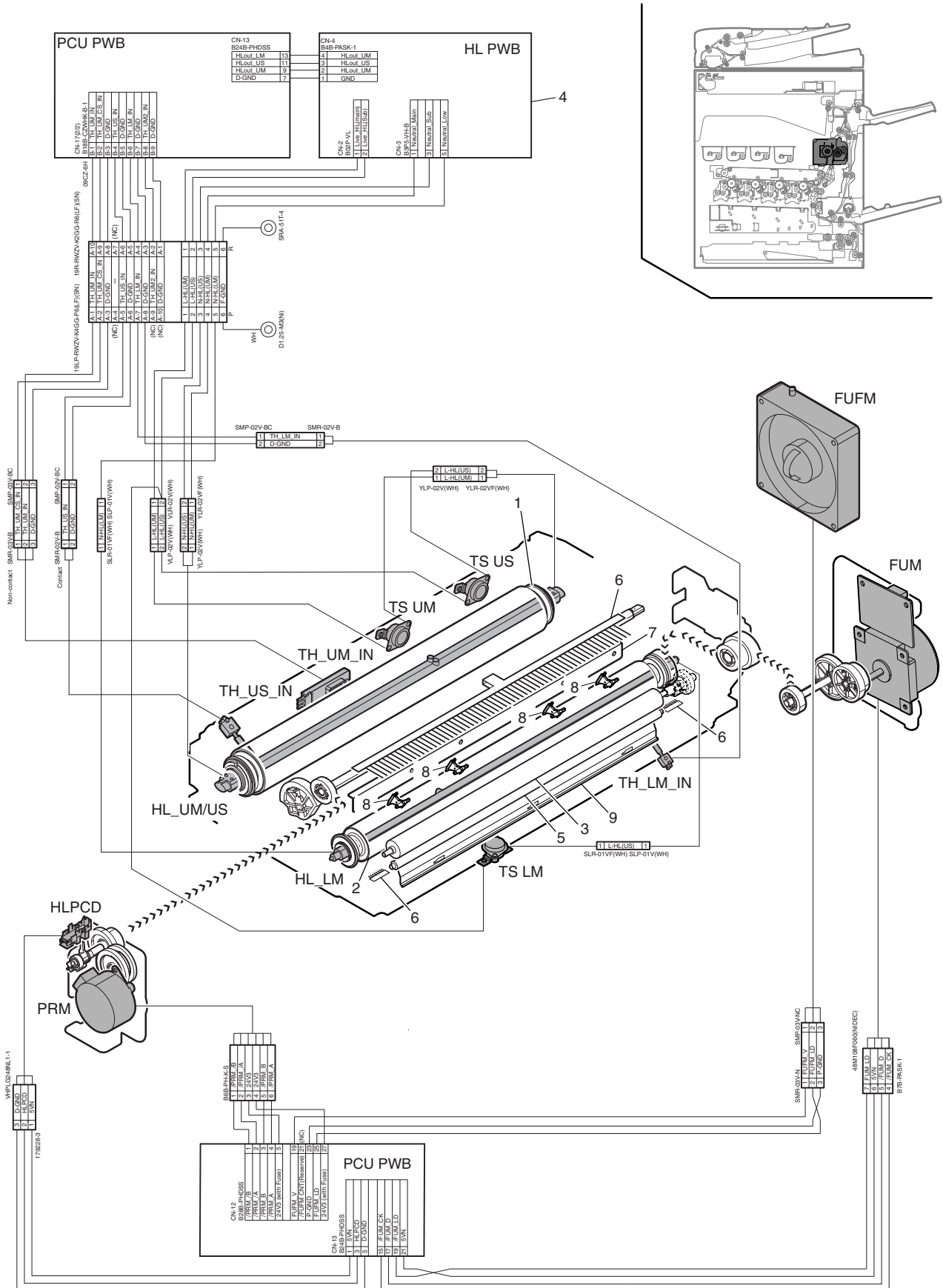

b. 23cpm machine

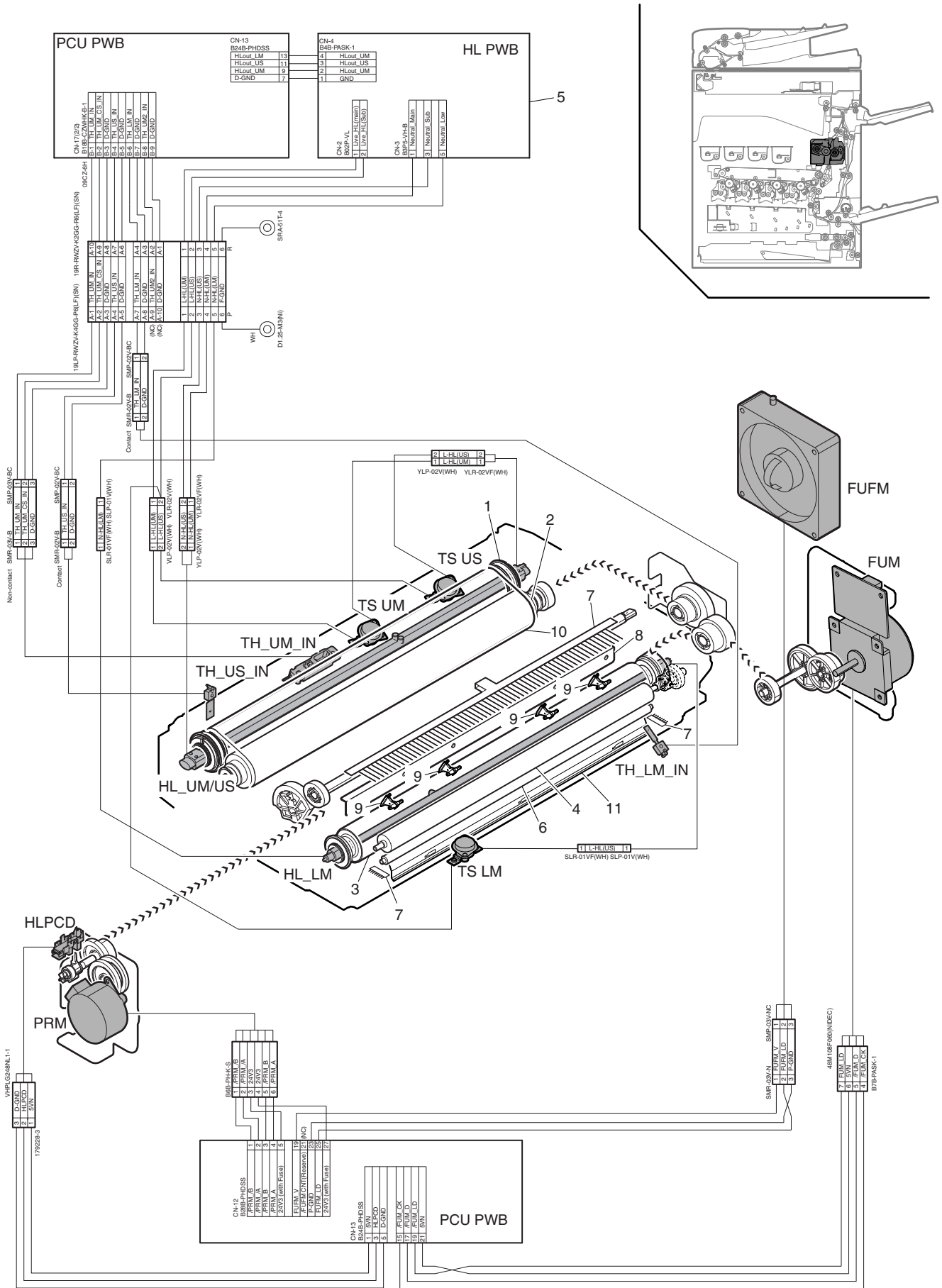

Signal name	Name	Function/Operation
FUFM	Fusing cooling fan	Cools the fusing section and the paper exit section.
FUM	Fusing motor	Drives the fusing section.
HL_LM	Heater lamp (HL_LM)	Heats the fusing roller (B).
HL_UM/US	Heater lamp (HL_UM/US)	Heats the fusing roller (F1), and fusing belt. (23cpm machine)/Heats the fusing roller (F). (18cpm/20cpm machine)
HLPCD	Fusing pressure detector	Detects the fusing pressure state.
PRM	Fusing pressure control motor	Controls ON/OFF of the fusing roller pressure.
TH_LM_IN	Fusing temperature sensor	Detects the surface temperature of the fusing roller (B).
TH_UM_IN	Fusing temperature sensor (Main)	Detects the surface temperature at the center of the fusing belt.
TH_US_IN	Fusing temperature sensor (Sub)	Detects the suffered temperature at the edge section of the fusing belt.
TS LM	Thermostat LM	Shuts down the heater lamp (HL_LM) circuit when the fusing section is overheated.
TS UM	Thermostat UM	Shuts down the heater lamp (HL_UM) circuit when the fusing section is overheated. (Center section)
TS US	Thermostat US	Shuts down the heater lamp (HL_US) circuit when the fusing section is overheated. (Edge section)

No.	Name	Function/Operation
1	Fusing roller (F1)	Heats the fusing belt. (23cpm machine)
2	Fusing roller (F2)	The cushion layer of the roller forms a wide nip between the fusing belt and fusing roller (B). (23cpm machine)/ Heats the paper surface to fuse toner on the paper. (18cpm/20cpm machine)
3	Fusing roller (B)	Heats the paper surface to fuse toner on the paper.
4	Oil roller	Silicon oil is included to improve fusing separation capability and cleaning capability.
5	HL control PWB	Drives the heater lamp.
6	Cleaning roller (Backup roller)	Attach toner or foreign materials, and clean the oil roller.
7	Discharge brush	Discharges static electricity generated in the fusing section to the ground.
8	Separation plate	Separates the whole surface of paper. (non-contact)
9	Separation pawl	Separates fusing roller (B) when it is attached.
10	Fusing belt	Heats the front surface of paper to fuse toner on the paper. (23cpm machine)
11	Scraper	Removes toner and foreign materials attached to the cleaning roller (backup roller).

(2) 26cpm/31cpm(A) machine

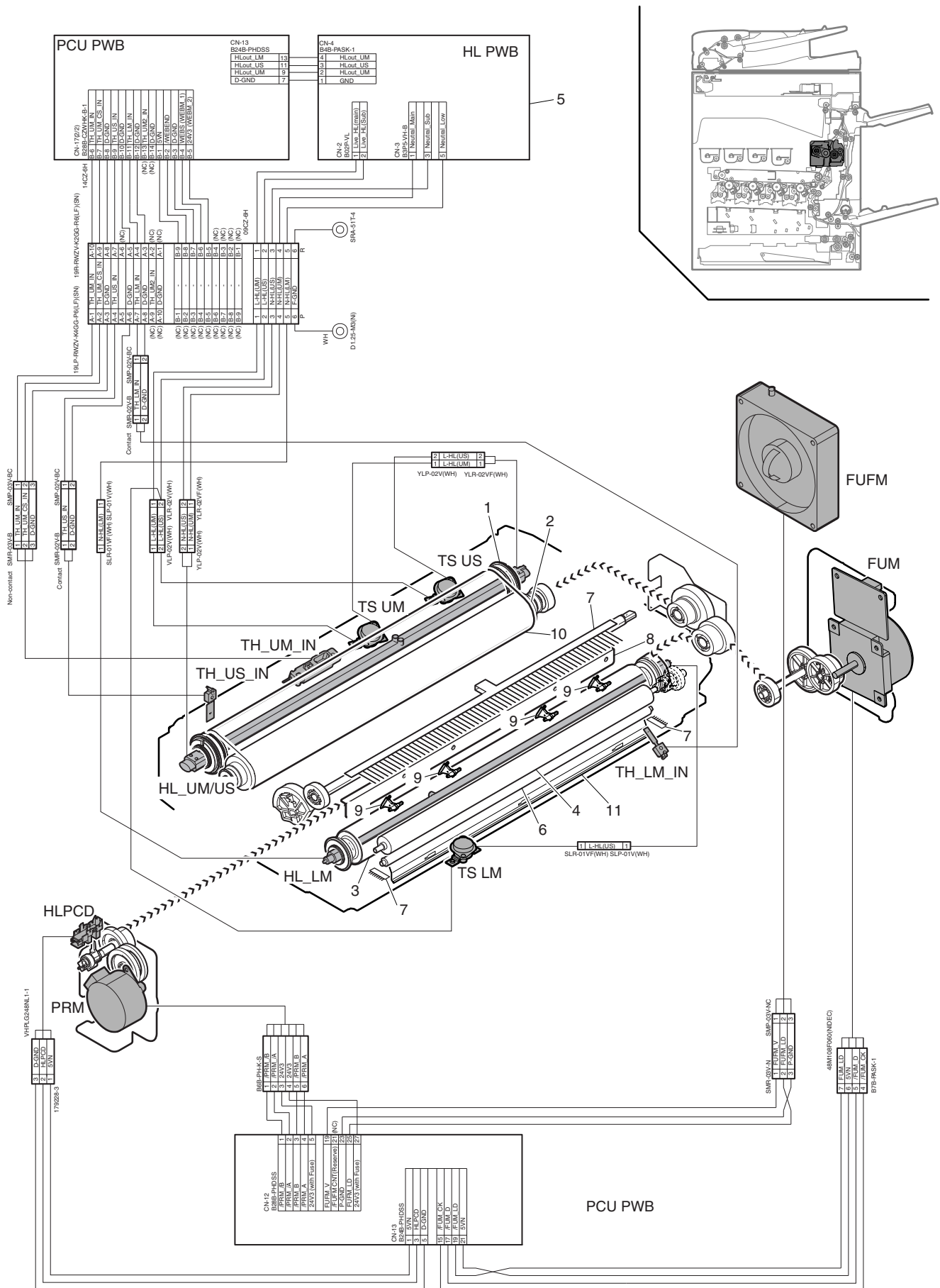

Signal name	Name	Function/Operation
FUFM	Fusing cooling fan	Cools the fusing section and the paper exit section.
FUM	Fusing motor	Drives the fusing section.
HL_LM	Heater lamp (HL_LM)	Heats the fusing roller (B).
HL_UM/US	Heater lamp (HL_UM/US)	Heats the fusing roller (F1), and fusing belt.
HLPCD	Fusing pressure detector	Detects the fusing pressure state.
PRM	Fusing pressure control motor	Controls ON/OFF of the fusing roller pressure.
TH_LM_IN	Fusing temperature sensor	Detects the surface temperature of the fusing roller (B).
TH_UM_IN	Fusing temperature sensor (Main)	Detects the surface temperature at the center of the fusing belt.
TH_US_IN	Fusing temperature sensor (Sub)	Detects the suffered temperature at the edge section of the fusing belt.
TS LM	Thermostat LM	Shuts down the heater lamp (HL_LM) circuit when the fusing section is overheated.
TS UM	Thermostat UM	Shuts down the heater lamp (HL_UM) circuit when the fusing section is overheated. (Center section)
TS US	Thermostat US	Shuts down the heater lamp (HL_US) circuit when the fusing section is overheated. (Edge section)

No.	Name	Function/Operation
1	Fusing roller (F1)	Heats the fusing belt.
2	Fusing roller (F2)	The cushion layer of the roller forms a wide nip between the fusing belt and fusing roller (B).
3	Fusing roller (B)	Heats the back surface of paper to fuse toner on the paper.
4	Oil roller	Silicon oil is included to improve fusing separation capability and cleaning capability.
5	HL control PWB	Drives the heater lamp.
6	Cleaning roller (Backup roller)	Attach toner or foreign materials, and clean the oil roller.
7	Discharge brush	Discharges static electricity generated in the fusing section to the ground.
8	Separation plate	Separates the whole surface of paper. (non-contact)
9	Separation pawl	Separates fusing roller (B) when it is attached.
10	Fusing belt	Heats the front surface of paper to fuse toner on the paper.
11	Scraper	Removes toner and foreign materials attached to the cleaning roller (backup roller).



Signal name	Name	Function/Operation
FUFM	Fusing cooling fan	Cools the fusing section and the paper exit section.
FUM	Fusing motor	Drives the fusing section.
HL_LM	Heater lamp (HL_LM)	Heats the fusing roller (B).
HL_UM/US	Heater lamp (HL_UM/US)	Heats the fusing roller (F1), and fusing belt.
HLPCD	Fusing pressure detector	Detects the fusing pressure state.
PRM	Fusing pressure control motor	Controls ON/OFF of the fusing roller pressure.
TH_LM_IN	Fusing temperature sensor	Detects the surface temperature of the fusing roller (B).
TH_UM_IN	Fusing temperature sensor (Main)	Detects the surface temperature at the center of the fusing belt.
TH_US_IN	Fusing temperature sensor (Sub)	Detects the suffered temperature at the edge section of the fusing belt.
TS LM	Thermostat LM	Shuts down the heater lamp (HL_LM) circuit when the fusing section is overheated.
TS UM	Thermostat UM	Shuts down the heater lamp (HL_UM) circuit when the fusing section is overheated. (Center section)
TS US	Thermostat US	Shuts down the heater lamp (HL_US) circuit when the fusing section is overheated. (Edge section)

No.	Name	Function/Operation
1	Fusing roller (F1)	Heats the fusing belt.
2	Fusing roller (F2)	The cushion layer of the roller forms a wide nip between the fusing belt and fusing roller (B).
3	Fusing roller (B)	Heats the back surface of paper to fuse toner on the paper.
4	Oil roller	Silicon oil is included to improve fusing separation capability and cleaning capability.
5	HL control PWB	Drives the heater lamp.
6	Cleaning roller (Backup roller)	Attach toner or foreign materials, and clean the oil roller.
7	Discharge brush	Discharges static electricity generated in the fusing section to the ground.
8	Separation plate	Separates the whole surface of paper. (non-contact)
9	Separation pawl	Separates fusing roller (B) when it is attached.
10	Fusing belt	Heats the front surface of paper to fuse toner on the paper.
11	Scraper	Removes toner and foreign materials attached to the cleaning roller (backup roller).





Signal name	Name	Function/Operation
FUFM	Fusing cooling fan	Cools the fusing section and the paper exit section.
FUM	Fusing motor	Drives the fusing section.
HL_LM	Heater lamp (HL_LM)	Heats the fusing roller (B).
HL_UM/US	Heater lamp (HL_UM/US)	Heats the fusing roller (F1), and fusing belt.
HLPCD	Fusing pressure detector	Detects the fusing pressure state.
PRM	Fusing pressure control motor	Controls ON/OFF of the fusing roller pressure.
TH_LM_IN	Fusing temperature sensor	Detects the surface temperature of the fusing roller (B).
TH_UM_IN	Fusing temperature sensor (Main)	Detects the surface temperature at the center of the fusing belt.
TH_US_IN	Fusing temperature sensor (Sub)	Detects the suffered temperature at the edge section of the fusing belt.
TS LM	Thermostat LM	Shuts down the heater lamp (HL_LM) circuit when the fusing section is overheated.
TS UM	Thermostat UM	Shuts down the heater lamp (HL_UM) circuit when the fusing section is overheated. (Center section)
TS US	Thermostat US	Shuts down the heater lamp (HL_US) circuit when the fusing section is overheated. (Edge section)
WEBEND	Web end detector	Detects web end of the fusing unit.

No.	Name	Function/Operation
1	Fusing roller (F1)	Heats the fusing belt.
2	Fusing roller (F2)	The cushion layer of the roller forms a wide nip between the fusing belt and fusing roller (B).
3	Fusing roller (B)	Heats the back surface of paper to fuse toner on the paper.
4	Fusing web roller	Cleans the fusing roller (B) and the fusing belt.
5	HL control PWB	Drives the heater lamp.
6	Discharge brush	Discharges static electricity generated in the fusing section to the ground.
7	Separation plate	Separates the whole surface of paper. (non-contact)
8	Separation pawl	Separates fusing roller (B) when it is attached.
9	Fusing belt	Heats the front surface of paper to fuse toner on the paper.

## B. Outline of operations

This machine employs the fusing system by the belt.

**The features of the belt-type fusing system are as follows:**

- 1) Short warm-up time
- 2) Low power consumption
- 3) Wide nip providing high fusing capability

## C. Heater lamp driving

The surface temperature of the heat roller and the fusing belt detected by the fusing temperature sensor is sent to the PCU. If the temperature is lower than the specified temperature, the heater lamp lighting signal is sent from the PCU to the heater lamp drive circuit in the HL PWB.

When the power triac in the heater lamp drive circuit is turned ON, the AC power is supplied to the heater lamp to light the lamp and heat the fusing belt.

A thermostat is provided as a safety device against an abnormally high temperature in the heat roller and the fusing belt.

When the thermostat is opened, the AC power supply to the heater lamp is cut off.

The heater lamp is arranged to fusing roller (F1) and fusing roller (B).

In heater lamp (HL\_UM/US), two lamps are integrated into one.

### Heater lamp operations

Heater lamp	Operation
Heater lamp (HL_UM)	Heats fusing roller (F1) and the fusing belt.
Heater lamp (HL_US)	Heats fusing roller (F1) and the fusing belt. Turns ON continuously when in warming up.
Heater lamp (HL_LM)	Heats fusing roller (B). Does not turn ON while heater lamp (HL_UM) and heater lamp (HL_LS) light up.

## D. Fusing operation

Color toner (Y, M, C, and K) on paper is heated and pressed by the fusing belt, fusing roller (F2), and fusing roller (B) to be fused on paper.

Toner in the four layers on the paper is fused by heating from up and down and both sides.

The fusing belt, fusing roller (F2) which is provided with the cushion layer, and fusing roller (B) realize the following operations.

- 1) The nip amount is increased and the heat capacity to paper is increased.
- 2) By pressing with the flexible roller, toner of many layers can be fused without being deformed.
- 3) An even pressure is applied to rough surface of toner (due to the multi-layer composition).

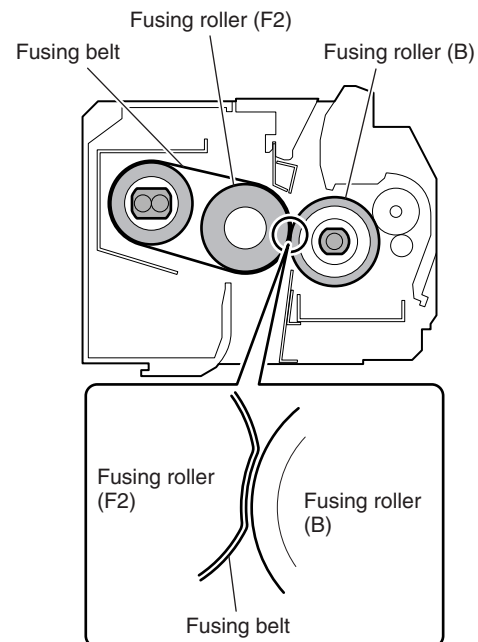

## E. Automatic pressure release system

Normally the upper and lower heat rollers are pressed. When, however, the following conditions are satisfied, the pressure is released.

- When the machine shifts to the preheat mode.
- When the machine shifts to the auto power shut off mode.
- When the power switch of the operation panel is turned OFF.
- When the machine is left for 90 sec under the ready state.
- When in the envelope mode.
- When a jam occurs.

### (1) Pressure release operation

The fusing pressure control motor (PRM) rotates to turn ON the fusing pressure detector (HLPCD) (H level). When the specified time passes after turning ON the fusing pressure detector (HLPCD) (H level) by rotation of the fusing pressure control roller (PRM), the pressure release motor stops to complete the pressure release operation.

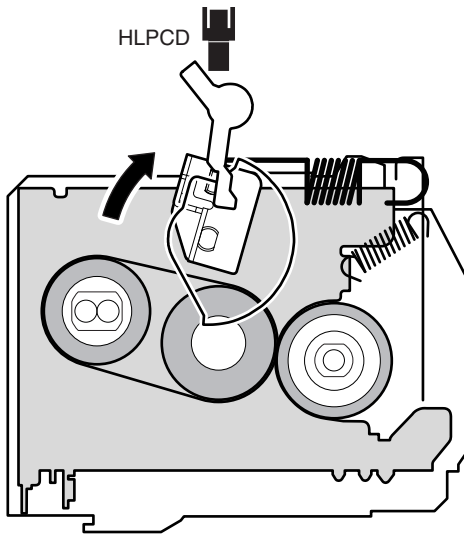

### (2) Pressure release operation

When the end user makes some operations or when the machine receives the Job signal, the fusing pressure control motor (PRM) rotates reversely to drive the pressure release lever to the pressing state.

When the specified time passes from turning OFF the fusing pressure detector (HLPCD), the pressure release motor stops to complete the pressing operation.

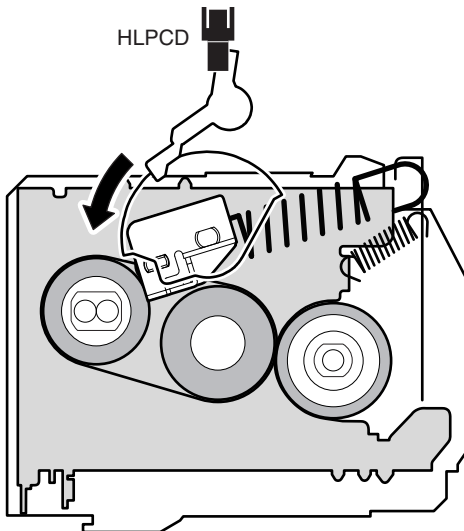

## Important

When turning OFF the main power switch of the machine, be sure to turn OFF the power switch of the operation panel and check to confirm that the LCD display goes off before turning OFF the main power switch.

If the main power switch is turned OFF with the LCD lighted, the power is cut off before completion of the pressure release operation. If this state is kept for a long time, the fusing roller may be deformed.

## F. Fusing section cleaning

### (1) 18cpm/23cpm/26cpm/31cpm machine

In this machine, the fusing section cleaning is performed by using the oil cleaning roller for cleaning the fusing roller.

The cleaning unit is composed of the oil cleaning roller, the metal roller, and the cleaning plate.

Residual toner on the fusing roller (B) is cleaned by the cleaning roller which contains silicon oil.

Residual toner on the metal roller is scraped away by the cleaning plate.

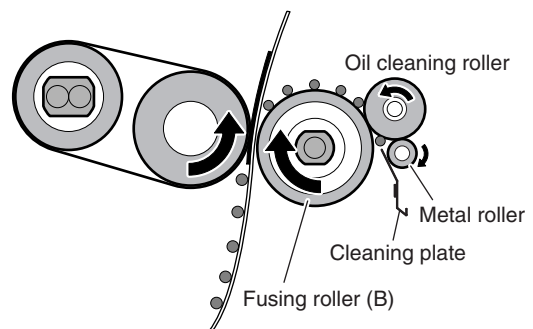

### (2) 36cpm machine

In this machine, the fusing roller (B) is cleaned by the web.

The cleaning unit is composed of the web feed roller, the winding roller, and the backup roller which presses the web onto the fusing roller (B) with the proper pressure.

Residual toner on the fusing roller (B) is cleaned by the web which contains silicon oil.

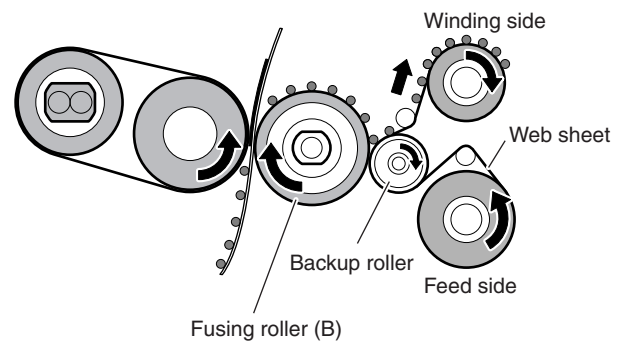

## G. Web life end detection (36cpm machine)

The web life near end is detected by the web print counter. When the life reaches 120K prints, the following message is displayed to notify that the replacement timing is approaching.  
(Maintenance required.: FK3)

The web life end is detected by the web end detector. When the life end is detected, a job is forcibly interrupted even the job is being performed.

After replacing the web with a new one, reset the web life counter and the web send counter to clear the life end state.

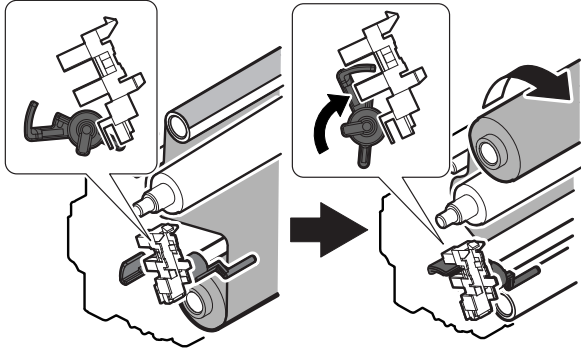

# 11. RSPF section

## A. Electrical and mechanical relation diagram

### (1) Paper feed section

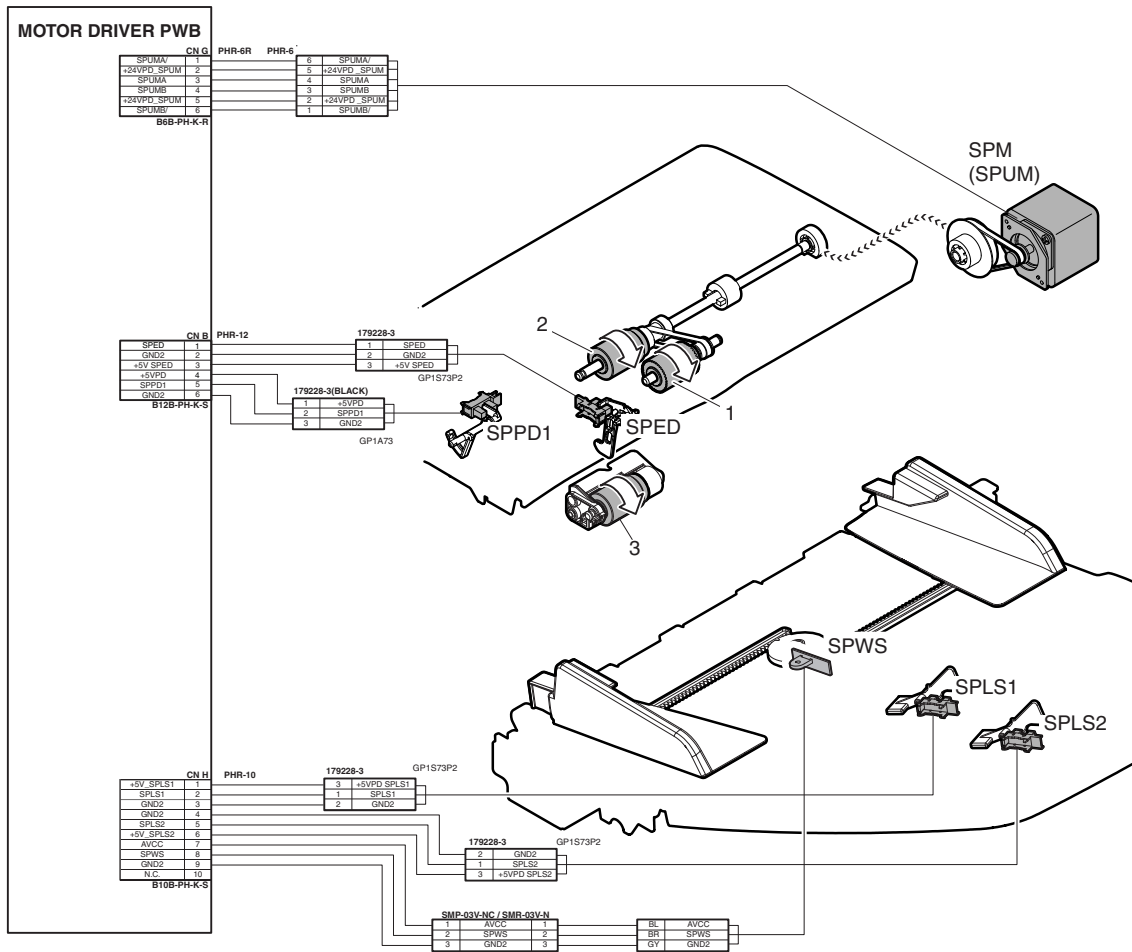
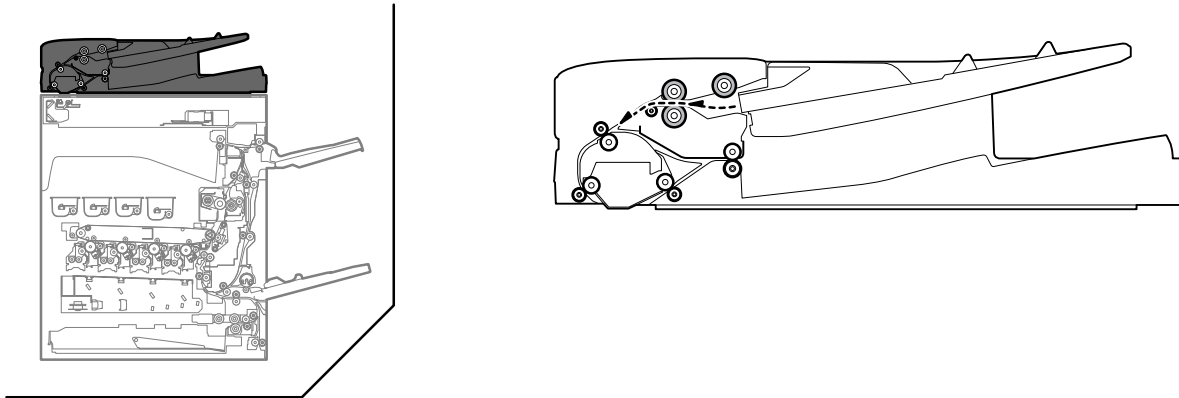

Signal name	Name	Function/Operation
SPED	Document sensor	Detects document empty in the RSPF paper feed tray.
SPLS1	Paper size detector 1	Detects the document length in the RSPF paper feed tray.
SPLS2	Paper size detector 2	Detects the document length in the RSPF paper feed tray.
SPM (SPUM)	RSPF paper feed motor	Feeds a document.
SPPD1	Document transport sensor 1	Detects paper feed and the document size in random paper feed.
SPWS	Document size detector	Detects the document width.

No.	Name	Function/Operation
1	Document pickup roller (RSPF)	Feeds a document to the paper feed roller.
2	Paper feed roller (RSPF)	Feeds a document to the transport section. Makes a warp on paper between the registration roller and this roller to correct the start position of document skew and document image scan.
3	Separation roller (RSPF)	Separates a document to prevent double-feeding.

(2) Transport/paper exit section

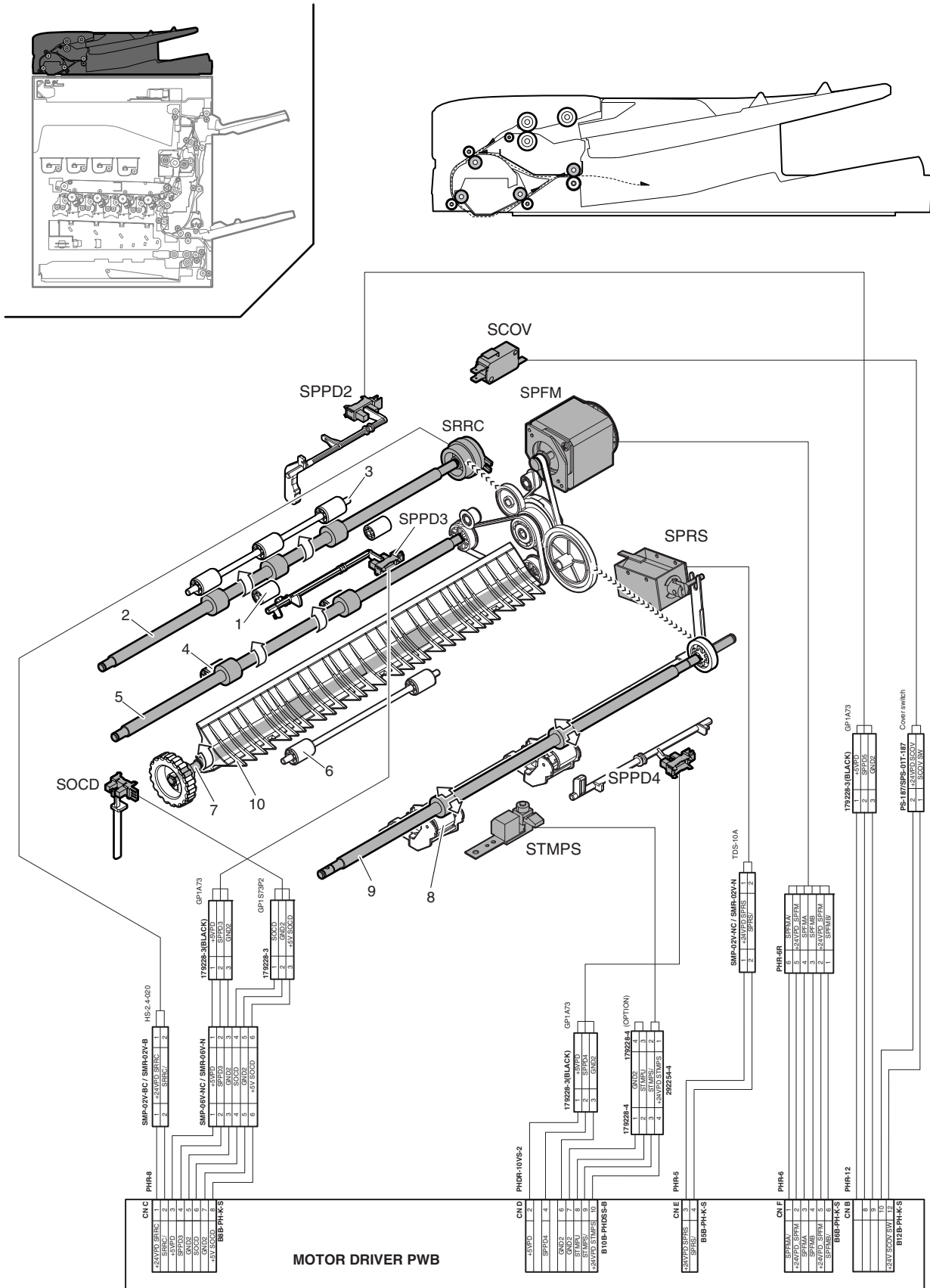

Signal name	Name	Function/Operation
SCOV	RSPF cover open/close detector	Detects open/close of the RSPF cover.
SOCD	RSPF open/close sensor	Detects open/close of the RSPF unit.
SPFM	RSPF transport motor	Transports a document.
SPPD2	Document transport sensor 2	Detects paper pass.
SPPD3	Document transport sensor 3	Detects paper pass.
SPPD4	Document transport sensor 4	Detects paper exit and switchback.
SPRS	Paper exit roller pressure control solenoid (RSPF)	Controls ON/OFF of the transport power of the paper exit roller. (Releases the paper exit roller pressure when reversing paper.)
SRRC	Registration roller clutch (RSPF)	Controls the registration roller. (Controls the timing of document transport.)
STMP5	Stamp solenoid	Drives the finish stamp.

No.	Name	Function/Operation
1	Transport auxiliary roller (RSPF)	Reduces friction between a document and the paper guide to transport the document smoothly to the registration roller.
2	Registration roller (Drive) (RSPF)	Transports a document to the transport roller 2. / Controls the transport timing of the document and adjusts the document scanning timing.
3	Registration roller (Idle) (RSPF)	Apply a pressure to a document and the registration roller to provide the transport power of the transport roller to the document.
4	Transport roller 3 (Idle) (RSPF)	Apply a pressure to a document and the transport roller to provide the transport power of the transport roller to the document.
5	Transport roller 3 (Drive) (RSPF)	Transports a document transported from the document scanning section to the paper exit roller.
6	Transport roller 2 (Idle) (RSPF)	Apply a pressure to a document and the transport roller to provide the transport power of the transport roller to the document.
7	Transport roller 2 (Drive) (RSPF)	Transports a document transported from the registration roller to the document scanning section.
8	Paper exit roller (Idle) (RSPF)	Apply a pressure to a document and the paper exit roller to provide the transport power of the paper exit roller to the document.
9	Paper exit roller (Drive) (RSPF)	Discharges a document. Switchbacks the document and transports it to the registration roller when scanning the back surface.
10	Document reverse gate	Reverses a document when scanning images on the back surface.
11	RSPF driver PWB	Drives the motor, the solenoid, and the clutch in the RSPF section.

## B. Operational descriptions

### (1) Document size detection

Size detection on the document tray

The document width is detected with the RSPF document width sensor (SPWS), and the document length is detected with the RSPF document length sensors (SPLS1, SPLS2). The document size is judged from the document width and the document length according to the table below. When documents of different sizes are mixed and set on the document tray, the largest document size is detected.

	Document size	Document length sensor	
		SPLS1	SPLS2
AB series	A5	OFF	OFF
	B5	OFF	OFF
	11" x 8.5"	OFF	OFF
	A4	OFF	OFF
	B5R	ON	OFF
	A4R	ON	OFF
	8.5" x 13"	ON	ON
	B4	ON	ON
	A3	ON	ON
	11" x 17"	ON	ON
	8.5" x 14"	ON	ON
	8.5" x 13.4"	ON	ON
	8.5" x 13.5"	ON	ON
Inch series	8.5" x 5.5"	OFF	OFF
	11" x 8.5"	OFF	OFF
	A4	OFF	OFF
	11" x 8.5"R	ON	OFF
	8.5" x 13"	ON	ON
	8.5" x 14"	ON	ON
	A3	ON	ON
	11" x 17"	ON	ON
	8.5" x 13.4"	ON	ON

### RSPF unit

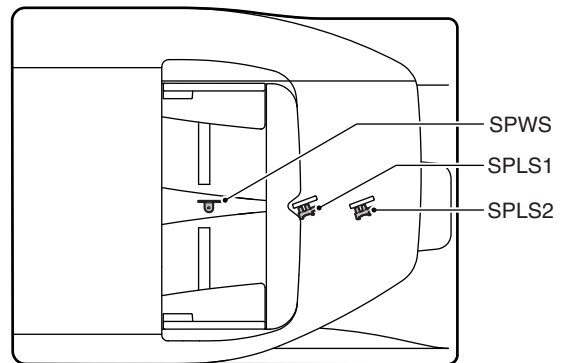

### (2) Document scanning

The document scanning mode is available in 400dpi and 600dpi.

Resolution	Document transport speed
400dpi	259mm/sec
600dpi	173mm/sec

### (3) RSPF paper feed and transport operations

#### a. Paper feed operation

The paper feed motor is turned ON and the power of the paper feed motor is transmitted to the pickup roller and the paper feed roller.

The pickup roller descends to pickup the top document and feed it to the paper feed roller.

The paper feed roller feeds a document to the transport section.

At that time, the document is separated by the separation roller to prevent double-feeding.

#### b. Single face scanning

The lead edge of the fed document is aligned (registration) by the registration roller, and passed through transport roller 1 to the document scanning section, where images are scanned.

Then the document is passed through transport roller 2 to the paper exit roller.

The rollers (the registration roller, transport rollers 1 and 2, the paper exit roller) in the transport section are driven by the transport motor.

The paper exit roller (drive pulley) is separated by the paper exit roller pressure control solenoid.

When the read edge of the document passes the scanning section, the both rollers are brought into close contact to supply the power for paper exit.

- 1) Document set (Document empty sensor ON)

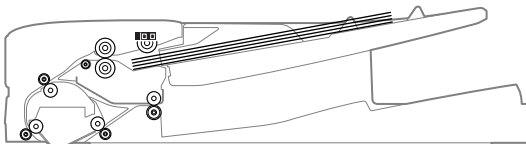

- 2) Paper feed start (1st sheet)

The pick-up roller descends. (The paper feed motor is booted.)  
(The transport motor is booted simultaneously.)

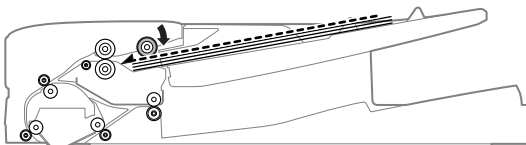

- 3) Registration operation (1st sheet)

(Registration clutch ON)

(When a certain time passes after turning ON the registration clutch, the paper feed motor is turned OFF.)

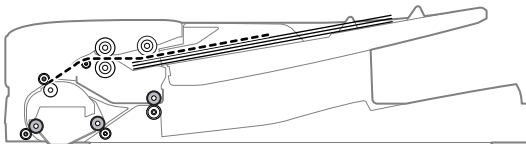

- 4) Scanning start (1st sheet)

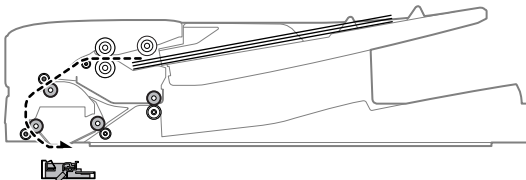

- 5) Paper feed start (2nd sheet)

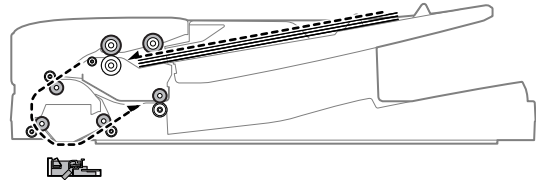

- 6) Scanning complete (1st sheet)/Registration operation (2nd sheet)

(When a certain time passes after turning ON the registration clutch, the paper feed motor is turned OFF.)

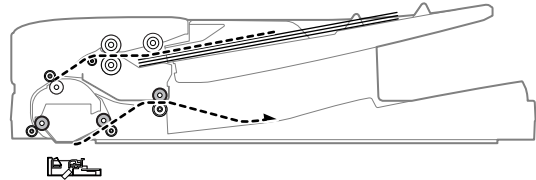

- 7) Scanning start (2nd sheet)

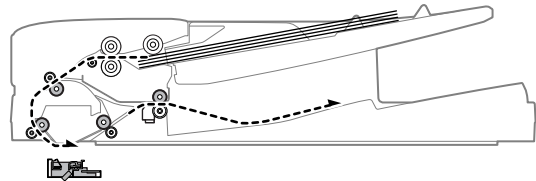

- 8) Paper exit complete (1st sheet)

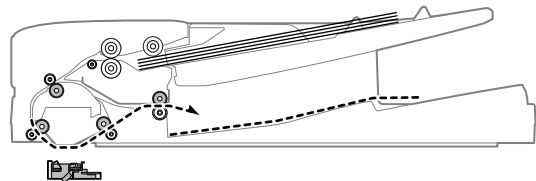

- 9) Scanning complete (2nd sheet)

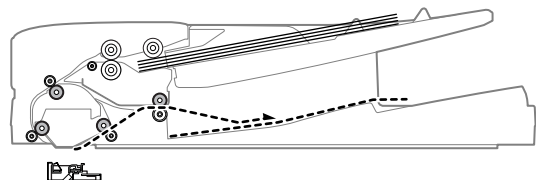

- 10) Paper exit complete (2nd sheet)

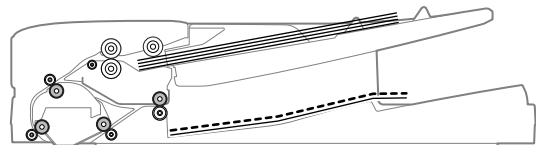

- 11) Pick-up roller lifting up

(After completion of a job, the paper feed motor is rotated reversely at a low speed for a certain time to lift the pickup roller.)

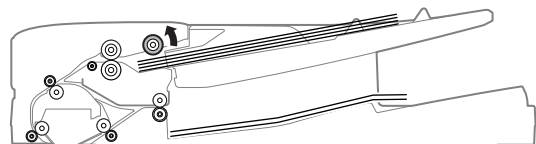



**c. Duplex scanning**

Images on the document surface are scanned, and detection of the rear edge of the document by sensor SPPD3 triggers the following. That is, when the rear edge of the document passes the reverse gate, the transport motor is reversed.

Due to the above operation, the paper exit roller is reversed to switchback the document, returning it to the registration roller section and aligning (registration) the document.

Then the transport motor is rotated normally to transport the document to the scanning section, scanning images on the back surface.

To reset the page order of the documents, the following operations are made which are triggered by the detection of the rear edge of the document. That is, when the rear edge of the document passes the reverse gate, the transport motor is reversed.

Due to the above operation, the paper exit roller is reversed to switchback the document, returning it to the registration roller section and aligning (registration) the document.

Then the transport motor is rotated normally to transport the document to the paper exit section and discharge it.

When a duplex document is scanned, the document lead edge section and the rear edge section intersect. At that timing, the paper exit roller pressure release solenoid is turned ON to make a gap between the paper exit roller (drive) and the paper exit roller (idle).

During the time from when the document rear edge passes the scanning section to when it is switch backed and send to the registration roller section, the paper exit roller pressure release solenoid is turned OFF to keep the paper exit roller (drive) and the paper exit roller (idle) in contact.

- 1) Document set (Document empty sensor ON)



- 2) Paper feed start (1st sheet)  
Pick-up roller descending

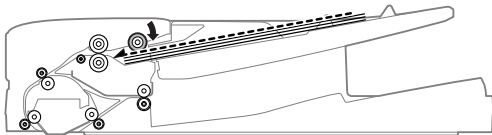

- 3) Registration operation (1st sheet, front surface)

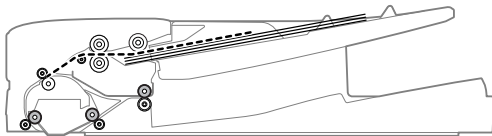

- 4) Scanning start (1st sheet, front surface)

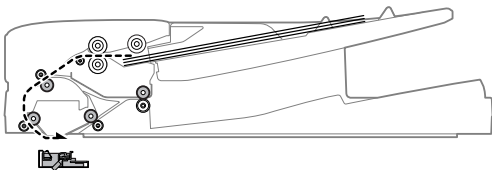

- 5) After completion of scanning, the reverse follower roller is pressed. (Solenoid ON)

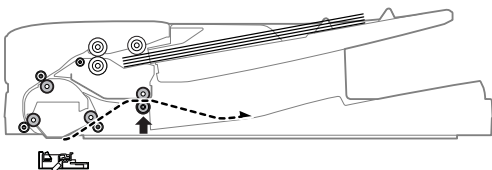

- 6) After stopping the operation, reversing is started.

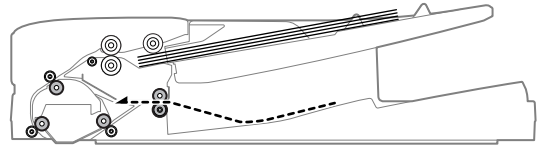

- 7) After reversing, registration operation is executed.

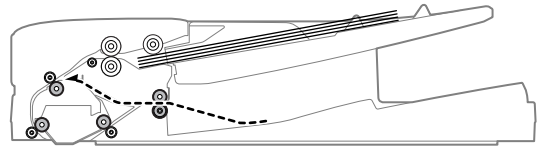

- 8) After turning ON the PS clutch, the reverse follower roller pressure is released.

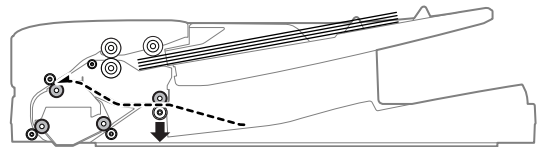

- 9) Scanning start (First sheet, back surface)

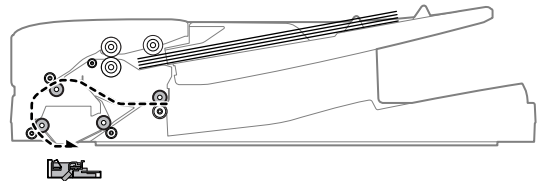

- 10) After completion of scanning, the reverse follower roller is pressed.

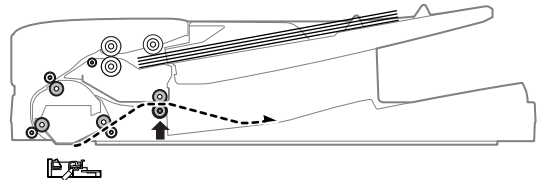

- 11) After stopping the operation, reversing is started.

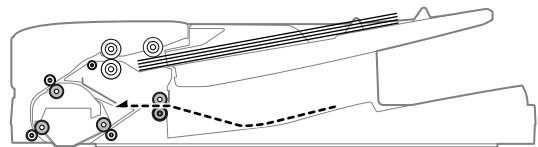

- 12) After reversing, registration operation is executed.

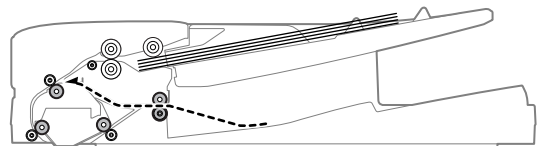

- 13) After turning ON the PS clutch, the reverse follower roller pressure is released.

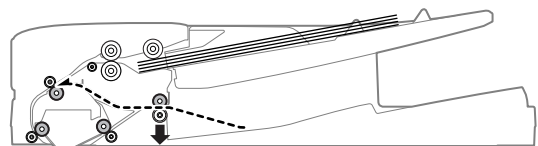

14) Scanning start (Second sheet)

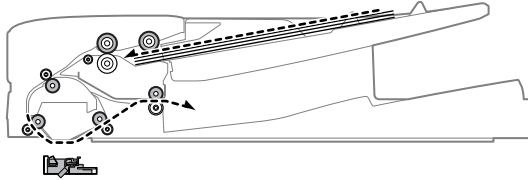

15) After passing the scanning section, the reverse follower roller is pressed.

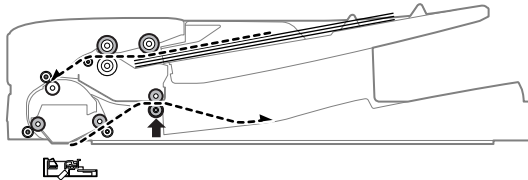

16) After discharge (First sheet), the reverse follower roller pressure is released.

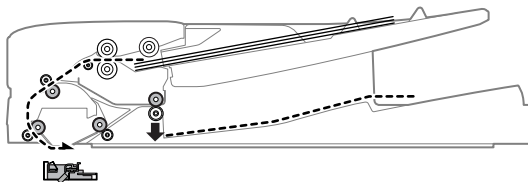

**d. Stamp operation**

1) Document set (Document empty sensor ON)

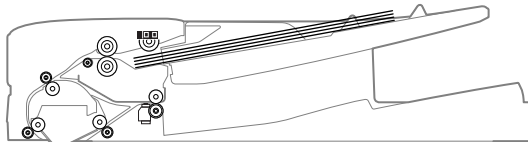

2) Paper feed start (1st sheet)  
Pick-up roller descending (The paper feed motor is booted.)  
(The transport motor is booted simultaneously.)

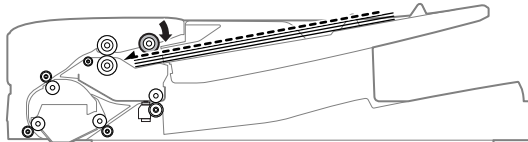

3) Registration operation (1st sheet)  
(Registration clutch ON)  
(When a certain time passes after turning ON the registration clutch, the paper feed motor is turned OFF.)

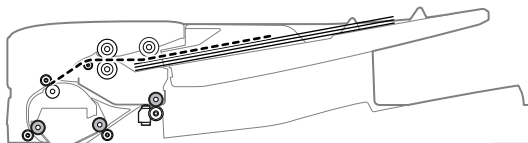

4) Scanning start (1st sheet)

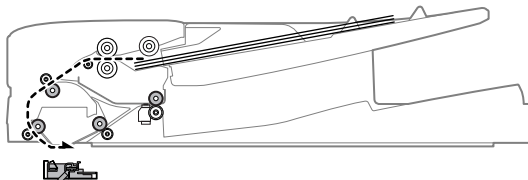

5) Scanning complete (1st sheet)

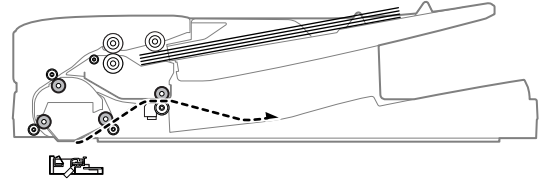

6) Stop at the stamp position/Stamp operation (1st sheet)  
(Stamp solenoid ON)

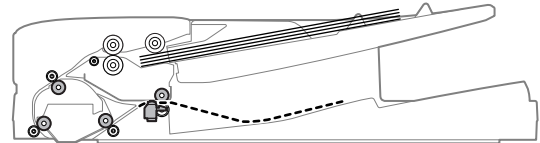

7) Paper exit start (1st sheet)/Preliminary paper feed start (2nd sheet)

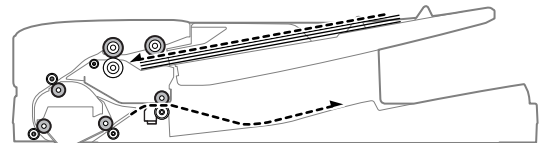

8) Paper exit complete (1st sheet)

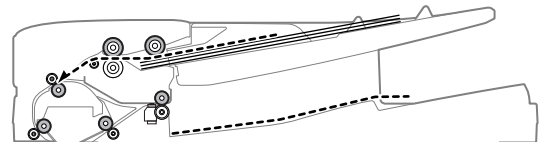

9) Stop at the stamp position/Stamp operation (2nd sheet)  
(Stamp solenoid ON)

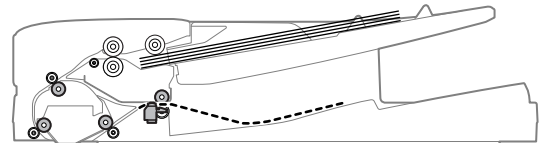

10) Paper exit start (2nd sheet)

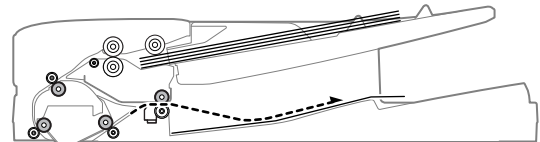

11) Paper exit complete (2nd sheet)

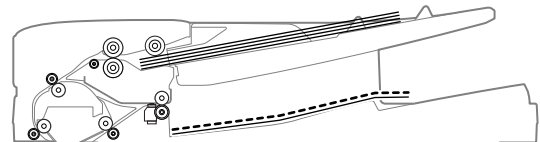

12) Pick-up roller lifting up  
(After completion of a job, the paper feed motor is rotated reversely at a low speed for a certain time to lift the pickup roller.)

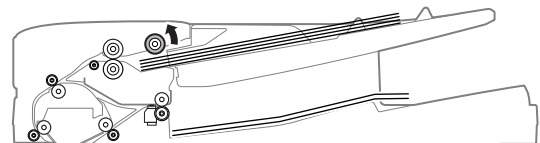

## 12. Fan and filter

The machine is provided with the following fan to discharge air from the process section and cool the fusing section and the power unit.

Signal name	Name	Function/Operation
FUFM	Fusing cooling fan	Prevents heat generated in the fusing section from flowing into the toner cartridge and the paper exit section.
POFM	Paper exit cooling fan	Cools the fusing section and the paper exit section.
POFM2	Paper exit cooling fan	Cools the fusing section and the paper exit section.
PROFM	Process fan motor 1	Blows air to the main charger and the PTC unit to promote discharging of ozone generated.
PROFM2	Process fan motor 2	Discharges ozone generated in the main charger and the PTC unit, and cools the developing unit.
PSFM	Power cooling fan motor	Cools the power unit.

The flow of air is as shown in the figure below.

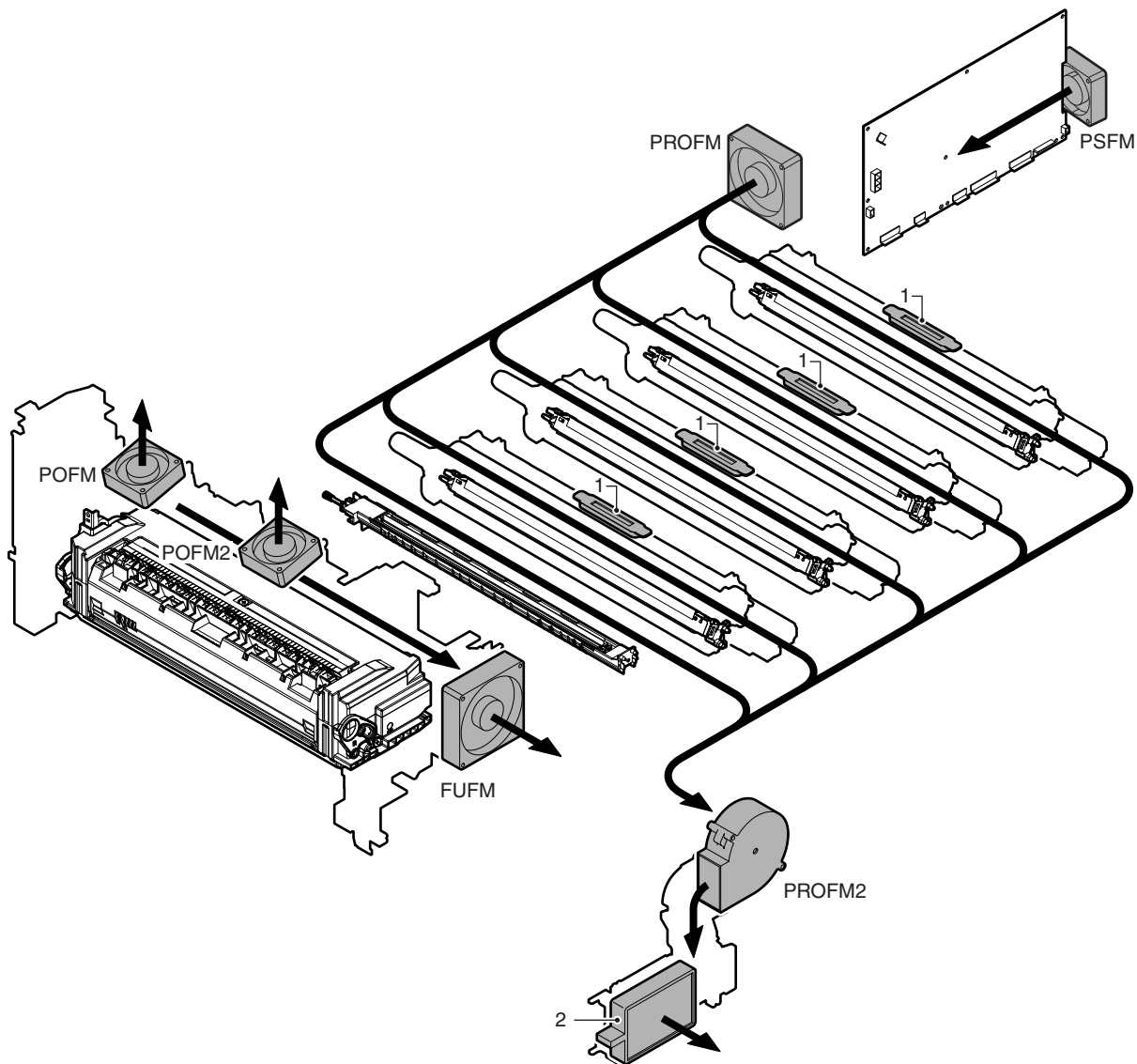

The machine is provided with the following filter to remove ozone generated in the process section.

Filter process fan motor 1 produces an air flow to generate a difference in the air pressure between inside outside of the developing unit, preventing toner from splashing from the open port of the developing unit.

The toner filter prevents toner from leaking from the slit caused by this difference in air pressure.

No.	Name	Function/Operation
1	Toner filter	Prevents toner splash.
2	Ozone filter	Absorbs ozone generated in the image process section.

## 13. Operations and specifications of counters

### A. Counters and count conditions

Condition	Counter						
	Print image	Total counter	User counter	Pixel count	Job log		
					Valid paper counter	Invalid paper counter	
Normal discharge paper	Valid image	Counted	Counted	Counted as a corresponding job.	Counted	Not counted	
Simplex surface white paper in the duplex job	White paper	Not counted	Not counted	Not counted	Not counted	Not counted	
White paper of cover paper, insert paper	White paper	Select with the setting of SIM26-52.	Select with the setting of SIM26-52.	Not counted	Select with the setting of SIM26-52.	Not counted	
Size illegal	Transfer completed	Valid image for some paper sizes	Counted	Counted	Counted as a corresponding job.	Counted	Not counted
	Transfer not completed	White paper	Not counted	Not counted	Not counted	Not counted	Counted
Document jam involvement in the RSPF pulling mode	White paper	Not counted	Not counted	Not counted	Not counted	Counted	
Anti copy	Paper for transfer OFF	Invalid image	Counted	Counted	Counted as a corresponding job.	Counted	Not counted
	Following paper	White paper	Not counted	Not counted	Not counted	Not counted	Counted
White paper at CA cancel	White paper	Not counted	Not counted	Not counted	Not counted	Counted	
Remaining paper at a paper jam	Not discharged	Not counted	Not counted	Counted as the other.	Not counted	Not counted	
Amount of print cancel for paper feed slip or paper empty	-	-	-	Counted as the other.	-	-	

### B. Maintenance system counters (Print counter)

Counter name	Count-up timing	Display SIM	Reset SIM	Count-up number					
				Simplex surface print		Duplex surface print			
				Paper feed tray - Paper exit completed		Paper feed tray - ADU paper entry completed		ADU paper feed - Paper exit completed	
				Small size	Large size	Small size	Large size	Small size	Large size
Maintenance counter (Total)	All paper exit operations completed	SIM22-13	SIM24-4	1	2(1)*1	1	2(1)*1	1	2(1)*1
Maintenance counter (Color)	Color paper exit operations completed			1	2(1)*1	1	2(1)*1	1	2(1)*1
Fusing belt print counter (Excluding the 18cpm/20cpm machine)	All paper exit operations completed	SIM22-13	SIM24-4	1	2(1)*1	1	2(1)*1	1	2(1)*1
Fusing roller print counter	All paper exit operations completed			1	2(1)*1	1	2(1)*1	1	2(1)*1
Pressure roller print counter	All paper exit operations completed			1	2(1)*1	1	2(1)*1	1	2(1)*1
Separation pawl print counter	All paper exit operations completed			1	2(1)*1	1	2(1)*1	1	2(1)*1
Separation plate print counter	All paper exit operations completed			1	2(1)*1	1	2(1)*1	1	2(1)*1
Cleaning roller print counter (Excluding the 36cpm machine)	All paper exit operations completed			1	2(1)*1	1	2(1)*1	1	2(1)*1
Fusing web print counter (36cpm machine)	All paper exit operations completed			1	2(1)*1	1	2(1)*1	1	2(1)*1
Primary transfer unit print counter	All paper exit operations completed			1	2(1)*1	1	2(1)*1	1	2(1)*1
Transfer blade print counter	All paper exit operations completed			1	2(1)*1	1	2(1)*1	1	2(1)*1
PTC print counter	All paper exit operations completed			1	2(1)*1	1	2(1)*1	1	2(1)*1
Secondary transfer unit print counter	All paper exit operations completed			1	2(1)*1	1	2(1)*1	1	2(1)*1
PS paper dust cleaner print counter	All paper exit operations completed			1	2(1)*1	1	2(1)*1	1	2(1)*1

Counter name	Count-up timing	Display SIM	Reset SIM	Count-up number					
				Simplex surface print		Duplex surface print			
				Paper feed tray - Paper exit completed		Paper feed tray - ADU paper entry completed		ADU paper feed - Paper exit completed	
				Small size	Large size	Small size	Large size	Small size	Large size
Developer cartridge print counter (K)	All paper exit operations completed	SIM22-13	SIM24-5 SIM25-2	1	2(1)*3	1	2(1)*3	1	2(1)*3
Developer cartridge print counter (C)	Color paper exit operations completed			1	2(1)*3	1	2(1)*3	1	2(1)*3
Developer cartridge print counter (M)	Color paper exit operations completed			1	2(1)*3	1	2(1)*3	1	2(1)*3
Developer cartridge print counter (Y)	Color paper exit operations completed			1	2(1)*3	1	2(1)*3	1	2(1)*3
Drum cartridge print counter (K)	All paper exit operations completed	SIM22-13	SIM24-4	1	2(1)*1	1	2(1)*1	1	2(1)*1
Drum cartridge print counter (C)	Color paper exit operations completed			1	2(1)*1	1	2(1)*1	1	2(1)*1
Drum cartridge print counter (M)	Color paper exit operations completed			1	2(1)*1	1	2(1)*1	1	2(1)*1
Drum cartridge print counter (Y)	Color paper exit operations completed			1	2(1)*1	1	2(1)*1	1	2(1)*1
Main charger print counter (K)	All paper exit operations completed			1	2(1)*1	1	2(1)*1	1	2(1)*1
Main charger print counter (C)	Color paper exit operations completed			1	2(1)*1	1	2(1)*1	1	2(1)*1
Main charger print counter (M)	Color paper exit operations completed			1	2(1)*1	1	2(1)*1	1	2(1)*1
Main charger print counter (Y)	Color paper exit operations completed			1	2(1)*1	1	2(1)*1	1	2(1)*1
Drum blade print counter (K)	All paper exit operations completed			1	2(1)*1	1	2(1)*1	1	2(1)*1
Drum blade print counter (C)	Color paper exit operations completed			1	2(1)*1	1	2(1)*1	1	2(1)*1
Drum blade print counter (M)	Color paper exit operations completed			1	2(1)*1	1	2(1)*1	1	2(1)*1
Drum blade print counter (Y)	Color paper exit operations completed			1	2(1)*1	1	2(1)*1	1	2(1)*1
Ozone filter print counter	All paper exit operations completed			1	2(1)*1	1	2(1)*1	1	2(1)*1
Toner cartridge print counter (K)	All paper exit operations completed			SIM22-13	-	1	2(1)*4	1	2(1)*4
Toner cartridge print counter (C)	Color paper exit operations completed	1	2(1)*4			1	2(1)*4	1	2(1)*4
Toner cartridge print counter (M)	Color paper exit operations completed	1	2(1)*4			1	2(1)*4	1	2(1)*4
Toner cartridge print counter (Y)	Color paper exit operations completed	1	2(1)*4			1	2(1)*4	1	2(1)*4

\*1: The number in ( ) is the count-up number when the large-size count-up setting is changed to the single count-up with SIM26-5 (Maintenance count (B/W, COL)).

\*3: The number in ( ) is the count-up number when the large-size count-up setting is changed to the single count-up with SIM26-5 (Developer count (B/W, COL)).

\*4: The number in ( ) is the count-up number when the large-size count-up setting is changed to the single count-up with SIM26-5 (Total count (B/W, COL)).

### C. Maintenance system counters (Number of rotations)

Counter name	Count-up timing	Display SIM	Reset SIM	Count-up number													
				Simplex surface print		Duplex surface print											
				Paper feed tray - Paper exit completed		Paper feed tray - ADU paper entry completed		ADU paper feed - Paper exit completed									
				Small size	Large size	Small size	Large size	Small size	Large size								
Fusing belt accumulated rotation time (Excluding the 18cpm/20cpm machine)	While the fusing motor is driven.	SIM22-13	SIM24-4	RPM (Unit: 1) * Calculated from the traveling distance.													
Fusing roller accumulated rotation time	While the fusing motor is driven.																
Pressure roller accumulated rotation time	While the fusing motor is driven.																
Separation pawl accumulated rotation time	While the fusing motor is driven.																
Separation plate accumulated rotation time	While the fusing motor is driven.																
Cleaning roller rotation time (Excluding the 36cpm machine)	While the fusing motor is driven.																
Primary transfer unit accumulated rotation time	While the primary transfer unit is driven.																
Transfer blade accumulated rotation time	While the drum (K) is driven.																
PTC accumulated rotation time	While the drum (K) is driven.																
Secondary transfer unit accumulated rotation time	While the secondary transfer unit is driven.																
Developer cartridge accumulated rotation time (K)	While the drum (K) is driven.	SIM22-13	SIM24-5 SIM25-2														
Developer cartridge accumulated rotation time (C)	While the drum (C) is driven.																
Developer cartridge accumulated rotation time (M)	While the drum (M) is driven.																
Developer cartridge accumulated rotation time (Y)	While the drum (Y) is driven.																
Drum cartridge accumulated rotation time (K)	While the drum (K) is driven.	SIM22-13	SIM24-4														
Drum cartridge accumulated rotation time (C)	While the drum (C) is driven.																
Drum cartridge accumulated rotation time (M)	While the drum (M) is driven.																
Drum cartridge accumulated rotation time (Y)	While the drum (Y) is driven.																
Main charger accumulated rotation time (K)	While the drum (K) is driven.																
Main charger accumulated rotation time (C)	While the drum (C) is driven.																
Main charger accumulated rotation time (M)	While the drum (M) is driven.																
Main charger accumulated rotation time (Y)	While the drum (Y) is driven.																
Drum blade accumulated rotation time (K)	While the drum (K) is driven.																
Drum blade accumulated rotation time (C)	While the drum (C) is driven.																
Drum blade accumulated rotation time (M)	While the drum (M) is driven.																
Drum blade accumulated rotation time (Y)	While the drum (Y) is driven.																
Toner motor accumulated rotation time (K)	While the toner motor (K) is driven.									SIM22-13	-	RPM (Unit: 1) * Calculated from the rotating time.					
Toner motor accumulated rotation time (C)	While the toner motor (C) is driven.																
Toner motor accumulated rotation time (M)	While the toner motor (M) is driven.																
Toner motor accumulated rotation time (Y)	While the toner motor (Y) is driven.																

#### D. Maintenance system counters (Number of use days)

Counter name	Count-up timing	Display SIM	Reset SIM	Count-up number														
				Simplex surface print		Duplex surface print												
				Paper feed tray - Paper exit completed		Paper feed tray - ADU paper entry completed		ADU paper feed - Paper exit completed										
				Small size	Large size	Small size	Large size	Small size	Large size									
Number of day that used maintenance counter (Total)	Date change	SIM22-13	SIM24-4	1 (Unit: day)														
Number of day that used maintenance counter (Color)																		
Number of day that used fusing belt (Excluding the 18cpm/20cpm machine)	Date change	SIM22-13	SIM24-4															
Number of day that used fusing roller																		
Number of day that used pressure roller																		
Number of day that used separation pawl																		
Number of day that used separation plate																		
Number of day that used cleaning roller (Excluding the 36cpm machine)																		
Number of day that used fusing web (36cpm machine)																		
Number of day that used primary transfer unit																		
Number of day that used transfer blade																		
Number of day that used PTC																		
Number of day that used secondary transfer unit																		
Number of day that used PS paper dust cleaner																		
Number of day that used developer cartridge (K)																		
Number of day that used developer cartridge (C)																		
Number of day that used developer cartridge (M)	Date change	SIM22-13	SIM24-5 SIM25-2															
Number of day that used developer cartridge (Y)																		
Number of day that used drum cartridge (K)																		
Number of day that used drum cartridge (C)																		
Number of day that used drum cartridge (M)	Date change	SIM22-13	SIM24-4															
Number of day that used drum cartridge (Y)																		
Number of day that used main charger (K)																		
Number of day that used main charger (C)																		
Number of day that used main charger (M)																		
Number of day that used main charger (Y)																		
Number of day that used drum blade (K)																		
Number of day that used drum blade (C)																		
Number of day that used drum blade (M)																		
Number of day that used drum blade (Y)																		
Number of day that used ozone filter																		
Number of day that used toner cartridge (K)										Date change	SIM22-13	-						
Number of day that used toner cartridge (C)																		
Number of day that used toner cartridge (M)																		
Number of day that used toner cartridge (Y)																		

## E. Maintenance system counters (Other)

Counter name	Count-up timing	Display SIM	Reset SIM	Count-up number					
				Simplex surface print		Duplex surface print			
				Paper feed tray - Paper exit completed		Paper feed tray - ADU paper entry completed		ADU paper feed - Paper exit completed	
				Small size	Large size	Small size	Large size	Small size	Large size
Staple counter	When requesting for staple	SIM22-8	SIM24-3	Number of staples					
Saddle staple counter (26cpm/36cpm/31cpm(A) machine)									
Saddle finisher V fold counter (26cpm/36cpm/31cpm(A) machine)									
Punch counter	When requesting for punch	SIM22-9	SIM24-2	1					
Manual paper feed counter (Total)	When manual paper feed is started			1					
Manual paper feed counter (Heavy paper)	When manual paper feed of heavy paper is started (without distinction between heavy paper 1 and 2)								
Manual paper feed counter (OHP)	When manual paper feed of OHP sheet is started								
Manual paper feed counter (Envelope)	When manual paper feed of envelopes is started								
Tray 1 counter	When tray 1 paper feed is started								
Tray 2 counter	When tray 2 paper feed is started (request)								
Tray 3 counter	When tray 3 paper feed is started (request)								
Tray 4 counter	When tray 4 paper feed is started (request)								
LCC counter	When LCC paper feed is started (request)								
ADU counter	When ADU paper feed is started			SIM22-9	SIM24-2	1			
Fusing web cleaning feed counter (36cpm machine only)	When the fusing web cleaning roller is rotated	SIM22-13	SIM24-4	Number of pulses					
Toner use number counter (K)	When toner near end is detected (*2)	SIM22-14	SIM24-35	1					
Toner use number counter (C)									
Toner use number counter (M)									
Toner use number counter (Y)									
Toner near end number counter (K)									
Toner near end number counter (C)	When toner near end is detection								
Toner near end number counter (M)									
Toner near end number counter (Y)									

## F. RSPF/Scanner counter

Counter name	Display SIM	Reset SIM	Count-up timing	NOTE
RSPF counter	SIM22-8	SIM24-3	When SPF document discharge is completed. The front surface in duplex scan is counted when the reverse operation is stopped.	Number of discharge of document from the SPF
Scan counter	SIM22-8	SIM24-3	When the scanner carriage feed is completed.	Number of times of scan
Finish stamp counter	SIM22-8	SIM24-3	When the stamp is ON.	Number of use of the finish stamp
Cover open/close counter	SIM22-8	SIM24-3	When the document cover close is detected.	Number of open/close of the cover
Home detection counter	SIM22-8	SIM24-3	When the home sensor ON is detected.	Number of detection of the home position
Scanner lamp lighting time counter	SIM22-8	SIM24-3	When the scanner lamp is lighted.	Scanner lamp lighting time





(2) 20cpm machine

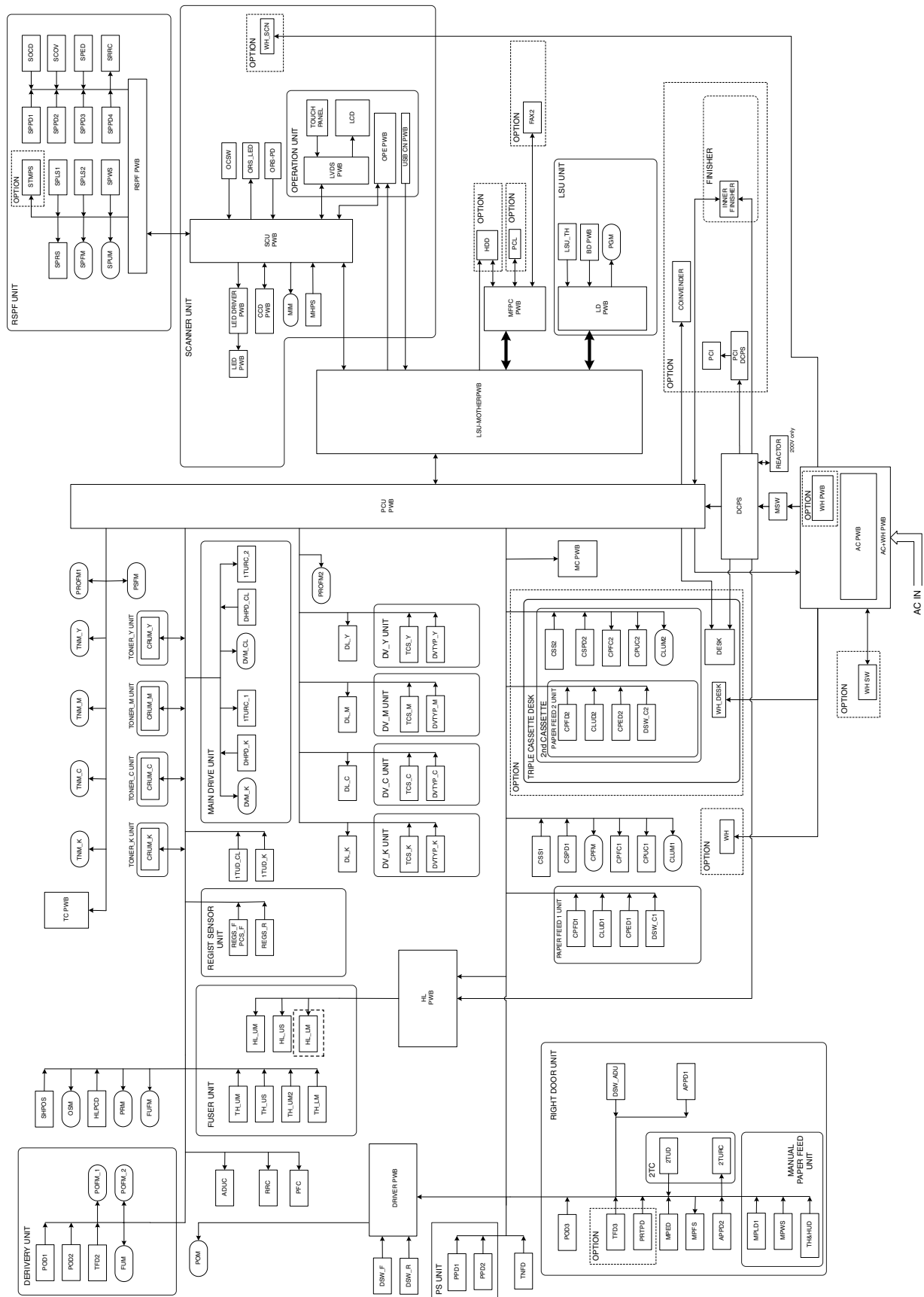

(3) 23cpm machine

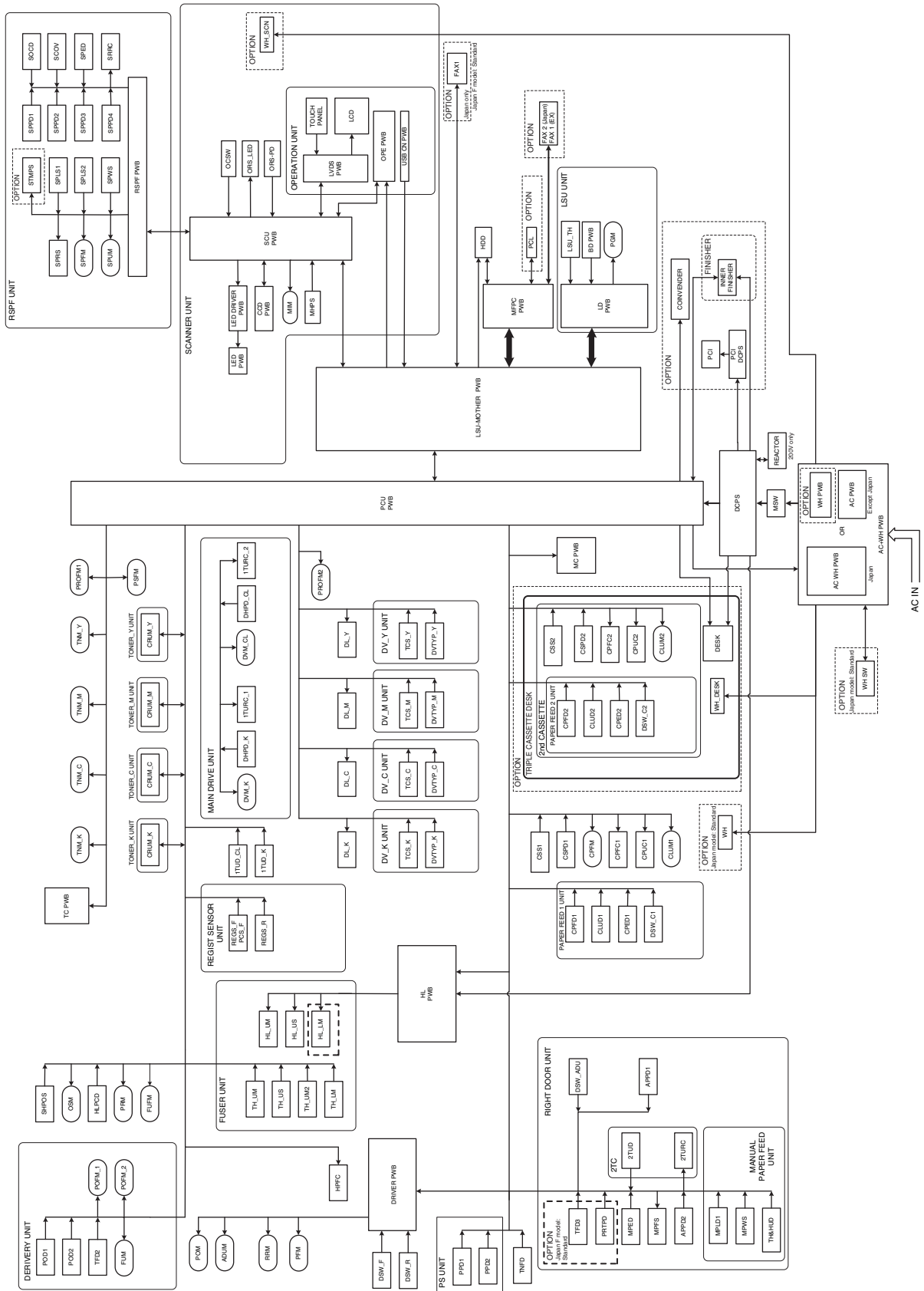





## B. PCU PWB

### (1) 18cpm/20cpm machine

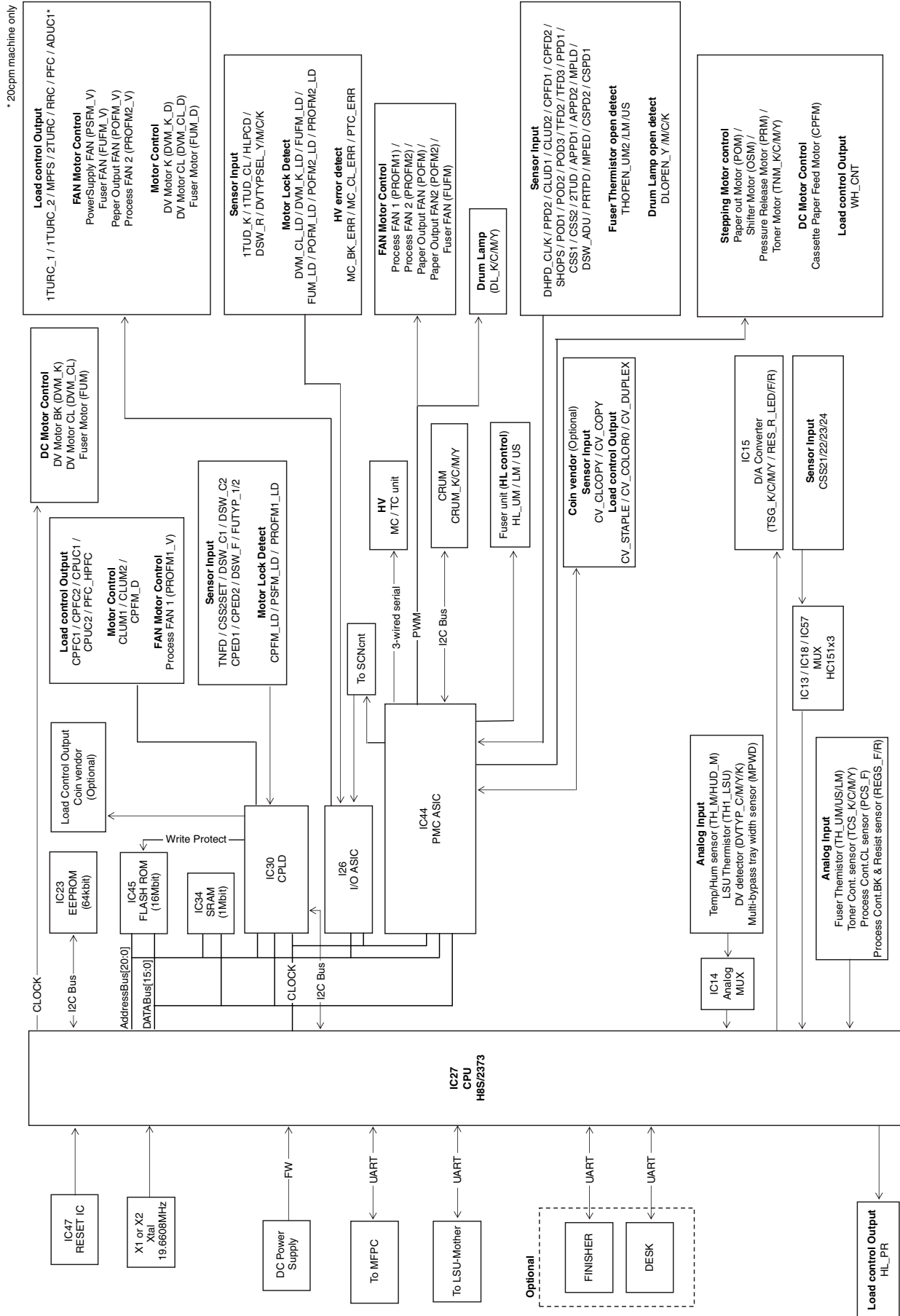







(4) 26cpm/36cpm/31cpm(A) machine

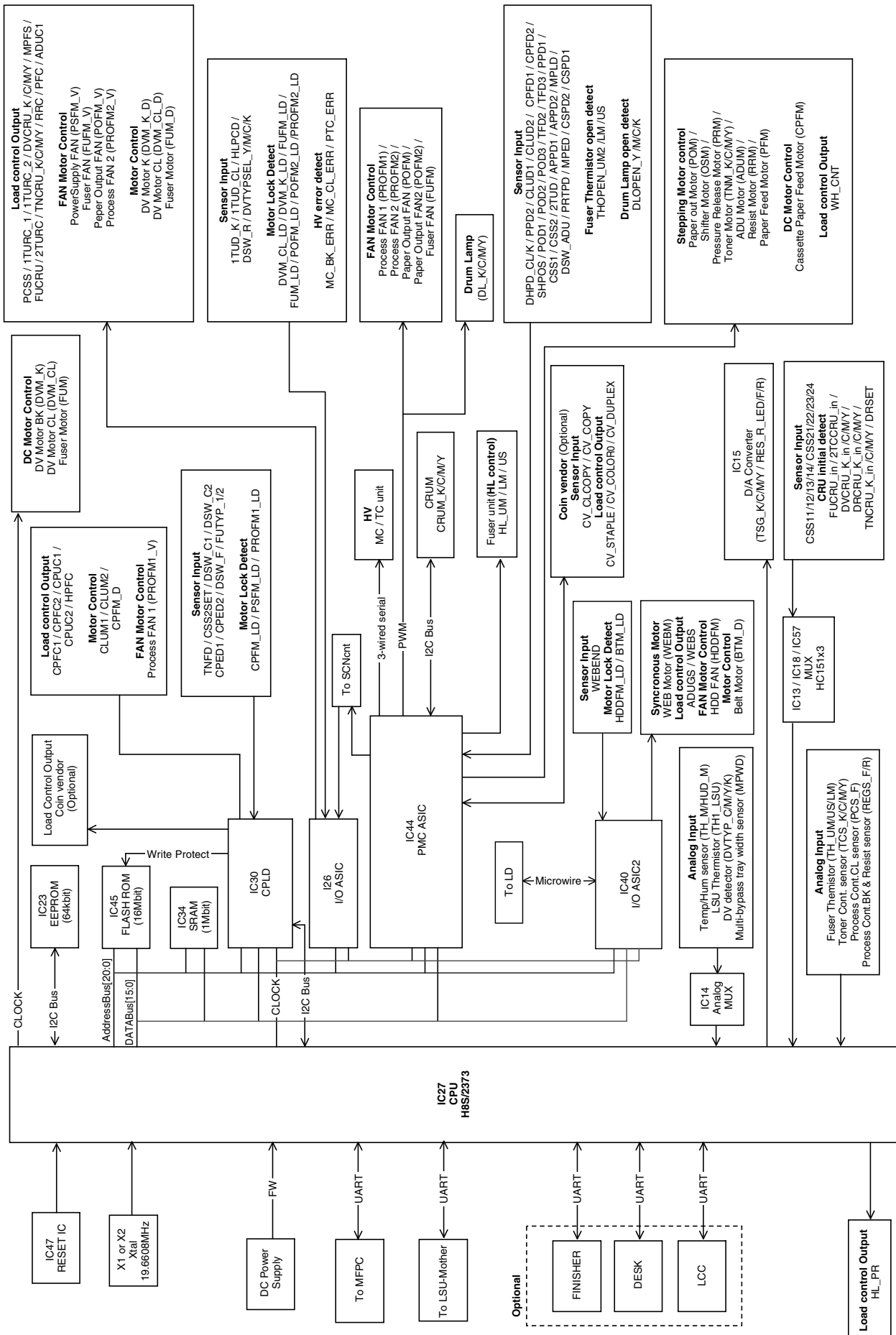

C. MFP control PWB

(1) 18cpm machine

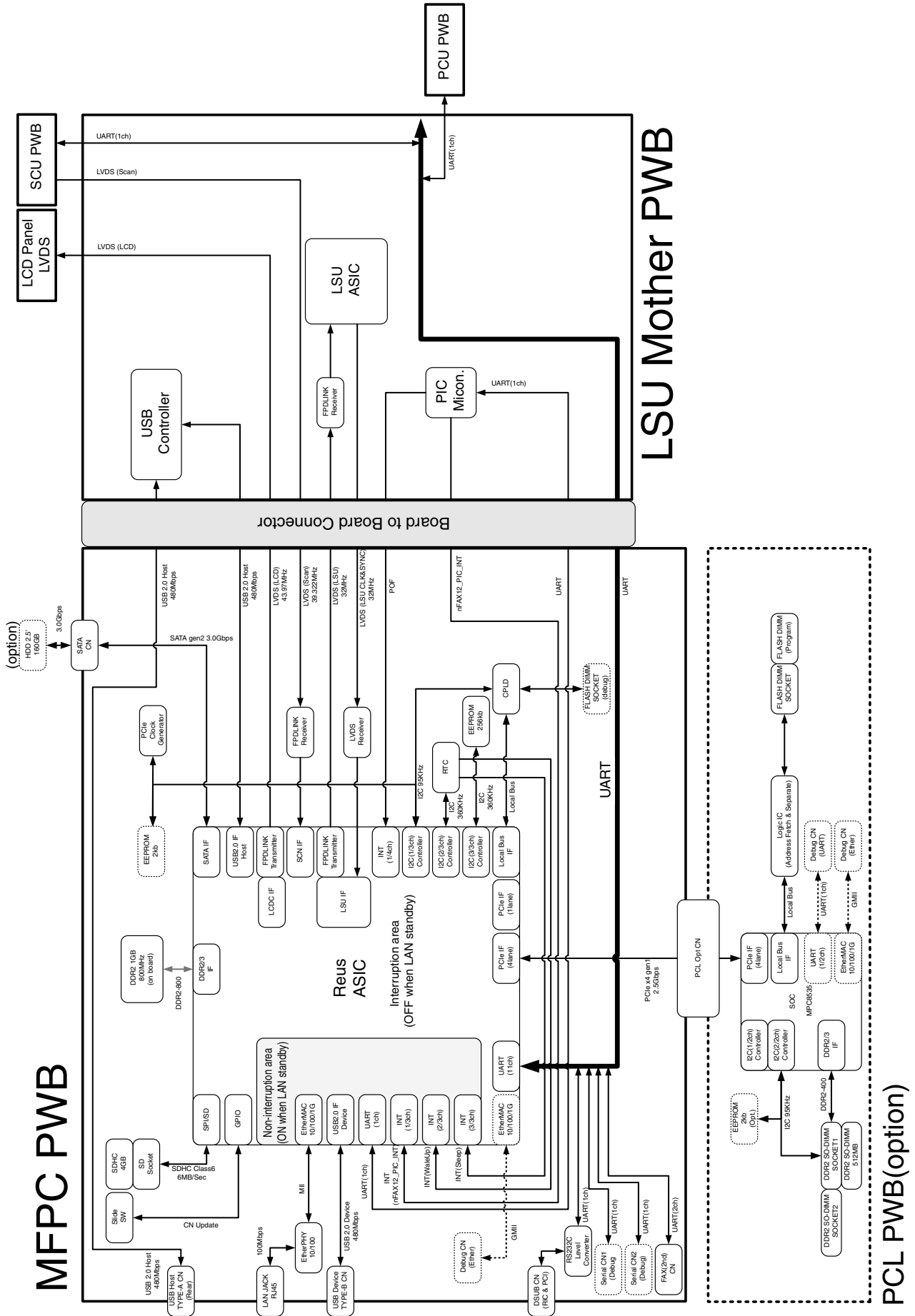

(2) 20cpm/23cpm/31cpm(G) machine

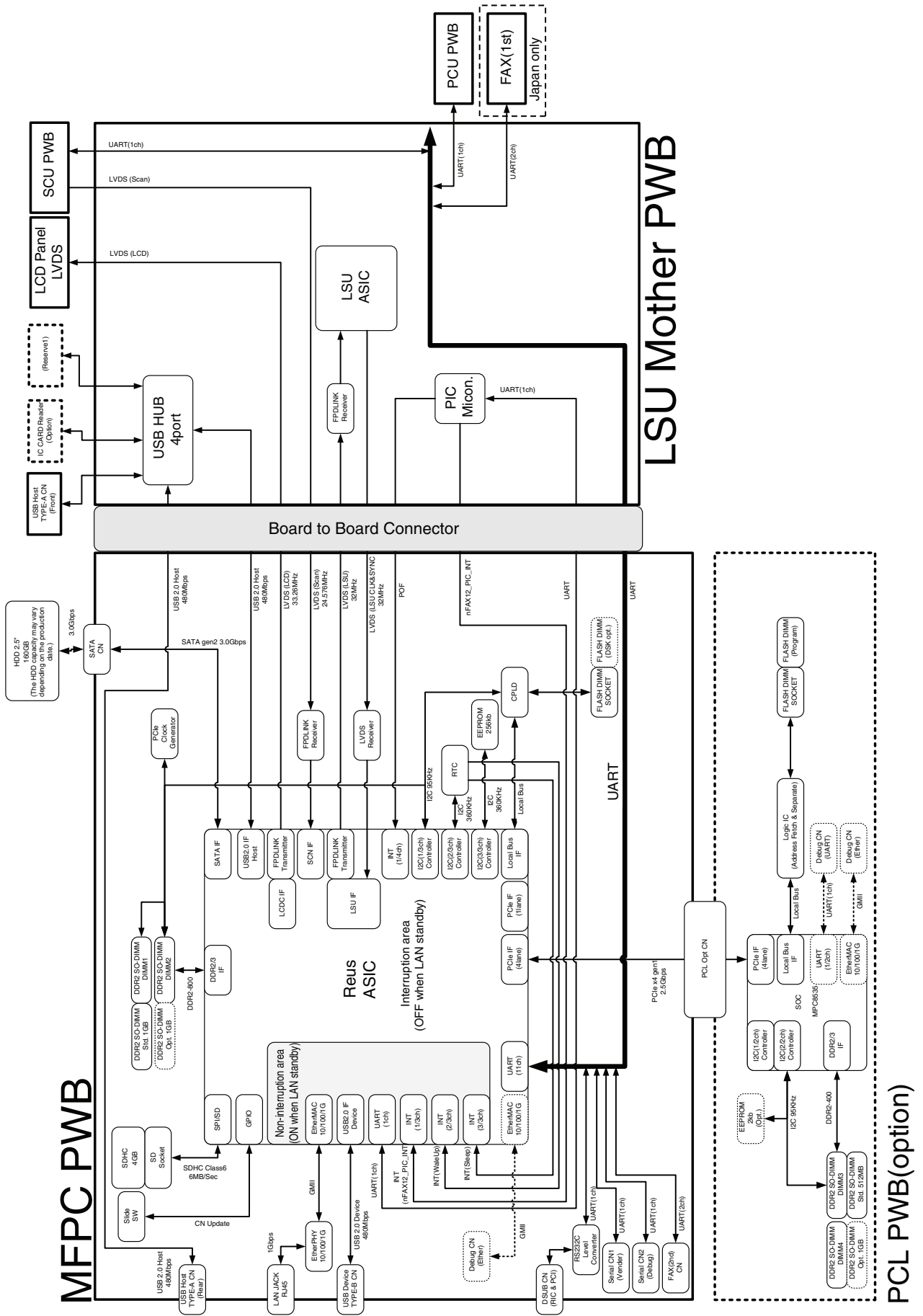

(3) 26cpm/36cpm/31cpm(A) machine

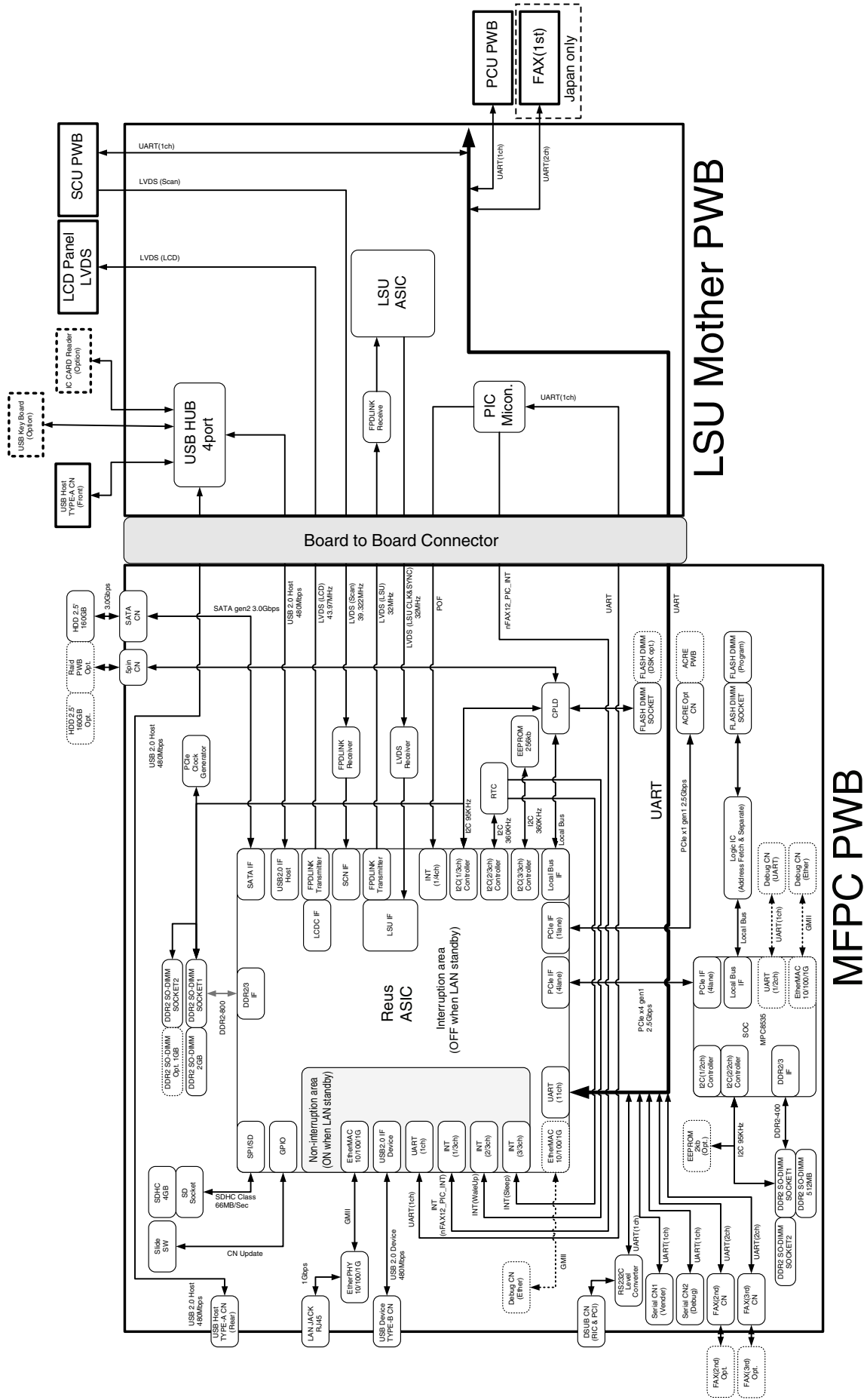

# D. Scanner control PWB

## (1) 18cpm machine

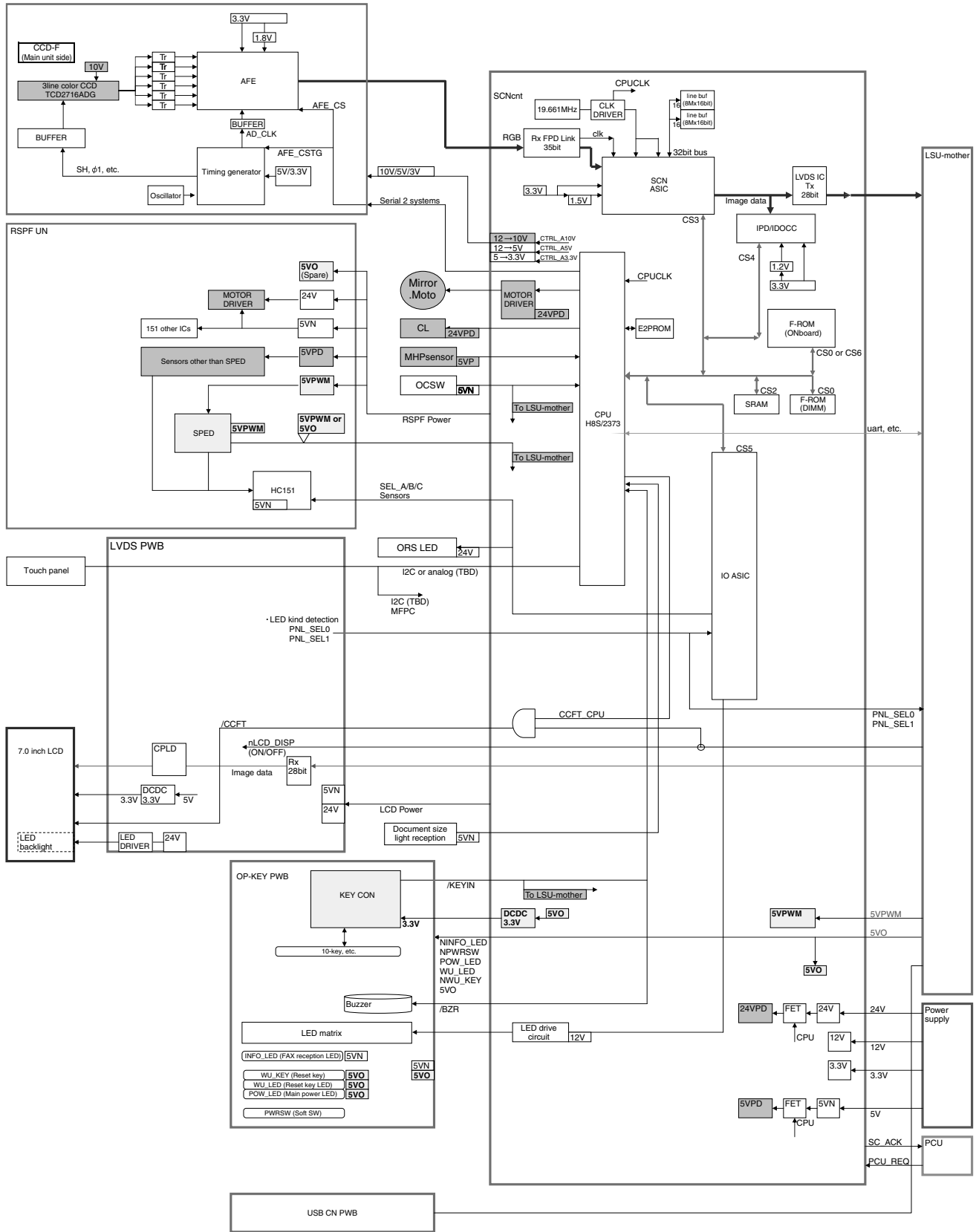

(2) 20cpm/23cpm/31cpm(G) machine

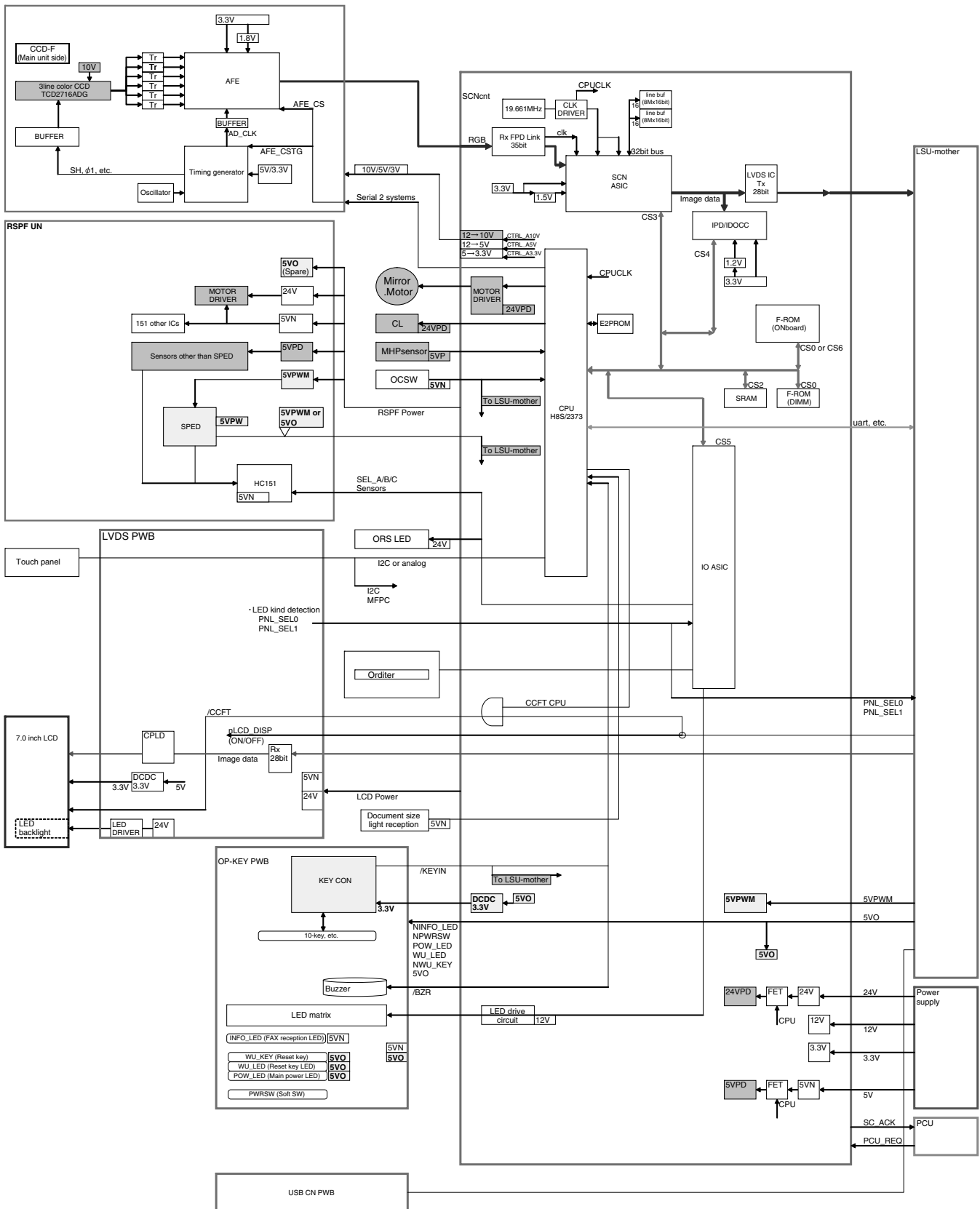

**(3) 26cpm/36cpm/31cpm(A) machine**

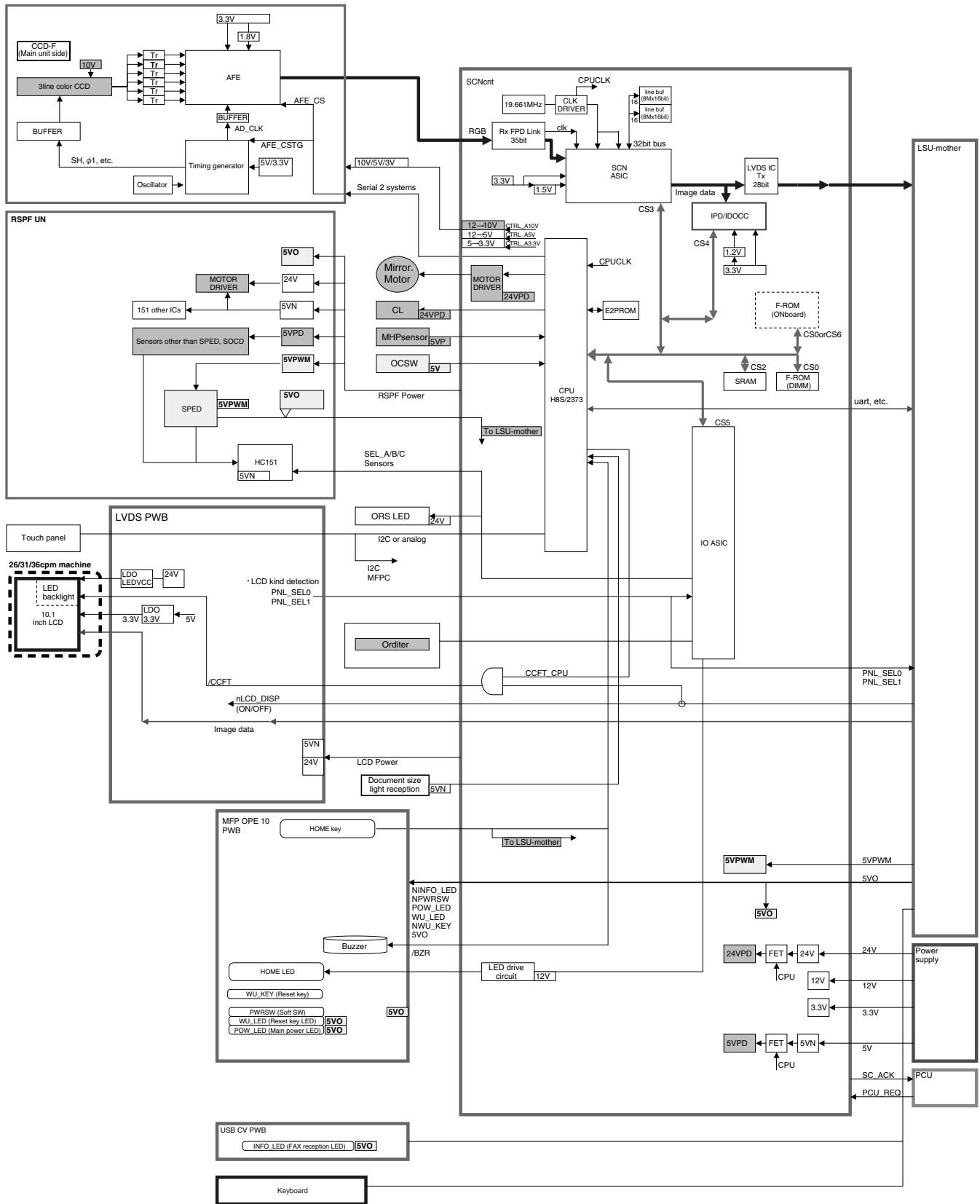

**E. Operation unit**  
**(1) 18cpm machine**

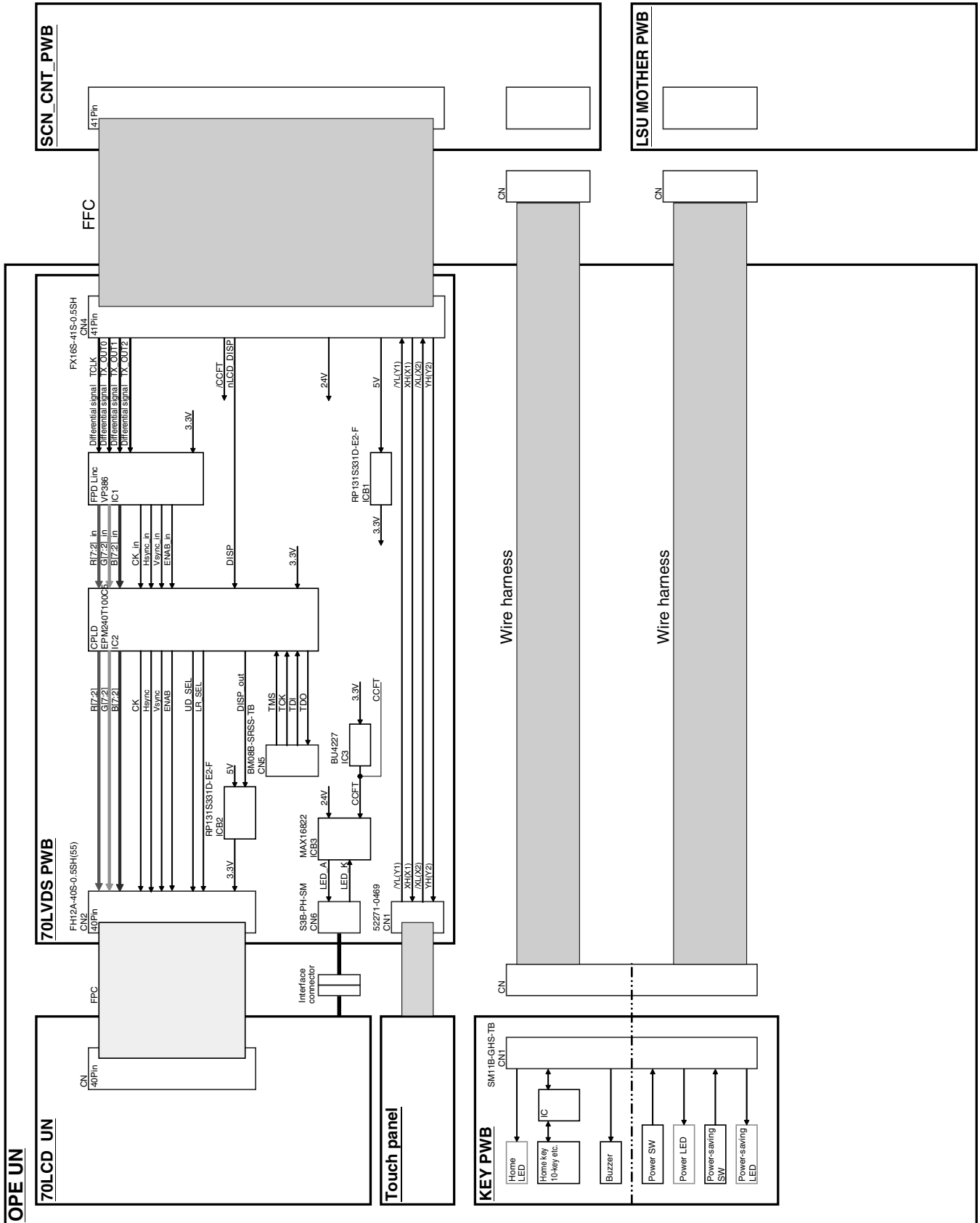



(2) 20cpm/23cpm/31cpm(G) machine

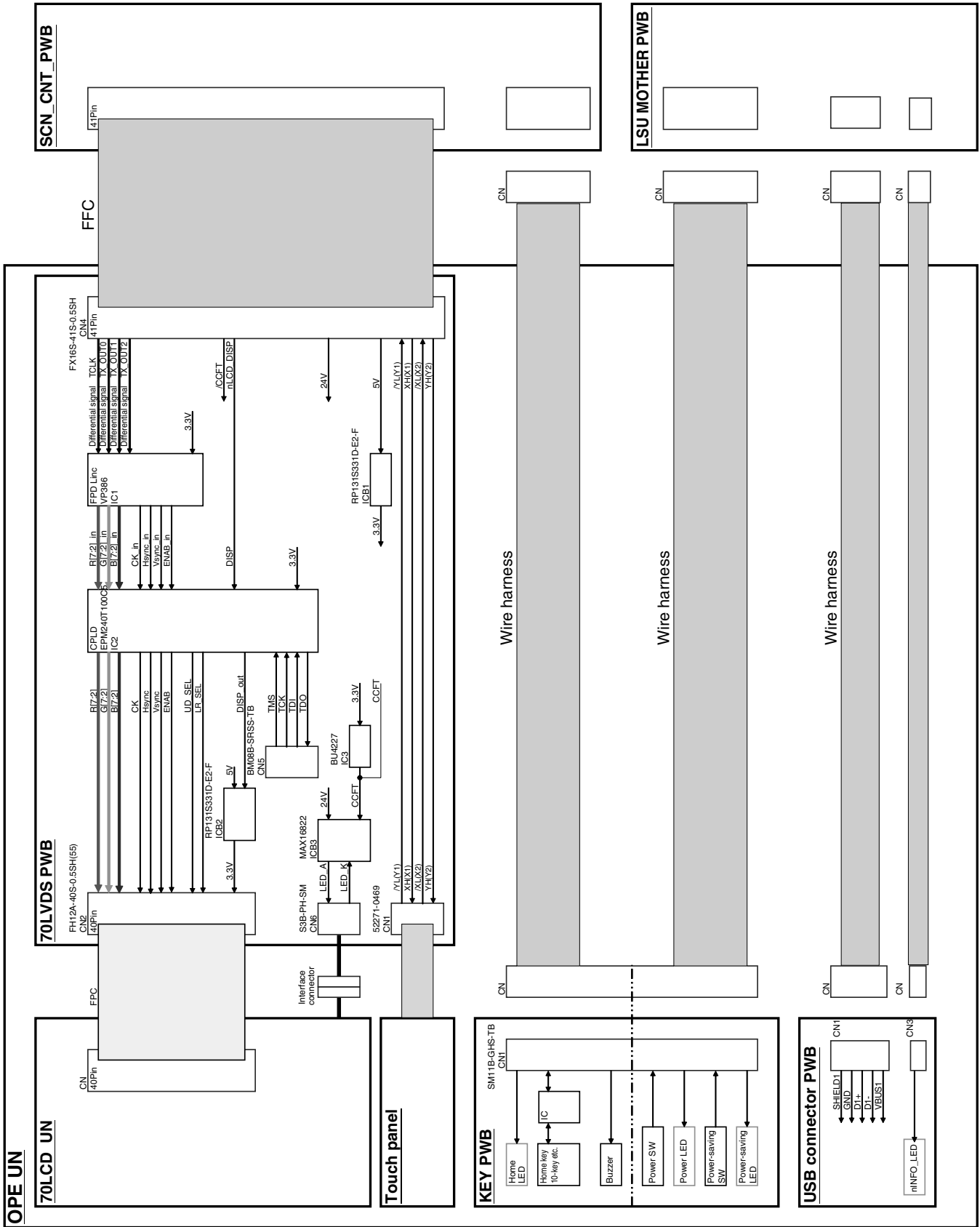

(3) 26cpm/36cpm/31cpm(A) machine

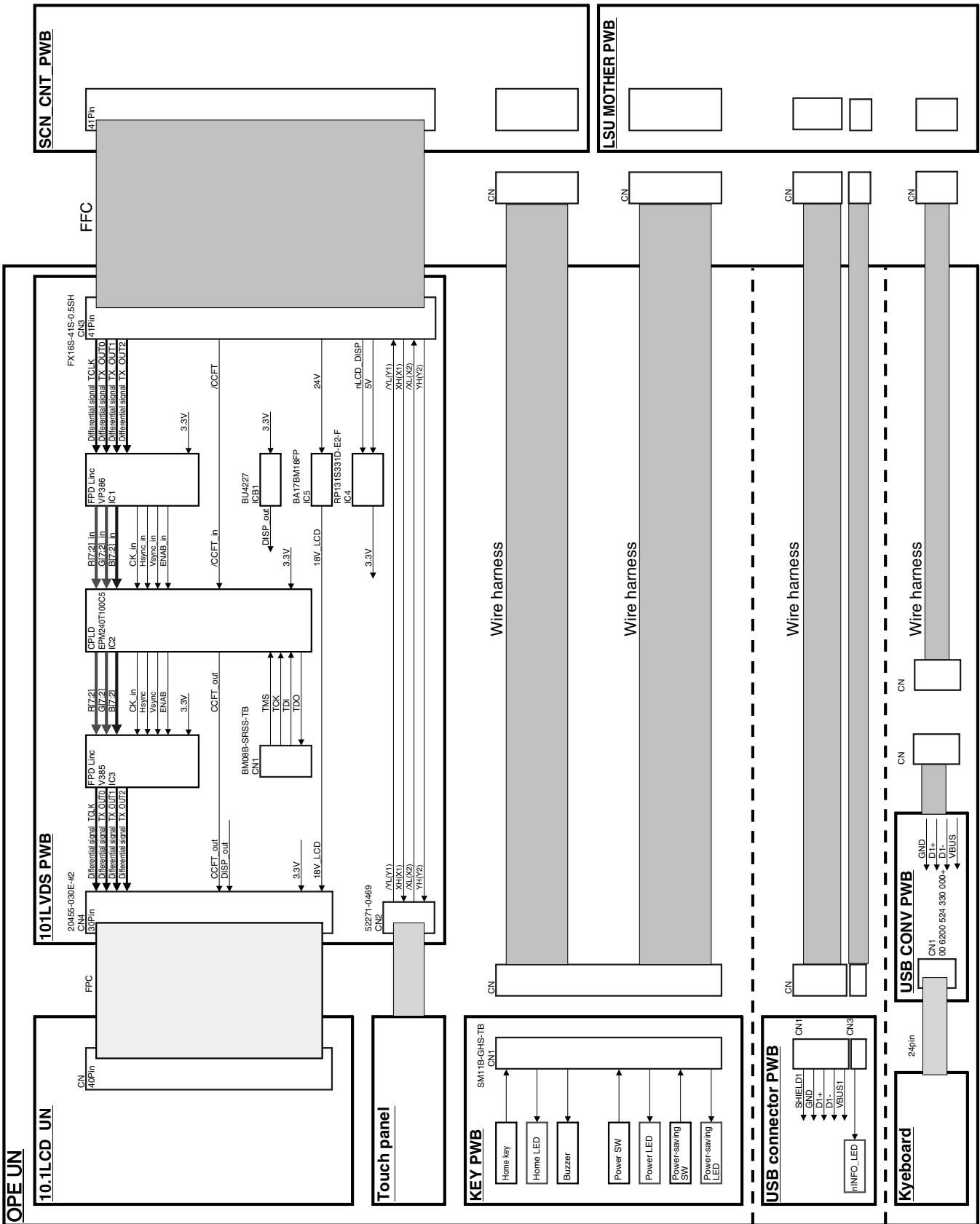

## F. LSU-mother PWB

### (1) 18cpm/20cpm/23cpm/31cpm(G) machine

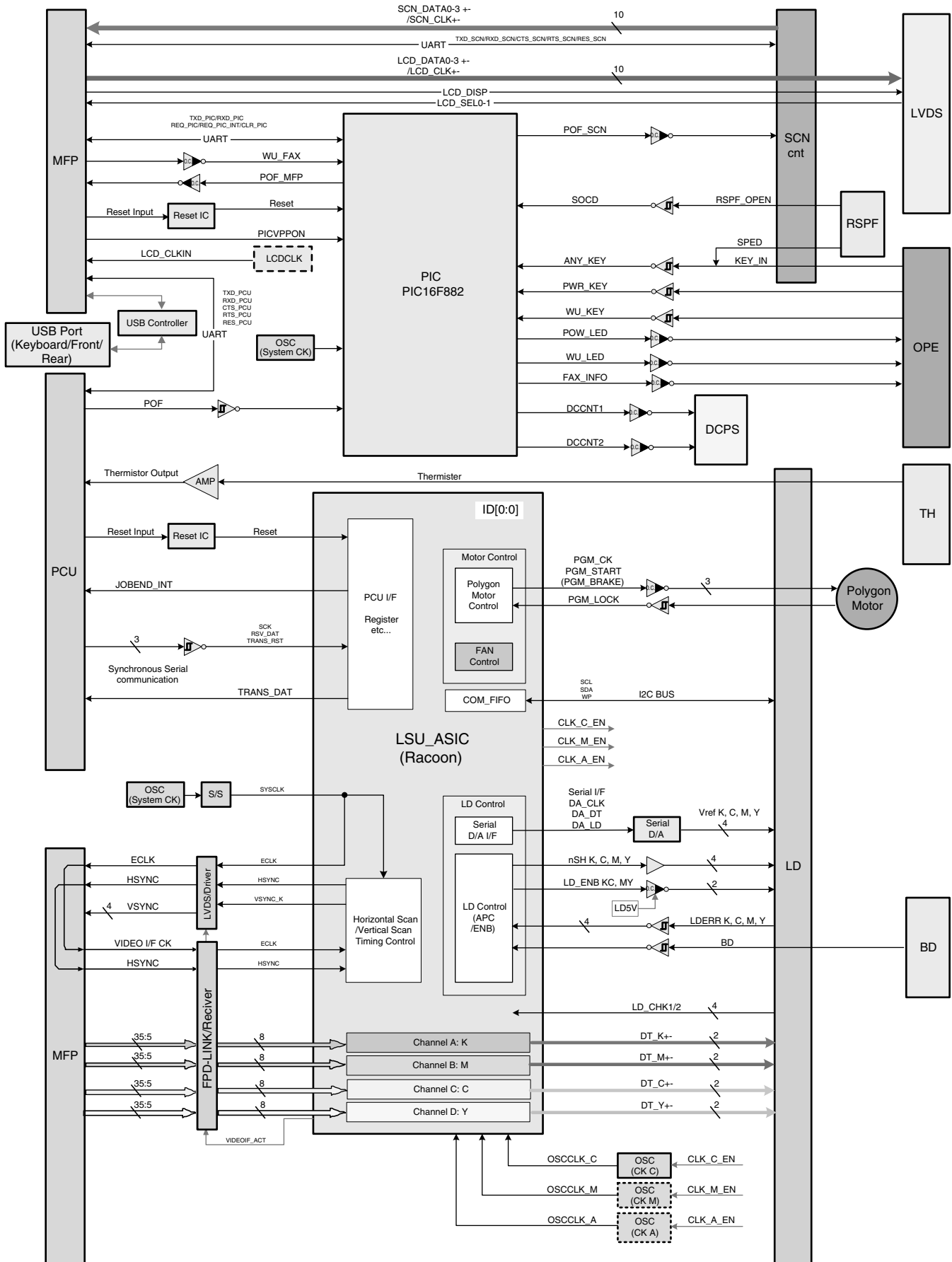

(2) 26cpm/36cpm/31cpm(A) machine

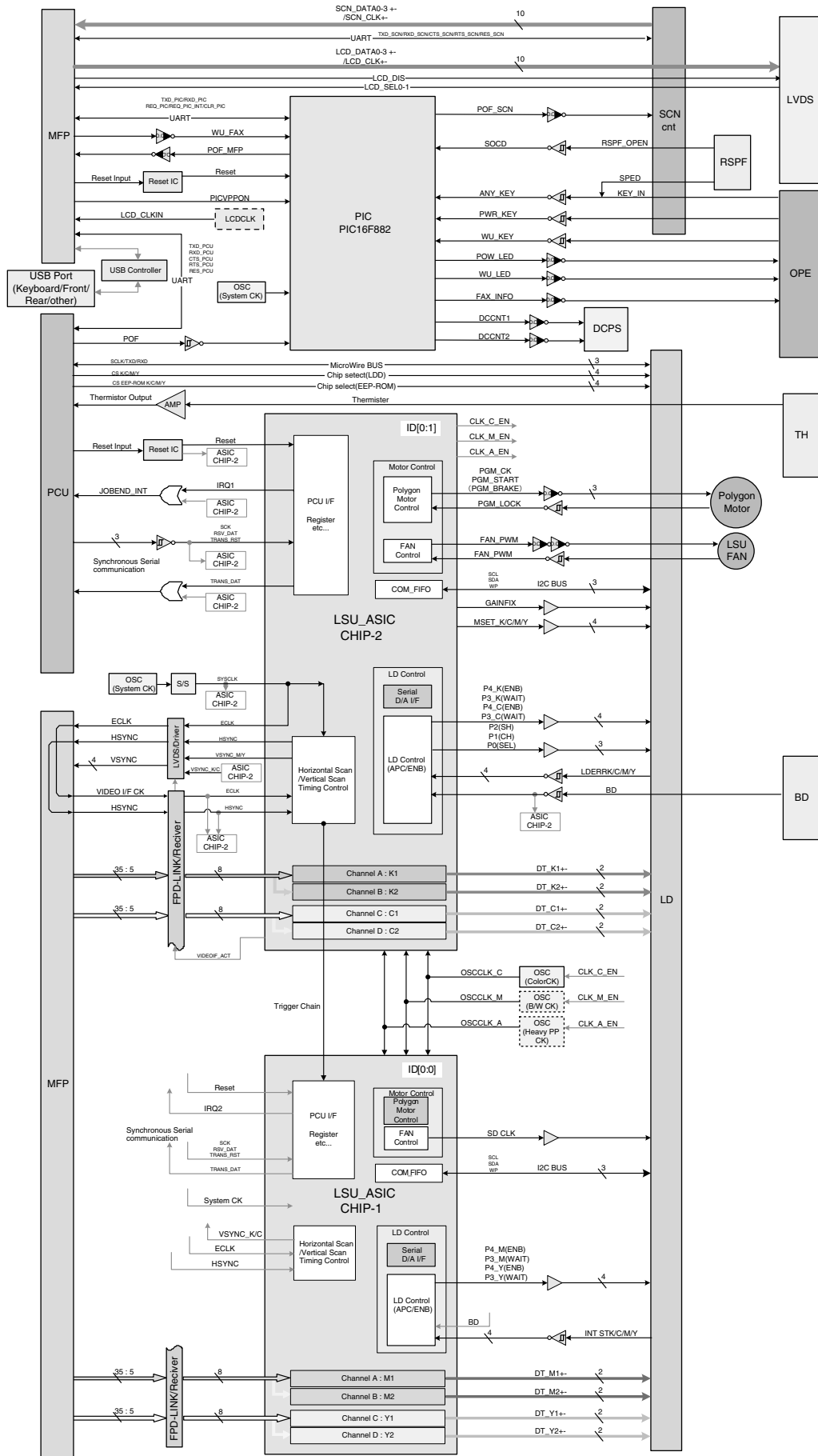

# G. FAX section

## (1) MX-FX11

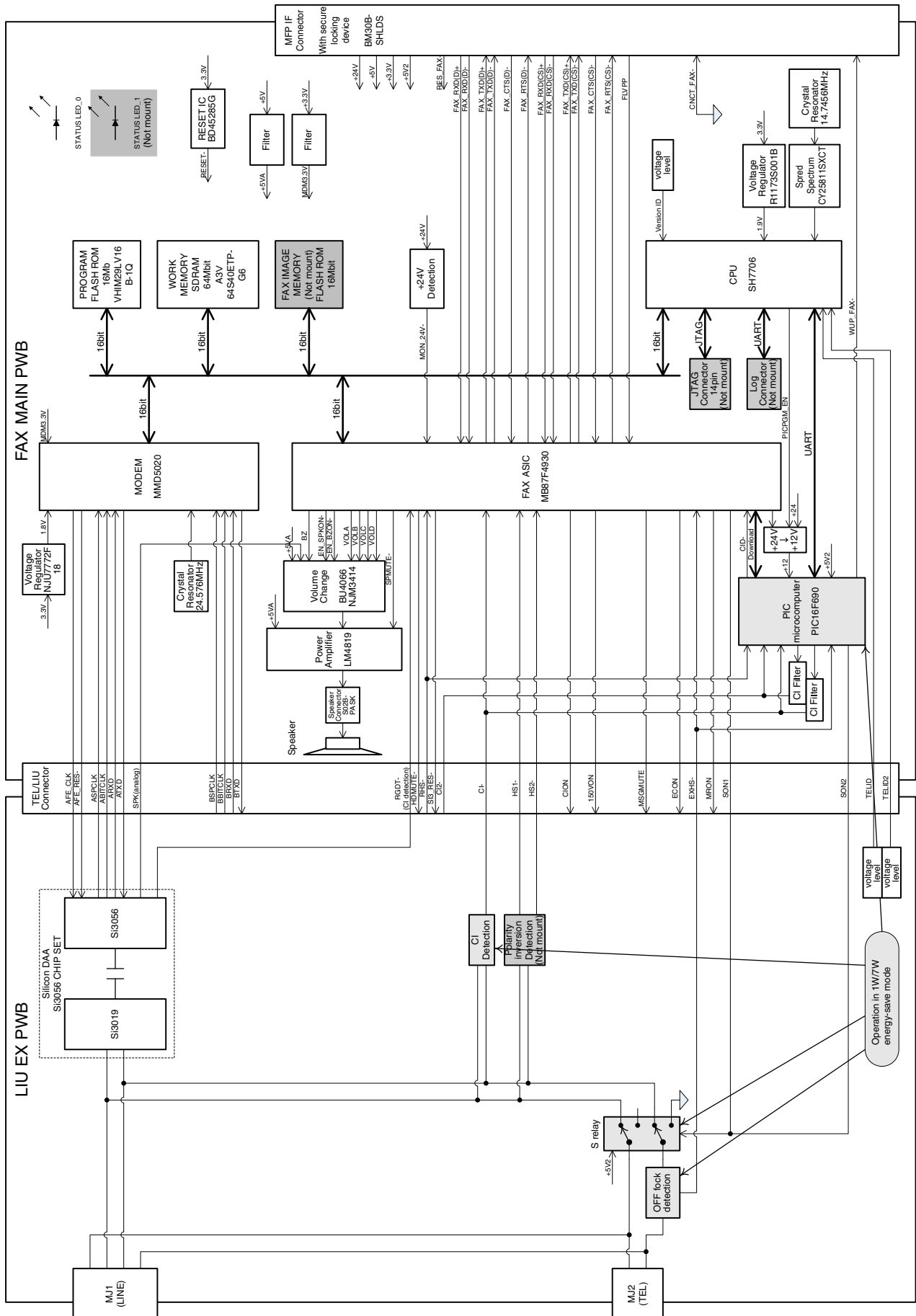

# H. SERIAL COMMUNICATION

## (1) 18cpm/20cpm machine

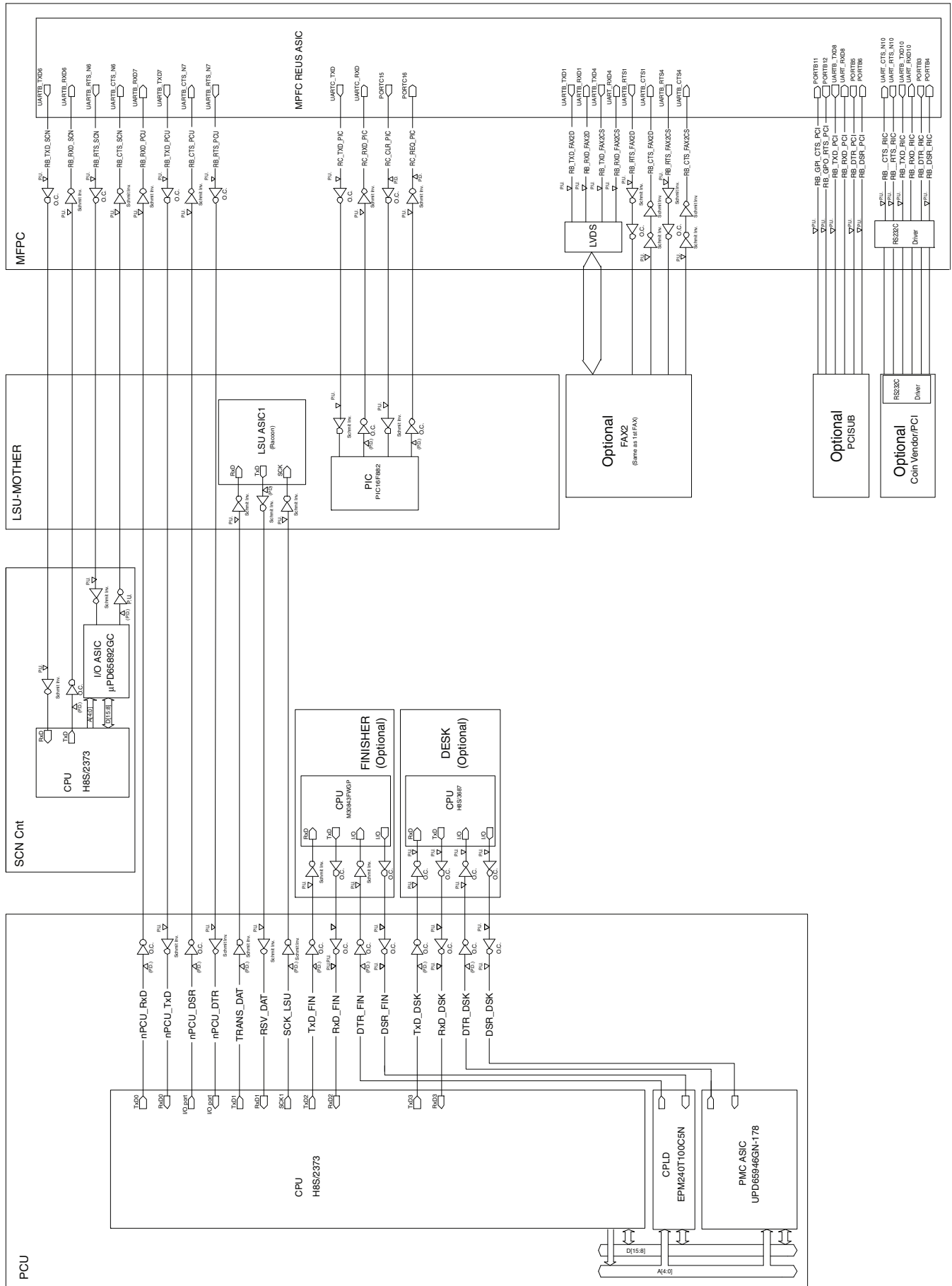

(2) 23cpm/31cpm(G) machine

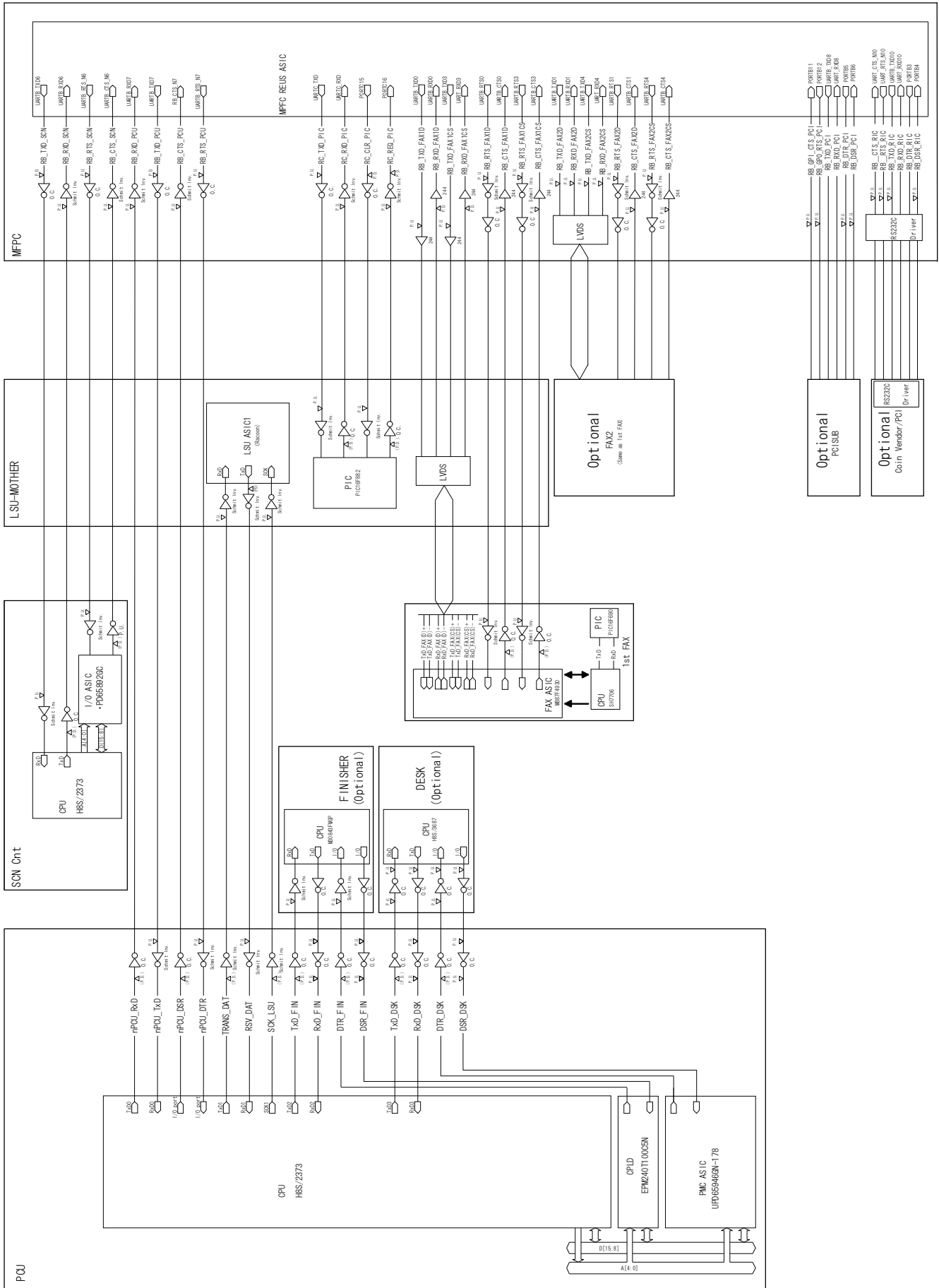

(3) 26cpm/36cpm/31cpm(A) machine

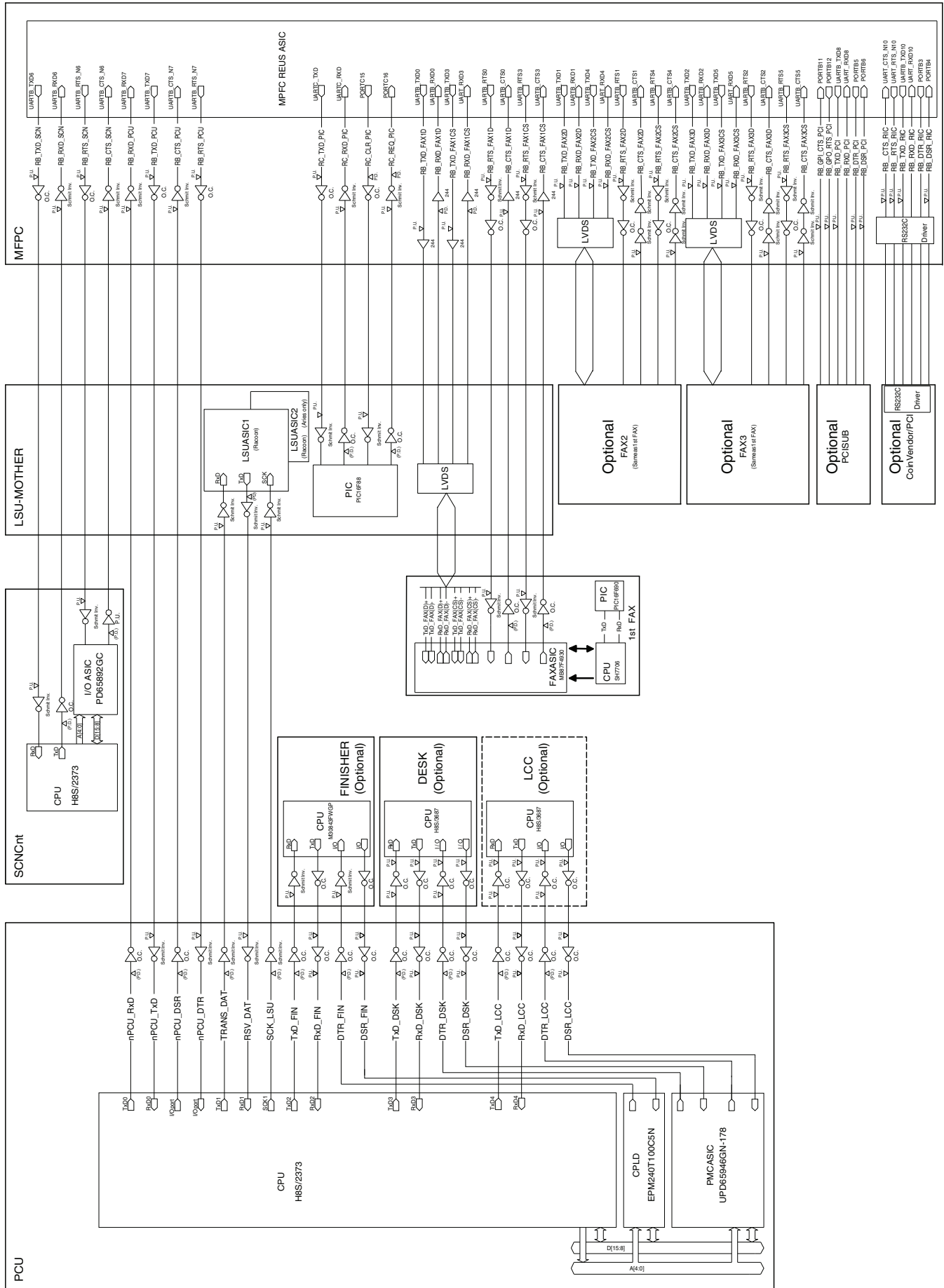



# I. FAX (Option)

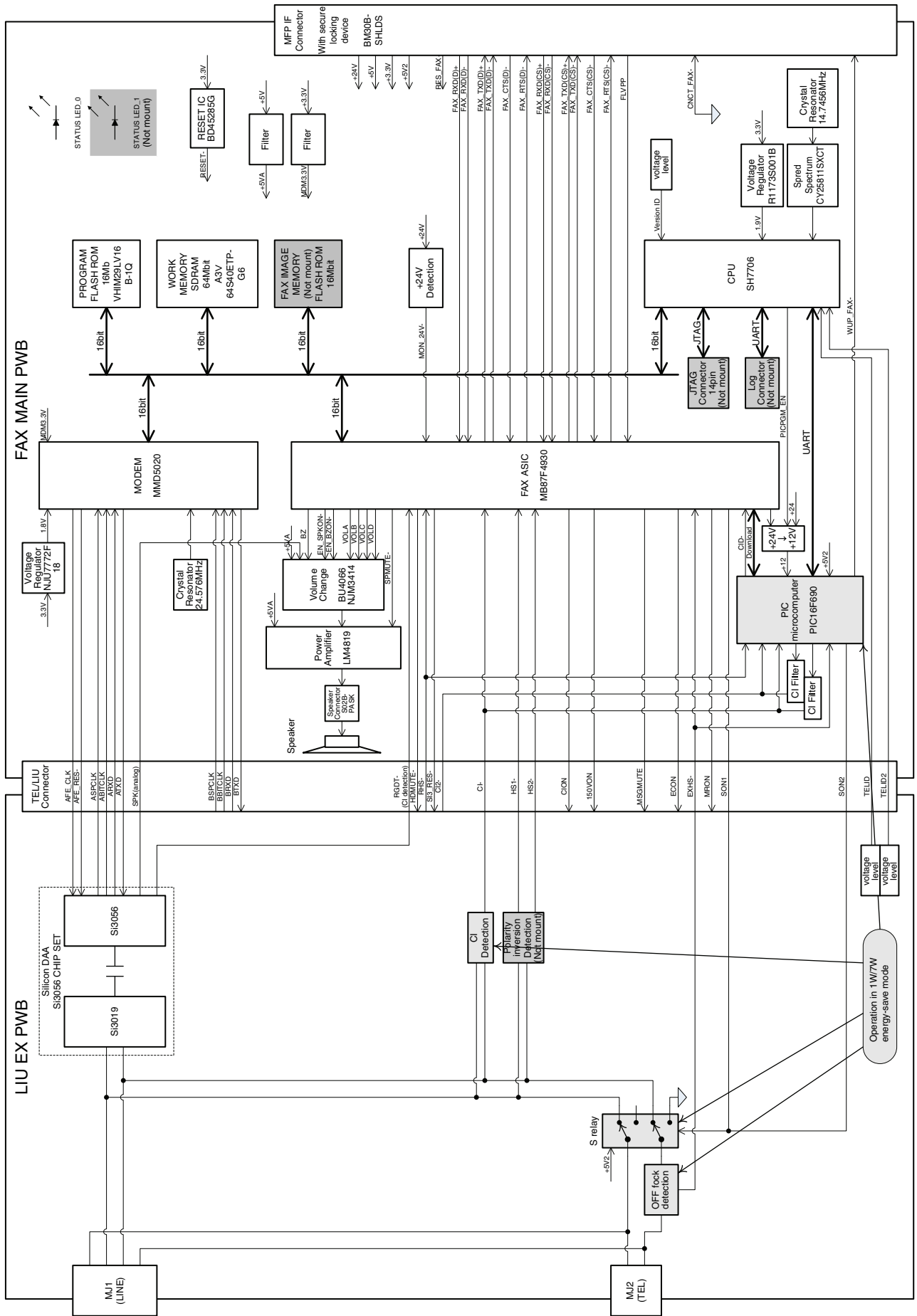

## 2. Power line diagram

### A. AC power line diagram

#### (1) AC power line diagram (120V)

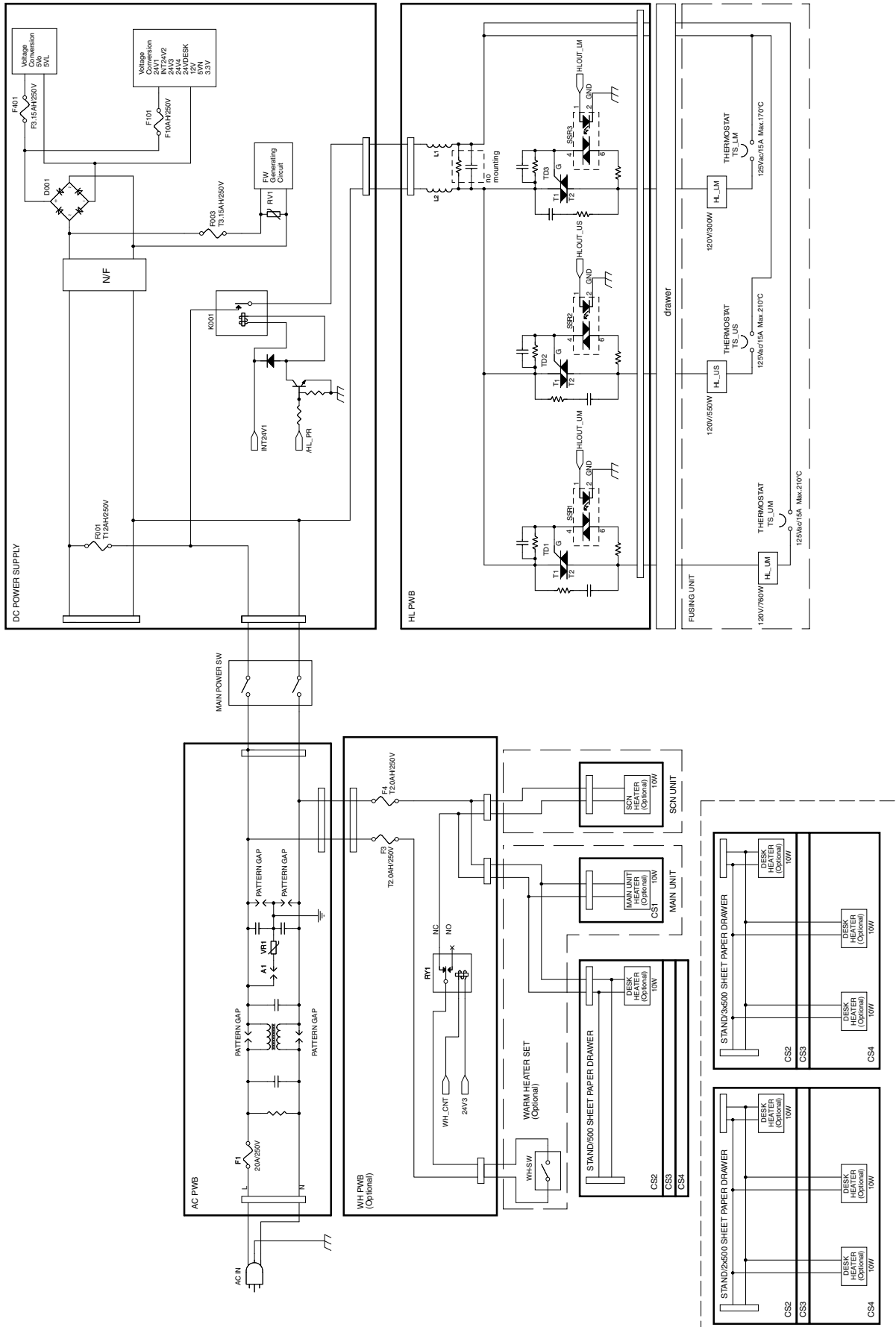





(2) 20cpm machine

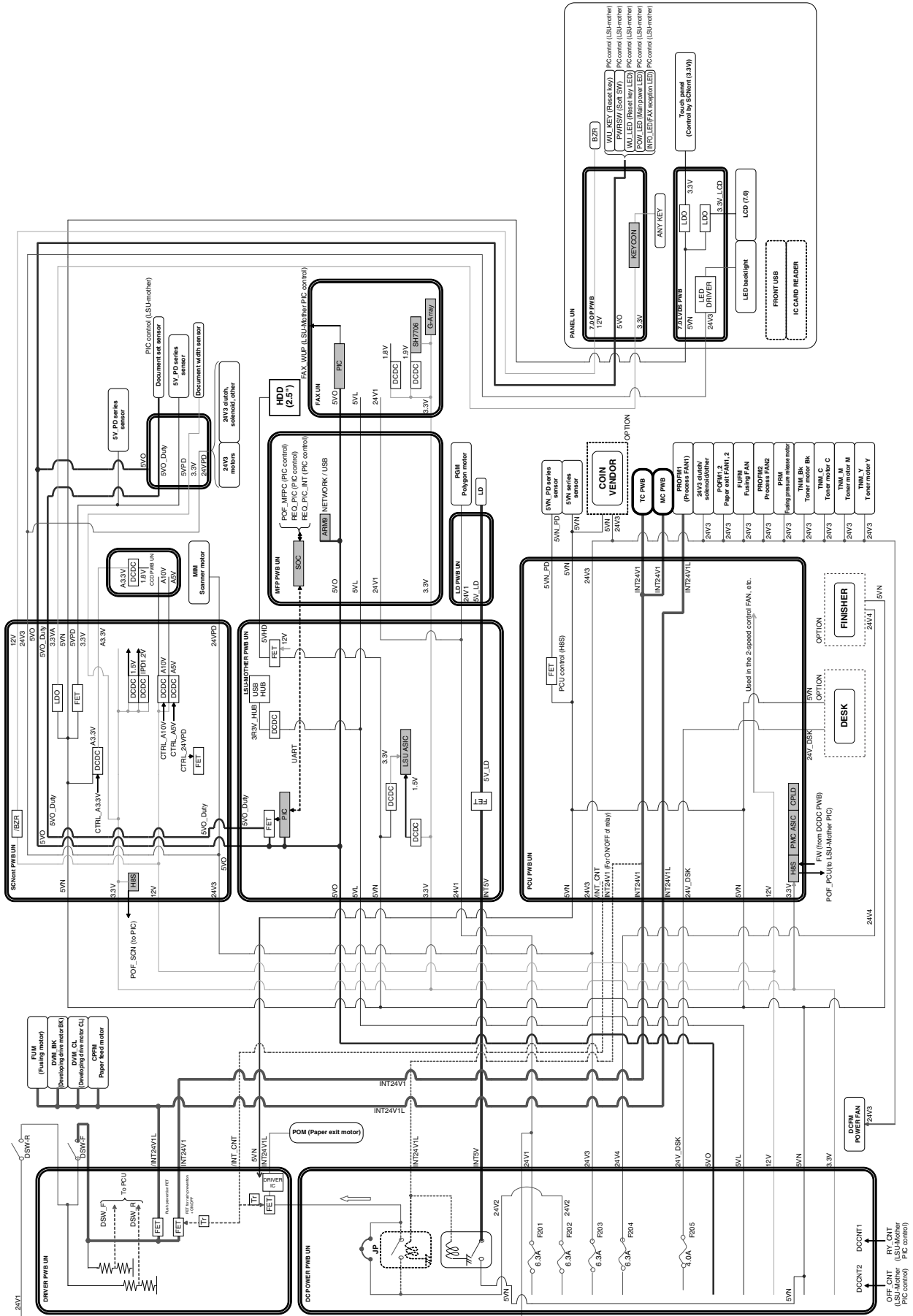

(3) 23cpm/31cpm(G) machine

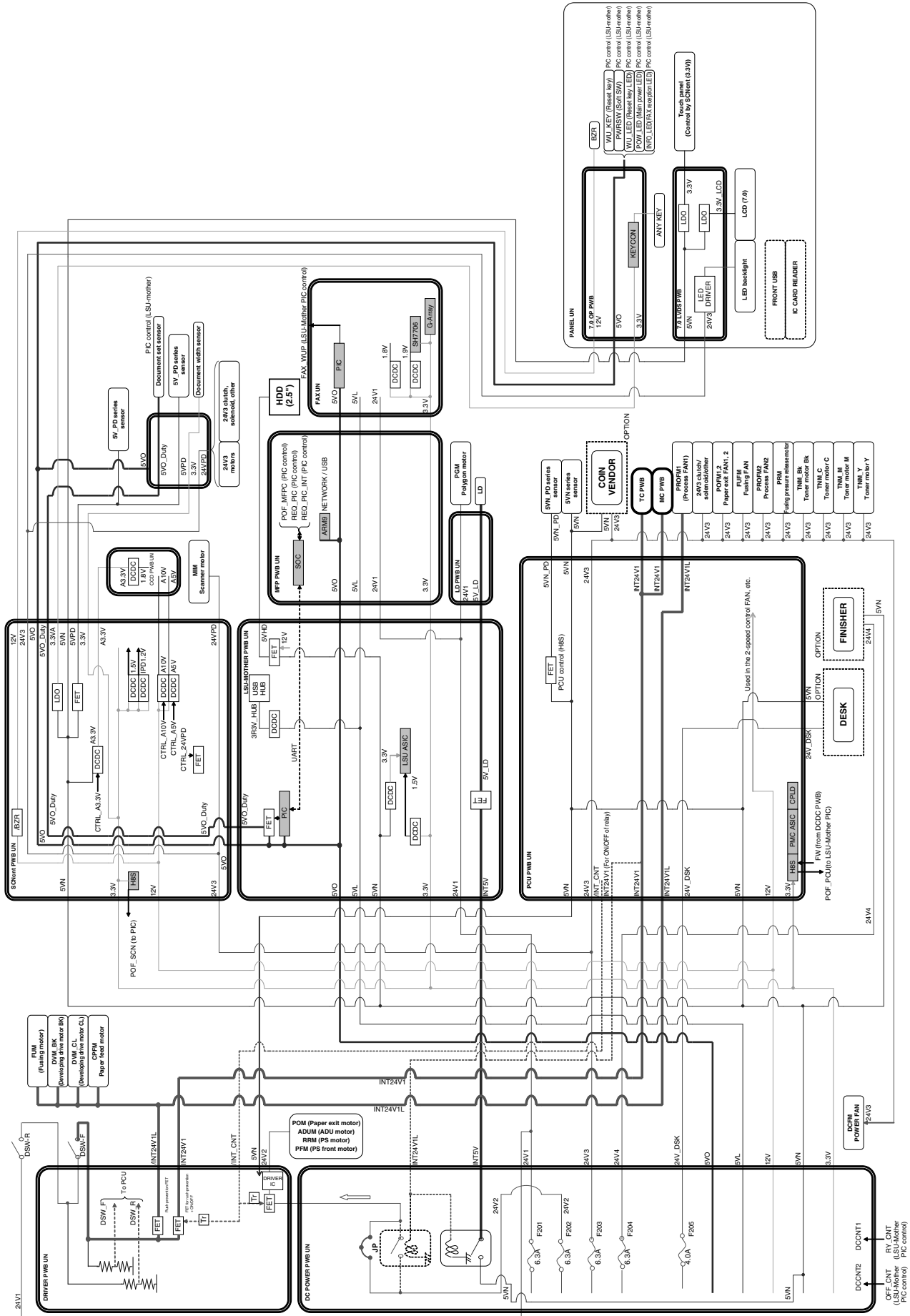







(2) 23cpm/31cpm(G) machine

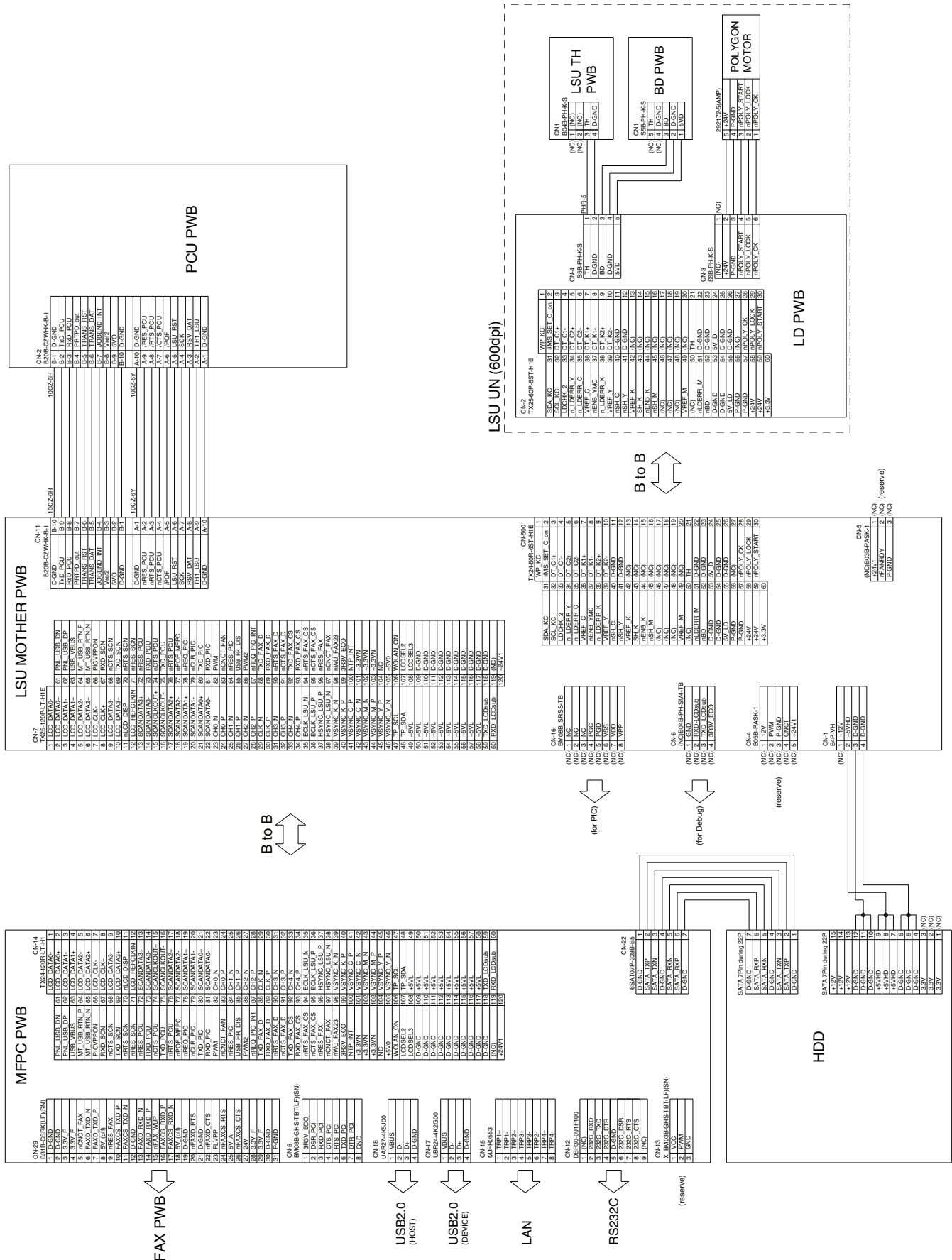

(3) 26cpm/36cpm/31cpm(A) machine

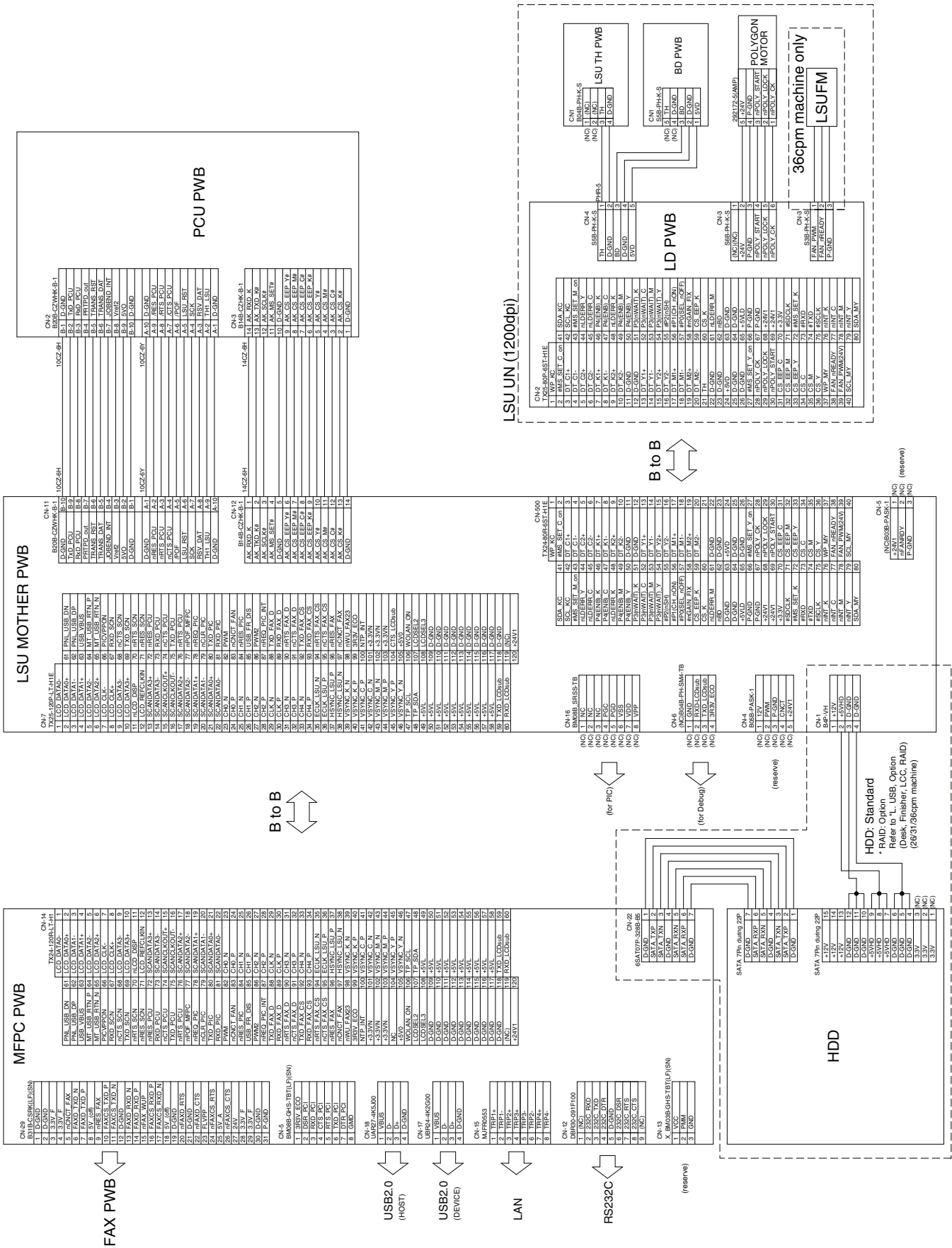



(2) 20cpm/23cpm/31cpm(G) machine

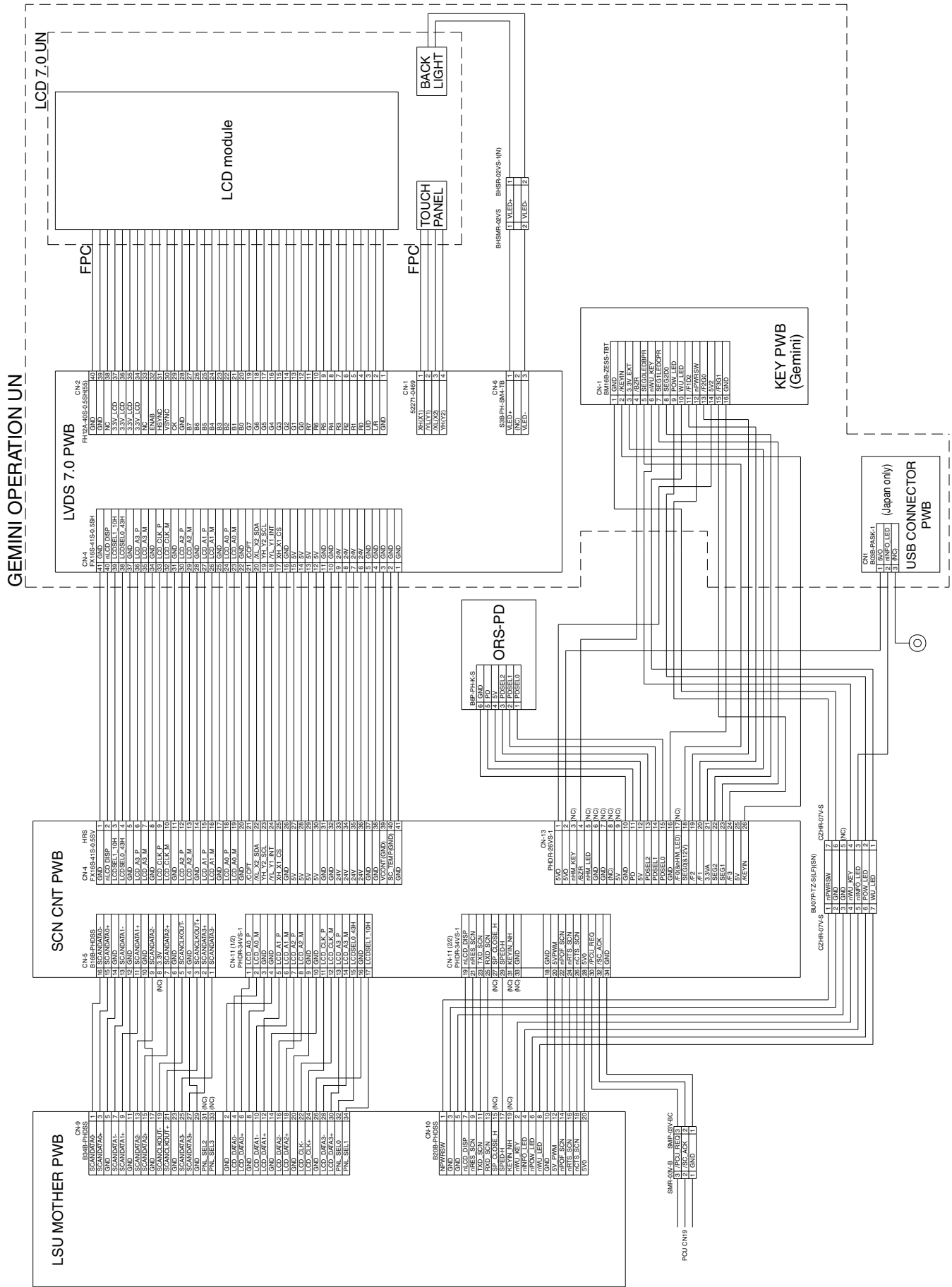



# C. Scanner, RSPF

## (1) 18cpm/20cpm machine

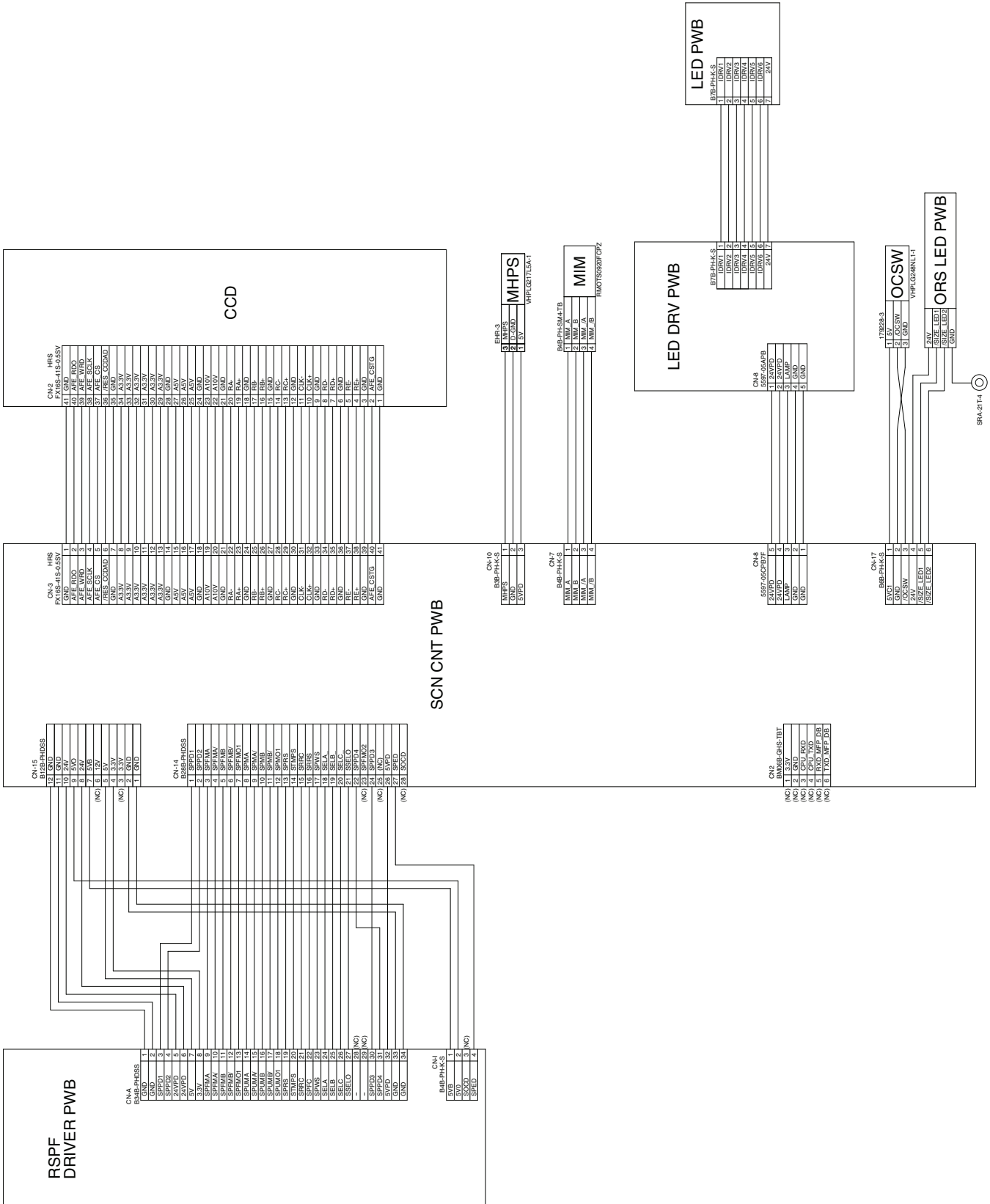

(2) 23cpm/26cpm/31cpm/36cpm machine

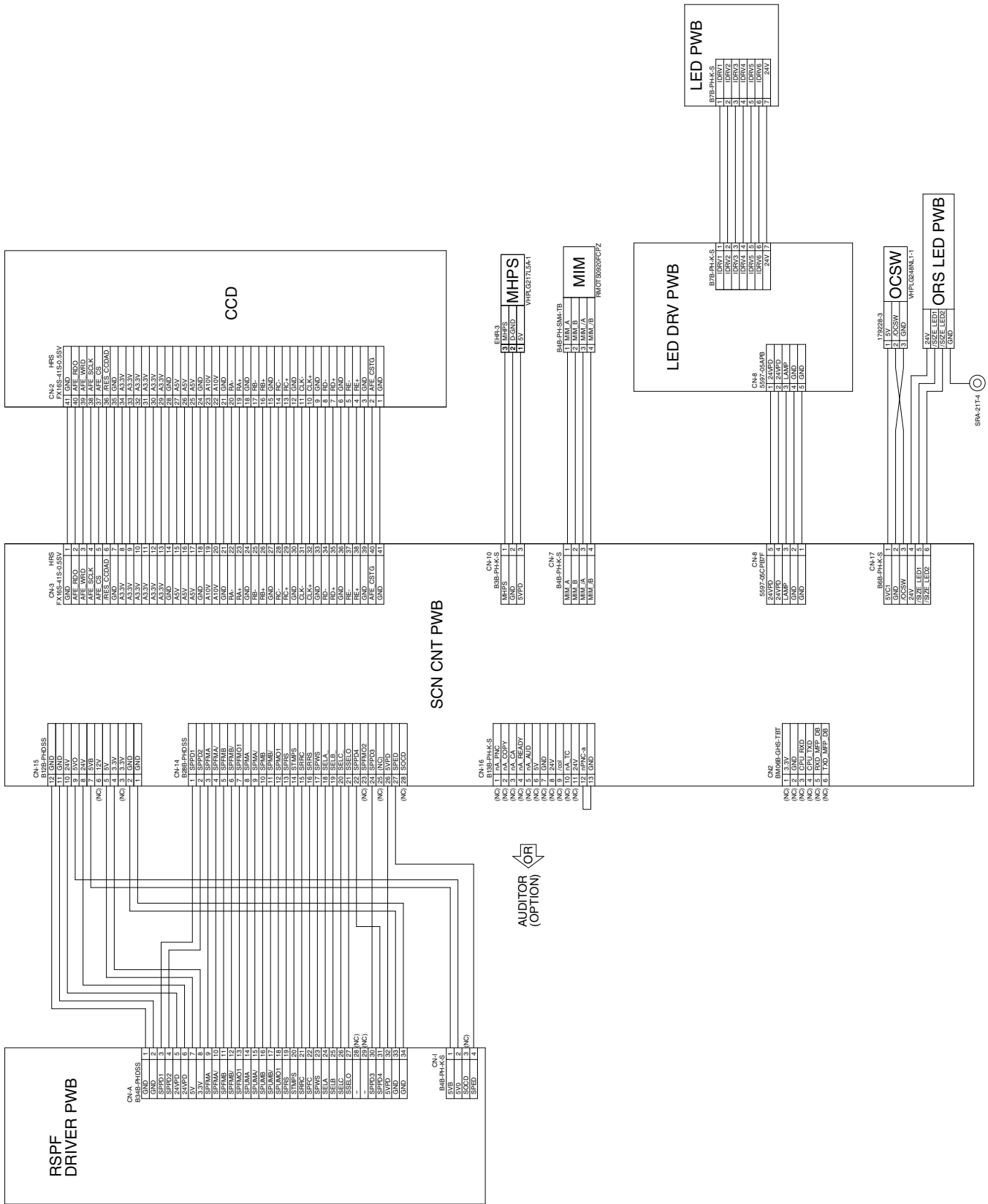

# D. CSS1, Paper feed, Transport, Main drive, RESI

## (1) 18cpm/20cpm/23cpm/26cpm/31cpm machine

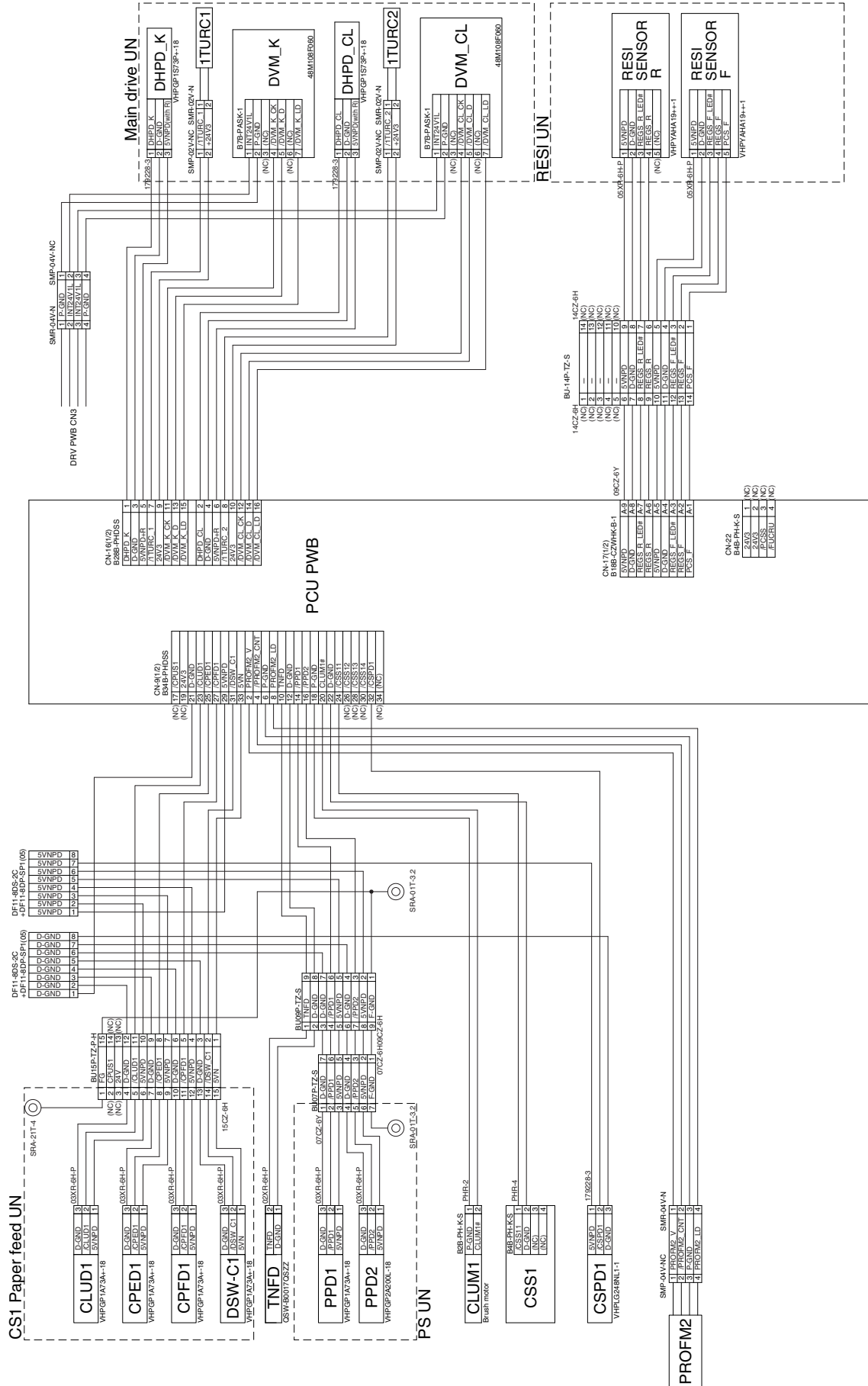





# E. Right door, Manual paper feed

(1) 18cpm machine

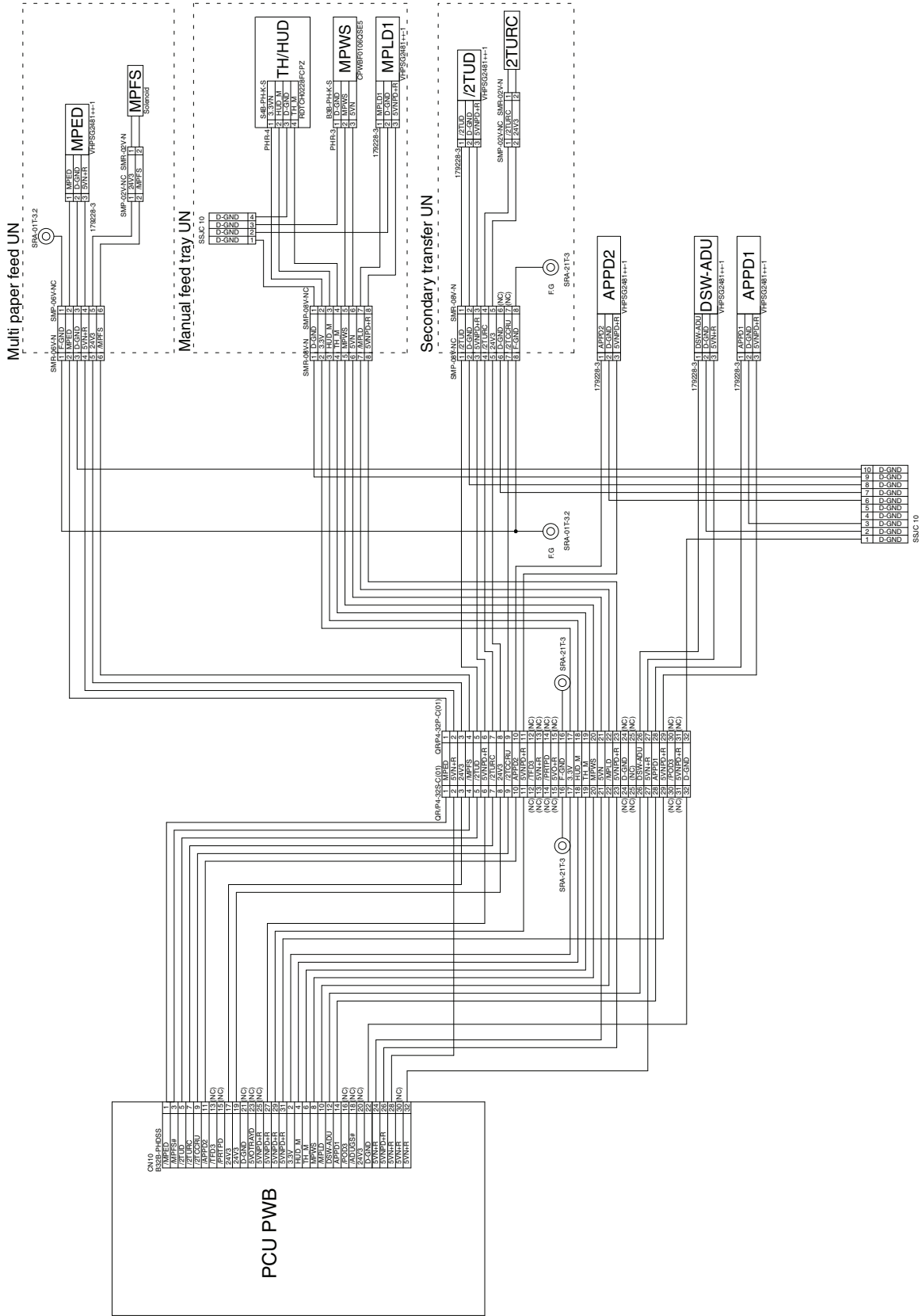



(3) 36cpm machine

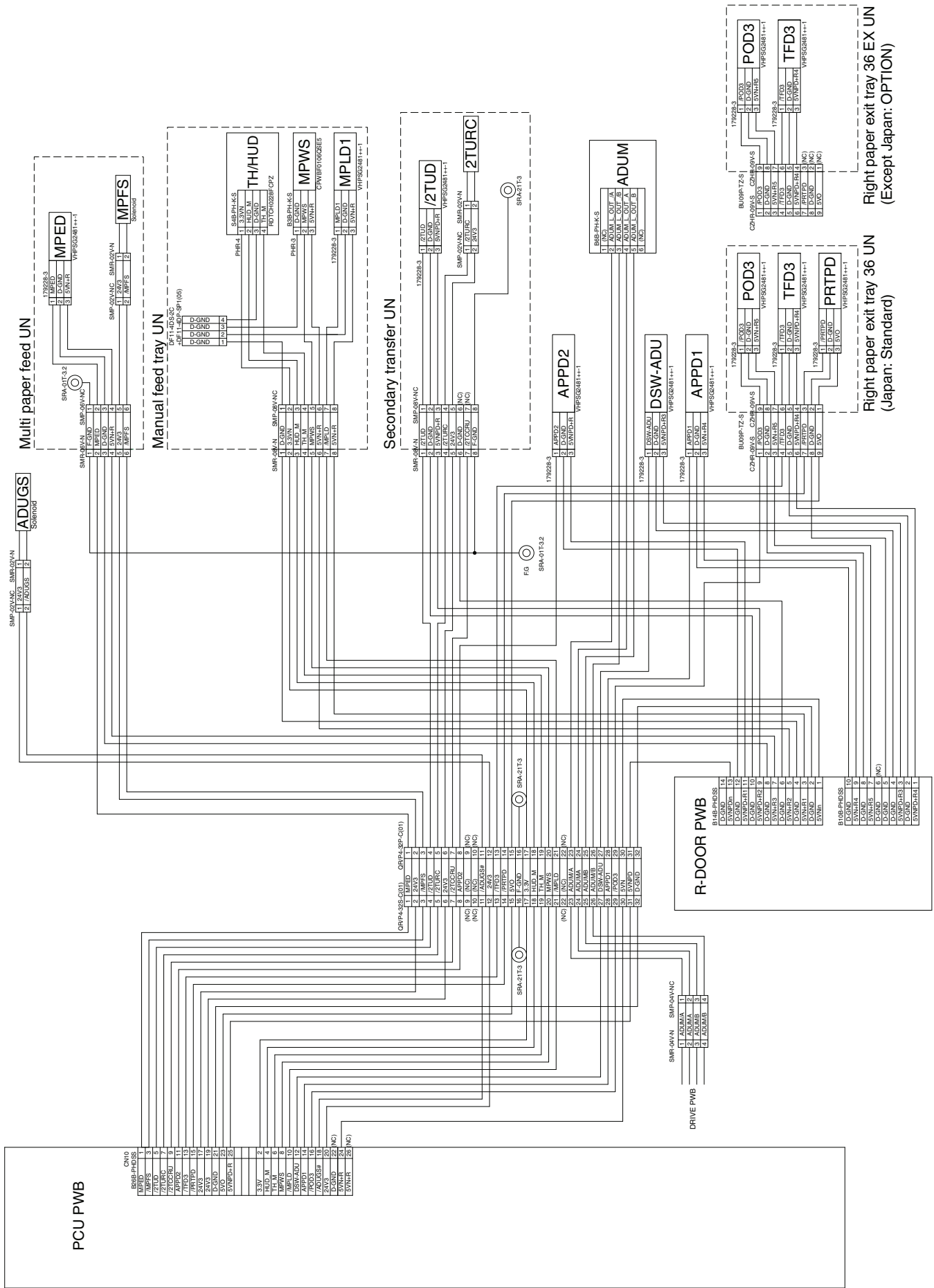

Right paper exit tray 36 EX UN  
(Except Japan: OPTION)

Right paper exit tray 36 UN  
(Japan: Standard)

# F. Paper exit, Frame fusing, DRV PWB

(1) 18cpm machine

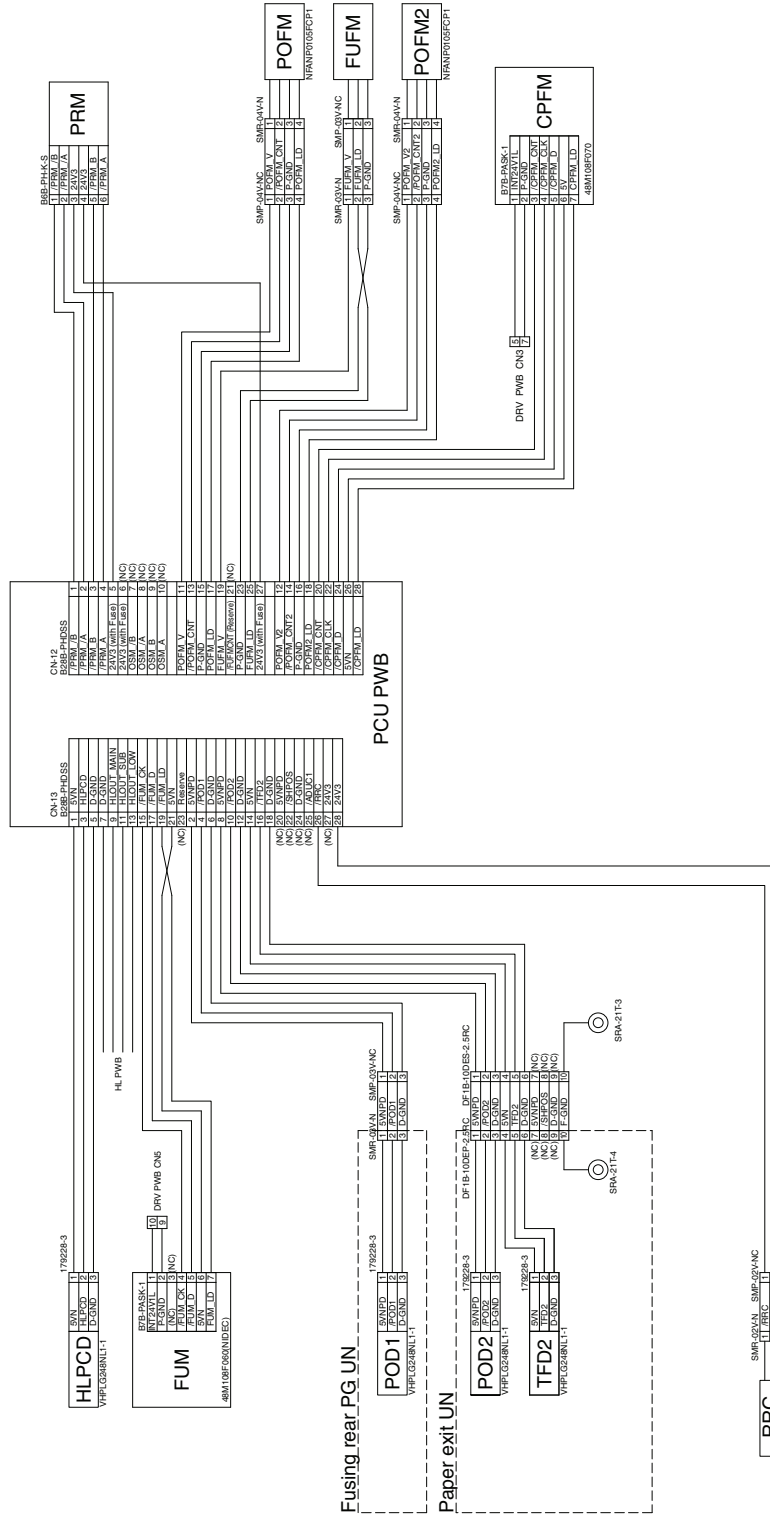

(2) 20cpm machine

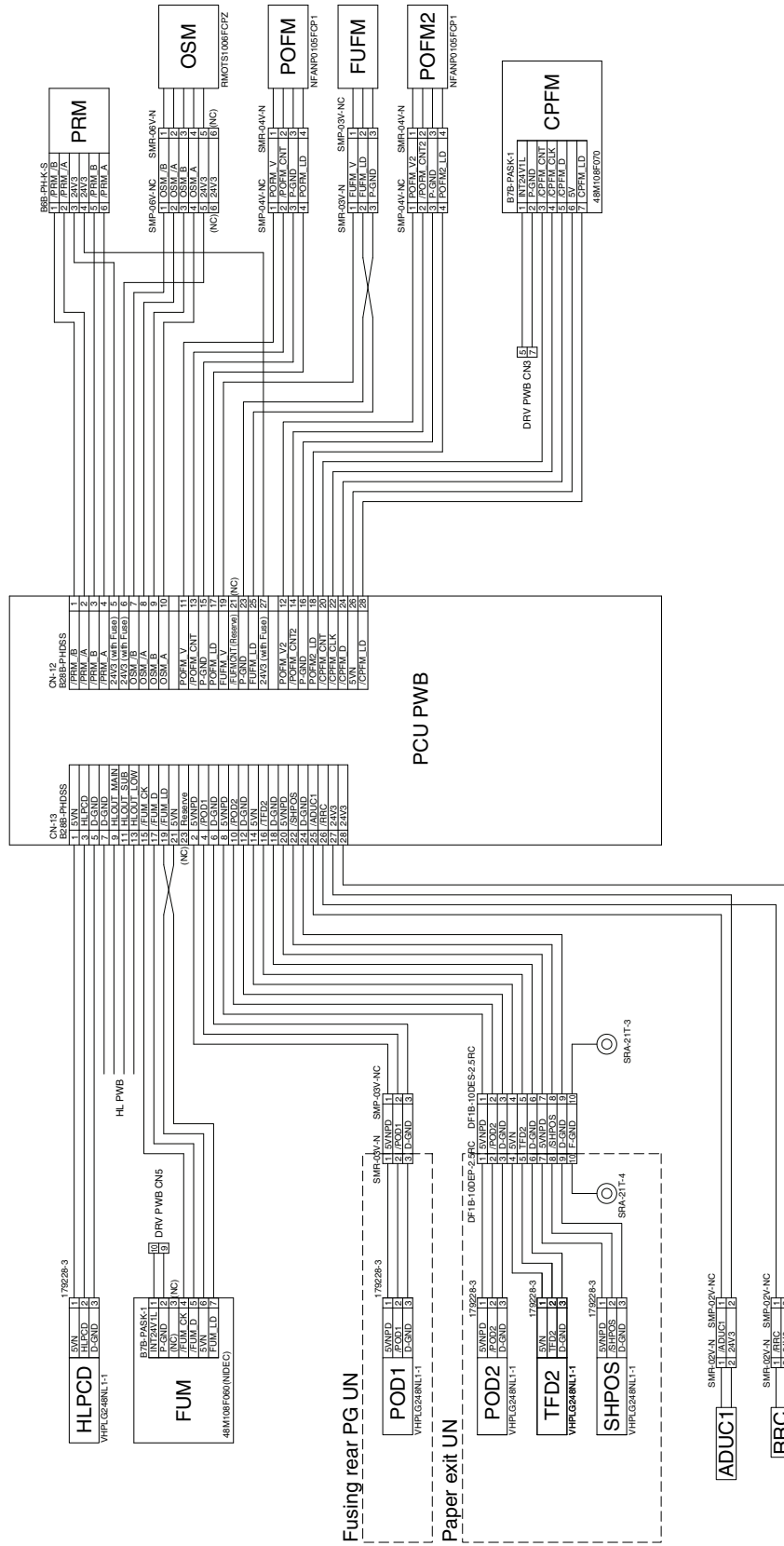

(3) 23cpm/26cpm/31cpm machine

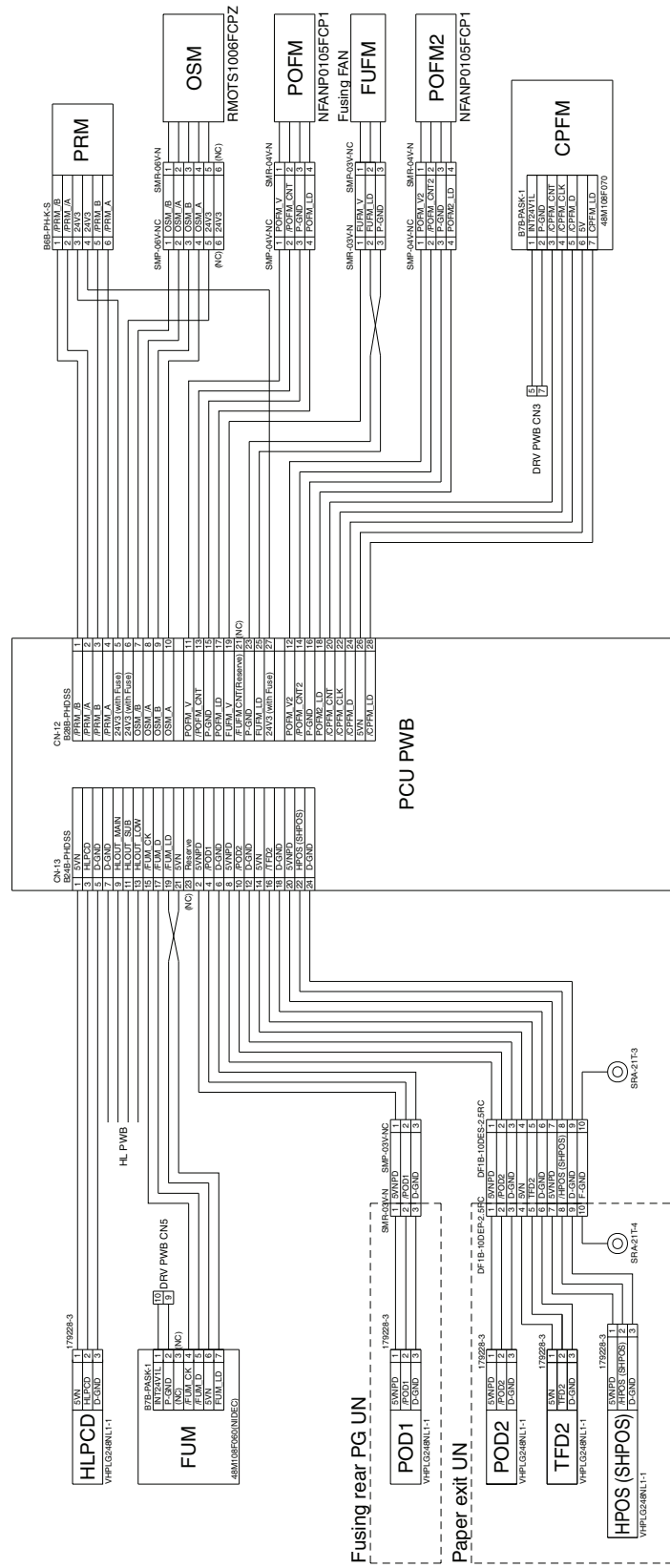

(4) 36cpm machine

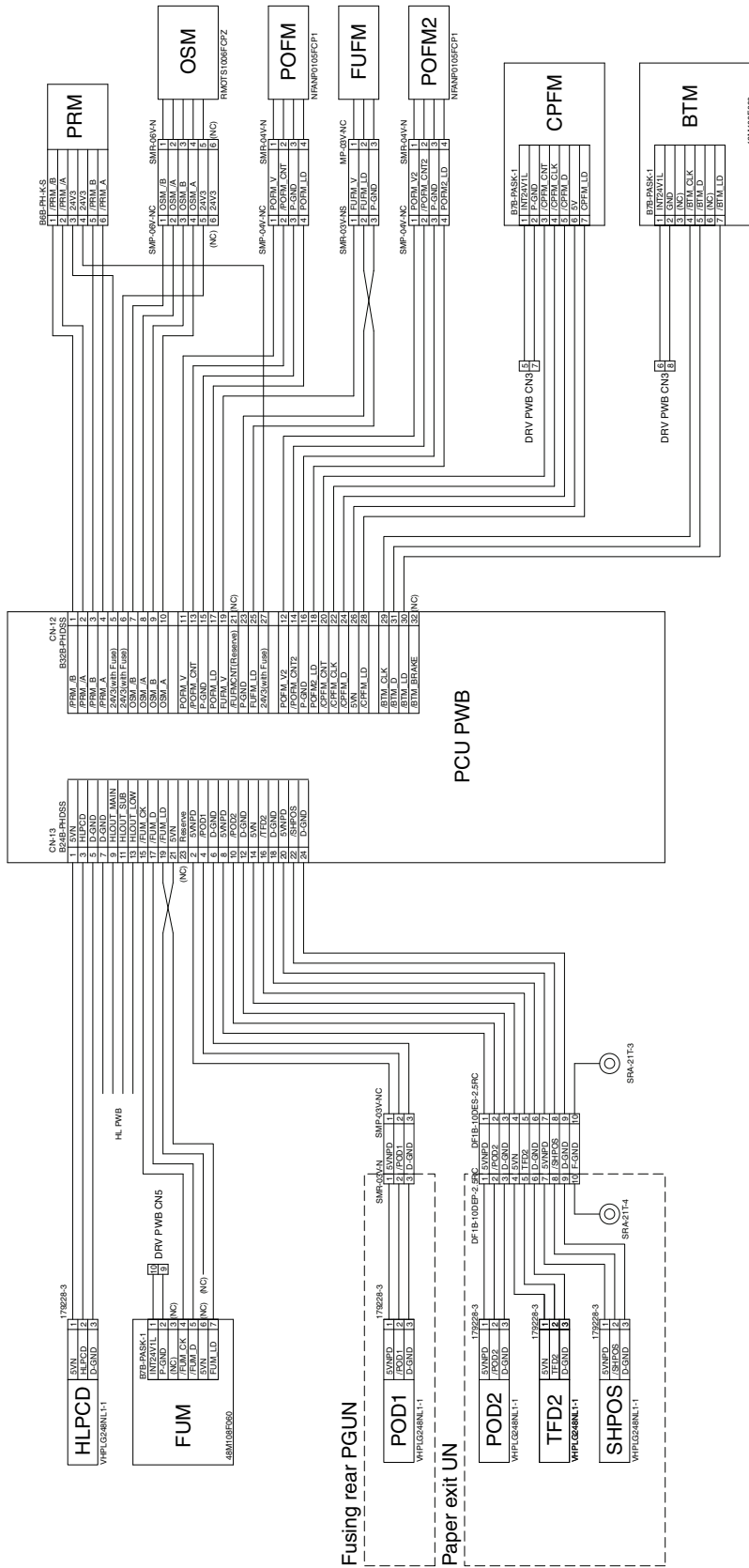





(2) 23cpm/31cpm(G) machine

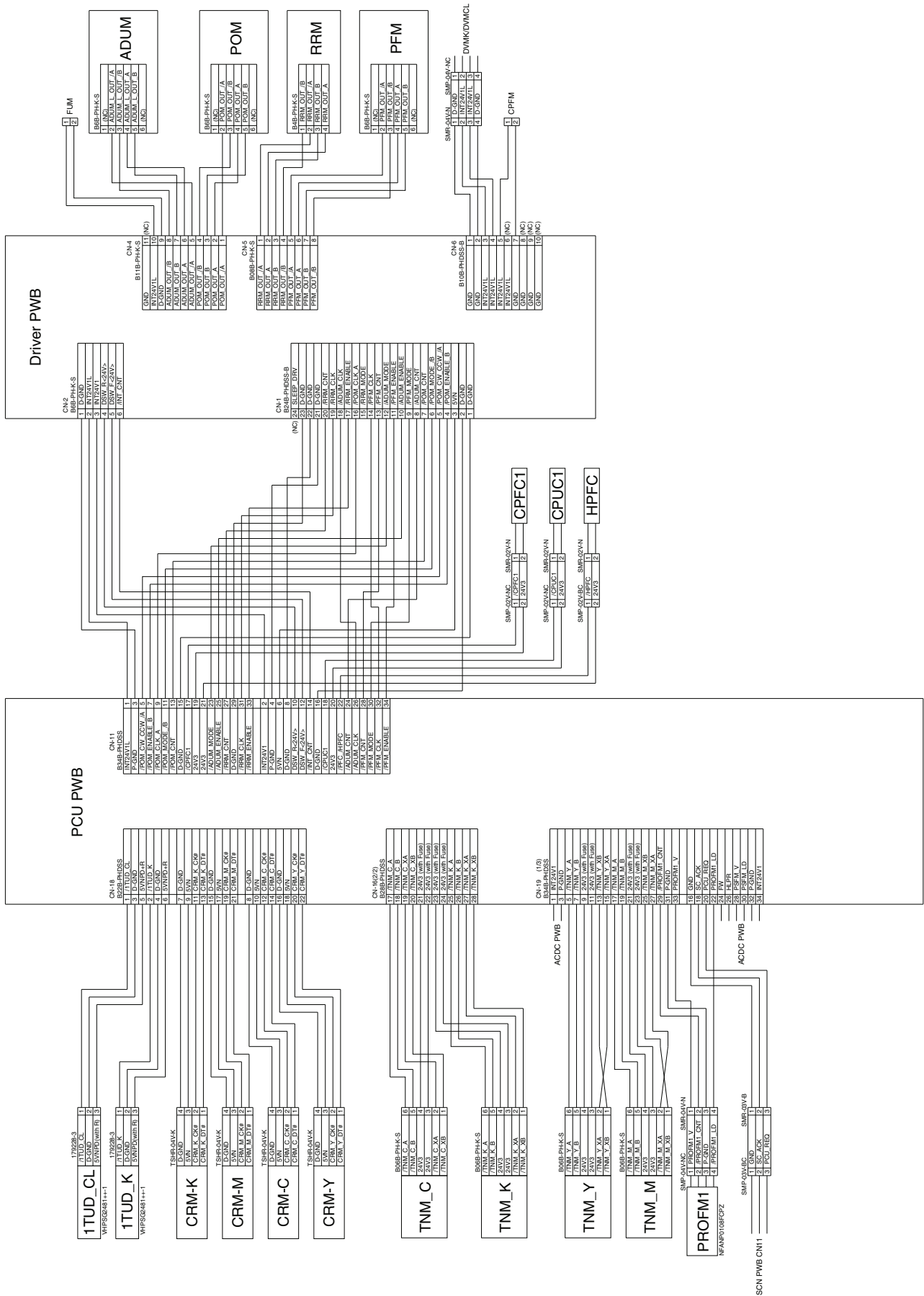



(4) 36cpm machine

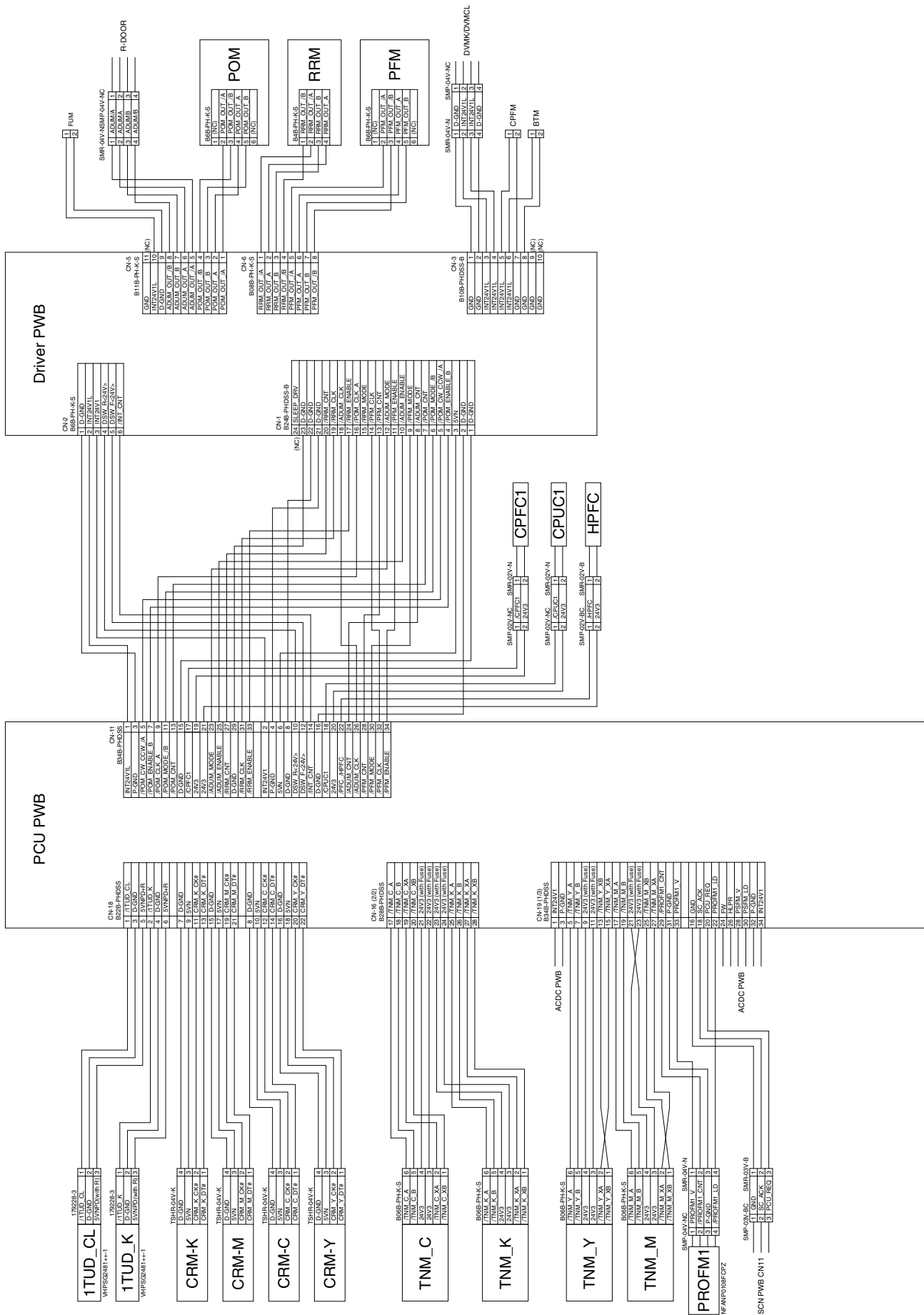





# I. Power supply

## (1) 18cpm/20cpm/23cpm machine

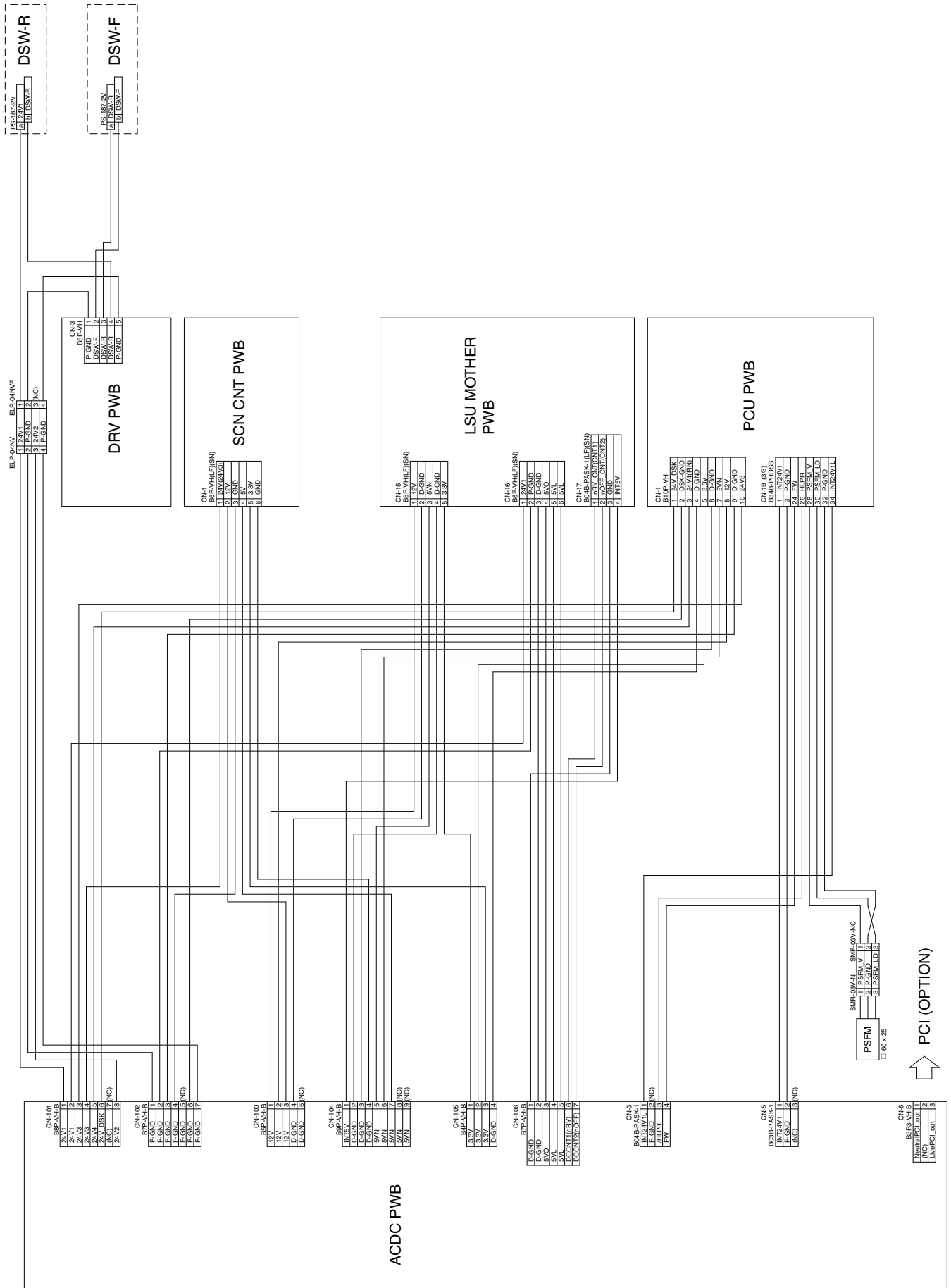

(2) 26cpm/31cpm/36cpm machine

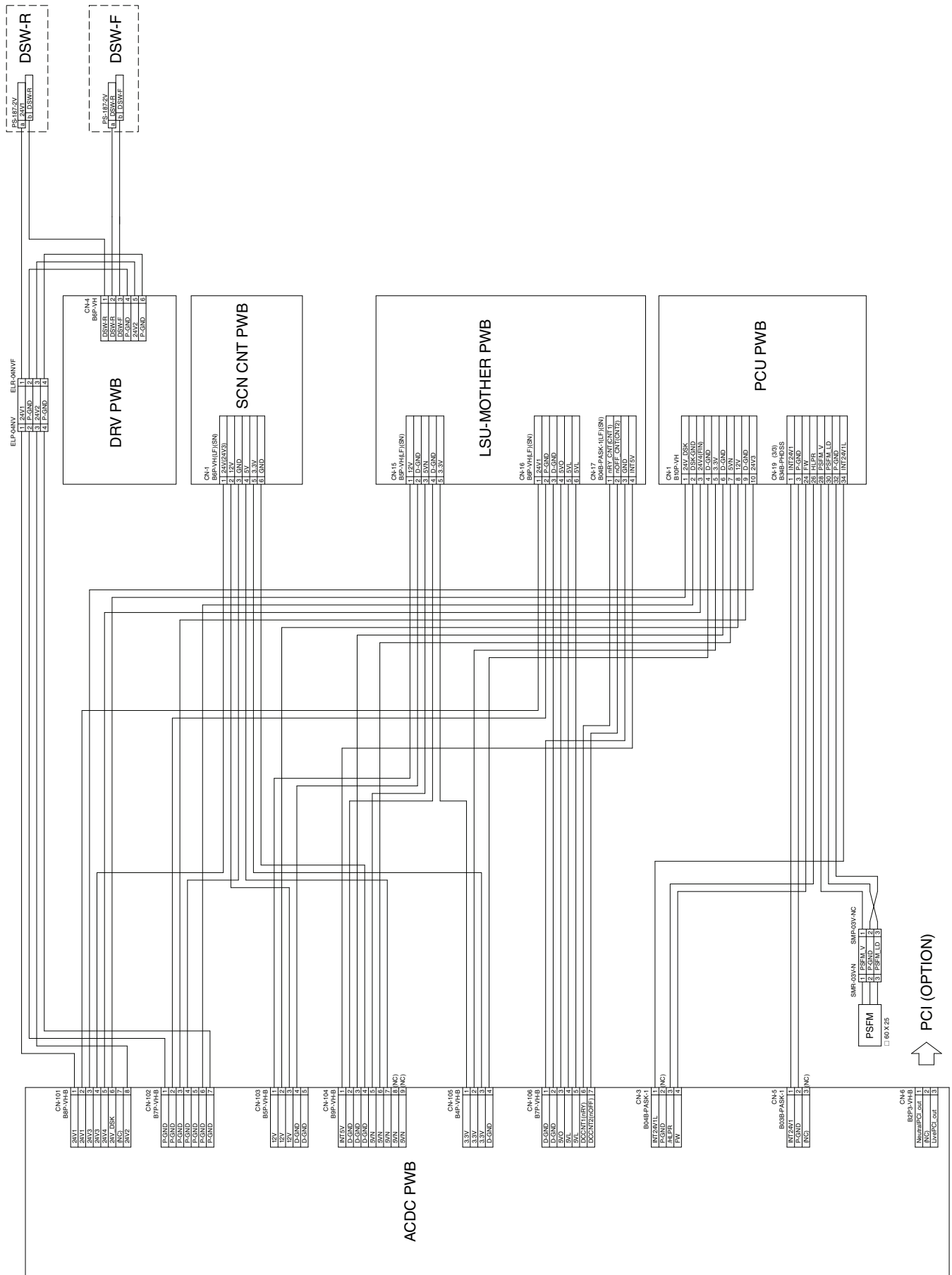



**J. AC, Fusing**  
**(1) 18cpm machine**

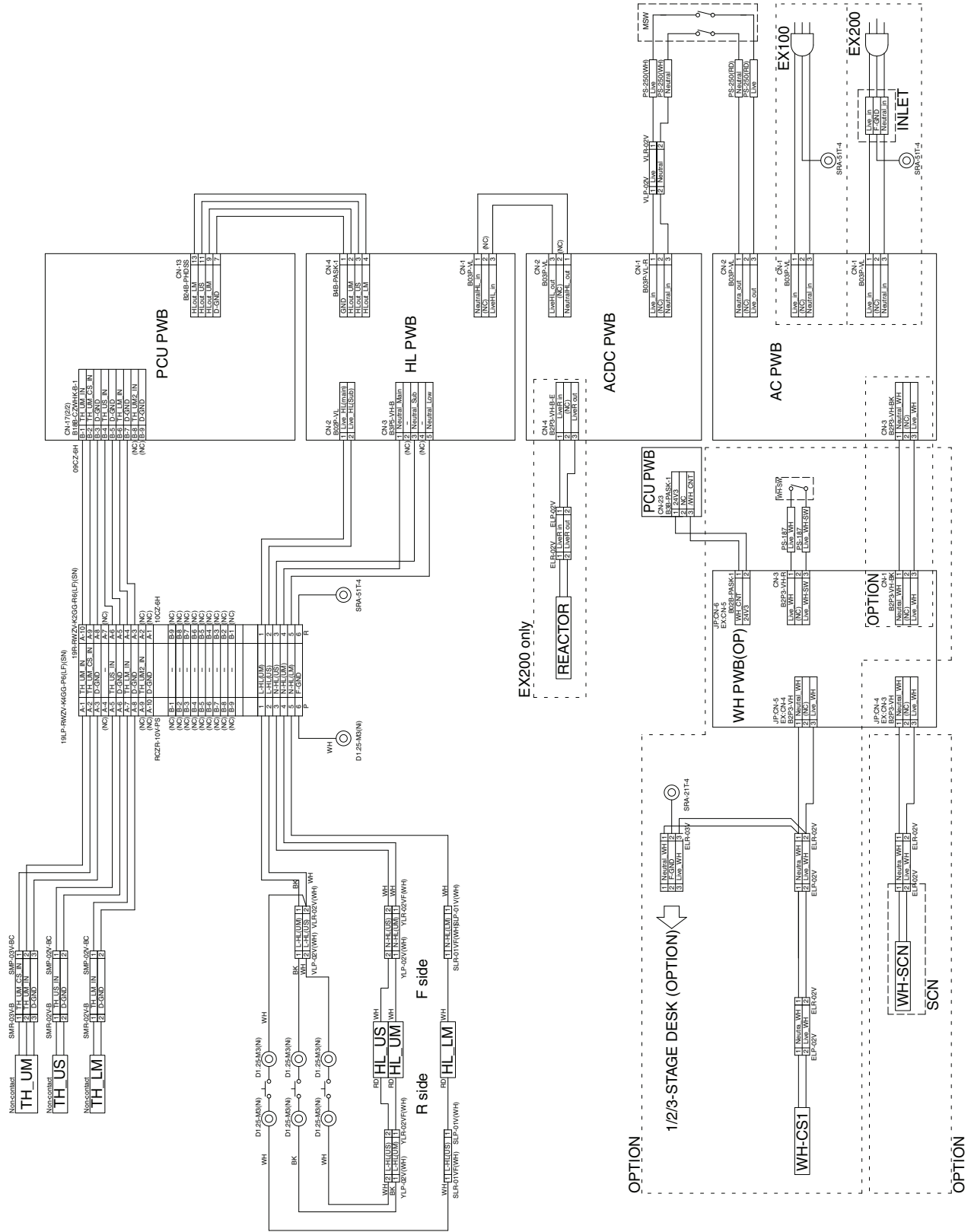

(2) 20cpm machine

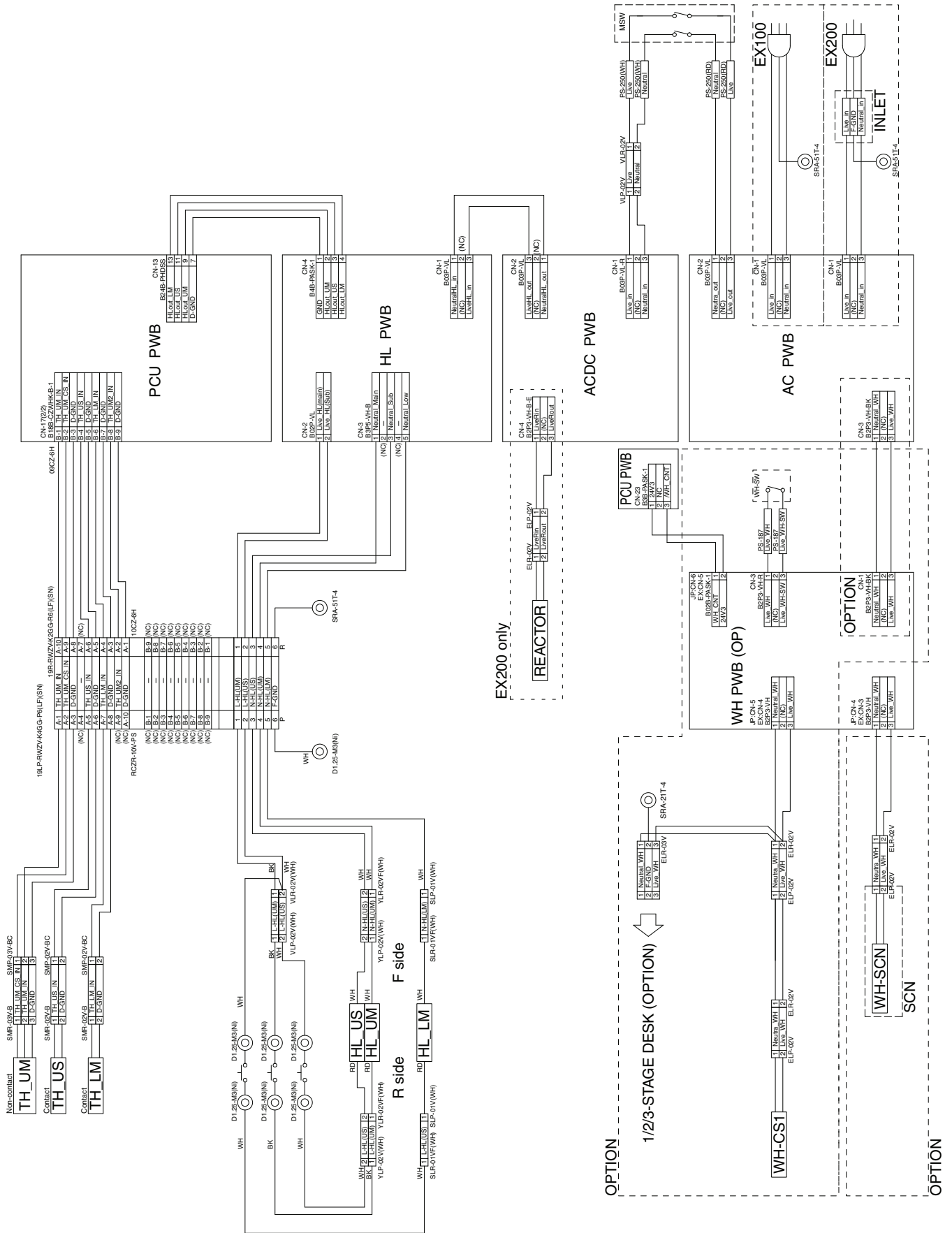









# K. USB, Option (Desk, Finisher)

## (1) 18cpm machine

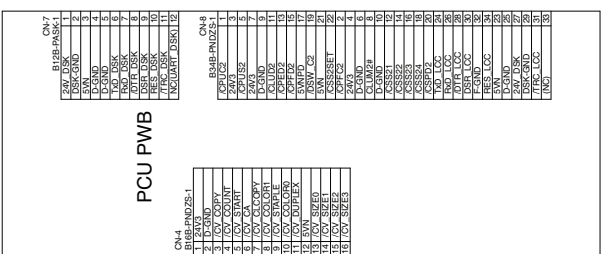
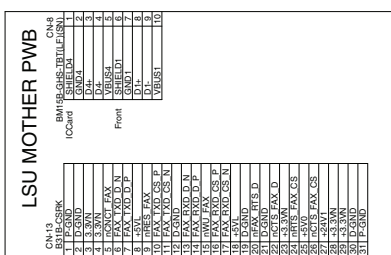
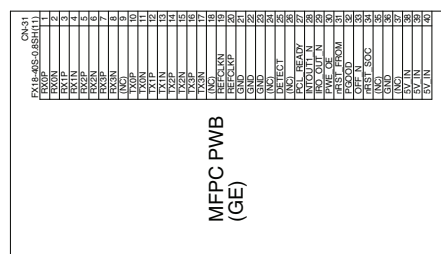
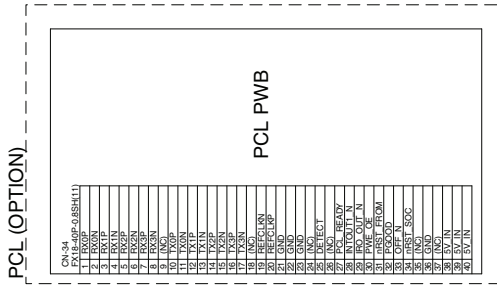

(2) 20cpm/23cpm/31cpm(G) machine

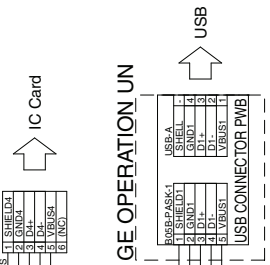
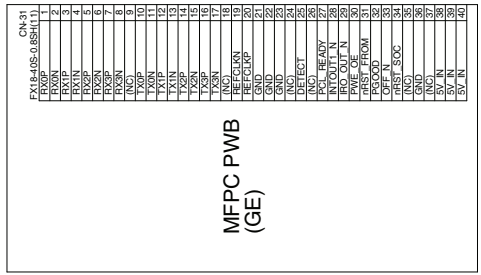
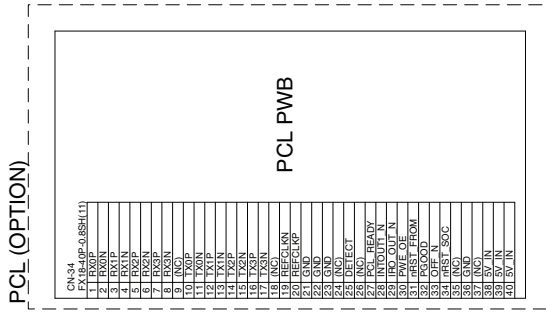





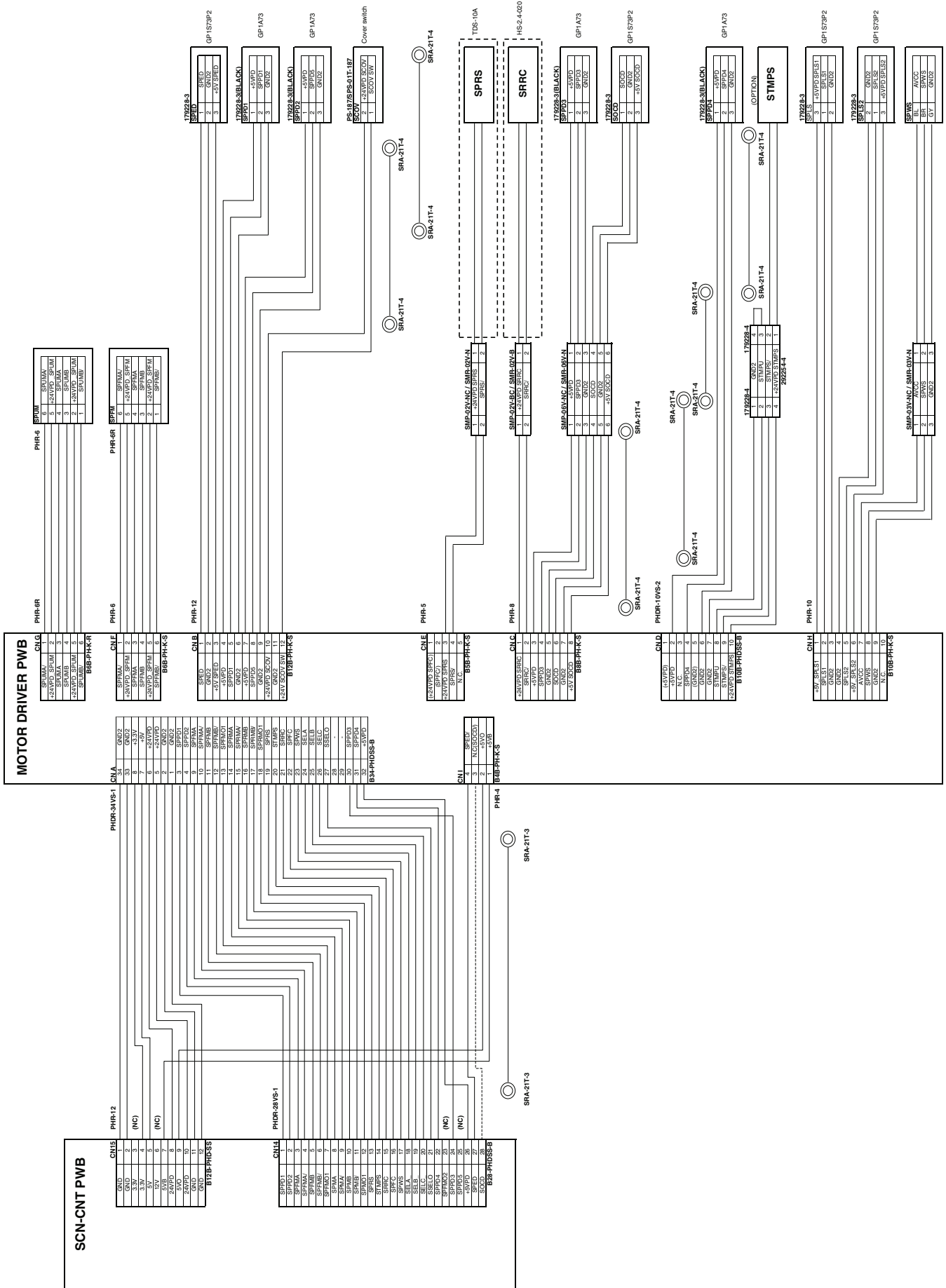

**M. FAX (Option)**

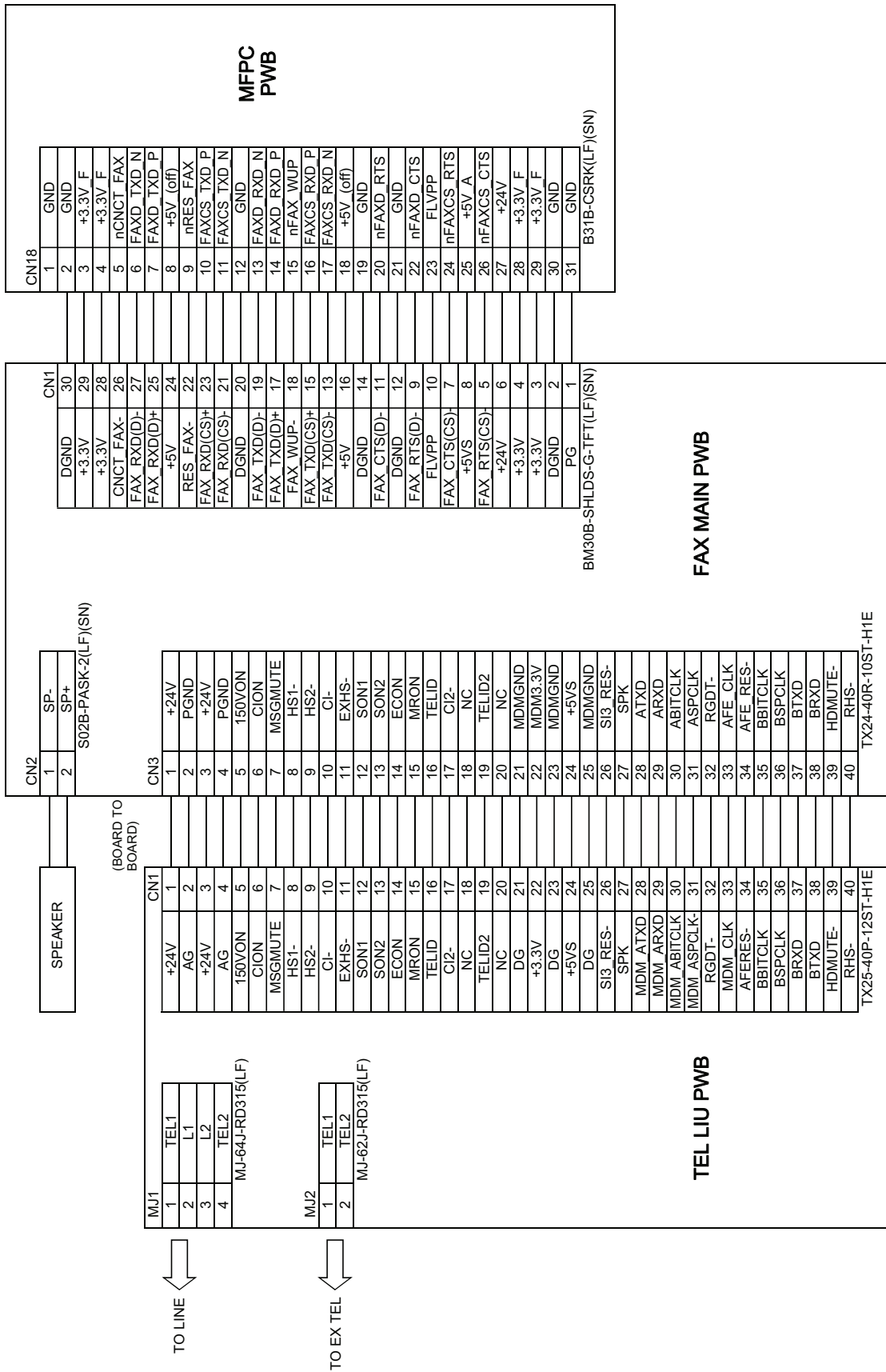

## 4. Signal list

### A. 18cpm/20cpm machine

Signal name	Name [Type]	Function/Operation	Connector level		Connector No.	Pin No.	PWB name	NOTE
			L	H				
1TUD_CL	Transfer belt separation CL detection	Detects the transfer belt separation CL.	–	–	CN18	1	PCU	
1TUD_K	Transfer belt separation BK detection	Detects the transfer belt separation BK.	–	–	CN18	2	PCU	
1TURC_1	Primary transfer separation clutch [Electromagnetic clutch]	Controls the primary transfer separation mode.	Separation select	–	CN16	7	PCU	
1TURC_2	Primary transfer separation clutch [Electromagnetic clutch]	Controls the primary transfer separation mode.	Separation select	–	CN16	8	PCU	
2TCCRU	Secondary transfer unit initial detection	Detects the initial state of the secondary transfer unit.	–	–	CN10	9	PCU	
2TUD	Secondary transfer position detection	Detects the position of the secondary transfer.	Separate	Contact	CN10	5	PCU	
2TURC	Secondary transfer separation clutch [Electromagnetic clutch]	Controls the secondary transfer separation mode.	Separation select	–	CN10	7	PCU	
ADUC1	ADU clutch	Controls the ADU clutch.	ON	OFF	CN13	25	PCU	
ADUGS	ADU gate solenoid	Controls the ADU gate solenoid.	ON	OFF	CN10	18	PCU	
APPD1	ADU transport path detection 1 [Transmission type]	Detects paper pass in the ADU upper stream section.	Pass	–	CN10	14	PCU	
APPD2	ADU transport path detection 2 [Transmission type]	ADU midstream paper pass detection	Pass	–	CN10	11	PCU	
CLUD1	Tray 1 upper limit detection (Lift HP detection) [Transmission type]	Detects the tray 1 upper limit.	–	Upper limit	CN9	23	PCU	
CLUD2	Tray 2 upper limit detection (Lift HP detection) [Transmission type]	Detects the tray 2 upper limit.	–	Upper limit	CN8	11	PCU	
CLUM1	Paper tray lift-up motor (Paper feed tray 1) [DC brush motor]	Drives the paper tray lift plate.	Stop	Drive	CN9	20	PCU	
CLUM2	Paper tray lift-up motor (Paper feed tray 2) [DC brush motor]	Drives the paper tray lift plate.	Stop	Drive	CN8	8	PCU	
CPED1	Tray 1 paper empty detection [Transmission type]	Detects paper empty in the tray 1.	YES	NO	CN9	25	PCU	
CPED2	Tray 2 paper empty detection [Transmission type]	Detects paper empty in the tray 2.	YES	NO	CN8	13	PCU	
CPFC1	Tray vertical transport clutch 1 [Electromagnetic clutch]	Controls ON/OFF of the paper transport roller in the paper feed tray section.	ON	OFF	CN11	17	PCU	
CPFC2	Tray vertical transport clutch 2 [Electromagnetic clutch]	Controls ON/OFF of the paper transport roller in the paper feed tray section.	ON	OFF	CN8	2	PCU	
CPFD1	Tray 1 transport detection (Paper entry detection) [Transmission type]	Detects paper pass in the tray 1.	Pass	–	CN9	27	PCU	
CPFD2	Tray 2 transport detection (Paper entry detection) [Transmission type]	Detects paper pass in the tray 2.	Pass	–	CN8	15	PCU	
CPFM_D	Paper feed motor [Brushless motor]	Drives the paper feed section.	Drive	Stop	CN12	24	PCU	
CPFM_LD	Paper feed motor lock detection	Detects the paper feed motor lock.	–	Lock detection	CN12	28	PCU	
CPUC1	Paper feed clutch (Paper feed tray 1) [Electromagnetic clutch]	Controls ON/OFF of the roller in the paper feed tray section.	ON	OFF	CN11	18	PCU	
CPUC2	Paper feed clutch (Paper feed tray 2) [Electromagnetic clutch]	Controls ON/OFF of the roller in the paper feed tray section.	ON	OFF	CN8	1	PCU	
CPUS1	Paper feed pickup solenoid (Paper feed tray 2) [Solenoid]	Controls the paper pickup solenoid.	ON	OFF	CN9	17	PCU	
CPUS2	Paper feed pickup solenoid (Paper feed tray 2) [Solenoid]	Controls the paper pickup solenoid.	ON	OFF	CN8	5	PCU	
CSPD1	Tray 1 remaining paper quantity detection	Detects the remaining paper quantity in the tray 1.	Remaining quantity	–	CN9	32	PCU	Detects during lifting up.
CSPD2	Tray 2 remaining paper quantity detection	Detects the remaining paper quantity in the tray 2.	Remaining quantity	–	CN8	20	PCU	Detects during lifting up.
CSS11	Tray 1 detection	Detects the tray 1.	YES	NO	CN9	24	PCU	
CSS21	Tray 2 detection	Detects the tray 2.	YES	NO	CN8	12	PCU	
CSS2SET	Cassette 2 unit detection	Detects the cassette 2 unit.	YES	NO	CN8	22	PCU	
DHPD_CL	CL phase detection	Detects the CL phase.	Reference	–	CN16	2	PCU	

Signal name	Name [Type]	Function/Operation	Connector level		Connector No.	Pin No.	PWB name	NOTE
			L	H				
DHPD_K	BK phase detection	Detects the BK phase.	Reference	–	CN16	1	PCU	
DL_BK	Discharge lamp BK [LED]	Discharges electric charges on the OPC drum.	OFF	ON	CN14	8	PCU	
DL_C	Discharge lamp C [LED]	Discharges electric charges on the OPC drum.	OFF	ON	CN14	4	PCU	
DL_M	Discharge lamp M [LED]	Discharges electric charges on the OPC drum.	OFF	ON	CN14	7	PCU	
DL_Y	Discharge lamp Y [LED]	Discharges electric charges on the OPC drum.	OFF	ON	CN14	3	PCU	
DSW_ADU	ADU transport open/close detection [Transmission type]	Detects ADU cover open/close.	Open	Close	CN10	12	PCU	
DSW_C1	Tray 1 transport cover open/close detection	Detects tray 1 transport cover open/close.	Open	Close	CN9	31	PCU	
DSW_C2	Tray 2 transport cover open/close detection	Detects tray 2 transport cover open/close.	Open	Close	CN8	19	PCU	
DSW_F	Front door open/close switch [Micro switch]	Detects open/close of the front door, and fusing, motor, LSU laser power line.	Open	Close	CN11	12	PCU	
DSW_R	Right door open/close switch [Micro switch]	Detects open/close of the right door unit, and fusing, motor, LSU laser power line.	Open	Close	CN11	10	PCU	
DVM_CL_D	Development drive motor (CL) [Brushless motor]	Drives the development section, the color OPC drum, and the transfer section.	Drive	Stop	CN16	14	PCU	
DVM_CL_LD	Development drive motor (CL) lock detection	Detects the development drive motor (CL) lock.	–	Lock detection	CN16	16	PCU	
DVM_K_D	Development drive motor (K) [Brushless motor]	Drives the development section, the black OPC drum, and the transfer section.	Drive	Stop	CN16	13	PCU	
DVM_K_LD	Development drive motor (K) lock detection	Detects the development drive motor (K) lock.	–	Lock detection	CN16	15	PCU	
FUFM_LD	Fusing fan motor lock detection	Detects the fusing fan motor lock.	–	Lock detection	CN12	25	PCU	
FUFM_V	Fusing fan motor	Cools the motor related to the fusing and the paper exit sections.	OFF	ON	CN12	19	PCU	
FUM_D	Fusing drive motor [Brushless motor]	Drives the fusing unit.	Drive	Stop	CN13	17	PCU	
FUM_LD	Fusing drive motor lock detection	Detects the fusing drive motor lock.	–	Lock detection	CN13	19	PCU	
HL_LM_out	Lower heater lamp	Turns ON/OFF the lower heater lamp.	OFF	ON	CN13	13	PCU	
HL_UM_out	Heater lamp main	Turns ON/OFF the heater lamp main.	OFF	ON	CN13	9	PCU	
HL_US_out	Heater lamp sub	Turns ON/OFF the heater lamp sub.	OFF	ON	CN13	11	PCU	
HLPCD	Fusing pressure detection sensor [Transmission sensor]	Detects a change in the fusing pressure.	Pressure release	Pressure applying	CN13	3	PCU	
HUD_M	Humidity detection	Detects the humidity.	–	–	CN10	4	PCU	Analog detection
INT_CNT	Interlock control	ON/OFF control of INT24V1,V2	ON	OFF	CN11	14	PCU	
MPED	Manual feed paper empty detection [Transmission type]	Detects paper empty in the manual paper feed tray.	YES	NO	CN10	1	PCU	
MPFS	Paper pickup solenoid (Manual paper feed) [Electromagnetic solenoid]	Paper pickup solenoid (Manual paper feed) [Electromagnetic solenoid]	Pickup	–	CN10	3	PCU	
MPLD	Manual feed paper length detector	Detects the paper length in the manual paper feed tray.	–	Detection	CN10	10	PCU	
MPWS	Manual feed tray paper width sensor	Detects the paper width in the manual feed tray.	–	–	CN10	8	PCU	
OSM	Shifter motor [Stepping motor]	Offsets the paper.	–	–	CN12	7, 8, 9, 10	PCU	Drives with the 4-phase signal.
PFC_HPFC	PS front clutch	Controls the PS front clutch.	ON	OFF	CN11	22	PCU	
POD1	Fusing rear detection [Transmission type]	Detects the paper exit from fusing.	Pass	–	CN13	4	PCU	
POD2	Paper exit detection [Transmission type]	Detects the discharged paper.	Pass	–	CN13	10	PCU	
POD3	Right tray paper exit detection	Detects paper exit to the right tray.	Pass	–	CN10	16	PCU	
POFM_CNT	Paper exit cooling fan motor speed control	Controls the speed of the paper exit cooling fan motor.	–	–	CN12	13, 14	PCU	Pulse (Duty) drive

Signal name	Name [Type]	Function/Operation	Connector level		Connector No.	Pin No.	PWB name	NOTE
			L	H				
POFM_LD1	POFM lock detection	Detects the POFM lock.	–	Lock detection	CN12	17	PCU	
POFM_LD2	POFM lock detection	Detects the POFM lock.	–	Lock detection	CN12	18	PCU	
POFM_V	Paper exit cooling fan motor	Cools the fusing unit.	Stop	Drive	CN12	11,12	PCU	
POM	Paper exit drive motor	Drives the paper exit roller.	–	–	CN11	5, 7, 9, 11	PCU	
POM_CNT	Paper exit drive motor current select	Selects the paper exit drive motor current.	Current Large	Current Small	CN11	13	PCU	
PPD1	Registration front detection [Transmission type]	Detects paper in front of the registration roller.	Pass	–	CN9	14	PCU	
PPD2	Registration detection	Detects paper at the rear of the registration roller.	Pass	–	CN9	16	PCU	
PRM	Fusing pressure release motor [Stepping motor]	Changes the fusing voltage.	–	–	CN12	1, 2, 3, 4	PCU	Drives with the 4-phase signal.
PROFM1_CNT	Process fan motor 2 speed control	Controls the speed of the process fan motor.	–	–	CN19	29	PCU	
PROFM1_LD	Process fan motor 2 lock detection	Process fan motor lock detection	–	Lock detection	CN19	22	PCU	
PROFM1_V	Process fan motor 2	Cools the process.	OFF	ON	CN19	33	PCU	
PROFM2_CNT	Process fan motor 2 speed control	Controls the speed of the process fan motor 2.	–	–	CN9	4	PCU	Pulse (Duty) drive
PROFM2_LD	Process fan motor 2 lock detection	Detects process fan motor 2 lock.	–	Lock detection	CN9	8	PCU	
PROFM2_V	Process fan motor 2	Cools the process.	OFF	ON	CN9	2	PCU	
PRTPD	Right paper exit tray paper empty detection	Detects paper empty in the right paper exit tray.	NO	YES	CN10	15	PCU	
PSFM_LD	Power cooling fan motor lock detection	Detects the power cooling fan motor lock.	–	Lock detection	CN19	30	PCU	
PSFM_V	Power cooling fan motor	Cools the power unit.	Stop	Drive	CN19	28	PCU	
REGS_F	Registration sensor (Front) [Reflection type]	Registration shift detection	–	–	CN17	A-2	PCU	Analog detection
REGS_F_LED	Registration sensor LED (Front) [LED]	Registration sensor LED light emitting	–	–	CN17	A-3	PCU	Analog output
REGS_R	Registration sensor (Rear) [Reflection type]	Registration shift detection	–	–	CN17	A-6	PCU	Analog detection
REGS_R_LED	Registration sensor LED (Rear) [LED]	Registration sensor LED light emitting	–	–	CN17	A-7	PCU	Analog output
RRC	Registration roller clutch	Controls the registration roller clutch.	ON	OFF	CN13	26	PCU	
SHPOS	Shifter home position sensor	Detects the shifter home position.	–	Home position	CN13	22	PCU	
TCS_C	Toner density sensor [Magnetic sensor]	Detects the toner density (C)	–	–	CN15	B-7	PCU	Analog detection
TCS_K	Toner density sensor [Magnetic sensor]	Detects the toner density (K)	–	–	CN15	B-16	PCU	Analog detection
TCS_M	Toner density sensor [Magnetic sensor]	Detects the toner density (M)	–	–	CN15	A-7	PCU	Analog detection
TCS_Y	Toner density sensor [Magnetic sensor]	Detects the toner density (Y)	–	–	CN15	A-16	PCU	Analog detection
TFD2	Paper exit full detection [Transmission type]	Detects the face-down paper exit tray full.	Full	–	CN13	16	PCU	
TFD3	Right tray paper exit full detection	Detects paper exit full in the right tray.	Full	–	CN10	13	PCU	
TH_LM_IN	Lower thermistor	Detects the temperature.	–	–	CN17	B-6	PCU	Analog detection
TH_M	Temperature detection	Detects the temperature.	–	–	CN10	6	PCU	Analog detection
TH_UM_CS_IN	Main thermistor	Detects the temperature.	–	–	CN17	B-2	PCU	Analog detection
TH_UM_IN	Main thermistor	Detects the temperature.	–	–	CN17	B-1	PCU	Analog detection
TH_US_IN	Sub thermistor	Detects the temperature.	–	–	CN17	B-4	PCU	Analog detection
TH1_LSU	LSU unit thermistor	Detects the temperature.	–	–	CN2	A-2	PCU	Analog detection
TNFD	Waste toner full detection switch [Mechanical switch]	Detects waste toner full.	Empty	Full	CN9	10	PCU	
TNM_C	Toner motor C [Stepping motor]	Transports toner from the toner cartridge to the developing unit.	–	–	CN16	17, 18, 19, 20	PCU	Drives with the 4-phase signal.

Signal name	Name [Type]	Function/Operation	Connector level		Connector No.	Pin No.	PWB name	NOTE
			L	H				
TNM_K	Toner motor K [Stepping motor]	Transports toner from the toner cartridge to the developing unit.	–	–	CN16	25, 26, 27, 28	PCU	Drives with the 4-phase signal.
TNM_M	Toner motor M [Stepping motor]	Transports toner from the toner cartridge to the developing unit.	–	–	CN19	17, 19, 25, 27	PCU	Drives with the 4-phase signal.
TNM_Y	Toner motor Y [Stepping motor]	Transports toner from the toner cartridge to the developing unit.	–	–	CN19	5, 7, 13, 15	PCU	Drives with the 4-phase signal.

## B. 23cpm/31cpm(G) machine

Signal name	Name [Type]	Function/Operation	Connector level		Connector No.	Pin No.	PWB name	NOTE
			L	H				
1TUD_CL	Transfer belt separation CL detection	Detects the transfer belt separation CL.	–	–	CN18	1	PCU	
1TUD_K	Transfer belt separation BK detection	Detects the transfer belt separation BK.	–	–	CN18	2	PCU	
1TURC_1	Primary transfer separation clutch	Controls the primary transfer separation mode. [Electromagnetic clutch]	Separation select	–	CN16	7	PCU	
1TURC_2	Primary transfer separation clutch [Electromagnetic clutch]	Controls the primary transfer separation mode.	Separation select	–	CN16	8	PCU	
2TCCRU	Secondary transfer unit initial detection	Detects the initial state of the secondary transfer unit.	–	–	CN10	9	PCU	
2TUD	Secondary transfer position detection	Detects the position of the secondary transfer.	Separate	Contact	CN10	5	PCU	
2TURC	Secondary transfer separation clutch [Electromagnetic clutch]	Controls the secondary transfer separation mode.	Separation select	–	CN10	7	PCU	
ADUGS	ADU gate solenoid	Controls the ADU gate solenoid.	ON	OFF	CN10	18	PCU	
ADUM	ADU motor		–	–	CN11	23, 25, 26	PCU	
ADUM_CNT	ADU motor current select	ADU motor lower current select	Current Large	Current Small	CN11	24	PCU	
APPD1	ADU transport path detection 1 [Transmission type]	Detects paper pass in the ADU upper stream section.	Pass	–	CN10	14	PCU	
APPD2	ADU transport path detection 2 [Transmission type]	ADU midstream paper pass detection	Pass	–	CN10	11	PCU	
CCFT	LCD backlight [CCFT cool cathode ray tube]	LCD backlight	ON	OFF	CN4	21	SCNcnt	
CL_ON	Scanner lamp	Radiates light onto a document for the CCD to scan the document image.	ON	OFF	CN8	3	SCNcnt	
CLUD1	Tray 1 upper limit detection (Lift HP detection) [Transmission type]	Detects the tray 1 upper limit.	–	Upper limit	CN9	23	PCU	
CLUD2	Tray 2 upper limit detection (Lift HP detection) [Transmission type]	Detects the tray 2 upper limit.	–	Upper limit	CN8	11	PCU	
CLUM1	Paper tray lift-up motor (Paper feed tray 1) [DC brush motor]	Drives the paper tray lift plate.	Stop	Drive	CN9	20	PCU	
CLUM2	Paper tray lift-up motor (Paper feed tray 2) [DC brush motor]	Drives the paper tray lift plate.	Stop	Drive	CN8	8	PCU	
CPED1	Tray 1 paper empty detection [Transmission type]	Detects paper empty in the tray 1.	YES	NO	CN9	25	PCU	
CPED2	Tray 2 paper empty detection [Transmission type]	Detects paper empty in the tray 2.	YES	NO	CN8	13	PCU	
CPFC1	Tray vertical transport clutch 1 [Electromagnetic clutch]	Controls ON/OFF of the paper transport roller in the paper feed tray section.	ON	OFF	CN11	17	PCU	
CPFC2	Tray vertical transport clutch 2 [Electromagnetic clutch]	Controls ON/OFF of the paper transport roller in the paper feed tray section.	ON	OFF	CN8	2	PCU	
CPFD1	Tray 1 transport detection (Paper entry detection) [Transmission type]	Detects paper pass in the tray 1.	Pass	–	CN9	27	PCU	
CPFD2	Tray 2 transport detection (Paper entry detection) [Transmission type]	Detects paper pass in the tray 2.	Pass	–	CN8	15	PCU	

Signal name	Name [Type]	Function/Operation	Connector level		Connector No.	Pin No.	PWB name	NOTE
			L	H				
CPFM_D	Paper feed motor [Brushless motor]	Drives the paper feed section.	Drive	Stop	CN12	24	PCU	
CPFM_LD	Paper feed motor lock detection	Detects the paper feed motor lock.	–	Lock detection	CN12	28	PCU	
CPUC1	Paper feed clutch (Paper feed tray 1) [Electromagnetic clutch]	Controls ON/OFF of the roller in the paper feed tray section.	ON	OFF	CN11	18	PCU	
CPUC2	Paper feed clutch (Paper feed tray 2) [Electromagnetic clutch]	Controls ON/OFF of the roller in the paper feed tray section.	ON	OFF	CN8	1	PCU	
CPUS1	Paper feed pickup solenoid (Paper feed tray 2) [Solenoid]	Controls the paper pickup solenoid.	ON	OFF	CN9	17	PCU	
CPUS2	Paper feed pickup solenoid (Paper feed tray 2) [Solenoid]	Controls the paper pickup solenoid.	ON	OFF	CN8	5	PCU	
CSPD1	Tray 1 remaining paper quantity detection	Detects the remaining paper quantity in the tray 1.	Remaining quantity	–	CN9	32	PCU	Detects during lifting up.
CSPD2	Tray 2 remaining paper quantity detection	Detects the remaining paper quantity in the tray 2.	Remaining quantity	–	CN8	20	PCU	Detects during lifting up.
CSS11	Tray 1 detection	Detects the tray 1.	YES	NO	CN9	24	PCU	
CSS21	Tray 2 detection	Detects the tray 2.	YES	NO	CN8	12	PCU	
CSS2SET	Cassette 2 unit detection	Detects the cassette 2 unit.	YES	NO	CN8	22	PCU	
DHPD_CL	CL phase detection	Detects the CL phase.	Reference	–	CN16	2	PCU	
DHPD_K	BK phase detection	Detects the BK phase.	Reference	–	CN16	1	PCU	
DL_BK	Discharge lamp BK [LED]	Discharges electric charges on the OPC drum.	OFF	ON	CN14	8	PCU	
DL_C	Discharge lamp C [LED]	Discharges electric charges on the OPC drum.	OFF	ON	CN14	4	PCU	
DL_M	Discharge lamp M [LED]	Discharges electric charges on the OPC drum.	OFF	ON	CN14	7	PCU	
DL_Y	Discharge lamp Y [LED]	Discharges electric charges on the OPC drum.	OFF	ON	CN14	3	PCU	
DSW_ADU	ADU transport open/close detection [Transmission type]	Detects ADU cover open/close.	Open	Close	CN10	12	PCU	
DSW_C1	Tray 1 transport cover open/close detection	Detects tray 1 transport cover open/close.	Open	Close	CN9	31	PCU	
DSW_C2	Tray 2 transport cover open/close detection	Detects tray 2 transport cover open/close.	Open	Close	CN8	19	PCU	
DSW_F	Front door open/close switch [Micro switch]	Detects open/close of the front door, and fusing, motor, LSU laser power line.	Open	Close	CN11	12	PCU	
DSW_R	Right door open/close switch [Micro switch]	Detects open/close of the right door unit, and fusing, motor, LSU laser power line.	Open	Close	CN11	10	PCU	
DVM_CL_D	Development drive motor (CL) [Brushless motor]	Drives the development section, the color OPC drum, and the transfer section.	Drive	Stop	CN16	14	PCU	
DVM_CL_LD	Development drive motor (CL) lock detection	Detects the development drive motor (CL) lock.	–	Lock detection	CN16	16	PCU	
DVM_K_D	Development drive motor (K) [Brushless motor]	Drives the development section, the black OPC drum, and the transfer section.	Drive	Stop	CN16	13	PCU	
DVM_K_LD	Development drive motor (K) lock detection	Detects the development drive motor (K) lock.	–	Lock detection	CN16	15	PCU	
FUFM_LD	Fusing fan motor lock detection	Detects the fusing fan motor lock.	–	Lock detection	CN12	25	PCU	
FUFM_V	Fusing fan motor	Cools the motor related to the fusing and the paper exit sections.	OFF	ON	CN12	19	PCU	
FUM_D	Fusing drive motor [Brushless motor]	Drives the fusing unit.	Drive	Stop	CN13	17	PCU	
FUM_LD	Fusing drive motor lock detection	Detects the fusing drive motor lock.	–	Lock detection	CN13	19	PCU	
HL_LM_out	Lower heater lamp	Turns ON/OFF the lower heater lamp.	OFF	ON	CN13	13	PCU	
HL_PR	Heater lamp power relay	Heater lamp power line ON/OFF	OFF (Open)	ON (Close)	CN19	26	PCU	
HL_UM_out	Heater lamp main	Turns ON/OFF the heater lamp main.	OFF	ON	CN13	9	PCU	
HL_US_out	Heater lamp sub	Turns ON/OFF the heater lamp sub.	OFF	ON	CN13	11	PCU	
HLPCD	Fusing pressure detection sensor [Transmission sensor]	Detects a change in the fusing pressure.	Pressure release	Pressure applying	CN13	3	PCU	
HPOS (SHPOS)	Shifter home position sensor	Detects the shifter home position.	–	Home position	CN13	22	PCU	



Signal name	Name [Type]	Function/Operation	Connector level		Connector No.	Pin No.	PWB name	NOTE
			L	H				
HUD_M	Humidity detection	Detects the humidity.	-	-	CN10	4	PCU	Analog detection
INT_CNT	Interlock control	ON/OFF control of INT24V1,V2	ON	OFF	CN11	14	PCU	
MHPS	Scanner home position sensor [Transmission type]	Detects the scanner home position.	-	Home	CN10	1	SCNcnt	
MIM_*	Scanner motor [Stepping motor]	Scanner (reading) section	-	-	CN7	1, 2, 3, 4	SCNcnt	
MPED	Manual feed paper empty detection [Transmission type]	Detects paper empty in the manual paper feed tray.	YES	NO	CN10	1	PCU	
MPFS	Paper pickup solenoid (Manual paper feed) [Electromagnetic solenoid]	Paper pickup solenoid (Manual paper feed) [Electromagnetic solenoid]	Pickup	-	CN10	3	PCU	
MPLD	Manual feed paper length detector	Detects the paper length in the manual paper feed tray.	-	Detection	CN10	10	PCU	
MPWS	Manual feed tray paper width sensor	Detects the paper width in the manual feed tray.	-	-	CN10	8	PCU	
OCSW	Light emitting unit open/close detector	Detects the light emitting unit open/close.	Close	Open	CN17	3	SCNcnt	
OSM	Shifter motor [Stepping motor]	Offsets the paper.	-	-	CN12	7, 8, 9, 10	PCU	Drives with the 4-phase signal.
PFC_HPFC	PS front clutch	Controls the PS front clutch.	ON	OFF	CN11	22	PCU	
PFM	Transport motor		-	-	CN11	30, 32, 34	PCU	
PFM_CNT	Transport motor current select	Selects the transport motor current.	Current Large	Current Small	CN11	28	PCU	
POD1	Fusing rear detection [Transmission type]	Detects the paper exit from fusing.	Pass	-	CN13	4	PCU	
POD2	Paper exit detection [Transmission type]	Detects the discharged paper.	Pass	-	CN13	10	PCU	
POD3	Right tray paper exit detection	Detects paper exit to the right tray.	Pass	-	CN10	16	PCU	
POFM_CNT	Paper exit cooling fan motor speed control	Controls the speed of the paper exit cooling fan motor.	-	-	CN12	13, 14	PCU	Pulse (Duty) drive
POFM_LD1	POFM lock detection	Detects the POFM lock.	-	Lock detection	CN12	17	PCU	
POFM_LD2	POFM lock detection	Detects the POFM lock.	-	Lock detection	CN12	18	PCU	
POFM_V	Paper exit cooling fan motor	Cools the fusing unit.	Stop	Drive	CN12	11,12	PCU	
POM	Paper exit drive motor	Drives the paper exit roller.	-	-	CN11	5, 7, 9, 11	PCU	
POM_CNT	Paper exit drive motor current select	Selects the paper exit drive motor current.	Current Large	Current Small	CN11	13	PCU	
PPD1	Registration front detection [Transmission type]	Detects paper in front of the registration roller.	Pass	-	CN9	14	PCU	
PPD2	Registration detection	Detects paper at the rear of the registration roller.	Pass	-	CN9	16	PCU	
PRM	Fusing pressure release motor [Stepping motor]	Changes the fusing voltage.	-	-	CN12	1, 2, 3, 4	PCU	Drives with the 4-phase signal.
PROFM1_CNT	Process fan motor 2 speed control	Controls the speed of the process fan motor.	-	-	CN19	29	PCU	
PROFM1_LD	Process fan motor 2 lock detection	Process fan motor lock detection	-	Lock detection	CN19	22	PCU	
PROFM1_V	Process fan motor 2	Cools the process.	OFF	ON	CN19	33	PCU	
PROFM2_CNT	Process fan motor 2 speed control	Controls the speed of the process fan motor 2.	-	-	CN9	4	PCU	Pulse (Duty) drive
PROFM2_LD	Process fan motor 2 lock detection	Detects process fan motor 2 lock.	-	Lock detection	CN9	8	PCU	
PROFM2_V	Process fan motor 2	Cools the process.	OFF	ON	CN9	2	PCU	
PRTPD	Right paper exit tray paper empty detection	Detects paper empty in the right paper exit tray.	NO	YES	CN10	15	PCU	
PSFM_LD	Power cooling fan motor lock detection	Detects the power cooling fan motor lock.	-	Lock detection	CN19	30	PCU	
PSFM_V	Power cooling fan motor	Cools the power unit.	Stop	Drive	CN19	28	PCU	
REGS_F	Registration sensor (Front) [Reflection type]	Registration shift detection	-	-	CN17	A-2	PCU	Analog detection
REGS_F_LED	Registration sensor LED (Front) [LED]	Registration sensor LED light emitting	-	-	CN17	A-3	PCU	Analog output
REGS_R	Registration sensor (Rear) [Reflection type]	Registration shift detection	-	-	CN17	A-6	PCU	Analog detection
REGS_R_LED	Registration sensor LED (Rear) [LED]	Registration sensor LED light emitting	-	-	CN17	A-7	PCU	Analog output

Signal name	Name [Type]	Function/Operation	Connector level		Connector No.	Pin No.	PWB name	NOTE
			L	H				
RRM	Registration motor		–	–	CN11	31, 33	PCU	
RRM_CNT	Registration motor current select	Selects the registration motor current.	Current Large	Current Small	CN11	27	PCU	
S OCD	SPF open/close sensor	Detects open/close of the SPF.	Close	–	CN14	28	SCNcnt	
SPED	Document empty sensor	Detects document empty.	Detection	–	CN14	27	SCNcnt	
SPFM*	SPF transport motor	Drives the SPF transport motor.	–	–	CN14	3, 4, 5, 6, 7	SCNcnt	
SPM*	SPF paper feed motor	Drives the SPF paper feed motor.	–	–	CN14	8, 9, 10, 11, 12	SCNcnt	
SPPD1	SPF transport sensor 1	Detects paper pass.	Detection	–	CN14	1	SCNcnt	
SPPD2	SPF transport sensor 2	Detects paper pass.	Detection	–	CN14	2	SCNcnt	
SPPD3	SPF transport sensor 3	Detects paper pass.	Detection	–	CN14	24	SCNcnt	
SPPD4	SPF transport sensor 4	Detects paper pass.	Detection	–	CN14	22	SCNcnt	
SPRS	Pressure release solenoid	Controls the pressure release solenoid.	OFF	ON	CN14	13	SCNcnt	
SPWS	Document width sensor	Detects document width.	–	–	CN14	17	SCNcnt	
SRRC	PS clutch	Controls the PS clutch.	OFF	ON	CN14	15	SCNcnt	
STMPS	Stamp solenoid	Controls the stamp solenoid.	–	Stamp	CN14	14	SCNcnt	
TCS_C	Toner density sensor [Magnetic sensor]	Detects the toner density (C)	–	–	CN15	B-7	PCU	Analog detection
TCS_K	Toner density sensor [Magnetic sensor]	Detects the toner density (K)	–	–	CN15	B-16	PCU	Analog detection
TCS_M	Toner density sensor [Magnetic sensor]	Detects the toner density (M)	–	–	CN15	A-7	PCU	Analog detection
TCS_Y	Toner density sensor [Magnetic sensor]	Detects the toner density (Y)	–	–	CN15	A-16	PCU	Analog detection
TFD2	Paper exit full detection [Transmission type]	Detects the face-down paper exit tray full.	Full	–	CN13	16	PCU	
TFD3	Right tray paper exit full detection	Detects paper exit full in the right tray.	Full	–	CN10	13	PCU	
TH_LM_IN	Lower thermistor	Detects the temperature.	–	–	CN17	B-11	PCU	Analog detection
TH_M	Temperature detection	Detects the temperature.	–	–	CN10	6	PCU	Analog detection
TH_UM_CS_IN	Main thermistor	Detects the temperature.	–	–	CN17	B-7	PCU	Analog detection
TH_UM_IN	Main thermistor	Detects the temperature.	–	–	CN17	B-6	PCU	Analog detection
TH_US_IN	Sub thermistor	Detects the temperature.	–	–	CN17	B-9	PCU	Analog detection
TH1_LSU	LSU unit thermistor	Detects the temperature.	–	–	CN2	A-2	PCU	Analog detection
TNFD	Waste toner full detection switch [Mechanical switch]	Detects waste toner full.	Empty	Full	CN9	10	PCU	
TNM_C	Toner motor C [Stepping motor]	Transports toner from the toner cartridge to the developing unit.	–	–	CN16	17, 18, 19, 20	PCU	Drives with the 4-phase signal.
TNM_K	Toner motor K [Stepping motor]	Transports toner from the toner cartridge to the developing unit.	–	–	CN16	25, 26, 27, 28	PCU	Drives with the 4-phase signal.
TNM_M	Toner motor M [Stepping motor]	Transports toner from the toner cartridge to the developing unit.	–	–	CN19	17, 19, 25, 27	PCU	Drives with the 4-phase signal.
TNM_Y	Toner motor Y [Stepping motor]	Transports toner from the toner cartridge to the developing unit.	–	–	CN19	5, 7, 13, 15	PCU	Drives with the 4-phase signal.

### C. 26cpm/31cpm(A) machine

Signal name	Name [Type]	Function/Operation	Connector level		Connector No.	Pin No.	PWB name	NOTE
			L	H				
1TUD_CL	Transfer belt separation CL detection	Detects the transfer belt separation CL.	–	–	CN18	1	PCU	
1TUD_K	Transfer belt separation BK detection	Detects the transfer belt separation BK.	–	–	CN18	2	PCU	
1TURC_1	Primary transfer separation clutch [Electromagnetic clutch]	Controls the primary transfer separation mode.	Separation select	–	CN16	7	PCU	
1TURC_2	Primary transfer separation clutch [Electromagnetic clutch]	Controls the primary transfer separation mode.	Separation select	–	CN16	8	PCU	
2TCCRU	Secondary transfer unit initial detection	Detects the initial state of the secondary transfer unit.	–	–	CN10	9	PCU	

Signal name	Name [Type]	Function/Operation	Connector level		Connector No.	Pin No.	PWB name	NOTE
			L	H				
2TUD	Secondary transfer position detection	Detects the position of the secondary transfer.	Separate	Contact	CN10	5	PCU	
2TURC	Secondary transfer separation clutch [Electromagnetic clutch]	Controls the secondary transfer separation mode.	Separation select	–	CN10	7	PCU	
ADUM	ADU motor		–	–	CN11	23, 25, 26	PCU	
ADUM_CNT	ADU motor current select	ADU motor lower current select	Current Large	Current Small	CN11	24	PCU	
APPD1	ADU transport path detection 1 [Transmission type]	Detects paper pass in the ADU upper stream section.	Pass	–	CN10	14	PCU	
APPD2	ADU transport path detection 2 [Transmission type]	ADU midstream paper pass detection	Pass	–	CN10	11	PCU	
/CCFT	LCD backlight	Backlight for LCD	ON	OFF	CN4	21	SCNcnt	
CLUD1	Tray 1 upper limit detection (Lift HP detection) [Transmission type]	Detects the tray 1 upper limit.	–	Upper limit	CN9	23	PCU	
CLUD2	Tray 2 upper limit detection (Lift HP detection) [Transmission type]	Detects the tray 2 upper limit.	–	Upper limit	CN8	11	PCU	
CLUM1	Paper tray lift-up motor (Paper feed tray 1) [DC brush motor]	Drives the paper tray lift plate.	Stop	Drive	CN9	20	PCU	
CLUM2	Paper tray lift-up motor (Paper feed tray 2) [DC brush motor]	Drives the paper tray lift plate.	Stop	Drive	CN8	8	PCU	
CPED1	Tray 1 paper empty detection [Transmission type]	Detects paper empty in the tray 1.	YES	NO	CN9	25	PCU	
CPED2	Tray 2 paper empty detection [Transmission type]	Detects paper empty in the tray 2.	YES	NO	CN8	13	PCU	
CPFC1	Tray vertical transport clutch 1 [Electromagnetic clutch]	Controls ON/OFF of the paper transport roller in the paper feed tray section.	ON	OFF	CN11	17	PCU	
CPFC2	Tray vertical transport clutch 2 [Electromagnetic clutch]	Controls ON/OFF of the paper transport roller in the paper feed tray section.	ON	OFF	CN8	2	PCU	
CPFD1	Tray 1 transport detection (Paper entry detection) [Transmission type]	Detects paper pass in the tray 1.	Pass	–	CN9	27	PCU	
CPFD2	Tray 2 transport detection (Paper entry detection) [Transmission type]	Detects paper pass in the tray 2.	Pass	–	CN8	15	PCU	
CPFM_D	Paper feed motor [Brushless motor]	Drives the paper feed section.	Drive	Stop	CN12	24	PCU	
CPFM_LD	Paper feed motor lock detection	Detects the paper feed motor lock.	–	Lock detection	CN12	28	PCU	
CPUC1	Paper feed clutch (Paper feed tray 1) [Electromagnetic clutch]	Controls ON/OFF of the roller in the paper feed tray section.	ON	OFF	CN11	18	PCU	
CPUC2	Paper feed clutch (Paper feed tray 2) [Electromagnetic clutch]	Controls ON/OFF of the roller in the paper feed tray section.	ON	OFF	CN8	1	PCU	
CPUS1	Paper feed pickup solenoid (Paper feed tray 2) [Solenoid]	Controls the paper pickup solenoid.	ON	OFF	CN9	17	PCU	
CPUS2	Paper feed pickup solenoid (Paper feed tray 2) [Solenoid]	Controls the paper pickup solenoid.	ON	OFF	CN8	5	PCU	
CSPD1	Tray 1 remaining paper quantity detection	Detects the remaining paper quantity in the tray 1.	Remaining quantity	–	CN9	32	PCU	Detects during lifting up.
CSPD2	Tray 2 remaining paper quantity detection	Detects the remaining paper quantity in the tray 2.	Remaining quantity	–	CN8	20	PCU	Detects during lifting up.
CSS11	Tray 1 detection	Detects the tray 1.	YES	NO	CN9	24	PCU	
CSS21	Tray 2 detection	Detects the tray 2.	YES	NO	CN8	12	PCU	
CSS2SET	Cassette 2 unit detection	Detects the cassette 2 unit.	YES	NO	CN8	22	PCU	
DHPD_CL	CL phase detection	Detects the CL phase.	Reference	–	CN16	2	PCU	
DHPD_K	BK phase detection	Detects the BK phase.	Reference	–	CN16	1	PCU	
DL_BK	Discharge lamp BK [LED]	Discharges electric charges on the OPC drum.	OFF	ON	CN14	8	PCU	
DL_C	Discharge lamp C [LED]	Discharges electric charges on the OPC drum.	OFF	ON	CN14	4	PCU	
DL_M	Discharge lamp M [LED]	Discharges electric charges on the OPC drum.	OFF	ON	CN14	7	PCU	
DL_Y	Discharge lamp Y [LED]	Discharges electric charges on the OPC drum.	OFF	ON	CN14	3	PCU	
DSW_ADU	ADU transport open/close detection [Transmission type]	Detects ADU cover open/close.	Open	Close	CN10	12	PCU	
DSW_C1	Tray 1 transport cover open/close detection	Detects tray 1 transport cover open/close.	Open	Close	CN9	31	PCU	

Signal name	Name [Type]	Function/Operation	Connector level		Connector No.	Pin No.	PWB name	NOTE
			L	H				
DSW_C2	Tray 2 transport cover open/close detection	Detects tray 2 transport cover open/close.	Open	Close	CN8	19	PCU	
DSW_F	Front door open/close switch [Micro switch]	Detects open/close of the front door, and fusing, motor, LSU laser power line.	Open	Close	CN11	12	PCU	
DSW_R	Right door open/close switch [Micro switch]	Detects open/close of the right door unit, and fusing, motor, LSU laser power line.	Open	Close	CN11	10	PCU	
DVM_CL_D	Development drive motor (CL) [Brushless motor]	Drives the development section, the color OPC drum, and the transfer section.	Drive	Stop	CN16	14	PCU	
DVM_CL_LD	Development drive motor (CL) lock detection	Detects the development drive motor (CL) lock.	–	Lock detection	CN16	16	PCU	
DVM_K_D	Development drive motor (K) [Brushless motor]	Drives the development section, the black OPC drum, and the transfer section.	Drive	Stop	CN16	13	PCU	
DVM_K_LD	Development drive motor (K) lock detection	Detects the development drive motor (K) lock.	–	Lock detection	CN16	15	PCU	
FUFM_LD	Fusing fan motor lock detection	Detects the fusing fan motor lock.	–	Lock detection	CN12	25	PCU	
FUFM_V	Fusing fan motor	Cools the motor related to the fusing and the paper exit sections.	OFF	ON	CN12	19	PCU	
FUM_D	Fusing drive motor [Brushless motor]	Drives the fusing unit.	Drive	Stop	CN13	17	PCU	
FUM_LD	Fusing drive motor lock detection	Detects the fusing drive motor lock.	–	Lock detection	CN13	19	PCU	
HL_LM_out	Lower heater lamp	Turns ON/OFF the lower heater lamp.	OFF	ON	CN13	13	PCU	
HL_UM_out	Heater lamp main	Turns ON/OFF the heater lamp main.	OFF	ON	CN13	9	PCU	
HL_US_out	Heater lamp sub	Turns ON/OFF the heater lamp sub.	OFF	ON	CN13	11	PCU	
HLPCD	Fusing pressure detection sensor [Transmission sensor]	Detects a change in the fusing pressure.	Pressure release	Pressure applying	CN13	3	PCU	
HUD_M	Humidity detection	Detects the humidity.	–	–	CN10	4	PCU	Analog detection
INT_CNT	Interlock control	ON/OFF control of INT24V1,V2	ON	OFF	CN11	14	PCU	
LAMP	Scanner lamp	Radiates light onto a document for the CCD to scan the document image.	ON	OFF	CN8	3	SCNcnt	
MHPS	Scanner home position sensor	Detects the scanner home position.		Home position	CN10	1	SCNcnt	
MIM_*	Scanner motor	Scanner (reading) section			CN7	1, 2, 3, 4	SCNcnt	
MPED	Manual feed paper empty detection [Transmission type]	Detects paper empty in the manual paper feed tray.	YES	NO	CN10	1	PCU	
MPFS	Paper pickup solenoid (Manual paper feed) [Electromagnetic solenoid]	Paper pickup solenoid (Manual paper feed) [Electromagnetic solenoid]	Pickup	–	CN10	3	PCU	
MPLD	Manual feed paper length detector	Detects the paper length in the manual paper feed tray.	–	Detection	CN10	10	PCU	
MPWS	Manual feed tray paper width sensor	Detects the paper width in the manual feed tray.	–	–	CN10	8	PCU	
nBD	LSU synchronization detection signal (BD signal)	Detects synchronization of the LSU in the main scanning direction.	Detection	–	CN500	62	LSU-Mother	
nOFF_CNT	+5VL power OFF signal	Turns OFF the +5VL power.	Turned ON	Turned OFF	CN14	2	LSU-Mother	Only 5VO is ON.
nPOLY_CK	Polygon motor clock signal	Controls the speed of the polygon motor.	–	–	CN500	28	LSU-Mother	
nPOLY_LOCK	Polygon motor lock signal	Detects the polygon motor lock.	–	Lock detection	CN500	29	LSU-Mother	Pulse (Duty) drive
nPOLY_START	Polygon motor ON signal	Drives the polygon motor of the LSU unit.	Drive	Stop	CN500	30	LSU-Mother	
nPOW_LED	Main power LED signal	Checks that the main power source is ON.	Green lighting	Orange lighting	CN10	6	LSU-Mother	
nPWRSW	Power switch signal	Detects ON/OFF of the power.	Detection	–	CN10	1	LSU-Mother	
nRY_CNT	Main system power OFF signal	Turns OFF the power other than +5VO and +5VL.	Turned ON	Turned OFF	CN14	1	LSU-Mother	Only 5VL_5VO is ON.

Signal name	Name [Type]	Function/Operation	Connector level		Connector No.	Pin No.	PWB name	NOTE
			L	H				
nWU_KEY	Energy saving switch signal	Shifts to the energy save mode.	Detection	–	CN10	2	LSU-Mother	
nWU_LED	Energy saving LED signal	Checks that the machine is shifted to the energy save mode.	ON	OFF	CN10	8	LSU-Mother	Pulse (Duty) drive
OSM	Shifter motor [Stepping motor]	Offsets the paper.	–	–	CN12	7, 8, 9, 10	PCU	Drives with the 4-phase signal.
PFC_HPFC	PS front clutch	Controls the PS front clutch.	ON	OFF	CN11	22	PCU	
PFM	Transport motor		–	–	CN11	30, 32, 34	PCU	
PFM_CNT	Transport motor current select	Selects the transport motor current.	Current Large	Current Small	CN11	28	PCU	
POD1	Fusing rear detection [Transmission type]	Detects the paper exit from fusing.	Pass	–	CN13	4	PCU	
POD2	Paper exit detection [Transmission type]	Detects the discharged paper.	Pass	–	CN13	10	PCU	
POD3	Right tray paper exit detection	Detects paper exit to the right tray.	Pass	–	CN10	16	PCU	
POFM_CNT	Paper exit cooling fan motor speed control	Controls the speed of the paper exit cooling fan motor.	–	–	CN12	13, 14	PCU	Pulse (Duty) drive
POFM_LD1	POFM lock detection	Detects the POFM lock.	–	Lock detection	CN12	17	PCU	
POFM_LD2	POFM lock detection	Detects the POFM lock.	–	Lock detection	CN12	18	PCU	
POFM_V	Paper exit cooling fan motor	Cools the fusing unit.	Stop	Drive	CN12	11, 12	PCU	
POM	Paper exit drive motor	Drives the paper exit roller.	–	–	CN11	5, 7, 9, 11	PCU	
POM_CNT	Paper exit drive motor current select	Selects the paper exit drive motor current.	Current Large	Current Small	CN11	13	PCU	
PPD1	Registration front detection [Transmission type]	Detects paper in front of the registration roller.	Pass	–	CN9	14	PCU	
PPD2	Registration detection	Detects paper at the rear of the registration roller.	Pass	–	CN9	16	PCU	
PRM	Fusing pressure release motor [Stepping motor]	Changes the fusing voltage.	–	–	CN12	1, 2, 3, 4	PCU	Drives with the 4-phase signal.
PROFM1_CNT	Process fan motor 2 speed control	Controls the speed of the process fan motor.	–	–	CN19	29	PCU	
PROFM1_LD	Process fan motor 2 lock detection	Process fan motor lock detection	–	Lock detection	CN19	22	PCU	
PROFM1_V	Process fan motor 2	Cools the process.	OFF	ON	CN19	33	PCU	
PROFM2_CNT	Process fan motor 2 speed control	Controls the speed of the process fan motor 2.	–	–	CN9	4	PCU	Pulse (Duty) drive
PROFM2_LD	Process fan motor 2 lock detection	Detects process fan motor 2 lock.	–	Lock detection	CN9	8	PCU	
PROFM2_V	Process fan motor 2	Cools the process.	OFF	ON	CN9	2	PCU	
PRTPD	Right paper exit tray paper empty detection	Detects paper empty in the right paper exit tray.	NO	YES	CN10	15	PCU	
PSFM_LD	Power cooling fan motor lock detection	Detects the power cooling fan motor lock.	–	Lock detection	CN19	30	PCU	
PSFM_V	Power cooling fan motor	Cools the power unit.	Stop	Drive	CN19	28	PCU	
REGS_F	Registration sensor (Front) [Reflection type]	Registration shift detection	–	–	CN17	A-2	PCU	Analog detection
REGS_F_LED	Registration sensor LED (Front) [LED]	Registration sensor LED light emitting	–	–	CN17	A-3	PCU	Analog output
REGS_R	Registration sensor (Rear) [Reflection type]	Registration shift detection	–	–	CN17	A-6	PCU	Analog detection
REGS_R_LED	Registration sensor LED (Rear) [LED]	Registration sensor LED light emitting	–	–	CN17	A-7	PCU	Analog output
RRM	Registration motor		–	–	CN11	31, 33	PCU	
RRM_CNT	Registration motor current select	Selects the registration motor current.	Current Large	Current Small	CN11	27	PCU	
SHPOS	Shifter home position sensor	Detects the shifter home position.	–	Home position	CN13	22	PCU	
TCS_C	Toner density sensor [Magnetic sensor]	Detects the toner density (C)	–	–	CN15	B-7	PCU	Analog detection
TCS_K	Toner density sensor [Magnetic sensor]	Detects the toner density (K)	–	–	CN15	B-16	PCU	Analog detection
TCS_M	Toner density sensor [Magnetic sensor]	Detects the toner density (M)	–	–	CN15	A-7	PCU	Analog detection
TCS_Y	Toner density sensor [Magnetic sensor]	Detects the toner density (Y)	–	–	CN15	A-16	PCU	Analog detection

Signal name	Name [Type]	Function/Operation	Connector level		Connector No.	Pin No.	PWB name	NOTE
			L	H				
TFD2	Paper exit full detection [Transmission type]	Detects the face-down paper exit tray full.	Full	–	CN13	16	PCU	
TFD3	Right tray paper exit full detection	Detects paper exit full in the right tray.	Full	–	CN10	13	PCU	
TH_LM_IN	Lower thermistor	Detects the temperature.	–	–	CN17	B-11	PCU	Analog detection
TH_M	Temperature detection	Detects the temperature.	–	–	CN10	6	PCU	Analog detection
TH_UM_CS_IN	Main thermistor	Detects the temperature.	–	–	CN17	B-7	PCU	Analog detection
TH_UM_IN	Main thermistor	Detects the temperature.	–	–	CN17	B-6	PCU	Analog detection
TH_US_IN	Sub thermistor	Detects the temperature.	–	–	CN17	B-9	PCU	Analog detection
TH1_LSU	LSU unit thermistor	Detects the temperature.	–	–	CN2	A-2	PCU	Analog detection
TNFD	Waste toner full detection switch [Mechanical switch]	Detects waste toner full.	Empty	Full	CN9	10	PCU	
TNM_C	Toner motor C [Stepping motor]	Transports toner from the toner cartridge to the developing unit.	–	–	CN16	17, 18, 19, 20	PCU	Drives with the 4-phase signal.
TNM_K	Toner motor K [Stepping motor]	Transports toner from the toner cartridge to the developing unit.	–	–	CN16	25, 26, 27, 28	PCU	Drives with the 4-phase signal.
TNM_M	Toner motor M [Stepping motor]	Transports toner from the toner cartridge to the developing unit.	–	–	CN19	17, 19, 25, 27	PCU	Drives with the 4-phase signal.
TNM_Y	Toner motor Y [Stepping motor]	Transports toner from the toner cartridge to the developing unit.	–	–	CN19	5, 7, 13, 15	PCU	Drives with the 4-phase signal.

#### D. 36cpm machine

Signal name	Name [Type]	Function/Operation	Connector level		Connector No.	Pin No.	PWB name	NOTE
			L	H				
1TUD_CL	Transfer belt separation CL detection	Detects the transfer belt separation CL.	–	–	CN18	1	PCU	
1TUD_K	Transfer belt separation BK detection	Detects the transfer belt separation BK.	–	–	CN18	2	PCU	
1TURC_1	Primary transfer separation clutch [Electromagnetic clutch]	Controls the primary transfer separation mode.	Separation select	–	CN16	7	PCU	
1TURC_2	Primary transfer separation clutch [Electromagnetic clutch]	Controls the primary transfer separation mode.	Separation select	–	CN16	8	PCU	
2TCCRU	Secondary transfer unit initial detection	Detects the initial state of the secondary transfer unit.	–	–	CN10	9	PCU	
2TUD	Secondary transfer position detection	Detects the position of the secondary transfer.	Separate	Contact	CN10	5	PCU	
2TURC	Secondary transfer separation clutch [Electromagnetic clutch]	Controls the secondary transfer separation mode.	Separation select	–	CN10	7	PCU	
ADUGS	ADU gate solenoid	Controls the ADU gate solenoid.	ON	OFF	CN10	18	PCU	
ADUM	ADU motor		–	–	CN11	23, 25, 26	PCU	
ADUM_CNT	ADU motor current select	ADU motor lower current select	Current Large	Current Small	CN11	24	PCU	
APPD1	ADU transport path detection 1 [Transmission type]	Detects paper pass in the ADU upper stream section.	Pass	–	CN10	14	PCU	
APPD2	ADU transport path detection 2 [Transmission type]	ADU midstream paper pass detection	Pass	–	CN10	11	PCU	
BTM_CL_D	Primary transfer belt drive motor [Brushless motor]	Drives the primary transfer belt.	Drive	Stop	CN12	31	PCU	
BTM_CL_LD	Primary transfer belt drive motor lock detection	Detects the primary transfer belt drive motor lock.	–	Lock detection	CN12	30	PCU	
/CCFT	LCD backlight	Backlight for LCD	ON	OFF	CN4	21	SCNcnt	
CLUD1	Tray 1 upper limit detection (Lift HP detection) [Transmission type]	Detects the tray 1 upper limit.	–	Upper limit	CN9	23	PCU	
CLUD2	Tray 2 upper limit detection (Lift HP detection) [Transmission type]	Detects the tray 2 upper limit.	–	Upper limit	CN8	11	PCU	
CLUM1	Paper tray lift-up motor (Paper feed tray 1) [DC brush motor]	Drives the paper tray lift plate.	Stop	Drive	CN9	20	PCU	

Signal name	Name [Type]	Function/Operation	Connector level		Connector No.	Pin No.	PWB name	NOTE
			L	H				
CLUM2	Paper tray lift-up motor (Paper feed tray 2) [DC brush motor]	Drives the paper tray lift plate.	Stop	Drive	CN8	8	PCU	
CPED1	Tray 1 paper empty detection [Transmission type]	Detects paper empty in the tray 1.	YES	NO	CN9	25	PCU	
CPED2	Tray 2 paper empty detection [Transmission type]	Detects paper empty in the tray 2.	YES	NO	CN8	13	PCU	
CPFC1	Tray vertical transport clutch 1 [Electromagnetic clutch]	Controls ON/OFF of the paper transport roller in the paper feed tray section.	ON	OFF	CN11	17	PCU	
CPFC2	Tray vertical transport clutch 2 [Electromagnetic clutch]	Controls ON/OFF of the paper transport roller in the paper feed tray section.	ON	OFF	CN8	2	PCU	
CPFD1	Tray 1 transport detection (Paper entry detection) [Transmission type]	Detects paper pass in the tray 1.	Pass	–	CN9	27	PCU	
CPFD2	Tray 2 transport detection (Paper entry detection) [Transmission type]	Detects paper pass in the tray 2.	Pass	–	CN8	15	PCU	
CPFM_D	Paper feed motor [Brushless motor]	Drives the paper feed section.	Drive	Stop	CN12	24	PCU	
CPFM_LD	Paper feed motor lock detection	Detects the paper feed motor lock.	–	Lock detection	CN12	28	PCU	
CPUC1	Paper feed clutch (Paper feed tray 1) [Electromagnetic clutch]	Controls ON/OFF of the roller in the paper feed tray section.	ON	OFF	CN11	18	PCU	
CPUC2	Paper feed clutch (Paper feed tray 2) [Electromagnetic clutch]	Controls ON/OFF of the roller in the paper feed tray section.	ON	OFF	CN8	1	PCU	
CPUS1	Paper feed pickup solenoid (Paper feed tray 2) [Solenoid]	Controls the paper pickup solenoid.	ON	OFF	CN9	17	PCU	
CPUS2	Paper feed pickup solenoid (Paper feed tray 2) [Solenoid]	Controls the paper pickup solenoid.	ON	OFF	CN8	5	PCU	
CSPD1	Tray 1 remaining paper quantity detection	Detects the remaining paper quantity in the tray 1.	Remaining quantity	–	CN9	32	PCU	Detects during lifting up.
CSPD2	Tray 2 remaining paper quantity detection	Detects the remaining paper quantity in the tray 2.	Remaining quantity	–	CN8	20	PCU	Detects during lifting up.
CSS11	Tray 1 detection	Detects the tray 1.	YES	NO	CN9	24	PCU	
CSS21	Tray 2 detection	Detects the tray 2.	YES	NO	CN8	12	PCU	
CSS2SET	Cassette 2 unit detection	Detects the cassette 2 unit.	YES	NO	CN8	22	PCU	
DHPD_CL	CL phase detection	Detects the CL phase.	Reference	–	CN16	2	PCU	
DHPD_K	BK phase detection	Detects the BK phase.	Reference	–	CN16	1	PCU	
DL_BK	Discharge lamp BK [LED]	Discharges electric charges on the OPC drum.	OFF	ON	CN14	8	PCU	
DL_C	Discharge lamp C [LED]	Discharges electric charges on the OPC drum.	OFF	ON	CN14	4	PCU	
DL_M	Discharge lamp M [LED]	Discharges electric charges on the OPC drum.	OFF	ON	CN14	7	PCU	
DL_Y	Discharge lamp Y [LED]	Discharges electric charges on the OPC drum.	OFF	ON	CN14	3	PCU	
DSW_ADU	ADU transport open/close detection [Transmission type]	Detects ADU cover open/close.	Open	Close	CN10	12	PCU	
DSW_C1	Tray 1 transport cover open/close detection	Detects tray 1 transport cover open/close.	Open	Close	CN9	31	PCU	
DSW_C2	Tray 2 transport cover open/close detection	Detects tray 2 transport cover open/close.	Open	Close	CN8	19	PCU	
DSW_F	Front door open/close switch [Micro switch]	Detects open/close of the front door, and fusing, motor, LSU laser power line.	Open	Close	CN11	12	PCU	
DSW_R	Right door open/close switch [Micro switch]	Detects open/close of the right door unit, and fusing, motor, LSU laser power line.	Open	Close	CN11	10	PCU	
DVM_CL_D	Development drive motor (CL) [Brushless motor]	Drives the development section, the color OPC drum, and the transfer section.	Drive	Stop	CN16	14	PCU	
DVM_CL_LD	Development drive motor (CL) lock detection	Detects the development drive motor (CL) lock.	–	Lock detection	CN16	16	PCU	
DVM_K_D	Development drive motor (K) [Brushless motor]	Drives the development section, the black OPC drum, and the transfer section.	Drive	Stop	CN16	13	PCU	
DVM_K_LD	Development drive motor (K) lock detection	Detects the development drive motor (K) lock.	–	Lock detection	CN16	15	PCU	
FAN_24V	LSU cooling fan (LSUFM) signal	Drives the cooling fan of the LSU unit.	Stop	Drive	CN500	39	LSU-Mother	

Signal name	Name [Type]	Function/Operation	Connector level		Connector No.	Pin No.	PWB name	NOTE
			L	H				
FAN_nREADY	LSU cooling fan (LSUFM) lock signal	Detects lock of the cooling fan of the LSU unit.	–	Lock detection	CN500	38	LSU-Mother	
FUFM_LD	Fusing fan motor lock detection	Detects the fusing fan motor lock.	–	Lock detection	CN12	25	PCU	
FUFM_V	Fusing fan motor	Cools the motor related to the fusing and the paper exit sections.	OFF	ON	CN12	19	PCU	
FUM_D	Fusing drive motor [Brushless motor]	Drives the fusing unit.	Drive	Stop	CN13	17	PCU	
FUM_LD	Fusing drive motor lock detection	Detects the fusing drive motor lock.	–	Lock detection	CN13	19	PCU	
HL_LM_out	Lower heater lamp	Turns ON/OFF the lower heater lamp.	OFF	ON	CN13	13	PCU	
HL_UM_out	Heater lamp main	Turns ON/OFF the heater lamp main.	OFF	ON	CN13	9	PCU	
HL_US_out	Heater lamp sub	Turns ON/OFF the heater lamp sub.	OFF	ON	CN13	11	PCU	
HLPCD	Fusing pressure detection sensor [Transmission sensor]	Detects a change in the fusing pressure.	Pressure release	Pressure applying	CN13	3	PCU	
HUD_M	Humidity detection	Detects the humidity.	–	–	CN10	4	PCU	Analog detection
INT_CNT	Interlock control	ON/OFF control of INT24V1,V2	ON	OFF	CN11	14	PCU	
LAMP	Scanner lamp	Radiates light onto a document for the CCD to scan the document image.	ON	OFF	CN8	3	SCNcnt	
MHPS	Scanner home position sensor	Detects the scanner home position.		Home position	CN10	1	SCNcnt	
MIM_*	Scanner motor	Scanner (reading) section			CN7	1, 2, 3, 4	SCNcnt	
MPED	Manual feed paper empty detection [Transmission type]	Detects paper empty in the manual paper feed tray.	YES	NO	CN10	1	PCU	
MPFS	Paper pickup solenoid (Manual paper feed) [Electromagnetic solenoid]	Paper pickup solenoid (Manual paper feed) [Electromagnetic solenoid]	Pickup	–	CN10	3	PCU	
MPLD	Manual feed paper length detector	Detects the paper length in the manual paper feed tray.	–	Detection	CN10	10	PCU	
MPWS	Manual feed tray paper width sensor	Detects the paper width in the manual feed tray.	–	–	CN10	8	PCU	
nBD	LSU synchronization detection signal (BD signal)	Detects synchronization of the LSU in the main scanning direction.	Detection	–	CN500	62	LSU-Mother	
nOFF_CNT	+5VL power OFF signal	Turns OFF the +5VL power.	Turned ON	Turned OFF	CN14	2	LSU-Mother	Only 5VO is ON.
nPOLY_CK	Polygon motor clock signal	Controls the speed of the polygon motor.	–	–	CN500	28	LSU-Mother	
nPOLY_LOCK	Polygon motor lock signal	Detects the polygon motor lock.	–	Lock detection	CN500	29	LSU-Mother	Pulse (Duty) drive
nPOLY_START	Polygon motor ON signal	Drives the polygon motor of the LSU unit.	Drive	Stop	CN500	30	LSU-Mother	
nPOW_LED	Main power LED signal	Checks that the main power source is ON.	Green lighting	Orange lighting	CN10	6	LSU-Mother	
nPWRSW	Power switch signal	Detects ON/OFF of the power.	Detection	–	CN10	1	LSU-Mother	
nRY_CNT	Main system power OFF signal	Turns OFF the power other than +5VO and +5VL.	Turned ON	Turned OFF	CN14	1	LSU-Mother	Only 5VL_5VO is ON.
nWU_KEY	Energy saving switch signal	Shifts to the energy save mode.	Detection	–	CN10	2	LSU-Mother	
nWU_LED	Energy saving LED signal	Checks that the machine is shifted to the energy save mode.	ON	OFF	CN10	8	LSU-Mother	Pulse (Duty) drive
OSM	Shifter motor [Stepping motor]	Offsets the paper.	–	–	CN12	7, 8, 9, 10	PCU	Drives with the 4-phase signal.
PFC_HPFC	PS front clutch	Controls the PS front clutch.	ON	OFF	CN11	22	PCU	
PFM	Transport motor		–	–	CN11	30, 32, 34	PCU	
PFM_CNT	Transport motor current select	Selects the transport motor current.	Current Large	Current Small	CN11	28	PCU	
POD1	Fusing rear detection [Transmission type]	Detects the paper exit from fusing.	Pass	–	CN13	4	PCU	
POD2	Paper exit detection [Transmission type]	Detects the discharged paper.	Pass	–	CN13	10	PCU	



Signal name	Name [Type]	Function/Operation	Connector level		Connector No.	Pin No.	PWB name	NOTE
			L	H				
POD3	Right tray paper exit detection	Detects paper exit to the right tray.	Pass	–	CN10	16	PCU	
POFM_CNT	Paper exit cooling fan motor speed control	Controls the speed of the paper exit cooling fan motor.	–	–	CN12	13, 14	PCU	Pulse (Duty) drive
POFM_LD1	POFM lock detection	Detects the POFM lock.	–	Lock detection	CN12	17	PCU	
POFM_LD2	POFM lock detection	Detects the POFM lock.	–	Lock detection	CN12	18	PCU	
POFM_V	Paper exit cooling fan motor	Cools the fusing unit.	Stop	Drive	CN12	11, 12	PCU	
POM	Paper exit drive motor	Drives the paper exit roller.	–	–	CN11	5, 7, 9, 11	PCU	
POM_CNT	Paper exit drive motor current select	Selects the paper exit drive motor current.	Current Large	Current Small	CN11	13	PCU	
PPD1	Registration front detection [Transmission type]	Detects paper in front of the registration roller.	Pass	–	CN9	14	PCU	
PPD2	Registration detection	Detects paper at the rear of the registration roller.	Pass	–	CN9	16	PCU	
PRM	Fusing pressure release motor [Stepping motor]	Changes the fusing voltage.	–	–	CN12	1, 2, 3, 4	PCU	Drives with the 4-phase signal.
PROFM1_CNT	Process fan motor 2 speed control	Controls the speed of the process fan motor.	–	–	CN19	29	PCU	
PROFM1_LD	Process fan motor 2 lock detection	Process fan motor lock detection	–	Lock detection	CN19	22	PCU	
PROFM1_V	Process fan motor 2	Cools the process.	OFF	ON	CN19	33	PCU	
PROFM2_CNT	Process fan motor 2 speed control	Controls the speed of the process fan motor 2.	–	–	CN9	4	PCU	Pulse (Duty) drive
PROFM2_LD	Process fan motor 2 lock detection	Detects process fan motor 2 lock.	–	Lock detection	CN9	8	PCU	
PROFM2_V	Process fan motor 2	Cools the process.	OFF	ON	CN9	2	PCU	
PRTPD	Right paper exit tray paper empty detection	Detects paper empty in the right paper exit tray.	NO	YES	CN10	15	PCU	
PSFM_LD	Power cooling fan motor lock detection	Detects the power cooling fan motor lock.	–	Lock detection	CN19	30	PCU	
PSFM_V	Power cooling fan motor	Cools the power unit.	Stop	Drive	CN19	28	PCU	
REGS_F	Registration sensor (Front) [Reflection type]	Registration shift detection	–	–	CN17	A-2	PCU	Analog detection
REGS_F_LED	Registration sensor LED (Front) [LED]	Registration sensor LED light emitting	–	–	CN17	A-3	PCU	Analog output
REGS_R	Registration sensor (Rear) [Reflection type]	Registration shift detection	–	–	CN17	A-6	PCU	Analog detection
REGS_R_LED	Registration sensor LED (Rear) [LED]	Registration sensor LED light emitting	–	–	CN17	A-7	PCU	Analog output
RRM	Registration motor		–	–	CN11	31, 33	PCU	
RRM_CNT	Registration motor current select	Selects the registration motor current.	Current Large	Current Small	CN11	27	PCU	
SHPOS	Shifter home position sensor	Detects the shifter home position.	–	Home position	CN13	22	PCU	
TCS_C	Toner density sensor [Magnetic sensor]	Detects the toner density (C)	–	–	CN15	B-7	PCU	Analog detection
TCS_K	Toner density sensor [Magnetic sensor]	Detects the toner density (K)	–	–	CN15	B-16	PCU	Analog detection
TCS_M	Toner density sensor [Magnetic sensor]	Detects the toner density (M)	–	–	CN15	A-7	PCU	Analog detection
TCS_Y	Toner density sensor [Magnetic sensor]	Detects the toner density (Y)	–	–	CN15	A-16	PCU	Analog detection
TFD2	Paper exit full detection [Transmission type]	Detects the face-down paper exit tray full.	Full	–	CN13	16	PCU	
TFD3	Right tray paper exit full detection	Detects paper exit full in the right tray.	Full	–	CN10	13	PCU	
TH_LM_IN	Lower thermistor	Detects the temperature.	–	–	CN17	B-11	PCU	Analog detection
TH_M	Temperature detection	Detects the temperature.	–	–	CN10	6	PCU	Analog detection
TH_UM_CS_IN	Main thermistor	Detects the temperature.	–	–	CN17	B-7	PCU	Analog detection
TH_UM_IN	Main thermistor	Detects the temperature.	–	–	CN17	B-6	PCU	Analog detection
TH_US_IN	Sub thermistor	Detects the temperature.	–	–	CN17	B-9	PCU	Analog detection
TH1_LSU	LSU unit thermistor	Detects the temperature.	–	–	CN2	A-2	PCU	Analog detection
TNFD	Waste toner full detection switch [Mechanical switch]	Detects waste toner full.	Empty	Full	CN9	10	PCU	

Signal name	Name [Type]	Function/Operation	Connector level		Connector No.	Pin No.	PWB name	NOTE
			L	H				
TNM_C	Toner motor C [Stepping motor]	Transports toner from the toner cartridge to the developing unit.	–	–	CN16	17, 18, 19, 20	PCU	Drives with the 4-phase signal.
TNM_K	Toner motor K [Stepping motor]	Transports toner from the toner cartridge to the developing unit.	–	–	CN16	25, 26, 27, 28	PCU	Drives with the 4-phase signal.
TNM_M	Toner motor M [Stepping motor]	Transports toner from the toner cartridge to the developing unit.	–	–	CN19	17, 19, 25, 27	PCU	Drives with the 4-phase signal.
TNM_Y	Toner motor Y [Stepping motor]	Transports toner from the toner cartridge to the developing unit.	–	–	CN19	5, 7, 13, 15	PCU	Drives with the 4-phase signal.
WEBEND	Web end detection	Detects the fusing web end.	–	End	CN17	B-2	PCU	
WEBS	Web drive solenoid	Drives the web.	ON	OFF	CN17	B-4	PCU	

# [14] SPECIFICATIONS

## 1. 18cpm/20cpm machine

### A. Basic specifications

#### (1) Engine Specification

Photo-conductor kind	OPC (Diameter: Black: φ30mm Color (Y/M/C): φ30mm x3 lines)
Copying method	Electronic photo (Laser)
Developing system	Dry, 2-component magnetic brush development
Charging system	Charged saw-tooth method
Transfer system	Intermediate/secondary transfer belt
Separation system	Natural separation method * Sub separation claw is equipped.
Cleaning system	Counter blade
Fusing system	Heat roller method
Waste toner disposal	No toner recycling system / Waste toner bottle system
Toner supply during operation	N/A
Outer Color	Pastel white, natural wave design

#### (2) Engine speed (ppm)

##### Tray 1 - 4

Paper size	18cpm machine		20cpm machine	
	Mono-chrome	Color	Mono-chrome	Color
A3, 11" x 17", 8K	10		10	
B4, 8.5" x 14", 8.5" x 13", 8.5" x 13.4", 8.5" x 13.5"	12		12	
A4, B5, 8.5" x 11", 16K	18		20	
A4R, 16KR, 8.5" x 11"R, B5R, 7.25" x 10.5"R	14		14	
A5R, 5.5" x 8.5"R	14		14	
Extra	9		9	
Heavy paper (A3, 11" x 17", 8K)	7		7	
Heavy paper (B4, 8.5" x 14", 8.5" x 13", 8.5" x 13.4", 8.5" x 13.5")	7		7	
Heavy paper (A4, B5, 8.5" x 11", 16K)	12		12	
Heavy paper (A4R, B5R, 8.5" x 11"R, 7.25" x 10.5"R, 16KR)	9		9	
Heavy paper (A5R, 5.5" x 8.5"R)	12		12	
Heavy paper (Extra)	7		7	

#### Manual paper feed

Paper size	18cpm machine		20cpm machine	
	Mono-chrome	Color	Mono-chrome	Color
A3, 11" x 17", 8K	10	10	10	10
B4, 8.5" x 14", 8.5" x 13", 8.5" x 13.4", 8.5" x 13.5"	12	12	12	12
A4, 8.5" x 11", 16K	18	17	20	17
B5	18	18	20	20
A4R, 16KR, 8.5" x 11"R	14	14	14	14
B5R, 7.25" x 10.5"R	14	14	14	14
A5R, 5.5" x 8.5"R	14	14	14	14
A3W, 12" x 18" *2	9	9	9	9
OHP (A4, 8.5" x 11")	12	11	12	11
OHP (A4R, 8.5" x 11"R)	9	9	9	9
Extra	9	9	9	9
Envelope (Monarch, Com-10, DL, C5, Chokey-3, Chokey-4, Youkei-2, Youkei-4, Kakugata-2, Kakugata-3)	8	7	8	7
Heavy paper (A3, 11 x 17, 8K)	7	6	7	6
Heavy paper (B4, 8.5" x 14", 8.5" x 13", 8.5" x 13.4", 8.5" x 13.5")	7	6	7	6
Heavy paper (A4, 8.5" x 11", 16K, B5)	12	11	12	11
Heavy paper (A4R, 16KR, 8.5" x 11"R, B5R, 7.25" x 10.5"R)	9	9	9	9
Heavy paper (A5R, 5.5" x 8.5"R)	12	11	12	11
Heavy paper (A3W, 12 x 18 )	7	6	7	6

Paper size	18cpm machine		20cpm machine	
	Mono-chrome	Color	Mono-chrome	Color
Heavy paper (Extra)	7	6	7	6
Heavy paper (Post Card HIGH) *1	12	12	12	12
Heavy paper (Post Card LOW) *1	7	7	7	7

\*1: Switched by the service simulation setting. Postcard is set Low before shipment.

#### (3) Printable area

	297 x 420mm	12" x 18" *1	279 x 432mm
A3 Wide *1	297 x 420mm	12" x 18" *1	279 x 432mm
A3	293 x 413mm	11" x 17"	275 x 425mm
B4	253 x 357mm	8.5" x 14"	212 x 349mm
A4	206 x 290mm	8.5" x 13.5"	212 x 336mm
B5	178 x 250mm	8.5" x 13.4"	212 x 333mm
A5	144 x 203mm	8.5" x 13"	212 x 323mm
Postcard	96 x 141mm	Executive	180 x 260mm
8K	266 x 383mm	8.5" x 11"	212 x 272mm
16K	191 x 263mm	5.5" x 8.5"	136 x 209mm
Custom	Min: 96mm x 141mm Max: 297mm x 432mm		

\*1: The printable area for A3W/12" x 18" must be as large as the A3/11" x 17" page full bleed (299 x 450mm).

Void area	Lead edge: 4mm or less
Image loss	Rear edge: 2 mm or more, and 5 mm or less Total of the lead edge and the rear edge: 8mm or less FR total: 4mm±2mm or less

#### (4) Engine resolution

Resolution*1	Copy	Writing 600 x 600dpi 9,600 (equivalent) x 600dpi
	Print	Writing 600 x 600dpi 9,600 (equivalent) x 600dpi
Gradation *2 (256 levels)	Copy	Writing 600 x 600dpi x 1bit 9,600 (equivalent) x 600dpi
	Print	Writing Sharp Advanced Printing Language: 600 x 600dpi x 1bit (When HDD installed: 600 x 600dpi x 2bit), 9,600dpi (equivalent) x 600dpi PCL: 600 x 600dpi x 1bit 600 x 600dpi x 4bit 9,600 (equivalent) x 600dpi PS: 600 x 600dpi x 1bit 600 x 600dpi x 4bit 9,600 (equivalent) x 600dpi

\*1: Resolution: 600dpi (default)

\*2: The Dither and Error Diffusion methods using 8 bit input will be performed.

#### (5) Scanner section

##### a. Resolution/Gradation

Scanning Resolution (dpi)		Monochrome	Color
	Platen	600 x 600dpi 600 x 400dpi 600 x 300dpi (default)	600 x 600dpi
RSPF	600 x 600dpi 600 x 400dpi (default)	600 x 600dpi	
Exposure lamp	White LED		
Reading gradation	10bit		
Output gradation	BW: 1bit Grayscale: 8bit Full Color: each color RGB 8bit		

**b. Document table**

Type	Document table fixed system (Flat bed)
Scanning area	297 x 432mm
Original standard position	Left rear reference
Detection	Yes
Detection size	Automatic detection (One type of detection unit to be switched for software destination)
Dehumidifying heater (Scanner section)	Supplied as a service parts

**(6) Document feeder (Option)**

Type	RSPF (Reversing single pass feeder)	
Scan speed	Monochrome (A4/8.5" x 11")	Color (A4/8.5" x 11")
Copy	Single: 50-sheet/min. (600 x 400dpi, 4bit) 36-sheet/min. (600 x 600dpi, 4bit) Double: 20-page/min. (600 x 400dpi, 4bit) 17-page/min. (600 x 600dpi, 4bit)	Single: 36-sheet/min. (600 x 600dpi, 4bit) Double: 17-page/min. (600 x 600dpi, 4bit)
FAX	Single: 50-sheet/min. (200 x 200dpi, 1bit) Double: 20-page/min. (200 x 200dpi, 1bit)	NA
Internet FAX	Single: 50-sheet/min. (200 x 200dpi, 1bit) Double: 20-page/min. (200 x 200dpi, 1bit)	NA
Scanner	Single: 50-sheet/min. (200 x 200dpi, 1bit) Double: 20-page/min. (200 x 200dpi, 1bit)	Single: 50-sheet/min. (200 x 200dpi, 8bit) Double: 20-page/min. (200 x 200dpi, 8bit)
Original setup direction	Upward standard (1 to N feeding standard)	
Original standard position	Center standard (Rear one-side standard for random feeding)	
Original transport method	Sheet-through method	
Original size	<p>Standard size</p> <p>Inch-1: 11" x 17", 8.5" x 14", 8.5" x 11", 8.5" x 11"R, 5.5" x 8.5", A3, A4</p> <p>Inch-2: 11" x 17", 8.5" x 13", 8.5" x 11", 8.5" x 11"R, 5.5" x 8.5", A3, A4</p> <p>Inch-3: 11" x 17", 8.5" x 13.4", 8.5" x 11", 8.5" x 11"R, 5.5" x 8.5", A3, A4</p> <p>AB-1: 11" x 17", 8.5" x 14", 8.5" x 11", A3, B4, A4, A4R, B5, B5R, A5</p> <p>AB-2: 11" x 17", 8.5" x 13", 8.5" x 11", A3, B4, A4, A4R, B5, B5R, A5</p> <p>AB-3: 11" x 17", 8.5" x 13", 8.5" x 11", A3, B4, A4, A4R, A5, 8K, 16K, 16KR</p> <p>AB-4: 11" x 17", 8.5" x 13.4", 8.5" x 11", A3, B4, A4, A4R, B5, B5R, A5</p> <p>AB-5: 11" x 17", 8.5" x 13.5", 8.5" x 11", A3, B4, A4, A4R, B5, B5R, A5</p>	
	Long paper	1000 mm (Monochrome binary only) Internet Fax 600 x 600 dpi: Max. 800 mm. When scan 400 dpi or more, long paper is not available.
Mix paper feed (Same series, same width paper)	Enabled	
Random feeding (feeding of different types / different widths)	<p>Enabled</p> <p>Only the following combinations of 2 size types are allowed: A3 and B4; B4 and A4R; A4 and B5; B5 and A5; and 11-inch and 8.5-inch. AMS available. 2-sided scanning is disabled during random feeding.</p>	

Original copy weight	<p>Single: Thin paper: 9 - 13 lb bond (35 - 49 g/m<sup>2</sup>) Plain paper: 13 - 32 lb bond (50 - 128 g/m<sup>2</sup>) * Thin paper mode (39 pages/minute (A4, 8.5" x 11", 600 x 400dpi) / 26 pages/minute (A4, 8.5" x 11", 600 x 600dpi) is set up for the thin paper. Duplex: 13 - 28 lb bond (50 - 105 g/m<sup>2</sup>)</p>
Max. loading capacity of documents	Max. 100 sheets (21lbs Bond, 80g/m <sup>2</sup> ), or Max. height: 1/2 inch, 13mm or less
Un-acceptable originals for feeding.	OHP, second original paper, tracing paper, carbon paper, thermal paper, paper with wrinkles, folds, or breakage, pasted paper, cutout document, document printed with ink ribbon, documents with perforation other than 2- or 3-holes (Perforated document by punch unit is allowed.)
Detection	Yes
Paper detection size	Auto detection
Paper feeding direction	Right hand feeding
Finish stamp	Option

**(7) Paper feed section**

**a. Basic specifications**

Type	Standard	1-stage paper feed tray + multi manual paper feed tray
	Full option	4-stage paper feed tray + multi manual paper feed tray
Dehumidifying heater	Service parts (Supported by kit)	

Tray	Tray 1	Manual paper feed tray
Paper capacity Plain paper (80g/m <sup>2</sup> )	500 sheets	100 sheets
Paper size	Refer to the separate table of feedable paper type.	
Paper size detection	No (Guide adjustment and size input)	Yes
Paper type settings	Yes	
Changing of paper size	Switched by users	
Universal handle	Yes (With the handle lock mechanism)	-
Default Paper Size Setting	A4 (8.5" x 11")	-
Paper remaining quantity detection	Paper empty and 3 steps (100%, 67%, 33%, and paper empty)	Only detection of paper empty
Paper size display window	Yes	-

**b. Extra paper capacity**

Paper type	Paper feed tray	Manual feed tray
Postcard	NA	20 sheets
Envelope	NA	20 sheets
OHP	NA	20 sheets
Heavy paper	200 sheets	40 sheets
Tab paper	NA	20 sheets
Glossy paper	NA	1 sheet
Others	NA	1 sheet

**c. Size of paper which can be fed**

Paper feed section			Main unit tray	Optional Drawer				Manual paper feed tray
			Tray 1	Tray 2	Tray 3	Tray 4		
Paper size	12" x 18" (A3W)		-	-	-	-	Yes	
	11" x 17"		Yes	Yes	Yes	Yes	Yes	
	8.5" x 14" (216 x 356)		Yes	Yes	Yes	Yes	Yes	
	8.5" x 13.5" (216 x 343)		Yes	Yes	Yes	Yes	Yes	
	8.5" x 13.4" (216 x 340)		Yes	Yes	Yes	Yes	Yes	
	8.5" x 13" (216 x 330)		Yes	Yes	Yes	Yes	Yes	
	8.5" x 11"		Yes	Yes	Yes	Yes	Yes	
	8.5" x 11"R		Yes	Yes	Yes	Yes	Yes	
	7.25" x 10.5"R		Yes	Yes	Yes	Yes	Yes	
	5.5" x 8.5"R		Yes	Yes	Yes	Yes	Yes	
	A3		Yes	Yes	Yes	Yes	Yes	
	B4		Yes	Yes	Yes	Yes	Yes	
	A4		Yes	Yes	Yes	Yes	Yes	
	A4R		Yes	Yes	Yes	Yes	Yes	
	B5		Yes	Yes	Yes	Yes	Yes	
	B5R		Yes	Yes	Yes	Yes	Yes	
	A5R		Yes	Yes	Yes	Yes	Yes	
	8K		Yes	Yes	Yes	Yes	Yes	
	16K		Yes	Yes	Yes	Yes	Yes	
	16KR		Yes	Yes	Yes	Yes	Yes	
Envelope		-	-	-	-	Yes		
Custom		Yes	Yes	-	-	Yes		
Paper type	Thin paper	13-16lb bond (55-59g/m <sup>2</sup> )	No	No	No	No	Yes	
	Plain paper	16-28lb bond (60-105g/m <sup>2</sup> )	Yes	Yes	Yes	Yes	Yes	
		Recycled paper	Yes	Yes	Yes	Yes	Yes	
		Color paper	Yes	Yes	Yes	Yes	Yes	
		Letter head	Yes	Yes	Yes	Yes	Yes	
		Pre printed	Yes	Yes	Yes	Yes	Yes	
		Pre Punched	Yes	Yes	Yes	Yes	Yes	
	Heavy paper	28lb bond - 110lb index (106-209g/m <sup>2</sup> )	Yes	Yes	Yes	Yes	Yes	
		110lb index-140lb index (210-256g/m <sup>2</sup> )	-	-	-	-	Yes	
	Envelope	75-90g/m <sup>2</sup>	-	-	-	-	Yes	
	OHP Transparency		-	-	-	-	Yes	
	Label		-	-	-	-	Yes	
	Tab paper		-	-	-	-	Yes	
	Glossy paper		-	-	-	-	Yes	
	User settings 1 - 7		Yes	Yes	Yes	Yes	Yes	

**(8) Paper exit section**

**a. Exit Capacity**

Exit location	Center	Right side (option)
Exit Capacity	400 sheets (A4/8.5" x 11": 80g/m <sup>3</sup> )	100 sheets (A4/8.5" x 11": 80g/m <sup>3</sup> )

**b. Size of paper which can be discharged**

Paper exit section			Duplex	Main unit center tray		Right exit tray
				Exit tray	Off set	
Paper size	12" x 18" (A3W)		-	-	-	Yes
	11" x 17"		Yes	Yes	Yes	Yes
	8.5" x 14" (216 x 356)		Yes	Yes	Yes	Yes
	8.5" x 13.5" (216 x 343)		Yes	Yes	Yes	Yes
	8.5" x 13.4" (216 x 340)		Yes	Yes	Yes	Yes
	8.5" x 13" (216 x 330)		Yes	Yes	Yes	Yes
	8.5" x 11"		Yes	Yes	Yes	Yes
	8.5" x 11"R		Yes	Yes	Yes	Yes
	7.25" x 10.5"R		-	Yes	Yes	Yes
	5.5" x 8.5"R		Yes	Yes	Yes	Yes
	A3		Yes	Yes	Yes	Yes
	B4		Yes	Yes	Yes	Yes
	A4		Yes	Yes	Yes	Yes
	A4R		Yes	Yes	Yes	Yes
	B5		Yes	Yes	Yes	Yes
	B5R		Yes	Yes	Yes	Yes
	A5R		Yes	Yes	Yes	Yes
	8K		Yes	Yes	Yes	Yes
	16K		Yes	Yes	Yes	Yes
	16KR		Yes	Yes	Yes	Yes
Envelope		-	Yes	-	-	
Custom		Yes	Yes	-	Yes	
Paper type	Thin paper	13-16lb bond (55-59g/m <sup>2</sup> )	-	Yes	Yes	Yes
	Plain paper	16-28lb bond (60-105g/m <sup>2</sup> )	Yes	Yes	Yes	Yes
		Recycled paper	Yes	Yes	Yes	Yes
		Color paper	Yes	Yes	Yes	Yes
		Letter head	Yes	Yes	Yes	Yes
		Pre printed	Yes	Yes	Yes	Yes
		Pre Punched	Yes	Yes	Yes	Yes
	Heavy paper	28lb bond - 110lb index (106-209g/m <sup>2</sup> )	Yes	Yes	Yes	Yes
		110lb index - 140lb index (210-256g/m <sup>2</sup> )	-	Yes	Yes	Yes
	Envelope	75-90g/m <sup>2</sup>	-	Yes	-	-
	OHP Transparency		-	Yes	-	Yes
	Label		-	Yes	-	Yes
	Tab paper		-	Yes	-	-
	Grossy paper		-	Yes	Yes	-
User settings 1 - 7		Yes	Yes	Yes	Yes	

**(9) Operation panel**

Size	7 inch
Type	Dot matrix LCD, touch panel
Display dot number	800 x 480 dots (WVGA)
LCD back-light	LED lamp back-light system

**(10) Controller board**

Machine	18cpm	20cpm
CPU	ARM11: 600MHz ARM9: 400MHz/during 1W energy save mode: 75MHz	
PCL accelerator (OPT)	MPC8535 Power QUICC e500 800MHz	
Interface		
Ethernet	1port	
Interface	10Base-T, 100Base-TX	10Base-T, 100Base-TX, 1000Base-T
Support Protocol	TCP/IP (IPv4, IPv6), IPX/SPX, NetBEUI, EtherTalk	
USB 2.0 (high speed) (host)	1port	2port (Simultaneous use of the front/rear ports is enable.)
USB 2.0 (high speed) (device)	1port	
USB-HUB (host)	Internal: 3port • For Rear USB Port • Reserved • Reserved	Internal: 4port • For Front USB Port • For Rear USB Port • Reserved • Reserved
Serial I/F	1port	
Memory	See the section "Memory/Hard disk".	
Memory slot	Main unit: 2 slot (1 slot: empty)* PCL (OPT): 2 slot (1 slot: empty) *: 18cpm onboard, without 1GB expansion slot	

## (11) Memory/Hard disk

Machine	SD card	MFP control PWB	Printer control PWB*1		HDD*2
		SLOT1	SLOT3	SLOT4	
18cpm	4GB	1GB (STD)	512MB (STD)	1GB (OPT)	160GB (OPT)
20cpm	8GB	*18cpm (onboard)			

\*1: Memory capacity of Printer Expansion Kit (OPT) controller

\*2: HDD capacity depends on procurement and sourcing status.

Memory area (SD card)	Boot/Program area
	FAX data storage area With HDD: 1GB Without HDD: 512MB

## (12) Warm-up time

	Main power SW
Warm-up time*1	45sec. or less
Pre heat	Yes
Jam recovery time*2	37sec. or less

\*1: Result may change depending on conditions.

\*2: Conditions: Leave the machine for 60 sec. after door open, standard condition, Polygon stops.

## B. Copy functions

### (1) First copy time

Engine	Monochrome	Color
Platen	8.8 sec.	10.2 sec.
RSPF	11.5 sec.	16.3 sec.

### (2) Job Speed

Engine	18cpm		20cpm	
	Monochrome	Color	Monochrome	Color
S to S	18cpm (100%)	18cpm (100%)	20cpm (100%)	20cpm (100%)

### (3) Job Effectiveness

BLI Standard (RSPF)

Engine	Monochrome	Color
S to S	18cpm (90%)	17cpm (85%)
S to D	15cpm (75%)	14cpm (70%)
D to D	16cpm (80%)	16cpm (80%)

\* S to S: 10 pages of A4 / 8.5" x 11" document and 5 copies

\* S to D: 10 pages of A4 / 8.5" x 11" document and 5 copies

\* D to D: 10 pages (20 sides) of A4 / 8.5" x 11" document and 5 copies

## C. Printer function

### (1) Printer driver supported OS

OS	Custom PCL6	Custom PS	PPD	Sharp Advanced Printing Language	PC-FAX
Windows	2000	CD-ROM	CD-ROM	CD-ROM	CD-ROM
	XP	CD-ROM	CD-ROM	CD-ROM	CD-ROM
	XP (x 64)	CD-ROM	CD-ROM	CD-ROM	CD-ROM
	Server 2003	CD-ROM	CD-ROM	CD-ROM	CD-ROM
	Server 2003 (x 64)	CD-ROM	CD-ROM	CD-ROM	CD-ROM
	Vista	CD-ROM	CD-ROM	CD-ROM	CD-ROM
	Vista (x 64)	CD-ROM	CD-ROM	CD-ROM	CD-ROM
	Server 2008	CD-ROM	CD-ROM	CD-ROM	CD-ROM
	Server 2008 (x 64)	CD-ROM	CD-ROM	CD-ROM	CD-ROM
	Windows 7	CD-ROM	CD-ROM	CD-ROM	CD-ROM
Windows 7 (x 64)	CD-ROM	CD-ROM	CD-ROM	CD-ROM	
Mac	9.0-9.2.2	No	No	Web	No
	X 10.2.8	No	No	Web	No
	X 10.3.9	No	No	Web	No
	X 10.4.11	No	No	CD-ROM	No
	X 10.5-10.5.8	No	No	CD-ROM	No
	X 10.6-10.6.5	No	No	CD-ROM	No

### (2) PDL emulation/Font

PDL (Command)		Installed font	Option font
PCL6 compatibility	OPT	European outline font = 80 styles Line printer font (BMP) = 1 style	Barcode font = 28 styles
Postscript3 compatibility	OPT	-	European outline font = 136 styles

## D. FAX function

### (1) Transmission method

Transmission time	Less than 3 sec (Super G3) Less than 7 sec (G3 ECM)
Compression/ expansion system	MH, MR, MMR, JBIG (Fixed to ECM for MMR or JBIG.)
Modem speed	33.6kbps → 2.4kbps automatic fallback
Resolution	8 x 3.85 line/mm, 8 x 7.7 line/mm, 8.15.4 line/mm, 16 x 15.4 line/mm (Standard memory is used for transmit/receive.)
Intercommunication	G3/Super G3: Standard (V.34, V.17, V.33, V.29, V.27ter)
Communication line	General telephone line (PSTN), ISDN (When TA is installed.) Private Branch Exchange (PBX)
ECM	Yes

### (2) Number of Support Line

Standard	1 line
Expansion	Not provided

### (3) Transmission Mode

RSPF/OC transmission switching	Yes (Switching during the reading is not feasible)
-----------------------------------	--

### (4) Image Quality/Image Process

Half tone reproduction	Equivalent to 256 levels (Valid only when monochrome document is scanned.)
Exposure adjustment	Auto / Manual (5 steps)
FAX quality selection	Standard (8 x 3.85 lines/mm (203.2 x 97.8dpi)) Fine (8 x 7.7 lines/mm (203.2 x 195.6dpi)) Super Fine (8 x 15.4 lines/mm (203.2 x 391dpi)) Ultra Fine (16 x 15.4 lines/mm (406.4 x 391dpi)) Half-tone (Combination with normal character is invalid.)

### (5) Record Size

Max. record width	293mm
Record size	(AB series) A3, B4, A4, A4R, B5, B5R, A5R (Inch series) 11 x 17, 8.5 x 13, 8.5 x 14, 8.5 x 11, 8.5 x 11R, 8.5 x 5.5R

\* If the document length exceeds A3 size, it is divided and printed.

\* For printing the list, A5R and 8.5 x 5.5R cannot be used.

### (6) Dial

Manual dialing	To be entered by 10-key, # key, * key
Re-dialing	The previous 8 items (max.) can be saved, and one of them can be selected. One-touch call is available.
One-touch dialing	1000 items including the group dialing items
Group dialing	1000 items including the one-touch dialing items
Program dialing	Max. 48 items
Chain dialing	Max. 64 digits including one-touch dialing, 10-key dialing, and pause.
Dial search	Alphabet order search, User index groups
Quick search	Yes
LDAP search	Yes
Sub address	Yes
Password	Yes
Memory box registration	Yes

\* LDAP: Lightweight Directory Access protocol

### (7) Memory for Transmit/Receive

FAX transmission data	HDD
FAX reception data	SD card

## (8) Function

Transmit function	Calling function	Yes Requires the frequency setting for each destination.
	PBX function	Germany, France only
	Memory transmit	Yes (Definable destinations : 94 destinations)
	On-hook	Yes
	Quick online transmit	Yes
	Direct transmit	Yes
	Manual transmit	Yes
	Auto re-call mode	Yes
	Time indication function	Yes
	Sequential broadcasting function	Yes
	F code interface broadcasting indication function	Yes Only one interface station can be specified.
	F code interface broadcasting function	Yes
	F code confidential send function	Yes
	Polling	Yes Even with another company machine
	Sequential polling function	Yes Even with another company machine
	F-code polling	Yes
	Bulletin board	Yes
	F code bulletin board function	Yes
	Auto reduction transmit	Yes A3 → B4, A3 → A4, B4 → A4
	Rotation transmit	Yes Counterclockwise rotation of 90 degrees
	Duplex transmit	Yes
	Document transmit from OC function	Yes
	Long length original transmit	Only when RSPF is used. Transmission is enable up to 1000mm.
Mixed documents function	Only when RSPF is used.	
Zoom transmit	Yes	
2 in 1 transmit	Yes	
Card shot transmit	Only when transmitting from OC	
Thin paper scan function	Available except for duplex scan	
Edge erase transmit function	Yes Only for the fixed sizes	
Job build	Yes	
Page division transmit	Yes	
Cover	No	
Index	No	
Transmit message adding function	No	
Receive function	Auto receive	Yes
	Manual receive	Yes
	DRD call function	Distinctive Ring Detection North America: Standard, Pattern 1 – 5 Australia/New Zealand/Hong Kong: ON/OFF (TEL/FAX)
	Memory receive	Yes
	Transfer function	Yes Number of registration: 1 item
	Specified receive function	Yes (Number of registration) Rejection numbers: Max.50 items
	Receive data print condition function	Yes



Receive function	Receive data staple setting/ Copy number setting	Yes
	Rotation receive	Yes Output by clockwise rotation of 90 degrees
	Divided receive	Yes Divided print is not made in duplex mode.
	Duplex receive	Yes
	F-code confidential receive	Yes
Special function	Print hold	Yes
	Document Admin	Yes
	Inbound Routing	Yes
	Sender registration function	Yes
	Sender print function	Yes
	On-hook dialing function	Yes
	Retransmit function	Yes
	Pause function	Yes Pause time is 1 – 15 sec.
	Sound volume setting function	Yes
	Tone pulse select function	Tone, Pulse, Auto (North America/Taiwan) * For the other destinations, set with the soft switch.
	External phone connection	Yes
	Memory remaining capacity check function	Yes Only the integral part is displayed.
	Back up	Yes
	Registered data read/write function	Yes
	Report/List	Yes
	Destination check function	Yes
	Broadcasting destination display function	Yes
	Transmit job change function	Yes
	Save-energy function	Yes
	Line monitor display function	Yes
	FAST	Yes Facsimile Automated Service Technology
	Time adjust function	Yes Summer time ON/OFF
	PC-FAX	Yes
	Color mode	No
	Sender registration function	Yes Number of registration: 1 for standard sender name and address. And 18 sender names can be registered.
	Default destination setting	No
	Unauthorized scan prevention function	Yes
Filing-each-page function	No	
Re-operation function	Yes	
User account function	Yes Max. 200 items additionally to the default	
Counter function	Yes	

## E. Image send function

### (1) Mode

FAX	FAX to e-mail/FTP
-----	-------------------

### (2) System environment

<b>Copier memory (Local memory)</b>	<b>Printer memory (System Memory)</b>
1GB (Standard)	512MB (Standard)

## (3) Image send function (Push send from the main unit)

### a. Support image

Mode	FAX
Compression method	MH, MR, MMR, JBIG

### b. Image processing

Mode	FAX
Original scanning color	B/W
Halftone reproduction	Equivalent of 256 steps
Density adjustment	Auto + 5 steps
Selection of image quality	Half tone (Black-white only) ON/OFF
Resolution (depends on file format/transmission method)	Standard character (203.2 x 97.8dpi) (half tone not allowed)
	Fine (203.2 x 195.6dpi)
	Super fine (203.2 x 391dpi)
	Ultra fine (406.4 x 391dpi)

### c. Specification of Addresses

Mode	FAX
Address specification	Specification by one-touch/group/direct address entry. Entry from 10-key. (Fax) Selection from LDAP server
Number of One-touch address key registration	Total (number of key): Maximum 1000
Number of Group (1 key) address registration	Number of Group (1 key) address registration : maximum 500 Number of Group key registration : 5000 (Total address number included in /1000 key)
Program	48
Direct entry of addresses	Entry by 10-key, # key
Chain dial	Yes (pause key)
Resend	Call up nearest 8 addresses. *1
Destination confirmation	Yes
Shortcut for address selection (quick key)	Use the 10-key to call up registered numbers of addresses.
Disable direct entry transmission *2	Yes
Disable PC- Fax sending	Yes

\*1: Except for FTP, Desktop, SMB, USB memory, Broadcast.

\*2: When disabled, the address registration is not allowed either.

### d. Specification of Multiple Addresses

Mode	FAX
Broadcast	Yes (500 destinations)
Request of serial transmission	Yes

\* Broadcast transmission is allowed. (Monochrome only)

### e. Transmission function

Mode	FAX
Memory transmission	94 destinations in all
On-hook	Yes
Quick online transmission	Yes
Direct transmission	Yes (Switching: Memory transmission ↔ Direct transmission)
Automatically-reduced transmission	Yes
Rotated transmission	Yes
Scaled transmission	Yes Enlargement/reduction is allowed only from a fixed size to another. Reduction may be done on the receiver side with Fax/Internet Fax sending.

Mode		FAX
Recall mode	Error	Yes
	Busy	Yes
		Number/time to be set up through system setup
Long original transmission	Yes	Maximum of 1000mm (single side only/black-white 2 values only)
Confidential transmission (Sharp mode)	No	
Relay broadcast transmission (Sharp mode)	No	
Large capacity original mode	Yes	
Scanning of thin paper	Yes	
Mixed originals feeder	Yes (Random + MIX)	
Default date sender transmission	Yes (ON only)	
Preview	No	
Side erase	Yes	

#### f. Reception function

Mode	FAX
Automatic reception	Yes
Manual reception	No Switching from manual reception to automatic reception. (Allowed only for France)
Memory reception	Yes
Fixed size reduced reception	Yes
Specified size scaled reception	No
Rotated reception	Yes
Setting of received data print condition	Equal size print (partition not allowed) Equal size print (partition allowed) Equal or reduced size print
2-sided reception	Condition setting through system setting
2-in-1 reception	No
Automatic reduction setting upon receiving A3	Yes
Automatic reduction setting upon receiving letter	Yes (Other than North America and Inch destinations)
Reception from a specific number not allowed, or allowed. (Allow/Reject)	Specified numbers only (50 numbers /20 digits)
External phone connection remote	Yes
Confidential reception (Sharp mode)	No
Received data bypass output	Yes
Index printing	No
Transfer function upon disabling of output.	Yes (1 receiver (of transfer) registration)
Internet Fax/Fax to e-mail (Transfer of Internet Fax/Fax reception data to e-mail, inbound routing)	Yes
Exit tray setting	Yes
Insertion of job separator sheet	No
Staple function of received data	Yes
Auto wake up print	Yes
Received data print hold *1	Yes
Color toner print when black toner runs out.	No

\*1: This function saves all received data in memory and starts output after password entry. (Confidential reception is excluded.)  
Setting only on the receiver side.

#### g. Report/list function

Mode	FAX
Image sending activity report	Yes Time-specified output Output with memory full * Maximum of 200 times including both transmission and reception
Transaction report	Yes
Address/phone number table	Yes
Group table	Yes
Program table	Yes
Memory box table (F code)	Yes
Communication original contents print	Always print/Upon error/no print
List of allowed or rejected reception numbers	Yes
Table of control record for each account	No

#### h. Other Functions

Mode	FAX
Time specification	Yes
Polling reception	Yes
Bulletin board transmission	Yes Up to 100 registrations allowed with bulletin board, confidential and relay broadcast all combined. (Free area : 1 registration) Setting of the number of transmission: 1/no limit.
Cover sheet function	No
Transmission message	No
Sender print	Yes
Sender selection	Yes
Page number print	Yes
Date print	Yes (Date can be expressed alternatively)
Polling protection function	Yes
Page partition transmission	Yes
Page connection	No
Confidential (receiver unit)	Yes (F code method)
Relay broadcast instructions	Yes (F code method)
Fax to e-mail (F code) *1	Yes
Edge erase	Yes
Center erase	Yes
2 in 1	Yes
Card shot	Yes (Equivalent or enlargement up to the paper width. The maximum enlargement is not allowed to exceed 400%)
Forward data transmission/reception (Document Admin)	Yes Data transmission by PC-Fax/ PC-Internet Fax is allowed, too.

\*1: This function means that e-mail address setting on F code relay broadcast allowed.

#### i. Transmission Method

Mode	FAX
Transmission time	2 seconds level (super G3/JBIG), 6 seconds level (G3 ECM)
Modem speed	Automatic fall-back : 33.6kbps → 2.4kbps
Intercommunication	Super G3/G3
Communication line	General membership telephone line (PSTN), independent business line (PBX), F net. (R-key for PBX setting: Germany/France)
ECM	Yes

## j. Record Size

Mode	FAX
Maximum record width	293mm
Record size	A3 – A5/11 x 17 – 5.5 x 8.5

## k. F code communication

Mode	FAX
Sub-address	Yes (20 digits)
Password	Yes (20 digits)

## l. Registration-related settings

Mode	FAX
One-touch/group *1 E-mail FTP Desktop SMB FAX	1000 destinations Use of LDAP allowed Up to 500 registered addresses for each group dial. Registered name in 18 full-size character (36 half-size characters) One-touch dial receiver number registration: within 64 digits for receiver number + sub-address + passcode (including "/").
Program	Registration of addresses (groups), settings (density, image quality) and special functions in one set is allowed. (48 of them)
Number of memory boxes	Registration of bulletin board/confidential/relay broadcast is allowed up to 100. Registration name: 18 characters
Number of sender registration	1 (default) with 20 characters
Number of sender selection registration	Total: 18 registrations (20 characters) (Sender selection: In addition to default, 18 registrations allowed)
Registration of polling approval number	10 numbers/20 digits
Registration of Fax system number (Sharp mode)	No
Registration of Fax polling approval ID number (Sharp mode)	No
Fax relay ID registration (Sharp mode)	No
Quick key (short cut registration) *2	Yes (001 – 1000)
Import/export of address book	Yes (By storage backup)
Black list (for France)	No

\*1: Since scan/Internet Fax/Fax uses the common address book, the number of addresses allowed for registration is the sum total of all modes.

\*2: Quick key is the function to select an address based on the registered number of each address within the book for address selection. Users should be able to select a quick key number.

## m. Telephone functions

Mode	FAX
On-hook function	Yes
Hold	No
Setting of pause time	Yes (1 – 15 seconds)
Telephone transmission during power outage	No (External telephone transmission allowed)
Tone pulse switching	Tone, Pulse, Auto (North America/Taiwan) * For the other destinations, set with the soft switch.

## n. Sound settings

Mode	Item	FAX
On-hook sound	Sound volume setting	1 - 9
Sound volume for calling	Sound volume setting	1 - 9, No
Line monitor sound	Sound volume setting	1 - 9, No
Reception sound	Sound volume setting	1 - 9, No
Transmission success sound	Sound volume setting	1 - 9, No
Transmission and reception error sound	Sound volume setting	1 - 9, No
Sound setting for end of original reading (image send)	Sound volume setting	Large/middle/small/no sound

## o. Others

Mode	FAX
PC-FAX	Yes
FAST	Yes (SEC only)
Network FAST	No
Distinctive ring detection	Setting for each destination

## F. Power consumption

The full configuration can be operated with the rated power source.

Maximum rated power Consumption*1	100 V	200 V
	1.44 kW	1.84 kW
Energy consumption rate	Not applicable	
TEC value (Measured result)	–	2.37kWh
TEC value (Standard) Tier2	5.50 kWh (0.1 kwh*20 + 3.5 kwh)	
Network/Fax waiting power consumption	1 W Condition: • No USB port • The network protocol is TCP/IP only. • The Ethernet connection partner supports 10M/100MBASE or 10M/100M/1000MBASE and auto negotiation setting. * Exclude the case of use Fax and Network at once)	–
Moving time to pre-heat mode	1 minutes (default)	
Recovery time from pre-heat mode	10 sec.	
Moving time to sleep mode	1 minutes (default) * Printer mode: 10sec. (default)	11 minutes (Europe) * Printer mode: 10sec. (default)
Recovery time from sleep mode	45 sec.	

\*1: Power switch ON, dehumidity heater OFF

## G. Dimensions and Weight

Outer dimension (Included operation panel)	W583 x D623 x H717mm
Footprint	W583 x 623mm (Included right exit tray) W831 x 623mm (Excluded right exit tray)
Dimension occupied by the machine (When the bypass tray is extended)	W904 x D623mm (When the right paper exit tray is extended.)
Weight Main Unit (including photoreceptor / not including consumables)	With RSPF installed: 71.8kg With OC installed: 65.0kg

## H. Ambient conditions

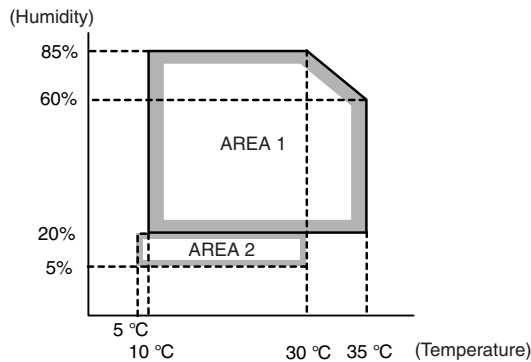

## 2. 23cpm/31cpm(G) machine

### A. Basic specifications

#### (1) Engine Specification

Photo-conductor kind	OPC (Diameter: Black: $\phi$ 30mm Color (Y/M/C): $\phi$ 30mm x3 lines)
Copying method	Electronic photo (Laser)
Developing system	Dry, 2-component magnetic brush development
Charging system	Charged saw-tooth method
Transfer system	Intermediate/secondary transfer belt
Separation system	Natural separation method * Sub separation claw is equipped.
Cleaning system	Counter blade
Fusing system	Belt method
Waste toner disposal	No toner recycling system / Waste toner bottle system
Toner supply during operation	N/A
Outer Color	Pastel white, natural wave design

#### (2) Engine speed (ppm)

##### Tray 1 - 4

Paper size	23cpm machine		31cpm(G) machine	
	Mono-chrome	Color	Mono-chrome	Color
A3, 11" x 17", 8K	11	11	15	15
B4, 8.5" x 14", 8.5" x 13", 8.5" x 13.4", 8.5" x 13.5"	13	13	17	17
A4, B5, 8.5" x 11", 16K	23	23	31	31
A4R, 16KR, 8.5" x 11"R, B5R, 7.25" x 10.5"R	15	15	20	20
A5R, 5.5" x 8.5"R	15	15	20	20
Extra	10	10	14	14
Heavy paper (A3, 11" x 17", 8K)	7	7	7	7
Heavy paper (B4, 8.5" x 14", 8.5" x 13", 8.5" x 13.4", 8.5" x 13.5")	7	7	7	7
Heavy paper (A4, B5, 8.5" x 11", 16K)	12	12	12	12
Heavy paper (A4R, B5R, 8.5" x 11"R, 7.25" x 10.5"R, 16KR)	9	9	9	9
Heavy paper (A5R, 5.5" x 8.5"R)	12	12	12	12
Heavy paper (Extra)	7	7	7	7

## Manual paper feed

Paper size	23cpm machine		31cpm(G) machine	
	Mono-chrome	Color	Mono-chrome	Color
A3, 11" x 17", 8K	11	10	15	14
B4, 8.5" x 14", 8.5" x 13", 8.5" x 13.4", 8.5" x 13.5"	13	12	17	16
A4, 8.5" x 11", 16K	20	17	26	23
B5	20	20	26	26
A4R, 16KR, 8.5" x 11"R	15	14	20	19
B5R, 7.25" x 10.5"R	15	15	20	20
A5R, 5.5" x 8.5"R	15	15	20	20
A3W, 12" x 18" *2	10	10	14	13
OHP (A4, 8.5" x 11")	12	11	12	11
OHP (A4R, 8.5" x 11"R)	9	9	9	9
Extra	10	10	14	13
Envelope (Monarch, Com-10, DL, C5, Chokey-3, Chokey-4, Youkei-2, Youkei-4, Kakugata-2, Kakugata-3)	8	7	8	7
Heavy paper (A3, 11 x 17, 8K)	7	6	7	6
Heavy paper (B4, 8.5" x 14", 8.5" x 13", 8.5" x 13.4", 8.5" x 13.5")	7	6	7	6
Heavy paper (A4, 8.5" x 11", 16K, B5)	12	11	12	11
Heavy paper (A4R, 16KR, 8.5" x 11"R, B5R, 7.25" x 10.5"R)	9	9	9	9
Heavy paper (A5R, 5.5" x 8.5"R)	12	11	12	11
Heavy paper (A3W, 12" x 18")	7	6	7	6
Heavy paper (Extra)	7	6	7	6
Heavy paper (Post Card HIGH) *1	12	12	12	12
Heavy paper (Post Card LOW) *1	7	7	7	7

\*1: Switched by the service simulation setting. Postcard is set Low before shipment.

#### (3) Printable area

A3 Wide *1	297 x 420mm	12" x 18" *1	279 x 432mm
A3	293 x 413mm	11" x 17"	275 x 425mm
B4	253 x 357mm	8.5" x 14"	212 x 349mm
A4	206 x 290mm	8.5" x 13.5"	212 x 336mm
B5	178 x 250mm	8.5" x 13.4"	212 x 333mm
A5	144 x 203mm	8.5" x 13"	212 x 323mm
Postcard	96 x 141mm	Executive	180 x 260mm
8K	266 x 383mm	8.5" x 11"	212 x 272mm
16K	191 x 263mm	5.5" x 8.5"	136 x 209mm
Custom	Min: 96mm x 141mm Max: 297mm x 432mm		

\*1: The printable area for A3W/12" x 18" must be as large as the A3/11" x 17" page full bleed (299 x 450mm).

Void area	Lead edge: 4mm or less
Image loss	Rear edge: 2 mm or more, and 5 mm or less
	Total of the lead edge and the rear edge: 8mm or less
	FR total: 4mm $\pm$ 2mm or less

#### (4) Engine resolution

Resolution*1	Copy	Writing 600 x 600dpi 9,600 (equivalent) x 600dpi
	Print	Writing 600 x 600dpi 9,600 (equivalent) x 600dpi
Gradation *2 (256 levels)	Copy	Writing 600 x 600dpi x 4bit 9,600 (equivalent) x 600dpi
	Print	Writing Sharp Advanced Printing Language: 600 x 600dpi x 1bit 600 x 600dpi x 2bit 9,600 (equivalent) x 600dpi PCL: 600 x 600dpi x 1bit 600 x 600dpi x 4bit 9,600 (equivalent) x 600dpi PS: 600 x 600dpi x 1bit 600 x 600dpi x 4bit 9,600 (equivalent) x 600dpi

\*1: Resolution: 600dpi (default)

\*2: The Dither and Error Diffusion methods using 8 bit input will be performed.

#### (5) Scanner section

##### a. Resolution/Gradation

Scanning Resolution (dpi)		Monochrome	Color
		Platen	600 x 600dpi 600 x 400dpi 600 x 300dpi (default)
	RSPF	600 x 600dpi 600 x 400dpi (default)	600 x 600dpi
Exposure lamp	White LED		
Reading gradation	10bit		
Output gradation	BW: 1bit Grayscale: 8bit Full Color: each color RGB 8bit		

##### b. Document table

Type	Document table fixed system (Flat bed)
Scanning area	297 x 432mm
Original standard position	Left rear reference
Detection	Yes
Detection size	Automatic detection (One type of detection unit to be switched for software destination)
Dehumidifying heater (Scanner section)	Supplied as a service parts

#### (6) Document feeder

Type	RSPF (Reversing single pass feeder)	
Scan speed	Monochrome (A4/8.5" x 11")	Color (A4/8.5" x 11")
Copy	Single: 50-sheet/min. (600 x 400dpi, 4bit) 36-sheet/min. (600 x 600dpi, 4bit) Double: 20-page/min. (600 x 400dpi, 4bit) 17-page/min. (600 x 600dpi, 4bit)	Single: 36-sheet/min. (600 x 600dpi, 4bit) Double: 17-page/min. (600 x 600dpi, 4bit)
FAX	Single: 50-sheet/min. (200 x 200dpi, 1bit) Double: 20-page/min. (200 x 200dpi, 1bit)	NA

Internet FAX	Single: 50-sheet/min. (200 x 200dpi, 1bit) Double: 20-page/min. (200 x 200dpi, 1bit)	NA
Scanner	Single: 50-sheet/min. (200 x 200dpi, 1bit) Double: 20-page/min. (200 x 200dpi, 1bit)	Single: 50-sheet/min. (200 x 200dpi, 8bit) Double: 20-page/min. (200 x 200dpi, 8bit)
Original setup direction	Upward standard (1 to N feeding standard)	
Original standard position	Center standard (Rear one-side standard for random feeding)	
Original transport method	Sheet-through method	
Original size	Standard size Inch-1: 11" x 17", 8.5" x 14", 8.5" x 11", 8.5" x 11"R, 5.5" x 8.5", A3, A4 Inch-2: 11" x 17", 8.5" x 13", 8.5" x 11", 8.5" x 11"R, 5.5" x 8.5", A3, A4 Inch-3: 11" x 17", 8.5" x 13.4", 8.5" x 11", 8.5" x 11"R, 5.5" x 8.5", A3, A4 AB-1: 11" x 17", 8.5" x 14", 8.5" x 11", A3, B4, A4, A4R, B5, B5R, A5 AB-2: 11" x 17", 8.5" x 13", 8.5" x 11", A3, B4, A4, A4R, B5, B5R, A5 AB-3: 11" x 17", 8.5" x 13", 8.5" x 11", A3, B4, A4, A4R, A5, 8K, 16K, 16KR AB-4: 11" x 17", 8.5" x 13.4", 8.5" x 11", A3, B4, A4, A4R, B5, B5R, A5 AB-5: 11" x 17", 8.5" x 13.5", 8.5" x 11", A3, B4, A4, A4R, B5, B5R, A5	
Long paper	1000 mm (Monochrome binary only) Internet Fax 600 x 600 dpi: Max. 800 mm. When scan 400 dpi or more, long paper is not available.	
Mix paper feed (Same series, same width paper)	Enabled	
Random feeding (feeding of different types / different widths)	Enabled Only the following combinations of 2 size types are allowed: A3 and B4; B4 and A4R; A4 and B5; B5 and A5; and 11-inch and 8.5-inch. AMS available. 2-sided scanning is disabled during random feeding.	
Original copy weight	Single: Thin paper: 9 - 13 lb bond (35 - 49 g/m <sup>2</sup> ) Plain paper: 13 - 32 lb bond (50 - 128 g/m <sup>2</sup> ) * Thin paper mode (39 pages/minute (A4, 8.5" x 11", 600 x 400dpi) / 26 pages/minute (A4, 8.5" x 11", 600 x 600dpi) is set up for the thin paper. Duplex: 13 - 28 lb bond (50 - 105 g/m <sup>2</sup> )	
Max. loading capacity of documents	Max. 100 sheets (21lbs Bond, 80g/m <sup>2</sup> ), or Max. height: 1/2 inch, 13mm or less	
Un-acceptable originals for feeding.	OHP, second original paper, tracing paper, carbon paper, thermal paper, paper with wrinkles, folds, or breakage, pasted paper, cutout document, document printed with ink ribbon, documents with perforation other than 2- or 3-holes (Perforated document by punch unit is allowed.)	
Detection	Yes	
Paper detection size	Auto detection	
Paper feeding direction	Right hand feeding	
Finish stamp	Option	

## (7) Paper feed section

### a. Basic specifications

Type	Standard	1-stage paper feed tray + multi manual paper feed tray
	Full option	4-stage paper feed tray + multi manual paper feed tray
Dehumidifying heater	Service parts (Supported by kit)	

Tray	Tray 1	Manual paper feed tray
Paper capacity Plain paper (80g/m <sup>2</sup> )	500 sheets	100 sheets
Paper size	Refer to the separate table of feedable paper type.	
Paper size detection	No (Guide adjustment and size input)	Yes
Paper type settings	Yes	
Changing of paper size	Switched by users	
Universal handle	Yes (With the handle lock mechanism)	-
Default Paper Size Setting	A4 (8.5" x 11")	-
Paper remaining quantity detection	Paper empty and 3 steps (100%, 67%, 33%, and paper empty)	Only detection of paper empty
Paper size display window	Yes	-

### b. Extra paper capacity

Paper type	Paper feed tray	Manual feed tray
Postcard	NA	20 sheets
Envelope	NA	20 sheets
OHP	NA	20 sheets
Heavy paper	200 sheets	40 sheets
Tab paper	NA	20 sheets
Glossy paper	NA	1 sheet
Others	NA	1 sheet

### c. Size of paper which can be fed

Paper feed section			Main unit tray	Optional Drawer				Manual paper feed tray
			Tray 1	Tray 2	Tray 3	Tray 4		
Paper size	12" x 18" (A3W)		-	-	-	-	Yes	
	11" x 17"		Yes	Yes	Yes	Yes	Yes	
	8.5" x 14" (216 x 356)		Yes	Yes	Yes	Yes	Yes	
	8.5" x 13.5" (216 x 343)		Yes	Yes	Yes	Yes	Yes	
	8.5" x 13.4" (216 x 340)		Yes	Yes	Yes	Yes	Yes	
	8.5" x 13" (216 x 330)		Yes	Yes	Yes	Yes	Yes	
	8.5" x 11"		Yes	Yes	Yes	Yes	Yes	
	8.5" x 11"R		Yes	Yes	Yes	Yes	Yes	
	7.25" x 10.5"R		Yes	Yes	Yes	Yes	Yes	
	5.5" x 8.5"R		Yes	Yes	Yes	Yes	Yes	
	A3		Yes	Yes	Yes	Yes	Yes	
	B4		Yes	Yes	Yes	Yes	Yes	
	A4		Yes	Yes	Yes	Yes	Yes	
	A4R		Yes	Yes	Yes	Yes	Yes	
	B5		Yes	Yes	Yes	Yes	Yes	
	B5R		Yes	Yes	Yes	Yes	Yes	
	A5R		Yes	Yes	Yes	Yes	Yes	
	8K		Yes	Yes	Yes	Yes	Yes	
	16K		Yes	Yes	Yes	Yes	Yes	
	16KR		Yes	Yes	Yes	Yes	Yes	
JPC *1		-	-	-	-	Yes		
Envelope		-	-	-	-	Yes		
Custom		Yes	Yes	-	-	Yes		

Paper feed section			Main unit tray	Optional Drawer			Manual paper feed tray
			Tray 1	Tray 2	Tray 3	Tray 4	
Paper type	Thin paper	13-16lb bond (55-59g/m <sup>2</sup> )	No	No	No	No	Yes
	Plain paper	16-28lb bond (60-105g/m <sup>2</sup> )	Yes	Yes	Yes	Yes	Yes
		Recycled paper	Yes	Yes	Yes	Yes	Yes
		Color paper	Yes	Yes	Yes	Yes	Yes
		Letter head	Yes	Yes	Yes	Yes	Yes
		Pre printed	Yes	Yes	Yes	Yes	Yes
		Pre Punched	Yes	Yes	Yes	Yes	Yes
	Heavy paper	28lb bond - 110lb index (106-209g/m <sup>2</sup> )	Yes	Yes	Yes	Yes	Yes
		110lb index-140lb index (210-256g/m <sup>2</sup> )	-	-	-	-	Yes
	Envelope	75-90g/m <sup>2</sup>	-	-	-	-	Yes
	OHP Transparency		-	-	-	-	Yes
	Label		-	-	-	-	Yes
	Tab paper		-	-	-	-	Yes
	Grossy paper		-	-	-	-	Yes
	User settings 1 - 7		Yes	Yes	Yes	Yes	Yes

\*1: Japan only

## (8) Paper exit section

### a. Exit Capacity

Exit location	Center	Right side (option)
Exit Capacity	400 sheets (A4/8.5" x 11": 80g/m <sup>3</sup> )	100 sheets (A4/8.5" x 11": 80g/m <sup>3</sup> )

### b. Size of paper which can be discharged

Paper exit section			Duplex	Main unit center tray		Right exit tray
				Exit tray	Off set	
Paper size	12" x 18" (A3W)		-	Yes *2	-	Yes
	11" x 17"		Yes	Yes	Yes	Yes
	8.5" x 14" (216 x 356)		Yes	Yes	Yes	Yes
	8.5" x 13.5" (216 x 343)		Yes	Yes	Yes	Yes
	8.5" x 13.4" (216 x 340)		Yes	Yes	Yes	Yes
	8.5" x 13" (216 x 330)		Yes	Yes	Yes	Yes
	8.5" x 11"		Yes	Yes	Yes	Yes
	8.5" x 11"R		Yes	Yes	Yes	Yes
	7.25" x 10.5"R		-	Yes	Yes	Yes
	5.5" x 8.5"R		Yes	Yes	Yes	Yes
	A3		Yes	Yes	Yes	Yes
	B4		Yes	Yes	Yes	Yes
	A4		Yes	Yes	Yes	Yes
	A4R		Yes	Yes	Yes	Yes
	B5		Yes	Yes	Yes	Yes
	B5R		Yes	Yes	Yes	Yes
	A5R		Yes	Yes	Yes	Yes
	8K		Yes	Yes	Yes	Yes
	16K		Yes	Yes	Yes	Yes
	16KR		Yes	Yes	Yes	Yes
JPC *1		-	Yes	Yes	Yes	
Envelope		-	Yes	-	-	
Custom		Yes	Yes	-	Yes	
Paper type	Thin paper	13-16lb bond (55-59g/m <sup>2</sup> )	-	Yes	Yes	Yes
	Plain paper	16-28lb bond (60-105g/m <sup>2</sup> )	Yes	Yes	Yes	Yes
		Recycled paper	Yes	Yes	Yes	Yes
		Color paper	Yes	Yes	Yes	Yes
		Letter head	Yes	Yes	Yes	Yes
		Pre printed	Yes	Yes	Yes	Yes
		Pre Punched	Yes	Yes	Yes	Yes
	Heavy paper	28lb bond - 110lb index (106-209g/m <sup>2</sup> )	Yes	Yes	Yes	Yes
		110lb index - 140lb index (210-256g/m <sup>2</sup> )	-	Yes	Yes	Yes
	Envelope	75-90g/m <sup>2</sup>	-	Yes	-	-
	OHP Transparency		-	Yes	-	Yes
	Label		-	Yes	-	Yes
	Tab paper		-	Yes	-	-
	Grossy paper		-	Yes	Yes	-
	User settings 1 - 7		Yes	Yes	Yes	Yes

\*1: Japan only

\*2: Except North America

## (9) Operation panel

Size	7 inch
Type	Dot matrix LCD, touch panel
Display dot number	800 x 480 dots (WVGA)
LCD back-light	LED lamp back-light system

## (10) Controller board

CPU	ARM11: 600MHz ARM9: 400MHz/during 1W energy save mode: 75MHz
PCL accelerator (OPT)	MPC8535 Power QUICC e500 800MHz
Interface	
Ethernet	1port
Interface	10Base-T, 100Base-TX, 1000Base-T
Support Protocol	TCP/IP (IPv4, IPv6), IPX/SPX, NetBEUI, EtherTalk
USB 2.0 (high speed) (host)	2port (Simultaneous use of the front/rear ports is enable.)
USB 2.0 (high speed) (device)	1port
USB-HUB (host)	Internal: 4port • For Front USB Port • For Rear USB Port • Reserved • Reserved
Serial I/F	1port
Memory	See the section "Memory/Hard disk".
Memory slot	Main unit: 2 slot (1 slot: empty) PCL (OPT): 2 slot (1 slot: empty)

## (11) Memory/Hard disk

SD card	MFP control PWB	Printer control PWB*1		HDD*2
	SLOT1	SLOT3	SLOT4	
4GB	1GB (STD)	512MB (STD)	1GB (OPT)	160GB (STD)

\*1: Memory capacity of Printer Expansion Kit (OPT) controller

\*2: HDD capacity depends on procurement and sourcing status.

Memory area (SD card)	Boot/Program area
	FAX data storage area 1GB

## (12) Warm-up time

	Main power SW
Warm-up time*1	20sec. or less
Pre heat	Yes
Jam recovery time*2	37sec. or less

\*1: Result may change depending on conditions.

\*2: Conditions: Leave the machine for 60 sec. after door open, standard condition, Polygon stops.

## B. Copy functions

### (1) First copy time

Engine	21cpm machine		31cpm(G) machine	
	Mono-chrome	Color	Mono-chrome	Color
Platen	7.4 sec.	10.0 sec.	5.8 sec.	7.9 sec.
RSPF	10.0 sec.	13.2 sec.	9.1 sec.	11.6 sec.

### (2) Job Speed

Engine	21cpm machine		31cpm(G) machine	
	Mono-chrome	Color	Mono-chrome	Color
S to S	23cpm (100%)	23cpm (100%)	31cpm (100%)	31cpm (100%)

### (3) Job Effectiveness

BLI Standard (RSPF)

Engine	21cpm machine		31cpm(G) machine	
	Mono-chrome	Color	Mono-chrome	Color
S to S	22cpm (96%)	21cpm (91%)	28cpm (90%)	28cpm (90%)
S to D	21cpm (91%)	20cpm (87%)	26cpm (84%)	25cpm (81%)
D to D	21cpm (91%)	20cpm (87%)	27cpm (87%)	25cpm (80%)

\* S to S: 10 pages of A4 / 8.5" x 11" document and 5 copies

\* S to D: 10 pages of A4 / 8.5" x 11" document and 5 copies

\* D to D: 10 pages (20 sides) of A4 / 8.5" x 11" document and 5 copies

## C. Printer function

### (1) Printer driver supported OS

OS	Custom PCL6	Custom PS	PPD	Sharp Advanced Printing Language	PC-FAX
Windows	2000	CD-ROM	CD-ROM	CD-ROM	CD-ROM
	XP	CD-ROM	CD-ROM	CD-ROM	CD-ROM
	XP (x 64)	CD-ROM	CD-ROM	CD-ROM	CD-ROM
	Server 2003	CD-ROM	CD-ROM	CD-ROM	CD-ROM
	Server 2003 (x 64)	CD-ROM	CD-ROM	CD-ROM	CD-ROM
	Vista	CD-ROM	CD-ROM	CD-ROM	CD-ROM
	Vista (x 64)	CD-ROM	CD-ROM	CD-ROM	CD-ROM
	Server 2008	CD-ROM	CD-ROM	CD-ROM	CD-ROM
	Server 2008 (x 64)	CD-ROM	CD-ROM	CD-ROM	CD-ROM
	Windows 7	CD-ROM	CD-ROM	CD-ROM	CD-ROM
Windows 7 (x 64)	CD-ROM	CD-ROM	CD-ROM	CD-ROM	
Mac	9.0-9.2.2	No	No	Web	No
	X 10.2.8	No	No	Web	No
	X 10.3.9	No	No	Web	No
	X 10.4.11	No	No	CD-ROM	No
	X 10.5-10.5.8	No	No	CD-ROM	No
	X 10.6-10.6.5	No	No	CD-ROM	No



## (2) PDL emulation/Font

PDL (Command)		Installed font	Option font
PCL6 compatibility	OPT	European outline font = 80 styles Line printer font (BMP) = 1 style	Barcode font = 28 styles
Postscript3 compatibility	OPT	-	European outline font = 136 styles

## D. FAX function

### (1) Transmission method

Transmission time	Less than 3 sec (Super G3) Less than 7 sec (G3 ECM)
Compression/ expansion system	MH, MR, MMR, JBIG (Fixed to ECM for MMR or JBIG.)
Modem speed	33.6kbps → 2.4kbps automatic fallback
Resolution	8 x 3.85 line/mm, 8 x 7.7 line/mm, 8.15.4 line/mm, 16 x 15.4 line/mm (Standard memory is used for transmit/receive.)
Intercommunication	G3/Super G3: Standard (V.34, V.17, V.33, V.29, V.27ter)
Communication line	General telephone line (PSTN), ISDN (When TA is installed.) Private Branch Exchange (PBX)
ECM	Yes

### (2) Number of Support Line

Standard	1 line
Expansion	Not provided

### (3) Transmission Mode

RSPF/OC transmission switching	Yes (Switching during the reading is not feasible)
-----------------------------------	--

### (4) Image Quality/Image Process

Half tone reproduction	Equivalent to 256 levels (Valid only when monochrome document is scanned.)
Exposure adjustment	Auto / Manual (5 steps)
FAX quality selection	Standard (8 x 3.85 lines/mm (203.2 x 97.8dpi)) Fine (8 x 7.7 lines/mm (203.2 x 195.6dpi)) Super Fine (8 x 15.4 lines/mm (203.2 x 391dpi)) Ultra Fine (16 x 15.4 lines/mm (406.4 x 391dpi)) Half-tone (Combination with normal character is invalid.)

### (5) Record Size

Max. record width	293mm
Record size	(AB series) A3, B4, A4, A4R, B5, B5R, A5R (Inch series) 11 x 17, 8.5 x 13, 8.5 x 14, 8.5 x 11, 8.5 x 11R, 8.5 x 5.5R

\* If the document length exceeds A3 size, it is divided and printed.

\* For printing the list, A5R and 8.5 x 5.5R cannot be used.

### (6) Dial

Manual dialing	To be entered by 10-key, # key, * key
Re-dialing	The previous 8 items (max.) can be saved, and one of them can be selected. One-touch call is available.
One-touch dialing	1000 items including the group dialing items
Group dialing	1000 items including the one-touch dialing items
Program dialing	Max. 48 items
Chain dialing	Max. 64 digits including one-touch dialing, 10-key dialing, and pause.
Dial search	Alphabet order search, User index groups
Quick search	Yes
LDAP search	Yes
Sub address	Yes
Password	Yes
Memory box registration	Yes

\* LDAP: Lightweight Directory Access protocol

### (7) Memory for Transmit/Receive

FAX transmission data	HDD
FAX reception data	SD card

### (8) Function

Transmit function	Calling function	Yes Requires the frequency setting for each destination.
	PBX function	Germany, France only
	Memory transmit	Yes (Definable destinations : 94 destinations)
	On-hook	Yes
	Quick online transmit	Yes
	Direct transmit	Yes
	Manual transmit	Yes
	Auto re-call mode	Yes
	Time indication function	Yes
	Sequential broadcasting function	Yes
	F code interface broadcasting indication function	Yes Only one interface station can be specified.
	F code interface broadcasting function	Yes
	F code confidential send function	Yes
	Polling	Yes Even with another company machine
	Sequential polling function	Yes Even with another company machine
	F-code polling	Yes
	Bulletin board	Yes
	F code bulletin board function	Yes
	Auto reduction transmit	Yes A3 → B4, A3 → A4, B4 → A4
	Rotation transmit	Yes Counterclockwise rotation of 90 degrees
Duplex transmit	Yes	
Document transmit from OC function	Yes	

Transmit function	Long length original transmit	Only when RSPF is used. Transmission is enable up to 1000mm.
	Mixed documents function	Only when RSPF is used.
	Zoom transmit	Yes
	2 in 1 transmit	Yes
	Card shot transmit	Only when transmitting from OC
	Thin paper scan function	Available except for duplex scan
	Edge erase transmit function	Yes Only for the fixed sizes
	Job build	Yes
	Page division transmit	Yes
	Cover	No
	Index	No
	Transmit message adding function	No
	Receive function	Auto receive
Manual receive		Yes
DRD call function		Distinctive Ring Detection North America: Standard, Pattern 1 – 5 Australia/New Zealand/Hong Kong: ON/OFF (TEL/FAX)
Memory receive		Yes
Transfer function		Yes Number of registration: 1 item
Specified receive function		Yes (Number of registration) Rejection numbers: Max.50 items
Receive data print condition function		Yes
Receive function	Receive data staple setting/ Copy number setting	Yes
	Rotation receive	Yes Output by clockwise rotation of 90 degrees
	Divided receive	Yes Divided print is not made in duplex mode.
	Duplex receive	Yes
	F-code confidential receive	Yes
Special function	Print hold	Yes
	Document Admin	Yes
	Inbound Routing	Yes
	Sender registration function	Yes
	Sender print function	Yes
	On-hook dialing function	Yes
	Retransmit function	Yes
	Pause function	Yes Pause time is 1 – 15 sec.
	Sound volume setting function	Yes
	Tone pulse select function	Tone, Pulse, Auto (North America/Taiwan) * For the other destinations, set with the soft switch.
	External phone connection	Yes
	Memory remaining capacity check function	Yes Only the integral part is displayed.
	Back up	Yes
	Registered data read/write function	Yes
	Report/List	Yes
	Destination check function	Yes
	Broadcasting destination display function	Yes
	Transmit job change function	Yes
Save-energy function	Yes	
Line monitor display function	Yes	

Special function	FAST	Yes Facsimile Automated Service Technology
	Time adjust function	Yes Summer time ON/OFF
	PC-FAX	Yes
	Color mode	No
	Sender registration function	Yes Number of registration: 1 for standard sender name and address. And 18 sender names can be registered.
	Default destination setting	No
	Unauthorized scan prevention function	Yes
	Filing-each-page function	No
	Re-operation function	Yes
	User account function	Yes Max. 200 items additionally to the default
	Counter function	Yes

## E. Image send function

### (1) Mode

FAX	FAX to e-mail/FTP
-----	-------------------

### (2) System environment

Copier memory (Local memory)	Printer memory (System Memory)
1GB (Standard)	512MB (Standard)

### (3) Image send function (Push send from the main unit)

#### a. Support image

Mode	FAX
Compression method	MH, MR, MMR, JBIG

#### b. Image processing

Mode	FAX
Original scanning color	B/W
Half-tone reproduction	Equivalent of 256 steps
Density adjustment	Auto + 5 steps
Selection of image quality	Half tone (Black-white only) ON/OFF
Resolution (depends on file format/transmission method)	Standard character (203.2 x 97.8dpi) (half tone not allowed) Fine (203.2 x 195.6dpi) Super fine (203.2 x 391dpi) Ultra fine (406.4 x 391dpi)

#### c. Specification of Addresses

Mode	FAX
Address specification	Specification by one-touch/group/ direct address entry. Entry from 10-key. (Fax) Selection from LDAP server
Number of One-touch address key registration	Total (number of key): Maximum 1000
Number of Group (1 key) address registration	Number of Group (1 key) address registration : maximum 500 Number of Group key registration : 5000 (Total address number included in /1000 key)
Program	48
Direct entry of addresses	Entry by 10-key, # key
Chain dial	Yes (pause key)
Resend	Call up nearest 8 addresses. *1
Destination confirmation	Yes
Shortcut for address selection (quick key)	Use the 10-key to call up registered numbers of addresses.

Mode	FAX
Disable direct entry transmission *2	Yes
Disable PC- Fax sending	Yes

\*1: Except for FTP, Desktop, SMB, USB memory, Broadcast.

\*2: When disabled, the address registration is not allowed either.

#### d. Specification of Multiple Addresses

Mode	FAX
Broadcast	Yes (500 destinations)
Request of serial transmission	Yes

\* Broadcast transmission is allowed. (Monochrome only)

#### e. Transmission function

Mode	FAX	
Memory transmission	94 destinations in all	
On-hook	Yes	
Quick online transmission	Yes	
Direct transmission	Yes (Switching: Memory transmission ↔ Direct transmission)	
Automatically-reduced transmission	Yes	
Rotated transmission	Yes	
Scaled transmission	Yes Enlargement/reduction is allowed only from a fixed size to another. Reduction may be done on the receiver side with Fax/Internet Fax sending.	
Recall mode	Error	Yes
	Busy	Yes
	Number/time to be set up through system setup	
Long original transmission	Yes Maximum of 1000mm (single side only/black-white 2 values only)	
Confidential transmission (Sharp mode)	No	
Relay broadcast transmission (Sharp mode)	No	
Large capacity original mode	Yes	
Scanning of thin paper	Yes	
Mixed originals feeder	Yes (Random + MIX)	
Default date sender transmission	Yes (ON only)	
Preview	No	
Side erase	Yes	

#### f. Reception function

Mode	FAX
Automatic reception	Yes
Manual reception	No Switching from manual reception to automatic reception. (Allowed only for France and Japan)
Memory reception	Yes
Fixed size reduced reception	Yes
Specified size scaled reception	No
Rotated reception	Yes
Setting of received data print condition	Equal size print (partition not allowed) Equal size print (partition allowed) Equal or reduced size print
2-sided reception	Condition setting through system setting
2-in-1 reception	No
Automatic reduction setting upon receiving A3	Yes
Automatic reduction setting upon receiving letter	Yes (Other than North America and Inch destinations)
Reception from a specific number not allowed, or allowed. (Allow/Reject)	Specified numbers only (50 numbers /20 digits)

Mode	FAX
External phone connection remote	Yes
Confidential reception (Sharp mode)	No
Received data bypass output	Yes
Index printing	No
Transfer function upon disabling of output.	Yes (1 receiver (of transfer) registration)
Internet Fax/Fax to e-mail (Transfer of Internet Fax/Fax reception data to e-mail, inbound routing)	Yes
Exit tray setting	Yes
Insertion of job separator sheet	No
Staple function of received data	Yes
Auto wake up print	Yes
Received data print hold *1	Yes
Color toner print when black toner runs out.	No

\*1: This function saves all received data in memory and starts output after password entry. (Confidential reception is excluded.) Setting only on the receiver side.

#### g. Report/list function

Mode	FAX
Image sending activity report	Yes Time-specified output Output with memory full * Maximum of 200 times including both transmission and reception
Transaction report	Yes
Address/phone number table	Yes
Group table	Yes
Program table	Yes
Memory box table (F code)	Yes
Communication original contents print	Always print/Upon error/no print
List of allowed or rejected reception numbers	Yes
Table of control record for each account	No

#### h. Other Functions

Mode	FAX
Time specification	Yes
Polling reception	Yes
Bulletin board transmission	Yes Up to 100 registrations allowed with bulletin board, confidential and relay broadcast all combined. (Free area : 1 registration) Setting of the number of transmission: 1/no limit.
Cover sheet function	No
Transmission message	No
Sender print	Yes
Sender selection	Yes
Page number print	Yes
Date print	Yes (Date can be expressed alternatively)
Polling protection function	Yes
Page partition transmission	Yes
Page connection	No
Confidential (receiver unit)	Yes (F code method)
Relay broadcast instructions	Yes (F code method)
Fax to e-mail (F code) *1	Yes
Edge erase	Yes
Center erase	Yes
2 in 1	Yes

Mode	FAX
Card shot	Yes (Equivalent or enlargement up to the paper width. The maximum enlargement is not allowed to exceed 400%)
Forward data transmission/reception (Document Admin)	Yes Data transmission by PC-Fax/ PC-Internet Fax is allowed, too.

\*1: This function means that e-mail address setting on F code relay broadcast allowed.

#### i. Transmission Method

Mode	FAX
Transmission time	2 seconds level (super G3/JBIG), 6 seconds level (G3 ECM)
Modem speed	Automatic fall-back : 33.6kbps → 2.4kbps
Intercommunication	Super G3/G3
Communication line	General membership telephone line (PSTN), independent business line (PBX), F net. (R-key for PBX setting: Germany/France)
ECM	Yes

#### j. Record Size

Mode	FAX
Maximum record width	293mm
Record size	A3 – A5/11 x 17 – 5.5 x 8.5

#### k. F code communication

Mode	FAX
Sub-address	Yes (20 digits)
Password	Yes (20 digits)

#### l. Registration-related settings

Mode	FAX
One-touch/group *1 E-mail FTP Desktop SMB FAX	1000 destinations Use of LDAP allowed Up to 500 registered addresses for each group dial. Registered name in 18 full-size character (36 half-size characters) One-touch dial receiver number registration: within 64 digits for receiver number + sub-address + passcode (including "/").
Program	Registration of addresses (groups), settings (density, image quality) and special functions in one set is allowed. (48 of them)
Number of memory boxes	Registration of bulletin board/confidential/relay broadcast is allowed up to 100. Registration name: 18 characters
Number of sender registration	1 (default) with 20 characters
Number of sender selection registration	Total: 18 registrations (20 characters) (Sender selection: In addition to default, 18 registrations allowed)
Registration of polling approval number	10 numbers/20 digits
Registration of Fax system number (Sharp mode)	No
Registration of Fax polling approval ID number (Sharp mode)	No
Fax relay ID registration (Sharp mode)	No
Quick key (short cut registration) *2	Yes (001 – 1000)
Import/export of address book	Yes (By storage backup)
Black list (for France)	No

\*1: Since scan/Internet Fax/Fax uses the common address book, the number of addresses allowed for registration is the sum total of all modes.

\*2: Quick key is the function to select an address based on the registered number of each address within the book for address selection. Users should be able to select a quick key number.

#### m. Telephone functions

Mode	FAX
On-hook function	Yes
Hold	No
Setting of pause time	Yes (1 – 15 seconds)
Telephone transmission during power outage	No (External telephone transmission allowed)
Tone pulse switching	Tone, Pulse, Auto (North America/Taiwan) * For the other destinations, set with the soft switch.

#### n. Sound settings

Mode	Item	FAX
On-hook sound	Sound volume setting	1 - 9
Sound volume for calling	Sound volume setting	1 - 9, No
Line monitor sound	Sound volume setting	1 - 9, No
Reception sound	Sound volume setting	1 - 9, No
Transmission success sound	Sound volume setting	1 - 9, No
Transmission and reception error sound	Sound volume setting	1 - 9, No
Sound setting for end of original reading (image send)	Sound volume setting	Large/middle/small/no sound

#### o. Others

Mode	FAX
PC-FAX	Yes
FAST	Yes (SEC only)
Network FAST	No
Distinctive ring detection	Setting for each destination

#### F. Power consumption

The full configuration can be operated with the rated power source.

Maximum rated power Consumption*1	100 V	200 V
	1.44 kW	1.84 kW
Energy consumption rate	Not applicable	
TEC value (Measured result)	23cpm machine: 1.8kWh 31cpm(G) machine: 4.7kWh	23cpm machine: 1.72kWh 31cpm(G) machine: 2.51kWh
TEC value (Standard) Tier2	23cpm machine: 5.80 kWh (0.1 kwh*23 + 3.5 kwh) 31cpm(G) machine: 7.85 kWh (0.35 kwh*31 - 3 kwh)	
Network/Fax waiting power consumption	1 W Condition: • No USB port • The network protocol is TCP/IP only. • The Ethernet connection partner supports 10M/100MBASE or 10M/100M/1000MBASE and auto negotiation setting. * Exclude the case of use Fax and Network at once) * North America Default : Wake up mode	–
Moving time to pre-heat mode	1 minutes (default)	
Recovery time from pre-heat mode	10 sec.	

Moving time to sleep mode	1 minutes (default) * Printer mode: 10sec.(default)
Recovery time from sleep mode	20 sec.

\*1: Power switch ON, dehumidity heater OFF

## G. Dimensions and Weight

Outer dimension (Included operation panel)	W583 x D623 x H834mm
Footprint	W583 x 623mm (Included right exit tray) W831 x 623mm (Excluded right exit tray)
Dimension occupied by the machine (When the bypass tray is extended)	W964 x D623mm (When the right paper exit tray is extended.)
Weight Main Unit (including photoreceptor / not including consumables)	73.9kg (With the right paper exit tray: 74.3kg)

## H. Ambient conditions

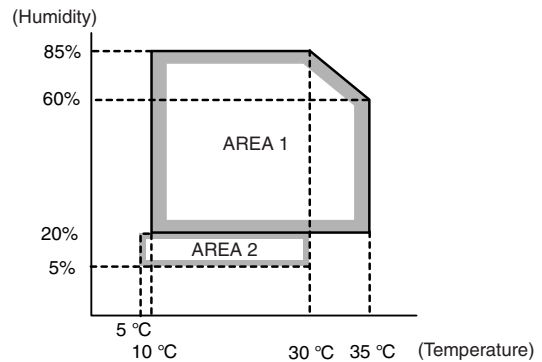

## 3. 26cpm/36cpm/31cpm(A) machine

### A. Basic specifications

#### (1) Engine Specification

Photo-conductor kind	OPC (Diameter: Black: $\phi$ 30mm Color (Y/M/C): $\phi$ 30mm x3 lines)
Copying method	Electronic photo (Laser)
Developing system	Dry, 2-component magnetic brush development
Charging system	Charged saw-tooth method
Transfer system	Intermediate/secondary transfer belt
Separation system	Natural separation method * Sub separation claw is equipped.
Cleaning system	Counter blade
Fusing system	Belt method
Waste toner disposal	No toner recycling system / Waste toner bottle system
Toner supply during operation	N/A
Outer Color	Pastel white, natural wave design

#### (2) Engine speed (ppm)

##### Tray 1 - 5

Paper size	26cpm machine		31cpm(A) machine		36cpm machine	
	Monochrome	Color	Monochrome	Color	Monochrome	Color
A3, 11" x 17", 8K	14	14	15	15	17	17
B4, 8.5" x 14", 8.5" x 13", 8.5" x 13.4", 8.5" x 13.5"	16	16	17	17	20	20
A4, B5, 8.5" x 11", 16K	26	26	31	31	36	36
A4R, 16KR, 8.5" x 11"R, B5, 7.25" x 10.5"R	19	19	20	20	23	23
A5R, 5.5" x 8.5"R	19	19	20	20	27	27
Extra	13	13	14	14	16	16
Heavy paper (A3, 11" x 17", 8K)	7	7	7	7	8	8
Heavy paper (B4, 8.5" x 14", 8.5" x 13", 8.5" x 13.4", 8.5" x 13.5")	7	7	7	7	8	8
Heavy paper (A4, B5, 8.5" x 11", 16K)	12	12	12	12	14	14
Heavy paper (A4R, B5R, 8.5" x 11"R, 7.25" x 10.5"R, 16KR)	9	9	9	9	11	11
Heavy paper (A5R, 5.5" x 8.5"R)	12	12	12	12	14	14
Heavy paper (Extra)	7	7	7	7	8	8

## Manual paper feed

Paper size	26cpm machine		31cpm(A) machine		36cpm machine	
	Monochrome	Color	Monochrome	Color	Monochrome	Color
A3, 11" x 17", 8K	14	14	15	14	17	17
B4, 8.5" x 14", 8.5" x 13", 8.5" x 13.4", 8.5" x 13.5"	16	16	17	16	20	20
A4, 8.5" x 11", 16K	26	23	26	23	31	31
B5	26	26	26	26	31	31
A4R, 16KR, 8.5" x 11"R	19	19	20	19	23	23
B5R, 7.25" x 10.5"R	19	19	20	20	23	23
A5R, 5.5" x 8.5"R	19	19	20	20	27	27
A3W, 12" x 18" *2	13	13	14	13	16	16
OHP (A4, 8.5" x 11")	12	11	12	11	14	14
OHP (A4R, 8.5" x 11"R)	9	9	9	9	11	11
Extra	13	13	14	13	16	16
Envelope (Monarch, Com-10, DL, C5, Chokey-3, Chokey-4, Youkei-2, Youkei-4, Kakugata-2, Kakugata-3)	8	7	8	7	10	10
Heavy paper (A3, 11 x 17, 8K)	7	6	7	6	8	8
Heavy paper (B4, 8.5" x 14", 8.5" x 13", 8.5" x 13.4", 8.5" x 13.5")	7	6	7	6	8	8
Heavy paper (A4, 8.5" x 11", 16K, B5)	12	11	12	11	14	14
Heavy paper (A4R, 16KR, 8.5" x 11"R, B5R, 7.25" x 10.5"R)	9	9	9	9	11	11
Heavy paper (A5R, 5.5" x 8.5"R)	12	11	12	11	14	14
Heavy paper (A3W, 12 x 18) *1	7	6	7	6	8	8
Heavy paper (Extra)	7	6	7	6	8	8
Heavy paper (Post Card HIGH) *2	12	12	12	12	14	14
Heavy paper (Post Card LOW) *2	7	7	7	7	8	8

\*1: ppm when exiting to the finisher (A3W/12" x 18" cannot exit to the center tray)

\*2: Switched by the service simulation setting. Postcard is set Low before shipment.

### (3) Printable area

A3 Wide *1	297 x 420mm	12" x 18" *1	279 x 432mm
A3	293 x 413mm	11" x 17"	275 x 425mm
B4	253 x 357mm	8.5" x 14"	212 x 349mm
A4	206 x 290mm	8.5" x 13.5"	212 x 336mm
B5	178 x 250mm	8.5" x 13.4"	212 x 333mm
A5	144 x 203mm	8.5" x 13"	212 x 323mm
Postcard	96 x 141mm	Executive	180 x 260mm
8K	266 x 383mm	8.5" x 11"	212 x 272mm
16K	191 x 263mm	5.5" x 8.5"	136 x 209mm
Custom	Min: 96mm x 141mm Max: 297mm x 432mm		

\*1: The printable area for A3W/12" x 18" must be as large as the A3/11" x 17" page full bleed (299 x 450mm).

Void area	Lead edge: 4mm or less
Image loss	Rear edge: 2 mm or more, and 5 mm or less Total of the lead edge and the rear edge: 8mm or less FR total: 4mm±2mm or less

### (4) Engine resolution

Resolution*1	Copy	Writing 600 x 600dpi 9,600 (equivalent) x 600dpi
	Print	Writing 600 x 600dpi 9,600 (equivalent) x 600dpi 1,200 x 1,200dpi
Gradation *2 (256 levels)	Copy	Writing 600 x 600dpi x 4bit 9,600 (equivalent) x 600dpi
	Print	Writing PCL: 600 x 600dpi x 1bit 600 x 600dpi x 4bit 9,600 (equivalent) x 600dpi 1,200 x 1,200dpi x 1bit PS: 600 x 600dpi x 1bit 600 x 600dpi x 4bit 9,600 (equivalent) x 600dpi 1,200 x 1,200dpi x 1bit

\*1: Resolution: 600dpi (default)

\*2: The Dither and Error Diffusion methods using 8 bit input will be performed.

### (5) Scanner section

#### a. Resolution/Gradation

Scanning Resolution (dpi)		Monochrome	Color
	Platen	600 x 600dpi 600 x 400dpi 600 x 300dpi (default)	600 x 600dpi
	RSPF	600 x 600dpi 600 x 400dpi (default)	600 x 600dpi
Exposure lamp	White LED		
Reading gradation	10bit		
Output gradation	BW: 1bit Gray scale: 8bit Full Color: each color RGB 8bit		

## b. Document table

Type	Document table fixed system (Flat bed)
Scanning area	297 x 432mm
Original standard position	Left top reference
Detection	Yes
Detection size	Automatic detection (One type of detection unit to be switched for software destination)
Dehumidifying heater (Scanner section)	Supplied as a service parts

## (6) Document feeder

Type	RSPF (Reversing single pass feeder)	
Scan speed	Monochrome (A4/8.5" x 11")	Color (A4/8.5" x 11")
Copy	Single: 50-sheet/min. (600 x 400dpi, 4bit) 36-sheet/min. (600 x 600dpi, 4bit) Double: 20-page/min. (600 x 400dpi, 4bit) 17-page/min. (600 x 600dpi, 4bit)	Single: 36-sheet/min. (600 x 600dpi, 4bit) Double: 17-page/min. (600 x 600dpi, 4bit)
FAX	Single: 50-sheet/min. (200 x 200dpi, 1bit) Double: 20-page/min. (200 x 200dpi, 1bit)	NA
Internet FAX	Single: 50-sheet/min. (200 x 200dpi, 1bit) Double: 20-page/min. (200 x 200dpi, 1bit)	NA
Scanner	Single: 50-sheet/min. (200 x 200dpi, 1bit) Double: 20-page/min. (200 x 200dpi, 1bit)	Single: 50-sheet/min. (200 x 200dpi, 8bit) Double: 20-page/min. (200 x 200dpi, 8bit)
Original setup direction	Upward standard (1 to N feeding standard)	
Original standard position	Center standard (Rear one-side standard for random feeding)	
Original transport method	Sheet-through method	
Original size	Standard size Inch-1: 11" x 17", 8.5" x 14", 8.5" x 11", 8.5" x 11"R, 5.5" x 8.5", A3, A4 Inch-2: 11" x 17", 8.5" x 13", 8.5" x 11", 8.5" x 11"R, 5.5" x 8.5", A3, A4 Inch-3: 11" x 17", 8.5" x 13.4", 8.5" x 11", 8.5" x 11"R, 5.5" x 8.5", A3, A4 AB-1: 11" x 17", 8.5" x 14", 8.5" x 11", A3, B4, A4, A4R, B5, B5R, A5 AB-2: 11" x 17", 8.5" x 13", 8.5" x 11", A3, B4, A4, A4R, B5, B5R, A5 AB-3: 11" x 17", 8.5" x 13", 8.5" x 11", A3, B4, A4, A4R, A5, 8K, 16K, 16KR AB-4: 11" x 17", 8.5" x 13.4", 8.5" x 11", A3, B4, A4, A4R, B5, B5R, A5 AB-5: 11" x 17", 8.5" x 13.5", 8.5" x 11", A3, B4, A4, A4R, B5, B5R, A5 Long paper   1000 mm (Monochrome binary only)	
Mix paper feed (Same series, same width paper)	Enabled	
Random feeding (feeding of different types / different widths)	Enabled Only the following combinations of 2 size types are allowed: A3 and B4; B4 and A4R; A4 and B5; B5 and A5; and 11-inch and 8.5-inch. AMS available. 2-sided scanning is disabled during random feeding.	

Original copy weight	Single: Thin paper: 9 - 13 lb bond (35 - 49 g/m <sup>2</sup> ) Plain paper: 13 - 32 lb bond (50 - 128 g/m <sup>2</sup> ) * Thin paper mode (39 pages/minute (A4, 8.5" x 11", 600 x 400dpi) / 26 pages/minute (A4, 8.5" x 11", 600 x 600dpi) is set up for the thin paper. Duplex: 13 - 28 lb bond (50 - 105 g/m <sup>2</sup> )
Max. loading capacity of documents	Max. 100 sheets (21lbs Bond, 80g/m <sup>2</sup> ), or Max. height: 1/2 inch, 13mm or less
Un-acceptable originals for feeding.	OHP, second original paper, tracing paper, carbon paper, thermal paper, paper with wrinkles, folds, or breakage, pasted paper, cutout document, document printed with ink ribbon, documents with perforation other than 2- or 3-holes (Perforated document by punch unit is allowed.)
Detection	Yes
Paper detection size	Auto detection
Paper feeding direction	Right hand feeding
Finish stamp	Option

## (7) Paper feed section

### a. Basic specifications

Type	Standard	1-stage paper feed tray + multi manual paper feed tray
	Full option	4-stage paper feed tray + multi manual paper feed tray + large capacity tray
Dehumidifying heater	Service parts (Supported by kit)	

### 26cpm/31cpm(A) machine

Tray	Tray 1	Manual paper feed tray
Paper capacity Plain paper (80g/m <sup>2</sup> )	500 sheets	100 sheets
Paper size	Refer to the separate table of feedable paper type.	
Paper size detection	No (Guide adjustment and size input)	Yes
Paper type settings	Yes	
Changing of paper size	Switched by users	
Universal handle	Yes (With the handle lock mechanism)	-
Default Paper Size Setting	A4 (8.5" x 11")	-
Paper remaining quantity detection	Paper empty and 3 steps (100%, 67%, 33%, and paper empty)	Only detection of paper empty
Paper size display window	Yes	-

### 36cpm machine

Tray	Tray 1	Manual paper feed tray
Paper capacity Plain paper (80g/m <sup>2</sup> )	500 sheets	100 sheets
Paper size	Refer to the separate table of feedable paper type.	
Paper size detection	Yes	
Paper type settings	Yes	
Changing of paper size	Switched by users	
Universal handle	Yes (With the handle lock mechanism)	-
Default Paper Size Setting	A4 (8.5" x 11")	-
Paper remaining quantity detection	Paper empty and 3 steps (100%, 67%, 33%, and paper empty)	Only detection of paper empty
Paper size display window	Yes	-

**b. Extra paper capacity**

Paper type	Paper feed tray	Manual feed tray
Postcard	NA	20 sheets
Envelope	NA	20 sheets
OHP	NA	20 sheets
Heavy paper	200 sheets	40 sheets
Tab paper	NA	20 sheets
Glossy paper	NA	1 sheet
Others	NA	1 sheet

**c. Size of paper which can be fed**

Paper feed section			Main unit tray	Optional Drawer					Manual paper feed tray
			Tray 1	Tray 2	Tray 3	Tray 4	LCC		
Paper size	12" x 18" (A3W)		-	-	-	-	-	-	Yes
	11" x 17"		Yes	Yes	Yes	Yes	-	-	Yes
	8.5" x 14" (216 x 356)		Yes	Yes	Yes	Yes	-	-	Yes
	8.5" x 13.5" (216 x 343)		Yes	Yes	Yes	Yes	-	-	Yes
	8.5" x 13.4" (216 x 340)		Yes	Yes	Yes	Yes	-	-	Yes
	8.5" x 13" (216 x 330)		Yes	Yes	Yes	Yes	-	-	Yes
	8.5" x 11"		Yes	Yes	Yes	Yes	Yes	-	Yes
	8.5" x 11"R		Yes	Yes	Yes	Yes	-	-	Yes
	7.25" x 10.5"R		Yes	Yes	Yes	Yes	-	-	Yes
	5.5" x 8.5"R		Yes	Yes	Yes	Yes	-	-	Yes
	A3		Yes	Yes	Yes	Yes	-	-	Yes
	B4		Yes	Yes	Yes	Yes	-	-	Yes
	A4		Yes	Yes	Yes	Yes	Yes	-	Yes
	A4R		Yes	Yes	Yes	Yes	-	-	Yes
	B5		Yes	Yes	Yes	Yes	Yes	-	Yes
	B5R		Yes	Yes	Yes	Yes	-	-	Yes
	A5R		Yes	Yes	Yes	Yes	-	-	Yes
	8K		Yes	Yes	Yes	Yes	-	-	Yes
	16K		Yes	Yes	Yes	Yes	-	-	Yes
	16KR		Yes	Yes	Yes	Yes	-	-	Yes
JPC *1		-	-	-	-	-	-	Yes	
Envelope		-	-	-	-	-	-	Yes	
Custom		Yes	Yes	-	-	-	-	Yes	
Paper type	Thin paper	13-16lb bond (55-59g/m <sup>2</sup> )	No	No	No	No	No	No	Yes
	Plain paper	16-28lb bond (60-105g/m <sup>2</sup> )	Yes	Yes	Yes	Yes	Yes	Yes	Yes
		Recycled paper	Yes	Yes	Yes	Yes	Yes	Yes	Yes
		Color paper	Yes	Yes	Yes	Yes	Yes	Yes	Yes
		Letter head	Yes	Yes	Yes	Yes	Yes	Yes	Yes
		Pre printed	Yes	Yes	Yes	Yes	Yes	Yes	Yes
		Pre Punched	Yes	Yes	Yes	Yes	Yes	Yes	Yes
	Heavy paper	28lb bond - 110lb index (106-209g/m <sup>2</sup> )	Yes	Yes	Yes	Yes	-	-	Yes
		110lb index-140lb index (210-256g/m <sup>2</sup> )	-	-	-	-	-	-	Yes
	Envelope	75-90g/m <sup>2</sup>	-	-	-	-	-	-	Yes
	OHP Transparency		-	-	-	-	-	-	Yes
	Label		-	-	-	-	-	-	Yes
	Tab paper		-	-	-	-	-	-	Yes
	Grossy paper		-	-	-	-	-	-	Yes
User settings 1 - 7		Yes	Yes	Yes	Yes	Yes	Yes	Yes	

\*1: Japan only

**(8) Paper exit section**

**a. Exit Capacity**

Exit location	Center	Right side (option)
Exit Capacity	400 sheets (A4/8.5" x 11": 80g/m <sup>3</sup> )	100 sheets (A4/8.5" x 11": 80g/m <sup>3</sup> )



**b. Size of paper which can be discharged**

Paper exit section			Duplex	Main unit center tray		Right exit tray
				Exit tray	Off set	
Paper size	12" x 18" (A3W)		-	-	-	Yes
	11" x 17"		Yes	Yes	Yes	Yes
	8.5" x 14" (216 x 356)		Yes	Yes	Yes	Yes
	8.5" x 13.5" (216 x 343)		Yes	Yes	Yes	Yes
	8.5" x 13.4" (216 x 340)		Yes	Yes	Yes	Yes
	8.5" x 13" (216 x 330)		Yes	Yes	Yes	Yes
	8.5" x 11"		Yes	Yes	Yes	Yes
	8.5" x 11"R		Yes	Yes	Yes	Yes
	7.25" x 10.5"R		-	Yes	Yes	Yes
	5.5" x 8.5"R		Yes	Yes	Yes	Yes
	A3		Yes	Yes	Yes	Yes
	B4		Yes	Yes	Yes	Yes
	A4		Yes	Yes	Yes	Yes
	A4R		Yes	Yes	Yes	Yes
	B5		Yes	Yes	Yes	Yes
	B5R		Yes	Yes	Yes	Yes
	A5R		Yes	Yes	Yes	Yes
	8K		Yes	Yes	Yes	Yes
	16K		Yes	Yes	Yes	Yes
16KR		Yes	Yes	Yes	Yes	
JPC *1		-	Yes	Yes	Yes	
Envelope		-	Yes	-	-	
Custom		Yes	Yes	-	Yes	
Paper type	Thin paper	13-16lb bond (55-59g/m <sup>2</sup> )	-	Yes	Yes	Yes
	Plain paper	16-28lb bond (60-105g/m <sup>2</sup> )	Yes	Yes	Yes	Yes
		Recycled paper	Yes	Yes	Yes	Yes
		Color paper	Yes	Yes	Yes	Yes
		Letter head	Yes	Yes	Yes	Yes
		Pre printed	Yes	Yes	Yes	Yes
		Pre Punched	Yes	Yes	Yes	Yes
	Heavy paper	28lb bond - 110lb index (106-209g/m <sup>2</sup> )	Yes	Yes	Yes	Yes
		110lb index - 140lb index (210-256g/m <sup>2</sup> )	-	Yes	Yes	Yes
	Envelope	75-90g/m <sup>2</sup>	-	Yes	-	-
	OHP Transparency		-	Yes	-	Yes
	Label		-	Yes	-	Yes
	Tab paper		-	Yes	-	-
	Grossy paper		-	Yes	Yes	-
User settings 1 - 7		Yes	Yes	Yes	Yes	

\*1: Japan only

**(9) Operation panel**

Size	10.1 inch
Type	Dot matrix LCD, touch panel
Display dot number	1,024 x 600 dots (WSVGA)
LCD back-light	LED lamp back-light system

**(10) Controller board**

CPU	ARM11: 600MHz ARM9: 400MHz/during 1W energy save mode: 75MHz
PCL accelerator	MPC8535 Power QUICC e500 1.2GHz
Interface	
Ethernet	1port
Interface	10Base-T, 100Base-TX, 1000Base-T
Support Protocol	TCP/IP (IPv4, IPv6), IPX/SPX, NetBEUI, EtherTalk
USB 2.0 (high speed) (host)	2port (Simultaneous use of the front/rear ports is enable.)
USB 2.0 (high speed) (device)	1port
USB-HUB (host)	Internal: 4port • For Front USB Port • For Rear USB Port • For IC card reader • For Keyboard
ACRE expansion I/F	Yes
Serial I/F	1port
Memory	See the section "Memory/Hard disk".
Memory slot	4 slot (2 slot: empty)

**(11) Memory/Hard disk**

SD card	MFP control PWB	Printer control PWB		HDD*1
	SLOT1	SLOT3	SLOT4	
4GB	2GB (STD)	1GB (STD)	1GB (OPT)*2	160GB (STD)

\*1: HDD capacity depends on procurement and sourcing status.

\*2: Need to memory for XPS expansion kit.

Memory area (SD card)	Boot/Program area
	FAX data storage area 1GB

**(12) Warm-up time**

	Main power SW
Warm-up time*1	20sec. or less
Pre heat	Yes
Jam recovery time*2	37sec. or less

\*1: Result may change depending on conditions.

\*2: Conditions: Leave the machine for 60 sec. after door open, standard condition, Polygon stops.

**B. Copy functions**

**(1) First copy time**

Engine	26cpm machine		31cpm(A) machine		36cpm machine	
	Mono-chrome	Color	Mono-chrome	Color	Mono-chrome	Color
Platen	5.9 sec. or less	8.1 sec. or less	5.8 sec. or less	7.9 sec. or less	5.2 sec. or less	6.8 sec. or less
RSPF	9.1 sec. or less	11.6 sec. or less	9.1 sec. or less	11.6 sec. or less	8.1 sec. or less	10.6 sec. or less

**(2) Job Speed**

Engine	26cpm machine		31cpm(A) machine		36cpm machine	
	Mono-chrome	Color	Mono-chrome	Color	Mono-chrome	Color
S to S	26cpm (100%)	26cpm (100%)	31cpm (100%)	31cpm (100%)	36cpm (100%)	36cpm (100%)

**(3) Job Effectiveness**

BLI Standard (RSPF)

Engine	26cpm machine		31cpm(A) machine		36cpm machine	
	Mono-chrome	Color	Mono-chrome	Color	Mono-chrome	Color
S to S	24cpm (92.3%)	24cpm (92.3%)	29 pm (93.5%)	28cpm (90.3%)	33cpm (91.7%)	32cpm (88.9%)
S to D	23cpm (88.5%)	23cpm (88.5%)	27cpm (87.1%)	26cpm (83.9%)	31cpm (86.1%)	30cpm (83.3%)
D to D	23cpm (88.5%)	22cpm (84.6%)	26cpm (83.9%)	25cpm (80.6%)	30cpm (83.3%)	28cpm (77.8%)

\* S to S: 10 pages of A4 / 8.5" x 11" document and 5 copies

\* S to D: 10 pages of A4 / 8.5" x 11" document and 5 copies

\* D to D: 10 pages (20 sides) of A4 / 8.5" x 11" document and 5 copies

**C. Printer function**

**(1) Printer driver supported OS**

	OS	Custom PCL6	Custom PS	PPD	PC-FAX
Windows	2000	CD-ROM	CD-ROM	CD-ROM	CD-ROM
	XP	CD-ROM	CD-ROM	CD-ROM	CD-ROM
	XP (x 64)	CD-ROM	CD-ROM	CD-ROM	CD-ROM
	Server 2003	CD-ROM	CD-ROM	CD-ROM	CD-ROM
	Server 2003 (x 64)	CD-ROM	CD-ROM	CD-ROM	CD-ROM
	Vista	CD-ROM	CD-ROM	CD-ROM	CD-ROM
	Vista (x 64)	CD-ROM	CD-ROM	CD-ROM	CD-ROM
	Server 2008	CD-ROM	CD-ROM	CD-ROM	CD-ROM
	Server 2008 (x 64)	CD-ROM	CD-ROM	CD-ROM	CD-ROM
	Windows 7	CD-ROM	CD-ROM	CD-ROM	CD-ROM
	Windows 7 (x 64)	CD-ROM	CD-ROM	CD-ROM	CD-ROM
Mac	9.0-9.2.2	No	No	Web	No
	X 10.2.8	No	No	Web	No
	X 10.3.9	No	No	Web	No
	X 10.4.11	No	No	CD-ROM	No
	X 10.5-10.5.8	No	No	CD-ROM	Web
	X 10.6-10.6.5	No	No	CD-ROM	Web

## (2) PDL emulation/Font

PDL (Command)		Installed font	Option font
PCL6 compatibility	STD	European outline font = 80 styles Line printer font (BMP) = 1 style	Barcode font = 28 styles
Postscript3 compatibility	OPT	-	European outline font = 136 styles
Scalable font for List Print	STD	Arphic mobile font	-

## D. FAX function

### (1) Transmission method

Transmission time	Less than 3 sec (Super G3) Less than 7 sec (G3 ECM)
Compression/ expansion system	MH, MR, MMR, JBIG (Fixed to ECM for MMR or JBIG.)
Modem speed	33.6kbps → 2.4kbps automatic fallback
Resolution	8 x 3.85 line/mm, 8 x 7.7 line/mm, 8.15.4 line/mm, 16 x 15.4 line/mm (Standard memory is used for transmit/receive.)
Intercommunication	G3/Super G3: Standard (V.34, V.17, V.33, V.29, V.27ter)
Communication line	General telephone line (PSTN), ISDN (When TA is installed.) Private Branch Exchange (PBX)
ECM	Yes

### (2) Number of Support Line

Standard	1 line
Expansion	Not provided

### (3) Transmission Mode

RSPF/OC transmission switching	Yes (Switching during the reading is feasible (When Preview and Job build mode))
-----------------------------------	---

### (4) Image Quality/Image Process

Half tone reproduction	Equivalent to 256 levels (Valid only when monochrome document is scanned.)
Exposure adjustment	Auto / Manual (5 steps)
FAX quality selection	Standard (8 x 3.85 lines/mm (203.2 x 97.8dpi)) Fine (8 x 7.7 lines/mm (203.2 x 195.6dpi)) Super Fine (8 x 15.4 lines/mm (203.2 x 391dpi)) Ultra Fine (16 x 15.4 lines/mm (406.4 x 391dpi)) Half-tone (Combination with normal character is invalid.)

### (5) Record Size

Max. record width	293mm
Record size	(AB series) A3, B4, A4, A4R, B5, B5R, A5R (Inch series) 11 x 17, 8.5 x 13, 8.5 x 14, 8.5 x 11, 8.5 x 11R, 8.5 x 5.5R

\* If the document length exceeds A3 size, it is divided and printed.

\* For printing the list, A5R and 8.5 x 5.5R cannot be used.

### (6) Dial

Manual dialing	To be entered by 10-key, # key, * key
Re-dialing	The previous 50 items (max.) can be saved, and one of them can be selected. One-touch call is available.
One-touch dialing	2000 items including the group dialing items
Group dialing	2000 items including the one-touch dialing items
Program dialing	48 items + preset 1 item
Chain dialing	Max. 64 digits including one-touch dialing, 10-key dialing, and pause.
Dial search	Alphabet order search, User index groups
Quick search	Yes
LDAP search	Yes
Sub address	Yes
Password	Yes
Memory box registration	Yes

\* LDAP: Lightweight Directory Access protocol

### (7) Memory for Transmit/Receive

FAX transmission data	HDD
FAX reception data	SD card

### (8) Function

Transmit function	Calling function	Yes Requires the frequency setting for each destination.
	PBX function	Germany, France only
	Memory transmit	Yes (Definable destinations: 94 destinations)
	On-hook	Yes
	Quick online transmit	Yes
	Direct transmit	Yes
	Manual transmit	Yes
	Auto re-call mode	Yes
	Time indication function	Yes
	Sequential broadcasting function	Yes
	F code interface broadcasting indication function	Yes Only one interface station can be specified.
	F code interface broadcasting function	Yes
	F code confidential send function	Yes
	Polling	Yes Even with another company machine
	Sequential polling function	Yes Even with another company machine
	F-code polling	Yes
	Bulletin board	Yes
	F code bulletin board function	Yes
	Auto reduction transmit	Yes A3 → B4, A3 → A4, B4 → A4
	Rotation transmit	Yes Counterclockwise rotation of 90 degrees
Duplex transmit	Yes	

Transmit function	Document transmit from OC function	Yes	
	Long length original transmit	Only when RSPF is used. Transmission is enable up to 1000mm.	
	Mixed documents function	Only when RSPF is used.	
	Zoom transmit	Yes	
	2 in 1 transmit	Yes	
	Card shot transmit	Only when transmitting from OC	
	Thin paper scan function	Available except for duplex scan	
	Edge erase transmit function	Yes Only for the fixed sizes	
	Job build	Yes	
	Page division transmit	Yes	
	Cover	No	
	Index	No	
	Transmit message adding function	No	
	Receive function	Auto receive	Yes
Manual receive		Yes	
DRD call function		Distinctive Ring Detection North America: Standard, Pattern 1 – 5 Australia/New Zealand/Hong Kong: ON/OFF (TEL/FAX)	
Memory receive		Yes	
Transfer function		Yes Number of registration: 1 item	
Specified receive function		Yes (Number of registration) Rejection numbers: Max.50 items	
Receive data print condition function		Yes	
Receive data staple setting/ Copy number setting		Yes	
Rotation receive		Yes Output by clockwise rotation of 90 degrees	
Divided receive		Yes Divided print is not made in duplex mode.	
Duplex receive		Yes	
F-code confidential receive		Yes	
Special function		Print hold	Yes
		Document Admin	Yes
	Inbound Routing	Yes	
	Sender registration function	Yes	
	Sender print function	Yes	
	On-hook dialing function	Yes	
	Retransmit function	Yes	
	Pause function	Yes Pause time is 1 – 15 sec.	
	Sound volume setting function	Yes	
	Tone pulse select function	Tone, Pulse, Auto (North America/Taiwan) * For the other destinations, set with the soft switch.	
	External phone connection	Yes	
	Memory remaining capacity check function	Yes Only the integral part is displayed.	
	Back up	Yes	
	Registered data read/write function	Yes	
	Report/List	Yes	
	Destination check function	Yes	
	Broadcasting destination display function	Yes	
	Transmit job change function	Yes	
	Save-energy function	Yes	
	Line monitor display function	Yes	

Special function	FAST	Yes Facsimile Automated Service Technology
	Time adjust function	Yes Summer time ON/OFF
	PC-FAX	Yes
	Color mode	No
	Sender registration function	Yes Number of registration: 1 for standard sender name and address. And 18 sender names can be registered.
	Default destination setting	No
	Unauthorized scan prevention function	Yes
	Filing-each-page function	No
	Re-operation function	Yes
	User account function	Yes Max. 200 items additionally to the default
	Counter function	Yes

## E. Image send function

### (1) Mode

FAX	FAX to e-mail/FTP
-----	-------------------

### (2) System environment

Copier memory (Local memory)	Printer memory (System Memory)
1GB (Standard)	512MB (Standard)

### (3) Image send function (Push send from the main unit)

#### a. Support image

Mode	FAX
Compression method	MH, MR, MMR, JBIG

#### b. Image processing

Mode	FAX
Original scanning color	B/W
Halftone reproduction	Equivalent of 256 steps
Density adjustment	Auto + 5 steps
Selection of image quality	Half tone (Black-white only) ON/OFF
Resolution (depends on file format/transmission method)	Standard character (203.2 x 97.8dpi) (half tone not allowed)
	Fine (203.2 x 195.6dpi)
	Super fine (203.2 x 391dpi)
	Ultra fine (406.4 x 391dpi)

### c. Specification of Addresses

Mode	FAX
Address specification	Specification by one-touch/group/direct address entry. Entry from 10-key. (Fax) Selection from LDAP server
Number of One-touch address key registration	Total (number of key): Maximum 2000
Number of Group (1 key) address registration	Number of Group (1 key) address registration: maximum 500 Number of Group key registration: 6000 (Total address number included in /2000 key)
Program	48 items + preset 1 item
Direct entry of addresses	Entry by 10-key, # key
Chain dial	Yes (pause key)
Resend	Call up nearest 50 addresses. *1
Destination confirmation	Yes
Shortcut for address selection (quick key)	Use the 10-key to call up registered numbers of addresses.
Disable direct entry transmission *2	Yes
Disable broadcast transmission	Yes
Disable PC- Fax sending	Yes

\*1: Except for FTP, Desktop, SMB, USB memory, Broadcast.

\*2: When disabled, the address registration is not allowed either.

### d. Specification of Multiple Addresses

Mode	FAX
Broadcast	Yes (500 destinations)
Request of serial transmission	Yes

\* Broadcast transmission is allowed. (Monochrome only)

### e. Transmission function

Mode	FAX	
Memory transmission	94 destinations in all	
On-hook	Yes	
Quick online transmission	Yes	
Direct transmission	Yes (Switching: Memory transmission ↔ Direct transmission)	
Automatically-reduced transmission	Yes	
Rotated transmission	Yes	
Scaled transmission	Yes Enlargement/reduction is allowed only from a fixed size to another. Reduction may be done on the receiver side with Fax/Internet Fax sending.	
Recall mode	Error	Yes
	Busy	Yes
	Number/time to be set up through system setup	
Long original transmission	Yes Maximum of 1000mm (single side only/black-white 2 values only)	
Confidential transmission (Sharp mode)	No	
Relay broadcast transmission (Sharp mode)	No	
Large capacity original mode	Yes	
Scanning of thin paper	Yes	
Mixed originals feeder	Yes (Random + MIX)	
Default date sender transmission	Yes (ON only)	
Preview	No	
Side erase	Yes	

### f. Reception function

Mode	FAX
Automatic reception	Yes
Manual reception	No Switching from manual reception to automatic reception. (Allowed only for France and Japan)
Memory reception	Yes
Fixed size reduced reception	Yes
Specified size scaled reception	No
Rotated reception	Yes
Setting of received data print condition	Equal size print (partition not allowed) Equal size print (partition allowed) Equal or reduced size print
2-sided reception	Condition setting through system setting
2-in-1 reception	No
Automatic reduction setting upon receiving A3	Yes
Automatic reduction setting upon receiving letter	Yes (Other than North America and Inch destinations)
Reception from a specific number not allowed, or allowed. (Allow/Reject)	Specified numbers only (50 numbers /20 digits)
External phone connection remote	Yes
Confidential reception (Sharp mode)	No
Received data bypass output	Yes
Index printing	No
Transfer function upon disabling of output.	Yes (1 receiver (of transfer) registration)
Internet Fax/Fax to e-mail (Transfer of Internet Fax/Fax reception data to e-mail, inbound routing)	Yes
Exit tray setting	Yes
Insertion of job separator sheet	No
Staple function of received data	Yes
Auto wake up print	Yes
Received data print hold *1	Yes
Color toner print when black toner runs out.	No

\*1: This function saves all received data in memory and starts output after password entry. (Confidential reception is excluded.)  
Setting only on the receiver side.

### g. Report/list function

Mode	FAX
Image sending activity report	Yes Time-specified output Output with memory full * Maximum of 200 times including both transmission and reception
Transaction report	Yes
Address/phone number table	Yes
Group table	Yes
Program table	Yes
Memory box table (F code)	Yes
Communication original contents print	Always print/Upon error/no print
List of allowed or rejected reception numbers	Yes
Table of control record for each account	No

## h. Other Functions

Mode	FAX
Time specification	Yes
Polling reception	Yes
Bulletin board transmission	Yes Up to 100 registrations allowed with bulletin board, confidential and relay broadcast all combined. (Free area: 1 registration) Setting of the number of transmission: 1/no limit.
Cover sheet function	No
Transmission message	No
Sender print	Yes
Sender selection	Yes
Page number print	Yes
Date print	Yes (Date can be expressed alternatively)
Polling protection function	Yes
Page partition transmission	Yes
Page connection	No
Confidential (receiver unit)	Yes (F code method)
Relay broadcast instructions	Yes (F code method)
Fax to e-mail (F code) *1	Yes
Edge erase	Yes
Center erase	Yes
2 in 1	Yes
Card shot	Yes (Equivalent or enlargement up to the paper width. The maximum enlargement is not allowed to exceed 400%)
Forward data transmission/reception (Document Admin)	Yes Data transmission by PC-Fax/PC-Internet Fax is allowed, too.

\*1: This function means that e-mail address setting on F code relay broadcast allowed.

## i. Transmission Method

Mode	FAX
Transmission time	2 seconds level (super G3/JBIG), 6 seconds level (G3 ECM)
Modem speed	Automatic fall-back: 33.6kbps → 2.4kbps
Intercommunication	Super G3/G3
Communication line	General membership telephone line (PSTN), independent business line (PBX), F net. (R-key for PBX setting: Germany/France)
ECM	Yes

## j. Record Size

Mode	FAX
Maximum record width	293mm
Record size	A3 – A5/11 x 17 – 5.5 x 8.5

## k. F code communication

Mode	FAX
Sub-address	Yes (20 digits)
Password	Yes (20 digits)

## l. Registration-related settings

Mode	FAX
One-touch/group *1 E-mail FTP Desktop SMB FAX	2000 destinations Use of LDAP allowed Up to 500 registered addresses for each group dial. Registered name in 18 full-size character (36 half-size characters) One-touch dial receiver number registration: within 64 digits for receiver number + sub-address + passcode (including "/").
Address book registration from Resend screen	Yes
Program	Registration of addresses (groups), settings (density, image quality) and special functions in one set is allowed. (48 + preset 1)
Number of memory boxes	Registration of bulletin board/confidential/relay broadcast is allowed up to 100. Registration name: 18 characters
Number of sender registration	1 (default) with 40 characters
Number of sender selection registration	Total: 18 registrations (40 characters) (Sender selection: In addition to default, 18 registrations allowed)
Registration of polling approval number	10 numbers/20 digits
Registration of Fax system number (Sharp mode)	No
Registration of Fax polling approval ID number (Sharp mode)	No
Fax relay ID registration (Sharp mode)	No
Quick key (short cut registration) *2	Yes (001 – 2000)
Import/export of address book	Yes (By storage backup)
Black list (for France)	No

\*1: Since scan/Internet Fax/Fax uses the common address book, the number of addresses allowed for registration is the sum total of all modes.

\*2: Quick key is the function to select an address based on the registered number of each address within the book for address selection. Users should be able to select a quick key number.

## m. Telephone functions

Mode	FAX
On-hook function	Yes
Hold	No
Setting of pause time	Yes (1 – 15 seconds)
Telephone transmission during power outage	No (External telephone transmission allowed)
Tone pulse switching	Tone, Pulse, Auto (North America/Taiwan) * For the other destinations, set with the soft switch.

## n. Sound settings

Mode	Item	FAX
On-hook sound	Sound volume setting	1 - 9
Sound volume for calling	Sound volume setting	1 - 9, No
Line monitor sound	Sound volume setting	1 - 9, No
Reception sound	Sound volume setting	1 - 9, No
Transmission success sound	Sound volume setting	1 - 9, No
Transmission and reception error sound	Sound volume setting	1 - 9, No
Sound setting for end of original reading (image send)	Sound volume setting	Large/middle/small/no sound

**o. Others**

Mode	FAX
PC-FAX	Yes
FAST	Yes (SEC only)
Network FAST	No
Distinctive ring detection	Setting for each destination

**F. Power consumption**

The full configuration can be operated with the rated power source.

Maximum rated power Consumption*1	100 V	200 V
		1.44 kW
Energy consumption rate	Not applicable	
TEC value (Measured result)	26cpm machine: 5.3 kWh 31cpm(A) machine: 5.8 kWh 36cpm machine: 6.1 kWh	26cpm machine: 2.0 kWh 31cpm(A) machine: 2.3 kWh 36cpm machine: 3.0 kWh
TEC value (Standard) Tier2	26cpm machine: 6.10 kWh (0.1 kwh*26 + 3.5 kwh) 31cpm(A) machine: 7.85 kWh (0.35 kwh*31 - 3.0 kwh) 36cpm machine: 9.60 kWh (0.35 kwh*36 - 3.0 kwh)	
Network/Fax waiting power consumption	1 W Condition: • No USB port • The network protocol is TCP/IP only. • The Ethernet connection partner supports 10M/100MBASE or 10M/100M/1000MBASE and auto negotiation setting. * Exclude the case of use Fax and Network at once) * North America Default : Wake up mode	—
Moving time to pre-heat mode	1 minutes (default)	
Recovery time from pre-heat mode	10 sec.	
Moving time to sleep mode	1 minutes (default)/11 minutes (Europe) * Printer mode: 10sec.(default)	
Recovery time from sleep mode	20 sec.	

\*1: Power switch ON, dehumidity heater OFF

**G. Dimensions and Weight**

	26cpm/31cpm(A) machine	36cpm machine
Outer dimension (Included operation panel)	W583 x D658 x H834mm	W608 x D680 x H834mm
Footprint	W583 x 658mm (Excluded right exit tray) W831 x 658mm (Included right exit tray)	W608 x 680mm (Excluded right exit tray) W856 x 681mm (Included right exit tray)
Dimension occupied by the machine (When the bypass tray is extended)	W964 x D658mm (When the right paper exit tray is extended.)	W988 x D680mm (When the right paper exit tray is extended.)
Weight	73.1kg (North America)	75.9kg (North America)
Main Unit (including photoreceptor / not including consumables)	73.7kg (Europe)	76.5kg (Europe)

**H. Ambient conditions**

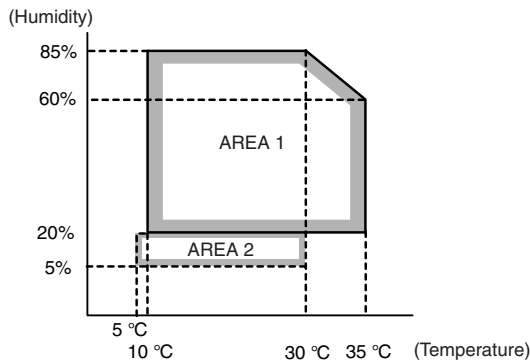

#### 4. List of parts included in the package of developer

Country	Model		
	MX-2310F/U MX-3111F/U	MX-1810U MX-2010U	MX-2610FN/N MX-3110FN/N MX-3610FN/N
Japan	Yes	-	Yes
North America/ South America (Mexico/120v except Brazil and Argentina)	Yes	-	Yes
Europe/UK	Yes	Yes	Yes
Australia/New Zealand	No	No	No
Philippines	No	No	No
Lebanon/Pakistan	No	No	No
Thailand	Yes	Yes	No
Egypt/Jordan	No	No	No
Tunisia/Morocco	No	No	No
Singapore/Malaysia/ Vietnam	Yes	Yes	No
Israel	No	No	No
India	Yes	Yes	No
Hong Kong	Yes	Yes	No
Brazil	No	No	No
Yemen/Saudi Arabia/ Barren/Kuwait/ UAE/Oman/Qatar	No	No	No
Taiwan	No	No	No

Yes: Developer is included with shipment.

No: Developer is not included with shipment.



# [15] TOOL LIST

Name	Part code	Note
Color copy test chart	UKOG-0326FCZZ/UKOG-0326FC11	
SIT chart	UKOG-0280FCZZ/UKOG-0280FCZ1	
Gray test chart	UKOG-0162FCZZ	
Color image density sensor calibration jig	UKOG-0318FCZZ	
Kynar powder	UKOG-0123FCZZ	For transfer belt
Grease (HANARL FL-955R)	UKOG-0299FCZZ	
Conduction grease (FLOIL GE-676)	UKOG-0012QSZZ	Other shaft
Grease (FLOIL G-313S)	UKOG-0307FCZZ	
Grease (JFE552)	UKOG-0235FCZZ	
Stearic acid powder	UKOG-0312FCZZ	OPC drum
Grease (FLOIL GP-501MR)	UKOG-0013QSZZ	RSPF paper feed roller shaft
Grease (MOLYKOTE X5-6020)	UKOG-0158FCZZ	
Grease (MOLYKOTE BR-2 Plus)	UKOG-0097FCZZ	

# LEAD-FREE SOLDER

The PWB's of this model employs lead-free solder. The "LF" marks indicated on the PWB's and the Service Manual mean "Lead-Free" solder. The alphabet following the LF mark shows the kind of lead-free solder.

**Example:**

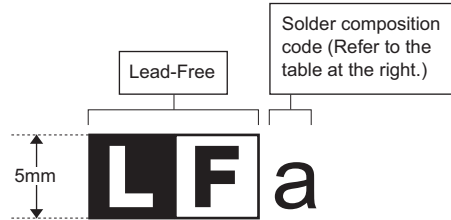

**<Solder composition code of lead-free solder>**

Solder composition	Solder composition code
Sn-Ag-Cu	a
Sn-Ag-Bi Sn-Ag-Bi-Cu	b
Sn-Zn-Bi	z
Sn-In-Ag-Bi	i
Sn-Cu-Ni	n
Sn-Ag-Sb	s
Bi-Sn-Ag-P Bi-Sn-Ag	p

**(1) NOTE FOR THE USE OF LEAD-FREE SOLDER THREAD**

When repairing a lead-free solder PWB, use lead-free solder thread.

Never use conventional lead solder thread, which may cause a breakdown or an accident.

Since the melting-point of lead-free solder thread is about 40°C higher than that of conventional lead solder thread, the use of the exclusive-use soldering iron is recommended.

**(2) NOTE FOR SOLDERING WORK**

Since the melting-point of lead-free solder is about 220°C, which is about 40°C higher than that of conventional lead solder, and its soldering capacity is inferior to conventional one, it is apt to keep the soldering iron in contact with the PWB for longer time. This may cause land separation or may exceed the heat-resistive temperature of components. Use enough care to separate the soldering iron from the PWB when completion of soldering is confirmed.

Since lead-free solder includes a greater quantity of tin, the iron tip may corrode easily. Turn ON/OFF the soldering iron power frequently.

If different-kind solder remains on the soldering iron tip, it is melted together with lead-free solder. To avoid this, clean the soldering iron tip after completion of soldering work.

If the soldering iron tip is discolored black during soldering work, clean and file the tip with steel wool or a fine filer.

### CAUTION FOR BATTERY REPLACEMENT

(Danish) ADVARSEL !  
Lithiumbatteri – Eksplosionsfare ved fejlagtig håndtering.  
Udskiftning må kun ske med batteri  
af samme fabrikat og type.  
Levér det brugte batteri tilbage til leverandoren.

(English) Caution !  
Danger of explosion if battery is incorrectly replaced.  
Replace only with the same or equivalent type  
recommended by the manufacturer.

Dispose of used batteries according to manufacturer's instructions.

(Finnish) VAROITUS  
Paristo voi räjähtää, jos se on virheellisesti asennettu.  
Vaihda paristo ainoastaan laitevalmistajan suosittelemaan  
tyyppiin. Hävitä käytetty paristo valmistajan ohjeiden  
mukaisesti.

(French) ATTENTION  
Il y a danger d'explosion s' il y a remplacement incorrect  
de la batterie. Remplacer uniquement avec une batterie du  
même type ou d'un type équivalent recommandé par  
le constructeur.

Mettre au rebut les batteries usagées conformément aux  
instructions du fabricant.

(Swedish) VARNING  
Explosionsfara vid felaktigt batteribyte.  
Använd samma batterityp eller en ekvivalent  
typ som rekommenderas av apparattillverkaren.  
Kassera använt batteri enligt fabrikantens  
instruktion.

(German) Achtung  
Explosionsgefahr bei Verwendung inkorrekt er Batterien.  
Als Ersatzbatterien dürfen nur Batterien vom gleichen Typ oder  
vom Hersteller empfohlene Batterien verwendet werden.  
Entsorgung der gebrauchten Batterien nur nach den vom  
Hersteller angegebenen Anweisungen.

### CAUTION FOR BATTERY DISPOSAL

(For USA, CANADA)

#### "BATTERY DISPOSAL"

THIS PRODUCT CONTAINS A LITHIUM PRIMARY  
(MANGANESE DIOXIDE) MEMORY BACK-UP BATTERY  
THAT MUST BE DISPOSED OF PROPERLY. REMOVE THE  
BATTERY FROM THE PRODUCT AND CONTACT YOUR  
LOCAL ENVIRONMENTAL AGENCIES FOR INFORMATION  
ON RECYCLING AND DISPOSAL OPTIONS.

"TRAITEMENT DES PILES USAGÉES"  
CE PRODUIT CONTIENT UNE PILE DE SAUVEGARDE DE  
MÉMOIRE LITHIUM PRIMAIRE (DIOXYDE DE MANGANÈSE)  
QUI DOIT ÊTRE TRAITÉE CORRECTEMENT. ENLEVEZ LA  
PILE DU PRODUIT ET PRENEZ CONTACT AVEC VOTRE  
AGENCE ENVIRONNEMENTALE LOCALE POUR DES  
INFORMATIONS SUR LES MÉTHODES DE RECYCLAGE ET  
DE TRAITEMENT.

# SHARP

**COPYRIGHT © 2011 BY SHARP CORPORATION**

All rights reserved.

Produced in Japan for electronic Distribution

No part of this publication may be reproduced,  
stored in a retrieval system, or transmitted,  
in any form or by any means,

electronic; mechanical; photocopying; recording or otherwise  
without prior written permission of the publisher.

## **Trademark acknowledgements**

- Microsoft®, Windows®, Windows® 98, Windows® Me, Windows NT® 4.0, Windows® 2000, Windows® XP, Windows® Vista, Windows® 7, Windows® Server 2003, Windows® Server 2008 and Internet Explorer® are registered trademarks or trademarks of Microsoft Corporation in the U.S.A. and other countries.
- PostScript is a registered trademark of Adobe Systems Incorporated.
- Macintosh, Mac OS, AppleTalk, EtherTalk, Laser Writer, and Safari are registered trademarks or trademarks of Apple Computer, Inc.
- IBM, PC/AT, and Power PC are trademarks of International Business Machines Corporation.
- Acrobat® Reader Copyright® 1987- 2002 Adobe Systems Incorporated. All rights reserved. Adobe, the Adobe logo, Acrobat, and the Acrobat logo are trademarks of Adobe Systems Incorporated.
- PCL is a registered trademark of the Hewlett-Packard Company.
- Sharpdesk is a trademark of Sharp Corporation.
- All other trademarks and copyrights are the property of their respective owners.

**SHARP CORPORATION**  
**Document Solutions Group**  
**CS Promotion Center**

**Yamatokoriyama, Nara 639-1186, Japan**

2011 June Produced in Japan for electronic Distribution