

BARCODE LABEL SCALE

SALES OPERATION MANUAL

Pinnacle Technology Corp.

CONTENT

1	SUMMARIZATION.....	1
2	SPECIFICATION.....	2
3	ACCESSORIES.....	2
4	DIMENSION.....	3
5	APPEARANCE.....	4
6	INSTALLATION.....	6
6.1	Install display pole.....	6
6.2	Hotkey sheet installation.....	7
6.3	Paper Installation.....	8
6.3.1	Label Paper Installation.....	8
6.3.2	Receipt Paper Installation.....	10
6.3.3	Linerless Paper Installation.....	12
6.4	Printer Replacement.....	14
7	KEYBOARD LAYOUT.....	16
8	POWER ON/OFF.....	16
9	SALES OPERATION.....	17
9.1	Calculate by Weight.....	17
9.2	Tare Operation.....	18
9.3	Calculate by Piece.....	20
9.4	Discount.....	20
9.5	Name Input Function.....	21
9.6	Change Price.....	21
9.6.1	Date.....	21
9.6.2	Permanently Change Price.....	22
9.6.3	Temporarily Change Price.....	22
10	General Using Key.....	24
11	SOME SIMPLE OPERATION.....	25
11.1	Copy price label.....	25
11.2	Print receipt.....	25
11.3	Normal Package.....	26
11.4	Package by Fixed weight.....	26
11.5	Package by Fixed Price.....	26
11.6	Gift Baskets Function.....	27
11.7	Traceability Function.....	28
12	FUNCTION SET.....	28
12.1	PLU Set.....	28
12.2	System Set.....	29
12.2.1	Edit Menu.....	29
12.2.2	System set.....	36
12.2.3	Report.....	38
12.3	Function Lock.....	39
12.4	Lock Scale.....	39
13	COMMUNICATION SETUP.....	40
13.1	Wired Ethernet Setup.....	40
13.2	Wireless Ethernet Setup.....	41
13.3	Making procedure of connector.....	42
14	Troubleshooting.....	43
15	APPENDIX.....	46
15.1	Appendix 1: Barcode Coding List.....	46

1 SUMMARIZATION

◆ Unique and powerful network

- 1) Apply Ethernet technology, greatly improve data transmission speed.
- 2) Unique network testing, quickly test network communication.

◆ Simple and easy to operate

- 1) You can use single key to sell PLU quickly. Clerk can operate this scale without training.
- 2) This scale has 112 direct keys (224 hotkeys can be set) and can set hotkeys for most of the common goods.

◆ Advanced function and endurance

- 1) Firmware program can be updated through PC in order to keep advanced and up to date.
- 2) Flash Rom protection function assures the security of program and source.
- 3) Keyboard can be cleaned. It resists dirty with great validity.
- 4) Printer is designed elaborately and not easily subject to paper jam.
- 5) Barcode rotation can prolong the life of printer head. Printer core can be adjusted according to label paper.
- 6) Printer can load 1000 pieces of label paper while other printer can only load 800 pieces of label paper.
- 7) There are several package methods (fixed weight, and fixed price). Barcode printer is specially designed.
- 8) Piece together function, which can gather several kinds of commodity as required, such as fruit basket.
- 9) 12000 pieces of PLU can meet all kinds of demand.
- 10) Every piece of PLU can be set to use multiple labels.
- 11) Every piece of PLU can use single barcode format, which resolves the coding problems during selling.
- 12) Every piece of PLU can use single metric unit.
- 13) Numeric unit can be defined by user such as block, package and entries.
- 14) Sufficient PLU message includes barcode format, live commodity Code and package type and so on.
- 15) Label can be printed in rotated position.
- 16) Support 8 codes, Ean-13 code, and 18 codes and resolve the coding problem of live commodity.
- 17) Special barcode type for the convenience of live commodity lot management.
- 18) Support print trace code.

◆ Convenient, flexible and powerful software support

- 1) What you see in label designing is what you get. Label size can be selected. Volume of smallest area can be created according to user. Thus we can decrease cost greatly.
- 2) International design and supporting worldwide language make it unnecessary to add any accessory.
- 3) We can adjust the popular commodity at any time and improve the foregrounding working efficiency greatly.
- 4) Downloading data can be executed in scheduled time.
- 5) Background discounts fixedly.
- 6) Discount in different period of time. Ten discount modes can be defined and each mode has five periods of time using different discount rate.
- 7) It supports broadcast downloading.
- 8) With the function of FTP and TCP/IP. The software supports Unix system and Internet.
- 9) We can set POS program parameters on PC.
- 10) Its management is separated into machine, commodity, and hotkey, which make usage of the scale optimum.

- 11) We can edit and print keyboard sheet quickly with this software.
- 12) Locking the POS function key can control its operation such as locking discount key and PLU edit key. Also it offers function to unlock password.
- 13) It is managed by multi-user and records login information automatically in order to supervision.
- 14) It offers dynamic link library for the convenience of user's second development.

2 SPECIFICATION

Model	LS2RX	LS2CX	LS2NX
Display screen	32*264 LCD with backlight	48*112 LCD with backlight	65*132 LCD with backlight
Weighing range	6kg/15kg	15kg	15kg/30kg
Verification scale interval	2g/5g	5g	5g/10g
Tare (Max.)	-5.998kg	-5.995kg	-14.995kg
Internal resolution	1/30, 000		
Keyboard	140 keys (28 function keys, 112*2 PLU hot keys) support quickly edit and download PLU data from PC		
Valid printing width	56mm		
Paper entry width	61.5±0.5mm		
Paper roll diameter	Φ90mm MAX		
Print speed	120mm/s		
PLU programming data	LF code, trace code, PLU name, article number, Unit price, price unit, Preservation days, tare, barcode, department, package weight, package type (Normal, fixed weight, fixed price, both fixed), message 1, message 2, label type, discount hotkey, additional text		
Label format	2/5 interleaved, Code128, EAN13 etc. Logo, uppercase and lowercase letters Self-configured label composing & size, adjustable label length ranging from 30~109mm Advanced label format: various barcode, PLU name, additional information etc.		
Data storage	RAM: 2G, Memory 32 label types 12000 PLU, 12000 messages		
Optional function	WIFI802.11g, linerless label printing		
Interface	Ethernet, RS232		
Power supply	AC 100~240V 50~60Hz		
Working temperature	0°C~40°C		
Dimension	387*433*550mm	380*432*493mm	380*385*174.5mm
Weight (include package)	9.2kg	8.7kg	8.1kg

3 ACCESSORIES

- Main unit
- Display box
- Disk
- Scale platter
- Product warranty manual
- User manual
- Fuse 1A
- Blank hotkey sheet

4 DIMENSION

LS2R:

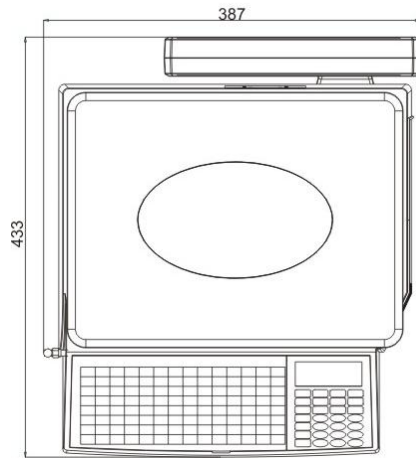
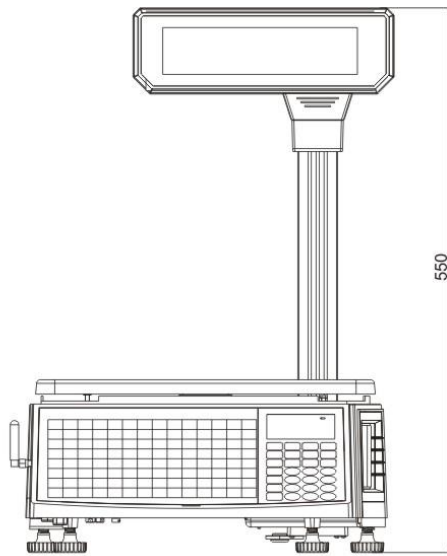

LS2C:

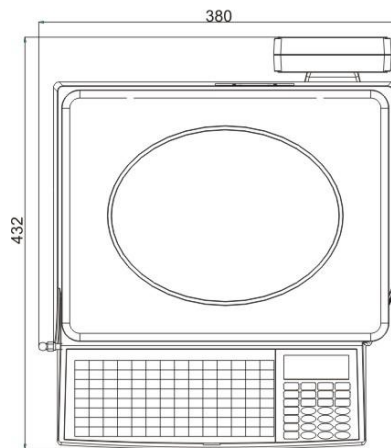
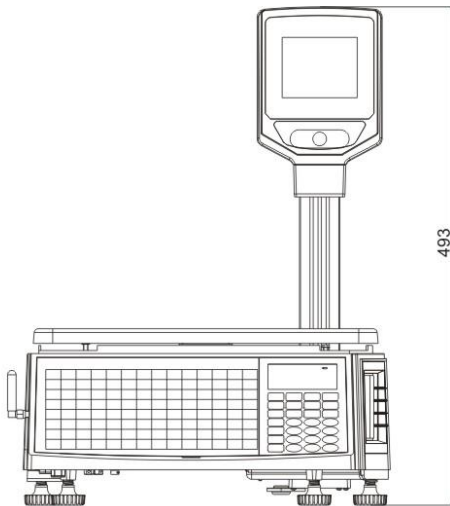

LS2N:

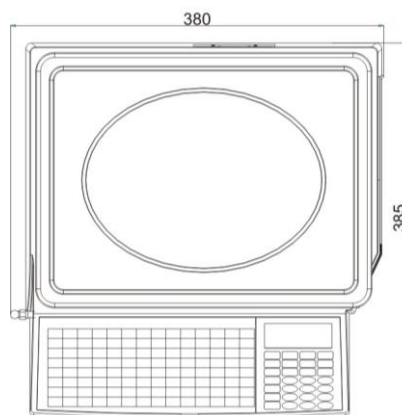
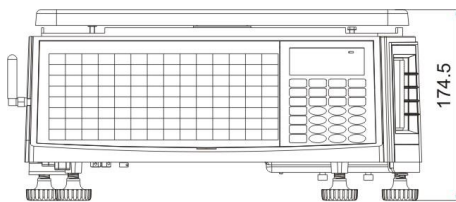

5 APPEARANCE

LS2R:

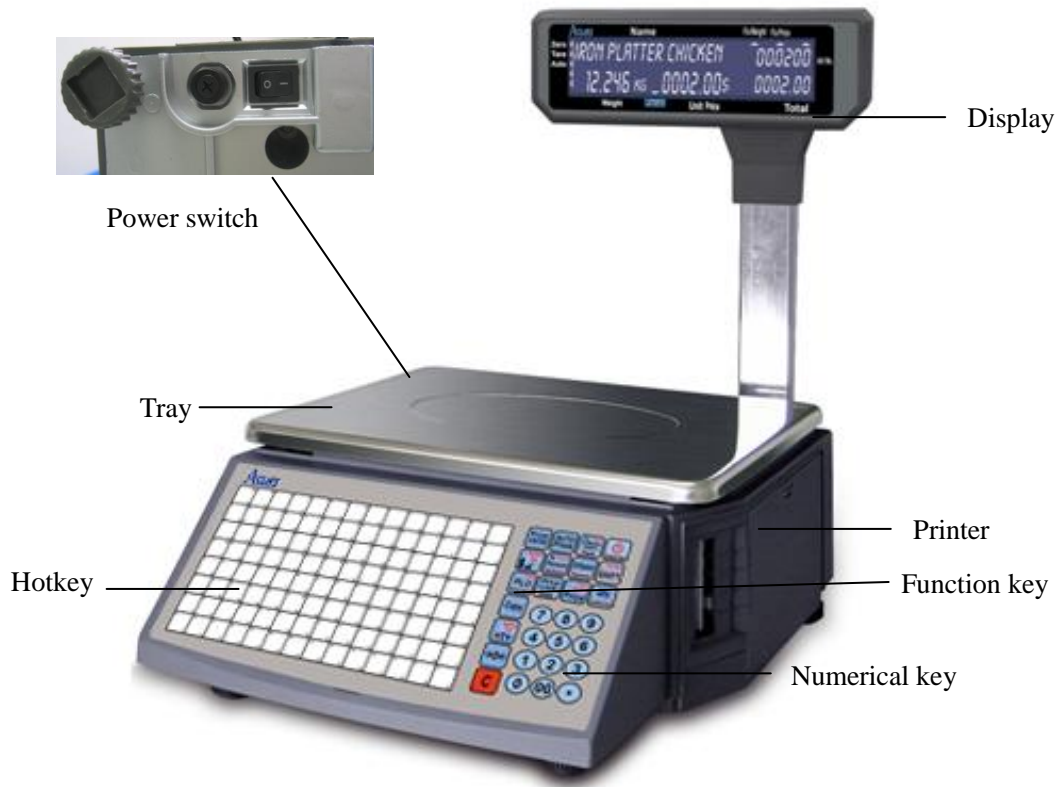

LS2C

:

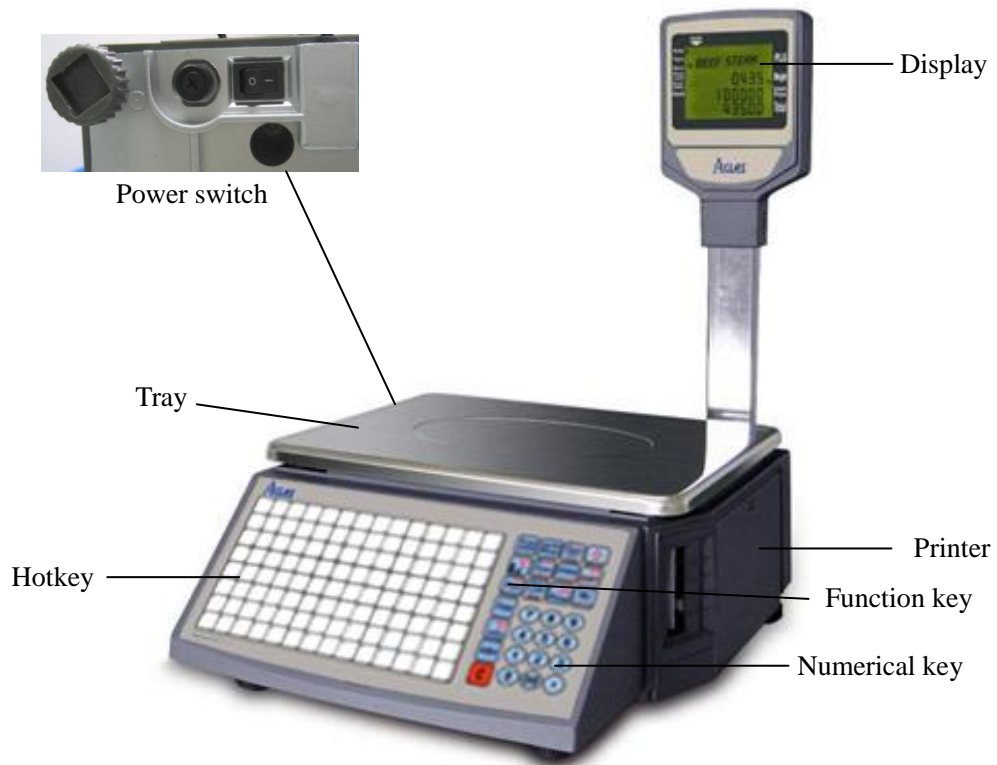

LS2N

:

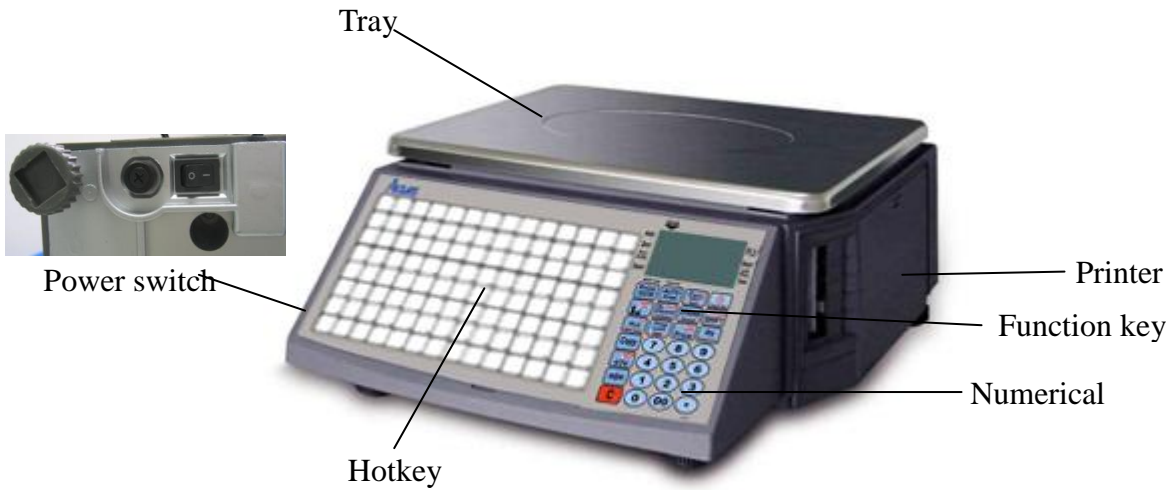

Circumvolve the 4 feet to adjust the level of scale, and make the air bladder into the circle.

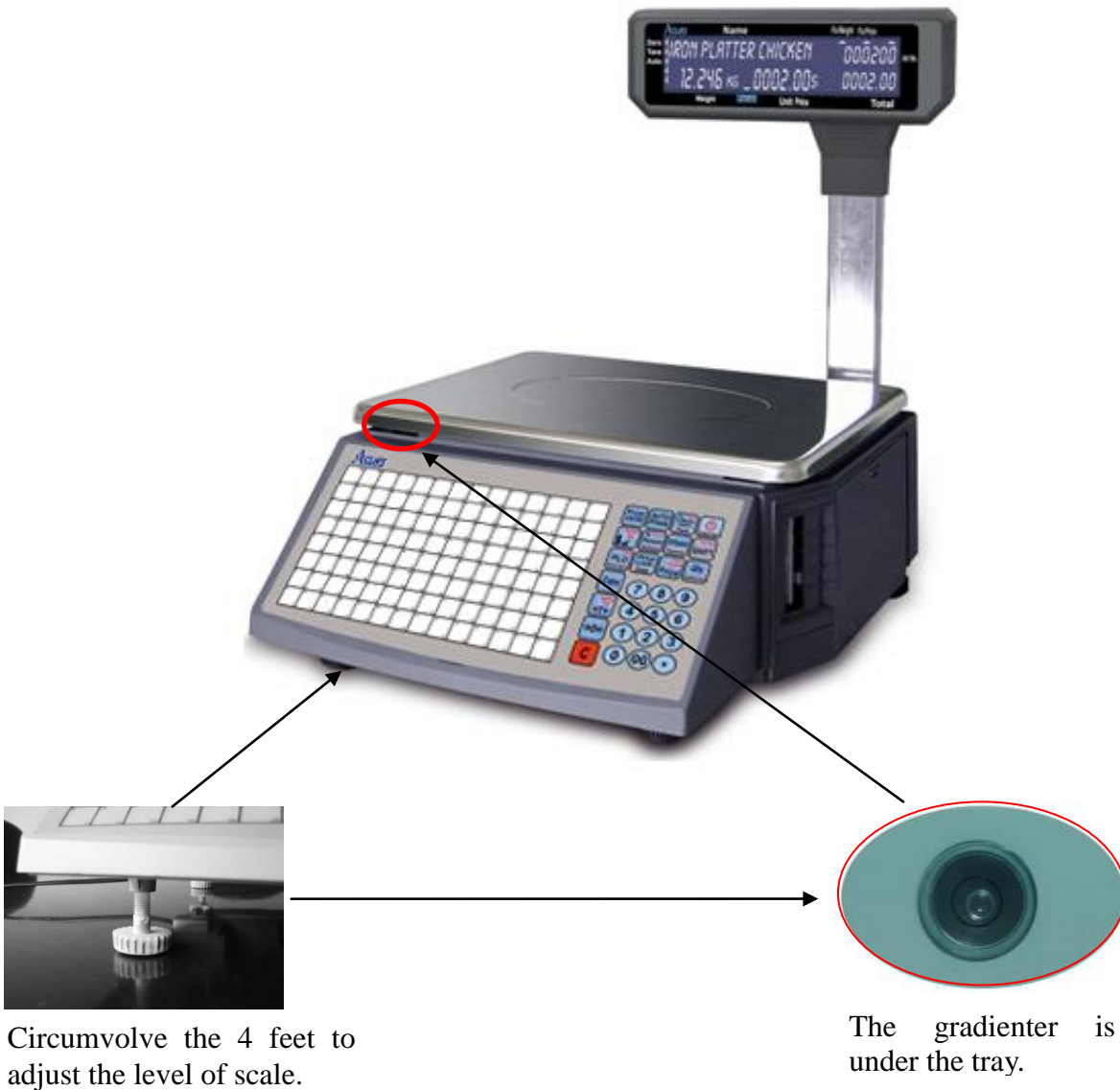

6 INSTALLATION

6.1 Install display pole

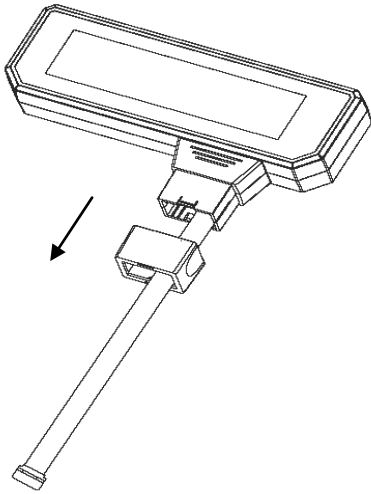

1. Take out the fix set

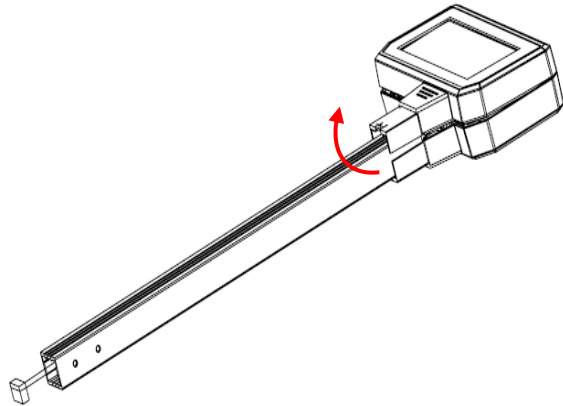

2. Open the LCD cover $3^{\circ} \sim 5^{\circ}$, and Mount the display pole.

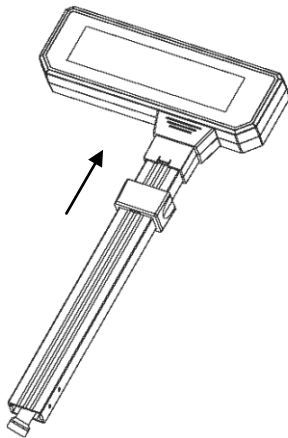

3. Cover the LCD, then put on fix set like the picture shows.

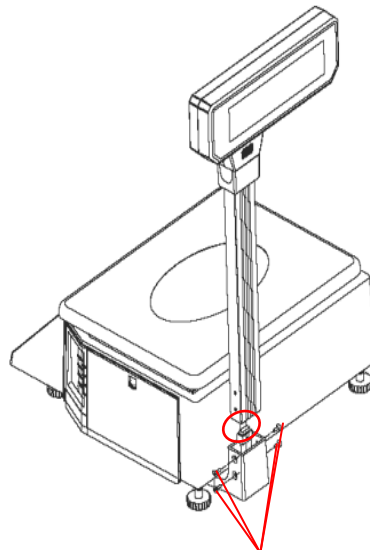

4. Put on fix set .Connect the line, and fix the 4 screws.

6.2 Hotkey sheet installation

Note: Please refer to “PC software management/Hotkey” in attached CD.

Cut the hotkey sheet down and insert the hotkey sheet into the keyboard. Please take below pictures for your references:

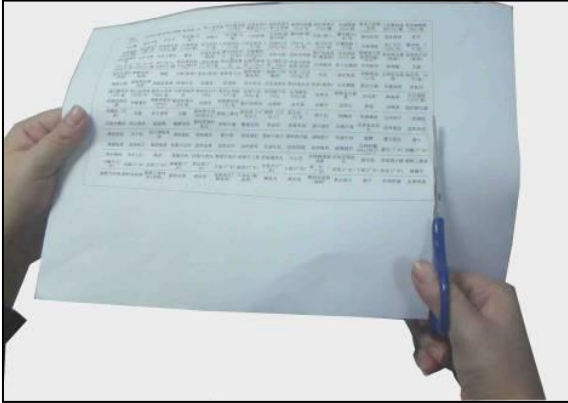

→ Cut the hotkey sheet down.

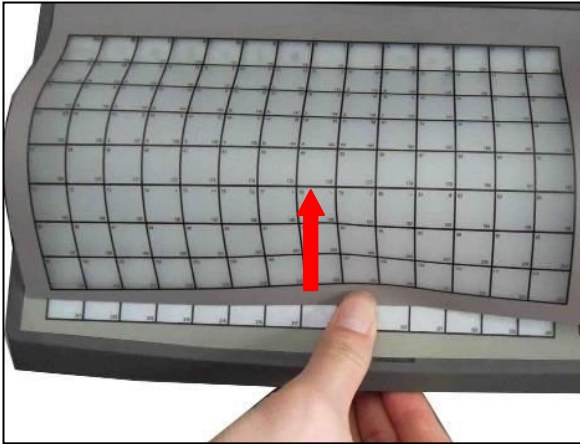
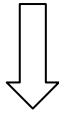

→ Push up the hotkey pad from bottom according to the arrow head.



→ Insert the hotkey sheet into the hotkey pad.

6.3 Paper Installation

6.3.1 Label Paper Installation

Notice: please take the conveying protection bolt down, when you load the paper for the first time.

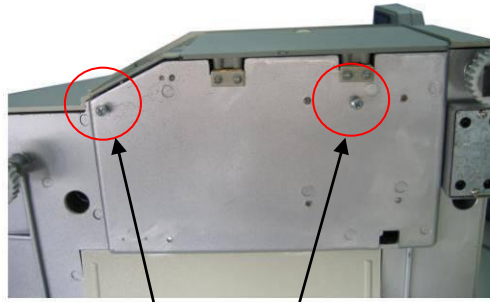

Conveying protection bolt



(1) Open the side cover

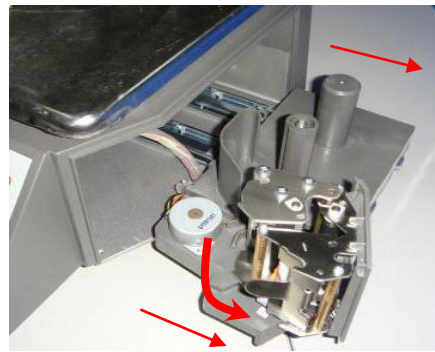

(2) Take out the printer, and open the turnable printing assembly



(3) Rip off the first several labels.

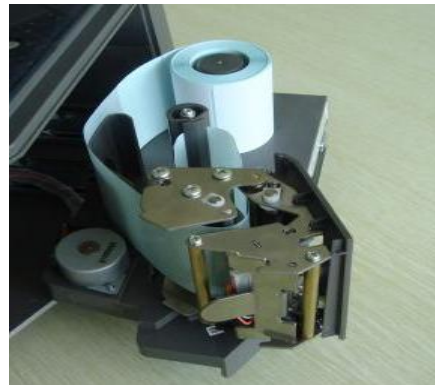

(4) Insert the release paper to the rewriter

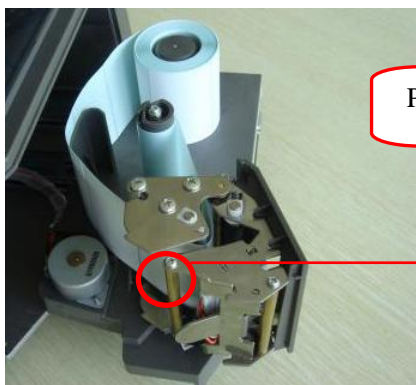

Paper-fixing-block



(5) Roll the release paper in the rewriter axis, and adjust the paper-fixing-block to fix the roll paper.



(6) Close the turnable printing assembly.



(7) Close the side cover

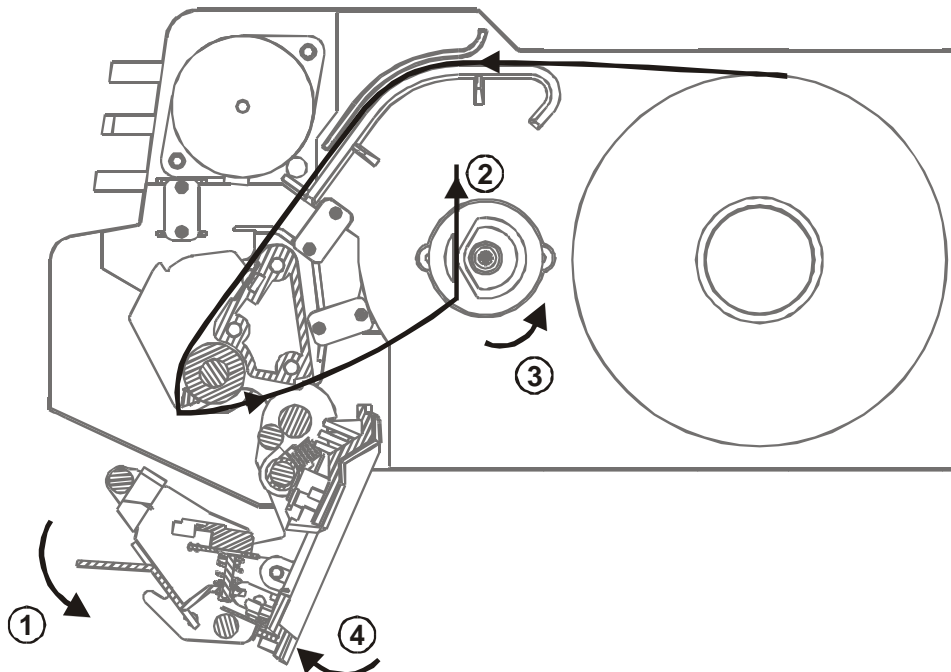

1. Turn the bar outwards, open the turnable printing assembly in the direction shown as the arrowhead ①
2. Please rip off the first several labels, load paper in the direction shown as the arrowhead ②, roll the release paper in the rewriter axis as the direction of arrowhead ③ shows.
3. Push the turnable printing assembly to the right position in the direction shown as the arrowhead ④.
4. When every five-paper roll is used up, or the labels print unclearly, please clean the printing head by using cotton dipping cleaning oil or alcohol.

➤ Label Paper

We have two types of label paper: no-gap paper and gap paper

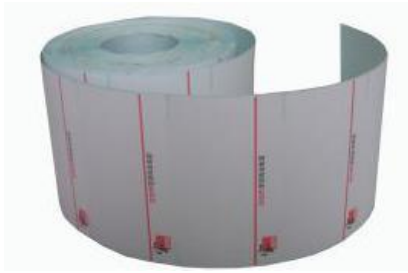

No-gap paper

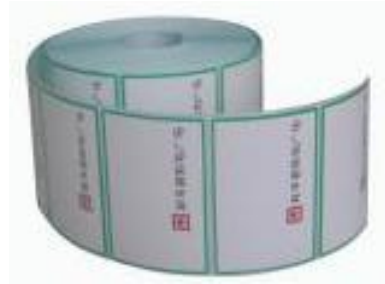

Gap paper (2mm)

The label paper we produced is very suitable for label scale. It is a kind of environment protecting material has suitable thickness, high sensitivity and low price. We can produce any kind of specification label paper to match your request. Order easily, dial 86-592-5710087 or log on our company website www.aclas.tw

6.3.2 Receipt Paper Installation

1. Install the receipt paper-cutter.

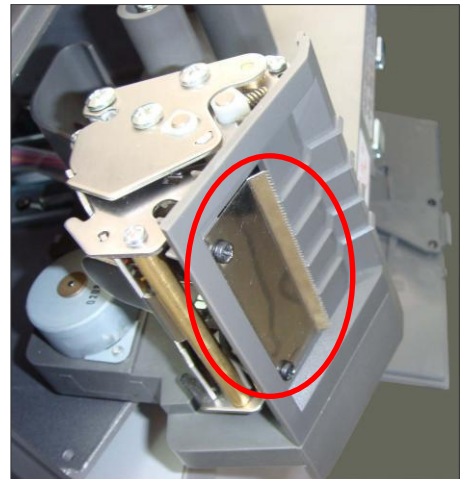

2. Open the turnable printing assembly.

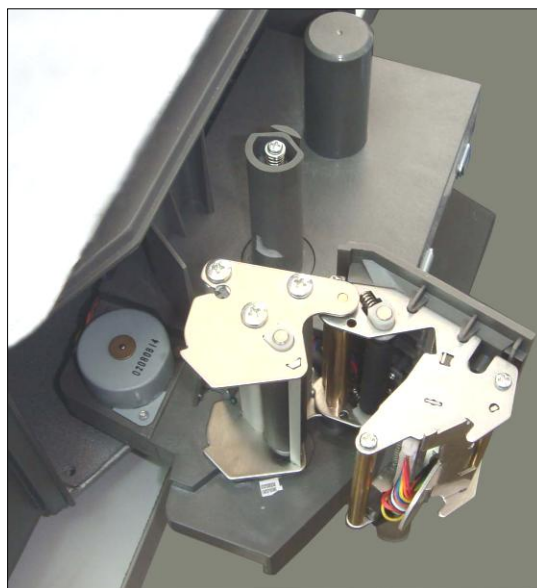

3. Load the paper like the map shows (directly lead the thermal paper to the paper outlet).

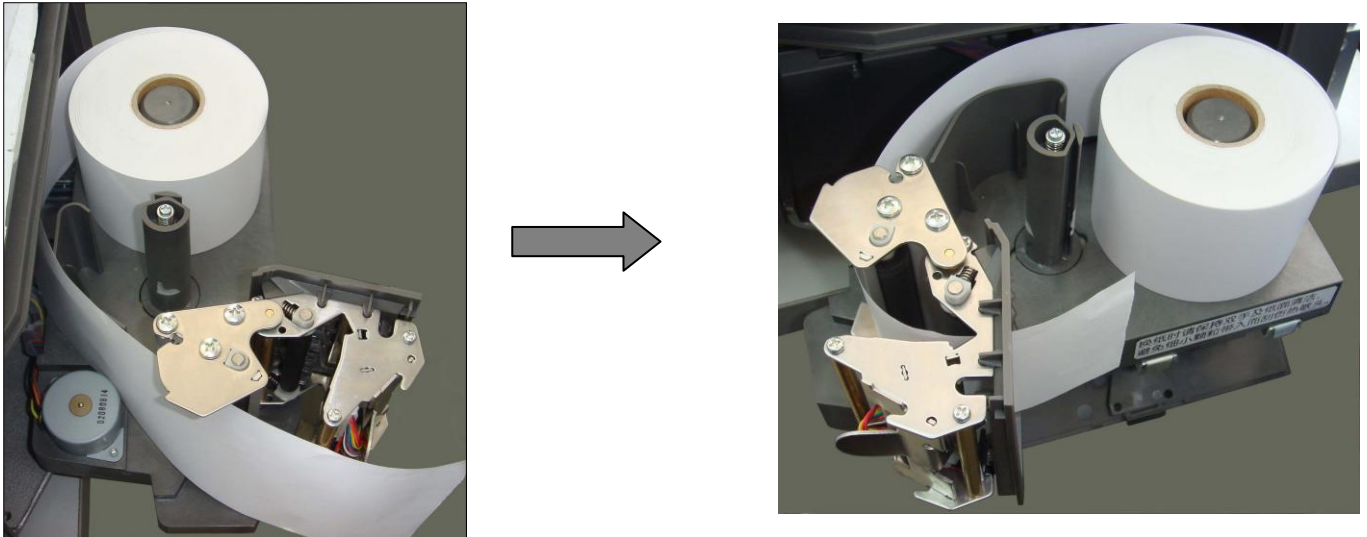

4. Pay attention to adjust the paper-fixing-block until the paper roll is fixed.

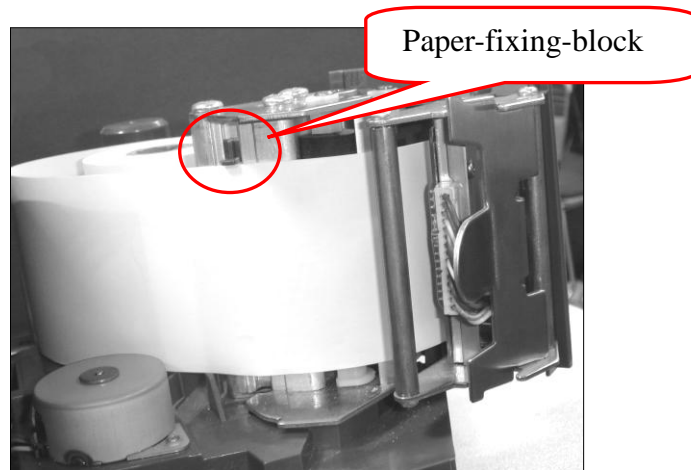

5. Close the turnable printing assembly.



6. Close the side cover.



NOTE: If you use thermal paper instead of label, you should choose 'RECEIPT' in 'System Set'. Please refer to chapter 9.2 'System set'.

6.3.3 Linerless Paper Installation

Note: The linerless paper printing module is different from the receipt and label printing module. If customers bought was the receipt or label printing module, but now want to replace it to the linerless paper module, please contact the service department.

Please pre-set the related items when you print linerless paper.

- 1) Press "System set" for seconds to enter the related setting, and then press key "←" "→" till the LCD display "Gap paper" and choose "Yes", and then press the key "Print/Enter" to confirm.
- 2) Press "System set" for seconds to enter the related setting, and then press key "←" "→" till the LCD display "paper type", please choose "black label", and then press the key "Print/Enter" to confirm.

2. Open the side cover and rotatable printing



1. Load the paper like the map shows (directly lead the thermal paper to the paper

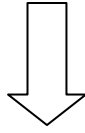

3. Close the rotatable printing assembly

4. Close the side cover



6.4 Printer Replacement

If the printer is damaged, you can follow the steps below to replace a new one.

Precaution:

- Before you do the following operations, please cut the power supply first.
- Do not disassemble, assemble or adjust the printer if it is operating satisfactorily. In particular, do not carelessly loosen the screws holding various parts in place.
- When servicing, be sure not to leave used parts or screws, etc.

1. Demount the damaged printer



Open the printer cover.

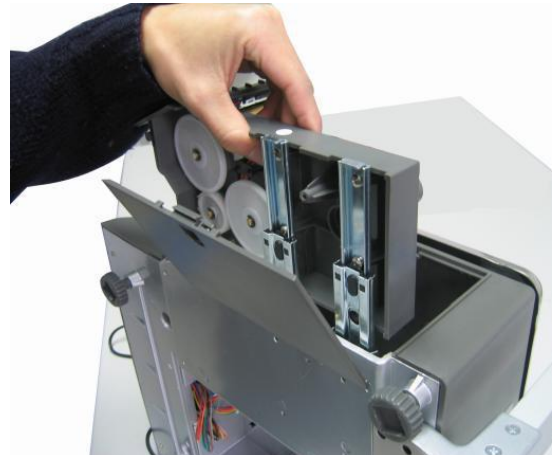

Pull out the printer

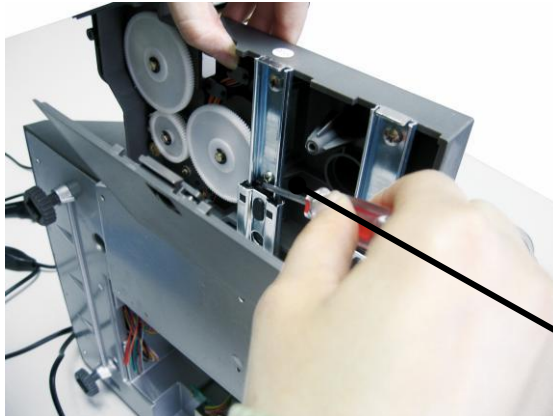

Use a screwdriver to push the latch to the left side.

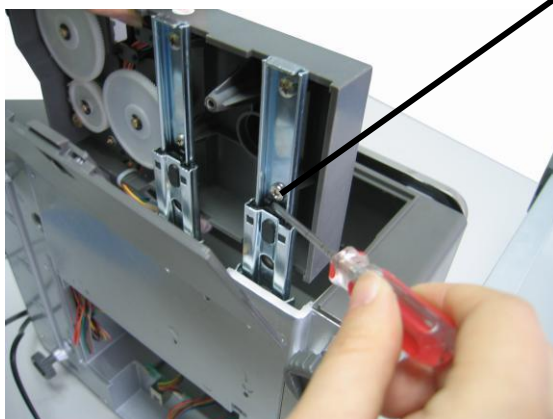



Lift up the printer

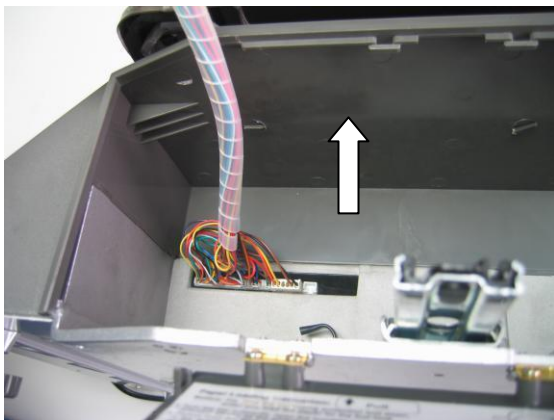
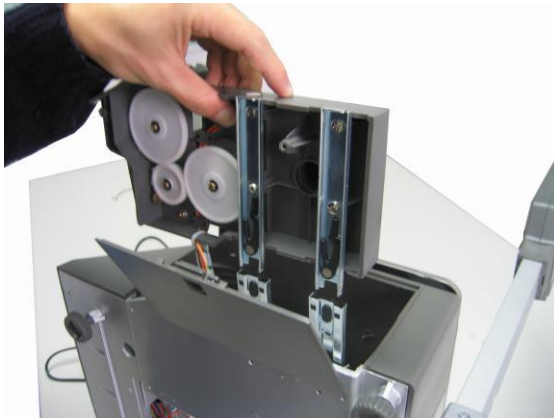

Pull out the cable



2. Install a new one

Install new printer by following the demount procedure in reverse order.

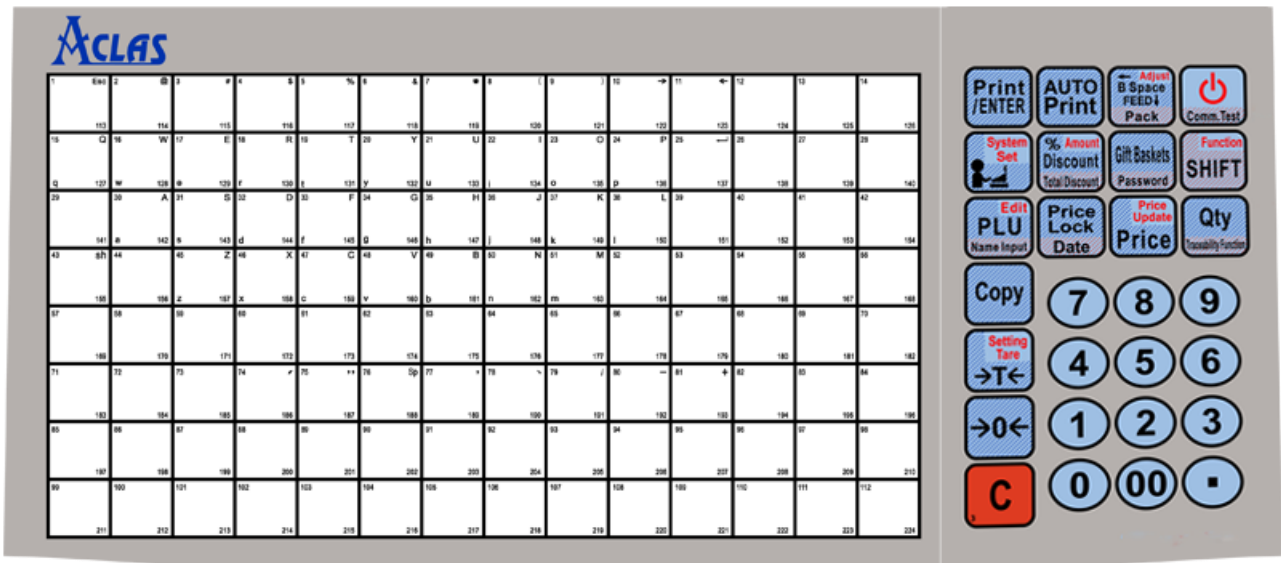
7 KEYBOARD LAYOUT



Note:

- 1) Press “” key for 2 seconds; the scale will adjust the paper’s position automatically; you yourself can also press it to adjust the paper minitrimly.
- 2) If the paper’s position is inaccurate after pressing the “” key for the first time, please press this key again to relocate the paper’s position.

8 POWER ON/OFF

On/Off with Button

At the first ten seconds after you turn on the scale, the LCD displays from “9” to “0” to enter self-testing. Please wait and do not press any key, system initialization is going on.



Press On/Off key at the left bottom of the machine after connecting the electricity

Note: do not press any other keys when do self-checking, because it will change the set of the scale and make the scale doesn’t work.

“On/Off” key is used to turn on or turn off the scale softly. Press this key and hold it for 2 seconds to turn off the scale, and so as how to turn down it. (Note: this key takes effect by the condition that the plug has connected and the power switch under the scale is turned on.)

Soft On/Off : Press  with 2 seconds.

We suggest that you should use On/Off key to turn On/Off the scale, and do not pull out the power plug directly if it hasn’t been softly turned down, especially if the scale is under the conditions of connecting with network or downloading data. PERATION

9 SALES OPERATION

9.1 Calculate by Weight

There are three kinds of operation. If PLU data is downloaded by background server PC or pre-edited in the scale, operation follows method 1 or method 2. Otherwise the operation follows method 3.

Notes:

- AUTO state:** On the condition that the weight and the unit are nonzero and after the weight is steady, a label will be printed. When power on, "AUTO" signal is lighted, which means the scale is in "AUTO" state. Press "AUTO" key to switch off the state. Suggest making "AUTO" state as default state.
- ZERO state:** There is nothing on the pan. Press "ZERO" key to let the weight zero and the "ZERO" signal will be on.
- Usage of Print key:** All of the following operations including Calculate by Weight, Tare Operation, and Calculate by Piece, Discount, and Change Price are in the "Auto" state. If the default state is not "Auto" state, the Auto arrow on the LCD won't be lightening, you must press Print key in order to print the label.

METHOD 1: HOTKEY OPERATION

Trade example: Some onions weighing 2.000kg are sold . Its hotkey is 01, and price is 0.500\$/kg.

OPERATION STEP	KEY	ARROW		DISPLAY			REMARK
		Zero	Auto	Weight	Unit price	Total	
1. Press "ZERO" key to let the scale return to zero	Zero	◀		0.000kg	0.00	0.00	Ignore this step if the scale is in "ZERO" status.
2. Put the onions 2.000kg on the pan.				2.000kg	0.00	0.00	
3. Input the hotkey 01 of the onions through PLU keyboard	01			2.000kg	0.50	1.00	

NOTES:

- There are 224 hotkey. These hotkeys can be changed randomly and be printed in a sheet quickly by the background PC.
- The above operation is for the hotkeys from 1 to112. As to hotkeys from 113 to 224, the above operation step 3 should be changed as follows: Press "SHIFT" key and press the hotkey no. of the commodity. Other steps are the same.
- All PLU hotkey could be edited and printed from the PC software.

METHOD 2: General sales steps by inputting LFCODE.

Trade example: Some onions weighing 2.000kg are sold. Their LFCODE is 10, unit price is 1.500\$/kg.

OPERATION STEP	KEY	ARROW		DISPLAY			REMARK
		Zero	Auto	Weight	Unit price	Total	

1. Press “ZERO” key to make the scale return to zero.	ZERO	◀	◀	0.000kg	0.00	0.00	Ignore this step if the scale is in “ZERO” status.
2. Put the onions weighing 2.000kg on the pan.			◀	2.000kg	0.00	0.00	
3. Input LFCODE 10 of the onions through small keyboard.	10		◀	2.000kg	0.10	0.2	

METHOD 3: operation for PLU without settings.

Before operation, please do as following:

1. Press the System Set key for 3 seconds till a beep prompts out and press ‘enter’ key to confirm
2. Use “←” “→” to select ‘hardware set’
3. then use “←” “→” to choose item ‘label select (1~32)’, then please input label serial number that have edited and downloaded on label editor of PC.

OPERATION SETP	KEY	ARROW		DISPLAY			REMARK
		Zero	Auto	Weight	Unit price	Total	
1. Press “ZERO” key to make the scale return to zero state.	Zero	◀	◀	0.000kg	0.00	0.00	Ignore this step if the scale is in “ZERO” status.
2. Press “SHIFT” & “Name Input”, and then input PLU name and press “ENTER” to confirm	SHIFT Name Input ENTER	◀	◀	0.000kg	0.00	0.00	
3. Input unit price 2.00 through the small keyboard.	2 0 0	◀	◀	0.000kg	2.00	0.00	
4. Put on the commodity weighing 1.0kg.			◀	1.000kg	2.00	2.00	
5. Press key Print	Print		◀	1.000kg	2.00	2.00	

9.2Tare Operation

It is only applicable to the commodity packed in package or container such as eggs, beans or fruit and so on.

METHOD 1: Operation for commodity separated from container or package.

Trade example: A package of apples is sold. The hotkey of apples is 05, the net weight is 2.000kg and unit price is 6.000\$/kg.

OPERATION	KEY	ARROW			DISPLAY			REMARK
		Zero	Auto	Tare	Weight	Unit price	Total	
1. Put the container or package weighing 1.000 kg on the pan.			◀		1.000kg	0.00	0.00	
2. Press “→T←” key.	→T←	◀	◀	◀	0.000kg	0.00	0.00	
3. Put a package of apples weighing 2.000kg on the pan.			◀	◀	2.000kg	0.00	0.00	
4. Key in the hotkey 05 of apple through PLU keyboard.	05		◀	◀	2.000kg	6.00	12.00	

5. Take away the container and the apples on the tray, then press “→T←” key.		▲	▲		0.000kg	0.00	0.00	This step is to leave the weight-deducting state. The arrow of “tare” disappears.
--	--	---	---	--	---------	------	------	---

Note: 1 Please refer to the description of “Hotkey making” in software manual which can be seen in the disk attached.

2 please refer to the “Tare edition and download” in software manual which can be seen in the disk attached.

METHOD 2: Operation for commodity that its tare weight is known but could not separated from container or package.

Trade example: A package of apples is sold. The unit price is 6.000\$/kg, the tare weight is 1.000kg. The weight of apple and package is 2.000kg.

OPERATION	KEY	ARROW			DISPLAY			REMARK
		Zero	Auto	Tare	Weight	Unit price	Total	
1. Press “→0←” key.		▲	▲	▲	0.000kg	0.00	0.00	Ignore this step if the scale is in “ZERO” status.
2. Input the tare weight through small keyboard.		▲	▲		0.000kg	10.0 0	0.00	
3. Press “→T←” key			▲	▲	-1.000kg	0.00	0.00	
4. Put a package of apples on the pan.			▲	▲	1.000kg	0.00	0.00	
5. Key in the hotkey 05 of apple through PLU keyboard.			▲	▲	1.000kg	6.00	6.00	
6. Take away the container and the apples on the tray, then press “→T←” key.		▲	▲		0.000kg	0.00	0.00	This step is to leave the weight-deducting state. The arrow of “tare” disappears.

METHOD 3: Operation for commodity that its tare weight is known and has been set in software but could not separated from container or package.

Trade example: A package of apples is sold. The unit price is 6.000\$/kg, the tare weight is 1.000kg. The preset number of tare weight is 1. The weight of apple and package is 2.000kg.

OPERATION	KEY	ARROW			DISPLAY			REMARK
		Zero	Auto	Tare	Weight	Unit price	Total	
1. Press “→0←” key.		▲	▲	▲	0.000kg	0.00	0.00	Ignore this step if the scale is in “ZERO” status.
2. Press key “1” from the small keyboard, and then press “SHIFT” key and “→T←”key.	 		▲	▲	-1.000kg	0.00	0.00	
4. Put a package of apples on the pan.			▲	▲	1.000kg	0.00	0.00	

5. Key in the hotkey 05 of apple through PLU keyboard.	<input type="text" value="05"/>		◀	◀	1.000kg	6.00	6.00	
6. Take away the container and the apples on the tray, then press "→T←" key.	<input type="text" value="→T←"/>	◀	◀		0.000kg	0.00	0.00	This step is to leave the weight-deducting state. The arrow of "tare" disappears.

9.3 Calculate by Piece

There are two kinds of operation methods. Method 1 is for hot key sale and method 2 is suitable for sale by LFCODE.

Note: Set the price unit into PCS/kg in the PC software before taking the following operations.

METHOD 1: Hotkey operation step

Trade example: Ten pieces of cake are sold. The hotkey of cake is 05. The unit is PCS/kg.

OPERATION	KEY	ARROW		DISPLAY			REMARK
		<input type="text" value="Zero"/>	<input type="text" value="Auto"/>	Weight	Unit price	Total	
1. Input the number of the commodity through small keyboard. For example 10.	<input type="text" value="10"/>	◀	◀	0.000kg	0.10	0.00	
2. Press "Qty" key.	<input type="text" value="Qty"/>	◀	◀	0.000kg	0.00	0.00	The LCD returns to initial state after "Qty" key is pressed.
3. Press the corresponding hotkey 05 of the cake through PLU keyboard.	<input type="text" value="05"/>	◀	◀	0.000kg	3.00	30.00	

METHOD 2: general operation step

Trade example: Ten pieces of cakes are sold and the LFCODE of the cake is 12. The unit price is 3.00PCS/kg. The unit is PCS/kg.

OPERATION	KEY	ARROW		DISPLAY			REMARK
		<input type="text" value="Zero"/>	<input type="text" value="Auto"/>	Weight	Unit price	Total	
1. Input the number of the Cake 10 through small keyboard.	<input type="text" value="10"/>	◀	◀	0.000kg	0.10	0.10	
2. Press "Qty" key.	<input type="text" value="Qty"/>	◀	◀	0.000kg	0.00	0.00	The unit must be PCS.
3. Input LFCODE of the cake 12 through small keyboard.	<input type="text" value="1"/> <input type="text" value="2"/>			LLFCOD E? (1-6)	12		
4. Press "PLU" key	<input type="text" value="PLU"/>	◀	◀	0.000Kg	3.00	30.00	Ignore this step if the LFCODE has 6 digits.

9.3 Discount

The scale supports two kinds of discount: % discount and total discount. This function can be locked by password which is set and can be randomly changed by background server PC.

● % discount

Trade example: some peaches give a discount of 95. Its unit is 8.0\$/kg and hotkey is 12.

OPERATION	KEY	ARROW		DISPLAY			REMARK
		<input type="text" value="Zero"/>	<input type="text" value="Auto"/>	Weight	Unit price	Total	

1. Input discount proportion of the commodity $\boxed{9}$ $\boxed{5}$ through numeric keyboard.	$\boxed{9}$ $\boxed{5}$	◀	◀	0.000kg	0.95	0.00	
2. Press $\boxed{\%Discount}$ key.	$\boxed{\%Discount}$	◀	◀	0.000kg	0.00	0.00	The LCD returns to initial state after $\boxed{\%Discount}$ key is pressed.
3. Put the commodity weighing 1.000kg on the			◀	1.000kg	0.00	0.00	
4. Key in the corresponding hotkey of the peaches e.g. 12.	$\boxed{12}$		◀	1.000kg	8.00	7.60	

Notes:

As for step 3 and 4, please refer to the operation of ‘calculate by weight’. You can choose other kinds of operation such as normal operation or operation for pre-edited PLU to proceed with the above operation.

● **Total discount**

OPERATION	KEY	ARROW		DISPLAY			REMARK
		\boxed{Zero}	\boxed{Auto}	Weight	Unit price	Total	
1. Press key \boxed{SHIFT} & $\boxed{Total Discount}$. Input the discount amount 1\$, and then press key \boxed{ENTER} .	\boxed{SHIFT} $\boxed{Total Discount}$ \boxed{ENTER}		◀	0.000kg	0.00	0.00	The LCD returns to initial state after $\boxed{Total Discount}$ key is pressed.
2. Put the commodity weighing 1.000kg on the pan.			◀	1.000kg	8.00	8.00	
3. Key in the corresponding hotkey of the peaches e.g. 12.	$\boxed{12}$		◀	1.000kg	7.00	7.00	

9.4 Name Input Function

This function is used to sell the commodity temporary.

Step 1: Press [SHIFT] key, and then press [Name Input] key.

Step 2: Input the PLU name according to the display screen indicating.

Step3: press ‘enter’ key to confirm (Please take reference to page18: method 3)

9.5 Change Price

Change the unit price of a commodity. There are two methods to change the unit price of a commodity, they are permanently change price and temporarily change price.

9.5.1 Date

Example: the valid date of a cargo is 2013.05.30, now customer wants to modify it to 2013.06.10, please do the following:

Before modification on scale directly, this cargo’s original valid date has been set on PC before and please takes reference to chapter 6.7 of PC user manual.

Step 1: put cargo on scale first.

Step 2: Input valid date wanted to extend, number ‘10’

Step3: Press [SHIFT] key, and then press [DATE] key.

Step 4: press PLU hotkey of this cargo.

9.5.2 Permanently Change Price

METHOD 1:

Trade example: The unit price of the apples 4.000\$/kg. After changing price, its unit price is 3.000\$/kg and the hotkey is 05.

OPERATION	KEY	ARROW		DISPLAY		
		Zero	Auto	Weight	Unit price	Total
1. Key the hotkey 05 of the apples via PLU keyboard.	05	◀	◀	0.000kg	4.00	0.00
2. Long press Price Update key 1.5s.	Price Update			? PRICE?	0.00	0.00
3. Key in the new price 3.000\$/kg on the numerical keyboard.	3 0 0			? PRICE?	3.00	0.00
4. Press Print/Enter key.	Print/Enter	◀	◀	0.000kg	3.00	0.00
5. Proceed with the normal operation of weighing or granular price calculating.						0.00

METHOD 2:

Trade example: Some apples are sold. The unit price of the apple is 4.000\$/kg, and LFCODE is 900001. After change the unit price, the unit price of the apple is 3.000\$/kg.

OPERATION	KEY	ARROW		DISAPPLY		
		Zero	Auto	Weight	Unit price	Total
1. Long Press Price Update key.	Price Update			LLFCODE? (1-6)		
2. Key in the LFCODE 900001 of the apples through small keyboard.	900001			? PRICE?	900001	
3. Key in the price changed 3.00/kg.	3 0 0			0.000kg	3.00	
4. Press Print/Enter key.	Print/Enter	◀	◀	? PRICE?	0.00	
6. Proceed with the normal operation of 'calculate by weight' or 'calculate by piece'.						

9.5.3 Temporarily Change Price

Note: before price change operation, please open price change function first.

- | |
|---|
| 1. Long press 'system set' key to enter 'Edit Menu' |
| 2. Enter PLU edit. |
| 3. Input LFCODE(1~6) and press 'enter' key |
| 4. Use key [→] or [←] to select "Flag" and press 'enter' key |
| 5. Use key [→] or [←] to select 'YES' and then press 'enter' key to confirm |
| 6. Press 'Clear' key to exit to 'Flag', press hotkey 'S and press 'enter' key to confirm. And the PLU is available to change price. |

METHOD 1:

Trade example: Some apples are sold. The unit price of the apple is 4.000\$/kg, and its hotkey is 10. After change the unit price, the unit price of the apple is 3.000\$/kg. When finish this dealing, it will recover to the original price 4.000\$/kg

Note: before price change operation, please open price change function first.

OPERATION	KEY	ARROW		DISAPLY			REMARK
		Zero	Auto	Weight	Unit price	Total	
1 Key the hotkey 10 of the apple via PLU keyboard.	10	◀	◀	0.000kg	4.00	0.00	
2. Short Press Price key.	Price	◀	◀	0.000kg	0.00	0.00	Prompts temporarily change price.
3. key in the new price 3.0\$/kg and press enter to confirm.	3.000 Print/Enter	◀	◀	0.000kg	3.00	0.00	Press 'enter' key and weigh the apple, can automatically print the apple, the unit price is 3.00.
5. Press '05' key after finish this operation, and the unit price of the apple is \$4.00/kg.							

METHOD 2:

Trade Example : The unit price of the cheese is 4.000\$/ kg, and LFCODE is 15. Change the unit price of the cheese as 3.000\$/kg. When finish this dealing, it will recover to the original price 4.000\$/kg.

OPERATION	KEY	ARROW		DISAPLY			Note
		Zero	Auto	Weight	Unit price	Total	
1.Short press Price key.	Price						
2. Put the commodity weighing 1.000kg on the pan.				1.000kg	0.00	0.00	
3. Key in the LFCODE 15 of the commodity via small keyboard.	15			1.000kg	0.15	0.15	
4. Press 'enter' key	Print/ENTER						?Temporarily Change Price?
5. Key in the new price 3.0 \$/kg.	3.000			?PRICE?	3.000	3.00	You can press key "15" to make sure whether is unit price is back to 4.00/kg.

Trade Example 2: Temporarily change the PLU whose initial unit price is 0\$/kg, sell with LF-code. Suppose the initial price of the cherry is 0\$/kg, and now temporarily change it as 30.0\$/kg, and its LF-code is 13. When finish this dealing, it will recover to the initial price 0\$/kg.

OPERATION	KEY	ARROW		DISAPLY			REMARK
		Zero	Auto	Weight	Unit price	Total	
1. Put the cherry weighted 1kg onto the scale.			◀	1.000kg	0.00	0.00	
2. Input LF-code 13 via the numeric keypad.	13		◀	1.000kg	0.13	0.00	PLU with unit price 0\$/kg can't be sell directly.
3. Press key PLU	PLU			1.000kg	0.00	00.00	

4. Input the new price 30\$/kg	3 0 0 0			1.000kg	30.00	30.00	
5. Press Print key.	Print		←	1.000kg	30.00	30.00	



METHOD 3: Temporarily sell the PLU needed to be weighted with PCS.

Trade Example: The unit price of the cabbages is 1\$/kg in the morning, and it should be change price as 1\$/PCS in the evening to promote it. When finish this dealing, it will recover to its initial price 1\$/kg. Suppose a cabbage is 3kg, and its hotkey is 13.

OPERATION	KEY	ARROW		DISAPLY			REMARK
		Zer	Auto	Weight	Unit price	Total	
1. Put the cabbage onto the scale.			←	3.000kg	0.00	0.00	Sell by PCS now.
2. Input the new price 2.00 on the numerical key.	2 0 0		←	3.000kg	2.00	6.00	
3. Press SHIFT + Comm.Test key	SHIFT + Comm.Test		←	3.000kg	0.00	0.00	
4. Press the hotkey 13 of the cabbage via PLU keyboard.	1 3		←	3.000kg	2.00	2.00	

10 General Using Key

Name	Function	Operati on	Note
C	1.usually use to clear unit price. 2.clear abnormal picture or error information, and make the system back to normal state.	Press key C	
Comm. Test	Use to test whether the internet is normal and in time to deal with PLU weighing	Press this key one second, if success, after “beep” sound, the display will prompts “Normal”. Weighing PLU sales by PCS.	
Auto Print	Automatically print label	Select auto print by press shift key, and cancel the function by press again	It is on auto print condition when power-on, and press auto print key again to exit the function.
← B Space FEED ↓	Control the in/out of the paper; to place the labels; Input price or other information when do PLU edition, press this key can cancel the last operation.	One press can adjust the paper, long press will send out one paper and the scale will adjust the place of the label automatically ← B Space: when	When meet the condition that do not send out labels or not completely send out labels during printing, long press this key to set the label again.

		edit PLU, input the unit price 5, press this key, the price will be 5.	
	This key has searching function, that is looking for the related item of the current field(hotkey 10, 11).Long press 'system set' to enter system set, and use these two keys to select the function you want to start or change.	Press  check last item, Press  check next item	
Price Lock	Price lock key. The price will clear when weight becomes 0, so press LOCK can avoid competing input the price when do weighing continuously.	Press Price Lock can weighing the same PLU continuously(PLU will not miss)	Price Lock key is key for change, if you want to cancel something, press this key again.

11 SOME SIMPLE OPERATION

11.1 Copy price label

This operation fits for repeat printing the label of the PLU during weighing.

1. Press 'Copy' key and press 'enter' to confirm;
2. Input the number you want to print and press "Copy" key, then the corresponding number pieces of label is printed.
3. Press Copy key and input the number and press 'Copy' key to print the label you want. If you want to stop printing, press 'Clear' key.

11.2 Print receipt

1. Reloaded the rolling paper and extend its head out of the outlet. Make sure not roll the paper head in the rewinder. Please refer to Chapter 6.3.2 Receipt Paper Installation .
2. Press the System Set for two seconds and then use "←" "→" to select the item „SYSTEM SET“ + ENTER key to enter the system setting state. Use "←" "→" to select "HARDWARE SET"+ Enter key to select "PAPER" +. ENTER key. Use key [→] or [←] to select the paper type as 'RECEIPT'.
3. Press Enter key to confirm.

Note:

If you want to use label paper again, you should enter this function to select the paper type as 'LABEL', and after setting you must restart the scale by press the on-off on the scale's bottom (switch to 'RECEIPT' no need restart the scale)

11.3 Normal Package

✓ This is suitable to quickly print label of the same type with different weight.

1. Start up the function of “Auto” and “Price lock” (these two indicator light are lighting)	
2. Select PLU or input the unit price.	
3. Put the commodity (to be packed) on the pan and the label will be printed automatically.	
Note: the operation of the right is suggested if you want to operate quickly.	1. Put commodity 1 on the pan
	2. After the label is printed automatically put commodity 2 on the pan at the same time, take away commodity 1.
	3. Take away the label and stick it on commodity 1. The label of the commodity 2 will be printed out.
	4. Put commodity 3 on the pan and take away commodity 2.
	5. Take away the label and stick it on commodity 2, the next label will be printed.
	6. Repeat as the above steps to overlap the time of waiting for printing label and sticking label.

✓ This is suitable to quickly stick several labels on the packed commodity

1. Open label edit, setup one new No 32 label, that is ‘package label’, the content of the label can be defined according to your need;
2. Click to download the label
3. Sell one PLU;
4. Press ‘Shift’ key + ‘Package’ key to print corresponding labels (serial number increase after printing one label; the package label serial number will be calculated newly when newly sell the PLU).

11.4 Package by Fixed weight

Fix weight package, this function is available by setting on PC software first.

For example: pack fish by the fixed weight 0.255kg, and the corresponding hotkey is 38.

Note: Before operate on the scale, please press key Price Lock first, and the indicator light for ‘price lock’ will be lighting.

OPERATION	KEY	ARROW			Display			Remark
		Zero	Auto	Fix Weight	Weight	Unit Price	Total	
1. Put the fish on the pan.			◀	◀	0.255kg	0.00	0.00	
2. Press the hotkey 38 of the fish via PLU keyboard.	3 8		◀	◀	0.255kg	70.00	17.85	

Attention: It is the actual weight of the PLU, the unit display the package weight by fixed weight sale, total price = package weight * actual unit price of the PLU. The commodity can be sold at the condition that its weight is between the weight tolerance $\pm 10\%$ kg while it is in Fixed Weight package mode. (When the actual weight is below 0.3382 or over 0.3738, the commodity cannot be sold and the label cannot print.)

11.5 Package by Fixed Price

Fix price package, this function is available by setting on PC software first.

OPERATION	KEY	ARROW			DISPLAY			RE MARK
		Zero	Auto	Fix Price	Weight	Unit Price	Total	
1. Put the fish on the pan.			◀	◀	1.000kg	0.00	0.00	

2. Press the hotkey 38 of the fish via PLU keyboard.	38		◀	◀	1.000kg	10.00	10	
--	----	--	---	---	---------	-------	----	--

Attention: It is the actual weight of the PLU, the unit display the package weight by fixed price sale, total price = unit price of the PLU. The commodity can be sold at the condition that its total price is between the package tolerance $\pm 10\%$ kg while it is in Fixed Price package mode. (When the actual weight is below 0.95 or over 1.05, the commodity cannot be sold and the label cannot print.)

11.6 Gift Baskets Function

Gift basket function is usually used in the aspect, such as pack gift-box and fruit-dish. Set a hotkey as 'gift baskets' first on the PC software first.

1. Open PLU manager, set the LFCODE of the "gift basket" as 950002:

Input "Gift Basket" into name column; set unit price as 0; set package type as "package by weight"; input package weight 0.

For example: Package a fruit-dish (apple, grape, and orange)

PLU name: apple weight unit: kg unit price: 10.00 \$/kg hotkey 06

PLU name: orange weight unit: kg unit price: 4.00 \$/kg hotkey 07

PLU name: grape weight unit: kg unit price: 20.00 \$/kg hotkey 08

Suppose each of the three fruits is 1.000kg.

OPERATION	KEY	DISPLAY			REMARK
		Weight	Unit Price	Total	
1. Press hotkey 01		0.000kg	0.00	0.00	After listening long sound 'beep', enter gift sale mode.
2. Put the apple on the pan, and press hotkey 06	06	1.000kg	10.00	10.00	
3. Put the orange on the pan, and press hotkey 07	07	1.000kg	4.00	4.00	
4. Put the grape on the pan, and press hotkey 08	08	1.000kg	20.00	20.00	
5. Press hotkey 01	01	0.000kg		0.00	Print sum account label.

When the value of the package weight column is 1, every commodity of the basket will print one piece of label during weighing process, and print one sum account label finally.

Note: Under hand printing mode, press 'print' key every time you press hotkey after place the commodity.

OPERATION	KEY	DISPLAY			DISPLAY
		Weight	Unit Price	Total	
1. Short press "gift basket"		0.000kg	0.00	0.00	
2. Input LFCODE 950002		0.000kg	0.00	0.00	
3. Short press "enter"		0.000kg	0.00	0.00	After listening long sound 'beep', enter gift sale mode
4. Put the apple on the pan, and press hotkey 06	06	1.000kg	10.00	10.00	Automatically print apple sale label
5. Put the orange on the pan, and press hotkey 07	07	1.000kg	4.00	4.00	Automatically print apple sale label

6. Put the grape on the pan, and press hotkey 08	08	1.000kg	20.00	20.00	Automatically print apple sale label
7. Press “gift basket”		0.000kg		0.00	Print sum account label.

11.7 Traceability Function

This function is used to modify the traceability information temporary. This function should be activated from the item ‘System Set’. Operation steps are as follows:

Step1: Press [SHIFT] key and then press [Traceability Function] key.

Step2: Input LLFCODE and the screen will display “LLFCODE”, press [ENTER] key, the screen will display “Trace code”, press [ENTER] key.

Step3: The screen will display “Date”, press [ENTER] key. Input Date and then press [ENTER] key. YY-year, MM-month, DD-day.

Step4: The screen will display “Born Country”, press [ENTER] key. Input Born Country.

Step5: The screen will display “Bred Country”, press [ENTER] key. Input Bred Country.

Step6: The screen will display “Slaughter house”, press [ENTER] key. Input Slaughter house.

Step7: The screen will display “Cutting Hall”, press [ENTER] key. Input Cutting Hall.

Step8: The screen will display “Save”, press [ENTER] key.

Step9: The screen will display “Replace”, press [ENTER] key.

12 FUNCTION SET

12.1 PLU Set

Notes: This operation can be locked by password that is set in background PC changed randomly.

◆ PLU Input

1. Press PLU key and release it till a beep prompts out . The display shows “LFCODE”, it means the system is in the state of editing PLU.
2. When the display prompts “LFCODE?”, and presses <u>Enter</u> to confirm. Then the display shows “NAME” and enter editing items: N/L/C/P/U/F/T/B/D/W/Y/M/G/I/R/S, you can use key ← and → to choose the item you want to edit, then press <u>Enter</u> .
3. Press <u>Enter</u> key. Input the corresponding data by sequence. Refer to the following notes.
4. Press <u>S</u> or <u>Enter</u> to save the above operation.

NOTES: the following is the sequence of PLU data input. When one item is input, press Enter to confirm. The system will shift to another item, and press Enter again to enter it. If no contents are inputted, press ESC to exit.

- 1) L---LIFCODE: select LIFCODE from(1-6)
- 2) N---PLU NAME, NAME2, NAME3 : Input PLU name not exceeding 36 characters directly through keyboard. And through the numeric keyboard input the code of the input characters. The code is in the word stock table.
- 3) C---PLU CODE: Input PLU code within 10 digits.
- 4) P---UNIT PRICE: Input PLU price.
- 5) L---LIMIT MAX SCALE PRICE: set max scale price
- 6) U---UNIT: Select price unit from g, 10g, 100g, kg, Lb and Oz or PCS (g), PCS (kg), PCS (Lb) and PCS (Oz).
- 7) F---SHELF: Input the shelf-time of PLU: period from 0 to 365---means its unit is ‘day’; period from 1000 to 9999---means its unit is ‘hour’. e.g. input 60, which stands for its shelf-time is 60-day; input 1006, which means its shelf-time is 6-hour.
- 8) V---VALID DAYS---to set valid days for goods.

- 9) T---TARE WEIGHT: Choose tare weight mode (normal, weight, table)
- 10)B---BAR CODE, BARCODE2 : Select bar code type from 1 to 99.
- 11)D---DEPARTMENT: Input department code from 0 to 99.
- 12)G---GROUP: select group number from 0 to 99.
- 13)O---ORIGIN: set origin number from 0-500
- 14)W---PACKING WEIGHT: Input the package weight.
- 15)Y---Packing Type: Use key “←”“→”to select (Normal; fixed weight; fixed price; both) weight and price.
- 16)R---RANGE: set PLU range scope
- 17)T---TEXT1 .TEXT2,TEXT3,TEXT4,TEXT5,TEXT6,TEXT7,TEXT8
- 18)I---LABEL SELECT (Set label of corresponding PLU) Use key “←”“→”to select (DEF, D0, D1,D0D1).
- 19)D---DISCOUNT: choose discount mode (normal.rate,table)
- 20)P---PRODUCT DATE: set product date
- 21)F---FLAG: set flag contents
- 22)DISCOUNT 1/2 PLU
- 23)DISCOUNT 1/4 PLU
- 24)H---HOTKEY: set hotkey
- 25)R---Set PLU discount (-10~125).
- 26)S---Save PLU revision.

◆ PLU Data Revise

1. Press PLU key for two seconds. The display shows “PLU EDIT”, it means the system is in the state of editing PLU.
2. Key in LFCODE when the display prompt “LLFCODE?”, and press Enter to confirm. Then the display shows “NAME” and enter editing items: N/L/C/P/U/F/T/B/D/W/Y/M/G/I/R/S, you can use key ← and → to choose the item you want to edit, then press Enter.
3. Key in the corresponding letter of the item to be modified, refer to the above notes, for example, key in N to modify name and P to modify price.
4. Input the new information.
5. Press S key to save the above results. Else they are abandoned.

12.2 System Set

Note: This operation can be locked by password set in background PC server and is changeable as will.

12.2.1 Edit Menu

1. Press the System Set key till a beep prompts out
2. Use “←” “→” to select ‘Edit Menu ’
3. Press Enter key to confirm

NOTES: the following is the sequence of edit menu. When one item is input, press **Enter** to confirm. The system will shift to another item, and press **Enter** again to enter it. If no contents are inputted, press **ESC** to exit.

NOTES: the following is the sequence of edit menu. When one item is input, press **Enter** to confirm. The system will shift to another item, and press **Enter** again to enter it. If no contents are inputted, press **ESC** to exit.

Notes:

1. P---PLU EDIT :to edit PLU information here
2. T---TARE EDIT: to set certain tare information by inputting the corresponding index number
3. D---DISCOUNT: to set certain discount information by inputting the corresponding index number

4. EDIT MESSAGE (NOTE1): Input LLFCODE, and then edit message
5. INGREDIENT (NOTE2) EDIT: Input LLFCODE, and then edit ingredient
6. EXTRA MESSAGE (NOTE3) EDIT: Input LLFCODE, and then edit extra message
7. NOTE4---edit the information you want.
8. D---DEPARTMENT: to set certain department information by inputting the corresponding index number
9. G---GROUP: to set certain group information by inputting the corresponding index number
- 10.L---LCD ADVISE EDIT
- 11.H---HEAD EDIT: to edit head message information
- 12.T---TALL EDIT: to edit tall information
- 13.N---NUTRIENT FACTS TABLE EDIT: to edit nutrient facts information by inputting PLU index
- 14.I---INGREDIENTS FACTS EDIT: to set nutrient facts information by inputting the corresponding index number
- 15.P---PRINT PLU LFCODE: set PLU LFCODE printing

PLU EDIT

1. Press the System Set key till a beep prompts out
2. Use “←” “→” to select ‘Edit Menu ’ and press ‘enter’ key to confirm
3. Use “←” “→” to select ‘PLU EDIT’ and press Enter key to confirm

In this section, you can set your PLU information.

- 1) Input LFCODE number and press ‘enter’ key to confirm



Press ‘enter’ key

- 2) Input ‘NAME’ and press ‘enter’ key to confirm



Press ‘enter’ key

- 3) Input ‘NAME 2’ and press ‘enter’ key to confirm



Press ‘enter’ key

- 4) Input ‘NAME 3’ and press ‘enter’ key to confirm



Press ‘enter’ key

- 5) Input ‘PLU CODE’ and press ‘enter’ key to confirm



Press ‘enter’ key

- 6) Input ‘UNIT PRICE’ and press ‘enter’ key to confirm



Press ‘enter’ key

- 7) Input ‘LIMIT MAX SALE PRICE’ and press ‘enter’ key to confirm, you can switch digits by pressing numerical key ‘0’.



Press ‘enter’ key

- 8) Input ‘UNIT’ of PLU and press ‘enter’ key to confirm (press ‘→←’ key to select unit price kg; g, 10g; 100g, 50g; ounce; pound; 500g; TaiWan Jin; press ‘enter’ key to confirm.).

 Press 'enter' key

9) Choose 'TARE WEIGHT' mode (1 Normal. 2 Table) and press 'enter' key to confirm.

 Press 'enter' key

10) Input 'Tare' and press 'enter' to confirm.

 Press 'enter' key

11) Input 'BARCODE', then press 'enter' to confirm.

 Press 'enter' key

12) Input 'BARCODE2' and set barcode, then press 'enter' to confirm.

 Press 'enter' key

13) Input 'DEP (0-99)' number, then press 'enter' to confirm.

 Press 'enter' key

14) Input 'PACKAGE WEIGHT', then press 'enter' to confirm.

 Press 'enter' key

15) Use '→←' key choose 'PACKAGE TYPE' mode (1 Normal; 2 Fixweight; 3 FixPrice; 4 Both fix) and press 'enter' key to confirm.

 Press 'enter' key

16) Input acceptable 'RANGE' and then press 'enter' to confirm.

 Press 'enter' key

17) Input the information of 'TEXT1 ,2 ,3 ,4 ,5, 6,7 ,8' and then press 'enter' to confirm.

 Press 'enter' key

18) Set 'LACK LABEL' number and press 'enter' to confirm.

 Press 'enter' key

19) Input 'LABEL SELECT' number and press 'enter' to confirm.

 Press 'enter' key

20) Set 'DISCOUNT' information, use '→←' key to choose discount mode (1 Normal, 2 Rate, 3 Table) and then press 'enter' to confirm.

 Press 'enter' key

21)Set 'SHELF' and then press 'enter' key to confirm



Press 'enter' key

22)Input 'VALID DAYS' of PLU and then press 'enter' key to confirm



Press 'enter' key

23)Input 'group (0-99)' number, then press 'enter' to confirm.



Press 'enter' key

24)Input 'PRODUCTION DATE', then press 'enter' to confirm.



25)Input 'origin (0-500)' number

Press 'enter' key



Press 'enter' key

26)Input 'PRODUCT DATE'(YYYYMMDDhhmm), Y: year; M: month; D: day; h: hour; m: minute, input the date according to aboved format, then press 'enter' to confirm.



Press 'enter' key

27)Input discount rate one by one when do the operation of 'DISCOUNT 1/2 PLU' or 'DISCOUNT 1/4 PLU', then press 'enter' to confirm.



Press 'enter' key

28)Set 'FLAG', to confirm whether the information of the PLU you edit will print out on the final label. (It contains 'TEXT1---TEXT8' message/sale message/ingredients/product date/ pack time/shelf day/price change/shelf column (count by day or time) No: by daytime Yes; by time/shelf time/ limit sale price)

Egg: sale message? Select (1 YES; 2 NO), use '→←' to select YES or NO, and then press 'enter' to confirm. After finishing the deal, the 'sale message' will be print out on the PLU label. If you want to enter the next item 'ingredients', press '→←' key.



Press 'enter' key

29)After edition, select 'save' (the edition information will be saved after this operation), and press 'enter' key to confirm, use '→←' key to find the save menu or use shortcut (hotkey 'S' on the right side) to choose the save menu.

After finishing the edition, back to the Link Edition, to make the label for the information you want to print out on the label and upload to the scale. Then, the sold PLU will be print out at the format of the label edit via LINK. Check the PC software management for the details

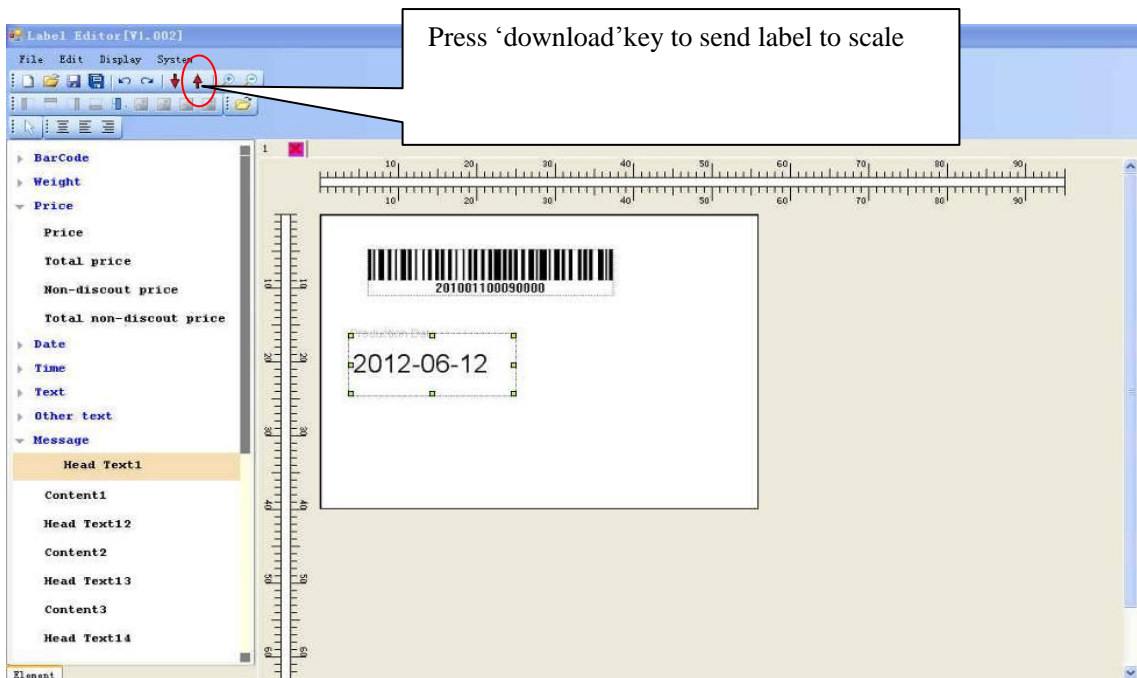
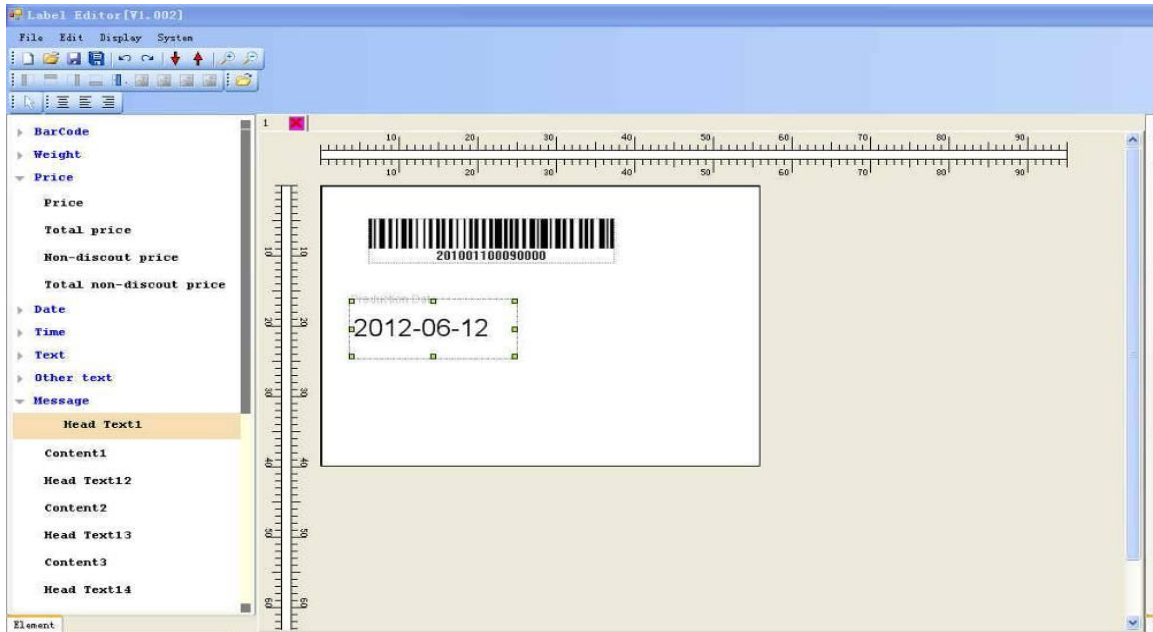

TARE EDIT

1. Long press the System Set key till a beep prompts out
2. Use “←” “→” to select ‘Edit Menu ’and Use “←” “→” to select ‘TARE EDIT’
3. Input ‘index’ number , Eg: input INDEX 1 and press ‘enter’ to confirm
4 . Press ‘enter’ to confirm

If you want to quit edition, please press ‘ESC’ to exit edition interface and you can input index number to check the information you have set.

DISCOUNT

1. Long press the System Set till a beep prompts out
2. Use “←” “→” to select ‘Edit Menu ’
3. Press Enter key and Use “←” “→” to select ‘DISCOUNT’ and press ‘enter’ to confirm

The interface then will prompts “DISC 1”(happy time 1 on PC manual ,please take reference to chapter 6.4) and you can change to DISC 2 and DISC 3(happy time 2,happy time 3)by pressing “←” “→” key.

We here take DISC 1 edition for example:

Display	steps
INDEX	Pressing ‘enter’key and input index number
DISC1	Pressing ‘enter’key to enter discount edit
?0:OFF 1:ON?	Choose type1 (Price*discount %+)and press ‘enter’ to confirm
‘?TYPE?’	Input corresponding number from number 0 to number 9. Eg, unit price %+ , directly input 1 and press ‘enter’ to confirm
‘?MIN TOTAL ?’	Input‘MIN TITAL’ value (pressing “0”to switch decimalpoint)and press enter to confirm
‘?MAX TOTAL?’	Input‘MAX TITAL’ value (pressing “0”to switch decimalpoint)and press enter to confirm
‘?MIN WEIGHT?’	Input‘MIN WEIGHT’ value (pressing “0”to switch decimalpoint)and press enter to confirm
‘MAX WEIGHT?’	Input‘MAX WEIGHT’ value (pressing “0”to switch decimalpoint)and press enter to confirm
‘0:PERIOD 1;TIME?’	Choose discount time 0:PERIOD 1;TIME .digit 0 means the cargo will be in discount in certain period and digit 1 means discount in certain time
?START(YYYYMMDDhhmm)	Input discount starting time in the form of YYYYMMDDhhmm
?END(YYYYMMDDhhmm)	Input discount ending time in the form of YYYYMMDDhhmm
?DISCOUNT?	Input discount rate and press ‘enter’ key to confirm

Then, the discount 1 is finished and the interface will change to DISC2 edition automatically.

Then, please enter PLU EDIT section to confirm if you want to save the above discount information

Edit Message (NOTE1)

Please take your reference to chapter 6.1.8 on PC manual

1. Long press the System Set key till a beep prompts out
2. Use “←” “→” to select ‘Edit Menu ’and press ‘enter’ key to confirm
3. Use “←” “→” to select ‘Sale Message Edit(NOTE1)’ and press ‘enter’ key to confirm

Eg:

Display	steps
?LFCODE?	Input live code and press ‘enter’ key to confirm
?line1 ...line8?	Input the information of line 1 to line 8 and press enter key, Use “←” “→” to swift the edition from line 1 to line 8
?Save?	Press ‘enter’ if you want to save the information you have set

INGREDIENTS (NOTE 2) EDIT

1. Long press the System Set key till a beep prompts out
2. Use “←” “→” to select ‘Edit Menu ’
3. Use “←” “→” to select ‘NOTE2 Edit’ and press ‘enter’ key.
4. Input ‘LF CODE?(1-6)’ and press ‘enter’ key
5. Input the information you want to set on “line1 to line8” and press enter key for final confirmation.
6 , if you want to ignore, please press “←” “→” to find ‘save’ word to save information

EXTRA MESSAGE (NOTE 3) EDIT

1. Long press the System Set key till a beep prompts out
2. Use “←” “→” to select ‘Edit Menu ’
3. Use “←” “→” to select ‘NOTE3 Edit’ and press ‘enter’ key.
5. Input ‘LF CODE?(1-6)’ and press ‘enter’ key
5. Input the information you want to set on “line1 to line8” and press enter key for final confirmation.
6 , if you want to ignore ,please press “←” “→” to find ‘save’ word to save information

NOTE4 EDIT

1. Long press the System Set key till a beep prompts out
2. Use “←” “→” to select ‘Edit Menu ’
3. Use “←” “→” to select ‘NOTE4 Edit’ and press ‘enter’ key.
6. Input ‘LF CODE?(1-6)’ and press ‘enter’ key
5. Input the information you want to set on “line1 to line8” and press enter key for final confirmation.
6 , if you want to ignore ,please press “←” “→” to find ‘save’ word to save information

DEPARTMENT

1. Long press the System Set key till a beep prompts out
2. Use “←” “→” to select ‘Edit Menu ’
3. Use “←” “→” to select ‘department’ and press ‘enter’ key.
4. Input index number and press ‘enter’ key.
5. LCD displays ‘NAME’ ,please input name ,for example ‘apple’
6. Press ‘enter’ to confirm

GROUP

1. Long press the System Set key till a beep prompts out
2. Use “←” “→” to select ‘Edit Menu ’
3. Use “←” “→” to select ‘group’ and press ‘enter’ key.
4. Input index, for example ,input ‘1’
5. LCD displays ‘NAME’ ,please input name ,for example ‘group 2’
6. Press ‘enter’ to confirm

LCD ADVISE EDIT

1. Long press the System Set key till a beep prompts out
2. Use “←” “→” to select ‘Edit Menu ’
3. Use “←” “→” to select ‘LCD Advvertise Edit’ and press ‘enter’ key.
4. Input index, for example ,input ‘1’

HEAD & TALL EDIT

1. Long press the System Set key till a beep prompts out
2. Use “←” “→” to select ‘Edit Menu ’
3. Use “←” “→” to select ‘Head/Tall Edit’ and press ‘enter’ key.
4. Input index line information one by one
5. Press ‘enter’ to confirm

NUTRIENT FACTS TABLE EDIT

1. Long press the System Set key till a beep prompts out
2. Use “←” “→” to select ‘ Edit Menu ’ and press ‘enter’ key.
3. Input index number---ingredients name---daily usage---ingredients unit
4. Choose? % daily value? 0;: input 1: account
5. Choose ?ingredient other element ?0: no; 1: yes

If you want to check the information of the ingredients, back to the ‘ingredient edit’ item and input the corresponding index number.

NUTRIENT FACTS EDIT

1. Long press the System Set till a beep prompts out
2. Use “←” “→” to select ‘ingredients edit’ and press ‘enter’ key.
3. Input LFCODE---Description---Supply Message---Supply Rate
4. Press ‘enter’ key to confirm

PRINT PLU LFCODE

1. Long press the System Set key till a beep prompts out
2. Use “←” “→” to select ‘PLU Print LFCODE Set’ and press ‘enter’ key.
3. Press Enter key for ‘nutrient facts table edit’ and press ‘enter’ key.
4. ? Start LFCODE?: input start LFCODE
5. ?End LFCODE?: input end LFCODE
6. Press enter to save

12.2.2System set

Hardware set

1) LCD Contrast(0-99)

Press ‘system set’ key ---use “←” “→” to select ‘system set’---hardware set --- ‘LCD contrast’----use

“←” “→” to deduct or add time value---press ‘enter’ to save information.

2) Auto Refurbish Time

Press ‘system set’ key ---hardware set ---use “←” “→”to find ‘auto refurbish time’----LCD refurbish time----input time you want to set----press ‘enter’ to save information

3) DATE

Press ‘system set’ key ---use “←” “→” to select ‘system set’---hardware set --- ‘DATE’----input date in the form of ‘YYMMDD’---press ‘enter’ to save information.

Y: year M: month D: day H: hour m: minute

For example: 1210131230 2012Y10M13D12H30m

4) ALIGN

Press ‘system set’ key for 3 seconds---hardware set --- ‘ALIGN’----use “←” “→” to deduct or add time value---press ‘enter’ to save information.

5) LABEL SELECT(1-32)

Press ‘system set’ key for 3 seconds----- hardware set ----LABEL SELECT (1-32)----input label number (from 1--32---press ‘enter’ to save information.

6) Paper

Press ‘system set’ key for 3 seconds----- hardware set ----paper----choose label type (label, receipt, no rewind, black mark label)---press ‘enter’ to save information.

7) LCD SLEEP TIME

8) Press ‘system set’ key for 3 seconds----- hardware set ---- LCD SLEEP TIME----use “←” “→” change value---press ‘enter’ to save information.

9) Printing speed

Press ‘system set’ key for 3 seconds----- hardware set ----speed----use “←” “→” change speed value(50.55.60.65.70.75)

10) AUTO FEED SET

Press ‘system set’ key for 3 seconds----- hardware set ----AUTO FEED SET----choose feed modes(NORMAL, PRE PRINT,PRE FEED)

11) PRINT TEST PAGE

Press ‘system set’ key for 3 seconds----- hardware set ----PRINT TEST PAGE----choose ‘YES OR NO’

Network Set

- 1 INTERNET PROTOCOL (TCP/IP)
- 2 SERVER IP
- 3 ENABLE NETWORK PRINTING
- 4 Use “←” “→” key to select ENABLE NETWORK PRINTING

And press enter, then use “←” “→”open or close online trace.

Parameter Set

- 1) SOURCE PRICE
- 2) Decimal point in quantity column

- 3) CURRENCY PLACE
- 4) FLOATING VENDER
- 5) ZERO UNIT PRICE PRINT
- 6) ANTI WIND
- 7) Stat Warning
- 8) rebate to 23 department
- 9) PRE TARE
- 10) HANDLE TARE
- 11) None Weight can Print
- 12) PRINT ITEM IN WEIGHT ITEM

Use “←” “→” key to choose the item you want to set and press enter to confirm.

12.2.3 Report

1. Long press the System Set key till a beep prompts out
2. Use “←” “→” to select ‘Report’
3. Press Enter key to confirm;

NOTES: the following is the sequence of menu. When one item is input, press Enter to confirm. The system will shift to another item, and press Enter again to enter it. If no contents are inputted, press ESC to exit.

Notes:

1. promoter report: Input promoter number to print report.
 2. Z DEPT. REPORT
 3. X DEPT. REPORT
 4. Clr Stat
 5. Prn ALL Stat. PLU
 6. Prn Subtot: Press [Enter] to print the label
 7. Stat. mode: Whether to set the system in stat. mode. Use arrow key to select “YES” or “NO”.
 - a) If you choose “YES”, the system will be in stat. mode, when you use the hotkey, the sale subtotal of this key will be printed on label. And if you choose “NO”, you can do hotkey operation as normal.
 8. CLEAR PLU REPORT
 9. Z PLU REPORT
 10. X PLU REPORT
 11. Z GROUP REPORT
 12. X G ROUP REPORT
 13. P---PRN SUBTOT: Press [Enter] to print the label
 14. P---PRN ALL STAT. PLU
 15. Z---Z GROUP REPORT
 16. C---CLR STAT
- 1) Promoter report
Press ‘system set’ key for 3 seconds----report----promoter report----NO.(1-8)----input number (1-8)
 - 4) Stat. mode
Press ‘system set’ key for 3 seconds-----report-----Stat. mode-----NO.(1-8)----choose ‘yes or no’
 - 5) PRN.SUBTOT
Press ‘system set’ key for 3 seconds-----report-----PRN. SUBTOT
 - 6) PRN ALL STAT.PLU
Press ‘system set’ key for 3 seconds-----report-----PRN ALL STAT. PLU
 - 7) Z GROUP REPORT
Press ‘system set’ key for 3 seconds-----z group report
 - 8) Clr Stat
Press ‘system set’ key for 3 seconds-----Clr Stat (this operation will clear all sale records)

12.3 Function Lock

PLU edit, Discount Program and tare functions can be locked by password and password of each function is independent and changeable. Password is set by background PC server and downloaded to every scale.

Operation on the label scale is as followings:

Note: Once you turn on the locked function, this function will be valid until the scale is warmly closed.

Turn on the locked function	1. Turn on the scale.
	2. Select the desired function key. Press PLU key for two second to enter PLU editing state, the system prompts to input password, then input the safe password which is set by background PC server. Press System Set key for one second to enter program setting state, the system prompts to input password, then input the safe password which is set by background PC server. Press Tare key for one second to enter tare state, the system prompts to input password, then input the safe password which is set by background PC server. Press Change Price key for one second to enter change price state, the system prompts to input password, then input the safe password which is set by background PC server.
Lock these functions again.	1. Press On/Off key for two seconds to warmly close the scale.
	2. Press On/Off key to open the scale.

12.4 Lock Scale

You can lock the scale by password, so that other people can't do any operation on the scale.

Lock scale as the following method:

Lock the scale	1. Press SHIFT and then Password key until the word "PASSW" appears on the LCD display.
	2. Input the eight-digit password by numeric keyboard.
	3. Press SHIFT and then Password key and after hearing a "beep" sound to show the password has been set.
Turn on the lock casually	1. Turn on the scale.
	2. The LCD display "PASSW".
	3. Input the eight-digit password, then press SHIFT , then Password key to turn on the lock.
Turn on the lock timelessly	1. Turn on the scale.
	2. Press CL key.
	3. Press SHIFT , then Password key for two seconds until the word "PASSW" appears on the LCD display.
	4. Input the eight-digit password, then press SHIFT , then Password key to turn on the lock.

13 COMMUNICATION SETUP

13.1 Wired Ethernet Setup

Barcode scale, Ethernet contains PC and several scales, every scale connect Ethernet via HUB. As follows:

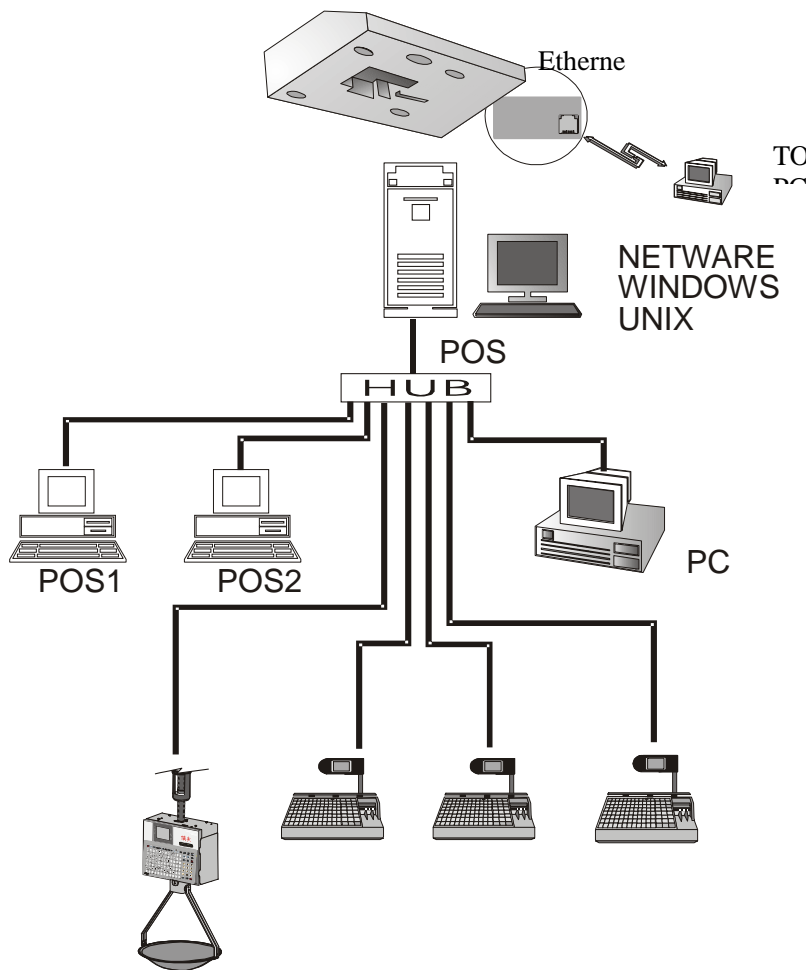

Ethernet IP Address set:

1. The division of the Ethernet IP address is by professional person, and the IP address of workstation is the same as the scales (the first nine digits are the same). Any workstation under the same segment install link32 can make communication test to the scales under the same segment.
2. Refers to "System Set"---'IP Address Input' from the attached disk to input the IP to the scales.

Communication Line Setup Requirements:

1. Consider the installation of the communication line setup when install label scale. Internet installation had better be done during install local pipeline. Communication line use 8core Ethernet communication cable to make sure the wire rod is under low impedance.
2. The installation of the line should avoid interference source, such as air compressor and high-power electricity appliance, and avoid to install alongside the high current power line, and use metal sheath to shield.

3. The sheath is need to protect the communication line, PVC or metal sheath are available, use metal sheath under strong electromagnetic interference and connect the metal to the floor to shield.
4. The place for barcode scale should be away from humidity environment, junction box should pay attention to dampproof.
5. The whole length of the wire should not beyond 100m, use standard A line connect way or B line connect way, one system use one connection method.

13.2 Wireless Ethernet Setup

If you purchase the wireless scale, you can use wireless Ethernet setup method to set up the communication network. Use the transmit and receipt equipment of wireless Ethernet from our company can make the barcode scale connect with wireless Ethernet.



13.3 Making procedure of connector

(1) Select a connector wire (8 pin) by length of L.

(2) Put A end of the connector wire at the edge of blade of pliers horizontally (note: point against the baffle to ensure 12mm peeling length), press the pliers and pull out the wire and the peeling length is about 12mm.

1. Connection order:

green/white, green, orange/white, blue, blue/white

orange, brown/white, white.

2. line Connection order:

orange/white, orange, green/white, blue, blue/white,

green, brown/white, white.

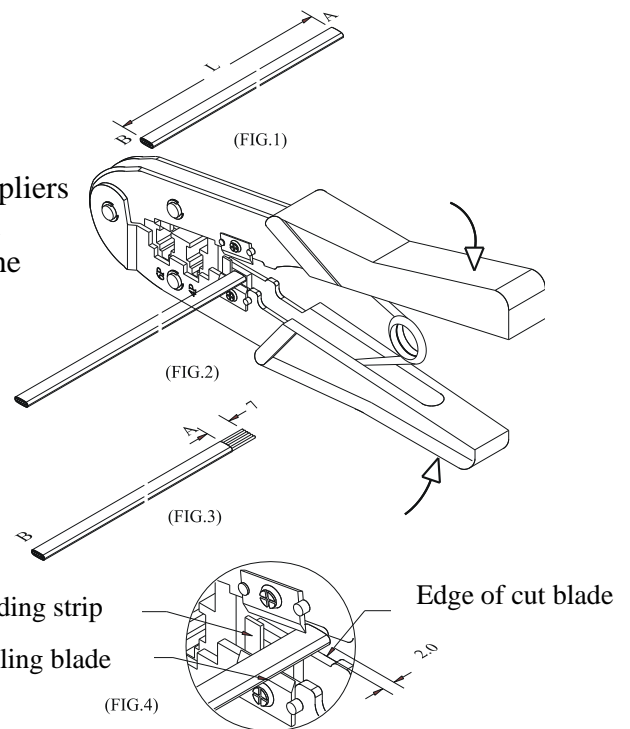

(3) Plug peeling end (A) into 8 PIN PHONE connector as either Connection order above.

Make sure to plug to the end.

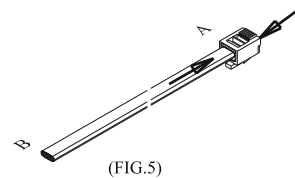

(4) Plug wire connector with 8 pin into the position with logo 8P of pliers gently, then press the pliers forcefully.

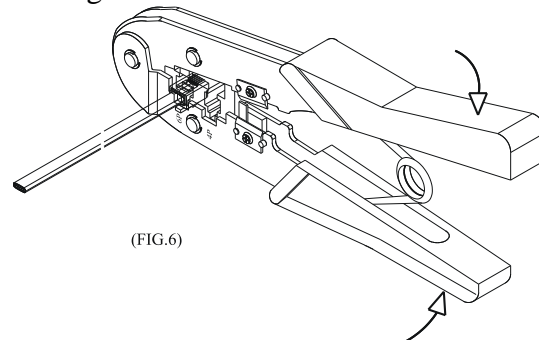

(5) When process end B of connecting wire, don't twist wire and keep the wire with same color in the same position.

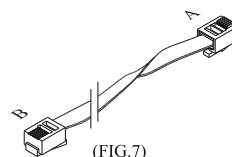

14 Troubleshooting

The scale breaks down:

1. There is no sound and no display but backlight when power is on.

Reason: Electric sparkle caused by power plugging in and pulling out destroys the ROM program in the main board.

Treatment: Change main board, reset sequence number and download all records.

2. There is no sound and displaying 'UPDATE' when power is on.

Reason: The same as the above.

Treatment: Download POS program to the scale again.

3. Buzzer sounds continuously and the displaying characters bounce.

Reason: The same as the above.

Treatment: The same as the above.

Question about print:

1. Paper location is normal but the printed out label is blank.

Reason: Label type sets error. It is required label type printed out by the scale should be consistent with which downloaded from PC. Otherwise the label printed out will be blank.

Treatment: a. Adjust the scale according to the following sequence.

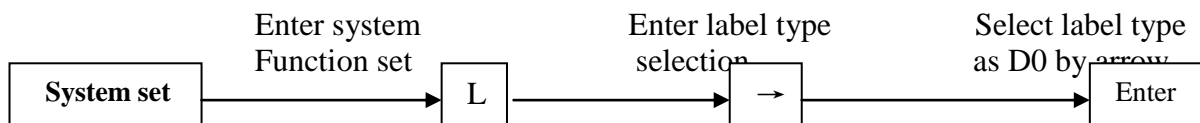

b. Also we can adjust the software with PC. Open link 64, input serial number of the scale, run command function set and download this function set to the scale.

2. Printer spits out half paper or one and a half papers and paper locates abnormally.

Reason: a. Paper type sensor set error

b. Printer back photoelectric group is in wrong direction or covered by dust.

c. Photoelectric board is bad.

d. Photoelectric group of back photoelectric is bad.

Treatment: a. According to the following sequence, adjust the scale.

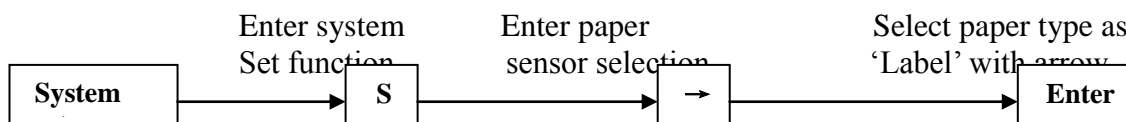

We can also make software adjustment on computer. Open 'Link32', set paper type as 'Label' in function set; download the set to the scale.

b. Check whether the back photoelectric group is gradient or covered by dust.

c. If it can't be resolved yet it is necessary to exchange back photoelectric group, which had better be handled by the professional of our company.

3. Label out of printer is obscure and not dark enough.

Reason: a. Printer header is not put well.

b. Hot sensor head is dirty.

c. It is necessary to carry on voltage learning.

Treatment: a. Place printer header in suitable position

b. Clean the thermal printer with soft tissue or swab (no hard stuff, like knife), if not clean enough, please clean it with fine dried cloth dipped in little alcohol in shutdown mode.

4. Label printed out is half clear and half blur even blank.

Reason: a. Printer header is not put well.

b. Hot sensor header is dirty.

c. Printer header is distorted.

Treatment: a. Place printer header in suitable position.

b. Clean the thermal printer with soft tissue or swab (no hard stuff, like knife), if not clean enough, please clean it with fine dried cloth dipped in little alcohol in shutdown mode. (Please refer to the demonstration below.)

c. If this problem can't be resolved yet it is necessary to change the printer. The bad printer had better to be handled by professional of our company.

➤ Demonstration for cleaning the thermal printer head:

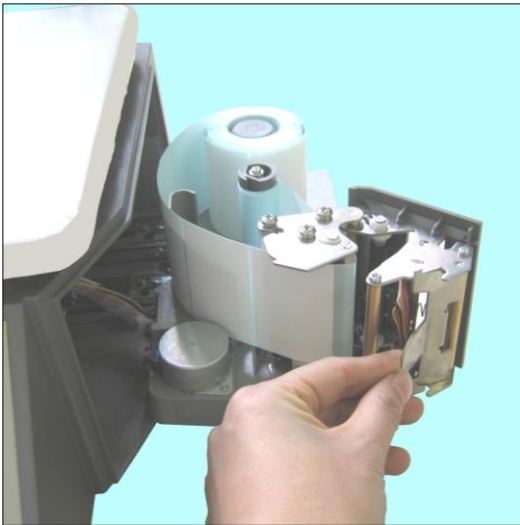

① Open the thermal printer head

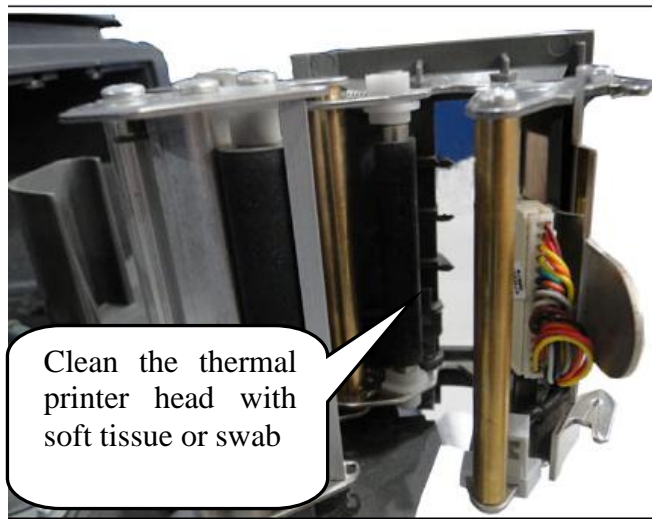

② Clean the thermal printer head.

5. There is strange letter on the label.

Reason: LFZK has not been downloaded.

Treatment: Download LFZK again.

Questions about keyboard:

1. Display is normal but keyboard sounds continuously.

Reason: There is a short circuit in keyboard.

Treatment: change keyboard circuit.

2. Key doesn't sound.

Reason: a. Key wire is not inserted well.

b. Electric rubber of key press circuit board is not installed well.

c. The replaced kit is bad.

Treatment: a. Check key wire and insert it again.

b. Remove the electric rubber of key press and another location with rubber strip install again.

c. If the problem can't be resolved yet, the selected kit is bad.

Questions about weighing:

1. The scale can't weigh correctly.

Reason: a. Rubber pad, which sustains the scale pan, touched the shell (upper cover).
b. Humidity or component aging or area difference makes the scale weigh incorrectly.
c. Sensor is damaged by over loading.

Treatment: a. Check whether the upper covers are buckled well. If they still knock each other, install sensor sustainer again.
b. Study zero weight and full weight again. If it is still no use, change main board, OP board or even the sensor.
c. Change sensor and sustainer.

Note: OP board and sensor should be returned to our company in principal if they can't be used.

2. Zero state is not stable.

Reason: a. It is affected by environment such as vibration, or magnetic field interference, or wind.
b. Weighing circuit is affected with damp.

Treatment: a. Remove interference.
b. Change main board.
c. If the problem can't be resolved. Return the whole scale to our company to repair.

3. The scale can't weigh.

Reason: Main board or OP board or sensor is bad.

Treatment: a. Change main board.
b. Check whether OP board is abnormal. Return the whole scale to our company.

Questions about communication:

1. The scale can't communicate.

Reason: a. Communication port set error.
b. Serial number of the scale has not been set.
c. Connecting head is not used correctly or Netware wire is obstructed.
d. There is some wrong with power board or main board.

Treatment: a. Confirm the correct communication port.
b. Confirm number set in Link32 is consistent with the number in the scale.
c. Confirm the Netware wire is smooth and communication connecting header is used correctly. There are two types of communication port RS-232 which uses 9-pin or 25-pin connecting port attached with the scale and RS-422 which uses RST-11A connecting head.
d. If the above are right, detect whether main board or power board is wrong and change the wrong main board or power board.

2. Downloading is stopped at 1/N (n represents some number) and computer shows message "communicate error!"

Reason: Main board is error, which may be caused by chip damage.

Treatment: Change main board or chip (ROM).

Question about display:

Display can't show all characters or even a character.

Reason: a. Display pole has not been installed well, which causes the display and the machine in bad contact.
b. Water flows into the base seat of display pole which makes link board short-circuit or rotten.
c. Display is damaged.

Treatment: a. Install display pole and fix the bolt.
b. Change link board or display pole.
c. Change display pole.

Other question:

Roll paper can't be driven by print.

Reason: maybe roll paper doesn't get well along with rotating axis. Or there is some matter with

rotating axis.

Reason: Maybe roll paper doesn't get well along with rotating axis. Or there is some matter with rotating axis.

Treatment: Install the printer again which had better be processed by our company.

15 APPENDIX

15.1 Appendix 1: Barcode Coding List

Barcode type	Department	Commodity number	Total price	Weight	Checksum
00~09: Ean13 code, the front two codes represent department code:					
00	DD (2)	IIIIIIII (10)	X	X	C
01	DD (2)	IIIII (6)	PPPP (4)	X	C
02	DD (2)	IIII (5)	PPPPP (5)	X	C
03	DD (2)	IIII (4)	PPPPP (6)	X	C
04	DD (2)	III (3)	PPPPPP (7)	X	C
05	DD (2)	IIIII (6)	X	Q.QQQ (4)	C
06	DD (2)	IIIII (6)	X	QQ.QQ (4)	C
07	DD (2)	IIII (5)	X	QQ.QQQ (5)	C
08	DD (2)	IIII (5)	X	QQQQ.Q (5)	C
09	DD (2)	IIII (5)	X	QQQQQ (5)	C
10~19: Ean13code, the front two codes represent fixed code:					
10	20(2)	IIIIIIII (10)	X	X	C
11	21(2)	IIIII (6)	PPPP (4)	X	C
12	22(2)	IIII (5)	PPPPP (5)	X	C
13	23(2)	IIII (4)	PPPPP (6)	X	C
14	24(2)	III (3)	PPPPPP (7)	X	C
15	25(2)	IIIII (6)	X	Q.QQQ (4)	C
16	26(2)	IIIII (6)	X	QQ.QQ (4)	C
17	27(2)	IIII (5)	X	QQ.QQQ (5)	C
18	28(2)	IIII (5)	X	QQQQ.Q (5)	C
19	29(2)	IIII (5)	X	QQQQQ (5)	C
20: no print barcode					
21~29: Ean13 code, the front one code represents department code:					
21	D (1)	IIIIII (7)	PPPP (4)	X	C
22	D (1)	IIIII (6)	PPPPP (5)	X	C
23	D (1)	IIII (5)	PPPPP (6)	X	C
24	D (1)	IIII (4)	PPPPPP (7)	X	C
25	D (1)	IIIIII (7)	X	Q.QQQ (4)	C
26	D (1)	IIIIII (7)	X	QQ.QQ (4)	C
27	D (1)	IIIII (6)	X	QQ.QQQ (5)	C
28	D (1)	IIIII (6)	X	QQQQ.Q (5)	C
29	D (1)	IIIII (6)	X	QQQQQ (5)	C
30~35,40~45: 18code, the front one code represents department code					
30&33	D (1)	IIIII (6)	PPPPP (5)	QQ.QQQ (5)	C
31&34	D (1)	IIIII (6)	PPPPP (5)	QQQQ.Q (5)	C
32&35	D (1)	IIIII (6)	PPPPP (5)	QQQQQ (5)	C
Barcode type	Department	Commodity number	Price	Weight	Checksum

40~45: Ean18 code, the front one code represents department code					
40&43	D(1)	IIIII(6)	UUUUU(5)	WW. WWW(5)	C
41&44	D(1)	IIIII(6)	UUUUU (5)	WWW.W(5)	C
42&45	D(1)	IIIII(6)	UUUUU (5)	WWW.W(5)	C
50~52: 8 code					
50	X	IIIII (7)	X	X	C
51	D (1)	IIIII (6)	X	X	C
52	DD (2)	IIIII (5)	X	X	C
53	X	IIIIII(8)	X	X	X
54	D(1)	IIIIII(7)	X	X	X
55	DD(2)	IIIII(6)	X	X	X
36-38: 18code, the front one code represents department code, which is particular for the batch management of live commodity.					
36	D (1)	LLLLLL (6)	III (4)	RR (2)	QQ.QQQ (5)
37	D (1)	LLLLLL (6)	III (4)	RR (2)	QQQQ.Q (5)
38	D (1)	LLLLLL (6)	III (4)	RR (2)	QQQQQ (5)

Bar code type	Department	Art. No	Quantity/weight	Total/Unit price	Check sum
79~85, 87: 18 code					
79	DD	IIIII(6)	WW.WWW	PPPPP	X
80	D	IIIII(6)	WW.WWW	PPPPP	C
81	D	IIIII(6)	WWW.W	PPPPP	C
82	D	IIIII(6)	WWW.W	PPPPP	C
83	D	IIIII(6)	WW.WWW	UUU.UU	C
84	D	IIIII(6)	WWW.W	UUU.UU	C
85	D	IIIII(6)	WWW.W	UUU.UU	C
87	DD	IIIII(5)	WW.WWW	PPPPP	C

Bar code type	Department	Art. No	Total price	Quantity/weight	Unit price	Check sum
90~95: 18 code, the former two codes print department code						
90	DD(2)	IIIII(6)		WW.WWW	UU.UU(4)	C
91	DD(2)	IIIII(6)		WWW.W	UU.UU(4)	C
92	DD(2)	IIIII(6)		WWW.W	UU.UU(4)	C
93	D(1)	IIIII(6)	PPPPP(5)		UUU.UU(5)	C
94	DD(2)	IIIII(5)	PPPPP(5)	WW.WWW		C
95	DD(2)	IIIII(6)		WWW.W	UU.UU(4)	C
Bar code type	Department	Art. No	Quantity/weight	Total price	Unit price	Check sum
96	DD(2)	IIIII(6)	WWW	PPPPP(5)		C
Bar code type	Department	Art. No	Total price	Quantity/weight	Unit price	Check sum
97	DD(2)	IIII(4)	PPPPP(6)	WW.WWW		C
Bar code type	Department	Art. No	Quantity/weight	Total price	Unit price	Check sum
98	DD(2)	IIIII(5)	UUUUU(5)	WW.WWW		C

Meaning of characters in the above list:

C: CHECKSUM D: Department code 2: Fixed number I: commodity number L: Live code

P: price R: discount Q: weight X: no this item

Notes:

1. Ean 13= DEPARTMENT+CODE+[TOTAL PRICE]+[WEIGHT]+C

Items with [] mean no this item in some coding system.

2. Usually Ean13 adopts 2 or 22 as its price barcode type while 7 or 77 as its weight barcode type.

3. CHECKSUM is calculated by the scale automatically and it is not necessary for user to input in PLU manager.
4. The difference between 30-32 and 33-35 is the method to calculate checksum.
5. The difference between 40-45 and 30-35 is that the price in 30-35 is total price while in 40-45 is unit price.
6. 36-38 is barcode type, which can be accessed by live batch management. Commodity batch number takes up commodity number column and commodity number takes up live code column.

