

# **BARCODE LABEL SCALE**

## **QUICK START**

**Pinnacle Technology Corp.**

## Important Safety Information

1. Please read these safety instructions carefully.
2. For safety of SD card and USB data, when pulling out SD or USB, please firstly press power button slightly for standby mode and then pull it out .
3. Keep this user manual for later reference.
4. Before turning on the machine, please make sure that the electric power meets the requirements, (such as the electrical pressure and frequency), and that your electrical outlet is really connected to the ground.
5. This product meets the relative requirements of the national standard IEC 60950:2001 “Safety of information technical equipment”.
6. Thunder can hurt this product and even your personal safety, so please pull out the network cable, electrical cable and other conductor connecting external attachment in thunder days.
7. The non-experts or non-authorized people please don't open the machine shell.
8. Please don't spatter any sundries or liquid into the machine; please don't stuff anything inside this product, otherwise it may cause short circuit and therefore may lead to fire or get an electric shock.
9. Please do not plug or unplug with wet hand.
10. Make sure the switch is off when plug or unplug the power.
11. Incorrectly changing the lithium battery on the main board and the UPS lithium battery in the machine may cause a blast, so please make sure installing and changing the lithium batteries under the instruction of the expert service personnel.
12. Please be sure not to change the battery with a wrong type one, otherwise there is danger of explosion. Be sure to deal with used battery with the way of dealing with waste battery.
13. Please charge the lithium battery about every three Months, in case it would discharge over time and lead to useless.
14. Please lay this product packed in the 10-40°C environment for at least 2 hours before turning on if it was stored in less than 10°C temperature environment during the transportation, so as to avoid the damage on the product due to a big change of environmental temperature.
15. For PLUGGABLE EQUIPMENT, the socket-outlet shall be installed near the equipment and shall be easily accessible.
16. Please don't throw anything on this product or hit against it.
17. Please do not disconnect the line cord while its working, if not the product would be broken.
18. Please be sure use our line cord only.
19. If there is abnormal noisy, burnt smell or smoke given out from the product, please cut off the power and disconnect the plug immediately. And contact the service center. Or there is danger of electric shock or fire.
20. Please do not allow children to climb up on the product, in case the product drops and hurt them.
21. Please do not disconnect any parts or lines except USB equipment while using.
22. Switch off the product if you will not use it in a long time.

We look forward to receive your valuable feedback after using our products , any suggestion (especially the suggestion related to strengthening utilization convenience of products). Contact us with the following ways and we will give a gift in return.

Contact Way:

Telephone: 0592-5710085

Email: PT@aclas.com

Website: [www.aclas.tw](http://www.aclas.tw) (Homepage >> Service and Support >> Feedback >> Satisfaction Survey)

# CONTENT

1	Installation .....	1
1.1	Display Pole Installation.....	1
1.2	Paper Installation .....	2
1.2.1	Label Paper Installation .....	2
1.2.2	Lineless Paper Installation.....	4
2	Power on/off .....	5
3	PLU and Label Edition .....	5
3.1	Link Scale to PC .....	5
3.2	PLU Edition .....	7
3.3	Label Edition .....	11
4	Hotkey .....	12
4.1	Hotkey Edition.....	12
4.2	Hotkey Sheet Installation.....	14
5	Sales Operation.....	15
5.1	Calculate by Weight.....	15
5.2	Calculate by Piece.....	16
5.3	Tare Operation .....	16
5.4	Discount.....	17
5.5	Name Input Function .....	17
5.6	Change Price.....	17
6	Package Type .....	18
6.1	Package by Fixed Weight .....	18
6.2	Package by Fixed Price.....	18
6.3	Gift Baskets Function .....	18
7	Basic settings .....	19
8	Appendix: Barcode Coding List.....	20

# 1 Installation

## 1.1 Display Pole Installation

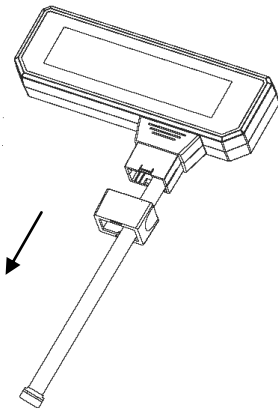

1. Take out the fix

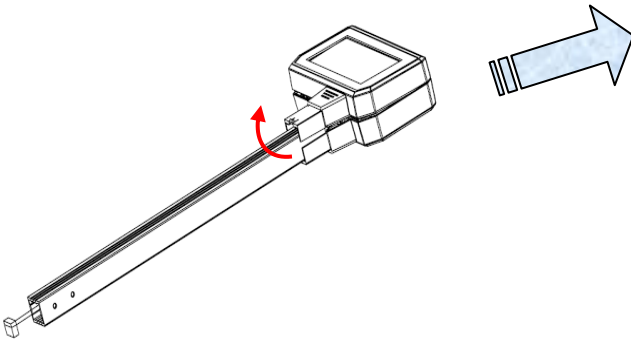

2. Open the LCD cover 3° ~5°, and Mount the display pole.

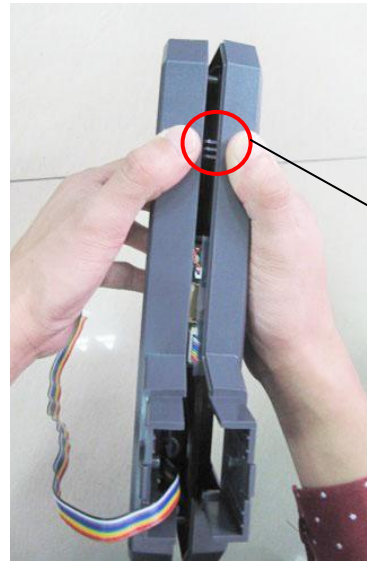

Internal dogging location

**Warning when opens cover:**

The dogging is located on the light-colored side of the display, far from the display pole. Open the cover with hands here.

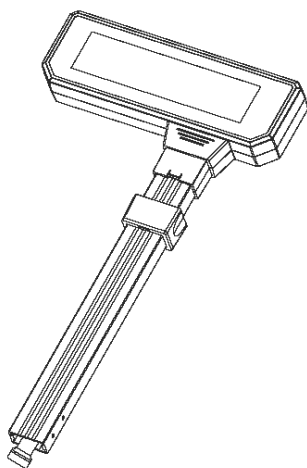

3. Cover the LCD, then put on fix set like the picture shows.

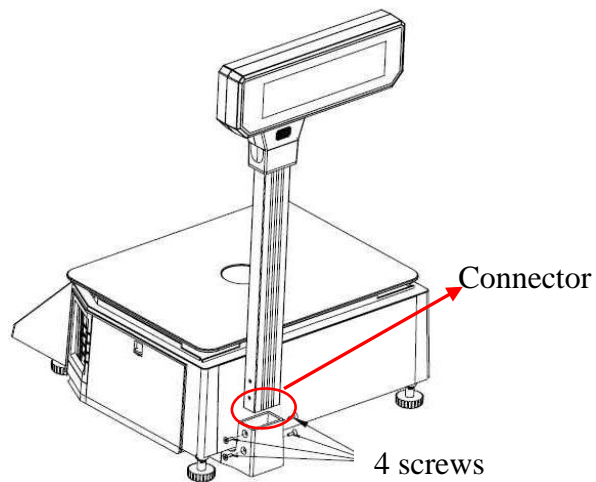

4. Put on fix set .Connect the line, and fix the 4 screws.

## 1.2 Paper Installation

### 1.2.1 Label Paper Installation

**Notice: please take the conveying protection bolt down, when you load the paper for the first time.**

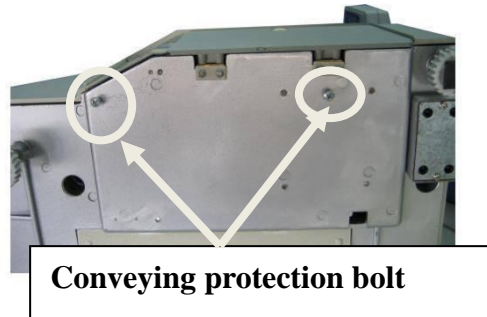

(1) Open the side cover

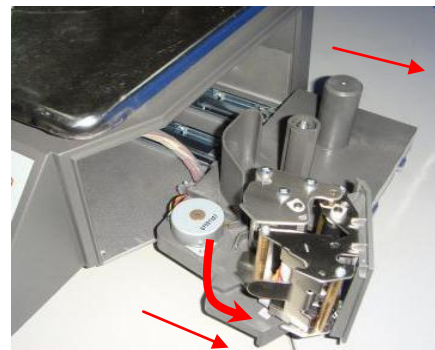

(2) Take out the printer, and open the turnable printing assembly



(3) Tear off the first several labels.

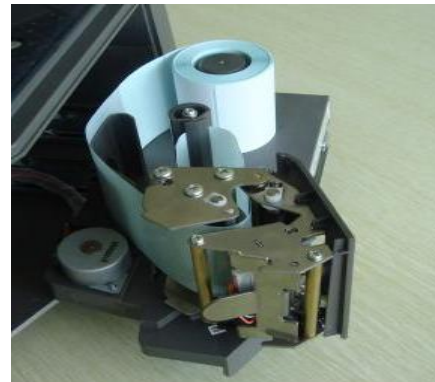

(4) Insert the release paper to the rewriter

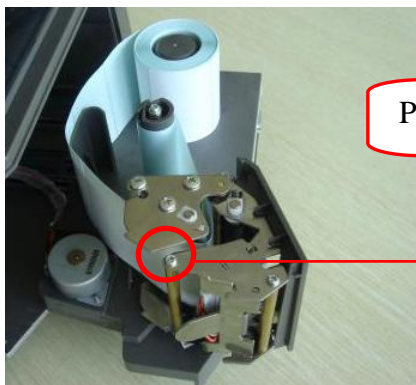

Paper-fixing-block

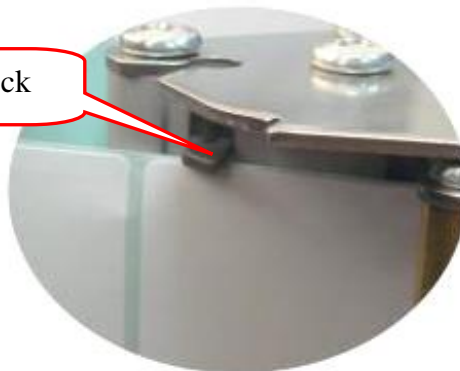

(5) Roll the release paper in the rewriter axis, and adjust the paper-fixing-block to fix the roll paper.



(6) Close the turnable printing assembly.



(7) Close the side cover

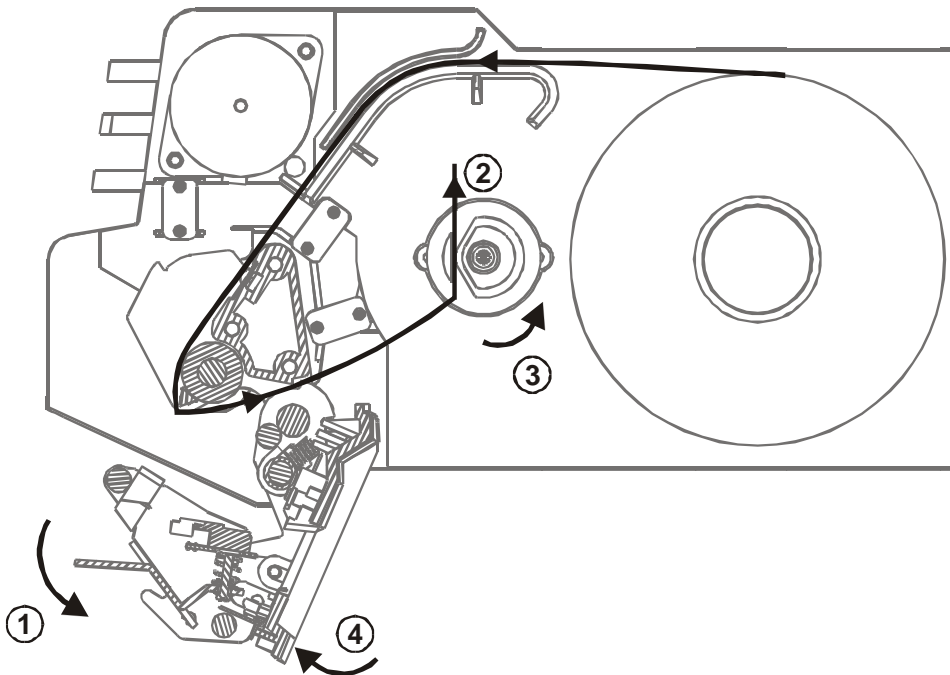

1. Turn the bar outwards, open the turnable printing assembly in the direction shown as the arrow ① shows.
2. Please rip off the first several labels, load paper in the direction shown as the arrow ② shows, roll the release paper in the rewriter axis as the direction of arrow ③ shows.
3. Push the turnable printing assembly to the right position in the direction shown as the arrow ④ shows.
4. When every five-paper roll is used up, or the labels print unclearly, please clean the printing head by using cotton dipping cleaning oil or alcohol.

**Note:** Press the “FEED” key for 2 seconds; the scale will adjust the paper’s position automatically; you can also press it to adjust the paper minutely.



## 1.2.2 Lineless Paper Installation

**Note:** The lineless paper printing module is different from the receipt and label printing module. If customers bought was the receipt or label printing module, but now want to replace it to the lineless paper module, please contact the service department.

Please pre-set the related items when you print lineless paper.

1. Press “System set” for seconds to enter the related setting, and then press “←” and “→” keys till the LCD display “Gap paper” and choose “Yes”, and then press the key “Print/Enter” to confirm.
2. Press “System set” for seconds to enter the related setting, and then press “←” and “→” keys till the LCD display “paper type”, please choose “black label”, and then press the key “Print/Enter” to confirm.

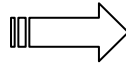
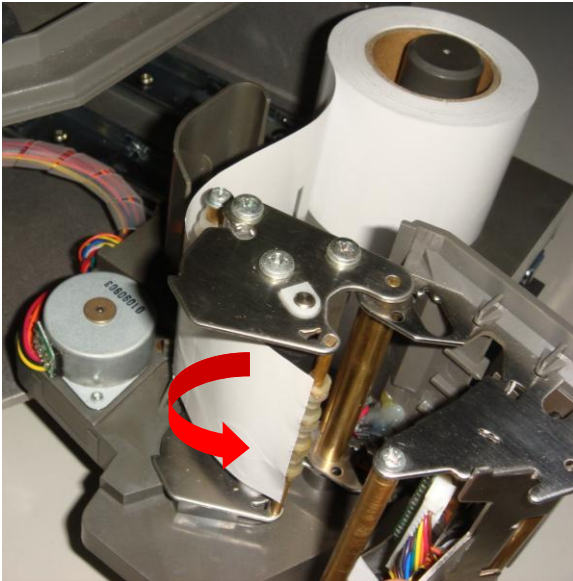

- 1) Open the side cover of printer and the print head. And then wind the paper bypass filter plate like the arrow shows, and lead the lineless paper to the paper exit.



- 2) Close the rotatable printing assembly



- 3) Close the side cover

## 2 Power on/off

### Power on:

Press the power switch  to turn on the scale. At the first ten seconds after you turn on the scale, the LCD displays from “9” to “0” to enter self-testing. Then the scale will enter into sales mode.

**Note: Please make sure there is nothing on the pan and do not press any key when the scale is initializing.**

### Soft-on/off:

The key  is a soft-on/off function. Press this key and hold it for 2 seconds to turn off the scale.

**Suggestion: please use  key to turn off the scale, and do not pull out the power plug directly, especially if the scale is under the condition of connecting with network or downloading data.**

## 3 PLU and Label Edition

### 3.1 Link Scale to PC

1. Connect scale to PC: via Ethernet Port.
2. Open the program of Link65.

Open the Program in the disk attached , double click “AclasActiveSync\_PC”, and input the default user name “admin” (Letters are not case-sensitive)and default password “123”, then click “Enter” to enter the program.

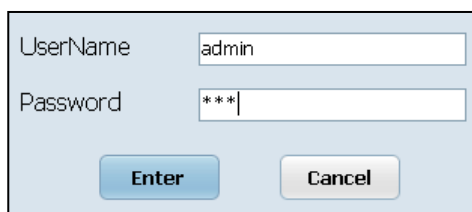

A login dialog box with a light blue background. It contains two text input fields: 'UserName' with 'admin' entered and 'Password' with '\*\*\*' entered. Below the fields are two buttons: 'Enter' and 'Cancel'.

3. Communication test.

Click “File”---“Device Manager” on the interface of the program.

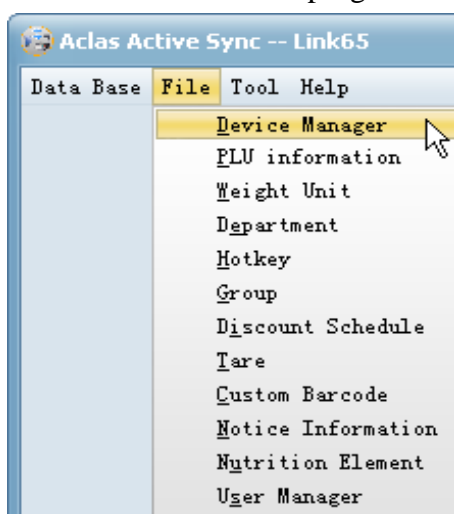

If the state shows “Offline”, it means the scale doesn’t connect with PC, communication between the



scale and PC fail. Please replug the Ethernet cable again. If the IP address of the scale shows in the state column is wrong, please click the “Add” icon  on the tool bar (or right click the column and click “Add” to add new address).

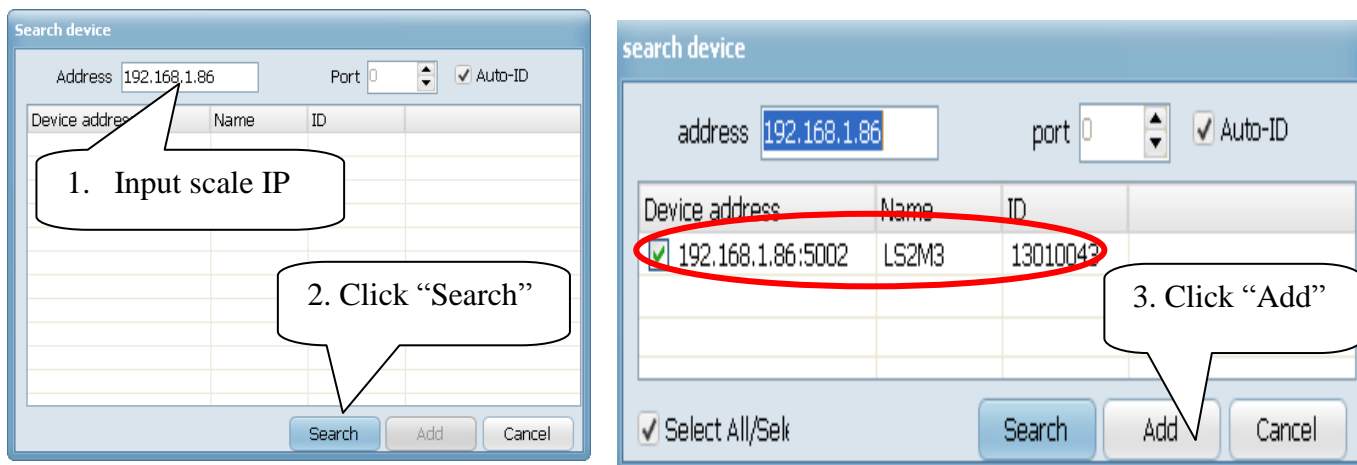

Note: PC and device should be on the same network to realize communication. For example, if PC and device are on the network “1”, you should input “192.168.1.255” on the address. Then, click “search” icon, you can find all IP address that connected to PC. When on the network “2”, input “192.168.2.255” and then click “search” icon.

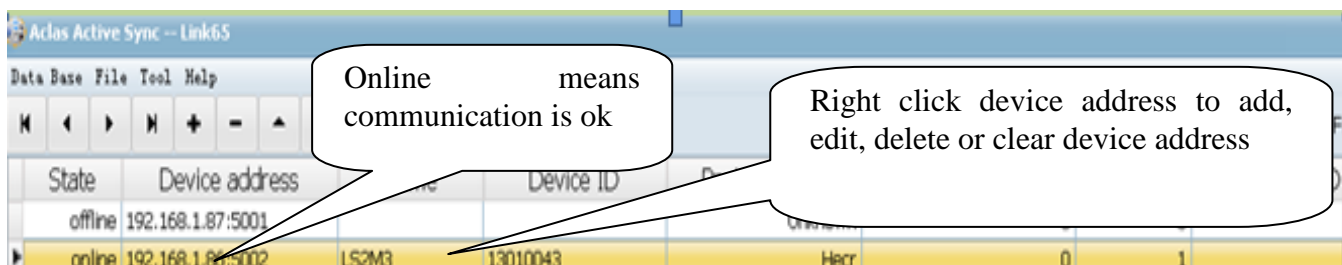

The IP address shows online means communication is ok, you can begin to download and upload data between scale and PC. Select “online” state, you can check the state, address, hotkey, etc. And, you can check and save the parameter of the device, check profile and save the parameter to the PC. Right click device address to add, edit, delete or clear device address.



## 3.2 PLU Edition

You can click icon “Add”  on the toolbar to edit PLU information, and click “Save” icon  to save the operation;

If there are PLU information that has been already edited on PC, you can import it to Link65 program and download to scale. Click “Tool”---“Import Data”---“PLU information”, and then choose the PLU document on the pop window, then click “Open” to execute. After importing PLU, click “Complete” to close the state window. And click “Sync Data” to download PLU information to scale.

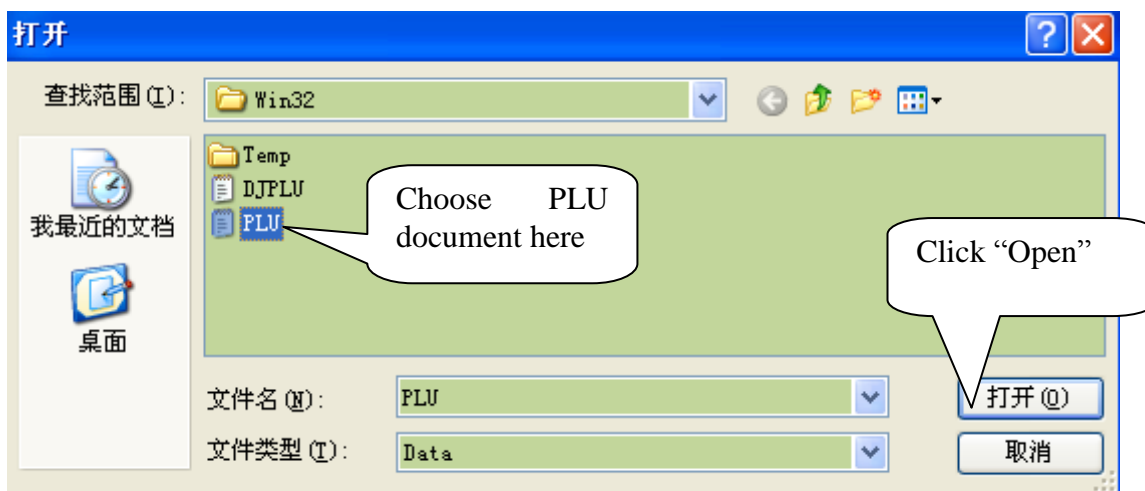
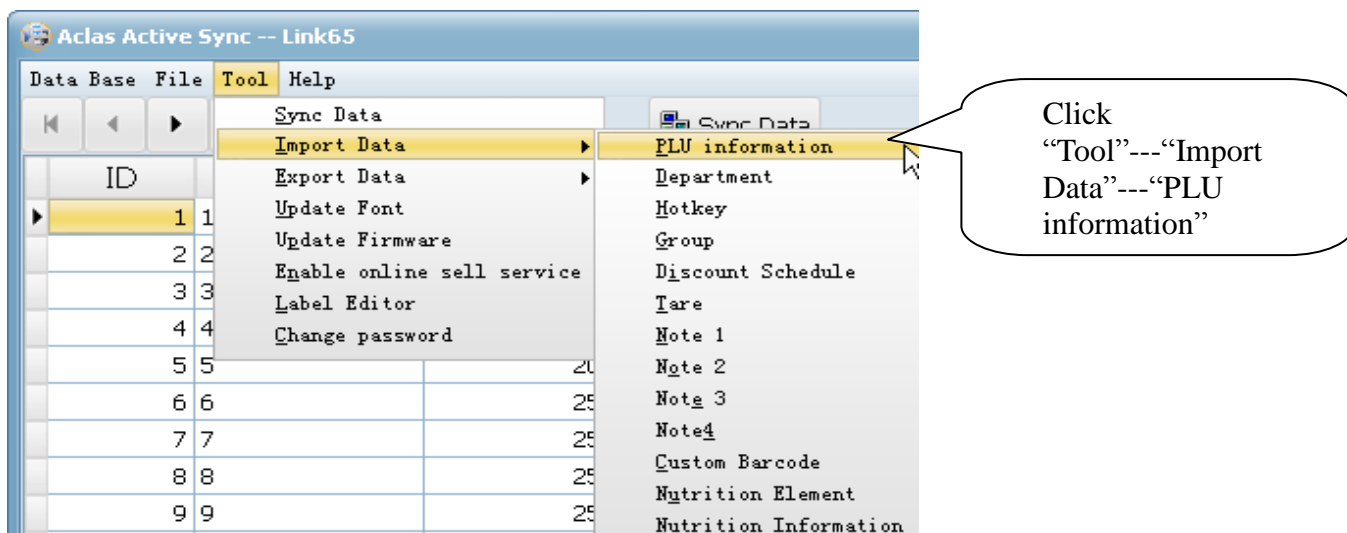

Click the done button after finishing importing data.

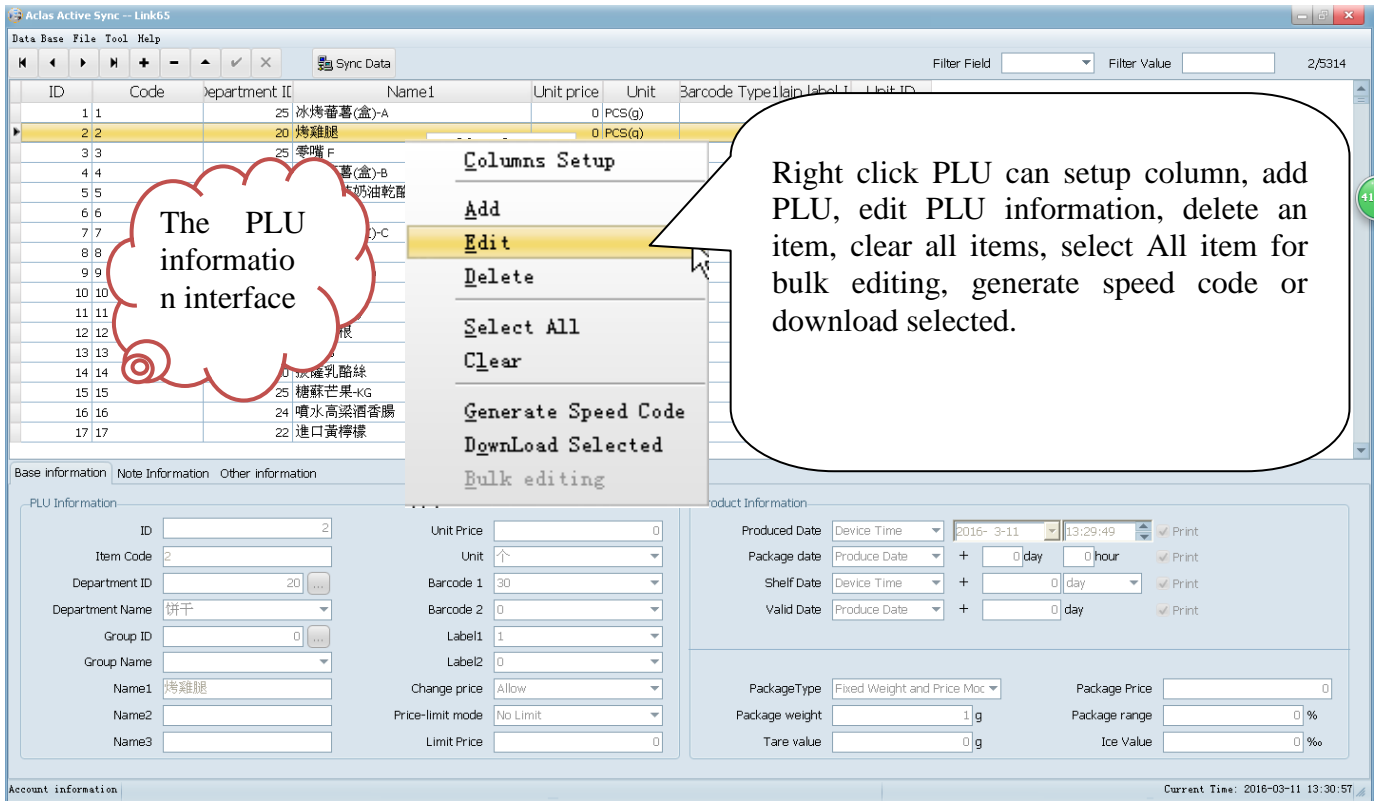

Choose an item and double click to edit (or choose an item and click “Edit” icon ▲ for edition).

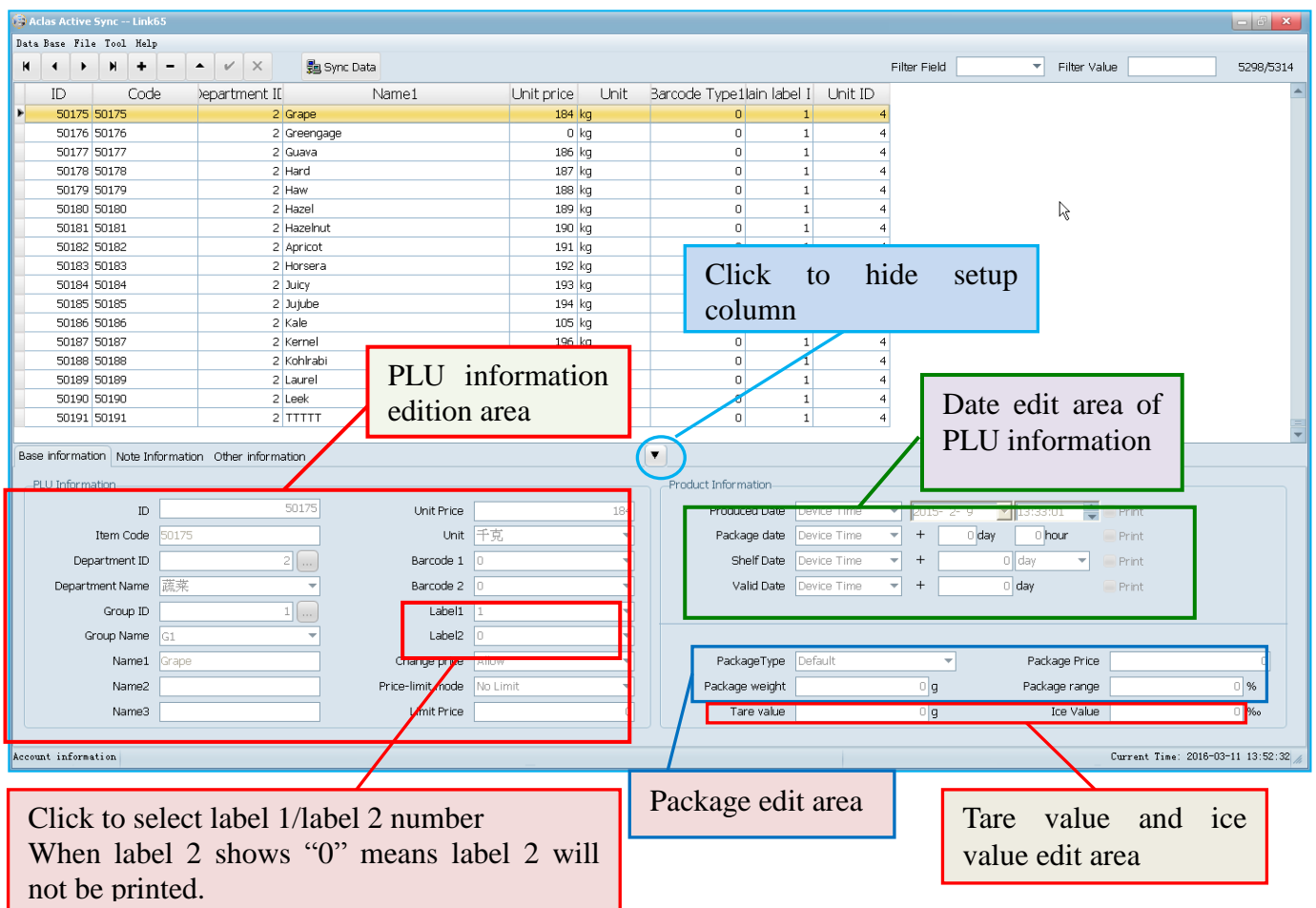

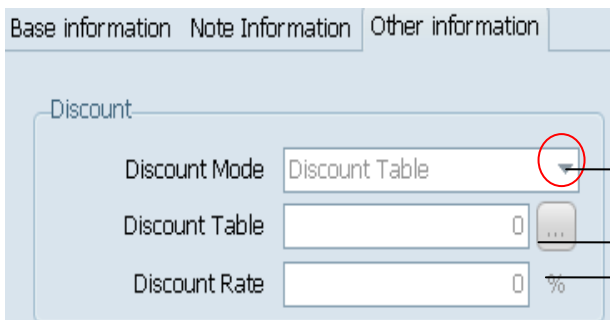
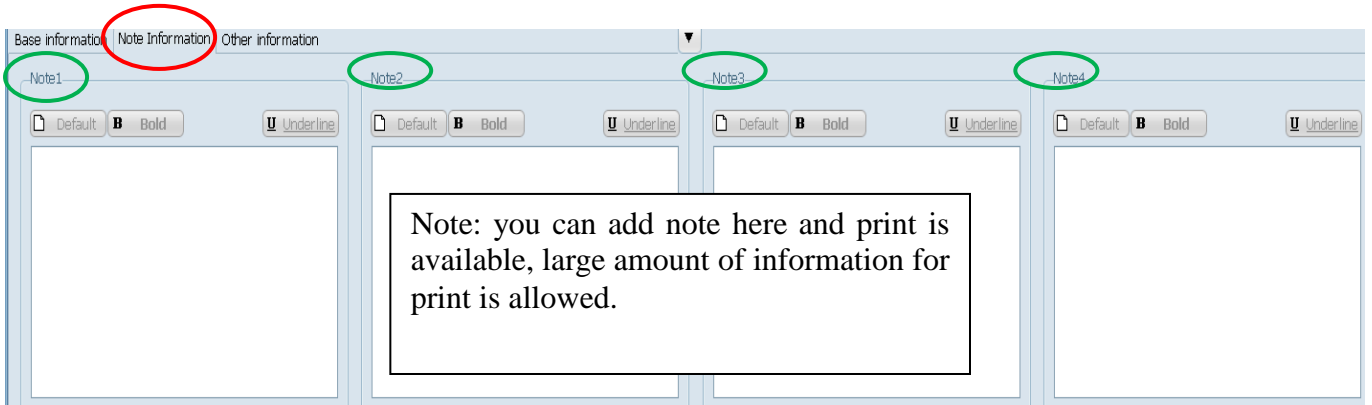

- Click here to select "Discount Mode" or "Discount Table"
- Click here to select Discount Table
- Click here to select Discount Rate

Note: the edition of discount can be seen in PC Management chapter 6.4 Discount schedule edition.

## Note: Tool bar introduction



A:  The first record;

B:  Prior record;

C:  Next record;

D:  Last record;

E:  Insert record;

F:  Delete record;

G:  Edit record;

H:  Save edition;

I:  Cancel edition;

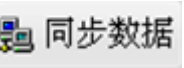
J:  同步数据 Synchronize data: download data from program to scale.

K:  Refresh data

### 3.3 Label Edition

**Warning:** when edit custom label, please refer to the default label template, in case print too much content on a label so as to shorten the lifetime of the printer header.

Edit custom label according to the following steps:

Open the attached program “AclasActiveSync\_PC”, and click “Tool”---“Label Editor” to open the label editor for label edition.

**1. Open** (Callout pointing to the File menu)

**2. In this interface, input Label No.(1-32), width and height (suggest 56\*40), Label version (M3), click “ok” after setting** (Callout pointing to the Setting dialog box)

**3. Choose barcode type in this field → drag the mouse on the right blank label → select each barcode type for edition note, name, shape, font etc.** (Callout pointing to the Barcode field in the left sidebar)

**4. Click “Save” after editing** (Callout pointing to the Save icon in the toolbar)

**5. Click this to download label to scale** (Callout pointing to the Download icon in the toolbar)

**6. Choose scale IP where the label download** (Callout pointing to the Communication dialog box)

**7. Click “Execute” to start to download.** (Callout pointing to the Execute button in the Communication dialog box)

Other callouts in the main interface include:
 

- Text → PLU name 1
- Barcode → barcode 1
- Price → Total Price
- Image → Back, Image → Import
- Price → Price
- Weight → Weight
- Other text → Other
- Select any barcode type and you can edit its font, shape, border, name and so on this property field.

Setting dialog box with fields for Label No., Width (56), Height (40), and Label Version (M3). Buttons for OK and Cancel are visible.

Communication dialog box showing a table of devices for selection. The 'Execute' button is highlighted.

Select	Media	Machine No.	IP Address	Port Name
<input checked="" type="checkbox"/>	doUDP	1	192.168.002.211	
<input type="checkbox"/>	doCOM	2		COM1
<input type="checkbox"/>	doUDP	3	192.168.002.234	
<input type="checkbox"/>	doUDP	4	192.168.2.211	

# 4 Hotkey

## 4.1 Hotkey Edition

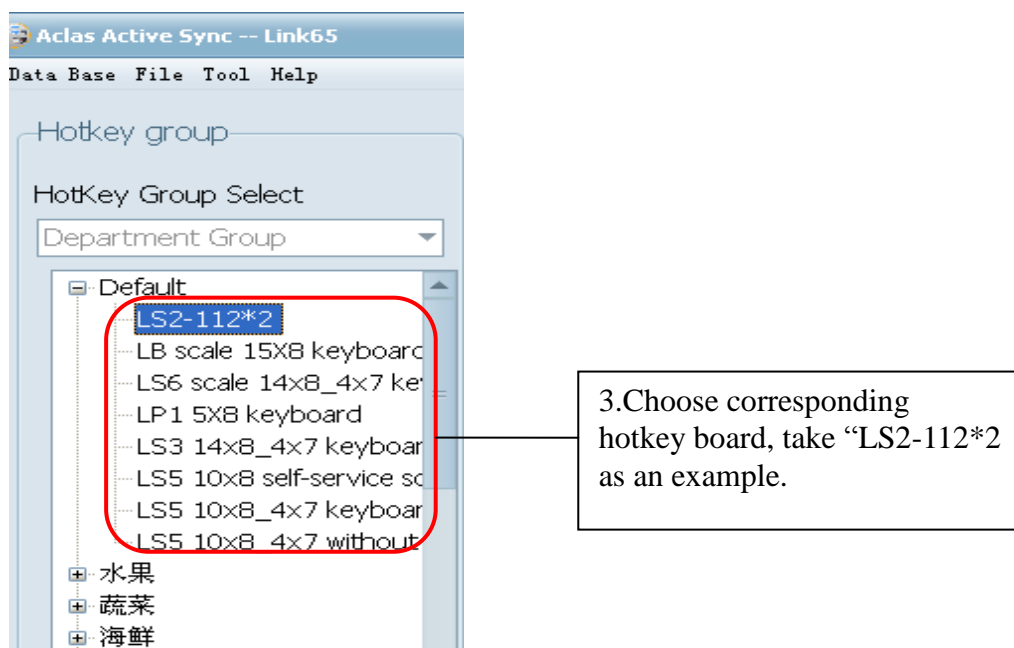
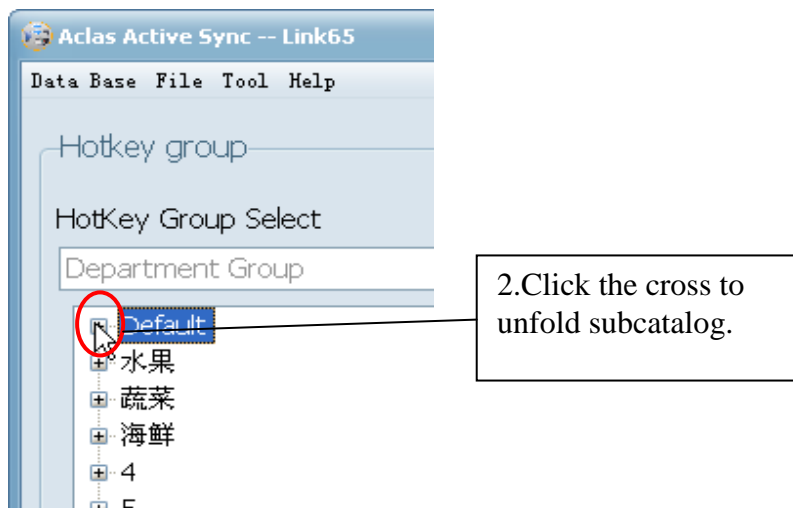
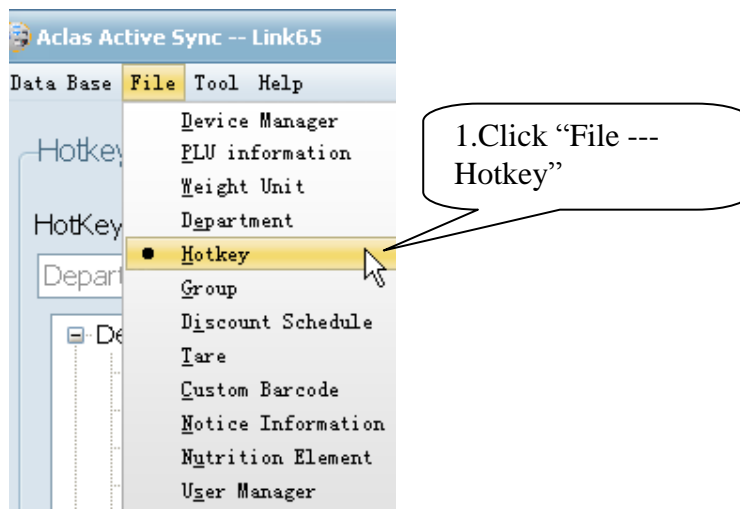



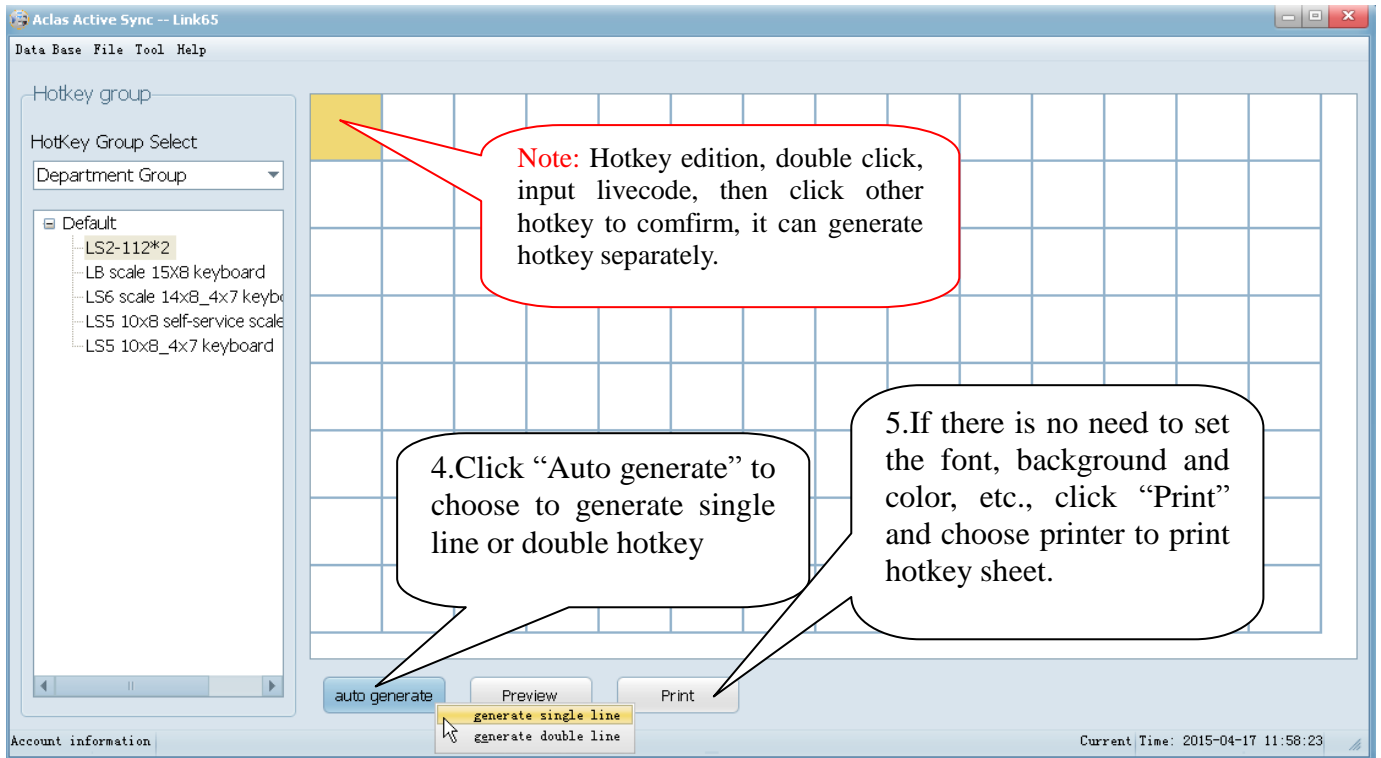

Right click “first line of key”(or second line of key”, key means both two lines are edited at the same time ) to select related items. Click font set to edit font, color and background of the hotkey, click function key to edit price, discount, tare, etc.

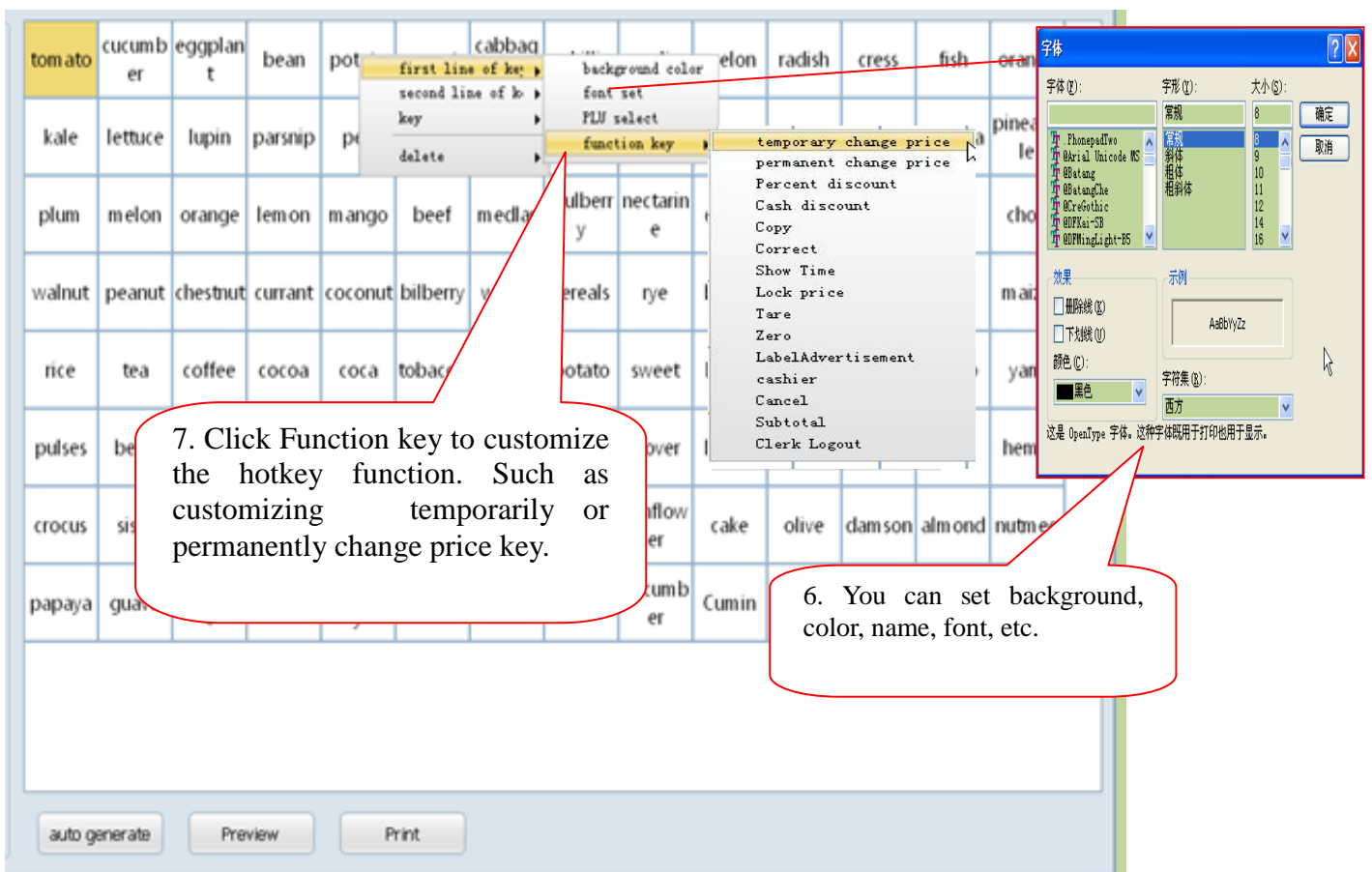

## 4.2 Hotkey Sheet Installation

**Note: Please refer to “PC software management/Hotkey” in attached CD.**

Cut the hotkey sheet down and insert the hotkey sheet into the keyboard. Please take below pictures for your references:

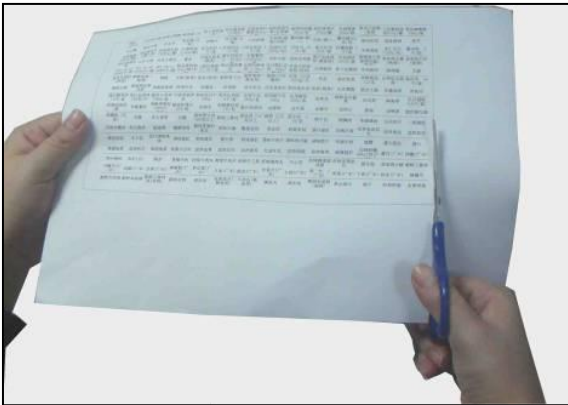

→ Cut the hotkey sheet down.

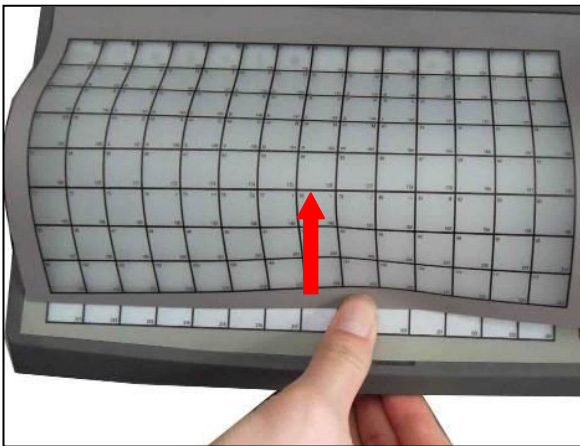
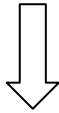

→ Push up the hotkey pad from bottom according to the arrow head.

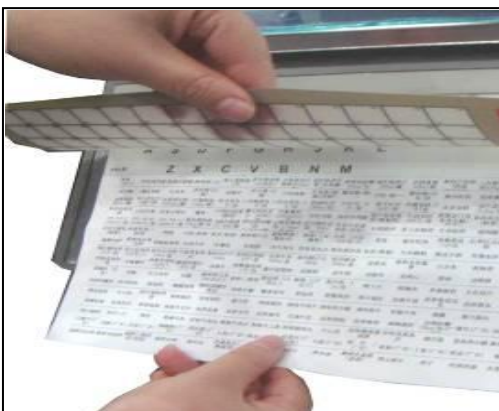
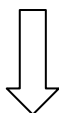

→ Insert the hotkey sheet into the hotkey pad.

# 5 Sales Operation

## 5.1 Calculate by Weight

There are three kinds of operation. If PLU data is downloaded by background server PC or pre-edited in the scale, operation follows method 1 or method 2. Otherwise the operation follows method 3.

### Notes:

- 1. AUTO state:** When power on, if “AUTO” signal is on, it means the scale is in “AUTO” print state. On the condition that the weight and the unit are nonzero and after the weight is steady, a label will be printed. Press “AUTO” key to switch off the state. Suggest making “AUTO” state as default state.
- 2. ZERO state:** Sometimes the display will not show “0.000” when there is not thing on the scale pan. Maybe the reason is that the scale loses balance. Beside adjusting the balance, during selling you can press “->0<-” to let weight return to zero level. It saves time and avoids weight mistakes.
- 3. Usage of Print key:** All of the following operations (including Calculate by Weight, Tare Operation, Calculate by Piece, Discount, and Change Price) are in the “Auto” print state. If the default print state is not in “Auto” state, the “AUTO” arrow on the LCD will disappear, you must press “Print” key in order to print the label.

### Method 1: Hotkey Operation

Trade example: Some onions weighing 2.000kg are sold. Its hotkey is 01, and price is 0.500\$/kg.

**Operation Steps:** Press “->0<-” key if the scale is not in “Zero” status → Put onions on the pan → Input the hotkey 01 of the onions through PLU keyboard → The label will print automatically (if the scale is not in auto print state, please press “Print” key to print the label).

### Note:

**There are 224 PLU hotkeys; the above operation is for the hotkeys from 1 to112. As to hotkeys from 113 to 224, the above operation step 3 “Input the hotkey 01 of the onions through PLU keyboard” should be changed as” Press “Shift” key and press the hotkey no. of the commodity”. Other steps are the same.**

### Method 2: General sales steps by inputting LFCODE.

Trade example: Some onions weighing 2.000kg are sold. Their LFCODE is 10, unit price is 1.500\$/kg.

**Operation Steps:** Press “->0<-” key if the scale is not in “Zero” status → Put onions on the pan → LFCODE 10 of the onions through small keyboard → The label will print automatically (if the scale is not in auto print state, please press “Print” key to print the label).

### Method 3: Operation for PLU without presettings.

**Before operation, please do as following:**

Press the “System Set” key for 3 seconds till a beep prompts out and press “Enter” key to confirm → Use “←” “→” to select “hardware set” → then use “←” “→” to choose item “label select (1~32)” → then please input label serial number that have edited and downloaded on label editor of PC.

**Operation Steps:** Press “->0<-” key if the scale is not in zero state → Press “SHIFT” & “Name Input”, and then input PLU name and press “Enter” to confirm → Input unit price 2.00 through the small keyboard → Put on the commodity weighing → Press key “Print”.

## 5.2 Calculate by Piece

There are two kinds of operation methods. Method 1 is for hot key sale and method 2 is suitable for sale by LFCODE.

**Note: Set the price unit into PCS/kg in the PC software before taking the following operations.**

### Method 1: Hotkey operation step

Trade example: Ten pieces of cake are sold. The hotkey of cake is 05. The unit is PCS/kg.

**Operation Steps:** Input the number cake through small keyboard (take 10 pieces as example) → Press “Qty” key → Press the corresponding hotkey 05 of the cake through PLU keyboard → The label will print automatically (if the scale is not in auto print state, please press “Print” key to print the label).

### Method 2: General Operation Steps

Trade example: Ten pieces of cakes are sold and the LFCODE of the cake is 12. The unit is PCS/kg

**Operation Steps:** Input the number cake through small keyboard (take 10 pieces as example) → Press “Qty” key → Input LFCODE of the cake 12 through small keyboard. → Press “PLU” key → The label will print automatically (if the scale is not in auto print state, please press “Print” key to print the label).

## 5.3 Tare Operation

It is only suitable for the commodity packed in package or container such as eggs, beans or fruit and so on.

### Method 1: Operation for commodity separated from container or package.

Trade example: A package of apples is sold. The hotkey of apples is 05, the net weight is 2.000kg and unit price is 6.000\$/kg.

**Operation Steps:** Put the container or package weighing 1.000 kg on the pan → Press “->T<-” key → Put one contain of apples weighing 2.000kg on the pan → Key in the hotkey 05 of apple through PLU keyboard → Take away the container and the apples on the tray, then press “->T<-” key to cancel the weight-deducting state.

### Method 2: Operation for commodity that its tare weight is known but could not separated from container or package.

Trade example: A package of apples is sold. The unit price is 6.000\$/kg, the tare weight is 1.000kg. The weight of apple and package is 2.000kg.

**Operation Steps:** Press “->0<-” key if the scale is not in zero state → Input the tare weight through small keyboard → Press “->T<-” key → Put a package of apples on the pan → Input the hotkey 05 of apple through PLU keyboard → Take away the container and the apples on the tray, then press “->T<-” key to cancel the weight-deducting state.

### Method 3: Operation for commodity that its tare weight is known and has been set in software but could not separated from container or package.

Trade example: A package of apples is sold. The unit price is 6.000\$/kg, the tare weight is 1.000kg. The preset number of tare weight is 1. The weight of apple and package is 2.000kg.

**Operation Steps:** Press “->0<-” key if the scale is not in zero state → Press key “1” from the small keyboard, and then press “SHIFT” key and “->T<-” → Put a page of apples on the pan → Key in the hotkey 05 of apple through PLU keyboard → Take away the container and the apples on the tray, then press “->T<-” key to cancel the weight-deducting state.

## 5.4 Discount

The scale supports two kinds of discount: discount % and total discount. This function can be locked by password which is set and can be randomly changed by background sever PC.

- **% Discount**

Trade example: some peaches give a discount of 95. Its unit is 8.0\$/kg and hotkey is 12.

**Operation Steps:** Input discount proportion of the commodity “95” through numeric keyboard → Press “%Discount” key → Put peaches weighing 1.000kg on the pan → Key in the corresponding hotkey of the peaches e.g. 12 → The label will print automatically (if the scale is not in auto print state, please press “Print” key to print the label).

- **Total discount**

Press key “SHIFT” & “Total Discount” → Input the discount amount 1\$, and then press key “ENTER” → Put the commodity weighing 1.000kg on the pan → Key in the corresponding hotkey of the peaches e.g. 12.

## 5.5 Name Input Function

This function is used to sell the commodity temporary.

Step 1: Press [SHIFT] key, and then press [Name Input] key.

Step 2: Input the PLU name according to the display screen indicating.

Step 3: Press ‘enter’ key to confirm (Please take reference to calculate by weight: method 3)

## 5.6 Change Price

There are two methods to change the unit price of a commodity, they are permanently change price and temporarily change price.

Permanently change price: long press “Price Update” key 1.5s.

Temporarily change price: short press “Price” key.

Change price via hotkey: hotkey → Price → new unit price → Enter → Put on commodity

Change price via LFCODE: Price → LFCODE → new unit price → Enter → Put on commodity

## 6 Package Type

### 6.1 Package by Fixed Weight

The function of fix weight package is available by setting on PC software first. The setting method can be seen in PC Management chapter Package by Fixed Weight.

For example: pack apple by the fixed weight 0.356kg, 10 ¥ per kilogram, and the corresponding hotkey is 38.

Operation Steps: Open PC management PLU manager, select “Package by fixed weight” from package type column, input 356g into package weight column and input “10%” into the error bar. Please click “Synchronous Data” to upload data into the scale.

**Note: Before operate on the scale, please press key “Price Lock” first, and the indicator light for ‘price lock’ will be on.**

Operation Steps: Put the apple on the pan → Press the hotkey 38 of the fish via PLU keyboard.

**Note: now the weight displays on the scale is the weight of the commodity, unit price displays on the scale is the fixed weight preset on PC, the total price displays on the scale is equal to fixed weight times the commodity weight. In Fixed Weight package mode, the commodity cannot be sold at the condition that its weight is beyond the preset error value  $\pm 10\%$ g (if the weight of the commodity is less than 0.3382 or beyond 0.378, the commodity cannot be sold and the label cannot be printed.).**

### 6.2 Package by Fixed Price

Fix price package, this function is available by setting on PC software first. Select the package mode as “Fixed weight”.

For example, sale apple by the fixed weight 0.356kg for 10 RMB in fixed price weight, and the hotkey is 38.

Operation Steps: Open PC management PLU manager, select “Package by fixed price” from package type column, input 356g into package weight column and input “10%” into the error bar.

Operation Steps: Put the apple on the pan → Press the hotkey 38 of the fish via PLU keyboard.

**Note: Now the weight displays on the scale is the weight of the commodity, unit price displays on the scale is the fixed weight preset on PC, the total price displays on the scale is equal to the unit price of the commodity. In Fixed Price package mode, the commodity cannot be sold at the condition that its weight is beyond the preset error value  $\pm 10\%$ g (if the weight of the commodity is less than 0.3382 or beyond 0.378, the commodity cannot be sold and the label cannot be printed.).**

### 6.3 Gift Baskets Function

Gift basket function is usually used in the aspect like pack gift-box and fruit-dish. Firstly set a hotkey 1 as ‘gift baskets’ on the PC software first.

1. Open PC management PLU manager, set live code of gift basket as 950002:

Input “gift basket” into name column; set price as “0”; select “package by fixed price and weight”; set tare weight ad 0.000.

Note: When use gift baskets, input “0” or “1” into “tare weight” to choose label print way. “1” means print one label separately for each commodity of the gift basket under weighing process and then print one summary label; “0” means only print one summary label (will not print label alone when weighing commodities).

For example: Package a fruit-dish (apple, grape, and orange)

PLU name: apple	weight unit: kg	unit price: 10.00 \$/kg	hotkey 06
PLU name: orange	weight unit: kg	unit price: 4.00 \$/kg	hotkey 07
PLU name: grape	weight unit: kg	unit price: 20.00 \$/kg	hotkey 08

Suppose each of the three fruits is 1.000kg, and the live code of gift basket is 950002.

Operation Steps: Press hotkey 1 → input live code 950002 → put apple on the scale pan, press hotkey 06 → put orange on the scale pan, press hotkey 07 → put grape on the scale pan, press hotkey 08 (→ if you need to set the price of gift basket, like 2\$, then input “200” ) → press hotkey 1 again.

## 7 Basic settings

Scale IP Settings: “System Set” → “Enter” → “N (Network Set)” on Mylar → I → B

Print Density Settings: “System Set” → “Enter” → H → D

Paper Type Settings: “System Set” → “Enter” → H → S

Total Price Format: “System Set” → “Enter” → J

Alignment Value: “System Set” → “Enter” → H → A

Date Settings: “System Set” → “Enter” → H → T

**Note: those capital letters above are in the machine Mylar.**



## 8 Appendix: Barcode Coding List

Barcode type	Department	Commodity number	Total price	Weight	Checksum
00~09: Ean13 code, the front two codes represent department code:					
00	DD (2)	IIIIIIII (10)	X	X	C
01	DD (2)	IIIII (6)	PPPP (4)	X	C
02	DD (2)	IIIII (5)	PPPPP (5)	X	C
03	DD (2)	IIII (4)	PPPPPP (6)	X	C
04	DD (2)	III (3)	PPPPPPP (7)	X	C
05	DD (2)	IIIII (6)	X	Q.QQQ (4)	C
06	DD (2)	IIIII (6)	X	QQ.QQ (4)	C
07	DD (2)	IIIII (5)	X	QQ.QQQ (5)	C
08	DD (2)	IIII (5)	X	QQQQ.Q (5)	C
09	DD (2)	IIII (5)	X	QQQQQ (5)	C
10~19: Ean13code, the front two codes represent fixed code:					
10	20(2)	IIIIIIII (10)	X	X	C
11	21(2)	IIIII (6)	PPPP (4)	X	C
12	22(2)	IIIII (5)	PPPPP (5)	X	C
13	23(2)	IIII (4)	PPPPPP (6)	X	C
14	24(2)	III (3)	PPPPPPP (7)	X	C
15	25(2)	IIIII (6)	X	Q.QQQ (4)	C
16	26(2)	IIIII (6)	X	QQ.QQ (4)	C
17	27(2)	IIIII (5)	X	QQ.QQQ (5)	C
18	28(2)	IIII (5)	X	QQQQ.Q (5)	C
19	29(2)	IIII (5)	X	QQQQQ (5)	C
20: no print barcode					
21~29: Ean13 code, the front one code represents department code:					
21	D (1)	IIIIII (7)	PPPP (4)	X	C
22	D (1)	IIIII (6)	PPPPP (5)	X	C
23	D (1)	IIII (5)	PPPPPP (6)	X	C
24	D (1)	IIII (4)	PPPPPPP (7)	X	C
25	D (1)	IIIIII (7)	X	Q.QQQ (4)	C
26	D (1)	IIIIII (7)	X	QQ.QQ (4)	C
27	D (1)	IIIII (6)	X	QQ.QQQ (5)	C
28	D (1)	IIIII (6)	X	QQQQ.Q (5)	C
29	D (1)	IIIII (6)	X	QQQQQ (5)	C
30~35,40~45: 18code, the front one code represents department code					
30&33	D (1)	IIIII (6)	PPPPP (5)	QQ.QQQ (5)	C
31&34	D (1)	IIIII (6)	PPPPP (5)	QQQQ.Q (5)	C
32&35	D (1)	IIIII (6)	PPPPP (5)	QQQQQ (5)	C
Barcode type	Department	Commodity number	Price	Weight	Checksum
40~45: Ean18 code, the front one code represents department code					
40&43	D(1)	IIIII(6)	UUUUU(5)	WW. WWW(5)	C
41&44	D(1)	IIIII(6)	UUUUU (5)	WWWW.W(5)	C
42&45	D(1)	IIIII(6)	UUUUU (5)	WWWWW(5)	C
50~52: 8 code					
50	X	IIIIII (7)	X	X	C
51	D (1)	IIIII (6)	X	X	C
52	DD (2)	IIII (5)	X	X	C

53	X	IIIIII(8)	X	X	X
54	D(1)	IIIIII(7)	X	X	X
55	DD(2)	IIIIII(6)	X	X	X
36-38: 18code, the front one code represents department code, which is particular for the batch management of live commodity.					
36	D (1)	LLLLLL (6)	III (4)	RR (2)	QQ.QQQ (5)
37	D (1)	LLLLLL (6)	III (4)	RR (2)	QQQQ.Q (5)
38	D (1)	LLLLLL (6)	III (4)	RR (2)	QQQQQ (5)

Bar code type	Department	Art. No	Quantity/weight	Total/Unit price	Check sum
79~85, 87: 18 code					
79	DD	IIIII(6)	WW.WWW	PPPPP	X
80	D	IIIII(6)	WW.WWW	PPPPP	C
81	D	IIIII(6)	WWWW.W	PPPPP	C
82	D	IIIII(6)	WWWWW	PPPPP	C
83	D	IIIII(6)	WW.WWW	UUU.UU	C
84	D	IIIII(6)	WWWW.W	UUU.UU	C
85	D	IIIII(6)	WWWWW	UUU.UU	C
87	DD	IIII(5)	WW.WWW	PPPPP	C

Bar code type	Department	Art. No	Total price	Quantity/weight	Unit price	Check sum
90~95: 18 code, the former two codes print department code						
90	DD(2)	IIIII(6)		WW.WWW	UU.UU(4)	C
91	DD(2)	IIIII(6)		WWWW.W	UU.UU(4)	C
92	DD(2)	IIIII(6)		WWWWW	UU.UU(4)	C
93	D(1)	IIIII(6)	PPPPP(5)		UUU.UU(5)	C
94	DD(2)	IIII(5)	PPPPP(5)	WW.WWW		C
95	DD(2)	IIIII(6)		WWWWW	UU.UU(4)	C
Bar code type	Department	Art. No	Quantity/weight	Total price	Unit price	Check sum
96	DD(2)	IIIII(6)	WWWW	PPPPP(5)		C
Bar code type	Department	Art. No	Total price	Quantity/weight	Unit price	Check sum
97	DD(2)	IIII(4)	PPPPP(6)	WW.WWW		C
Bar code type	Department	Art. No	Quantity/weight	Total price	Unit price	Check sum
98	DD(2)	IIII(5)	UUUUU(5)	WW.WWW		C

Meaning of characters in the above list:

C: CHECKSUM D: Department code 2: Fixed number I: commodity number L: Live code  
P: price R: discount Q: weight X: no this item

Notes:

- Ean 13= DEPARTMENT+CODE+[TOTAL PRICE]+[WEIGHT]+C  
Items with [] mean no this item in some coding system.
- Usually Ean13 adopts 2 or 22 as its price barcode type while 7 or 77 as its weight barcode type.
- CHECKSUM is calculated by the scale automatically and it is not necessary for user to input in PLU manager.
- The difference between 30-32 and 33-35 is the method to calculate checksum.
- The difference between 40-45 and 30-35 is that the price in 30-35 is total price while in 40-45 is unit price.
- 36-38 is barcode type, which can be accessed by live batch management. Commodity batch number takes up commodity number column and commodity number takes up live code column.







