

Thermal Barcode Printer

User Manual

THERMAL BARCODE PRINTER

PROFICIENT IN COMMERCIAL POS BARCODE PRINTERS

- Please keep the user's manual in reference

User Manual

- 1. Introduction.....2**
 - 1.1 Safety Warning2
 - 1.2 Note2
- 2. General Information3**
 - 2.1 Introduction3
 - 2.2 Main Features3
- 3. Printer Parts3**
- 4. Paper Roll Installation5**
- 5. Specification8**
 - 5.1 Specification Table9
- 6. Setting Up the Printer10**
 - 6.1 Unpacking10
 - 6.2 Power Cable Connection10
 - 6.3 Data Cable Connection10
 - 6.4 Media Installation10
- 7. Power On Utilities10**
 - 7.1 Self-Test10
 - 7.2 Gap Sensor Calibration11
 - 7.3 Hexadecimal Dumping12
 - 7.4 Skip AUTO.BAS12
 - 7.5 Printer Initialization13
- 8. Indicators and Buttons.....13**
 - 8.1 Indicators13
 - 8.2 Buttons13
- 9. Maintenance14**
 - 9.1 Printer Cleaning14

1 、 Introduction

Thanks for choosing our thermal label printer. This product provides reliable performance and high printing quality at economic price. With powerful functions and easy operation design, thermal label printer is your best choice of thermal label printer.

CAUTION, NOTE

 **CAUTION:** MUST COMPLY, OTHERWISE HUMAN GET HARM AND DEVICES DAMAGE.

 **NOTE:** IMPORTANT INFORMATION AND TIPS FOR PRINTERS OPERATION.

SAFETY WARNING

PLEASE READ THE BELOW WARNINGS AND NOTES CAREFULLY BEFORE USING THE PRINTER.

1.1 SAFETY WARNING

 **CAUTION:** THE PRINT HEAD IS A HEATED PART, PLEASE DO NOT TOUCH THE PRINT HEAD AND OTHER PARTS AROUND IT IN AND AFTER THE PRINTING PROCESS.

 **CAUTION:** DO NOT TOUCH THE PRINT HEAD AND PLUG-IN PARTS TO AVOID PRINT HEAD DAMAGE.

 **CAUTION:** DO NOT TOUCH THE PAPER TEAR-OFF KNIFE TO AVOID GETTING HARM.

1.2. Safety Notice:

- * Don't touch the printer head with anything.
- * Don't touch the cutter blade.
- * Don't bend the power cord excessively or place any heavy objects onto it.
- * Don't use the printer when it is out of order. This can cause a fire or an electrocution.
- * When connecting or disconnecting the plug, always hold the plug but not the cord.
- * Keep the desiccant out of children's reach.
- * Use only approved accessories and do not try to disassemble, repair or remodel it by yourself.
- * Install the printer on the stable surface. Choose firm, level surface where avoid vibration.
- * Don't let water or other foreign objects into the printer.
- * Don't connect a telephone line into the peripheral drive connector.
- * We recommend that you unplug the printer from the power outlet if no use it for a long period .

2 、 General Information

2.1 Introduction

Thermal label printer is designed for real-time and batch label printing, which is applicable in the field of transportation, logistics, post, retail sale, and etc. The printer can be connected with other equipment with various interface cards, such as Parallel, Serial, USB and LAN. It supports different paper media, including thermal paper roll, thermal label paper and sticker paper.

The printer provides direct thermal printing at selectable printing speed of 2.0, 3.0, 4.0 and 5.0 inches per second. It accepts roll feed, die-cut and fan-fold labels. All common bar code formats are available. Font and bar codes can be printed in 4 directions and in 1 to 10 times enlargement size. High performance and efficiency of label printing save your time!

2.2 Main Features

- Support thermal paper roll, thermal label paper and sticker paper.
- Support printing media width from 16mm to 82mm.
- Auto paper adjusting function.
- Auto temperature control for durable printing.
- Module design for different application.

3 、 Printer Parts

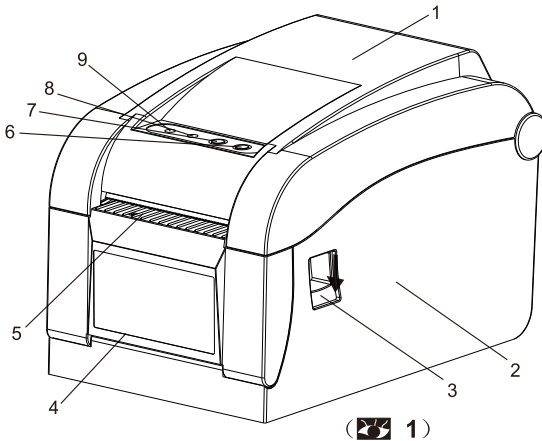

- 1- Top Cover 2- Base housing 3- Top Cover Open Button
4- Backing Paper Opening 5- Label Opening 6- Feed Button
7- Pause Button 8- Error Indicator 9- ONLINE/POWER Indicator

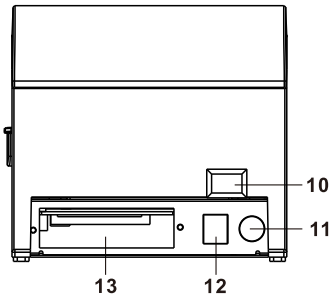

(2)

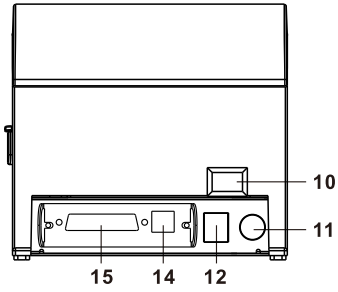

(3)

- 10- Power Switch 11- Power Jack 12- Cashdrawer Jack
 13- Parallel Interface 14- USB Interface 15- Serial Interface

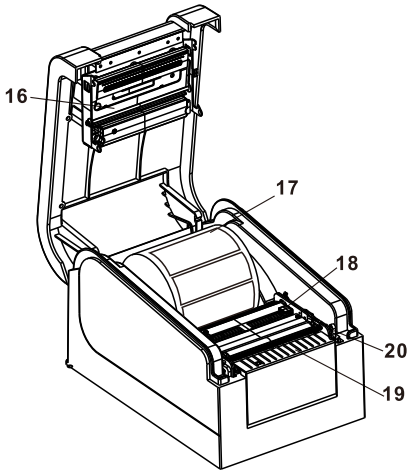

(4)

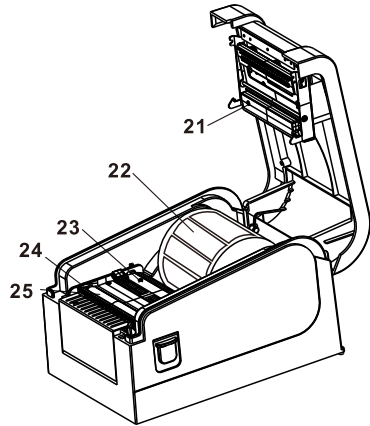

(5)

- 16- Print Head 17- Paper Roll 18- Label Guide 19- Paper Presence Sensor
 20- Peel-off Roller Lever 21- Light Transmission Sensor Light Source
 22- Paper Roll Spindle 23- Light Transmission Sensor Receiver
 24- Peel-off Spindle 25- Peel-off Roller

4. Paper Roll Installation

(1) Insert the paper roll spindle into a paper roll, and place the paper roll into the printer. Fixing tab on the paper roll spindle should be inside the internal paper roll mount. Adjust the paper roll spindle position with the paper roll mount.

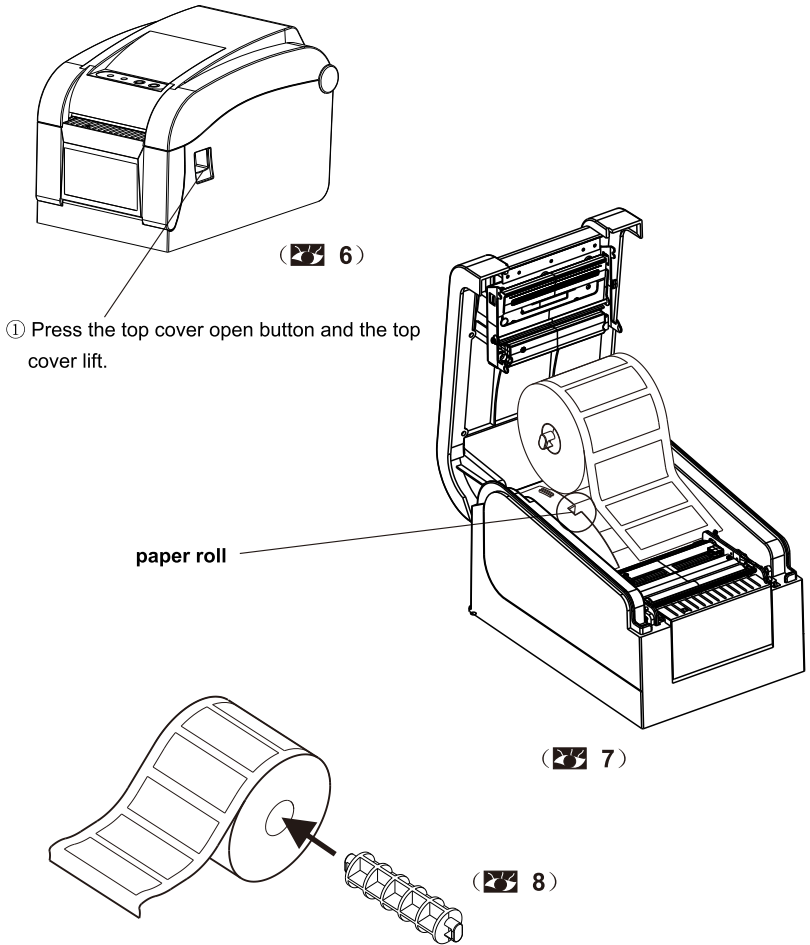

① Press the top cover open button and the top cover lift.

② Insert the paper roll spindle into the paper roll, and adjust the spindle position to make it in the center of the paper roll.

- ③ Place the paper roll into the internal paper roll mount. Please make sure the paper printing side face up as shown in the below photo.

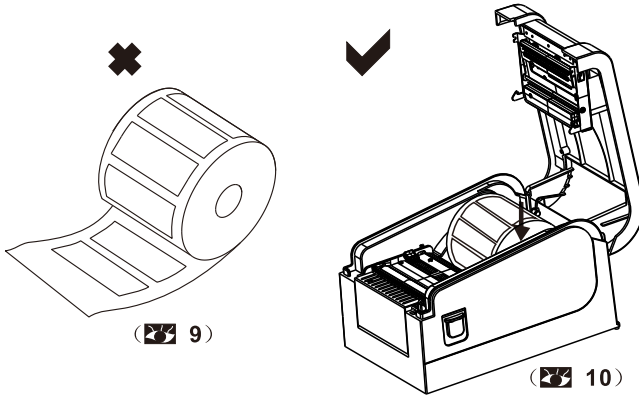

(2) Loading label for peel-off mode

- ① Thread the label through the label guides and move the label guides to adjust the fitness paper width. In addition to the outer label paper roll, can be passed through the gap at the back side of printer.

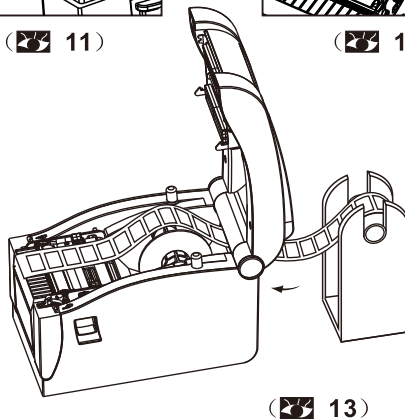
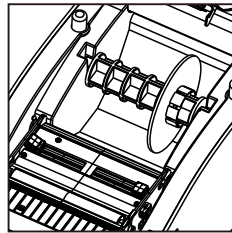
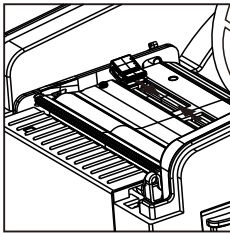

② Pull down the peel-off roller lever to unlock the peel-off roller.

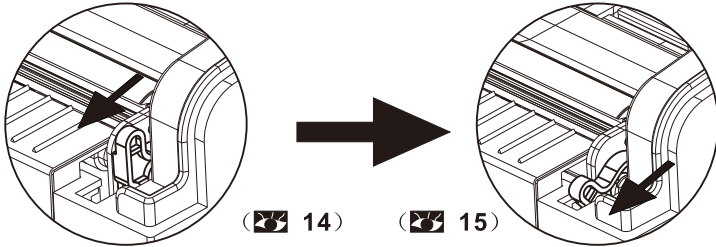

Lever stands, the peel-off roller is locked.

Lever down, the peel-off roller is unlocked.

③ Split the label paper and backing paper manually and keep the label paper in the label opening. Thread the backing paper in front of the peel-off spindle and into the peel-off part.

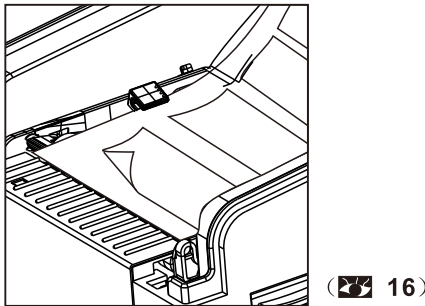

④ Pull up the peel-off lever and the peel-off roller presses on the backing paper. Close the top cover.

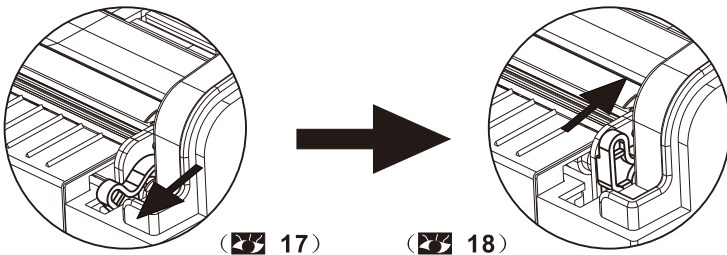

Lever down, the peel-off roller is unlocked.

Lever stands, the peel-off roller is locked, and the backing paper is in the peel-off part.

⚠ Note:

If the peel-off function fails, please check:

1. The printing media is installed correctly.
2. The backing paper must be in front of the peel-off spindle.
3. The peel-off roller needs to press on the backing paper.
4. The peel-off roller lever must stand.

Please refer the pictures below:

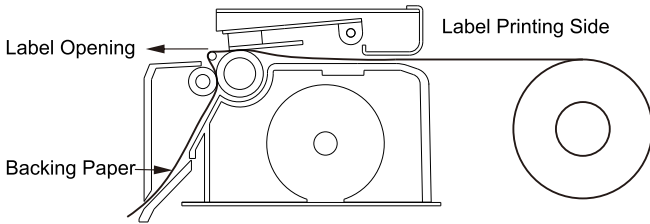

(19)

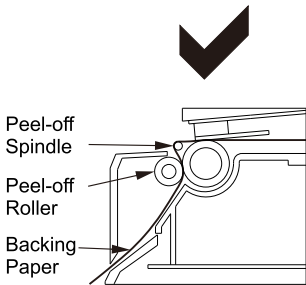

(20)

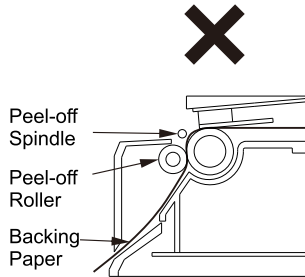

(21)

5. Specification

5.1 Specification Table

SPECIFICATIONS

		Parameter
Print	Printing method	Direct Thermal
	Resolution	203DPI
	Print width	16-82mm
	Print speed	152mm/s
	Memory	DRAM:4M FLASH:4M
	Print head temperature sensor	Thermal Sensitive Resistance
	Print head position sensor	Microswitch
	Paper detection sensor	Photoelectricity sensor
Interface	RS-232+USB+LAN/USB	
Bar code Font Graphics	Bar code	CODE128, EAN128, ITF, CODE39, CODE93, EAN13, EAN13+2, EAN13+5, EAN8, EAN8+2, EAN8+5, CODABAR, POSTNET, UPC-A, UPCA+2, UPCA+5, UPC-E, UPCE+2, UPC-E+5, CPOST, MSI, MSIC, PLESSEY, ITF14, EAN14
	QR code	QRCODE、PDF、Data Matrix
	Internal font	FONT 0 to FONT 8 ,TST24.BF2, TSS24.BF2,K
	Enlargement & rotation	1 to 10 times enlargement in both directions 0° , 90° , 180° , 270° ,360° rotation
	Graphics	Mono PCX and BMP files can be downloaded into FLASH and DRAM
Media	Media type	Thermal paper rolls, self-adhesive paper, etc
	Media width	16mm - 82mm
	Media diameter	Max. 80mm, Or outer label paper roll
	Media core diameter	Min. 25mm
	Paper off mode	Tear off and Peel off
Power	Input	24VDC, 2.5A
Environment condition	Work	5 ~ 45°C, 20 ~ 80%RH
	Storage	- 40 ~ 55°C, ≤93%RH (40°C)
Physical dimension	Diameter	220(D)×148(W)×150(H)mm
	Weight	≈1.5kg

The printer supports both continuous and non-continuous paper.

- Continuous type: Paper roll
- Non-continuous type: 1) Label roll; 2) Sticker paper.

6 . Setting Up the Printer

6.1 Unpacking

Please unpack the printer package, and inspect the parts according to the packing list. If any parts are missing or damaged, please contact the customer service of your purchased reseller or distributor.

6.2 Power Cable Connection

( 22)



24V DC

- 1) Make sure the printer power switch is OFF;
- 2) The printer power jack is a 3-pin socket and for 24V DC power input. Please plug the DC cord connector into the printer's power jack properly.

CAUTION:

- When connecting or disconnecting the plug, always hold the plug but not the cord.
- Avoid pulling the power cord, otherwise any damages may cause a fire or electrocution.
- Avoid placing the power cord around other over heated equipment to prevent power cord melting, which may cause a fire or electrocution.
- We recommend that you unplug the printer from the power outlet if no use it for a long period

6.3 Data Cable Connection

- 1) Make sure the printer power switch is OFF.
- 2) Plug the data cable connector into the printer's interface properly.
- 3) Plug the other end of the data cable with the host computer.

CAUTION:

- Please do not plug the data cable when the printer power is ON.

6.4 Media Installation

To install the sticker paper and label roll, please refer "4. Paper Roll Installation".

7、 Power On Utilities

There are five power-on utilities to set up and test printer hardware. These utilities are activated by pressing FEED button and PAUSE button.

7.1、 Self-Test

To start the printer self-test, please follow the below steps,

1. Turn off the printer power.
2. Make sure the paper roll is installed correctly and the printer top cover is closed.
3. Press the FEED button and turning on the printer power simultaneously. When the self-test paper (chart 21) comes out, release the FEED button.

Self-test Page Sample:

SELFTEST.....Self-test Mode

SELFTEST



(23)

```

VERSION : V2.0HT (2015-08-08) ..... Firmware version
INTERFACE: USB & ..... USB communication parameters
          SERIAL 9600, N, 8, 1 & ..... Serial communication parameters
          Ethernet(10M/100M) ..... Lan communication parameters
PROTOCOLS: TCP/IP
IP ADDR : 192.168.123.100
MAC ADDR : 00-2C-60-64-69-6A
NETMASK : 255.255.255.0
GATE WAY : 192.168.123.1
NET DHCP : Disabled ..... Obtain ethernet information automatically
DHCP TIME: 90
SPEED : 5 ..... Print speed
DENSITY : 7 ..... Print darkness
SIZE : 76 mm , 40 mm ..... Paper width
GAP : 2 mm , 0 mm ..... Gap distance
CODE PAGE: 437 ..... Code page
MILAGE(m) : 27.575500 m ..... Printed mileage (meter)
REFERENCE: 0 mm , 0 mm ..... Reference offset
DIRECTION: 0, 0 ..... Print direction
SHIFT : 0 ..... Label print offset
OFFSET : 0 ..... Paper tear-off offset functions
SET PEEL : OFF ..... Peel-off mode
SET TEAR : ON ..... Tear-on mode
SET HEAD : ON ..... Cover opening sensor
SET PRINTKEY : OFF ..... Press & print function
SET REPRINT : OFF ..... Auto reprint function
SET KEY1(FEED) : ON ..... Feed button function
SET KEY2(PAUSE) : ON ..... Pause button function
TAIWANESE BIG5 : TST24.BF2 ..... Taiwanese
CHINESE GB18030 : TSS24.BF2 ..... Chinese
KOREAN KSC5601 : K ..... Korean
BARCODE 2D : QRCODE,DataMatrix,PDF417
USB NUMBER FIX : NO ..... USB port fixed mode
    
```

} button function

```

SERCTOR ZIZE : 4 KBYTES
PHYSICA DRAM : 4096 KBYTES
AVAILABLE DRAM : 2048 KBYTES FREE
PHYSICAL FLASH: 4096 KBYTES
AVAILABLE FLASH: 2048 KBYTES FREE
DRAM FILE : 0 FILE(S)
FLASH FILE : 0 FILE(S)
    
```

} Numbers of download files
Physical & available
memory space



7.2 Gap Sensor Calibration

Gap sensor sensitivity should be calibrated at the following conditions

1. A brand new printer
2. Label stock changed
3. Printer initialization

This function is to reset the label gap sensor sensitivity when the printer power is turned on. User needs to start the calibration of the gap sensor sensitivity after loading a different type of label roll or the printer is initialized.

Please follow the steps below to calibrate the gap sensor:

1. Turn off the printer power.
2. Make sure the label roll is installed correctly and the printer top cover is closed.
3. Press and hold on the PAUSE button, then turn on the printer power. The printer will automatically calibrate the gap sensor sensitivity and save the gap length into DRAM. After then release the PAUSE button.

7.3 Dump mode

Please follow the steps below:

1. Turn off the printer power.
2. Make sure the label roll is installed correctly and the printer top cover is closed.
3. Press and hold on the PAUSE button and FEED button, then turn on the printer power. When the POWER indicator (blue light) and ERROR indicator (red light) light simultaneously, release both buttons. The printer is changed to Dump Mode and print as below chart.

```

*****
* NOW IN DUMP MODE *
*****

SELFTE 0A 53 45 4C 46 54 45
ST      53 54 0D 0A
  
```

 24

Note: Printer will not print if data is not more than one piece of label, and need to press FEED button to force the printer to print it out.

7.4 Skip AUTO.BAS

User can download an auto execution file (AUTO.BAS) to flash memory. Printer will run the AUTO.BAS program immediately when turning on printer power. The AUTO.BAS program can be interrupted by the power-on utility.

Please follow the steps below to skip the AUTO.BAS:

1. Turn off the printer power.
2. Press and hold on the PAUSE button and FEED button, then turn on the printer power. When the POWER indicator (blue light) dims and ERROR indicator (red light) lights, release both buttons. The printer skips running the AUTO.BAS program. And then the POWER indicator lights.

7.5 Printer Initialization

Printer initialization is used to clear DRAM and restore printer settings to defaults. Please do the gap sensor sensitivity calibration after the printer initialization.

Please follow the steps below to initialize the printer:

1. Turn off the printer power.
2. Press and hold on the PAUSE button and FEED button, then turn on the printer power. When the POWER indicator (blue light) lights and ERROR indicator (red light) dims, release both buttons. The printer DRAM is cleared and printer settings are restored to defaults.

8. Indicators and Buttons

The printer has two indicators (POWER indicator in blue light and ERROR indicator in red light) and two buttons (PAUSE and FEED).

8.1 Indicators:

Item	Indicators Status	Descriptions
1	POWER indicator is ON ERROR indicator is OFF	Printer is powered on and in normal print mode.
2	POWER indicator flashes slowly (640ms) ERROR indicator is OFF	Printer is paused.
3	POWER indicator flashes fast (160ms) ERROR indicator is OFF	Printed label is peel-off but not taken off.
4	POWER indicator is OFF ERROR indicator flashes fast (160ms)	Printer cover is opened.
5	POWER indicator is OFF ERROR indicator flashes slowly (640ms)	Paper shortage or gap sensor calibrated error.
6	POWER indicator flashes fast (160ms) ERROR indicator flashes fast (160ms)	Printer overheated protection is activated. After 1 minute, the printer will check again the temperature of print head. If the temperature gets right, printer resumes working.

8.2 Buttons

Item	Functions	Descriptions
1	Feed	Press the FEED button when POWER indicator is on and ERROR indicator is off. It feeds the label to the beginning of the next label
2	Pause	Press the feed button during printing and the printing job is suspended.
3	Self-test	<ol style="list-style-type: none"> 1. Turn off the printer power. 2. Make sure the paper roll is installed correctly and the printer top cover is closed. 3. Press the FEED button and turning on the printer power simultaneously. When the self-test paper comes out, release the FEED button.

4	Gap sensor calibration	<ol style="list-style-type: none"> 1. Turn off the printer power. 2. Make sure the label roll is installed correctly and the printer top cover is closed. 3. Press and hold on the PAUSE button, then turn on the printer power. The printer will automatically calibrate the gap sensor sensitivity and save the gap length into DRAM. After then release the PAUSE button.
5	Dump mode	<ol style="list-style-type: none"> 1. Turn off the printer power. 2. Make sure the label roll is installed correctly and the printer top cover is closed. 3. Press and hold on the PAUSE button and FEED button, then turn on the printer power. When the POWER indicator (blue light) and ERROR indicator (red light) light simultaneously, release both buttons. The printer is changed to Dump Mode.

9. Maintenance

9.1 Printer Cleaning

To ensure the printing quality, please proceed this maintenance section to keep your printer in good conditions and extend its life.

Please use one of following material to clean the printer:

- Cotton swab
- Lint-free cloth
- Vacuum / Blower brush
- 100% ethanol

The cleaning process is described as following

Printer Part	Method
Print Head	<ol style="list-style-type: none"> 1. Turn off the printer power before cleaning the print head. 2. Allow the print head to cool for at least one minute. 3. Use a cotton swab and 100% ethanol to clean the print head surface.
Platen Roller	<ol style="list-style-type: none"> 1. Turn off the printer power. 2. Rotate the platen roller and use a cotton swab or lint-free cloth to wipe it thoroughly with 100% ethanol.
Exterior	Wipe it with water-dampened cloth.
Interior	Use a vacuum or blower brush to clean the dust.

Note:

- Always turn off the printer power before cleaning the printer.
- Do not touch print head by hand. Tweezers is not allowed to use for cleaning, otherwise the print head, platen roller or sensor may be damaged.
- Please use 100% ethanol. DO NOT use medical alcohol, gasoline or acetone, which may damage the print head and platen roller.
- Do the sensor calibration after cleaning the sensors.
- Only turn on the printer and resume printing job after the ethanol volatilized.

 WARNING:

All rights reserved. No part of this publication may be reproduced, stored in a retrieval, or transmitted in any form or by any means, electronic, mechanical, photocopying, recording, or otherwise. The company reserves the rights of modifications of manufacture technology, assembly, software and hardware without notice.